

Grazing Incidence Optics Technology

Project Manager(s)/Lead(s)

Brian Ramsey/ZP12—Project Scientist
(256) 961-7784

W. Scott Smith/ES31—Technical Lead
(256) 544-5175

Mikhail Gubarev/ZP12
(256) 961-7852

Jeff McCracken/ZP20—Manager
(256) 961-7457

Sponsoring Program(s)

Marshall Space Flight Center/Center Management and Operations
Center Strategic Development Steering Group—
Internal Technology Development Funds

Project Description

This project is to demonstrate the capability to directly fabricate lightweight, high-resolution, grazing-incidence x-ray optics using a commercially available robotic polishing machine.

Typical x-ray optics production at NASA Marshall Space Flight Center (MSFC) uses a replication process in which metal mirrors are electroformed on to figured and polished mandrels from which they are later removed. The attraction of this process is that multiple copies can be made from a single master. The drawback is that the replication process limits the angular resolution that can be attained.

By directly fabricating each shell, errors inherent in the replication process are removed. The principal challenge now becomes how to support the mirror shell during all aspects of fabrication, including the necessary metrology to converge on the required mirror performance specifications.

This program makes use of a Zeeko seven-axis computer-controlled polishing machine (see fig. 1) and supporting fabrication, metrology, and test equipment at MSFC.

The overall development plan calls for proof-of-concept demonstration with relatively thick mirror shells (5–6 mm, fig. 2) which are straightforward to support and then a transition to much thinner shells (2–3 mm), which are an order of magnitude thinner than those used for Chandra. Both glass and metal substrates are being investigated.

Currently, a thick glass shell is being figured. This has enabled experience to be gained with programming and operating the polishing machine without worrying about shell distortions or breakage. It has also allowed time for more complex support mechanisms for figuring/polishing and metrology to be designed for the more challenging thinner shells. These are now in fabrication.

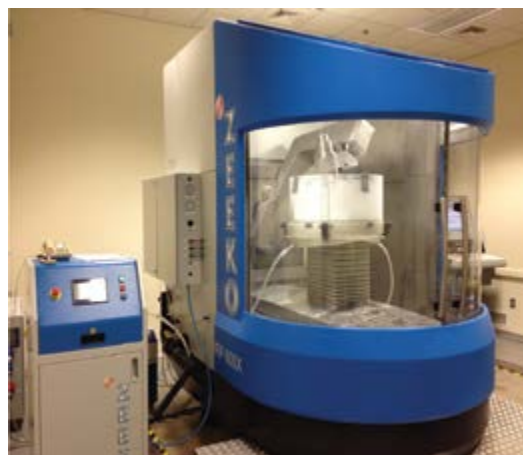

Figure 1: Zeeko polishing machine.



Figure 2: Thick glass shell on coordinate measuring machine.

Anticipated Benefits

Direct fabrication of individual full-shell optics, as was done with the Chandra program, can lead to the highest quality mirrors, far superior to those fabricated via replication processes of polished and figured masters or mandrels. Full-shell optics are inherently stable, due to their closed form and, particularly if they contain both ‘parabolic’ and ‘hyperbolic’ portions of the traditional Wolter-1 x-ray optics prescription, are easier to mount and align compared to other segmented optic approaches. These factors also lead to superior angular resolution for the final mirror assemblies.

The use of modern, automated polishing machines also helps reduce the overall cost of mirror fabrication. In addition, the use of commercially available machines potentially allows for easy transition to industry for future large-scale programs.

Potential Applications

A wide range of applications exist for lightweight, high-resolution x-ray optics. These range from small explorer class missions up to probe or even facility class observatories. Of particular interest at this time is the use of wide field x-ray optics for use in a survey-type astronomical instrument. By figuring special optical prescriptions, the resulting telescope can be made to have a flat angular resolution response over a relatively wide field. This makes possible a very efficient x-ray instrument for all sky surveys. Such surveys are routinely carried out at other wavelengths, but have not been done in x-rays since the early 1990’s. A wide field survey instrument could be realized on a probe class or even possibly a mid-size explorer class mission.

Notable Accomplishments

Custom fixturing has been designed and is under fabrication to provide the necessary level of support for all thin-shell fabrication steps including metrology (fig. 3). Further, special polishing tools have been developed to minimize the introduction of spurious ripple in the mirror figure that could degrade imaging performance. Software has been developed to stitch together metrology data and provide a direct input to the Zeeko polishing machine (fig. 4). In addition, machine control software has been written to adapt the Zeeko machine from normal incidence operation to grazing incidence optics fabrication.

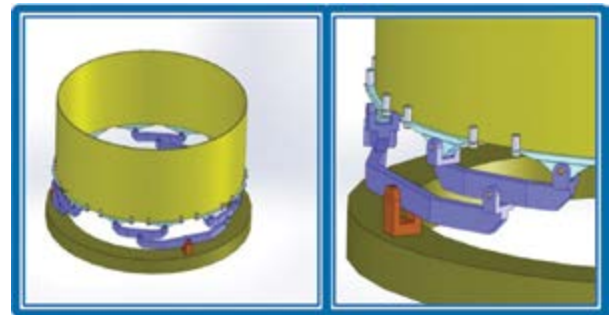

Figure 3: Metrology support stand for thin shell.

References

Roche; J.M.; et al.: “Mounting for fabrication, metrology and assembly of full-shell, grazing-incidence optics,” *SPIE*, Vol. 9144, doi: 10.1117/12.2057046, 2014.

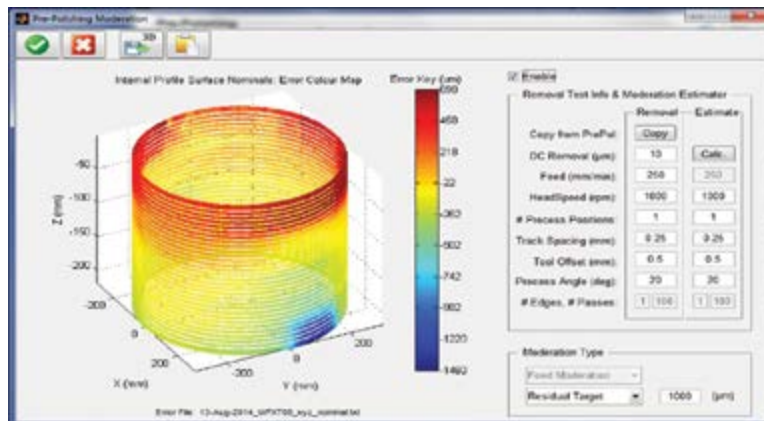

Figure 4: Metrology of test optic, stitched to provide full inside-shell coverage.