

THESIS FOR THE DEGREE OF DOCTOR OF PHILOSOPHY

Technical and Economic Conditions for
Efficient Implementation of CO₂ Capture

- process design and operational strategies for power generation and process industries

STEFANÍA ÓSK GARÐARSDÓTTIR

Department of Space, Earth and Environment

CHALMERS UNIVERSITY OF TECHNOLOGY

Gothenburg, Sweden 2017

Technical and Economic Conditions for Efficient Implementation of CO₂ Capture
- process design and operational strategies for power generation and process industries
STEFANÍA ÓSK GARÐARSDÓTTIR
ISBN 978-91-7597-637-2

© STEFANÍA ÓSK GARÐARSDÓTTIR, 2017.

Doktorsavhandlingar vid Chalmers tekniska högskola
Ny serie nr 4318
ISSN 0346-718X

Department of Space, Earth and Environment
Chalmers University of Technology
SE-412 96 Gothenburg
Sweden
Telephone + 46 (0)31-772 1000

Printed by Chalmers Reproservice
Gothenburg, Sweden 2017

Technical and Economic Conditions for Efficient Implementation of CO₂ Capture
– process design and operational strategies for power generation and process industries

STEFANÍA ÓSK GARÐARSDÓTTIR

Division of Energy Technology
Department of Earth, Space and Environment
Chalmers University of Technology

Abstract

This thesis investigates the operational parameters of fossil-based power generation and industrial processes in future energy systems that have stringent constraints on CO₂ emissions, and, consequently, large shares of renewable energy. CO₂ capture and storage, which is the focus of this work, is required for power and industrial processes that emit CO₂. This work investigates the heat requirement and the costs for implementation of CO₂ absorption in power and process industries, and the potential for thermal power with or without CO₂ capture to balance an electricity system with a large share of variable generation. The work uses modeling of: absorption-based CO₂ capture processes and coal-based power generation, under both steady-state and transient conditions; and the electricity system, which includes generation technologies with CO₂ capture.

It is shown that the specific heat requirement for CO₂ separation can differ by up to 1,000 kJ/kg of CO₂ captured between different processes industries, due to differences in the flue gas CO₂ concentrations. Furthermore, the volume of the CO₂ source is crucial in terms of the cost of CCS. Specific investment costs of 10–20 €/tCO₂ are estimated for large sources, such as steel mills, cement plants, and recovery boilers in pulp mills, as compared to >35 €/tCO₂ for small refinery stacks and lime kilns in pulp mills. Energy costs are, however, typically >20 €/t and represent the largest fraction of the total capture cost for large sources. This underlines the importance of a cost-effective heat supply, which can in some cases come from the excess heat in industrial processes. For an established system, the transport cost is modest. However, during ramp-up, the investments required for transport are of the same magnitude as those for the CO₂ capture plant.

On an energy systems level, the imposition of strict targets on CO₂ emissions has greater adverse effects on investments in flexible coal-based generation than enforcing strict targets on generation from renewables. Improving the cycling properties (minimum load levels and start-up times) of coal plants benefits the electricity system by ensuring higher capacity factors for wind and solar power, and increases the competitiveness of coal versus NGCC plants, by providing a similar level of operating flexibility at a lower cost. With the existence of strict CO₂ targets, CO₂ capture becomes a prerequisite for coal-based power generation. The load-following capability of coal-fired power plants is not significantly affected by the implementation of a CO₂ absorption process. In contrast, frequent cycling and operation with a decreased CO₂ capture rate are limited by the system due to increased emissions.

Keywords: *Post-combustion, chemical absorption, industrial sources, dynamic modeling, variable electricity generation, CO₂ capture and storage, CCS.*

List of publications

This thesis is based on the following papers, which are referred to in the text by their Roman numerals:

- I. Garðarsdóttir, S. Ó.; Normann, F.; Andersson, K.; Johnsson, F., *Post-combustion CO₂ capture using monoethanolamine and ammonia solvents: The influence of the CO₂ concentration on the technical performance*. Industrial & Engineering Chemistry Research, **2015**, 54, pp. 681-690.
- II. Garðarsdóttir, S. Ó.; Normann, F.; Skagestad, R.; Johnsson, F., *Investment costs and CO₂ reduction potential of carbon capture from process industry*. Submitted for publication, **2017**.
- III. Garðarsdóttir, S. Ó.; Normann, F.; Andersson, K.; Prölb, K.; Emilsdóttir, S.; Johnsson, F., *Post combustion CO₂ capture applied to a state-of-the-art coal-fired power plant – the influence of dynamic process conditions*. International Journal of Greenhouse Gas Control, **2015**, 33, pp. 51-62.
- IV. Garðarsdóttir, S. Ó.; Montañés, R. M.; Normann, F.; Nord, L. O.; Johnsson, F., *Effects of CO₂-absorption control strategies on the dynamic performance of a supercritical pulverized-coal-fired power plant*. Industrial & Engineering Chemistry Research, **2017**, 56, pp. 4415-4430.
- V. Garðarsdóttir, S. Ó.; Göransson, L.; Normann, F.; Johnsson, F., *Improving the flexibility of coal-fired power generators: impact on the composition of a cost-optimal electricity system*. Submitted for publication, **2017**.

Stefanía Ósk Garðarsdóttir is the principal author of all five papers. Associate Professor Fredrik Normann and Professor Filip Johnsson have contributed with discussions and the editing of all five papers. Professor Klas Andersson contributed with discussions and the editing of **Papers I and III**. Ragnhild Skagestad performed the economic calculations presented in **Paper II**. Dr. Katrin Prölb and Sóley Emilsdóttir contributed with discussions in **Paper III**. Rubén Mocholí Montañés contributed to the model development, discussions and editing of **Paper IV**, with Associate Professor Lars Olof Nord also contributing with discussions and editing of **Paper IV**. Dr. Lisa Göransson developed the modeling framework applied in **Paper V** and contributed with discussions and the editing of that paper.

Additional work has been carried out within the remit of the principal work, resulting in the publications listed below. These have not been included in the thesis, as the contents either overlap with the appended papers or are considered to be outside the scope of this thesis.

- A. Garðarsdóttir, S. Ó.; Normann, F.; Andersson, K.; Johnsson, F., *Process evaluation of CO₂ capture in three industrial case studies*. Energy Procedia, **2014**, 63, pp. 6565-6575.
- B. Garðarsdóttir, S. Ó.; Normann, F.; Johnsson, F., *Challenges for coal based electricity generation in energy systems with high capacity of variable renewable energy sources*. Proceedings of the 41st International Technical Conference on Clean Coal & Fuel Systems, **2016**.
- C. Normann, F.; Garðarsdóttir, S. Ó.; Skagestad, R.; Mathisen, A.; Johnsson, F., *Partial Capture of Carbon Dioxide from Industrial Sources – A Discussion on Cost Optimization and the CO₂ Capture Rate*. Energy Procedia, **2017**, 114, pp. 113-121.
- D. Alamia, A.; Garðarsdóttir, S. Ó.; Larsson, A.; Normann, F.; Thunman, H., *Efficiency comparison of large-scale standalone, centralized and distributed thermochemical biorefineries*. Energy Technology, **2017**, 5, pp. 1-15.
- E. Montañés, R. M.; Garðarsdóttir, S. Ó.; Normann, F.; Johnsson, F.; Nord, L. O., *Demonstrating load-change transient performance of a commercial-scale natural gas combined cycle power plant with post-combustion CO₂ capture*. International Journal of Greenhouse Gas Control, **2017**, 63, pp. 158-174.
- F. Montañés, R. M.; Garðarsdóttir, S. Ó.; Normann, F.; Johnsson, F.; Nord, L.O., *Power plant dynamics with post-combustion CO₂ capture - A comparison between a supercritical coal fired and a natural gas combined cycle power plant*. Proceedings of the 9th Trondheim CCS conference, **2017**.

Acknowledgments

The past five years have been an incredible learning experience for me and I have been lucky to collaborate with talented and inspiring people during my time as a PhD student. To my examiner, Filip Johnsson, thank you for sharing your vast knowledge and for providing much appreciated and valuable input. You really have a knack for seeing the big picture (and you have seriously impressive time-management skills)! Thanks to Klas Andersson, who introduced me to the division in my early days at Chalmers, provided guidance along the way, and sparked my interest in the field of CCS. My deepest thanks go to my supervisor, Fredrik ‘Fredster’ Normann. What a fantastic experience it has been to work with you! Thank you for countless discussions and, at times, much needed pep-talks. You have truly mastered the art of logical reasoning and of putting things into perspective (I hope that I will as well, one day!).

Thanks to colleagues at Tel-Tek, NTNU, and Modelon for fruitful collaborations, and special thanks to Rubén for times shared in Trondheim and Göteborg, whether in the office or out in the forest, getting slightly lost. Thanks also to my colleagues, former and current, at the Division of Energy Technology for creating such a friendly and inspiring environment in which to work. Honorable mentions go to Erik a.k.a. *chokladtomten*, Alberto, Sima, Anna, the forest *femmes*, and Energiteknik IK. To put everyday work in a social context is a wonderful thing. Also, thanks to the A-team for always taking the time to navigate a confused PhD student through the maze of travel bills and other administrative jungles, and to the Combustion Technologies/Oxy-fuel/What’s our name again? gang for all the interesting discussions and good times both at home and away (never forget, Florida!). Thomas, the best office roomie one could ever ask for and my good friend for 5 years: sharing wookie-cookies and perspectives on important things in life with you has been invaluable. Crafts and board games, anyone?

This work has been financially supported by the NORDICCS Centre, funded by the Top-level Research Initiative (project no. 11029), Statoil, Reykjavik Energy, Technology Centre Mongstad, Gassco, Norcem, and Vattenfall. Financial support from the Chalmers Energy Initiative, the Landsvirkjun Energy Research Fund, and the Swedish Energy Agency is also acknowledged.

Friends and family are an endless source of support, and for this I am grateful. A shout out to my PhD sista Jóna, whose moral support and reflections on the meaning of things can save the day. Special thanks to Sóley, who encouraged me to tag along to Sweden and study at Chalmers some 7+ years ago. To my rock ’n roll parents, Garðar and Anna, I am truly grateful. You have always supported me, been strong role models, and encouraged me to embrace every challenge in my path. Thanks to Steini and Svenni: the guidance and (occasionally, tough) love of two big brothers cannot be underestimated. And to Jónsi, my best friend and partner for so many years – your love and support means everything to me and I look forward to our future together, wherever it may take us!

Stefanía Ósk Garðarsdóttir

Selfoss, Ísland, 2017

Table of contents

Abstract.....	I
List of publications	III
Acknowledgments.....	V
Table of contents.....	VII
1 Introduction	1
1.1 Aims of the research.....	3
1.2 Outline of thesis	3
2 Background.....	5
2.1 CO ₂ capture through chemical absorption	5
2.2 CO ₂ absorption in industrial applications.....	8
2.3 Conditions for thermal power in future energy systems	10
3 Methodology.....	15
3.1 Modeling of CO ₂ absorption	16
3.2 Supercritical coal-fired power plant.....	17
3.3 Evaluation from an energy systems perspective	21
4 Results	25
4.1 Effects of CO ₂ source characteristics on the CO ₂ absorption process	25
4.2 Operation of a CO ₂ absorption process integrated into a coal-fired power plant	30
4.3 Flexibility of coal power – effects on electricity system composition and costs.....	38
5 Discussion.....	43
6 Conclusions	47
6.1 Considerations for future research	49
7 Bibliography	51

1 Introduction

Currently, around 80% of the world's primary energy supply comes from fossil fuels, with transport, industry, and the heat and power sector being the largest consumers [1, 2] (Figure 1.1). The awareness of climate change and the challenges that it poses for humanity has triggered a global effort to reduce anthropogenic emissions of greenhouse gases, especially carbon dioxide (CO₂) [3].

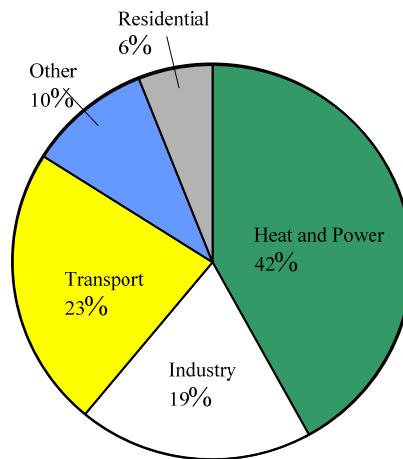

Figure 1.1: Shares of global CO₂ emissions from fossil fuel combustion by sector in Year 2014 [1]. The total emissions amounted to roughly 32 GtCO₂, which is equivalent to the emissions from combusting up to 600 Panamax shiploads of coal each day for a year.

Various measures exist to reduce CO₂ emissions from the different energy sectors. The transport sector focuses on electrification and the use of new energy carriers, such as bio-(blended) fuels and fuel cells [4]. In the heat and power sector, efforts are being made to reduce the intensity of emissions through improvements in efficiency and increased use of renewable energy, from wind, solar, and biomass sources, facilitated by various regional policies [5-7]. In the industry sector, there is a strong focus on fuel shifting, improved process integration, optimization, and efficiency [8]. These efforts are having important impacts on the use of fossil fuels.

Concerning the heat and power market, wind and solar power generation are considered as the new base-load providers, due to their low operating costs, when available, thereby forcing fossil-based power to operate on demand. The increased shares of intermittent wind and solar power are, thus, increasing the demand for regulating power in the electricity system. At present, fossil-fueled power plants allow for variable operation to cope with seasonal and daily

demand variations, and provide support services to the electric grid, i.e., grid frequency regulation. However, as the capacity of intermittent renewable energy sources increases, thermal power plants must also follow the variations in weather conditions for wind and solar power. Thus, fossil-fueled power plants face a dual challenge: to move away from their conventional role as base-load provider, and to reduce dramatically the intensity of CO₂ emissions.

The challenges for fossil fuel-dependent industries, such as those involved in oil refining, petrochemicals, cement, and iron and steel production, are often different from those faced by the power industry. Industrial processes generally operate under stable conditions that focus on maximizing productivity. The main challenge for these industries will be to meet long-term CO₂ emissions reduction targets, since in many cases the possibilities for fuel substitution, electrification, and further process optimization are limited [9].

Carbon capture and storage (CCS) is recognized as one of the technologies that will be required to mitigate climate change [10, 11]. Storage of CO₂, for example in depleted oil fields or saline aquifers deep under the ocean bed, reduces the amount of CO₂ released into the atmosphere. Thus, CCS technologies allow for the continued use of fossil fuels without substantial emissions of CO₂ to the atmosphere. However, the implementation of CCS requires extensive investment in infrastructure, and is generally considered to be limited in its application as a mitigation technology to large point sources of CO₂, such as power plants and industrial plants. Several methods exist for creating a CO₂-rich stream (CO₂ capture) from the processing of gases suitable for transport and storage - this work focuses on so-called ‘post-combustion capture’ based on CO₂ absorption. Post-combustion is often applied as an end-of-pipe technology that can be added as a step in the flue gas cleaning process to separate the CO₂ from the flue gases. Post-combustion capture can, in theory, be implemented at any point source of CO₂, such as an existing or newly built plant, whether it is a power production facility [12] or a process industry [13]. A post-combustion CO₂ absorption process that is integrated with a heat and power production process is depicted in Figure 1.2.

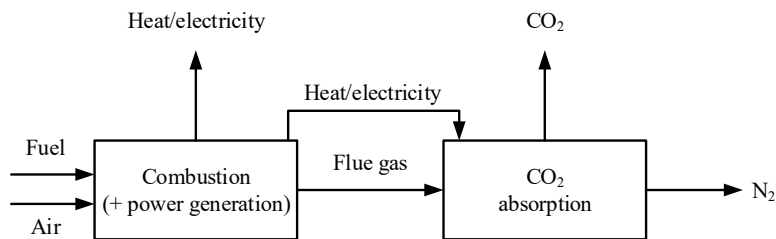

Figure 1.2: Schematic overview of the energy and material flows in a post-combustion capture or CO₂ absorption process applied to heat and power generation.

As CCS is the only viable option for exploiting fossil power while eliminating emissions of CO₂, any requirements related to variable operation must include the capture process. Achieving a solid understanding not only of the steady-state operation, but also the dynamic operation of an integrated power plant and CO₂ capture process is necessary for ensuring that the implementation of CO₂ capture is both technically and economically feasible. Elucidating the role of fossil power in an electricity system that is facing both restrictions on CO₂ emissions

and requirements for increased variable operation is crucial for facilitating the transition to a low-carbon generation through large-scale integration of intermittent renewable energy sources. It seems likely that the stringency of the requirements for variable operation of thermal plants will differ significantly between regions, reflecting cross-border transmission capacities for the import/export of electricity and local conditions for wind and solar power, as well as the availability of other balancing power.

For the process industry, carbon capture is needed to achieve the deep emission reductions set out by international climate goals [14]. Identifying conditions for efficient integration of CO₂ capture into the process industry is therefore essential and requires industry-specific investigations from both the technical and economic perspectives. Furthermore, identifying feasible transport and storage solutions at the regional level is vital for the realization of full-chain CCS.

1.1 Aims of the research

The overall objective of this work was to investigate the operation and design of fossil-based power generation and industrial processes in future energy systems that impose strict constraints on CO₂ emissions and, consequently, have large shares of renewable energy. More specifically, the work investigates the application of CO₂ absorption to thermal power generation and process industries, and evaluates the potential for thermal power plants to provide variation management to the electricity system. Variation management refers to the use of strategies to meet the net load curve (the residual load), with flexible thermal power generation being one option. The work includes the following specific objectives:

- i) Evaluate the effects of flue gas characteristics on the design and cost of the CO₂ absorption process.
- ii) Evaluate the operation of CO₂ absorption under transient and off-design conditions, including the implementation of control strategies.
- iii) Evaluate the effects of the competitiveness of coal-fired power plants on the generation mix and system cost in electricity systems that have strict restrictions on CO₂ emissions.

1.2 Outline of thesis

This thesis consists of an introductory essay and five appended papers. The six chapters of the essay put the work in context and summarize the findings of the appended papers. Chapter 2 provides the background to the research field. The methodology of the work is presented in Chapter 3, and the specific methodological approach taken in each paper is briefly described. The main results from the appended papers are summarized in Chapter 4, and a discussion of the work is presented in Chapter 5. Finally, concluding remarks and recommendations as to future work are given in Chapter 6. In brief, the appended papers cover the following topics:

Paper I investigates the effects of flue gas CO₂ concentrations on the steady-state performance of the CO₂ absorption process. The range of CO₂ concentrations investigated represents typical emissions sources associated with large-scale industrial applications. The paper focuses on the relationships between important design parameters and solvent characteristics.

Paper II presents an estimate of the investment required to implement CO₂ absorption at industrial sources of CO₂ and discusses those conditions that have an important bearing on the operating costs, in a case study of the Swedish process industry. The findings from **Paper I**, with respect to the design of the absorption process such that it relies adapts to the flue gas CO₂ concentrations, are applied and their effects on capture costs are discussed.

Papers III and IV investigate the transient behaviors of the CO₂ absorption system during load changes in a coal-fired power plant. These papers focus on process control strategies for the capture unit and their influences on power plant performance. In **Paper III**, a dynamic CO₂ absorption model is soft-linked to a steady-state power plant model, in order to evaluate power plant performance under full-load and off-design conditions. In **Paper IV**, a dynamic power plant model is developed and directly linked to the CO₂ absorption model, to investigate further the transient performance of the integrated system in different modes of operation.

Paper V explores the role of thermal plants, with and without CO₂ capture, in future electricity systems that have strict constraints on CO₂ emissions and a high penetration of variable renewable electricity generation. The focus is on possibilities to improve the operational flexibility of coal-based power plants, and specifically, to investigate if and how investments in coal-based power affect other power generation technologies and, consequently, the electricity system costs.

Figure 1.3 is a graphical overview of the relationships between the appended **Papers I–V**, showing which processes and systems are investigated in each paper and the particular modeling approach that is applied, i.e., steady-state or dynamic process modeling, or energy systems modeling.

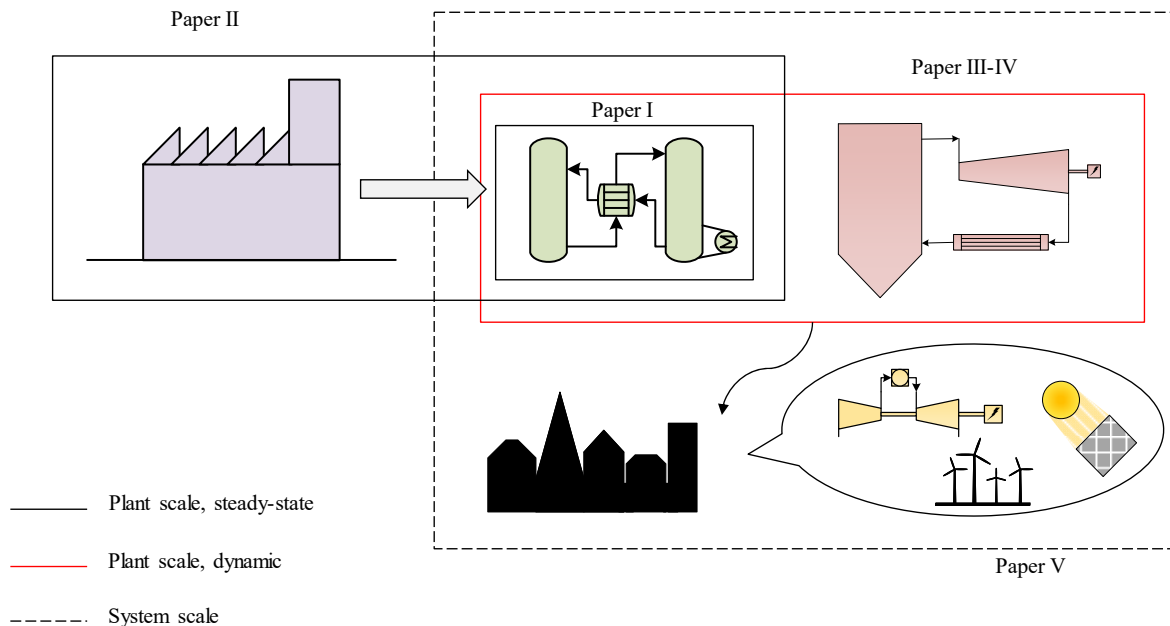

Figure 1.3: Overview of the areas explored in the thesis and the relationships between the research topics of the appended papers.

2 Background

CO₂ separation or “capture” has been used in industrial processes since the beginning of the 20th Century. In the early years (and up to the present day), most of the CO₂ capture processes were used to upgrade the natural gas found in reservoirs into a sellable product [15]. In the 1970’s, CO₂ capture was first proposed as a way of storing CO₂ in isolation from the atmosphere, so as to reduce the greenhouse effect. The 2000’s was the “golden age” of CCS, with multiple CO₂ capture technologies being developed, primarily aiming at large-scale demonstration of coal-fired power plants with CO₂ capture by around 2015. However, the plans for these demonstrations were not realized for various reasons, such as public acceptance problems and lack of financial support. An exception is the Boundary Dam Carbon Capture project, which can be regarded as a commercial project because the captured CO₂ is sold as a product for enhanced oil recovery. Nonetheless, there is still a considerable amount of research being conducted on various aspects of CCS. This research is increasingly focusing on large-scale industrial applications, the effects of deployment of CCS on energy systems, and the continued development of various CO₂ capture technologies. The so called ‘post-combustion capture’ technique based on the absorption of CO₂ in an amine solvent is seen as the benchmark technology, and is ready for full scale-implementation. This chapter summarizes the findings regarding CO₂ absorption by amine solutions, CO₂ capture from industrial processes, and the conditions for thermal power in future energy systems of importance to the theme of this thesis.

2.1 CO₂ capture through chemical absorption

A simplified process scheme for a post-combustion capture system based on chemical absorption is presented in Figure 2.1. In this setup, the flue gas, or the diluted CO₂ stream, is introduced at the bottom of the absorber. The CO₂-lean solvent is introduced in a countercurrent manner to the flue gas at the top of the absorber. The solvent reacts selectively with CO₂ and removes it from the flue gas stream in the absorber. The remaining flue gas, which mainly consists of N₂, is released into the atmosphere. The CO₂-rich solvent that exits the absorber enters the stripper. The stripper operates at a higher pressure and temperature than the absorber to reverse the chemical reactions and release gaseous CO₂ from the liquid solvent. Heat is usually added to the process in the form of steam in the stripper reboiler. The solvent leaves the stripper in a CO₂-lean form and is cooled before it is reused in the absorber. A heat exchanger placed between the absorber and the stripper recovers heat from the CO₂-lean solvent. After leaving the stripper, the almost-pure CO₂ stream passes through a condenser to reduce the water content. Finally, the highly-concentrated CO₂ stream is compressed and

prepared for transport and storage. Important design parameters of the absorption processes considered in this work include the:

- **Solvent concentration**, which describes the amount of solvent contained in the liquid solution. It is usually given in wt% solvent of an unloaded (i.e., CO₂-free) solution. The concentration may vary widely depending on the solvent, from as low as 5wt% to more than 40wt% [16-18]. The solvent is diluted in water.
- **Liquid-to-gas (L/G) ratio**, which is the ratio of the amount of liquid to the amount of gas entering the absorber. It is usually given in mol/mol or kg/kg.
- **CO₂-loading**, which is a measure of the amount of CO₂ present in the liquid solvent. Loading is usually specified in mol CO₂/mol solvent. The CO₂-loading varies between the two levels in the process, with a low level at the stripper outlet/absorber inlet (referred to as ‘lean solvent loading’) to a high level at the absorber outlet/striper inlet (referred to as ‘rich solvent loading’). The optimal CO₂-loading is influenced by the solvent characteristics, such as absorption capacity and reaction kinetics, as well as by other design parameters, such as residence time. For most solvents, the CO₂-loadings are within the range of 0.2–0.5 mol CO₂/mol solvent [17].
- **Specific heat requirement**, which describes the amount of heat required in the stripper reboiler to separate the CO₂ from the liquid solvent. It is usually given in kJ/kg CO₂ captured. The specific heat requirement varies significantly with the process, and is strongly influenced by the CO₂ loading, solvent concentration, and L/G ratio, as well as by the solvent characteristics. The separation of CO₂ from the liquid solvent is relatively energy-intensive and the specific heat requirement is often in the range of 3,000–4,000 kJ/kg CO₂, although lower values have been claimed for novel solvents [18, 19]. Energy dominates the capture cost, and research on the absorption of CO₂ has focused strongly on optimizing the process and reducing the energy requirement [20].
- **CO₂ capture rate**, which describes how much of the CO₂ in the flue gases is captured by the capture process. The CO₂ capture rate is a design parameter, and the most common practice is to design for a high CO₂ capture rate; a rate in the range of 85%–95% is considered feasible for the absorption process.

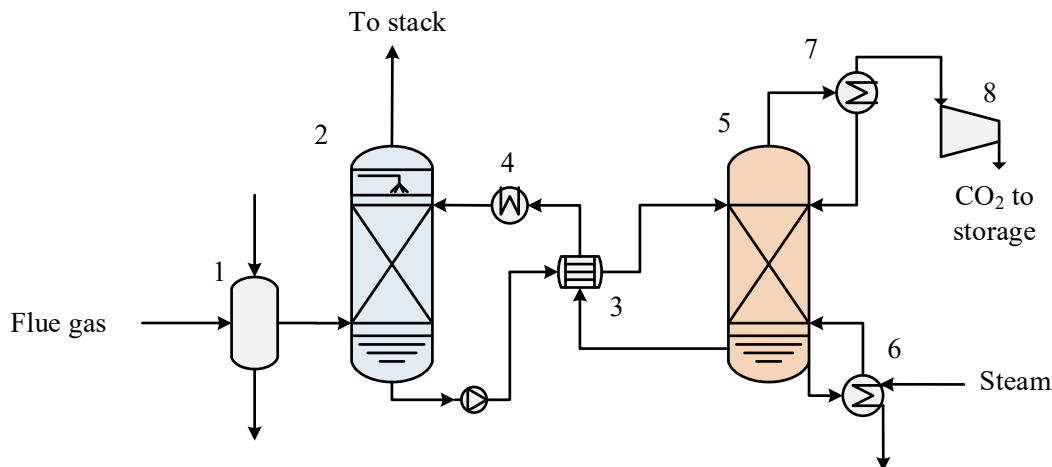

Figure 2.1: Schematic overview of a typical post-combustion CO₂ capture process based on chemical absorption. 1, Flue gas conditioning; 2, CO₂ absorber and washing section; 3, solvent heat exchanger; 4, solvent cooler; 5, CO₂ stripper; 6, stripper reboiler; 7, product condenser; 8, CO₂ compression.

2.1.1 Solvents

The solvent is a crucial component of the chemical absorption system. Desirable characteristics of the solvent include: a low heat requirement for regeneration; high level of reactivity with CO₂; high absorption capacity; low cost; low volatility; resistance to degradation; and low toxicity. The most commonly used solvents are amines and amine blends. Pure monoethanolamine (MEA) is the benchmark solvent in both theoretical and experimental studies, as it represents a broadly available, simple, and well-proven technology [17]. However, it should be noted that pure MEA is not the most energy- or cost-effective solvent - its main disadvantages relative to more advanced solvents are a relatively high specific heat requirement, high rate of degradation, and low absorption capacity.

More advanced solvents, which are superior to MEA with respect to many of the desired features, include blends of various primary, secondary, and tertiary amines, e.g., MDEA, DEA, TEA, and sterically hindered amines, such as AMP [21]. The solvents in commercial CO₂ absorption applications are amine-based blends, the most notable of which are Shell's Cansolv CO₂ capture solvent [22], Mitsubishi's KS-1 [19], Fluor's Econamine Plus [23], and Aker Solutions' advanced amine [24].

Ammonia and the amine piperazine (PZ) are other examples of solvents that have received attention as a viable alternative to MEA [18, 25, 26]. Of these solvents, concentrated aqueous PZ has received the most attention [21]. Compared with MEA, PZ has a high absorption rate, low specific heat requirement (<3,000 kJ/kg CO₂ captured), low volatility, and high resistance to degradation. The main disadvantages of PZ are its narrow CO₂-loading range (owing to precipitation issues), higher solvent cost, and the complex design of the solvent regeneration system (due to the more complex process chemistry, requiring zwitterions and precipitation, to describe the PZ-CO₂-H₂O system) [18]. The main advantages of ammonia are high resistance to degradation, low cost, and low specific heat requirement, as compared to MEA. Ammonia is, however, relatively volatile and requires access to low-temperature cooling water and a relatively high CO₂ content in the flue gas stream. The main disadvantages are slower reaction

kinetics and volatility, which requires significant efforts to minimize solvent slip [26]. Other novel solvents include biphasic solvents and ionic liquids, although much additional research is needed to address several issues identified with these technologies, such as volatility and degradation, before they can be applied in larger-scale pilot or demonstration plants [27, 28].

Although many solvents have been shown to be superior to MEA, no single solvent stands out as the obvious choice or possesses all the desired characteristics listed above [20]. The energy requirement for solvent regeneration remains a challenge, and as more CO₂ capture plants become operational on a large scale, post-build issues, such as corrosion, degradation, and solvent emissions, are of increasing concern. Thus, continued efforts are being made in the laboratories of both academic institutions and private companies to improve the performance profiles of existing solvents and to develop new technologies for the efficient absorption of CO₂.

In this thesis, **Paper I** evaluates the influence of the solvent on the process design by comparing the performances of MEA and ammonia solvents under various process conditions that are representative of industrial sources of CO₂. **Papers II–IV** focus on the benchmark solvent MEA – **Paper II** for industrial applications and **Papers III** and **IV** for power plant applications.

2.2 CO₂ absorption in industrial applications

As mentioned in Section 2.1, CO₂ absorption is used in several industrial processes, such as natural gas sweetening, the production of ammonia, and syngas upgrading and synthesis. CO₂ absorption for emissions reductions in the process industry has become an important research topic in recent years and has attracted an increasing number of large project initiatives. Large-point sources of CO₂ emissions, such as pulp and paper, (petro)chemical, and ferrous and non-ferrous metal plants, all emit substantial amounts of CO₂ and are therefore of interest with respect to carbon capture.

In 2012, Kuramochi et al. [29] presented a comprehensive literature review and a comparative techno-economic assessment of CCS for several key industries, namely oil refineries, petrochemicals, cement, and iron and steel. A brief mention was also made of studies that have included the pulp and paper industry. Considering CO₂ absorption, they emphasized the importance of identifying feasible conditions for process integration and its influence on plant economics.

More recent studies focusing on the **steel industry** have been the techno-economic studies carried out by Arasto et al. [30], Tsupari et al. [31], and Hooey et al. [32], as well as the European research program Ultra-Low CO₂ Steelmaking (ULCOS), in which research and development projects on a variety of methods for CO₂ emissions reductions in the steel industry, including CO₂ capture, were undertaken [33]. The study of Tsupari et al. [31] highlights the complexity of modern steel mills, which consist of several point sources, and looks into how the levels of excess heat utilization and process integration affect costs. The first commercial CO₂ capture facility in the iron and steel industry was launched in 2016, in the Emirates Steel plant in Abu Dhabi [34].

Recent studies on the application of CO₂ absorption to **cement plants** include the report from the European Cement Research Academy (ECRA) in collaboration with IEAGHG [35], which focused on Norcem's plant in Brevik, Norway, where several CO₂ capture technologies have been tested (see for example, Mathisen et al. [36], Bjerger and Brevik [37], Jakobsen et al. [38]). These studies show that the cement industry is a good candidate for CO₂ capture using various approaches, such as absorption-based technologies, calcium looping, and oxy-fuel combustion. It has also been pointed out, for example by Jakobsen et al. [38], that the possibility for cost reduction through excess heat utilization is highly dependent upon the moisture content of the raw material, as lots of process heat is required to dry the raw material, thereby underlining the importance of site-specific studies.

CO₂ capture from the **refining and petrochemical industries** has been investigated by van Straelen et al. [39], Meerman et al. [40], Johansson et al. [41], Berghout et al. [42], and Andersson et al. [43], among others. From these studies, it is evident that case-specific investigations are needed to address the heterogeneity of the industry sector, especially in the case of oil refineries where the estimated costs cover a wide range, as reported in studies in the literature and even within studies that consider multiple capture cases. The plant-level design details and energy market conditions of the specific geographic area are important to consider in estimating the cost of the capture plant. Many facilities in the refining and petrochemical industry contain highly concentrated CO₂ sources and favorable conditions for excess heat utilization. CO₂ absorption from refining and petrochemical-related processes has been demonstrated at several plants around the world, including: at Shell's Quest facility in Canada [44], where it is applied in a hydrogen production unit; at Sinopec's refinery in He'Nan Province in China [45], where CO₂ is captured from a fluid catalytic cracking unit; and at Statoil's refinery in Mongstad, Norway, where different solvents have been tested on flue gases emanating from the refinery's power plant and from the fluid catalytic cracker [46, 47].

The **aluminum production industry** is also a substantial emitter of CO₂. However, the techno-economic studies conducted by Lassagne et al. [48] and Jilvero et al. [49] revealed the difficulties associated with implementing CO₂ capture at the present-day aluminum smelter due to the low flue gas CO₂ concentrations (~1 vol%), and they suggested that a modified design of the aluminum production process is required for CO₂ capture to be technically feasible for this industry. No pilot or demonstration plants have been reported in the literature for the aluminum industry.

The **pulp and paper industry** is special in that its CO₂ emissions originate primarily from biogenic sources. Thus, less attention has been focused on CO₂ abatement in this industry compared to fossil-fueled industries. No pilot or demonstration initiatives focusing on CCS has been established to date for the pulp and paper industry, even though the levels of emissions from its plants are comparable to those of other industries. The concept of combining bio-energy with CCS, known as BECCS, is therefore applicable to the pulp and paper industry. Several studies have been published on this subject (see for example, Möllersten et al. [50], Hektor [51] and the more recent work of Onarheim et al. [52, 53]). Overall, these studies conclude that there is a significant potential for implementing CO₂ capture technologies in the pulp and paper industry, where favorable opportunities for heat integration may exist [52].

Furthermore, Pettersson and Harvey [54] have highlighted the potential of combining the CO₂ capture technology with alternative production routes, such as the production of biofuels.

The general characteristics of the industries considered for CO₂ capture are summarized in Table 2.1. Many of the industrial processes have more than one CO₂ source at the plant site and the flue gas streams vary in terms of flow and composition. The general conclusion drawn from the studies on industrial CCS applications is that the potential for CO₂ capture, and consequently the cost, varies considerably between the industrial sectors assessed, and even within the specific industrial sectors due to the heterogeneity of the plants and the range of local conditions.

Table 2.1: Characteristics of large-scale emissions-intensive industries of importance regarding the implementation of CO₂ capture.

Industry	CO ₂ sources	Flue gas CO ₂ content (vol%)	% of site emissions	Possible source(s) of heat
Pulp and paper	Recovery boiler	13	75	Steam cycle
	Lime kiln	20	10–15	
Refineries	H ₂ production unit	24	30	Process heat
	Combined stacks	8–14	5–30	
Iron and steel	Power plant	30	40	Steam cycle and process heat
	Other stacks	20–25	15–20	
Cement	Combined stacks	20	90	Process heat
Aluminum	Smelting cells	1–4	70	Process heat
Petrochemicals, ammonia	Process heaters, water-shift reactors, cracker furnaces, other	5 – high purity	Process-specific	Process heat

The influences of the characteristics of the industrial source on the design and technical performance of the CO₂ absorption process are described in **Paper I**, for MEA and ammonia solvents. Subsequently, in **Paper II**, the investment required to implement an MEA-based CO₂ absorption process for the various industrial sources is investigated. Aspects related to the operating and total capture costs of the absorption process are discussed, especially with respect to excess heat utilization.

2.3 Conditions for thermal power in future energy systems

The existence of a high capacity of variable renewable electricity in an energy system has consequences for the operation and profitability of thermal power plants (coal-fired and gas-fired) [55-59]. A general observation is that the operating costs for electricity generation from variable renewables, i.e., wind and solar energy, are close to zero, much lower than those for thermal power generation. Therefore, when it is available, generation from variable renewables is positioned early in the dispatch order, thereby limiting or eliminating the base-load provision from thermal power generators. Variable, or flexible, operation of thermal power generators, which operate as mid-merit generators with a variable demand, has been identified as a way to balance the electricity system. Other options include increased transmission capacity, energy storage, demand-side management, and the use of electricity in other sectors, such as

transportation (electro-fuels) and district heating. Identifying cost-effective options to balance regional electricity systems will depend strongly on the following market conditions:

- Fuel prices
- Local resources
- Price of emitting CO₂
- Technology mix in the electricity system
- Electricity price
- Load curve characteristics
- Wind and solar conditions
- Possibilities for transmission capacity expansion

Many of these balancing options are still considered immature and, in addition to market conditions, the evolution of the various options will be important to the development of the energy system. In **Paper V**, the role of thermal plants, with and without CO₂ capture, are investigated in future electricity systems with different conditions for variable renewables and fossil fuels. The effects on the operation of a single power plant equipped with CO₂ absorption for rapid load-following conditions are investigated on a second-to-second timescale in **Papers III and IV**.

2.3.1 Development trends for the flexibility of coal-fired power generators

The growth in use of variable renewables in the electricity system is foreseen, and the thermal power generation industry is working to increase both operational and fuel flexibility, so as to improve the competitiveness of thermal power plants. In this thesis, operational flexibility is of primary concern. Efforts to increase operational flexibility include the development of materials, control systems/strategies, and process setups for newly built plants, as well as for the retrofitting of existing plants [60, 61]. The operational flexibility of thermal power plants depends on several factors, often referred to as their cycling properties:

- **Minimum load/turn-down** describes the operable load range of a power plant. The possibility to operate at low loads reduces the number of shut-downs. Currently, the minimum load levels are in the ranges of 35%–40% for lignite-fired plants and 25%–30% for hard coal-fired plants, and are expected to reach 10%–15% for retrofitted and new systems. [60, 62-64]
- **Part-load efficiency** is the efficiency of the plant operating off-design, i.e., in part-load mode. For a plant that is operated at various loads, a high part-load efficiency obviously increases its competitiveness.
- **Start-up time** is the time needed for a plant to progress from a stand-still to full-load operation. The start-up process can be divided into three categories (hot, warm and cold), depending on how long the plant has been out of operation. Cold start-ups are the costliest, mainly due to the long warm-up phase. Warm-up is usually performed with oil or gas, which are more expensive than coal, and there is no output of electricity during this phase. The start-up times for coal-fired plants are usually in the range of 2–12 hours, depending on the type of start, and are expected to be reduced by 50% with

ongoing development efforts. The **start-up emissions** are also of importance, as emission control systems are not fully operational during the start-up phase [60, 64-69].

- **Ramp rate** describes the rate of change in the power plant output, usually expressed in MW/min or the percent of rated power/min. The ramp rate is in practice typically limited by the delays and dead-times in the fuel transportation process, i.e., in the fuel mills. It is also important to limit the thermal stress on process equipment, primarily thick-walled components, in efforts to shorten the response time of the power plant. Typical ramp rates for modern coal-fired plants are in the range of 2%–5% per min, depending on the load range within which they are being operated, with development efforts aiming to achieve ramp rates of up to 10%/min to match those of gas turbines [60, 70].

The possibilities for making investments to improve the flexibility of coal-based power plants with respect to cycling properties are investigated in **Paper V**. In particular, the consequences for electricity system costs of investments in improved coal-based flexibility are evaluated.

2.3.2 Operation under transient conditions with CO₂ capture

The integration of post-combustion CO₂ capture processes with a power plant has been studied in a number of technical and economic analyses, which have been published in the literature (see, for example, the reviews of Wang et al. [17] and Goto et al. [71] and references therein). Most of these studies have focused on optimizing the design of the capture process, as well as the connection to the power plant under design conditions, i.e., full load and steady state, and applied to power production from coal combustion, due to the large share of coal in the global power generation mix. As depicted in Figure 2.2, the capture process and the power plant are highly integrated, which results in a strong demand for efficient process control and operational strategies suited to varying market conditions.

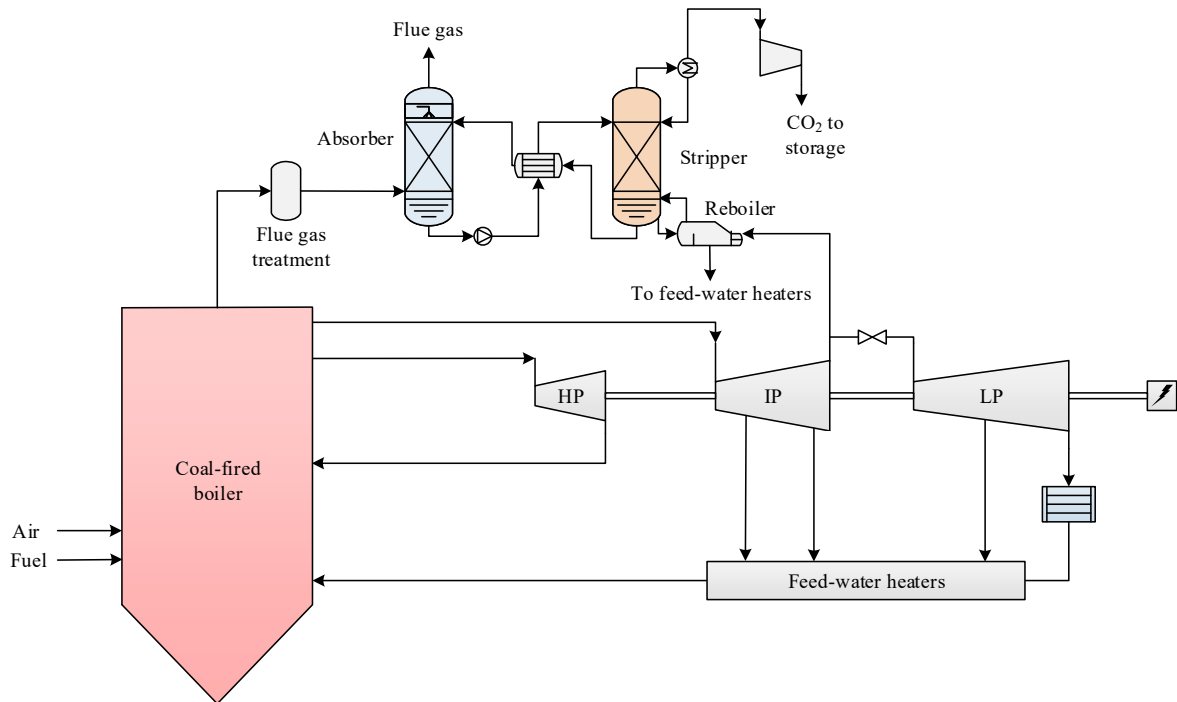

Figure 2.2: Schematic overview of a CO₂ absorption process that is integrated with a coal-fired power plant.

The interest in power plant transients with and without carbon capture is relatively new. Data for model validation during dynamic operation of CO₂ absorption pilot plants are scarce, although some recent efforts have been made [72-74]. Bui et al. [75] presented a detailed review of the dynamic modeling of post-combustion capture systems integrated with power plants and highlighted several modes of operation of the integrated system, depending on which ancillary services the power plant should provide to the electricity system. The two specific operating modes investigated in this thesis are listed in Table 2.2.

Table 2.2: Transient power plant operating modes investigated in the thesis.

Power plant operation	CO₂ absorption process operation
Part-load operation to follow system demand	Control of process variables to maintain technical performance
Increase in maximum power output to meet a short-term power deficiency	Decrease in the steam availability to the capture process, and consequently, in the CO ₂ capture rate

In this thesis, two approaches to investigate the effects of power plant transients on the CO₂-absorption process are evaluated: (i) modeling of a CO₂-absorption plant with the power plant transients being represented by boundary conditions; and (ii) modeling of the integrated system, as depicted in Figure 2.2, in which potential interactions between the two non-linear feedback systems, i.e., the CO₂-absorption process and the power plant, are considered.

Several recently reported studies based on the former approach (e.g., [76-82]), have proposed process control strategies for the CO₂ capture process for load-following and peak-load operation, with the goals of improving the efficiency and response time of the capture system. Walters et al. [83] have presented a dynamic model of a CO₂-absorption plant with boundary

conditions taken from a steady-state power plant model. They concluded that a one-sided focus on any one of the subsystems, i.e., the power plant, CO₂-absorption plant or a downstream Enhanced Oil Recovery (EOR) facility, would make the dynamic performances of the other subsystems suffer. A similar approach was used by Mac Dowell and Shah [84], [85], i.e., in which a simplified model of a sub-critical power plant specified the flue gas flow and composition, as well as the state of the steam supplied to the dynamic CO₂-absorption model. They concluded that operating with either a time-varying solvent regeneration or a solvent storage system would increase plant profitability, as compared to operating with a relatively constant CO₂-capture rate under load-following conditions.

Applying the latter approach, Lawal et al. [86] developed a dynamic model of a sub-critical, coal-fired plant integrated with CO₂ absorption, and they showed that the CO₂ absorption process has a slower response to load changes than the power plant, and that control loops in the capture process may interfere with power plant control loops. More recently, Wellner et al. [87] developed an integrated dynamic model of a supercritical, coal-fired plant with CO₂ absorption. They concluded that reliable primary frequency control could be provided by the integrated system by redirecting steam from the CO₂-absorption process to the power plant. A recent study published by IEAGHG [88] assessed various control strategies for the CO₂ absorption process in a similar model. They concluded that during slow load changes (in terms of hours), simple and well-tuned control strategies are sufficient to maintain proper operation of the CO₂ capture plant. They also identified a need for continued development of dynamic models for all the processes within the CCS chain, to allow evaluations of the impacts of faster load changes and ease of integration between the power plant and the CO₂ capture plant.

Therefore, questions remain as to how the integrated system behaves and should be controlled, and there is a need for the development of system models that explain better the interactions that occur between the power plant and the capture process. In this thesis, implementation of carbon capture at a state-of-the-art, coal-fired power plant is investigated with respect to the operational performance of the integrated processes under transient load conditions. In **Paper III**, a dynamic CO₂ absorption model is soft-linked to a steady-state power plant model. In **Paper IV**, a dynamic power plant model is developed and directly integrated with an improved version of the CO₂ absorption model applied in **Paper III**.

3

Methodology

The work presented in this thesis is based on the modeling of absorption-based CO₂ capture processes and coal-based power generation, under both steady-state and transient conditions, and electricity system modeling which includes generation technologies that are equipped with CO₂ capture. Figure 3.1 presents an overview of the modeling tools used in the thesis and relates them to the topics of the appended papers. The steady-state modeling includes investigations of the post-combustion process based on the use of two absorbents, MEA (**Papers I, II and IV**) and ammonia (**Paper I**), as well as the use of a detailed model of an existing state-of-the-art, coal-fired power plant (**Paper III**). Furthermore, a steady-state model is developed in **Paper IV** as a simplified representation of a modern coal-fired power plant, to provide data for a dynamic power plant model. The dynamic modeling includes investigations of MEA-based absorption (**Papers III and IV**) and thermal power generation based on pulverized coal (**Paper IV**). A cost-minimizing investment model is applied to three regional electricity systems in **Paper V**.

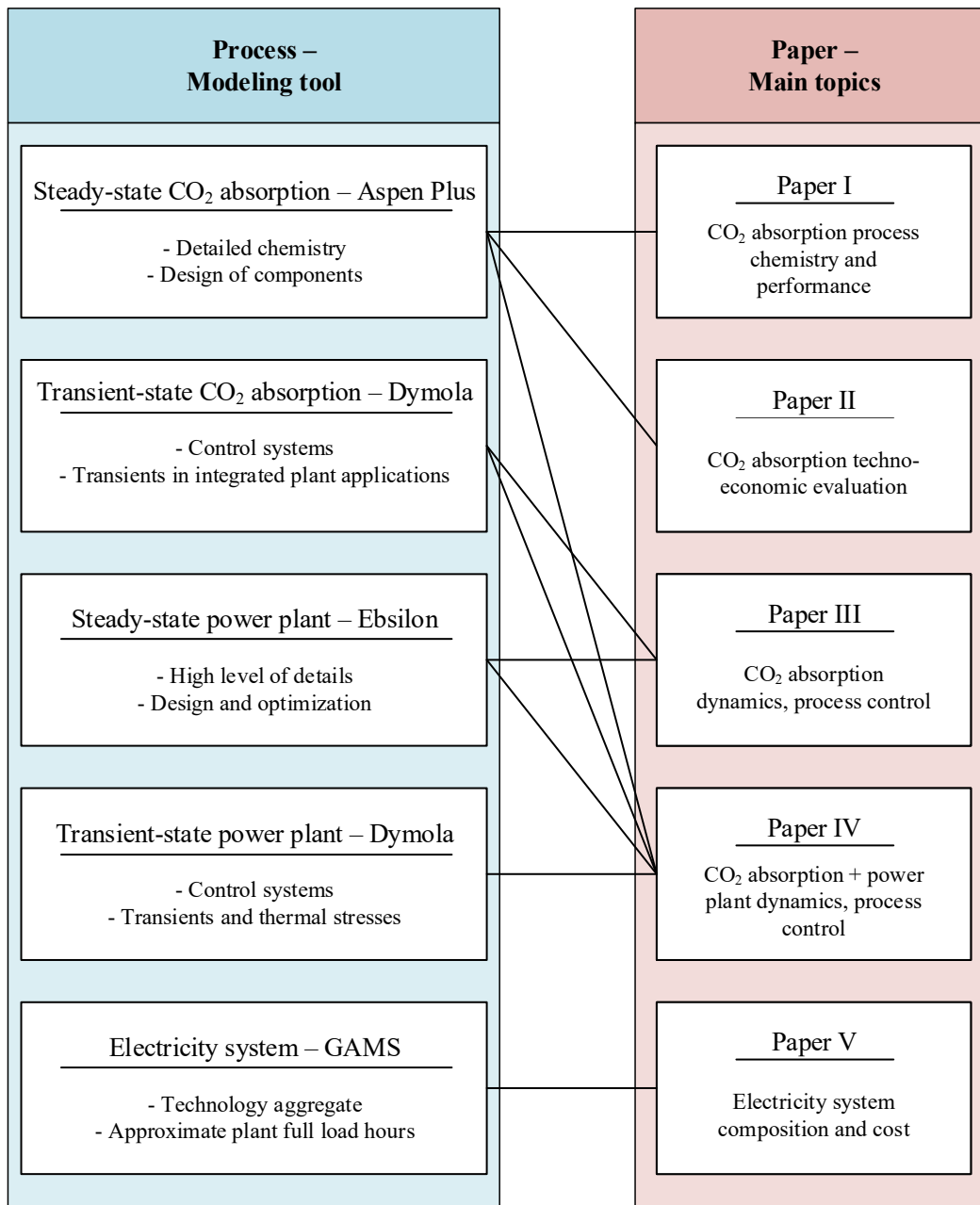

Figure 3.1: Overview of the modeling tools used in the thesis related to the topics covered in the appended papers.

3.1 Modeling of CO₂ absorption

3.1.1 Steady-state conditions

The steady-state models of the capture process developed in **Paper I** use a rate-based approach, and include the mass transfer limitations and reaction kinetics of the absorber and the stripper. The mass transfer between the gas and liquid phases is described by the two-film theory. The absorption columns are modeled as multi-stage packed columns. Both models utilize the Aspen Plus built-in electrolyte NRTL method and the Redlich-Kwong equation of state for computing the properties in the liquid phase and vapor phase, respectively. The thermodynamic models

used for simulating the MEA-based and aqueous ammonia-based absorption systems have been described in detail by Zhang et al. [89] and Que and Chen [90], respectively. The reaction mechanisms are described in **Paper I**.

A schematic of the model setups is presented in Figure 3.2. The ammonia-based process implements a staged absorption setup with intercooling between the two absorption columns, as depicted in Figure 3.2b, to reduce the slip of ammonia to the CO₂-lean flue gas [26]. It is important to note that a top cycle should be added to the ammonia absorption system to recover ammonia from the exhaust gas (see Jilvero et al. [16]). In the present work, the heat required in the top cycle has been estimated based on the work of Jilvero [26].

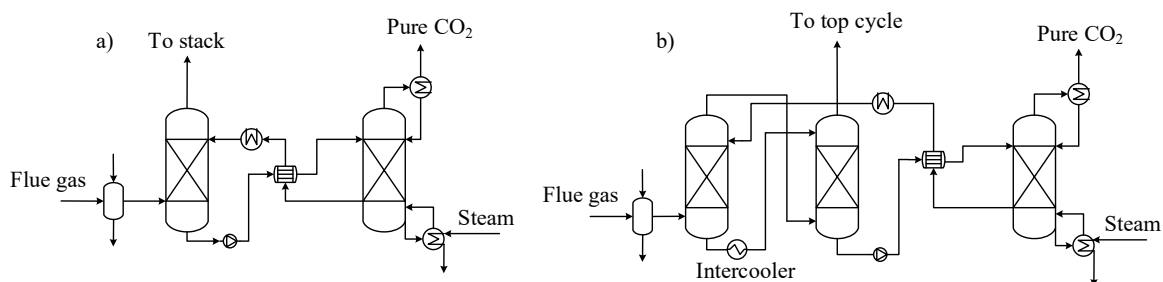

Figure 3.2: Schematic overviews of: a) the MEA-based process; and b) the staged-absorption setup in the ammonia-based process.

The modeling framework developed and presented in **Paper I** is used in **Paper II** and **Paper IV** to design the CO₂ absorption process with respect to specific emission sources. This includes the design of the geometry of the columns and the washing section of the absorber, the heat-exchanger area in the lean-rich heat exchanger, and the rich-loading and lean-loading of the solvent under design conditions. In **Paper IV**, the design that was derived through steady-state modeling is subsequently applied in the dynamic CO₂ absorption model, as discussed in Section 3.1.2.

3.1.2 Dynamic conditions

The dynamic model of the MEA-based capture process presented in **Papers III** and **IV** is similar to the steady-state model in that a rate-based approach based on the two-film theory is used to describe the mass transfer between the gas phase and liquid phase. The columns in the dynamic model are modeled as multi-stage packed columns. However, to simplify the model, the chemical reactions in both the absorber and the stripper are assumed to reach equilibrium, and MEA is assumed to be non-volatile in the dynamic model. The effects of chemical reactions on the concentration profile near the gas-liquid interface are instead accounted for in the mass transfer calculations through the application of an enhancement factor. The dynamic model developed in this thesis is based on the model framework presented previously by Åkesson et al. [91], and consists of components from Modelon's Gas-Liquid Contactors Library [92]. For a more detailed description of the model framework and assumptions, see **Papers III** and **IV**.

3.2 Supercritical coal-fired power plant

The power plant used to reflect the characteristics of the flue gas and the heat source is described with three levels of detail. Level 1 is the real plant data of the reference plant, the

state-of-the-art, pulverized fuel (PF)-fired *Nordjyllandsvaerket* in Denmark. Level 2 is a detailed steady-state model of the reference plant, which has been validated against real plant data under full-load conditions and various part-load conditions [93]. The Level 2 description of the power plant is applied in **Paper III** to evaluate the steady-state performance of the reference power plant under full-load and part-load conditions when operating with CO₂ absorption. Level 3 is a simplified version of the reference plant that is primarily used for the dynamic simulation outlined in **Paper IV**. The simplified power plant is a typical representation of a modern power plant operated in Europe, including a supercritical steam cycle, single-reheat, PF-fired plant. The power plant model incorporates the main aspects of state-of-the-art PF power plants that are of importance for the dynamic characteristics, such as sliding-pressure operation, steam reheating, multiple-stage turbines, as well as a feed-water heating system and an outlet temperature control for live and reheat steam. A major feature of the state-of-the-art PF power plants is their high electrical efficiency, generally in the range of 42%–47%, when operated under design conditions. The simplified version of the model is initially constructed in steady-state mode to provide plant performance design data under full-load and part-load conditions. The dynamic power plant model mainly comprises components from Modelon's Thermal Power Library [94]. The main modeling assumptions made to describe the dynamic power plant boiler, steam cycle, flue gas pathway, and control structure are presented in **Paper IV**. Design data from the reference power plant [93] are used to dimension several of the modeled components.

In **Papers III** and **IV**, two modes of typical load changes in a coal-fired power plant are investigated, as listed in Section 2.3.2. The first mode of operation considers how the capture process responds to a change in power plant load, i.e., when the fuel input to the power plant is adjusted for a change in electricity demand. This may, for example, occur as a consequence of variations in the levels of electricity generation from intermittent renewable energy sources, such as wind power. The second mode of operation considers variations in the availability of steam for the CO₂ capture process. As an example, this may represent a period of time of high demand and low electricity generation from intermittent renewable energy sources and, thereby, a high price for electricity. In the evaluation of varying load conditions, the connection to the CO₂ transportation system is treated as a boundary condition in the dynamic capture process model and is not assumed to impose any restrictions on the flow conditions during transient operation.

3.2.1 Integration of CO₂ absorption with the power plant

The model of the fully integrated CO₂-absorption-power plant system is shown in Figure 3.3. The steam required for solvent regeneration is extracted from the IP/LP section of the turbine through a throttled LP turbine retrofit, similar to that presented by Sanchez Fernandez et al. [95], Liebenthal et al. [96], and Lucquiaud and Gibbins [97]. This approach makes the LP section of the turbine over-dimensioned for the integrated system, which operates with a 90% CO₂ capture rate under full-load conditions. The steam extraction to the reboiler is throttled to maintain the extraction pressure and, thereby, a suitable condensation temperature in the reboiler across the whole range of power plant loads. It is important to control the reboiler temperature to avoid thermal degradation of the solvent. The extracted steam is de-superheated

to 140°C, which is just above the saturation temperature at the extraction pressure of 3 bar, using evaporative spray cooling with the feed-water slipstream downstream of the condenser. The condensate from the reboiler is returned to the feed-water loop by pumping it into the deaerator. The flue gas that exits the conventional flue gas cleaning system (FGD in Figure 3.3) is conditioned in a direct contact cooler, so as to cool the flue gas to 40°C and remove the condensed water before it enters the absorber.

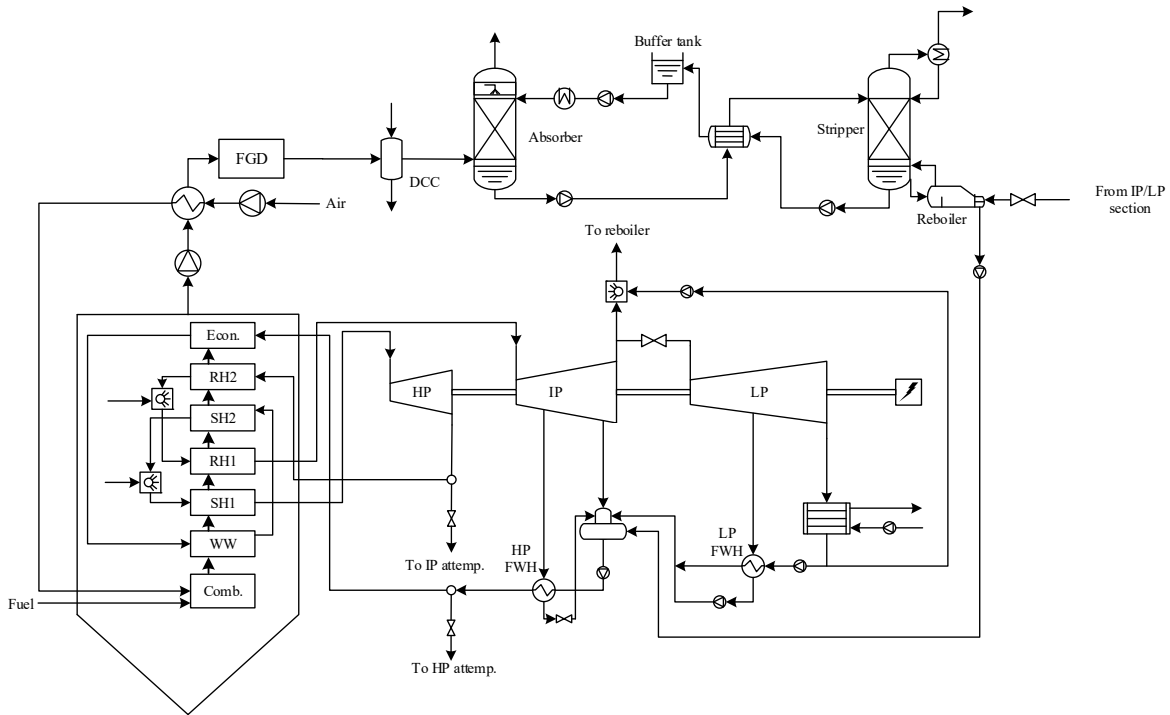

Figure 3.3: Process schematic of the connections between the steam cycle and the CO₂-absorption process with a throttled LP turbine configuration used for steam extraction. Source: Paper IV.

3.2.2 Control of CO₂ absorption integrated in a power plant

Figure 3.4 presents a schematic of the MEA-based CO₂-absorption process, including the measurement points for control variables and flow manipulators, as modeled in **Paper IV**. The identified degrees of freedom (DoFs) in the system are the five flow manipulators (pumps and valves), designated as FC1–FC5. The CO₂-absorption process control system is divided into a regulatory layer and a higher-level control layer. The regulatory layer controls the liquid levels in the system to achieve a consistent inventory, which is crucial for process stability [98]. The available control variables (CVs) in the regulatory layer are the absorber, stripper, and buffer tank level, as well as the make-up water stream. To ensure stable inventory control, the buffer tank level is allowed to fluctuate freely. Perfect control of the make-up water stream to the buffer tank is assumed in the model. The remaining two CVs in the regulatory control layers are the absorber and the stripper liquid levels, which are to be paired with one DoF each. It should also be pointed out that the condensate level on the steam side of the reboiler (i.e., on the steam cycle side) is regulated as part of the regulatory control layer of the integrated power plant and CO₂ capture process system.

Three of the five DoFs identified in Figure 3.4 are designated as regulatory control variables. The higher-level control layer, which consists of the remaining two DoFs, regulates the CVs that are identified as being important for the CO₂-absorption process. In addition, three additional CVs are assumed to be perfectly controlled, which means that they are not included in either the regulatory layer or the higher-level control layer. These CVs include a perfect back-pressure regulator, to keep the pressure constant at the top of the stripper, and ideal temperature controllers in the solvent cooler and the cooling condenser. The stripper outlet pressure assumption replaces the CO₂ compressor, which is omitted from the model.

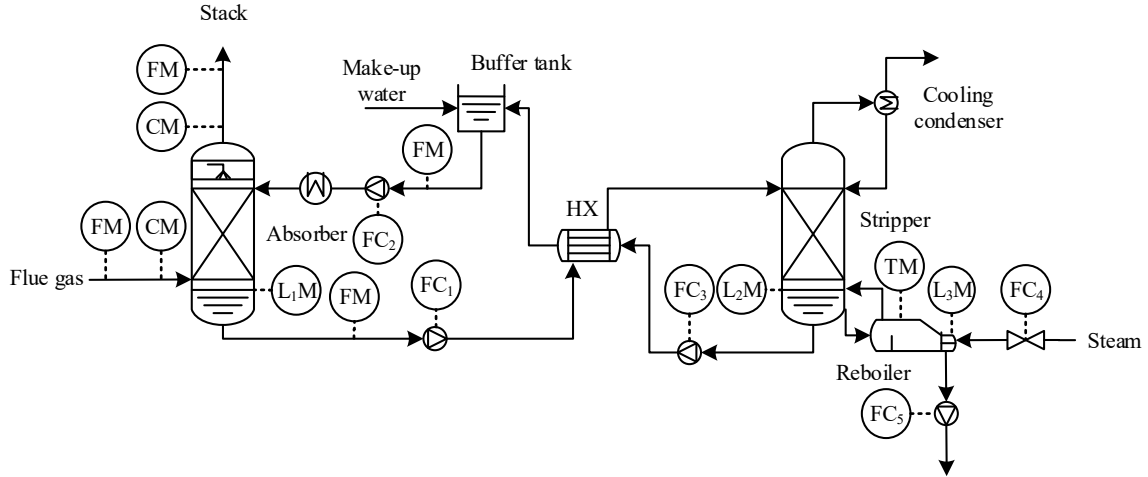

Figure 3.4: Schematic overview of the CO₂-absorption model. Controllers (C) and measurement points (M) for pressure (P), flow (F), temperature (T), gas composition (C), and liquid level (L) are indicated in the figure. Source: Paper IV.

3.2.3 Comparison of approaches in dynamic modeling of CO₂ absorption

As discussed in Section 2.3.2, there are two common approaches to handling the interconnections, i.e., the steam cycle and the flue gas path, between the power plant and the CO₂-absorption process. In both approaches, closed loop controllers are implemented to control important design variables during load changes in the power plant. The approach applied in **Paper III** considers connections to the power plant as boundary conditions. In **Paper IV**, the applied approach includes direct connections between dynamic process models of the CO₂ absorption process and the power plant. In addition to the fully integrated approach, several refinements are made to the CO₂ absorption model compared with **Paper III**, including the introduction of transport delay in the lean-rich solvent heat exchanger, installation of a buffer tank upstream of the absorber, and control of the condensate level on the steam side of the reboiler. In addition, the liquid levels in the column sumps are no longer considered to be perfectly controlled. Furthermore, the CO₂ absorption process dimensions are adapted from a steady-state design carried out in the Aspen Plus software, and the residence times in various parts of the process are adapted from the recent work of Flø et al. [74], [99].

The difference between the two modeling approaches applied in this thesis is exemplified in Figure 3.5, which shows the response from the CO₂ absorption model in **Paper III** and **Paper IV** in steam flow to the reboiler. The representation of the steam cycle as a boundary condition without constraints on the steam flow (**Paper III**) results in considerably faster responses

compared to a fully integrated model (**Paper IV**). A considerably longer time is needed to reach a new steady state in the steam flow with the integrated model (to reach $\pm 5\%$ of the new steady-state value takes around 60 minutes, as compared to 8 minutes for the stand-alone CO₂ absorption model). This clearly shows the importance of accounting for the interactions between the CO₂ absorption plant and the power plant.

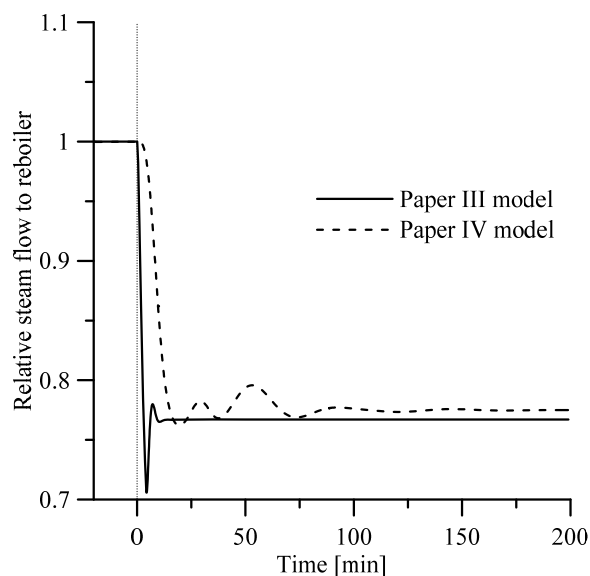

Figure 3.5: Responses in terms of steam flow to the reboiler to a reduction in the power plant load from 100% to 80%. Comparison of a dynamic CO₂ absorption model with a steam cycle that is represented by a boundary condition (Paper III) and a fully integrated model (Paper IV). The vertical dashed line indicates the time-point at which the load change starts.

3.3 Evaluation from an energy systems perspective

3.3.1 Cost of CO₂ absorption

Cost estimations have been applied in **Paper II**. The capital cost (CAPEX) required for implementation of the MEA-based absorption process is assessed with a detailed individual factor estimation method [100]. The cost is estimated from equipment lists derived from the process modeling described in Section 3.1.1 (see **Paper II** for the detailed equipment list). The equipment cost for each individual component is derived from the Aspen In-Plant Cost Estimator tool, and is adjusted with a cost escalation factor for each individual component to account for the installation cost. The cost factors reflect the type and size of the specific equipment, as well as the characteristics of the site in which the plant is built, and are calculated from empirical equations derived from numerous industrial project cost data that have been compiled in an in-house database. If all the equipment components are identified, an investment estimate based on the detailed factor estimation method normally has an uncertainty of $\pm 40\%$ (80% confidence interval). A contingency factor (20%) is included in the CAPEX. All the cost data are reported in €_{2015} . It is assumed that the CO₂ capture plant that is built is the *n*th of its kind (i.e., the technology is mature), and that the capture plant is treated as an extension of the existing industrial plant.

Operating expenditures (OPEX), which are dominated by the cost of heat supply for solvent regeneration but also include other utilities, maintenance, and labor, are evaluated for two

emission sources with similar volume flows but different CO₂ contents, so as to exemplify the effects of OPEX on the total CO₂ capture cost and its sensitivity to economic assumptions. For simplification, all utility costs are strictly considered as utility that is provided by surrounding systems, generating an operating cost for the capture plant. This is common practice, as utilities are highly integrated with other processes and a direct allocation of investment cost is difficult. The economic assumptions required to estimate the total CO₂ capture cost are presented in Table 3.1. The price of electricity is assumed to be in the upper range of the Platts-Pan-European Power Index, representing an electricity price benchmark in Europe, for the period 2010–2015 [101]. The cost of steam is assumed to 30% of the electricity price, while the cost of cooling water represents the cost of cooling with seawater, based on industrial experience.

Table 3.1: Economic assumptions made for estimations of the CO₂ capture cost.

Project lifetime	25 years
Construction time	3 years
Operation time	22 years
Interest rate	7.5%
Annualized maintenance cost	4% of investment cost
Annual labor cost (engineers and operators)	821 k€/year
<hr/>	
Cost of utilities	
Electricity	55 €/MWh
Steam	17 €/t
Cooling water	0.02 €/m ³

A regional case study of CO₂ capture from the process industry

An evaluation of the investment required to apply CO₂ capture to large-scale industrial sources is conducted in a case study of Sweden, as an example of a present-day, highly industrialized region with relative proximity to large and well-documented CO₂ storage sites. The study is limited to facilities with emissions of >500 ktCO₂ per annum, as they account for a large share of the industrial CO₂ emissions in Sweden (>50% of the fossil-related emissions in fact) and as sufficient scale is crucial to the feasibility of CCS (see **Paper II** for a list of the facilities and their annual CO₂ emissions). Industry-specific characteristics of importance to carbon capture, i.e., number of stacks, volume flows, and gas composition, are considered in the evaluation. A map illustrating the prerequisites for CCS in Sweden is presented in Figure 3.6, and it includes the geographic locations of the large point sources of CO₂, as well as possible transport hubs ([102]) and CO₂ storage locations [103, 104]. It should be noted that none of the large point sources belong to the power sector. Most of the emission sources are pulp mills, with their emissions being primarily of biogenic origin. Other notable large-scale sources are oil refineries, steel mills, cement plants, and chemical plants.

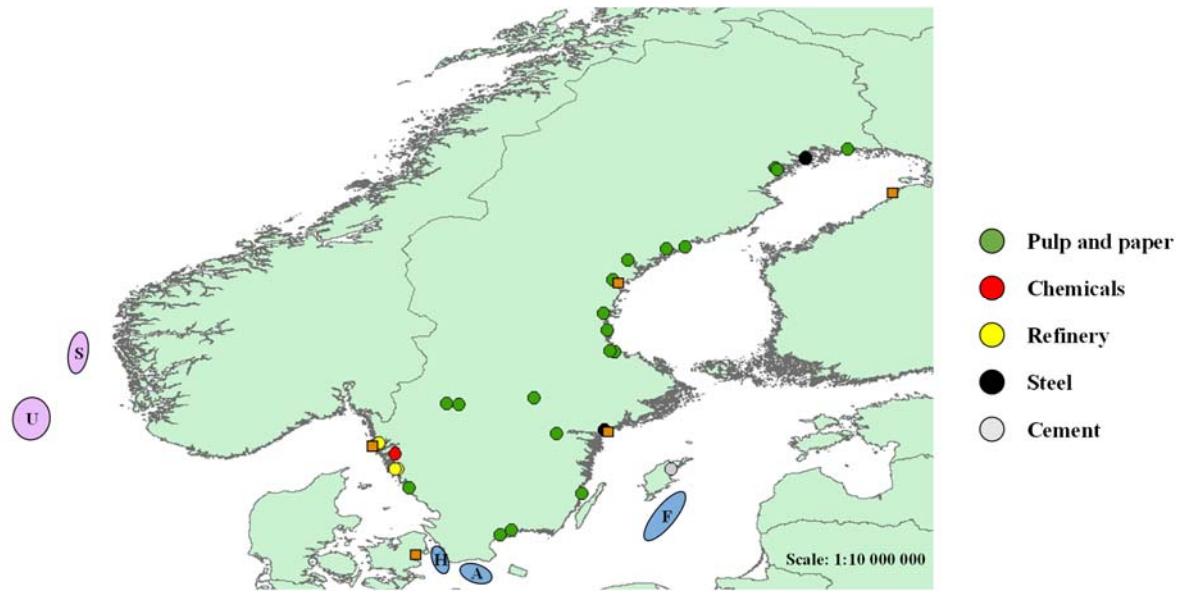

Figure 3.6: Geographic overview of Swedish emission sources (>500 ktCO₂ per annum). The blue ellipses indicate three possible storage sites in Swedish territory: Höganäs-Rya (H), Arnage Greensand (A), and Faludden (F). The purple ellipses indicate two possible storage sites within Norwegian territory: the developed site Utsira (U) (southern part of the formation), and the Smeaheia (S) field. The orange rectangles indicate the CO₂ transport hubs proposed by Kjærstad et al. [102].

3.3.2 Thermal power in future electricity systems

Paper V explores the conditions for thermal power generation, with and without CO₂ capture, in future electricity systems through the application of a cost-minimizing investment model developed by Göransson et al. [59]. The linear optimization model minimizes the total cost of the electricity system, considering investments and costs for operation, including cycling, in power generation based on the assumed level of demand over the time period considered. A timeframe of 1 year is modeled with a time resolution of 3 hours. Therefore, flexibility in a shorter time frame, such as the primary frequency response, is not considered in the model. Furthermore, the model does not take into consideration power trading and interconnections with neighboring regions, and it assumes perfect transmission within the region. The model uses a green-field approach, i.e., no existing capacity is considered.

As applied here, the model considers three isolated energy systems, which differ with respect to the conditions for wind and solar power deployment, as well as the size in terms of total demand. The characteristics of the investigated energy systems are established using a corresponding geographic region that provides input data to the investment model (in the form of demand profile, wind and solar data, as well as local reserves of biomass and lignite resources). The main characteristics are listed in Table 3.2.

Table 3.2: Characteristics of the investigated electricity generation systems with respect to wind and solar conditions and the corresponding geographic regions used for the input data. Source: Paper V.

Region no.	Yearly demand (TWh)	Wind conditions	Solar conditions	Geographic basis	Nuclear investments	Local lignite reserves
1	29.3	Favorable	Less favorable	Ireland	No	No
2	82.6	Moderate	Favorable	Central Spain	Yes	Yes
3	40.3	Less favorable	Less favorable	Hungary	Yes	Yes

The model is applied for Year 2050. This choice of year mainly affects the costs for various technologies, assumptions made regarding efficiency improvements, and the commercial availability of technologies equipped with CCS. For technical specifications of all the generation technologies included in the investment model, see **Paper V**.

Interviews with industry experts

In **Paper V**, the literature on measures to improve thermal power flexibility is reviewed, to provide inputs with respect to flexibility parameters and associated costs for the energy system case study described previously. The focus is on those parameters that are relevant to the energy system model applied in this study, i.e., minimum load, part-load efficiency, start-up times and emissions, and CO₂ capture. In addition to the scientific and grey literature review on technical aspects of power plant flexibility, important trends are identified through interviews with eight individual experts who have longstanding experience in the field of thermal power plant research and operation. Table 3.3 lists the areas of expertise and the type of associated company for each expert. The experts were selected from the contact network of the authors, i.e., no systematic screening of experts was carried out.

Table 3.3: Experts who provided information for this work, their fields of expertise, and types of associated companies. Source: Paper V.

Expert #	Area of expertise	Type of company
#1	Firing systems and boiler design	Technology provider
#2	Power plant design and electricity markets	Utilities
#3	Steam turbine operation	Energy consultant
#4	Design and dynamics of thermal systems	Technology provider
#5	Plant control and optimization	Energy consultant
#6	Plant control and optimization	Energy consultant
#7	Plant control and optimization	Energy consultant
#8	Regulating power and frequency control	Energy consultant

4 Results

In this chapter, the results from the work are presented in line with the three research objectives of the thesis presented in Section 1.1.

4.1 Effects of CO₂ source characteristics on the CO₂ absorption process

4.1.1 Technical performance

The effects of a wide range of flue gas CO₂ concentrations (1–40 mol%) on the steady-state performance of the CO₂ absorption process were investigated. Figure 4.1a shows the specific heat requirements of the MEA and ammonia-based absorption processes for the range of CO₂ concentrations considered. Also shown in the figure are examples of the CO₂ concentrations in industrial processes investigated in the present work. The analysis performed in **Paper I** reveals that the temperature in the absorber increases with increasing CO₂ concentration in the flue gas, and that the absorber temperature strongly influences the MEA-based absorption process. At concentrations >20mol%, the process performance is degraded due to this effect (*cf.* Figure 4.1a). In contrast to the MEA-based process, the heat requirement of the ammonia-based process decreased continuously over the entire range of CO₂ concentrations investigated. Compared to MEA, ammonia is used at much lower concentrations, and it can be regarded as a solvent that has a relatively low heat of reaction and low reactivity. These characteristics all affect the process performance depicted in Figure 4.1a.

The differences between the bulk and equilibrium partial pressures of CO₂ in the MEA-based absorber are shown in Figure 4.1b. The operating conditions in the absorber bring the concentrations close to equilibrium conditions in the bottom of the column (*cf.* Figure 4.1b). Modifying the shape of the temperature profile by applying intercooling to the lower part of the absorber improved the process performance at CO₂ concentrations in the range of 20–40mol%. In Figure 4.1b, the effect of the intercooling temperature on the difference between the bulk and equilibrium partial pressure of CO₂ is also shown. The optimal position of the intercooler shifts towards the top of the absorber with increasing intercooler temperatures. Thus, the optimal temperature conditions of the absorber vary throughout the column, with decreasing temperatures towards the bottom of the column, where a high temperature approaches the equilibrium limitations for absorption at high CO₂-loadings.

The effects of intercooling on the specific heat requirement of MEA-based absorption are illustrated in Figure 4.1a. At lower concentrations of CO₂, the effects of intercooling are negligible, so the three lines that indicate the heat requirements of the MEA-based process under adiabatic and intercooled conditions coincide at concentrations of <10mol%. The absorber intercooling becomes more effective at reducing the specific heat requirement with

increasing concentrations of CO₂, e.g., intercooling to 50°C leads to specific heat requirement decreases of 4.2% and 9.3% for CO₂ concentrations of 30mol% and 40mol%, respectively.

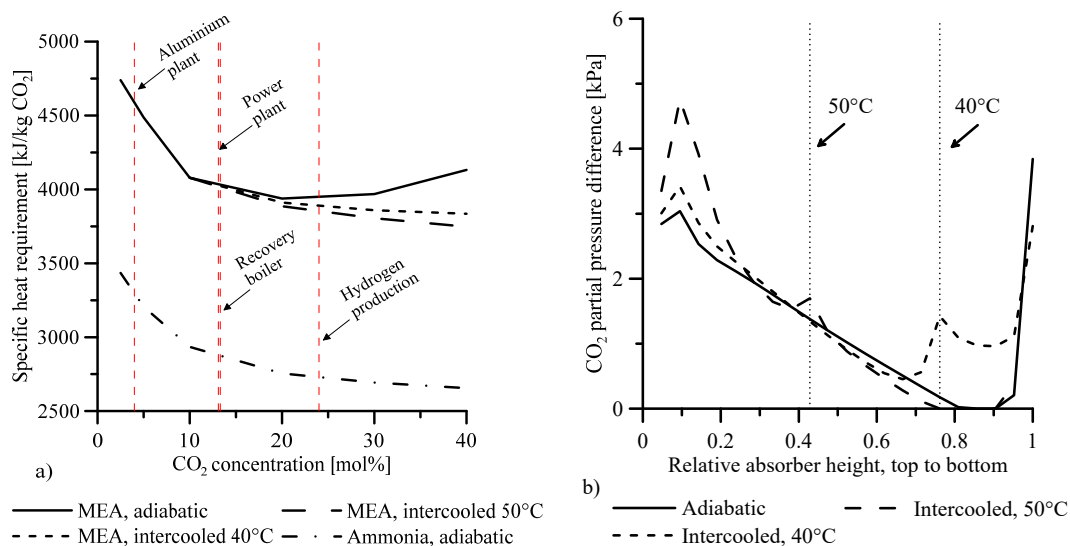

Figure 4.1: a) Specific heat requirements of MEA-based and ammonia-based absorption systems for 2.5–40mol% CO₂ in the flue gas with a 90% CO₂-capture rate in adiabatic (solid and dashed-dot lines) and intercooled (dashed lines) columns. The red vertical lines indicate the CO₂ concentrations of important emissions-intensive industrial processes. b) Differences between the bulk and equilibrium partial pressures of CO₂ in the MEA-based absorber under adiabatic and intercooled conditions with a flue gas CO₂ concentration of 30 mol% and a CO₂-capture rate of 90%. The vertical lines indicate the optimal locations of the intercooler for the specific heat requirements. The data presented in Figure 4.1a are based on the simulations carried out in Paper I. Source for Figure 4.1b: Paper I.

4.1.2 Investment costs

The investments required (CAPEX values) for an MEA-based CO₂ absorption process designed for 90% CO₂ capture are given in Figure 4.2, for two industrial emission sources with similar flue gas flows but with significantly different concentrations of CO₂. The costs are presented on a component level for all the process units. The CO₂ concentration in the flue gas strongly affects the investment cost, which amounts to 214 M€ for the CO₂-rich source (with 30 vol% CO₂) and 136 M€ for the CO₂-lean source (with 13 vol% CO₂). A higher investment is required for the CO₂-rich source in capital-intensive process components, such as the solvent heat exchanger (HX-2), the stripper reboiler (HX-4), the cooling water pump (P-7), and the compressor, due to the larger amount of CO₂ captured (1615 kt/a vs. 682 kt/a) and the higher flow of solvent needed. In accordance with Figure 4.1 (**Paper I**), an absorber intercooler is included for the CO₂-rich source. The investment required for the intercooler increases only marginally the total investment and is motivated by the energy savings made.

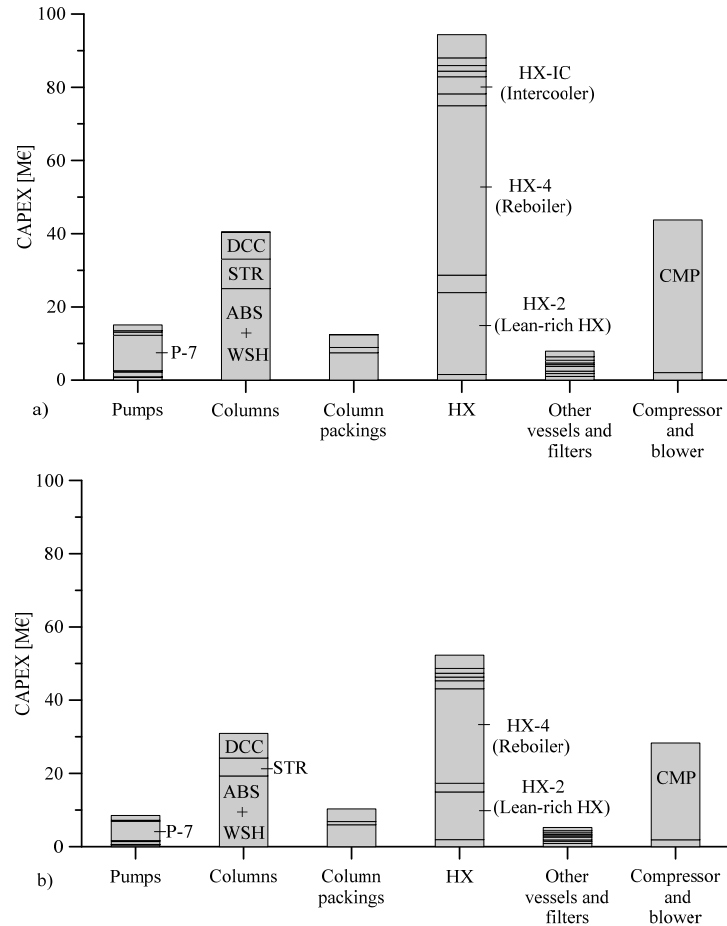

Figure 4.2: Estimated CAPEX values for the units of the absorption process listed in the equipment list presented in Paper II (in M€) for: a) a steel mill's power plant with a flue gas flow of 136.5 Nm³/s and a flue gas CO₂ concentration of 30 vol%; and b) a pulp mill's recovery boiler with a flue gas flow of 133 Nm³/s and a flue gas CO₂ concentration of 13 vol%. Source: Paper II.

The specific CO₂-capture costs (€/tCO₂ captured), including OPEX, for the two emission sources are shown in Figure 4.3. The specific cost for the CO₂-richer source is considerably lower, due to the high CO₂ content of the flue gas and, consequently, the larger amount of CO₂ captured. As expected, the most significant difference is seen in the fixed costs, i.e., the investment, maintenance, and labor costs, which are roughly 50% higher for the CO₂-lean source, while the utility cost is roughly 12% higher for the CO₂-lean source. The cost for steam represents the largest share of the total cost for both sources. The steam cost depends heavily on the conditions used for process integration at the specific site, as well as the time-dependent market conditions (seasons, hour of the day, and weather conditions), which affect fuel prices, the cost of electricity, and the cost of district heating.

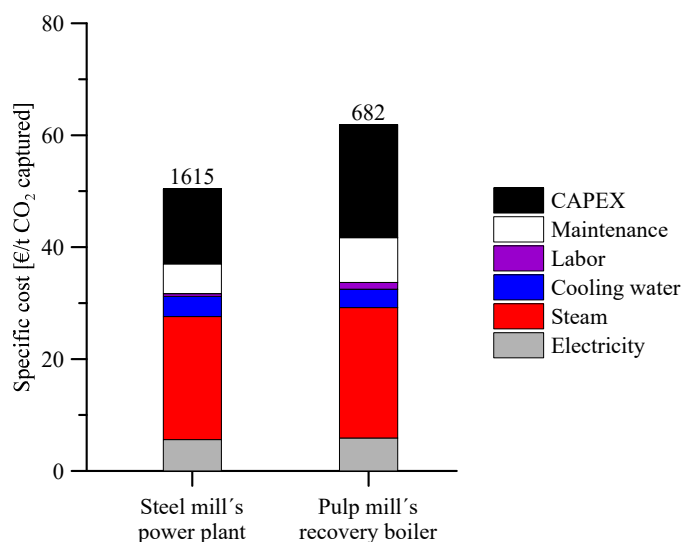

Figure 4.3: CO₂-capture costs (in €/tCO₂ captured) for a steel mill power plant with a flue gas flow of 136.5 Nm³/s and a flue gas CO₂ concentration of 30 vol%, and a pulp mill recovery boiler with a flue gas flow of 133 Nm³/s and a flue gas CO₂ concentration of 13 vol%. The amount of CO₂ captured annually (in kt) is presented in numbers above the bars. The CO₂-capture cost includes the OPEX, which is based on the economic assumptions listed in Table 3.1. Adapted from Table 6 in Paper II.

Assessing the investment costs and CO₂ reduction potential for the process industry – a case study of large-scale emission sources in Sweden

The investment required to implement CO₂ capture at industrial CO₂ sources with emissions >500 ktCO₂ per annum is illustrated through a case study of all the large point sources in Sweden (see **Paper II** for a list of the facilities included in the case study and their associated annual emissions of CO₂). The results from this case study are presented in Figure 4.4, as the specific CAPEX per tonne of CO₂ captured for the industrial sources and as the cumulative investment required as a function of the system capacity in annual reduction of CO₂. All the emission sources in the Swedish system pertain to the process industry and are predominantly pulp mills with carbon emissions that are primarily of biogenic origin. Other large sources include oil refineries, steel mills, cement plants, and chemical plants. The differences in cost between these sources are considerable. As shown in Figure 4.4a, the specific CAPEX decreases drastically as the size of the CO₂ source increases, illustrating the importance of economy of scale. The lowest specific CAPEX value in the system is found for the recovery boilers of large pulp mills, various emission sources in steel mills, and a cement plant. However, these sources do have the highest absolute investment costs due to their size. The converse (high specific but low absolute CAPEX) is found for the relatively small lime kilns in the many pulp mills in Sweden.

The relatively high number of pulp mills located around Sweden, and consequently, the high levels of biomass-related carbon emissions, together create a significant potential for implementing BECCS. The CO₂ reduction potential from the recovery boilers of the pulp mills alone amounts to 13.6 Mt/a (for a total investment of 2,600 M€). In comparison, Sweden's total fossil-based CO₂ emissions in 2016 (including transport) amounted to 53.6 MtCO₂ equivalent, of which the total fossil-based emissions from the industrial and power & heat sectors accounted for 17.2 MtCO₂ [105].

The economic calculations performed in this work focus on investments in CO₂-absorption processes for the various emission sources. In addition, costs for transport infrastructure is estimated based on previous work within the NORDICCS project [102]. Figure 4.4b relates the capture-side investment to the required investments in transport infrastructure for the Nordic region. The selected transport solution is based on the five hubs for ship transport suggested by Kjärstad et al. [102], who showed that ship transport was more suitable for most emission sources in the Nordic region than transport by pipelines. During the ramp-up phase, the relative share of the investment required for transport infrastructure is significant and on a similar level as the investment needed for the CO₂-capture plants. However, in an established system, the required investment levels off with increased co-utilization in infrastructure, and becomes small in relation to cumulative investments in CO₂-capture plants. This emphasizes the importance of effective policy instruments that stimulate investments in transport infrastructure during the ramp-up phase, and also underlines that the required investment in capture plants for large-scale CO₂ mitigation through CCS in Sweden is significantly larger than the required investment in transport infrastructure.

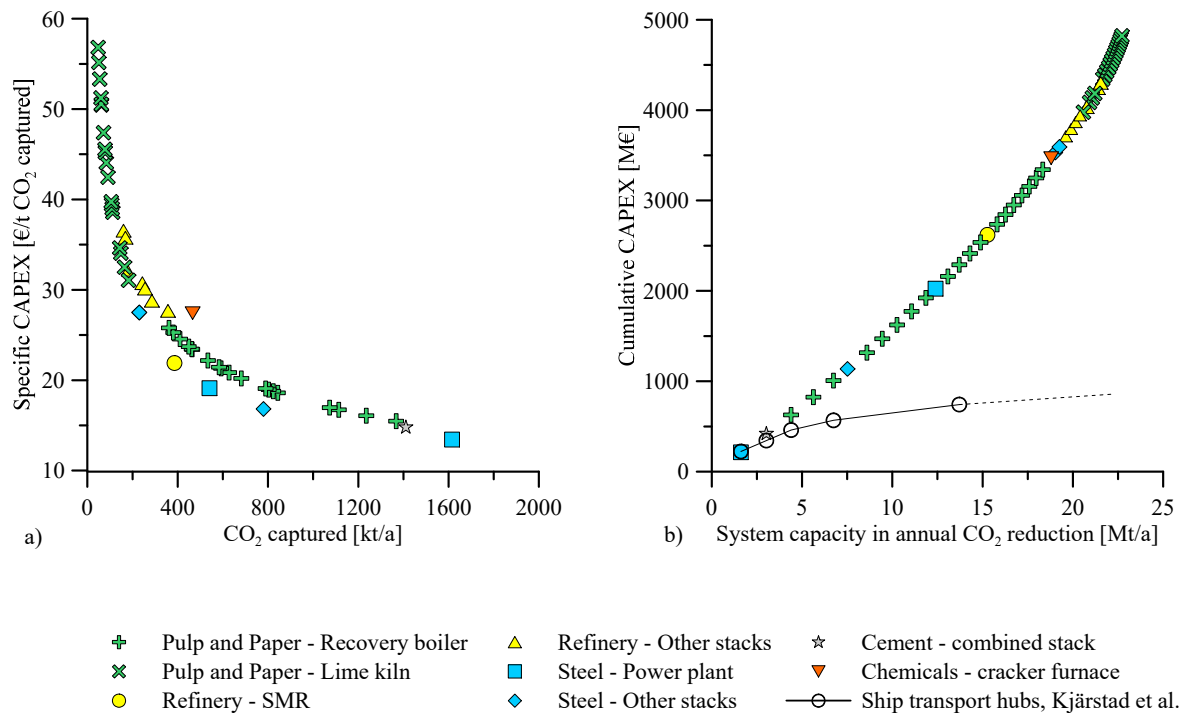

Figure 4.4: Capital cost estimations for all point sources of CO₂ in Sweden that have yearly emissions >500 ktCO₂ (see Paper II for a list of sources included in the study and their associated emissions). a) Specific cost (€/tCO₂) as a function of the amount of CO₂ captured from each source. b) Cumulative investment in CO₂ capture (M€) and ship transportation as a function of the system capacity in annual reduction in CO₂, with sources sorted in order of specific CAPEX. Adapted from Figure 5 and Figure 8 in Paper II.

4.2 Operation of a CO₂ absorption process integrated into a coal-fired power plant

The operation of the MEA-based CO₂ absorption process integrated with a supercritical coal-fired plant was studied for two operative scenarios (varying the power plant load and varying the availability of steam for the CO₂-absorption process). This yielded three cases to which several control schemes for the CO₂-absorption process were applied. Figure 4.5 gives an overview of the cases investigated. An overview of the applied control schemes is presented in Table 4.1, and includes the pairing of higher level CVs with flow manipulators, as referred to in Figure 3.4.

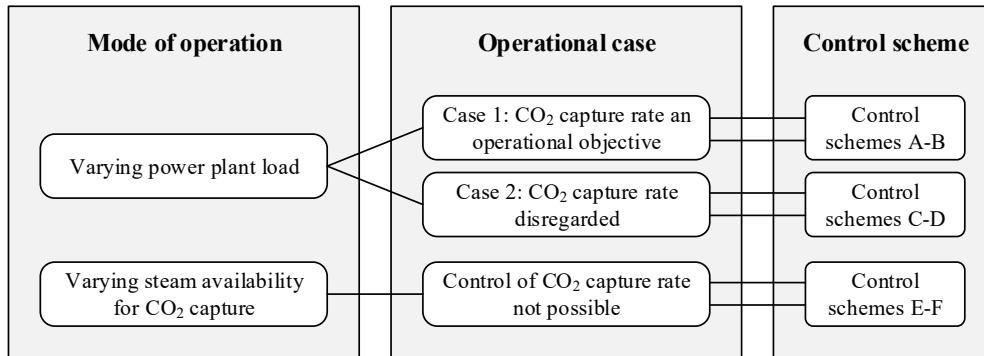

Figure 4.5: Investigated modes of operation, subsequent operational cases, and control schemes. Source: Paper IV.

Table 4.1: Overview of the control schemes applied in Paper IV for the CO₂ absorption process when integrated with a supercritical coal-fired power plant.

Mode of operation	Operational case – Control scheme	Scheme description, paired variables for higher-level control objectives	References
Varying power plant load	Case 1: Scheme A	<ul style="list-style-type: none"> Reboiler temperature – Steam flow rate (FC₄) CO₂-capture rate – Solvent flow upstream of absorber (FC₂) 	[80, 86, 106, 107]
	Case 1: Scheme B	<ul style="list-style-type: none"> Reboiler temperature – Solvent flow downstream of absorber (FC₁) CO₂-capture rate – Steam flow rate (FC₄) 	[78]
	Case 2: Scheme C	<ul style="list-style-type: none"> Reboiler temperature – Steam flow rate (FC₄) L/G ratio – Solvent flow upstream of absorber (FC₂) 	[108]
	Case 2: Scheme D	<ul style="list-style-type: none"> Reboiler temperature – Steam flow rate (FC₄) Constant solvent flow rate (FC₂) 	-
Varying steam availability for CO ₂ capture	Scheme E	<ul style="list-style-type: none"> L/G ratio – Solvent flow upstream of absorber (FC₂) 	[109]
	Scheme F	<ul style="list-style-type: none"> Reboiler temperature – Solvent flow downstream of absorber (FC₁) 	[109]

4.2.1 Varying power plant load

In this mode of operation, the power plant load was ramped back and forth between 90% load and 70% load at a ramp rate of 4%/min, which corresponds to the rate commonly used in modern power plants [60]. Two operational objectives are considered with two control schemes applied to each of the two objectives (*cf.* Figure 4.5). In *Case 1*, the CO₂-capture rate is an operational objective, while in *Case 2*, the CO₂-capture rate is disregarded as an operational

objective. Figure 4.6 shows the simulated responses of the power output in the power plant with and without CO₂ absorption. The simulated responses of the generated power, the steam flow to reboiler, the CO₂-capture rate, and the specific heat requirement in the integrated system operating with different control schemes are presented in Figure 4.7 and Figure 4.8, for *Case 1* and *Case 2*, respectively. The calculated settling times for these performance indicators are shown in Table 4.2.

Comparison of power plants with and without CO₂ absorption

A comparison of the responses to a load profile from a power plant with or without CO₂ absorption is illustrated in Figure 4.6. The responses and settling times (6–9 minutes) of the power output from the two systems are similar. This is also true for control Schemes C and D. A considerably longer settling time is required for the CO₂-absorption process (1.0–1.5 hours for a 95% settling time) than for the power plant. For most of the parameters and control schemes applied, the settling time is similar, regardless of whether the power plant load is ramped up or down, although some differences are observed between ramping up and down, illustrating the non-linearity of the system.

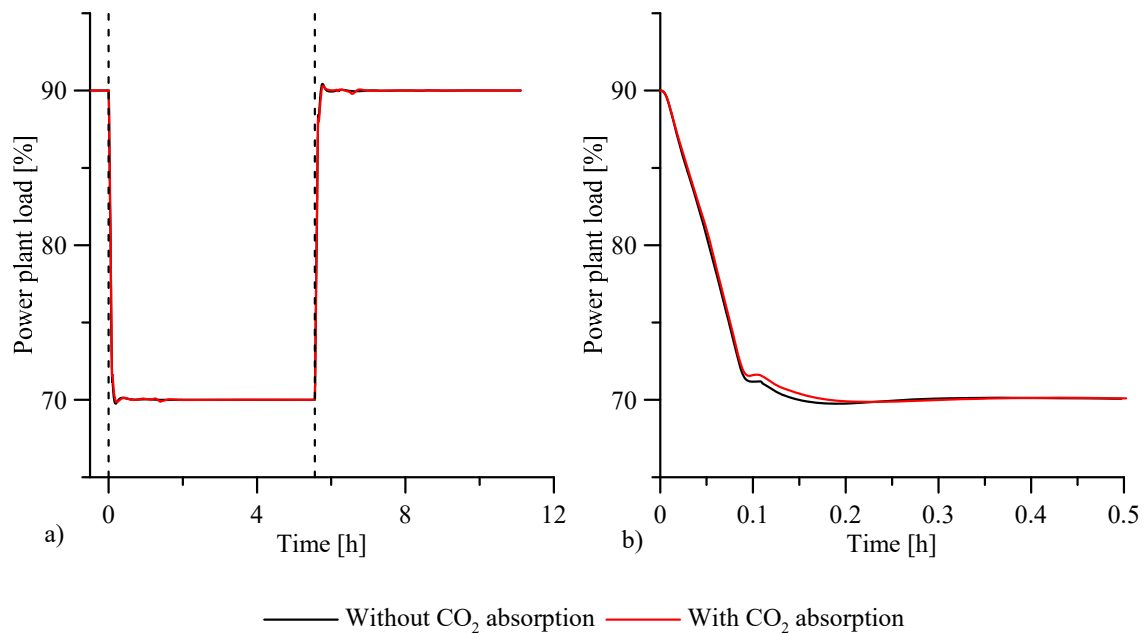

Figure 4.6: Simulated power output responses of a power plant without CO₂ absorption and of a power plant with CO₂ absorption operating with control Scheme A (cf. Figure 4.5 and Table 4.1) for: a) load profile of 90%–70%–90%; and b) a 90% to 70% load change in a shorter time-scale. Each vertical dashed line indicates the start of a load change.

Comparison of operational objectives for the CO₂ absorption process

Two operational objectives were investigated for the integrated system operating with a varying power plant load: (i) considering and (ii) disregarding the CO₂-capture rate as a control variable. Table 4.2 compares the influences of the operational objectives on the system response. A slower response is observed in the integrated system when the CO₂-capture rate is maintained during the load change (cf. *Case 1* vs. *Case 2*). In *Case 2*, both control schemes

keep the reboiler temperature tightly controlled with the steam flow rate of the reboiler. Neither scheme contains a feedback control loop of solvent recirculation for the higher-level control objectives. Therefore, the power output stabilizes faster in *Case 2* than in *Case 1*. The relatively high solvent flow rate in both control schemes results in *Case 2* having a CO₂-capture rate >90%. This requires a higher level of steam in the reboiler to maintain the set temperature, as compared with *Case 1* (*cf.* Figure 4.7b and Figure 4.8b). This leads to a relatively high heat requirement for solvent regeneration (*cf.* Figure 4.8d), especially with Scheme D, in which the solvent flow rate is high.

Table 4.2: Settling times (95%) of selected performance indicators in relation to power plant load variation. The settling time for the CO₂-capture rate is not shown for *Case 1* (Schemes A and B), as it is a control variable in this case, and the settling time for the solvent circulation rate is not shown for Scheme D, as it is kept constant. Adapted from Table 8 and Table 9 in Paper IV.

Performance indicator	Case – scheme	Settling time, 95% (min)	
		Ramp-down, 90% to 70%	Ramp-up, 70% to 90%
Generated power	Power plant without CO ₂ absorption	6.7	7.9
	1 – A	7.3	8.9
	1 – B	40.8	23.5
	2 – C	7.4	8.5
	2 – D	6.9	7.7
Steam flow to reboiler	1 – A	64.2	62.2
	1 – B	95.1	122.9
	2 – C	59.0	64.5
	2 – D	74.5	87.7
CO ₂ -capture rate	1 – A	-	-
	1 – B	-	-
	2 – C	60.0	54.9
	2 – D	72.4	59.2
Solvent circulation rate	1 – A	57.5	57.9
	1 – B	113.3	136.4
	2 – C	55.0	57.8
	2 – D	-	-

Comparing the two control schemes of *Case 1*, Scheme A shows superior dynamic performance, as evidenced by the system response in Figure 4.7. The two relatively fast, higher-level control loops in Scheme A result in rapid responses, although sharp overshoots are also observed during ramping for some of the manipulated variables, such as the steam flow to the reboiler (Figure 4.7b). In Scheme B, the CO₂-capture rate is controlled by the steam flow rate to the reboiler, resulting in a time delay between the two variables and a slowly fluctuating adjustment of the CO₂-capture rate to the set value of 90% (*cf.* Figure 4.7c). Therefore, the specific heat requirement also adjusts slowly, fluctuating in the same manner as the steam flow rate to the reboiler in Scheme B (*cf.* Figure 4.7d).

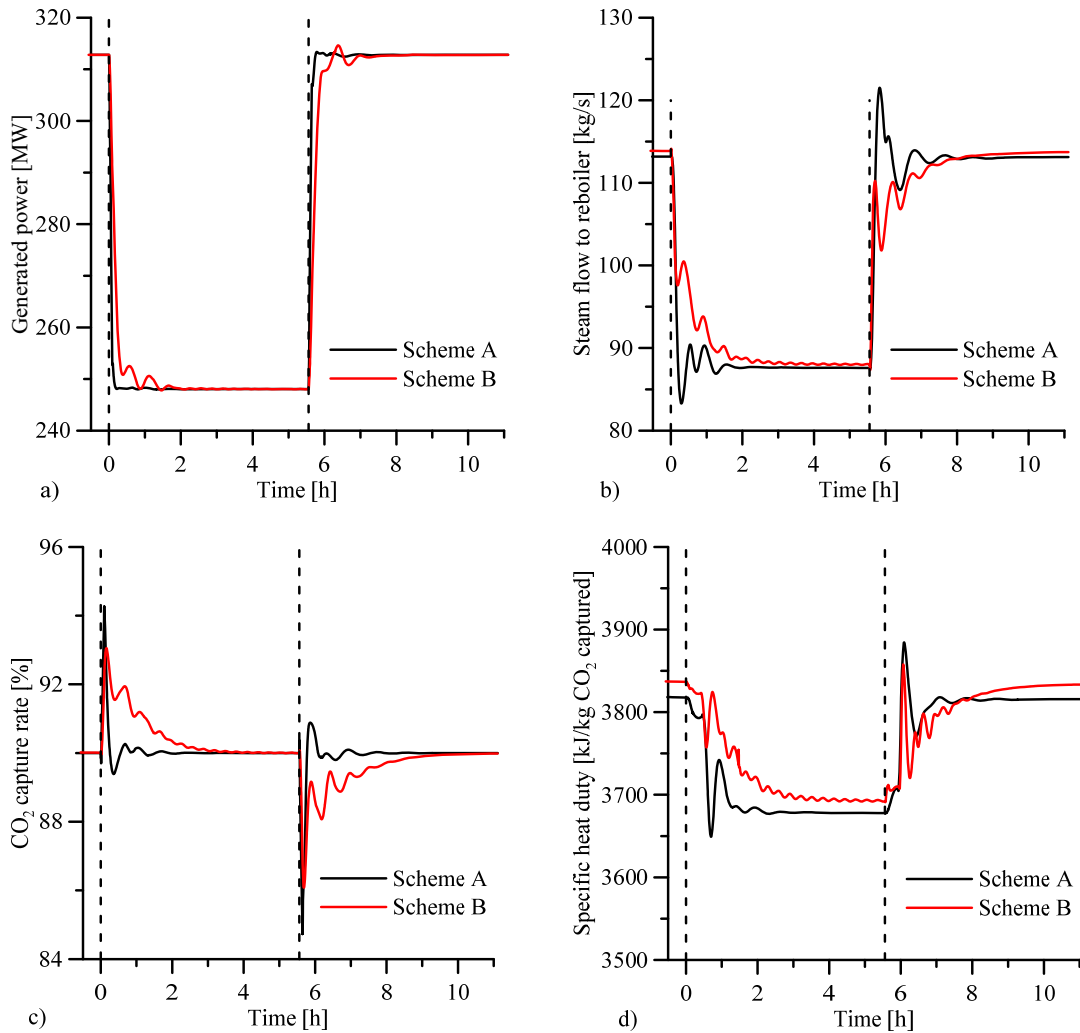

Figure 4.7: Responses in a power plant with CO₂ absorption for a load profile of 90%–70%–90%, where the CO₂-capture rate is considered to be a constraint (*Case 1*). Each vertical dashed line indicates the start of a load change. Source: Paper IV.

Considering *Case 2*, Scheme C gives a lower specific heat requirement, and consequently, a higher power plant efficiency, at steady-state and for shorter settling times (*cf.* Figure 4.8 and Table 4.2). In Scheme D, a time delay of almost 50 minutes is observed in the response of the steam flow to the reboiler, regardless of whether ramping of the power plant load is up or down (see Figure 4.8b). This is due to the constant solvent flow rate throughout the operation and the significant time delay introduced by the system volume, before a change in the reboiler operating conditions, and consequently a change in the steam flow, is observed and the controller action is initiated.

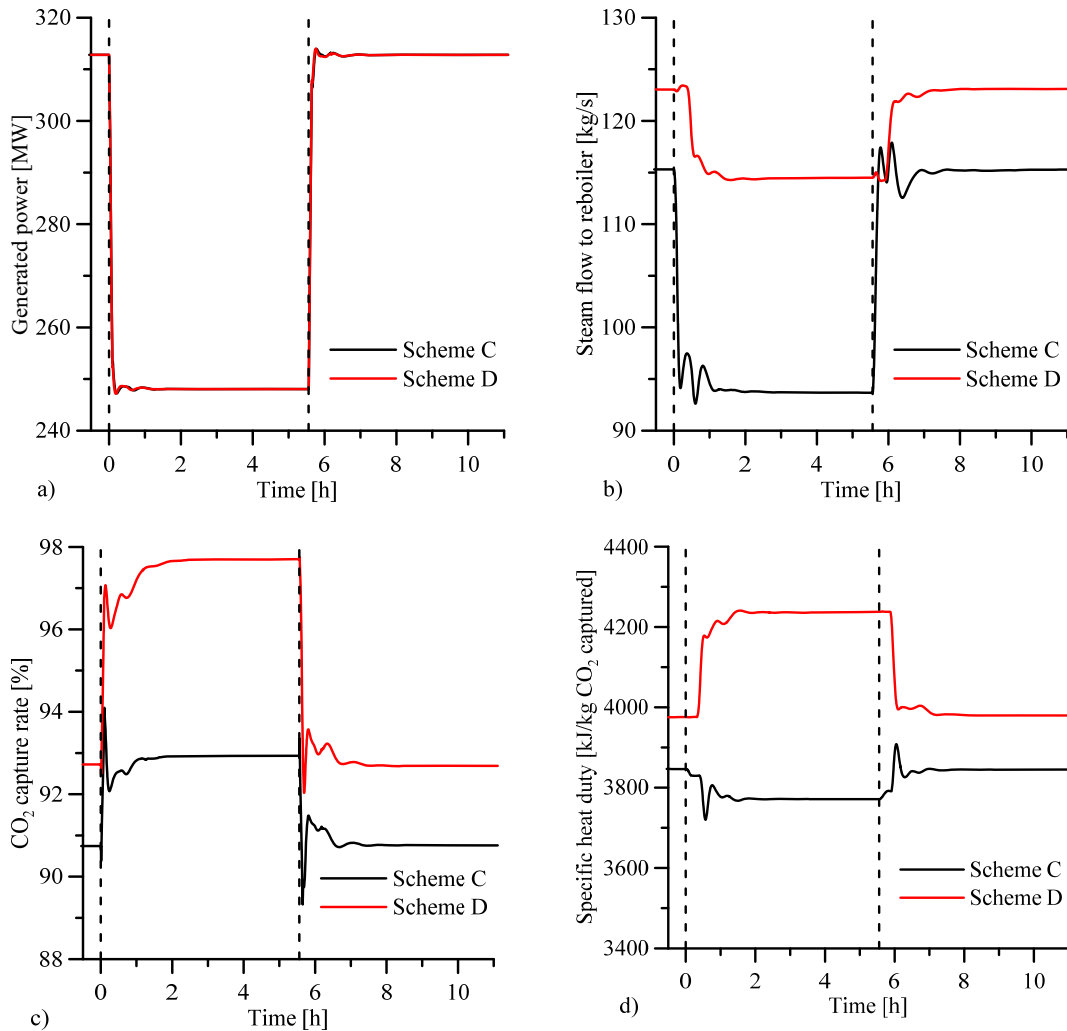

Figure 4.8: Responses in a power plant with CO₂ absorption for a load profile of 90%–70%–90% where the CO₂-capture rate is not considered a constraint (*Case 2*). Each vertical dashed line indicates the start of a load change. Source: Paper IV.

Dynamic behavior of CO₂ absorption integrated in coal-fired and natural gas combined-cycle plants

The interest in power plant transients with and without CO₂ capture not only relates to coal-based generation, but also to natural gas combined-cycle (NGCC) plants, especially considering the expansion of gas-based generation at the expense of coal in the last few years [4]. Therefore, it is also of interest to study and compare how the two technologies perform under load-varying conditions when operating with the same load ramps and control objectives with respect to the CO₂-capture plant. Recently, Montañés et al. [110] investigated the integration of CO₂ absorption with a state-of-the-art NGCC plant operated under dynamic conditions, applying a similar methodology as that described in **Paper IV**. The responses of the CO₂-absorption process, integrated with the coal-fired power plant investigated in this work and the NGCC plant presented by Montañés et al. [110], to the same load changes imposed in the two power plants are shown in Figure 4.9, in terms of the power plant load and the CO₂-capture rate. In the coal-based system, control Scheme A is applied, and a similar control

strategy is applied in the gas-based system, with the CO₂-capture rate as a higher-level control objective and the reboiler temperature being controlled by adjusting the steam flow to the reboiler. For the power plant mode of operation shown in Figure 4.9, the integrated systems exhibit similar responses in both the power plant and the CO₂ absorption process. This indicates that both power generation technologies can operate under varying load conditions without significant disruption of the power output by the CO₂ absorption process.

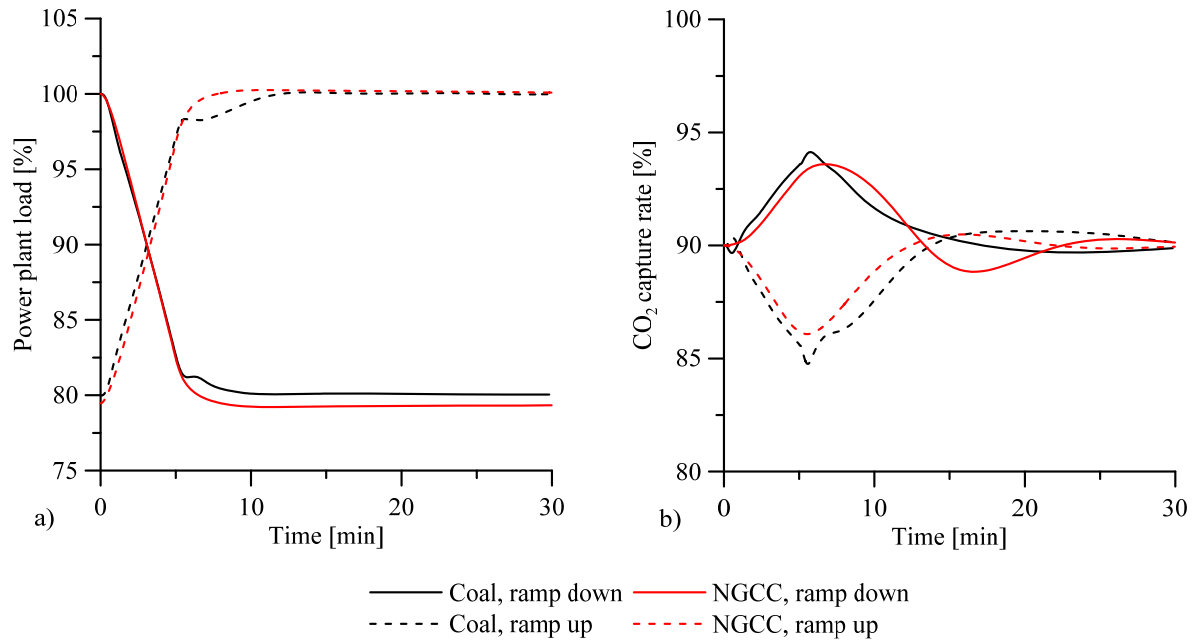

Figure 4.9: Responses in terms of: a) power plant load [%]; and b) CO₂-capture rate in the absorption unit [%] in PF and NGCC power plants with CO₂ absorption for a ramp down from 100% to 80% load and ramp up from 80% to 100% load. Adapted from [111] (Paper F).

4.2.2 Varying the steam availability

In this mode of operation, a fraction of the steam used for solvent regeneration is redirected to the steam cycle to increase power generation for a limited time. Here, the CO₂-absorption process is used to increase the maximum power output, acting as a provider of reserve capacity during periods of peak-load demand from the electricity system. The steam extraction valve between the power plant and the CO₂-absorption process is controlled to increase the electricity output of the power plant by 5% for 2 hours, before returning to normal operation. During this period, the steam flow to the reboiler is determined by the power plant, and only one DoF remains for the capture system, i.e., the solvent flow. Considered here are: one operational case in which control of the CO₂-capture rate is not possible and two control schemes are applied; one in which the reboiler temperature is a control variable; and one in which the L/G ratio is a control variable. The simulated responses of the generated power, the steam flow to the reboiler, the CO₂-capture rate, and the reboiler temperature in the integrated system during a period of reduced steam flow to the CO₂-absorption process are shown in Figure 4.10. For Schemes E and F, the system does not attain a steady state during the 2 hours of reduced steam availability, and the generated power fluctuates by ± 4 MW from the target value of 360 MW, although it approaches stable generation.

Operation with either of the proposed control schemes results in a rapid response in the power generation (cf. Figure 4.10, a and b). Scheme F also gives a rapid response in the CO₂-capture plant (cf. Figure 4.10c). Sharp overshoots in the generated power and the steam flow to reboiler are observed for Scheme E, and the CO₂-capture rate experiences a time delay of approximately 50 minutes before it responds to the reduced steam availability. This is explained by the constant L/G ratio (essentially constant solvent flow) in combination with the time delay introduced by the system volume, resulting in a delay in the increase in lean loading at the absorber inlet. The increase in lean loading results from insufficient solvent regeneration in the reboiler as the steam flow is reduced (cf. Figure 4.10d).

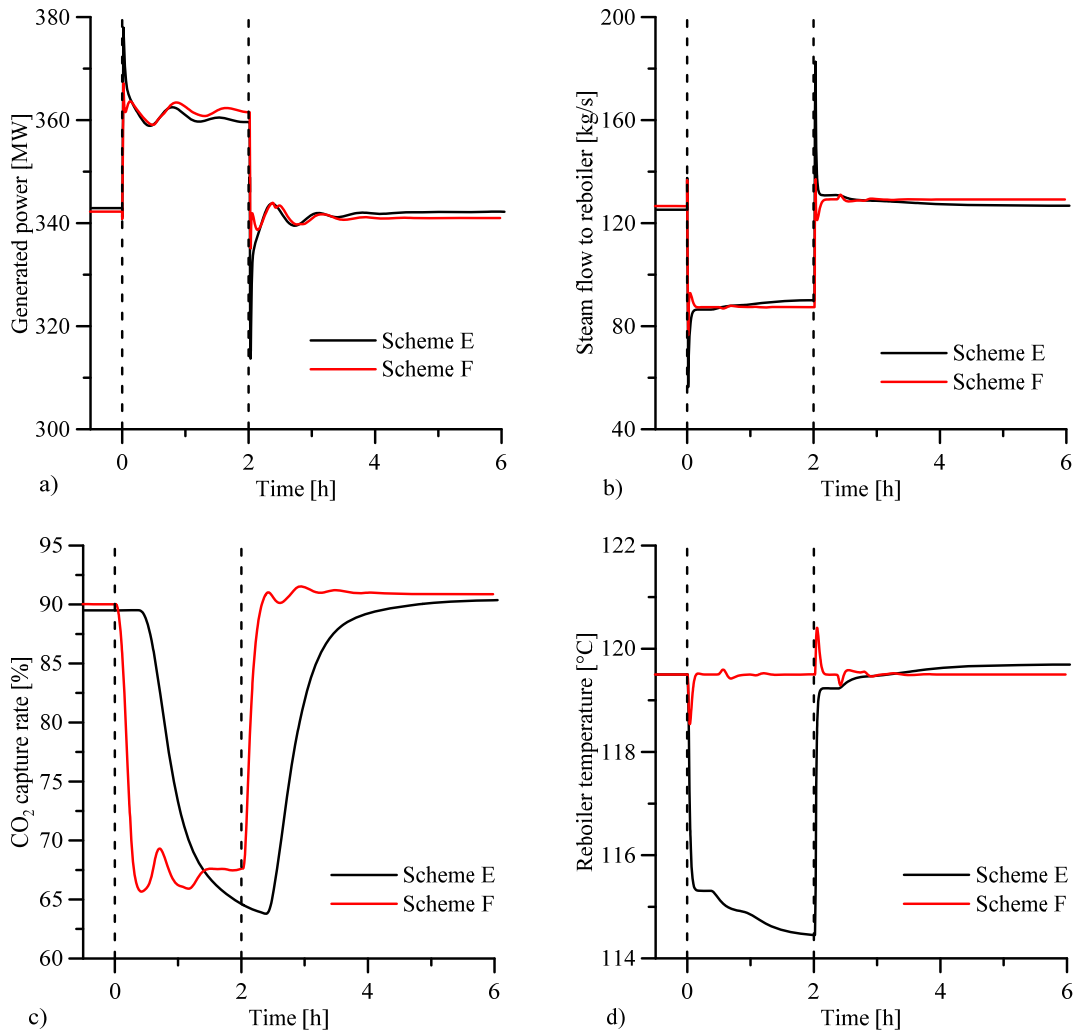

Figure 4.10: Effects on the generated power level (MW), steam flow to the reboiler (kg/s), CO₂-capture rate (%), and reboiler temperature of decreasing the amount of steam available for CO₂ capture. A ramp was applied (at t=0) for 1 minute to the valve position in the steam extraction line leading to the CO₂-absorption process. The new set-point was sustained for 2 hours before the operation was returned to full-load (100%), with no restrictions placed on steam availability. Each vertical dashed line indicates the start of a load change. Source: Paper IV.

In Scheme F, the rapid response observed in the integrated system is considerably smoother than that seen in Scheme E, in terms of both the overshoots of the steam flows and generated

power (*cf.* Figure 4.10, a and b). Furthermore, the system stabilizes more rapidly with Scheme F, as clearly seen in the CO₂-capture rate in Figure 4.10c. Considerable fluctuations are, however, observed in the CO₂-capture rate. This is explained by the solvent flow rate upstream of the absorber being regulated so as to maintain the liquid level in the absorber sump, with consequent impact on the CO₂-capture rate, while the solvent flow rate downstream of the absorber regulates the reboiler temperature. The reboiler temperature is itself relatively tightly controlled by the solvent circulation rate, and a deviation of only $\pm 1^{\circ}\text{C}$ from the temperature set-point is observed in Figure 4.10d, when the steam extraction valve position is changed.

4.3 Flexibility of coal power – effects on electricity system composition and costs

Increasing the competitiveness of coal-fired power plants in a future electricity system through improving plant flexibility and CO₂ emissions intensity was investigated in **Paper V** for two energy policy scenarios, as presented in Table 4.3. The two energy policy scenarios are applied to the three regional electricity generation systems listed in Table 3.2, and essentially address the two main challenges faced by thermal power generation: operation in load-following conditions with reduced capacity factors, i.e., increased cycling; and operation with near-zero emissions. Both scenarios include distinct cases in which investments in flexible coal-based technologies, i.e., with improved cycling properties, are blocked. In the *CO₂ emission cap* scenario, a case with improved fuel flexibility for co-firing technologies is also investigated. The improved fuel flexibility is represented by an increase (from 11% to 15%) in the share of biomass co-firing.

Table 4.3: Overview of the investigated energy policy scenarios and associated investment cases. Adapted from Table 2 in Paper V.

Energy policy scenario	Case ID	Flexible coal investments	Increased co-firing of biomass
Renewable energy policy – 65% of yearly generation from renewable energy sources	Baseline	No	No
	Flex	Yes	No
CO ₂ emission cap – 99.5% reduction in emissions relative to Year 1990	Baseline	No	No
	Flex	Yes	No
	Bio share	Yes (only with respect to increased co-firing)	Yes

The screening curves, which show the relationships between annual running costs and capacity factors for thermal power technologies present in the two investigated energy policy scenarios, are presented in Figure 4.11. The screening curves generally show how technologies that have relatively high investment costs but low running costs, primarily coal and nuclear, outperform (bio)gas-based technologies at high capacity factors, i.e., with a high number of full-load hours. Furthermore, the technologies that are viable in the *CO₂ emission cap* scenario entail significantly higher costs compared with the technologies included in the *Renewable energy policy* scenario. In this work, the costs of the flexible coal-based technologies are regarded as being equal to their respective less-flexible counterparts. For this reason, the screening curves for the flexible technologies are identical to the curves for the less-flexible counterparts, as shown in Figure 4.11.

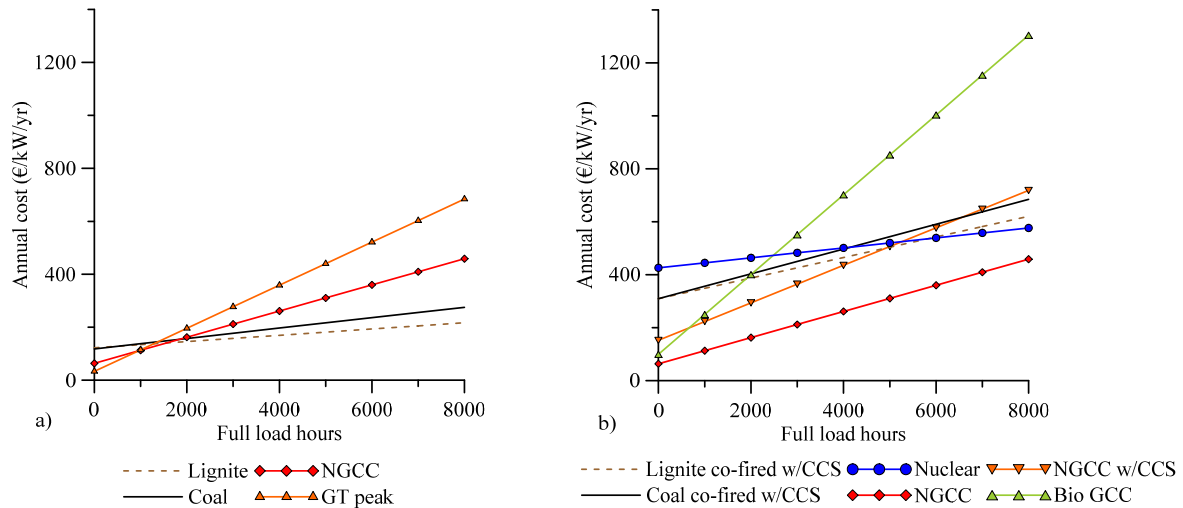

Figure 4.11: Screening curves for: a) the fossil-based thermal power technologies present in the *Renewable energy policy* scenario; and b) the co-firing coal-based, nuclear, NGCC with and without CCS, and Bio-GCC technologies present in the *CO₂ emission cap* scenario. Adapted from Figure 3 and Figure 7 in Paper V.

4.3.1 Renewable energy policy scenario

Figure 4.12 shows the cost-optimal system composition and the resulting electricity generation cost for the *Baseline* and *Flex* cases, in a system where there is a requirement for renewable energy sources (RES) to account for 65% of yearly generation. Favorable conditions for wind in Region 1 result in no other RES-based technologies being competitive in this region, while Regions 2 and 3 has a considerable solar-based capacity together with wind.

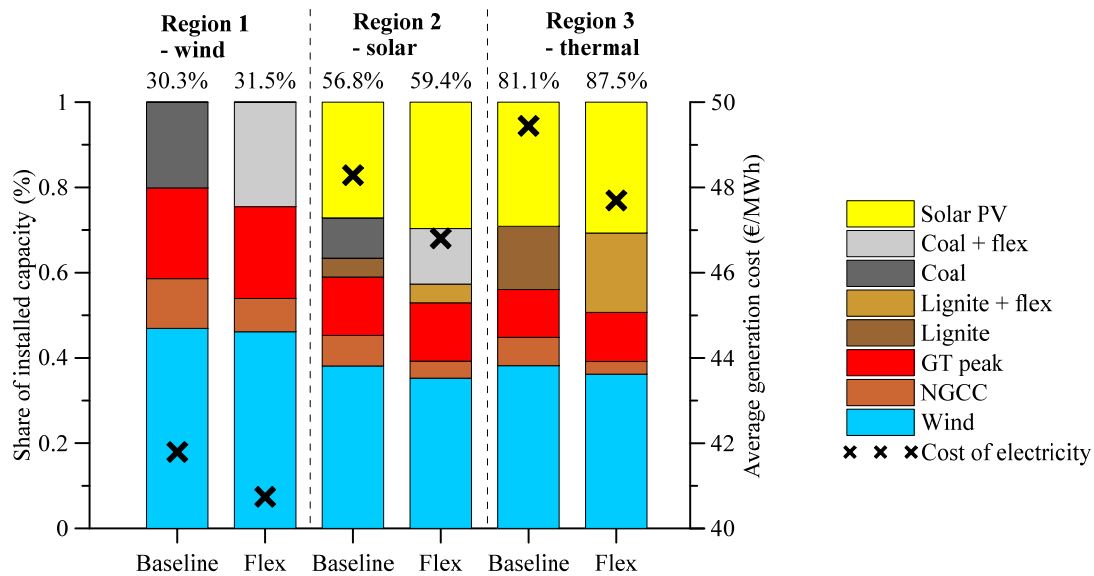

Figure 4.12: Modeled system composition in the *Renewable energy policy* scenario, with a requirement that 65% of the yearly demand be supplied by renewables, for the three regions investigated for the Baseline and Flex cases. Note that the second y-axis for average generation cost starts at 40 €/MWh. The resulting CO₂ emission levels relative to Year 1990 are presented in percentages above the bars. Adapted from Figure 2 and Table 5 in Paper V.

When there are no restrictions on CO₂ emissions, there is room for significant capacity of coal-based technologies operating with high full-load hours in all regions. At the same time, the combined penetration levels of RES-based technologies fulfill the requirement for a 65% share of the total generation. The screening curves for the thermal power technologies present in the scenario in Figure 4.11a show that coal-based technologies outperform gas-based technologies when there are more than 2,000 full-load hours. Furthermore, with the low cycling costs of coal-based technologies that have improved operating flexibility (not shown in Figure 4.11a), a significant investment in these technologies can be expected in the *Flex* case. With improved cycling properties, the flexible coal-based technologies can provide flexibility similar to that conferred by NGCC, albeit at a lower cost. Comparing the *Flex* case with the *Baseline* case, an increase in the capacity of coal-based generation is observed as the capacity of NGCC decreases. Improved coal-based flexibility results in reduced wind curtailment and slightly smaller investments are required to reach the 65% RES energy generation target as wind power capacity factors are increased (not shown in Figure 4.12).

The inclusion of flexible coal-based technologies results in reduced average electricity generation costs in all regions. This reduction is around 2%–4% compared with the *Baseline* case, with the greatest impact seen in Region 3, which has the poorest conditions for wind and solar power. In Regions 2 and 3, investments in solar power generation benefit from the improved coal-based flexibility, in terms of the share of installed capacity in the systems. However, the increased capacity and cycling of coal-based technologies and the reduced generation from NGCC in the *Flex* case result in increased CO₂ emission levels.

4.3.2 CO₂ emission cap scenario

The cost-optimal composition and the resulting electricity generation cost in the three investigated regions for the *Baseline*, *Flex* and *Bio share* cases in the *CO₂ emission cap* scenario are shown in Figure 4.13. The CO₂ emission cap indirectly forces investments in RES and nuclear power when available, and coal-based technologies are only viable when co-fired with biomass and operated with CCS owing to the stringent CO₂ cap (note that Region 1 has no local lignite reserves, so only hard coal is available).

Due to the stringent CO₂ emission cap, there is essentially no scope for the cycling of coal-based technologies, as their cycling, primarily during start-up operation, entails emissions (CCS is assumed to be non-operational during start-up). Variation management is mainly provided by Bio-GCC, which has zero-cycling emissions and a relatively low cost at low capacity factors, and to a small extent by NGCC (*cf.* Figure 4.11b). However, the results show that the possibility for coal-based technologies to operate at lower loads would make them more competitive with gas-based technologies. Comparing the *Flex* case with the *Baseline* case, a slight increase in the capacity of coal-based generation is observed, which results in a small reduction in expensive nuclear capacity and Bio-GCC, and thereby a small decrease in the electricity generation costs. Furthermore, the reduced operating loads for coal improve the market conditions for investments in wind (all regions) and solar (Regions 2 and 3) power.

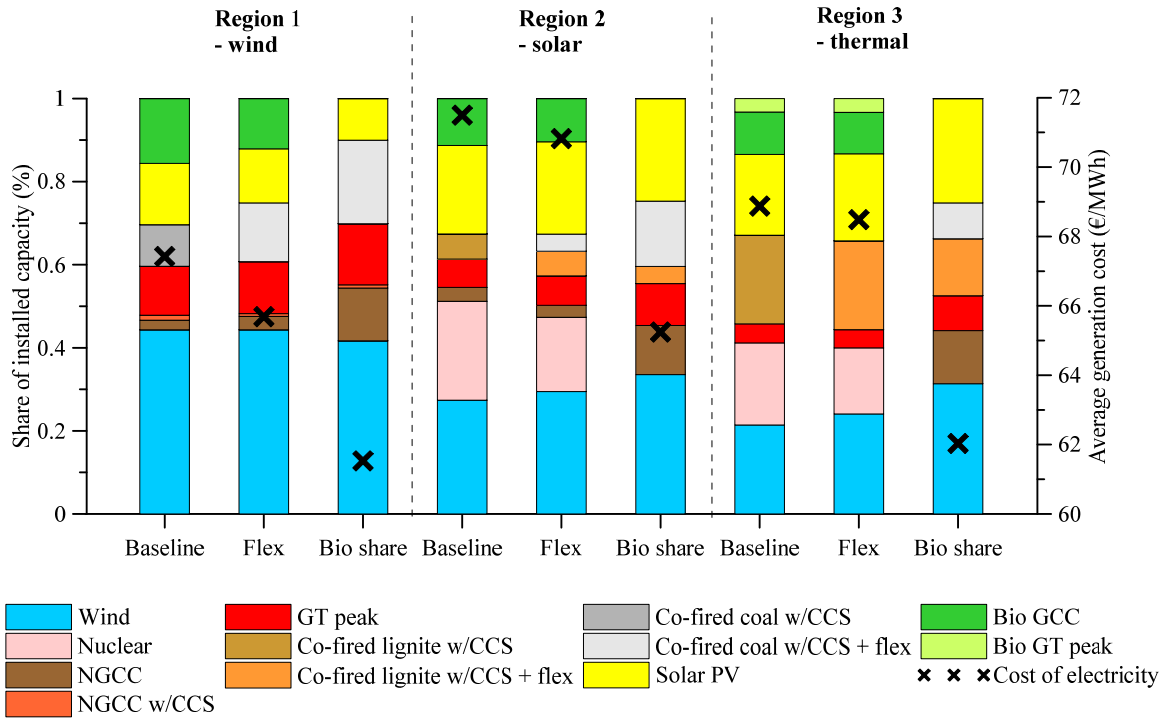

Figure 4.13: Modeled system composition and cost of electricity in the CO_2 emission cap scenario for the three regions investigated for the *Baseline*, *Flex* and *Bio share* cases. Adapted from Figure 6 in Paper V.

The increased co-firing capabilities seen in the *Bio share* case result in negative CO_2 emissions from these technologies. The results show that this holds more value for a system with a strict CO_2 emission cap than improved cycling properties (*cf.* Figure 4.13), as it allows for the provision of variation management by relatively inexpensive technologies with cycling emissions, i.e., NGCC without CCS (*cf.* Figure 4.11b). The more expensive Bio-GCC capacity, which provides variation management in the *Baseline* and *Flex* cases, is thus not required in the *Bio share* case. Although a smaller investment is made in lignite-based capacity in the *Bio share* case compared to the *Baseline* case, the capacity factor of lignite-based technologies is increased (not shown in Figure 4.13). A significant capacity of hard coal also enters the system in all regions, effectively eliminating nuclear capacity in Regions 2 and 3. The conditions for investments in wind and solar power are improved.

5 Discussion

The results presented in this thesis provide new insights into the requisite conditions for fossil-based industries and coal-based power generation to operate in future energy systems that have large shares of renewable energy, in that they are driven by strict constraints on CO₂ emissions. It is clear that the possibilities for drastic carbon reductions and the suitability of mitigation options vary considerably between industries. This stimulates an important discussion as to how the responsibility and cost of such measures should be distributed. Below is a discussion on five aspects of this topic based on the results and focus of this thesis:

- i) the influence of emission source on the cost of the CO₂-absorption process;
- ii) the cost of carbon capture in the process industry from the plant owner's perspective;
- iii) the cost of carbon capture in the process industry from the societal perspective;
- iv) the variable operation of coal power from the plant owner's perspective; and
- v) the variable operation of coal power from an energy system perspective.

Research on CO₂ absorption has traditionally focused on reducing the cost of the technology through the development of new materials and process designs, and this has resulted in CO₂ absorption becoming a commercially available technology [21]. Energy-related costs are the single largest cost factor and, thus, extensive research efforts are directed towards reducing the heat requirement of CO₂ absorption and achieving efficient utilization of low-cost heat. The results presented in this work show that a high content of CO₂ in flue gas streams is favorable for CO₂ absorption, as it reduces the heat requirement for solvent regeneration and, consequently, the energy-related costs. As an example, doubling the CO₂ content from 10 mol% to 20 mol% reduces the specific heat requirement by around 200 kJ/kgCO₂, or around 5%. However, the economy of scale is shown to have an even stronger effect on the specific costs (€/tCO₂). For example, capturing 800 kt/a of CO₂ rather than 400 kt/a from a source with 13 mol% CO₂ reduces the specific investment cost by around 23%. In this perspective, large industrial plants with relatively highly concentrated CO₂ streams, such as oil refineries and steel mills, are attractive candidates for CO₂ capture deployment, and they might also offer opportunities for waste heat utilization.

The perceived high upfront cost of CO₂ capture from the plant owner's perspective, and the lack of effective policy measures to stimulate investments in CO₂ capture are generally regarded as the main barriers for large-scale deployment of CO₂ capture (though other factors, such as CO₂ storage and public acceptance, also pose challenges). The costs reported in this thesis for investments in CO₂ capture from industrial sources on the facility level may be regarded as high. However, compared with recent investments made in industry, which have

resulted in CO₂ reductions (although these investments were not solely motivated by reducing CO₂ emissions but also other reasons, such as increased fuel flexibility), the scale of costs is similar. An example of this is the new LNG terminal at Preem's oil refinery in Lysekil in 2014, with a reported investment of about 85 M€ and enabled a reduction in CO₂ emissions of 130 kt/a [112]. This investment is comparable to the estimated investment for CO₂ absorption from the H₂ production unit at the same refinery (83 M€ for a reduction of 386 ktCO₂/a).

Long term European climate targets aim for a drastic reduction in emission from both power and industry sectors, most likely requiring significant deployment of CO₂ capture at some stage. Figure 5.1 gives an estimate of the cost of the required CCS capacity from the emission sources investigated in **Paper II**, when targeting net zero CO₂ emissions from the process industry by Year 2045, in line with the recent climate framework approved by the Swedish government [113]. The cost is given as marginal cost as well as an average, assuming a emission reduction corresponding to the current fossil fuel emissions of 17.2 Mt CO₂/a [105]. The marginal cost is the cost of the unit with the highest cost for CCS, i.e. CO₂ capture is applied to units starting with the one with lowest cost (*cf.* Figure 4.4a) and adding units in ascending cost-order until 17.2 Mt CO₂/a is captured. For comparison, the total CO₂ capture capacity from the fossil sources shown in Figure 4.4 and associated costs are also shown in Figure 5.1. The importance of large-scale BECCS from Swedish emission sources to achieve the national emission targets is clear as limited CO₂ reductions are achieved by only targeting large-scale fossil sources, which also results in higher average and marginal costs for CCS. When only targeting fossil sources, CCS from many smaller sources (not included in Figure 5.1), presumably at much higher costs than presented here, would be required to reach zero CO₂ emissions in the process industry. However, there are currently no incentives in place that stimulate reductions of biogenic CO₂ emissions.

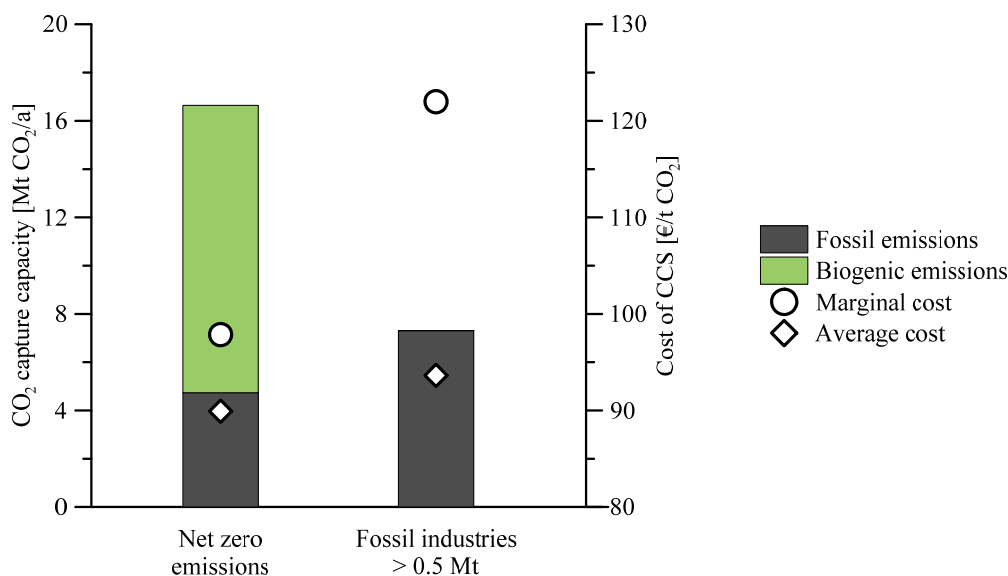

Figure 5.1: Marginal and average costs of CCS (in €₂₀₁₅/t CO₂ captured and stored) for the CO₂ capture capacity required to reach net-zero CO₂ emissions from the Swedish process industry (left bar) and the total CO₂ capture capacity from Swedish fossil-based process industries with emissions > 0.5 Mt CO₂/a (right bar). The cost of CCS for the required CO₂ capture capacity is estimated starting from the sources with the lowest specific CAPEX (cf. Figure 4.4a) and including sources with increasing mitigation cost until net zero emissions are achieved. The specific CO₂ capture cost is estimated using the economic assumptions presented in Table 3.1, while the specific cost for CO₂ transport and storage is based on estimates by Kjærstad et al. [102] and from the NORDICCS project [114]. Source: Paper II.

The expansion of the capacity of electricity generation from variable renewables, i.e., wind and solar, raises questions regarding the operation of the remaining thermal power generation units and the ways in which variations in electricity generation can be handled effectively. It is unclear if and when CCS will be implemented on a large-scale in the power sector, given the continued lack of political will to employ policies or develop market instruments that would facilitate the deployment of CO₂-capture technologies. However, should coal-fired power plants equipped with CO₂ absorption become a reality, the results presented in this work indicate that the CO₂-absorption process would not strongly influence the load-following capabilities of the plant (the power output is shown to stabilize in 6–9 minutes, whether equipped with CO₂ absorption or not). Even though fluctuations in process variables are observed during operation with varying steam availability for the CO₂-absorption process, the power plant owner could increase the maximum power output and still be able to participate in a day-ahead energy market, where electricity is sold by the hour. However, it is also shown in this work that if a strict CO₂ cap is imposed, frequent cycling of the power plant may not be possible due to the associated increase in emissions – and this is also likely to be true for operation with a reduced CO₂-capture rate to increase temporarily the power output.

As for the current situation in Europe, policy-wise, regional measures, such as green electricity certificates and feed-in tariffs, have strongly stimulated investments in variable renewables, resulting in increasingly variable operation of existing thermal power plants. As a result, providers of coal power technology are focusing on developing technologies that increase plant operating flexibility to improve competitiveness, especially with respect to gas-based technologies. This work shows that coal plants with improved cycling properties (and without

CO₂ capture) can supply low-cost flexibility, reduce system costs, reduce wind curtailment, and improve the conditions for solar power deployment, as exemplified for a system with 65% penetration of renewables. The improved cycling properties increase the competitiveness of coal-based technologies compared to NGCC plants, as they can provide similar flexibility at a lower cost. With more stringent requirements for generation from renewables, NGCC plants become increasingly more attractive than coal-based technologies, as utilization times decrease and low investment costs become more important than low running costs (*cf.* Figure 4.11a). If CO₂ emission constraints become stricter and coal plants are required to operate with CO₂ capture, the possibility for coal to contribute to variation management will be limited, due to the presence of cycling emissions. Instead, thermal flexibility will have to be provided by low-emission (bio)-gas technologies.

6 Conclusions

This thesis investigates the operation and design of fossil-based power generation and industrial processes in future energy systems that have strict constraints on CO₂ emissions, and consequently, exhibit large shares of renewable energy (**Paper V**). The focus is on the application of CO₂ absorption to thermal power generation (**Papers I, III, IV**) and the process industry (**Papers I and II**). The results obtained from the work show that:

With appropriate design of the capture process, the specific heat requirement for solvent regeneration is lower for flue gases that have a high content of CO₂. The flue gas CO₂ concentration may vary considerably (1–40 mol%) between industrial processes, translating to a difference in specific heat requirement of 1000 kJ/kgCO₂. For flue gas CO₂ concentrations >20 mol%, it is important to control the temperature of the absorber using intercooling, as it will reduce the specific heat requirement of the process by 100–300 kJ/kgCO₂. This is especially important for solvents that have high reactivity or high heat of reaction, and when the solvent concentration is high.

From the economic perspective, the treated volume of gases and the flue gas CO₂ concentration are important factors. For a given volume flow and constant capture rate, an increase in the CO₂ concentration increases the CO₂-capture cost in absolute terms (€) and decreases the capture cost in specific terms (€/tCO₂ captured). The economy of scale has a strong impact on the specific cost, and low specific investment costs for CO₂ absorption in the range of 10–20 €/tCO₂ are found for large point sources, such as steel mills, cement plants, and pulp mills. During ramp-up, the required investments in transport infrastructure are on the same scale as investments in CO₂-capture plants. This highlights the importance of effective policy instruments and some form of governmental support for securing the required investments in infrastructure, so as to enable the implementation of CCS chains.

Modeling an integrated power plant-CO₂ absorption system to account for potential interactions between these two processes instead of considering power plant transients as boundary conditions for the CO₂ absorption plant results in an order of magnitude increase in the stabilization time in the CO₂-absorption plant. This highlights the importance of accounting for the dynamic interactions between the CO₂-absorption plant and the power plant.

During load transitions in a power plant with CO₂ absorption, the power generation stabilizes much faster, generally in under 10 minutes, than the CO₂ absorption process, which typically requires more than an hour to reach steady-state operation. A similar stabilization time is observed in the generated power in a power plant without CO₂ absorption. Thus, the CO₂-

absorption process does not significantly affect the load-following capabilities of the power plant. However, the control scheme for the CO₂-absorption process is important, as pairing of the control variables in relatively slow control loops results in the power output stabilizing in up to 30 minutes. Controlling either the CO₂ capture rate or the L/G ratio with the solvent flow rate upstream of the absorber results in rapid stabilization of the power output.

Strict CO₂ targets on a system level create more-adverse conditions for investments in flexible coal-based generation than strict targets for the penetration of variable renewables. Improving the operational flexibility of coal-based generation with respect to shorter start-up times and lower minimum load levels benefits the electricity system through improved capacity factors for wind and solar power. A tight CO₂ cap (99.5% reduction relative to the Year 1990 emission levels, which makes CO₂ capture a prerequisite for continued use of coal-based technologies) will limit the possibility for coal to provide variation management, due to cycling emissions.

6.1 Considerations for future research

The work and results presented in this thesis cover the integration and operation of CO₂ absorption in combination with power generation and industrial processes. During the discussion of the results, new interesting questions and important issues have been identified:

- The effects of transients and varying load in various industrial emissions sources on CO₂ absorption are of interest. To date, this aspect has only been considered for power generation. Insights on the utilization and operation, both on shorter time-scales (as considered in **Papers III** and **IV**) and in a seasonal time perspective, are highly relevant to the cost of CCS. The latter time-scale is especially relevant to Swedish conditions, where many industrial facilities are providers of district heat, which is a seasonal product, which means that the amount and quality of excess heat for use in the absorption process might vary considerably over the year. This raises questions as to how efficient process design can take advantage of seasonal variations.
- The impact of increasing the maximum power output of a coal-fired plant that is integrated with CO₂ absorption to provide reserve capacity and other ancillary services in shorter time-scales to the power grid warrants further study. In this context, it would be of interest to investigate the potentials of both retrofitted and capture-ready power plants to provide the various ancillary services, given their different designs of the low-pressure steam turbine section.
- From the electricity system perspective, the potential of industrial facilities, with electricity generation as a by-product, to provide variation management is rarely discussed. Large-scale steel and pulp mills often operate with considerable excess power generation, raising important questions as to how these facilities could participate in balancing a local electricity system.

7 Bibliography

- [1] IEA. 2016. *CO₂ Emissions from Fuel Combustion - Highlights*. International Energy Agency. Paris, France
- [2] IEA. 2016. *Key world energy statistics*. International Energy Agency. Paris, France
- [3] UNFCCC. 2017. *The Paris Agreement*. United Nations Framework Convention on Climate Change.
- [4] IEA. 2016. *World Energy Outlook*. International Energy Agency. Paris, France
- [5] IEA. 2014. *Key World Energy Statistics*. International Energy Agency. Paris, France
- [6] Frondel, M., Ritter, N., Schmidt, C.M., and Vance, C., 2010. *Economic impacts from the promotion of renewable energy technologies: The German experience*. *Energy Policy*, **38**, pp. 4048-4056.
- [7] Bergeck, A. and Jacobsson, S., 2010. *Are tradable green certificates a cost-efficient policy driving technical change or a rent-generating machine? Lessons from Sweden 2003–2008*. *Energy Policy*, **38**, pp. 1255-1271.
- [8] Rootzén, J. and Johnsson, F., 2013. *Exploring the limits for CO₂ emission abatement in the EU power and industry sectors-Awaiting a breakthrough*. *Energy Policy*, **59**, pp. 443-458.
- [9] Rootzén, J., Kjärstad, J., and Johnsson, F., 2011. *Prospects for CO₂ capture in European industry*. *Management of Environmental Quality: An International Journal*, **22**, pp. 18-32.
- [10] IEA. 2013. *Technology Roadmap - Carbon capture and storage*. International Energy Agency. Paris, France
- [11] IPCC. 2005. *Special report on Carbon dioxide Capture and Storage*. Intergovernmental Panel on Climate Change C.U. Press. New York, Cambridge
- [12] Stéphenne, K. *Start-up of world's first commercial post-combustion coal fired ccs project: Contribution of shell cansolv to saskpower boundary dam iccs project*. in *Energy Procedia*. 2014.
- [13] Statoil. 2013. *Sleipner West*. Available at: <http://www.statoil.com/en/TechnologyInnovation/NewEnergy/Co2CaptureStorage/Pages/SleipnerVest.aspx>
- [14] Rootzén, J., 2015. *Pathways to deep decarbonisation of carbon-intensive industry in the European Union - Techno-economic assessments of key technologies and measures* (PhD. Thesis). Chalmers University of Technology,
- [15] Hammer, G., Lübcke, T., Kettner, R., Pillarella, M.R., Recknagel, H., Commichau, A., Neumann, H.-J., and Paczynska-Lahme, B., *Natural Gas*, in *Ullmann's Encyclopedia of Industrial Chemistry*. 2000, Wiley-VCH Verlag GmbH & Co. KGaA.
- [16] Jilvero, H., Normann, F., Andersson, K., and Johnsson, F., 2012. *Heat requirement for regeneration of aqueous ammonia in post-combustion carbon dioxide capture*. *International Journal of Greenhouse Gas Control*, **11**, pp. 181-187.
- [17] Wang, M., Lawal, A., Stephenson, P., Sidders, J., and Ramshaw, C., 2011. *Post-combustion CO₂ capture with chemical absorption: A state-of-the-art review*. *Chemical Engineering Research and Design*, **89**, pp. 1609-1624.

- [18] Rochelle, G., Chen, E., Freeman, S., Van Wagener, D., Xu, Q., and Voice, A., 2011. *Aqueous piperazine as the new standard for CO₂ capture technology*. Chemical Engineering Journal, **171**, pp. 725-733.
- [19] Kamijo, T., Sorimachi, Y., Shimada, D., Miyamoto, O., Endo, T., Nagayasu, H., and Mangiaracina, A., 2013. *Result of the 60 tpd CO₂ capture pilot plant in European coal power plant with KS-ITM solvent*. Energy Procedia, **37**, pp. 813-816.
- [20] Liang, Z., Rongwong, W., Liu, H., Fu, K., Gao, H., Cao, F., Zhang, R., Sema, T., Henni, A., Sumon, K., Nath, D., Gelowitz, D., Srisang, W., Saiwan, C., Benamor, A., Al-Marri, M., Shi, H., Supap, T., Chan, C., Zhou, Q., Abu-Zahra, M., Wilson, M., Olson, W., Idem, R., and Tontiwachwuthikul, P., 2015. *Recent progress and new developments in post-combustion carbon-capture technology with amine based solvents*. International Journal of Greenhouse Gas Control, **40**, pp. 26-54.
- [21] Rochelle, G.T., *Conventional amine scrubbing for CO₂ capture*, in *Absorption-Based Post-Combustion Capture of Carbon Dioxide*, P.H.M. Feron, Editor. 2016. p. 35-67.
- [22] Campbell, M., 2014. *Technology Innovation & Advancements for Shell Cansolv CO₂ capture solvents*. Energy Procedia, **63**, pp. 801-807.
- [23] Reddy, S., Johnson, D., and Gilmartin, J. *Fluor's econamine FG plusSM technology for CO₂ capture at coal-fired power plants*. in *Air and Waste Management Association - 7th Power Plant Air Pollutant Control 'Mega' Symposium 2008*. 2008.
- [24] Knudsen, J.N., Bade, O.M., Askestad, I., Gorset, O., and Mejdell, T., 2014. *Pilot Plant Demonstration of CO₂ Capture from Cement Plant with Advanced Amine Technology*. Energy Procedia, **63**, pp. 6464-6475.
- [25] Darde, V., Thomsen, K., van Well, W.J.M., and Stenby, E.H., 2010. *Chilled Ammonia Process for CO₂ Capture*. International Journal of Greenhouse Gas Control, **4**, pp. 131-136.
- [26] Jilvero, H., 2014. *Ammonia as an Absorbent of Carbon Dioxide in Post-combustion Capture - an Experimental, Technical and Economic Process Evaluation* (Ph.D. Thesis). Chalmers University of Technology, Gothenburg, Sweden.
- [27] Wang, S. and Xu, Z., *Dual-liquid phase systems*, in *Absorption-Based Post-Combustion Capture of Carbon Dioxide*, P.H.M. Feron, Editor. 2016. p. 201-223.
- [28] Bara, J.E., *Ionic liquids for post-combustion CO₂ capture*, in *Absorption-Based Post-Combustion Capture of Carbon Dioxide*, P.H.M. Feron, Editor. 2016. p. 259-282.
- [29] Kuramochi, T., Ramirez, A., Turkenburg, W., and Faaij, A., 2012. *Comparative assessment of CO₂ capture technologies for carbon-intensive industrial processes*. Progress in Energy and Combustion Science, **38**, pp. 87-112.
- [30] Arasto, A., Tsupari, E., Kärki, J., Pisilä, E., and Sorsamäki, L., 2013. *Post-combustion capture of CO₂ at an integrated steel mill - Part I: Technical concept analysis*. International Journal of Greenhouse Gas Control, **16**, pp. 271-277.
- [31] Tsupari, E., Kärki, J., Arasto, A., and Pisilä, E., 2013. *Post-combustion capture of CO₂ at an integrated steel mill – Part II: Economic feasibility*. International Journal of Greenhouse Gas Control, **16**, pp. 278-286.
- [32] Hooey, L., Bodén, A., Larsson, M., Knights, M., Johns, J., Abraham, V., Tobiesen, A., Hoff, K.A., Haugen, G., and Goldthorpe, S. 2013. *Iron and Steel CCS study (Techno-Economics Integrated Steel Mill)*. IEAGHG.
- [33] ULCOS. 2017. *The Ultra-Low CO₂ Steelmaking (ULCOS) program*. Available at: <http://www.ulcos.org/en/>
- [34] Global CCS Institute (GCCSI). 2017. *Abu Dhabi CCS (Phase 1 being Emirates Steel Industries)*. Available at: <https://www.globalccsinstitute.com/projects/abu-dhabi-ccs-project-phase-1-being-emirates-steel-industries-esi-ccs-project>
- [35] IEAGHG. 2013. *Deployment of CCS in the Cement Industry*. 2013/19.
- [36] Mathisen, A., Skinnemoen, M.M., and Nord, L.O., 2014. *Evaluating CO₂ capture technologies for retrofit in cement plant*. Energy Procedia, **63**, pp. 6484-6491.
- [37] Bjerger, L.-M. and Brevik, P., 2014. *CO₂ Capture in the Cement Industry, Norcem CO₂ Capture Project (Norway)*. Energy Procedia, **63**, pp. 6455-6463.

- [38] Jakobsen, J., Roussanaly, S., and Anantharaman, R., 2017. *A techno-economic case study of CO₂ capture, transport and storage chain from a cement plant in Norway*. Journal of Cleaner Production, **144**, pp. 523-539.
- [39] van Straelen, J., Geuzebroek, F., Goodchild, N., Protopapas, G., and Mahony, L., 2010. *CO₂ capture for refineries, a practical approach*. International Journal of Greenhouse Gas Control, **4**, pp. 316-320.
- [40] Meerman, J.C., Hamborg, E.S., van Keulen, T., Ramírez, A., Turkenburg, W., and Faaij, A., 2012. *Techno-economic assessment of CO₂ capture at steam methane reforming facilities using commercially available technology*. International Journal of Greenhouse Gas Control, **9**, pp. 160-171.
- [41] Johansson, D., Franck, P.-Å., and Berntsson, T., 2013. *CO₂ capture in oil refineries: Assessment of the capture avoidance costs associated with different heat supply options in a future energy market*. Energy Conversion and Management, **66**, pp. 127-142.
- [42] Berghout, N., van den Broek, M., and Faaij, A., 2013. *Techno-economic performance and challenges of applying CO₂ capture in the industry: A case study of five industrial plants*. International Journal of Greenhouse Gas Control, **17**, pp. 259-279.
- [43] Andersson, V., Franck, P.-Å., and Berntsson, T., 2016. *Techno-economic analysis of excess heat driven post-combustion CCS at an oil refinery*. International Journal of Greenhouse Gas Control, **45**, pp. 130-138.
- [44] Global CCS Institute (GCCSI). 2016. *Quest*. Available at: <https://www.globalccsinstitute.com/projects/quest>
- [45] Zhang, T., Lin, Q., Xue, Z., Munson, R., and Magneschi, G., 2017. *Sinopec Zhongyuan Oil Field Company Refinery CCS-EOR Project*. Energy Procedia, **114**, pp. 5869-5873.
- [46] Lombardo, G., Agarwal, R., and Askander, J., 2014. *Chilled Ammonia Process at Technology Center Mongstad – First Results*. Energy Procedia, **51**, pp. 31-39.
- [47] Gorset, O., Knudsen, J.N., Bade, O.M., and Askestad, I., 2014. *Results from testing of Aker Solutions advanced amine solvents at CO₂ Technology Centre Mongstad*. Energy Procedia, **63**, pp. 6267-6280.
- [48] Lassagne, O., Gosselin, L., Désilets, M., and Iliuta, M.C., 2013. *Techno-economic study of CO₂ capture for aluminum primary production for different electrolytic cell ventilation rates*. Chemical Engineering Journal, **230**, pp. 338-350.
- [49] Jilvero, H., Mathisen, A., Eldrup, N.-H., Normann, F., Johnsson, F., Müller, G.I., and Melaen, M.C., 2014. *Techno-economic Analysis of Carbon Capture at an Aluminum Production Plant – Comparison of Post-combustion Capture Using MEA and Ammonia*. Energy Procedia, **63**, pp. 6590-6601.
- [50] Möllersten, K., Gao, L., Yan, J., and Obersteiner, M., 2004. *Efficient energy systems with CO₂ capture and storage from renewable biomass in pulp and paper mills*. Renewable Energy, **29**, pp. 1583-1598.
- [51] Hektor, E., 2008. *Post-Combustion CO₂ Capture in Kraft Pulp and Paper Mills. Technologic Economic and System Aspects* (Ph.D. Thesis). Chalmers University of Technology,
- [52] Onarheim, K., Santos, S., Kangas, P., and Hankalin, V., 2017. *Performance and costs of CCS in the pulp and paper industry part 1: Performance of amine-based post-combustion CO₂ capture*. International Journal of Greenhouse Gas Control, **59**, pp. 58-73.
- [53] Onarheim, K., Kangas, P., Kaijaluoto, S., Hankalin, V., and Santos, S. 2016. *Techno-Economic Evaluation of Retrofitting CCS in a Market Pulp Mill and an Integrated Pulp and Board Mill*. IEAGHG.
- [54] Pettersson, K. and Harvey, S., 2012. *Comparison of black liquor gasification with other pulping biorefinery concepts – Systems analysis of economic performance and CO₂ emissions*. Energy, **37**, pp. 136-153.
- [55] Bertsch, J., Growitsch, C., Lorenczik, S., and Nagl, S. 2012. *Flexibility Options in European Electricity Markets in High RES-E Scenarios - Study on Behalf of the International Energy Agency*. Energiewirtschaftliches Institut an Der Universität Zu Köln.
- [56] Brouwer, A.S., van den Broek, M., Zappa, W., Turkenburg, W.C., and Faaij, A., 2016. *Least-cost options for integrating intermittent renewables in low-carbon power systems*. Applied Energy, **161**, pp. 48-74.

- [57] Eser, P., Singh, A., Chokani, N., and Abhari, R.S., 2016. *Effect of increased renewables generation on operation of thermal power plants*. Applied Energy, **164**, pp. 723-732.
- [58] Kubik, M.L., Coker, P.J., and Barlow, J.F., 2015. *Increasing thermal plant flexibility in a high renewables power system*. Applied Energy, **154**, pp. 102-111.
- [59] Göransson, L., Goop, J., Odenberger, M., and Johnsson, F., 2017. *Impact of thermal plant cycling on the cost-optimal composition of a regional electricity generation system*. Applied Energy, **197**, pp. 230-240.
- [60] Henderson, C. 2014. *Increasing the flexibility of coal-fired power plants*. IEA Clean Coal Centre.
- [61] Moenkert, P., Kluger, F., Brüggemann, H., and Schmidt, G., 2014. *Utilisation of biomass in power plants designed for coal combustion - Challenges, experience and technical solutions*. VGB PowerTech, **9**, pp.
- [62] Brüggemann, H., Gollnick, R., Ebert, K., and Kübel, M. *Design concept and operation experience of recent hard coal fired power plants*. in *The 7th International Conference on Clean Coal Technologies*. 2015. Kraków, Poland.
- [63] Brüggemann, H. *Conventional Firing Systems for Future Power Plants*. in *International Conference Power Plants*. 2012. Zlatibor, Serbia.
- [64] Kluger, F., Chen, Q., Weissinger, G., and Brüggemann, H. *Future High Efficient Lignite Power Stations - Dry Lignite Fired Boiler*. in *IEA CCC Workshop on upgrading and efficiency improvements in coal-fired plants*. 2012. Victoria, Australia.
- [65] Runvik, H., 2014. *Modelling and start-up optimization of a coal-fired power plant* (M.Sc. Thesis). Lund University,
- [66] Wu, X., Shen, J., Li, Y., and Lee, K.Y., 2014. *Fuzzy modeling and stable model predictive tracking control of large-scale power plants*. Journal of Process Control, **24**, pp. 1609-1626.
- [67] Heimann, G., 2015. *Increasing flexibility of lignite-fired power plants*. VGB PowerTech, **4**, pp. 47-51.
- [68] MHPS. 2014. *Modernisation of combustion system*. Mitsubishi Hitachi Power Systems Europe GmbH. Duisburg, Germany
- [69] Messerle, V.E., Ustimenko, A.B., Karpenko, Y.E., Chernetskiy, M.Y., Dekterev, A.A., and Filimonov, S.A., 2015. *Modeling and Full-Scale Tests of Vortex Plasma - Fuel Systems for Igniting High-Ash Power Plant Coal*. Thermal Engineering, **62**, pp. 442-451.
- [70] Domenichini, R., Mancuso, L., Ferrari, N., and Davison, J., 2013. *Operating Flexibility of Power Plants with Carbon Capture and Storage (CCS)*. Energy Procedia, **37**, pp. 2727-2737.
- [71] Goto, K., Yogo, K., and Higashii, T., 2013. *A review of efficiency penalty in a coal-fired power plant with post-combustion CO₂ capture*. Applied Energy, **111**, pp. 710-720.
- [72] Montañés, R.M., Dutta, R., Nord, L.O., Bolland, O., and Enaasen Flø, N., 2016. *Dynamic process model development, parameter estimation and validation with transient plant data collected from a MEA test campaign at the CO₂ Technology Transfer Center Mongstad*. Energy Procedia, **114**, pp. 1538-1550.
- [73] Bui, M., Gunawan, I., Verheyen, V., Feron, P., and Meuleman, E., 2016. *Flexible operation of CSIRO's post-combustion CO₂ capture pilot plant at the AGL Loy Yang power station*. International Journal of Greenhouse Gas Control, **48**, pp. 188-203.
- [74] Flø, N.E., Knuutila, H., Kvamsdal, H.M., and Hillestad, M., 2015. *Dynamic model validation of the post-combustion CO₂ absorption process*. International Journal of Greenhouse Gas Control, **41**, pp. 127-141.
- [75] Bui, M., Gunawan, I., Verheyen, V., Feron, P., Meuleman, E., and Adeloju, S., 2014. *Dynamic modelling and optimisation of flexible operation in post-combustion CO₂ capture plants—A review*. Computers & Chemical Engineering, **61**, pp. 245-265.
- [76] Lin, Y.J., Wong, D.S.H., Jang, S.S., and Ou, J.J., 2012. *Control strategies for flexible operation of power plant with CO₂ capture plant*. AIChE Journal, **58**, pp. 2697-2704.
- [77] Panahi, M. and Skogestad, S., 2011. *Economically efficient operation of CO₂ capturing process part I: Self-optimizing procedure for selecting the best controlled variables*. Chemical Engineering and Processing: Process Intensification, **50**, pp. 247-253.

- [78] Panahi, M. and Skogestad, S., 2012. *Economically efficient operation of CO₂ capturing process. Part II. Design of control layer*. Chemical Engineering and Processing: Process Intensification, **52**, pp. 112-124.
- [79] Léonard, G., Mogador, B.C., Belletante, S., and Heyen, G., 2013. *Dynamic modelling and control of a pilot plant for post-combustion CO₂ capture*. Computer Aided Chemical Engineering, **32**, pp. 451-456.
- [80] Nittaya, T., Douglas, P.L., Croiset, E., and Ricardez-Sandoval, L.A., 2014. *Dynamic modelling and control of MEA absorption processes for CO₂ capture from power plants*. Fuel, **116**, pp. 672-691.
- [81] Cormos, A.-M., Vasile, M., and Cristea, M.-V., 2015. *Flexible operation of CO₂ capture processes integrated with power plant using advanced control techniques*. Computer Aided Chemical Engineering, **37**, pp. 1547-1552.
- [82] Gaspar, J., Ricardez-Sandoval, L., Jørgensen, J.B., and Fosbøl, P.L., 2016. *Controllability and flexibility analysis of CO₂ post-combustion capture using piperazine and MEA*. International Journal of Greenhouse Gas Control, **51**, pp. 276-289.
- [83] Walters, M.S., Edgar, T.F., and Rochelle, G.T., 2016. *Regulatory Control of Amine Scrubbing for CO₂ Capture from Power Plants*. Industrial & Engineering Chemistry Research, **55**, pp. 4646-4657.
- [84] Mac Dowell, N. and Shah, N., 2014. *Dynamic modelling and analysis of a coal-fired power plant integrated with a novel split-flow configuration post-combustion CO₂ capture process*. International Journal of Greenhouse Gas Control, **27**, pp. 103-119.
- [85] Mac Dowell, N. and Shah, N., 2015. *The multi-period optimisation of an amine-based CO₂ capture process integrated with a super-critical coal-fired power station for flexible operation*. Computers & Chemical Engineering, **74**, pp. 169-183.
- [86] Lawal, A., Wang, M., Stephenson, P., and Obi, O., 2012. *Demonstrating full-scale post-combustion CO₂ capture for coal-fired power plants through dynamic modelling and simulation*. Fuel, **101**, pp. 115-128.
- [87] Wellner, K., Marx-Schubach, T., and Schmitz, G., 2016. *Dynamic Behavior of Coal-Fired Power Plants with Postcombustion CO₂ Capture*. Industrial & Engineering Chemistry Research, **55**, pp. 12038-12045.
- [88] IEAGHG. 2016. *Evaluation of process control strategies for normal, flexible and upset operation conditions of CO₂ post combustion capture processes*. 2016/07.
- [89] Zhang, Y., Chen, H., Chen, C.-C., Plaza, J.M., Dugas, R., and Rochelle, G.T., 2009. *Rate-Based Process Modeling Study of CO₂ Capture with Aqueous Monoethanolamine Solution*. Industrial & Engineering Chemistry Research, **48**, pp. 9233-9246.
- [90] Que, H. and Chen, C.-C., 2011. *Thermodynamic Modeling of the NH₃-CO₂-H₂O System with Electrolyte NRTL Model*. Industrial & Engineering Chemistry Research, **50**, pp. 11406-11421.
- [91] Åkesson, J., Laird, C.D., Lavedan, G., Pröllß, K., Tummescheit, H., Velut, S., and Zhu, Y., 2012. *Nonlinear Model Predictive Control of a CO₂ Post-Combustion Absorption Unit*. Chemical Engineering & Technology, **35**, pp. 445-454.
- [92] Modelon AB. 2015. *Post-Combustion Capture with Amine Solutions*. Available at: http://www.modelon.com/fileadmin/user_upload/Industries/Energy_Process/CCS/PostCombustionCapture_flyer.pdf
- [93] Hardarson, B. and Storm, J., 2008. *Heat Integration of Chilled Ammonia Process in a Pulverized Coal Power Plant* (M.Sc. Thesis). Chalmers University of Technology, Gothenburg, Sweden.
- [94] Modelon AB. 2015. *Thermal Power Library*. Available at: <http://www.modelon.com/products/modelica-libraries/thermal-power-library/>
- [95] Sanchez Fernandez, E., Sanchez del Rio, M., Chalmers, H., Khakharia, P., Goetheer, E.L.V., Gibbins, J., and Lucquiaud, M., 2016. *Operational flexibility options in power plants with integrated post-combustion capture*. International Journal of Greenhouse Gas Control, **48, Part 2**, pp. 275-289.
- [96] Liebenthal, U., Pinto, D.D.D., Monteiro, J.G.M.S., Svendsen, H.F., and Kather, A., 2013. *Overall Process Analysis and Optimisation for CO₂ Capture from Coal Fired Power Plants*

- based on Phase Change Solvents Forming Two Liquid Phases. *Energy Procedia*, **37**, pp. 1844-1854.
- [97] Lucquiaud, M. and Gibbins, J., 2009. *Retrofitting CO₂ capture ready fossil fuel plants with post-combustion capture. Part 1: requirements for supercritical pulverized coal plants using solvent-based flue gas scrubbing*. Proceedings of the Institution of Mechanical Engineers, Part A: Journal of Power and Energy, **223**, pp. 213-226.
- [98] Aske, E.M.B. and Skogestad, S., 2009. *Consistent Inventory Control*. *Industrial & Engineering Chemistry Research*, **48**, pp. 10892-10902.
- [99] Flø, N.E., Kvamsdal, H.M., Hillestad, M., and Mejdell, T., 2016. *Dominating dynamics of the post-combustion CO₂ absorption process*. *Computers & Chemical Engineering*, **86**, pp. 171-183.
- [100] van der Spek, M., Sanchez Fernandez, E., Eldrup, N.H., Skagestad, R., Ramirez, A., and Faaij, A., 2017. *Unravelling uncertainty and variability in early stage techno-economic assessments of carbon capture technologies*. *International Journal of Greenhouse Gas Control*, **56**, pp. 221-236.
- [101] European Commission. 2016. *Quarterly Report on European Electricity Markets, Volume 9, Issue 1; fourth quarter of 2015 and first quarter of 2016*.
- [102] Kjärstad, J., Skagestad, R., Eldrup, N.-H., and Johnsson, F., 2016. *Ship transport - A low cost and low risk CO₂ transport option in the Nordic countries*. *International Journal of Greenhouse Gas Control*, **54**, pp. 168-184.
- [103] Anthonsen, K.L., Aagaard, P., Bergmo, P.E.S., Gislason, S., Lothe, A.E., Mortensen, G.M., and Snæbjörnsdóttir, S.Ó., 2014. *Characterisation and selection of the most prospective CO₂ storage sites in the Nordic region*. *Energy Procedia*, **63**, pp. 4884-4896.
- [104] Gassco and Gassnova. 2015. *Mulighetsstudier av fullskala CO₂-håndtering i Norge*. Olje- og energidepartementet, Norge.
- [105] Naturvårdsverket. 2017. *Snabbstatistik, nationella utsläpp av växthusgaser år 2016*. Available at: <http://www.naturvardsverket.se/Sa-mar-miljon/Klimat-och-luft/Klimat/Tre-satt-att-berakna-klimatpaverkande-utslapp/Snabbstatistik-nationella-utslapp-av-vaxthusgaser-ar-2016/>
- [106] Jordal, K., Ystad, P.A.M., Anantharaman, R., Chikukwa, A., and Bolland, O., 2012. *Design-point and part-load considerations for natural gas combined cycle plants with post combustion capture*. *International Journal of Greenhouse Gas Control*, **11**, pp. 271-282.
- [107] Hanak, D.P., Biliyok, C., and Manovic, V., 2015. *Evaluation and modeling of part-load performance of coal-fired power plant with postcombustion CO₂ capture*. *Energy and Fuels*, **29**, pp. 3833-3844.
- [108] Gardarsdóttir, S.Ó., Normann, F., Andersson, K., Prölb, K., Emilsdóttir, S., and Johnsson, F., 2015. *Post-combustion CO₂ capture applied to a state-of-the-art coal-fired power plant - The influence of dynamic process conditions*. *International Journal of Greenhouse Gas Control*, **33**, pp. 51-62.
- [109] Ziaii, S., Rochelle, G.T., and Edgar, T.F., 2009. *Dynamic Modeling to Minimize Energy Use for CO₂ Capture in Power Plants by Aqueous Monoethanolamine*. *Industrial & Engineering Chemistry Research*, **48**, pp. 6105-6111.
- [110] Montañés, R.M., Gardarsdóttir, S.Ó., Normann, F., Johnsson, F., and Nord, L.O., 2017. *Demonstrating load-change transient performance of a commercial scale natural gas combined cycle power plant with post combustion CO₂ capture*. *International Journal of Greenhouse Gas Control*, **63**, pp. 158-174.
- [111] Montañés, R.M., Gardarsdóttir, S.O., Normann, F., Johnsson, F., and Nord, L.O. *Power plant dynamics with post-combustion CO₂ capture - A comparison between a supercritical coal fired and a natural gas combined cycle power plant*. in *The 9th Trondheim CCS conference*. 2017.
- [112] 2014. *Ny LNG-terminal hos Preemraff minskar koldioxidutsläppen med 130 000 ton/år*. Available at: <http://www.mynewsdesk.com/se/preem/pressreleases/ny-lng-terminal-hos-preemraff-minskar-koldioxidutslappen-med-130-000-ton-aar-1069773>
- [113] Miljömålsberedningen. 2016. *En klimat- och luftvårdsstrategi för Sverige*. Statens Offentliga Utredningar. Stockholm

- [114] Skagestad, R., Haugen, H.A., and Mathisen, A. 2015. *CCS case synthesis - Final Report*. NORDICCS - Nordic CCS Competence Centre. Technical Report D3.14.1501/D14

