

Discrete Dynamical Systems

Oded Galor
Brown University

April 1, 2005

Abstract

This manuscript analyzes the fundamental factors that govern the qualitative behavior of discrete dynamical systems. It introduces methods of analysis for stability analysis of discrete dynamical systems. The analysis focuses initially on the derivation of basic propositions about the factors that determine the local and global stability of discrete dynamical systems in the elementary context of a one dimensional, first-order, autonomous, systems. These propositions are subsequently generalized to account for stability analysis in a multi-dimensional, higher-order, non-autonomous, nonlinear, dynamical systems.

Keywords: Discrete Dynamical Systems, Difference Equations, Global Stability, Local Stability, Non-Linear Dynamics, Stable Manifolds.

JEL Classification Numbers: C62, O40

Table of Content

0. **Introduction**

1. **One-Dimensional, Autonomous, First-Order Systems**

1.1. **Linear Systems**

1.1.1. The Solution

1.1.2. Existence of Stationary Equilibria

1.1.3. Uniqueness of Stationary Equilibrium

1.1.4. Stability of Stationary Equilibria

1.2. **Nonlinear Systems**

1.2.1. The Solution

1.2.2. Existence, Uniqueness and Multiplicity of Stationary Equilibria

1.2.3. Linearization and Local Stability of Stationary Equilibria

1.2.4. Global Stability

2. **Multi-Dimensional, Autonomous, First-Order Systems**

2.1. **Linear Systems**

2.1.1. The Solution

2.1.2. Existence and Uniqueness of Stationary Equilibria

2.1.3. Examples of a 2-D System

A. Explicit Solution and Stability Analysis

B. Phase Diagrams

C. Stable and Unstable Manifolds

- 2.1.4. Results from Linear Algebra
- 2.1.5. The Solution in Terms of the Jordan Matrix
- 2.1.6. Stability
 - A. Distinct Real Eigenvalues
 - B. Repeated Real Eigenvalues
 - C. Distinct Pairs of Complex Eigenvalues
 - D. Repeated Pairs of Complex Eigenvalues

2.2. **Nonlinear Systems**

- 2.2.1. Local Analysis
- 2.2.2. Global Analysis

3. **Higher-Order Autonomous Systems**

3.1. **Linear Systems**

- 3.1.1. Second-Order Systems
- 3.1.2. Third-Order Systems
- 3.1.3. N^{th} -Order Systems

3.2. **Nonlinear Systems**

4. **Non-Autonomous Systems**

5. **Exercises**

6. **References**

This manuscript analyzes the fundamental factors that govern the qualitative behavior of discrete dynamical systems. It introduces methods for stability analysis of discrete dynamical systems. The analysis focuses initially on the derivation of basic propositions about the factors that determine the local and global stability of discrete dynamical systems in the elementary context of a one dimensional, first-order systems. These propositions are subsequently generalized to account for stability analysis in a multi-dimensional, higher-order, nonlinear, dynamical systems.

1 One-Dimensional First-Order Systems

This section derives the basic propositions about the factors that determine the local and global stability of discrete dynamical systems in the elementary context of a one dimensional, first-order, autonomous, systems. These basic propositions provide the conceptual foundations for the generalization of the analysis for a multi-dimensional, higher-order, non-autonomous, nonlinear, dynamical systems. The qualitative analysis of the dynamical system is based upon the analysis of the explicit solution of this system. However, once the basic propositions that characterize the behavior of this dynamical system are derived, an explicit solution is no longer required in order to analyze the qualitative behavior of a particular dynamical system of this class.

1.1 Linear Systems

Consider the one-dimensional, autonomous, first-order, linear difference equation

$$y_{t+1} = ay_t + b; \quad t = 0, 1, 2, \dots \infty, \quad (1)$$

where the *state variable* at time t , y_t , is one dimensional, $y_t \in \mathfrak{R}$, the parameters a and b are constant across time (i.e., the dynamical system is autonomous), $a, b \in \mathfrak{R}$,

and the initial value of the state variable at time 0, y_0 , is given.¹

1.1.1 The Solution

A solution to the difference equation $y_{t+1} = ay_t + b$ is a *trajectory* (or an *orbit*), $\{y_t\}_{t=0}^{\infty}$, that satisfies this equation at any point in time. It relates the value of the state variable at time t , y_t , to the initial condition y_0 and to the parameters a and b . The derivation of a solution may follow several methods. In particular, the intuitive method of iterations generates a pattern that can be easily generalized to a solution rule.

Given the value of the state variable at time 0, y_0 , the dynamical system given by (1) implies that

$$\begin{aligned} y_1 &= ay_0 + b; \\ y_2 &= ay_1 + b = a(ay_0 + b) + b = a^2y_0 + ab + b; \\ y_3 &= ay_2 + b = a(a^2y_0 + ab + b) + b = a^3y_0 + a^2b + ab + b; \\ &\vdots \\ y_t &= a^t y_0 + a^{t-1}b + a^{t-2}b + \dots + ab + b \end{aligned} \tag{2}$$

Hence,

$$y_t = a^t y_0 + b \sum_{i=0}^{t-1} a^i.$$

Since $\sum_{i=0}^{t-1} a^i$ is the sum of a geometric series, i.e.,

$$\sum_{i=0}^{t-1} a^i = \frac{1 - a^t}{1 - a} \quad \text{if } a \neq 1,$$

it follows that

¹Without loss of generality, time is truncated to be an element of the set of non-negative integers, and the initial condition is that of the state variable at time 0. In general, t can be defined to be an element of any subset of the set of integers from $-\infty$ to $+\infty$, and the value of the state variable can be given at any point in time.

$$y_t = \begin{cases} a^t y_0 + b \frac{1-a^t}{1-a} & a \neq 1 \\ y_0 + bt & a = 1, \end{cases} \quad (3)$$

or alternatively,

$$y_t = \begin{cases} [y_0 - \frac{b}{1-a}]a^t + \frac{b}{1-a} & \text{if } a \neq 1 \\ y_0 + bt & \text{if } a = 1. \end{cases} \quad (4)$$

Thus, as long as an initial condition of the state variable is given, the trajectory of the dynamical system is uniquely determined. The trajectory derived in equation (4) reveals the qualitative role that the parameters a and (to a lesser extent) b play in the evolution of the state variable over time. As will become apparent, these parameters determine whether the dynamical system evolves monotonically or in oscillations, and whether the state variable diverges, or converges in the long-run to either a stationary state or a periodic orbit.

1.1.2 Existence of Stationary Equilibria

Steady-state equilibria provide an essential reference point for a qualitative analysis of the behavior of dynamical systems. A *steady-state equilibrium* (or alternatively, a *stationary equilibrium*, a *rest point*, an *equilibrium point*, or a *fixed point*) is a value of the state variable y_t that is invariant under further iterations of to the dynamical system. Thus, once the state variable reaches this level it will remain there in the absence of any exogenous perturbations.

Definition 1 A *steady-state equilibrium* of the difference equation $y_{t+1} = ay_t + b$ is a value $\bar{y} \in \mathfrak{R}$, such that

$$\bar{y} = a\bar{y} + b.$$

Following Definition 1, (as depicted in Figures 1.1 - 1.7)

$$\bar{y} = \begin{cases} \frac{b}{1-a} & \text{if } a \neq 1 \\ y_0 & \text{if } a = 1 \text{ \& } b = 0, \end{cases} \quad (5)$$

whereas if $a = 1$ and $b \neq 0$ a steady-state equilibrium does not exist. Thus, the necessary and sufficient conditions for the existence of a steady-state equilibrium are as follows:

Proposition 1 (*Existence of a Steady-State Equilibrium*).

A steady-state equilibrium of the difference equation $y_{t+1} = ay_t + b$ exists if and only if

$$\{a \neq 1\} \text{ or } \{a = 1 \text{ and } b = 0\}.$$

In light of equation (5), the solution to the difference equation derived in (4) can be expressed in terms of the deviations of the initial value of the state variable, y_0 , from its steady-state value, \bar{y} .

$$y_t = \begin{cases} (y_0 - \bar{y})a^t + \bar{y} & \text{if } a \neq 1 \\ y_0 + bt & \text{if } a = 1 \end{cases} \quad (6)$$

1.1.3 Uniqueness of Steady-State Equilibrium

A steady-state equilibrium of a linear dynamical system is not necessarily unique. As depicted in Figures 1.1, 1.2, 1.5, and 1.7, for $a \neq 1$, the steady-state equilibrium is unique, whereas as depicted in Figure 1.3, for $a = 1$ and $b = 0$, a continuum of steady-state equilibria exists and the system remains where it starts. Thus, the necessary and sufficient conditions for the uniqueness of a steady-state equilibrium are as follows:

Proposition 2 (*Uniqueness of a Steady-State Equilibrium*).

A steady-state equilibrium of the difference equation $y_{t+1} = ay_t + b$ is unique if and only if

$$a \neq 1.$$

1.1.4 Stability of Steady-State Equilibria

The stability analysis of steady-state equilibria determines the nature of a steady-state equilibrium (e.g., attractive, repulsive, etc.). It facilitates the study of the local, and often the global, behavior of a dynamical system, and it permits the analysis of the implications of small, and often large, perturbations that occur once the system is in the vicinity of a steady-state equilibrium. If for a sufficiently small perturbation the dynamical system converges asymptotically to the original equilibrium, the system is *locally* stable, whereas if regardless of the magnitude of the perturbation the system converges asymptotically to the original equilibrium, the system is *globally* stable. Formally the definition of local and global stability are as follows:²

Definition 2 A steady-state equilibrium, \bar{y} , of the difference equation $y_{t+1} = ay_t + b$ is:

- *globally (asymptotically) stable, if*

$$\lim_{t \rightarrow \infty} y_t = \bar{y} \quad \forall y_0 \in \mathfrak{R}$$

- *locally (asymptotically) stable, if*

$$\exists \epsilon > 0 \text{ such that } \lim_{t \rightarrow \infty} y_t = \bar{y} \quad \forall y_0 \in B_\epsilon(\bar{y}).^3$$

²The economic literature, to a large extent, refers to the stability concepts in Definition 2 as global stability and local stability, respectively, whereas the mathematical literature refers to them as global asymptotic stability and local asymptotic stability, respectively. The concept of stability in the mathematical literature is reserved to situations in which trajectories that are initiated from an ϵ -neighborhood of a fixed point remains sufficiently close to this fixed point thereafter.

Thus, a steady-state equilibrium is *globally* (asymptotically) stable if the system converges to the steady-state equilibrium regardless of the level of the initial condition, whereas a steady-state equilibrium is *locally* (asymptotically) stable if there exists an ϵ -neighborhood of the steady-state equilibrium such that for every initial condition within this neighborhood the system converges to this steady-state equilibrium.

Global stability of a steady-state equilibrium necessitates the *global uniqueness* of the steady-state equilibrium (i.e., the absence of any additional point in the space from which there is no escape.)

Local stability of a steady-state equilibrium necessitates the *local uniqueness* of the steady-state equilibrium (i.e., the absence of any additional point in the neighborhood of the steady-state from which there is no escape.). Thus if the system is characterized by a continuum of equilibria none of these steady-state equilibrium is locally stable. Local stability requires therefore local uniqueness of the steady-state equilibrium. moreover, if the system is linear local uniqueness implies global uniqueness and local stability necessarily imply global stability.

Corollary 1 *A steady-state equilibrium of $y_{t+1} = ay_t + b$ is globally (asymptotically) stable only if the steady-state equilibrium is unique.*

Following equation (6)

$$\lim_{t \rightarrow \infty} y_t = \begin{cases} [y_0 - \bar{y}] \lim_{t \rightarrow \infty} a^t + \bar{y} & \text{if } a \neq 1; \\ y_0 + b \lim_{t \rightarrow \infty} t & \text{if } a = 1, \end{cases} \quad (7)$$

and therefore

$$\lim_{t \rightarrow \infty} |y_t| = \begin{cases} \bar{y} & \text{if } |a| < 1; \\ y_0 & \text{if } a = 1 \text{ } b = 0; \\ \begin{cases} y_0 & (t = 0, 2, 4, \dots) \\ (b - y_0) & (t = 1, 3, 5, \dots) \end{cases} & \text{if } a = -1; \\ \bar{y} & \text{if } |a| > 1 \text{ \& } y_0 = \bar{y}; \\ \infty & \text{otherwise} \end{cases} \quad (8)$$

Thus, as follows from equation (8):

(a) If $|a| < 1$, then the system is globally (asymptotically) stable converging to the steady-state equilibrium $\bar{y} = b/(1 - a)$ regardless of the initial condition y_0 . In particular, if $a \in (0, 1)$ then the system, as depicted in figure 1.1, is characterized by monotonic convergence, whereas if $a \in (-1, 0)$, then as depicted in Figure 1.2, the convergence is oscillatory.

(b) If $a = 1$ and $b = 0$, the system, as depicted in Figure 1.3, is neither globally nor locally (asymptotically) stable. The system is characterized by a continuum of steady-state equilibria. Each equilibrium can be reached if and only if the system starts at this equilibrium. Thus, the equilibria are (asymptotically) unstable.

(c) If $a = 1$ and $b \neq 0$ the system has no steady-state equilibrium, as shown in Figure 1.4, $\lim_{t \rightarrow \infty} y_t = +\infty$ if $b > 0$ and $\lim_{t \rightarrow \infty} y_t = -\infty$ if $b < 0$.

(d) If $a = -1$, then the system, as depicted in figure 1.5, is characterized by (an asymptotically unstable) two-period cycle,⁷ and the unique steady-state equilibrium, $\bar{y} = b/2$, is (asymptotically) unstable.

⁷Note that definition of stability is perfectly applicable for periodic orbits, provided that the dynamical system is redefined to be the n^{th} iterate of the original one, and n is the periodicity of the cycle.

(e) If $|a| > 1$ then the system, as depicted in Figures 1.6 and 1.7, is unstable. For $y_0 \neq b/(1 - a)$, $\lim_{t \rightarrow \infty} |y_t| = \infty$, whereas for $y_0 = b/(1 - a)$ the system starts at the steady-state equilibrium where it remains thereafter. Every minor perturbation, however, causes the system to step on a diverging path. If $a > 1$ the divergence is monotonic whereas if $a < -1$ the divergence is oscillatory.

Thus the following Proposition can be derived from equation (8) and the subsequent analysis.

Proposition 3 (*A Necessary and Sufficient Condition for Global Stability*)

A steady-state equilibrium of the difference equation $y_{t+1} = ay_t + b$ is globally stable if and only if

$$|a| < 1.$$

Corollary 2 *For any $y_0 \neq \bar{y}$,*

$$\lim_{t \rightarrow \infty} y_t = \bar{y} \quad \text{if } |a| < 1.$$

Convergence is monotonic if $0 < a < 1$

Convergence is oscillatory if $-1 < a < 0$.

1.2 Nonlinear Systems

Consider the one-dimensional first-order nonlinear equation

$$y_{t+1} = f(y_t); \quad t = 0, 1, 2, \dots, \infty, \tag{9}$$

where $f : \mathfrak{R} \rightarrow \mathfrak{R}$ is a differentiable single-valued function and the initial value of the state variable, y_0 , is given.

1.2.1 The Solution

Using the method of iterations, the trajectory of this nonlinear system, $\{y_t\}_{t=0}^{\infty}$, can be written as follows:

$$\begin{aligned}y_1 &= f(y_0); \\y_2 &= f(y_1) = f[f(y_0)] \equiv f^{(2)}(y_0); \\&\vdots \\y_t &= f^{(t)}(y_0).\end{aligned}\tag{10}$$

Unlike the solution to the linear system (1), the solution for the nonlinear system (10) is not very informative. Hence, additional methods of analysis are required in order to gain an insight about the qualitative behavior of this nonlinear system. In particular, a local approximation of the nonlinear system by a linear one is instrumental in the study of the qualitative behavior of nonlinear dynamical systems.

1.2.2 Existence, Uniqueness and Multiplicity of Stationary Equilibria

Definition 3 *A steady-state equilibrium of the difference equation $y_{t+1} = f(y_t)$ is a level $\bar{y} \in \Re$ such that*

$$\bar{y} = f(\bar{y}).$$

Generically, a nonlinear system may be characterized by either the existence of a unique steady-state equilibrium, the non-existence of a steady-state equilibrium, or the existence of a multiplicity of (distinct) steady-state equilibria. Figure 1.8 depicts a system with a globally stable unique steady-state equilibrium, whereas Figure 1.9 depicts a system with multiple distinct steady-state equilibria.

1.2.3 Linearization and Local Stability of Steady-State Equilibria

The behavior of a nonlinear system around a steady-state equilibrium, \bar{y} , can be approximated by a linear system. Consider the Taylor expansion of $y_{t+1} = f(y_t)$ around \bar{y} . Namely,

$$y_{t+1} = f(y_t) = f(\bar{y}) + f'(\bar{y})(y_t - \bar{y}) + \frac{f''(\bar{y})(y_t - \bar{y})^2}{2!} + \cdots + R_n. \quad (11)$$

The linearized system around the steady-state equilibrium \bar{y} is therefore

$$\begin{aligned} y_{t+1} &= f(\bar{y}) + f'(\bar{y})(y_t - \bar{y}) \\ &= f'(\bar{y})y_t + f(\bar{y}) - f'(\bar{y})\bar{y} \\ &= ay_t + b, \end{aligned} \quad (12)$$

where, $a \equiv f'(\bar{y})$ and $b \equiv f(\bar{y}) - f'(\bar{y})\bar{y}$ are given constants.

Applying the stability results established for the linear system, the linearized system is globally stable if $|a| \equiv |f'(\bar{y})| < 1$. However, since the linear system approximates the behavior of the nonlinear system only in a neighborhood of a steady-state equilibrium, the global stability of the linearized system implies only the local stability of the nonlinear difference equation. Thus, the following Proposition is established:

Proposition 4 *The dynamical system $y_{t+1} = f(y_t)$ is locally stable around steady-state equilibrium \bar{y} , if and only if*

$$\left| \frac{dy_{t+1}}{dy_t} \Big|_{\bar{y}} \right| < 1.$$

Consider Figure 1.9 where the dynamical system is characterized by four steady-state equilibria. $f'(\bar{y}_1) < 1$ and $f'(\bar{y}_3) < 1$, and consequently \bar{y}_1 and \bar{y}_3 are locally stable steady-state equilibria, whereas, $f'(0) > 1$ and $f'(\bar{y}_2) > 1$, and consequently 0 and \bar{y}_2 are unstable steady-state equilibria.

1.2.4 Global Stability

The Contraction Mapping Theorem provides a useful set of sufficient conditions for the existence of a unique steady-state equilibrium and its global stability. These conditions, however, are overly restrictive.

Definition 4 Let (S, ρ) be a metric space and let $T : S \rightarrow S$. T is a contraction mapping if for some $\beta \in (0, 1)$,

$$\rho(Tx, Ty) \leq \beta\rho(x, y) \quad \forall x, y \in S.$$

Lemma 1 (*The Contraction Mapping Theorem*) If (S, ρ) is a complete metric space and $T : S \rightarrow S$ is a contraction mapping then

- T has a single fixed point (i.e., there exists a unique v such that $Tv = v$).
- $\forall v_0 \in S$ and for $\beta \in (0, 1)$, $\rho(T^n v_0, v) \leq \beta^n \rho(v_0, v) \quad \forall n = 1, 2, 3, \dots$.

Corollary 3 A stationary equilibrium of the difference equation $y_{t+1} = f(y_t)$ exists and is unique and globally (asymptotically) stable if $f : R \rightarrow R$ is a contraction mapping, i.e., if

$$\frac{|f(y_{t+1}) - f(y_t)|}{|y_{t+1} - y_t|} < 1 \quad \forall t = 0, 1, 2, \dots, \infty,$$

or if $f \in C^1$ and

$$f'(y_t) < 1 \quad \forall t = 0, 1, 2, \dots, \infty.$$

Thus, if over the entire domain the derivative of $f(y_t)$ is smaller than unity in absolute value, the map $f(y_t)$ has a unique and globally stable steady-state equilibrium.

2 Multi-Dimensional First-Order Systems

2.1 Linear Systems

Consider a system of autonomous, first-order, linear difference equations

$$x_{t+1} = Ax_t + B, \quad t = 0, 1, 2, \dots, \infty, \quad (13)$$

where the state variable x_t is an n -dimensional vector; $x_t \in \mathfrak{R}^n$, A is an $n \times n$ matrix of parameters which are constant across time; $A = (a_{ij})$, $a_{ij} \in \mathfrak{R}$, $\forall i, j = 1, 2, \dots, n$, and B is a n dimensional column vector of constant parameters; $B \in \mathfrak{R}^n$. The initial value of the state variable x_0 is given.

2.1.1 The Solution

A solution to the multi-dimensional linear system $x_{t+1} = Ax_t + B$ is a trajectory $\{x_t\}_{t=0}^{\infty}$ of the vector x_t that satisfies this equation at any point in time and relates the value of the state variable at time t , x_t to the initial condition x_0 and the set of parameters embodied in the vector B and the matrix A . Given the value of the state variable at time 0, x_0 , the method of iterations generates a pattern that constitutes a general solution.

$$\begin{aligned} x_1 &= Ax_0 + B; \\ x_2 &= Ax_1 + B = A(Ax_0 + B) + B = A^2x_0 + AB + B; \\ x_3 &= Ax_2 + B = A(A^2x_0 + AB + B) + B = A^3x_0 + A^2B + AB + B; \\ &\vdots \\ x_t &= A^t x_0 + A^{t-1}B + A^{t-2}B + \dots + AB + B \\ &= A^t x_0 + \sum_{i=0}^{t-1} A^i B. \end{aligned} \quad (14)$$

Unlike the one-dimensional case, the solution depends on the sum of a geometric series of matrices rather than of scalars.

Lemma 2

$$\sum_{i=0}^{t-1} A^i = [I - A^t][I - A]^{-1} \quad \text{if} \quad |I - A| \neq 0.$$

Proof. Since

$$\sum_{i=0}^{t-1} A^i [I - A] = I + A + A^2 + \dots + A^{t-1} - [A + A^2 + A^3 + \dots + A^t] = I - A^t.$$

Post-multiplication of both sides of the equation by the matrix $[I - A]^{-1}$ establishes the lemma, noting that $[I - A]^{-1}$ exists if and only if $|I - A| \neq 0$. \square

Using the result in Lemma 2 it follows that

$$x_t = A^t[x_0 - [I - A]^{-1}B] + [I - A]^{-1}B \quad \text{if} \quad |I - A| \neq 0. \quad (15)$$

Thus, the value of the state variable at time t , x_t depends on the initial condition x_0 and the set of parameters embodied in the vector B and the matrix A . As will become apparent, the qualitative aspects of the the dynamical system will be determined by the parameters of the matrix A .

2.1.2 Existence and Uniqueness of Stationary Equilibria

The qualitative analysis of the dynamical systems can be examined in relation to a steady-state equilibrium of the system. A *steady-state equilibrium* of this n-dimensional system is a value of the n-dimensional vector the state variable x_t that is invariant under further iterations of to the dynamical system. Thus, once each of the state variables reaches its steady-state level, the system will not evolve in the absence of exogenous perturbations.

Definition 5 A steady-state equilibrium of a system of difference equations $x_{t+1} = Ax_t + B$ is a vector $\bar{x} \in \mathfrak{R}^n$ such that

$$\bar{x} = A\bar{x} + B.$$

Following the Definition, in analogy to the analysis of the one-dimensional system, there exists a unique steady-state equilibrium

$$\bar{x} = [I - A]^{-1}B \quad \text{if} \quad |I - A| \neq 0. \quad (16)$$

Analogous to Proposition 2, the following result concerning the uniqueness of steady-state equilibrium holds:

Proposition 5 A steady-state equilibrium of the system $x_{t+1} = Ax_t + B$ is unique if and only if

$$|I - A| \neq 0.$$

Remark 1 The necessary and sufficient condition for uniqueness is the non-singularity of the matrix $I - A$. It is analogous to the requirement that $a \neq 1$ in the one-dimensional case.

In light of (16), the solution to the system can be written as

$$x_t = A^t(x_0 - \bar{x}) + \bar{x} \quad \text{if} \quad |I - A| \neq 0. \quad (17)$$

If the matrix A is a diagonal matrix there exists no interdependence between the different state variables and each of the state variables can be analyzed separately according to the method developed in Section 1.1. However, a more general form of the matrix A , which implies interdependence across the state variables, requires an elaborate method of solutions. This method transforms a system of interdependent state variables, into a system of independent state variables that can be analyzed according to the method developed in Section 1.1.

2.1.3 Examples of a 2-D Systems:

The following examples demonstrate the method of solution that will be adopted in the case of multi-dimensional dynamical systems. This method is formally derived in subsequent subsections.

A. Explicit Solution and Stability Analysis

Example 1: (An Uncoupled System)

Consider the two-dimensional, first-order, homogeneous difference equation⁸

$$\begin{bmatrix} x_{1t+1} \\ x_{2t+1} \end{bmatrix} = \begin{bmatrix} 2 & 0 \\ 0 & 0.5 \end{bmatrix} \begin{bmatrix} x_{1t} \\ x_{2t} \end{bmatrix}, \quad (18)$$

where $x_0 \equiv [x_{10}, x_{20}]$.

Since x_{1t+1} depends only on x_{1t} , and x_{2t+1} only on x_{2t} the system can be uncoupled and each equation can be solved in isolation using the solution method developed in Section 1.1. Given that

$$\begin{aligned} x_{1t+1} &= 2x_{1t}; \\ x_{2t+1} &= 0.5x_{2t} \end{aligned} \quad (19)$$

it follows from (4) that

$$\begin{aligned} x_{1t} &= 2^t x_{10}; \\ x_{2t} &= (0.5)^t x_{20}. \end{aligned} \quad (20)$$

and the steady-state equilibrium is therefore

$$(\bar{x}_1, \bar{x}_2) = (0, 0). \quad (21)$$

Consequently,

$$\lim_{t \rightarrow \infty} x_{2t} = \bar{x}_2 = 0 \quad \forall x_{20} \in \Re \quad (22)$$

If $x_{20} > 0$, the value of x_{2t} approaches zero monotonically from the positive side, and, if $x_{20} < 0$, it approaches the origin monotonically from the negative side. Furthermore

⁸The linear system $x_{t+1} = Ax_t$ is homogeneous whereas the system $x_{t+1} = Ax_t + B$ is non-homogeneous.

$$\lim_{t \rightarrow \infty} x_{1t} = \begin{cases} \pm\infty & \text{if } x_{10} \neq 0; \\ \bar{x}_1 = 0 & \text{if } x_{10} = 0. \end{cases} \quad (23)$$

Namely, unless the initial condition of state variable x_{1t} is at its steady state value $\bar{x}_1 = 0$, the variable diverges monotonically to $+\infty$, if $x_{10} > 0$ and to $-\infty$ if $x_{10} < 0$.

Figure 2.1, depicts the phase diagram for this *discrete* dynamical system. The steady-state equilibrium (i.e., $(\bar{x}_1, \bar{x}_2) = (0, 0)$) is a saddle point.⁹ Namely, unless $x_{10} = 0$, the steady-state equilibrium will not be reached and the system will diverge.

Example 2: (A Coupled System)

Consider the coupled dynamical system

$$\begin{bmatrix} x_{1t+1} \\ x_{2t+1} \end{bmatrix} = \begin{bmatrix} 1 & 0.5 \\ 1 & 1.5 \end{bmatrix} \begin{bmatrix} x_{1t} \\ x_{2t} \end{bmatrix}, \quad (24)$$

where $x_0 \equiv [x_{10}, x_{20}]$ is given.

The system cannot be uncoupled since the two variables x_{1t} and x_{2t} are interdependent. Thus a different solution method is required.

The solution technique converts the coupled system (via a time-invariant matrix) into a new system of coordinates in which the dynamical system is uncoupled and therefore solvable with the method of analysis described in Section 1.1.

The following steps, based on foundations that are discussed in the next subsections, constitute the required method of solution:

Fin

Step 1: Find the Eigenvalues of the matrix of coefficients A .

The Eigenvalues of the matrix A are obtained as a solution to the system

$$|A - \lambda I| = 0. \quad (25)$$

⁹Note that for ease of visualization, the trajectories are drawn in a continuous manner. The trajectories, however, consist of discrete points.

$$\begin{vmatrix} a_{11} - \lambda & a_{21} \\ a_{12} & a_{22} - \lambda \end{vmatrix} = 0$$

The implied characteristic polynomial is therefore

$$C(\lambda) = \lambda^2 - \text{tr}A\lambda + \det A = 0. \quad (26)$$

Given the dimensionality of the matrix A , it follows that

$$\begin{cases} \lambda_1 + \lambda_2 = \text{tr}A \\ \lambda_1\lambda_2 = \det A. \end{cases} \quad (27)$$

In light of (24), $\lambda_1 + \lambda_2 = 2.5$, and $\lambda_1\lambda_2 = 1$. This implies that $\lambda_1 = 2$ and $\lambda_2 = 0.5$.

Step 2: Find the eigenvector associated with λ_1 and λ_2 .

The eigenvectors of the matrix A are obtained as a solution to the system

$$[A - \lambda I]x = 0 \text{ for } x \neq 0. \quad (28)$$

Hence, it follows from (24) that the eigenvector associated with the eigenvalue $\lambda_1 = 2$ is determined by

$$\begin{bmatrix} -1 & 0.5 \\ 1 & -0.5 \end{bmatrix} \begin{bmatrix} x_1 \\ x_2 \end{bmatrix} = 0, \quad (29)$$

whereas that associated with $\lambda_2 = 0.5$ is determined by

$$\begin{bmatrix} 0.5 & 0.5 \\ 1 & 1 \end{bmatrix} \begin{bmatrix} x_1 \\ x_2 \end{bmatrix} = 0. \quad (30)$$

Thus the first eigenvector is determined by the equation

$$x_2 = 2x_1, \quad (31)$$

whereas the second eigenvector is given by the equation

$$x_2 = -x_1. \quad (32)$$

The eigenvectors are therefore given by f_1 and f_2 (or any scalar multiplication of the two): $f_1 = (1, 2)$ and $f_2 = (1, -1)$.

Step 3: Use the basis $[f_1, f_2]$ to span \mathfrak{R}^2 (i.e., construct a new system of coordinates that spans \mathfrak{R}^2).

Since f_1 and f_2 span \mathfrak{R}^2 , $\exists y \equiv (y_1, y_2) \in \mathfrak{R}^2$ such that

$$\begin{bmatrix} x_1 \\ x_2 \end{bmatrix} = y_1 f_1 + y_2 f_2 = y_1 \begin{bmatrix} 1 \\ 2 \end{bmatrix} + y_2 \begin{bmatrix} 1 \\ -1 \end{bmatrix}. \quad (33)$$

Thus,

$$x \equiv \begin{bmatrix} x_1 \\ x_2 \end{bmatrix} = \begin{bmatrix} 1 & 1 \\ 2 & -1 \end{bmatrix} \begin{bmatrix} y_1 \\ y_2 \end{bmatrix} \equiv Qy. \quad (34)$$

Namely, every $x \in \mathfrak{R}^2$ can be expressed in terms of the new system of coordinates, (y_1, y_2) .

Step 4: Find the geometric place of the new system of coordinates in (y_1, y_2) in terms of the old system of coordinates (x_1, x_2) .

Since f_1 and f_2 are linearly independent, Q is non-singular and thus Q^{-1} exists. Hence, $y = Q^{-1}x$, i.e.,

$$\begin{bmatrix} y_1 \\ y_2 \end{bmatrix} = -\frac{1}{3} \begin{bmatrix} -1 & -1 \\ -2 & 1 \end{bmatrix} \begin{bmatrix} x_1 \\ x_2 \end{bmatrix} \quad (35)$$

and therefore,

$$\begin{aligned} y_1 &= \frac{1}{3}(x_1 + x_2); \\ y_2 &= \frac{1}{3}(2x_1 - x_2). \end{aligned} \quad (36)$$

Thus,

$$\begin{aligned} y_1 = 0 &\Leftrightarrow x_2 = -x_1 \\ y_2 = 0 &\Leftrightarrow x_2 = 2x_1 \end{aligned} \quad (37)$$

Graphically, as shown in Figure 2.2, since $y_1 = 0$ implies being on the y_2 axis, and $y_2 = 0$ implies being on the y_1 axis, $x_2 = 2x_1$ represents the y_1 axis in the new system of coordinates and $x_2 = -x_1$ represents the y_2 axis in the new system of coordinates.

Step 5: Show that there exists a 2x2 matrix D , such that $y_{t+1} = Dy_t$.

In the original system,

$$x_{t+1} = Ax_t. \quad (38)$$

As follows from Step 3,

$$x_{t+1} = Qy_{t+1} \quad (39)$$

Thus,

$$\begin{aligned} y_{t+1} &= Q^{-1}x_{t+1} \\ &= Q^{-1}Ax_t \quad (\text{since } x_{t+1} = Ax_t) \\ &= Q^{-1}AQy_t \quad (\text{since } x_t = Qy_t) \\ &= Dy_t, \end{aligned} \quad (40)$$

where $D \equiv Q^{-1}AQ$.

Step 6: Show that D is a diagonal matrix with the Eigenvalues of A along the diagonal.

$$D = Q^{-1}AQ = -\frac{1}{3} \begin{bmatrix} -1 & -1 \\ -2 & 1 \end{bmatrix} \begin{bmatrix} 1 & 0.5 \\ 1 & 1.5 \end{bmatrix} \begin{bmatrix} 1 & 1 \\ 2 & -1 \end{bmatrix} = \begin{bmatrix} 2 & 0 \\ 0 & 0.5 \end{bmatrix} \quad (41)$$

Since $\lambda_1 = 2$ and $\lambda_2 = 0.5$, it follows that D is a diagonal matrix of the type:

$$D = \begin{bmatrix} \lambda_1 & 0 \\ 0 & \lambda_2 \end{bmatrix}. \quad (42)$$

Step 7: Find the solution for y_t .

$$y_{t+1} = \begin{bmatrix} 2 & 0 \\ 0 & 0.5 \end{bmatrix} y_t. \quad (43)$$

Since the system is uncoupled, it follows from example 1 that

$$\begin{aligned} y_{1t} &= 2^t y_{10} \\ y_{2t} &= (0.5)^t y_{20} \end{aligned} \quad (44)$$

Note that y_0 is not given directly. However, since $y_0 = Q^{-1}x_0$, and x_0 is given, y_0 can be expressed in terms of x_0 .

$$\begin{bmatrix} y_{10} \\ y_{20} \end{bmatrix} = Q^{-1}x_0 = -\frac{1}{3} \begin{bmatrix} -1 & -1 \\ -2 & 1 \end{bmatrix} \begin{bmatrix} x_{10} \\ x_{20} \end{bmatrix} \quad (45)$$

Thus

$$\begin{aligned} y_{10} &= \frac{1}{3}(x_{10} + x_{20}) \\ y_{20} &= \frac{1}{3}(2x_{10} - x_{20}) \end{aligned} \quad (46)$$

Step 8: Draw the phase diagram of the new system.

The new system $y_{t+1} = Dy_t$ is precisely the system examined in example 1. Consequently, there exists a unique steady-state equilibrium $\bar{y} = (0, 0)$ that is a saddle-point. Figure 2.1 provide the phase diagram of this system.

Step 9: Find the solution for x_t .

Since $x_t = Qy_t$, it follows from (44) that

$$\begin{bmatrix} x_{1t} \\ x_{2t} \end{bmatrix} = \begin{bmatrix} 1 & 1 \\ 2 & -1 \end{bmatrix} \begin{bmatrix} y_{1t} \\ y_{2t} \end{bmatrix} = \begin{bmatrix} 1 & 1 \\ 2 & -1 \end{bmatrix} \begin{bmatrix} 2^t y_{10} \\ (0.5)^t y_{20} \end{bmatrix} \quad (47)$$

$$= \begin{bmatrix} 2^t y_{10} + (0.5)^t y_{20} \\ 2^{t+1} y_{10} - (0.5)^t y_{20} \end{bmatrix} \quad (48)$$

where $y_0 = Q^{-1}x_0$ is given by (46).

Step 10: Examine the stability of the steady-state equilibrium.

Following (47) $\lim_{t \rightarrow \infty} x_t = \bar{x} = 0$ if and only if $y_{10} = 0$. Thus, in light of the value of y_{10} given by (46)

$$\lim_{t \rightarrow \infty} x_t = \bar{x} \Leftrightarrow x_{20} = -x_{10} \quad (49)$$

and the steady-state equilibrium $\bar{x} = 0$ is a saddle point.

Step 11: Draw the phase diagram of the original system.

Consider Figure 2.2. The phase diagram of the original system is obtained by placing the new coordinates (y_1, y_2) in the plane (x_1, x_2) and drawing the phase diagram of the new system relative to the coordinates, (y_1, y_2) .

B. Phase Diagrams

The derivation of the phase diagram of these two dimensional systems does not require an explicit solution of the system of equations. One can generate the amp of forces that operate on the state variables in any position in the relevant plain, as a function of deviations from each state variable from its steady-state value.

Consider Example 2 where

$$\begin{bmatrix} x_{1t+1} \\ x_{2t+1} \end{bmatrix} = \begin{bmatrix} 1 & 0.5 \\ 1 & 1.5 \end{bmatrix} \begin{bmatrix} x_{1t} \\ x_{2t} \end{bmatrix}. \quad (50)$$

The system can be rewritten in a slightly different manner, i.e., in terms of changes in the values of the state variables between time t and time $t + 1$:

$$\begin{aligned} \Delta x_{1t} &\equiv x_{1t+1} - x_{1t} = 0.5x_{2t} \\ \Delta x_{2t} &\equiv x_{2t+1} - x_{2t} = x_{1t} + 0.5x_{2t}. \end{aligned} \quad (51)$$

Clearly, at a steady-state equilibrium, $\Delta x_{1t} = \Delta x_{2t} = 0$.

Let ‘ $\Delta x_{1t} = 0$ ’ be the geometric place of all pairs of x_{1t} and x_{2t} such that x_{1t} is in a steady-state, and let ‘ $\Delta x_{2t} = 0$ ’ be the geometric place of all pairs (x_{1t}, x_{2t}) such that x_{2t} is in a steady state. Namely,

$$\begin{aligned}\Delta x_{1t} = 0 &\equiv \{(x_{1t}, x_{2t}) | x_{1t+1} - x_{1t} = 0\} \\ \Delta x_{2t} = 0 &\equiv \{(x_{1t}, x_{2t}) | x_{2t+1} - x_{2t} = 0\}.\end{aligned}\tag{52}$$

It follows from equations (51) and (52) that

$$\Delta x_{1t} = 0 \Leftrightarrow x_{2t} = 0.\tag{53}$$

$$\Delta x_{2t} = 0 \Leftrightarrow x_{2t} = -2x_{1t}.$$

Thus, as depicted in Figure 2.3, the geometric locus of $\Delta x_{1t} = 0$ is the entire x_{1t} axis, whereas that of $\Delta x_{2t} = 0$ is given by the equation $x_{2t} = -2x_{1t}$.

The two loci intersect at the origin (the unique steady-state equilibrium) where $\Delta x_{1t} = \Delta x_{2t} = 0$. In addition

$$\Delta x_{1t} = \begin{cases} > 0 & \text{if } x_{2t} > 0 \\ < 0 & \text{if } x_{2t} < 0, \end{cases}\tag{54}$$

and

$$\Delta x_{2t} = \begin{cases} > 0 & \text{if } x_{2t} > -2x_{1t} \\ < 0 & \text{if } x_{2t} < -2x_{1t}. \end{cases}\tag{55}$$

Since both Eigenvalues are real and positive, the qualitative nature of the dynamical system can be determined on the basis of the information provided in equations (53) – (55). The system is depicted in Figure 2.3 according to the location of the loci ‘ $\Delta x_{1t} = 0$ ’ and ‘ $\Delta x_{2t} = 0$,’ as well as the corresponding arrows of motion.

Remark. Since the dynamical system is discrete, a phase diagram should not be drawn before the type of the eigenvalues is verified. If both eigenvalues are real and positive,

each state variable converges or diverges monotonically. However, if an eigenvalue is negative, then the dynamical system displays an oscillatory behavior, whereas if the eigenvalues are complex, then the dynamical system exhibits a cyclical motion. The arrows of motion in discrete systems can be very misleading and should, therefore, be handled very carefully.

The exact location of the new system of coordinates can be determined as well. If the steady-state equilibrium is a saddle, convergence to the steady-state equilibrium is along a linear segment. Thus,

$$\frac{x_{2t+1}}{x_{1t+1}} = \frac{x_{2t}}{x_{1t}}, \quad (56)$$

along this particular segment. Hence, in light of equation (50),

$$\frac{x_{1t} + 1.5x_{2t}}{x_{1t} + 0.5x_{2t}} = \frac{x_{2t}}{x_{1t}}, \quad (57)$$

or

$$\left(\frac{x_{2t}}{x_{1t}} \right)^2 - \left(\frac{x_{2t}}{x_{1t}} \right) - 2 = 0.$$

The solutions are therefore $\frac{x_{2t}}{x_{1t}} = [2, -1]$. These two solutions to this quadratic equation are the eigenvectors of the matrix A . They are the two constant ratios that lead into the steady-state equilibrium upon a sufficient number of either forward or backward iterations.

Thus, substantial information about the qualitative nature of the phase diagram of the dynamical system may be obtained without an explicit solution of the system.

C. Stable and Unstable Eigenspaces

The examples above provide an ideal setting for the introduction of the concepts of a *stable eigenspace* and an *unstable eigenspace* that set the stage for the introduction of the concepts of the stable and unstable manifolds in the context of nonlinear dynamical systems. In a linear system the stable eigenspace relative to the steady-state equilibrium \bar{x} , is defined as the the plain span by the eigenvectors that are associated with eigen values of modulus smaller than one. Namely,

$E^s(\bar{x}) = \text{span} \{ \text{eigenvectors associate with eigenvalues of modulus smaller than } 1 \}.$

In an homogenous two-dimensional autonomous linear system, $x_{t+1} = Ax_t$, the eigenspace is

$$E^s(\bar{x}) = \{ (x_{1t}, x_{2t}) \mid \lim_{n \rightarrow \infty} A^n \begin{pmatrix} x_{1t} \\ x_{2t} \end{pmatrix} = \bar{x} \}. \quad (58)$$

Namely, the *stable eigenspace* is the geometric locus of all pairs (x_{1t}, x_{2t}) that upon a sufficient number of forward iterations are mapped in the limit towards the steady-state equilibrium, \bar{x} . The stable eigenspace in the above example is one dimensional. It is a linear curve given by the equation $x_{2t} = -x_{1t}$.

The *unstable eigenspace* relative to the steady-state equilibrium \bar{x} , is defined as

$E^u(\bar{x}) = \text{span} \{ \text{eigenvectors associate with eigenvalues are of modulus greater than } 1 \}.$

In an homogeneous two-dimensional linear system, $x_{t+1} = Ax_t$,

$$E^u(\bar{x}) = \{ (x_{1t}, x_{2t}) \mid \lim_{n \rightarrow \infty} A^{-n} \begin{pmatrix} x_{1t} \\ x_{2t} \end{pmatrix} = \bar{x} \}. \quad (59)$$

That is, the geometric locus of all pairs (x_{1t}, x_{2t}) that upon a sufficient number of backward iterations are mapped in the limit to the steady-state equilibrium. The unstable eigenspace in the above example is one dimensional as well. It is a linear locus given by the equation $x_{2t} = 2x_{1t}$.

2.1.4 Results From Linear Algebra

Lemma 3 Let $A = (a_{ij})$ be an $n \times n$ matrix where $a_{ij} \in \mathfrak{R}$, $i, j = 1, 2, \dots, n$.

- If the matrix A has n distinct real eigenvalues $\lambda_1, \lambda_2, \dots, \lambda_n$, then there exists a nonsingular $n \times n$ matrix, Q , such that

$$A = QDQ^{-1},$$

where D is a diagonalized matrix

$$D = \begin{bmatrix} \lambda_1 & 0 & 0 & 0 & \dots & 0 \\ 0 & \lambda_2 & 0 & 0 & \dots & 0 \\ 0 & 0 & \lambda_3 & 0 & \dots & 0 \\ 0 & 0 & 0 & \lambda_4 & \dots & 0 \\ \vdots & \vdots & \vdots & \vdots & \ddots & \vdots \\ 0 & 0 & 0 & 0 & \dots & \lambda_n \end{bmatrix},$$

and Q is a $n \times n$ matrix whose columns are the eigenvectors of A .

- If the matrix A has n repeated real eigenvalues $\lambda, \lambda, \dots, \lambda$, then there exists a nonsingular $n \times n$ matrix, Q , such that

$$A = QDQ^{-1},$$

where

$$D = \begin{bmatrix} \lambda & 0 & 0 & 0 & 0 & 0 & 0 & 0 \\ 1 & \lambda & 0 & 0 & 0 & 0 & 0 & 0 \\ 0 & 1 & \lambda & 0 & 0 & 0 & 0 & 0 \\ 0 & 0 & 1 & \lambda & 0 & 0 & 0 & 0 \\ 0 & 0 & 0 & 1 & \lambda & 0 & 0 & 0 \\ 0 & 0 & 0 & 0 & 1 & \lambda & 0 & 0 \\ 0 & 0 & 0 & 0 & 0 & 1 & \lambda & 0 \\ 0 & 0 & 0 & 0 & 0 & 0 & 1 & \lambda \end{bmatrix}$$

Lemma 4 • If a matrix has $n/2$ pairs of distinct complex eigenvalues, $\mu_1, \bar{\mu}_1, \mu_2, \bar{\mu}_2, \dots, \mu_{n/2}, \bar{\mu}_{n/2}$, where $\mu_j \equiv \alpha_j + \beta_j i$, $\bar{\mu}_j \equiv \alpha_j - \beta_j i$, ($i \equiv \sqrt{-1}$), then there exists a nonsingular $n \times n$ matrix, Q , such that

$$A = QDQ^{-1},$$

where

•

$$D = \begin{bmatrix} \alpha_1 & -\beta_1 & 0 & 0 & \dots & \dots & 0 & 0 \\ \beta_1 & \alpha_1 & 0 & 0 & \dots & \dots & 0 & 0 \\ 0 & 0 & \alpha_2 & -\beta_2 & \dots & \dots & 0 & 0 \\ 0 & 0 & \beta_2 & \alpha_2 & \dots & \dots & 0 & 0 \\ & & & & \ddots & \ddots & 0 & 0 \\ & & & & \ddots & \ddots & 0 & 0 \\ 0 & 0 & 0 & 0 & \dots & \dots & \alpha_{n/2} & -\beta_{n/2} \\ 0 & 0 & 0 & 0 & \dots & \dots & \beta_{n/2} & \alpha_{n/2} \end{bmatrix}$$

- If a matrix A has $n/2$ pairs of repeated complex eigenvalues, $\mu, \bar{\mu}, \mu, \bar{\mu}, \dots, \mu, \bar{\mu}$, where $\mu \equiv \alpha + \beta i$, $\bar{\mu} \equiv \alpha - \beta i$, ($i \equiv \sqrt{-1}$), then there exists a nonsingular $n \times n$ matrix Q such that $A = QDQ^{-1}$, where

$$D = \begin{bmatrix} \alpha & -\beta & 0 & 0 & 0 & 0 & 0 & 0 & 0 & 0 \\ \beta & \alpha & 0 & 0 & 0 & 0 & 0 & 0 & 0 & 0 \\ 1 & 0 & \alpha & -\beta & 0 & 0 & 0 & 0 & 0 & 0 \\ 0 & 1 & \beta & \alpha & 0 & 0 & 0 & 0 & 0 & 0 \\ 0 & 0 & 1 & 0 & \alpha & -\beta & 0 & 0 & 0 & 0 \\ 0 & 0 & 0 & 1 & \beta & \alpha & 0 & 0 & 0 & 0 \\ 0 & 0 & 0 & 0 & 1 & 0 & \alpha & -\beta & 0 & 0 \\ 0 & 0 & 0 & 0 & 0 & 1 & \beta & \alpha & 0 & 0 \\ 0 & 0 & 0 & 0 & 0 & 0 & 1 & 0 & \alpha & -\beta \\ 0 & 0 & 0 & 0 & 0 & 0 & 0 & 1 & \beta & \alpha \end{bmatrix}$$

.

Proof: By definition of an eigenvector of an $n \times n$ matrix A , it is a non-zero vector $x \in \mathfrak{R}^n$, such that $Ax = x\lambda$, $\forall \lambda \in \mathfrak{R}$. Namely,

$$\begin{aligned} Ax_1 &= \lambda_1 x_1, \\ Ax_2 &= \lambda_2 x_2, \\ &\vdots \\ Ax_n &= \lambda_n x_n. \end{aligned}$$

Let $Q = [x_1, x_2, x_3, \dots, x_n]$ and let $D = [\lambda_1, \lambda_2, \dots, \lambda_n]I$. It follows that

$$AQ = QD$$

and consequently,

$$A = QDQ^{-1}.$$

See Hirsch and Smale (1974) for proofs of the remaining results. \square

Lemma 5 *Let A be an $n \times n$ matrix where $a_{ij} \in \mathfrak{R}$, $i, j = 1, 2, \dots, n$. Then, there exists an $n \times n$ nonsingular matrix Q such that $A = QDQ^{-1}$, where*

•

$$D = \begin{bmatrix} D_1 & 0 & 0 & \dots & 0 & 0 \\ 0 & D_2 & 0 & \ddots & 0 & 0 \\ 0 & 0 & D_3 & \ddots & 0 & 0 \\ 0 & 0 & 0 & \ddots & 0 & 0 \\ 0 & 0 & 0 & \ddots & 0 & 0 \\ 0 & 0 & 0 & \dots & 0 & D_m \end{bmatrix},$$

is the Jordan matrix.

• *For distinct real eigenvalues:*

$$D_h = \lambda_h,$$

• *For repeated eigenvalues:*

$$D_h = \begin{bmatrix} \lambda & & & 0 \\ 1 & \lambda & & \\ & 1 & \ddots & \\ 0 & \ddots & 1 & \lambda \end{bmatrix},$$

• *For distinct complex eigenvalues:*

$$D_h = \begin{bmatrix} \alpha_h & -\beta_h \\ \beta_h & \alpha_h \end{bmatrix},$$

Hence, since $\bar{x} = [I - A]^{-1}B$,

$$z_{t+1} = Az_t.$$

□

Thus, the non-homogeneous system is transformed into a homogenous one by shifting the origin of the non-homogeneous system to the steady-state equilibrium.

Proposition 7 *The solution of a system of non-homogeneous first-order linear difference equations*

$$x_{t+1} = Ax_t + B$$

is

$$x_t = QD^tQ^{-1}(x_0 - \bar{x}) + \bar{x},$$

where D is the Jordan matrix corresponding to A .

Proof: Let $z_t \equiv x_t - \bar{x}$. It follows from the Lemma 5 and Proposition 6 that

$$z_{t+1} = Az_t,$$

where $A = QDQ^{-1}$ and D is the Jordan matrix. Thus,

$$z_{t+1} = QDQ^{-1}z_t.$$

Pre-multiplying both sides by Q^{-1} and letting $y_t \equiv Q^{-1}z_t$, it follows that

$$y_{t+1} = Dy_t.$$

Thus

$$y_t = D^t y_0 = D^t Q^{-1} z_0 = D^t Q^{-1} (x_0 - \bar{x}).$$

Furthermore, since $Q^{-1}z_t = y_t$, it follows that $z_t = Qy_t$, and therefore $z_t \equiv x_t - \bar{x} = Qy_t$. Hence,

$$x_t = Qy_t + \bar{x} = QD^tQ^{-1}(x_0 - \bar{x}) + \bar{x}.$$

□

As will become apparent, the structure of the matrix D^t follows a well-known pattern. The qualitative nature of the dynamical system can therefore be analyzed via direct examination of the equation

$$x_t = QD^tQ^{-1}(x_0 - \bar{x}) + \bar{x}. \quad (60)$$

2.1.6 Stability

In order to analyze the qualitative behavior of the dynamical system a distinction will be made among four possible cases each defined in terms of the corresponding nature of the eigenvalues: (1) distinct real eigenvalues, (2) repeated real eigenvalues, (3) distinct complex eigenvalues, and (4) repeated complex eigenvalues.

A. The matrix A has n distinct real eigenvalues.

Consider the system

$$x_{t+1} = Ax_t + B.$$

As was established in Lemma 3 and equation (60), if A has n distinct real eigenvalues $\{\lambda_1, \lambda_2, \dots, \lambda_n\}$, then there exists a nonsingular matrix Q , such that

$$x_t = Qy_t + \bar{x}.$$

Furthermore,

$$y_{t+1} = Dy_t,$$

where

$$D = \begin{bmatrix} \lambda_1 & & & 0 \\ & \lambda_2 & & \\ & & \dots & \\ 0 & & & \lambda_n \end{bmatrix}. \quad (61)$$

Following the method of iterations

$$y_t = D^t y_0 \quad (62)$$

where

$$D^t = \begin{bmatrix} \lambda_1^t & & & 0 \\ & \lambda_2^t & & \\ & & \cdots & \\ 0 & & & \lambda_n^t \end{bmatrix} \quad (63)$$

and therefore,

$$\begin{aligned} y_{1t} &= \lambda_1^t y_{10} \\ y_{2t} &= \lambda_2^t y_{20} \\ &\vdots \\ y_{nt} &= \lambda_n^t y_{n0} \end{aligned} \quad (64)$$

Since

$$x_t = Qy_t + \bar{x},$$

it follows that

$$\begin{bmatrix} x_{1t} \\ x_{2t} \\ \vdots \\ x_{nt} \end{bmatrix} = \begin{bmatrix} Q_{11} & Q_{12} & \cdots & Q_{1n} \\ Q_{21} & Q_{22} & \cdots & Q_{2n} \\ \vdots & \vdots & & \vdots \\ Q_{n1} & Q_{n2} & \cdots & Q_{nn} \end{bmatrix} \begin{bmatrix} \lambda_1^t y_{10} \\ \lambda_2^t y_{20} \\ \vdots \\ \lambda_n^t y_{n0} \end{bmatrix} + \begin{bmatrix} \bar{x}_1 \\ \bar{x}_2 \\ \vdots \\ \bar{x}_n \end{bmatrix}, \quad (65)$$

and therefore

$$x_{it} = \sum_{j=1}^n K_{ij} \lambda_j^t + \bar{x}_i, \quad \forall i = 1, 2, \dots, n, \quad (66)$$

where $K_{ij} \equiv Q_{ij} y_{j0}$.

Equation (66) provides the general solution for x_{it} in terms of the eigenvalues $\lambda_1, \lambda_2, \dots, \lambda_n$, the initial conditions $y_{10}, y_{20}, \dots, y_{n0}$, and the steady-state value \bar{x}_i . It sets the stage for the stability result stated in the following theorem.

Theorem 1 Consider the system $x_{t+1} = Ax_t + B$, where $x_t \in \mathfrak{R}^n$ and x_0 is given. Suppose that $|I - A| \neq 0$ and A has n distinct real eigenvalues $\{\lambda_1, \lambda_2, \dots, \lambda_n\}$. Then,

- the steady-state equilibrium $\bar{x} = [I - A]^{-1}B$ is globally stable if and only if

$$|\lambda_j| < 1, \quad \forall j = 1, 2, \dots, n;$$

- $\lim_{t \rightarrow \infty} x_t = \bar{x}$ if and only if $\forall j = 1, 2, \dots, n$

$$\{|\lambda_j| < 1 \text{ or } y_{j0} = 0\},$$

where $y_0 = Q^{-1}(x_0 - \bar{x})$, and Q is a nonsingular $n \times n$ matrix whose columns are the eigenvectors of the matrix A .

Proof: The steady-state equilibrium is globally stable if $\forall x_0 \in \mathfrak{R}^n \quad \lim_{t \rightarrow \infty} x_{it} = \bar{x}_i$ for all $i = 1, 2, \dots, n$. Thus it follows from equation (66) that global stability is satisfied if and only if $\forall k_{ij} \in \mathfrak{R} \quad \lim_{t \rightarrow \infty} \sum_j K_{ij} \lambda_j^t = 0$, namely if and only if $|\lambda_j| < 1 \quad \forall j = 1, 2, \dots, n$. As follows from equation (66) $\lim_{t \rightarrow \infty} x_{it} = \bar{x}_i$ if and only if either $|\lambda_j| < 1$, or $[|\lambda_j| \geq 1$ and $y_{j0} = 0]$, $\forall j = 1, 2, \dots, n$. Thus the second part follows as well. \square

Phase diagrams of 2-D uncoupled systems: Consider the system $y_{t+1} = Dy_t$, where D is a diagonal matrix with λ_1 and λ_2 along the diagonal. It follows that the steady-state equilibrium is

$$\bar{y} = (\bar{y}_1, \bar{y}_2) = (0, 0),$$

and

$$y_{1t} = \lambda_1^t y'_{10};$$

$$y_{2t} = \lambda_2^t y'_{20}.$$

The phase diagrams of this dynamical systems depend upon the sign of the eigenvalues, their relative magnitude, and their absolute value relative to unity.

(a) Positive Eigenvalues:

- Stable Node: $0 < \lambda_2 < \lambda_1 < 1$. (Figure 2.4 (a))

The steady-state equilibrium is globally stable. Namely, $\lim_{t \rightarrow \infty} y_{1t} = 0$ and $\lim_{t \rightarrow \infty} y_{2t} = 0$, $\forall (y_{10}, y_{20}) \in \mathfrak{R}^2$. The convergence to the steady-state equilibrium is monotonic. However, since $\lambda_2 < \lambda_1$ the convergence of y_{2t} is faster.

- Saddle: $0 < \lambda_2 < 1 < \lambda_1$. (Figure 2.4 (b))

The steady-state equilibrium is a saddle point. Namely, $\lim_{t \rightarrow \infty} y_{2t} = 0 \forall y_{20} \in \mathfrak{R}$, whereas $\lim_{t \rightarrow \infty} y_{1t} = 0$ if and only if $y_{10} = 0$. The convergence along the saddle path (i.e., the stable eigenspace or alternatively, the stable manifold) is monotonic.

- Focus: $0 < \lambda_1 = \lambda_2 < 1$. (Figure 2.4 (c))

The steady-state equilibrium is globally stable. Namely, $\lim_{t \rightarrow \infty} y_{1t} = 0$ and $\lim_{t \rightarrow \infty} y_{2t} = 0$, $\forall (y_{10}, y_{20}) \in \mathfrak{R}^2$. Convergence is monotonic and the speed of convergence is the same for each variable. Consequently every trajectory can be placed along a linear curve.

- Source: $1 < \lambda_1 < \lambda_2$. (Figure 2.4 (d))

The steady-state equilibrium is unstable. Namely, $\lim_{t \rightarrow \infty} y_{1t} = \pm\infty$ and $\lim_{t \rightarrow \infty} y_{2t} = \pm\infty$, $\forall (y_{10}, y_{20}) \in \mathfrak{R}^2 - \{0\}$. The divergence is monotonic. However, since $\lambda_2 > \lambda_1$ the divergence of y_{2t} is faster.

(b) Negative Eigenvalues:

- Stable Node (oscillating convergence): $-1 < \lambda_2 < \lambda_1 < 0$.

The steady-state equilibrium is globally stable. The convergence of both variables towards the steady-state equilibrium is oscillatory. Since $|\lambda_2| < |\lambda_1|$ the convergence of y_{2t} is faster.

- Saddle (oscillatory convergence/divergence) $\lambda_2 < -1 < \lambda_1 < 0$.

The steady-State equilibrium is a saddle. The convergence along the saddle path is oscillatory. Other than along the stable and the unstable manifolds, one variable converges in an oscillatory manner while the other variable diverges in an oscillatory manner.

- Focus (oscillatory convergence): $-1 < \lambda_1 = \lambda_2 < 0$.

The steady-state equilibrium is globally stable. Convergence is oscillatory.

- Source (oscillatory divergence): $\lambda_2 < \lambda_1 < -1$.

The steady-state equilibrium is unstable. Divergence is oscillatory.

(c) Mixed Eigenvalues (one positive and one negative eigenvalue): one variable converges (diverges) monotonically while the other is characterized by oscillatory convergence (divergence). Iterations are therefore reflected around one of the axes.

B. The matrix A has repeated real eigenvalues.

Consider the system

$$x_{t+1} = Ax_t + B.$$

As established previously, if A has n repeated real eigenvalues $\{\lambda, \lambda, \dots, \lambda\}$, then there exists a nonsingular matrix Q , such that

$$x_t = Qy_t + \bar{x}$$

and

$$y_{t+1} = Dy_t,$$

where

$$D = \begin{bmatrix} \lambda & & & & 0 \\ 1 & \lambda & & & \\ & 1 & \lambda & & \\ & & & \ddots & \\ 0 & & & 1 & \lambda \end{bmatrix} \quad (67)$$

Thus,

$$y_t = D^t y_0,$$

where for $t > n$

$$D^t = \begin{bmatrix} \lambda^t & 0 & 0 & 0 & 0 & 0 & 0 \\ t\lambda^{t-1} & \lambda^t & 0 & 0 & 0 & 0 & 0 \\ \frac{t(t-1)\lambda^{t-2}}{2!} & t\lambda^{t-1} & \lambda^t & 0 & 0 & 0 & 0 \\ \vdots & \frac{t(t-1)\lambda^{t-2}}{2!} & t\lambda^{t-1} & \lambda^t & 0 & 0 & 0 \\ \vdots & \ddots & \frac{t(t-1)\lambda^{t-2}}{2!} & t\lambda^{t-1} & \lambda^t & 0 & 0 \\ \vdots & \ddots & \ddots & \frac{t(t-1)\lambda^{t-2}}{2!} & t\lambda^{t-1} & \lambda^t & 0 \\ \ddots \frac{t(t-1)\cdots(t-n+2)\lambda^{t-n+1}}{(n-1)!} & \ddots & \ddots & \ddots & \frac{t(t-1)\lambda^{t-2}}{2!} & t\lambda^{t-1} & \lambda^t \end{bmatrix}.$$

Thus,

$$\begin{aligned} y_{1t} &= \lambda^t y_{10}; \\ y_{2t} &= t\lambda^{t-1} y_{10} + \lambda^t y_{20}; \\ y_{3t} &= \frac{t(t-1)\lambda^{t-2}}{2!} y_{10} + t\lambda^{t-1} y_{20} + \lambda^t y_{30}; \\ &\vdots \\ y_{nt} &= \frac{t(t-1)\cdots(t-n+2)\lambda^{t-n+1}}{(n-1)!} y_{10} + \cdots + \lambda^t y_{n0}. \end{aligned} \quad (68)$$

Therefore, $\forall i = 1, 2, \dots, n$,

$$y_{it} = \sum_{k=0}^{i-1} \binom{t}{k} \lambda^{t-k} y_{i-k,0}, \quad (69)$$

where

$$\binom{t}{k} = \frac{t!}{k!(t-k)!}. \quad (70)$$

Since

$$x_t = Qy_t + \bar{x},$$

it follows that $\forall i = 1, 2, \dots, n$,

$$x_{it} = \sum_{m=0}^{n-1} \binom{t}{m} \lambda^{t-m} K_{i,m+1} + \bar{x}_i, \quad (71)$$

where $K_{i,m+1}$ are constants that reflect all the product of the i^{th} row of the matrix Q and the column of initial conditions $(y_{10}, y_{20}, \dots, y_{n0})$.

Equation (71) is the general solution for x_{it} in terms of the repeated eigenvalue, λ , and the initial conditions. This solution sets the stage for the stability result stated in following theorem.

Theorem 2 Consider the system $x_{t+1} = Ax_t + B$, where $x_t \in \mathfrak{R}^n$ and x_0 is given. Suppose that $|I - A| \neq 0$ and A has n repeated real eigenvalues $\{\lambda, \lambda, \dots, \lambda\}$. Then, the steady-state equilibrium $\bar{x} = [I - A]^{-1}B$ is globally stable if and only if

$$|\lambda| < 1.$$

Proof: Follows immediately from (71). Note that $|\lambda| \geq 1$ cannot be consistent with any form of stability, since it would require that $y_{i0} = 0, \forall i = 1, 2, \dots, n$, namely, that the system starts at the steady-state equilibrium. \square

Phase Diagram of the 2-D Case:

Consider the system

$$y_{t+1} = Dy_t,$$

where

$$D = \begin{bmatrix} \lambda & 0 \\ 1 & \lambda \end{bmatrix}. \quad (72)$$

It follows that

$$y_t = D^t y_0,$$

where

$$D^t = \begin{bmatrix} \lambda^t & 0 \\ t\lambda^{t-1} & \lambda^t \end{bmatrix}. \quad (73)$$

Hence

$$y_{1t} = \lambda^t y_{10}; \quad (74)$$

$$y_{2t} = t\lambda^{t-1} y_{10} + \lambda^t y_{20}.$$

The derivation of the phase diagram of this uncoupled system is somewhat more involved. The system takes the form of

$$y_{1t+1} = \lambda y_{1t}; \quad (75)$$

$$y_{2t+1} = y_{1t} + \lambda y_{2t},$$

and therefore,

$$\Delta y_{1t} \equiv y_{1t+1} - y_{1t} = (\lambda - 1)y_{1t}; \quad (76)$$

$$\Delta y_{2t} \equiv y_{2t+1} - y_{2t} = y_{1t} + (\lambda - 1)y_{2t}.$$

Consequently,

$$\Delta y_{1t} = 0 \Leftrightarrow \{(y_{1t} = 0 \text{ or } \lambda = 1)\}; \quad (77)$$

$$\Delta y_{2t} = 0 \Leftrightarrow \{(y_{2t} = \frac{y_{1t}}{1-\lambda} \text{ and } \lambda \neq 1) \text{ or } (y_{1t} = 0 \text{ and } \lambda = 1)\}.$$

The phase diagram of the dynamical system depends upon the absolute magnitude of the eigenvalue relative to unity and on its sign.

- Improper (Stable) Node. $\lambda \in (0, 1)$ (Figure 2.5 (a))

$\Delta y_{1t} = 0$ if and only if $y_{1t} = 0$, namely, the y_{2t} - axis is the geometric place of all pair (y_{1t}, y_{2t}) such that $\Delta y_{1t} = 0$. Similarly, $\Delta y_{2t} = 0$ if and only if $y_{2t} = y_{1t}/(1 - \lambda)$, namely the $\Delta y_{2t} = 0$ locus is a linear curve with a slope greater than unity. Furthermore,

$$\Delta y_{1t} \begin{cases} > 0, & \text{if } y_{1t} < 0 \\ < 0, & \text{if } y_{1t} > 0 \end{cases} \quad (78)$$

and

$$\Delta y_{2t} = \begin{cases} < 0, & \text{if } y_{2t} > \frac{y_{1t}}{1-\lambda} \\ > 0, & \text{if } y_{2t} < \frac{y_{1t}}{1-\lambda}. \end{cases} \quad (79)$$

The variable y_{1t} converges monotonically to the steady-state equilibrium, $\bar{y} = 0$. y_{2t} however converges to the steady-state in a non-monotonic fashion. If $y_{20} < 0$ and $y_{1t} > 0$, then y_{2t} increases monotonically, crossing to the positive quadrant and peaking when it meets the $\Delta y_{2t} = 0$ locus. Afterwards it decreases monotonically and converges to the steady-state equilibrium $\bar{y} = 0$. The time path of each state variable is shown in Figure 2.5 (a).

Remark. The trajectories drawn in Figure 2.5 (a) require additional information. In particular, it should be noted that if the system is in quadrants I or IV it cannot cross into quadrants II or III, and vice versa. This is the case since if $y_{1t} > 0$ then $y_{1t+1} > 0$ and $\Delta y_{1t} < 0$ whereas if $y_{1t} < 0$ then $y_{1t+1} < 0$ and $\Delta y_{1t} > 0$. The system, thus, never crosses the y_2 - axis. Furthermore, it should be shown that if the system enters quadrant I or III it never leaves them. This is the case since if $y_{1t} > 0$ and $y_{2t} > 0$ then $y_{1t+1} > 0$ and $y_{2t+1} > 0$, whereas if $y_{1t} < 0$ and $y_{2t} < 0$ then $y_{1t+1} < 0$ and $y_{2t+1} < 0$.

- Improper Source. $\lambda \in (1, \infty)$. (Figure 2.5 (b))

The locus $\Delta y_{1t} = 0$ remains intact as in the case where $\lambda \in (0, 1)$, whereas the locus $\Delta y_{2t} = 0$ is a linear curve with a negative slope $1/(1 - \lambda)$. Furthermore,

$$\Delta y_{1t} = \begin{cases} > 0, & \text{if } y_{1t} > 0 \\ < 0, & \text{if } y_{1t} < 0 \end{cases} \quad (80)$$

and

$$\Delta y_{2t} = \begin{cases} > 0, & \text{if } y_{2t} > \frac{y_{1t}}{1-\lambda} \\ < 0, & \text{if } y_{2t} < \frac{y_{1t}}{1-\lambda}. \end{cases} \quad (81)$$

As depicted in Figure 2.5 (b) the system is unstable.

If $\lambda < 0$, the trajectory cannot be approximated by a continuous time trajectory. If $|\lambda| < 1$, the system oscillates between quadrants IV and II or I and III; and, convergence towards the steady-state equilibrium, $\bar{y} = 0$.

- $\lambda = 1$. Continuum of unstable steady-state equilibria (Figure 2.5 (c)).

The set of steady-state equilibria the entire y_{2t} axis. However, none is stable. This non-generic case represents the bifurcation point of the dynamical system. Namely, an infinitesimal change in the value of λ brings about a *qualitative* change in the nature of the dynamical system. In particular, the set of steady-state equilibria changes from a continuum and unstable equilibria to that a unique globally stable steady-state equilibrium.

C. The matrix A has distinct complex eigenvalues.

Consider the multi dimensional linear system

$$x_{t+1} = Ax_t + B.$$

As was established in Section 3.1.4, if A has $n/2$ pairs of distinct complex eigenvalues $\{\mu_1, \bar{\mu}_1, \mu_2, \bar{\mu}_2, \dots\}$ then there exists a nonsingular matrix Q , such that

$$x_t = Qy_t + \bar{x}$$

and

$$y_{t+1} = Dy_t,$$

where

$$D = \begin{bmatrix} \alpha_1 & -\beta_1 & 0 & 0 & \dots & \dots & 0 & 0 \\ \beta_1 & \alpha_1 & 0 & 0 & \dots & \dots & 0 & 0 \\ 0 & 0 & \alpha_2 & -\beta_2 & \dots & \dots & 0 & 0 \\ 0 & 0 & \beta_2 & \alpha_2 & \dots & \dots & 0 & 0 \\ & & & & \ddots & \ddots & 0 & 0 \\ & & & & \ddots & \ddots & 0 & 0 \\ 0 & 0 & 0 & 0 & \dots & \dots & \alpha_{n/2} & -\beta_{n/2} \\ 0 & 0 & 0 & 0 & \dots & \dots & \beta_{n/2} & \alpha_{n/2} \end{bmatrix}, \quad (82)$$

and $\mu_j \equiv \alpha_j + \beta_j i$, $\bar{\mu}_j \equiv \alpha_j - \beta_j i$ and $i \equiv \sqrt{-1}$.

Thus, for all $j = 1, 2, \dots, n/2$,¹⁰

$$\begin{bmatrix} y_{2j-1,t+1} \\ y_{2j,t+1} \end{bmatrix} = \begin{bmatrix} \alpha_j & -\beta_j \\ \beta_j & \alpha_j \end{bmatrix} \begin{bmatrix} y_{2j-1,t} \\ y_{2j,t} \end{bmatrix}. \quad (83)$$

Following the method of iterations, the trajectory of the system $\{y_t\}_{t=0}^{\infty}$ satisfies therefore the equation

$$\begin{bmatrix} y_{2j-1,t} \\ y_{2j,t} \end{bmatrix} = \begin{bmatrix} \alpha_j & -\beta_j \\ \beta_j & \alpha_j \end{bmatrix}^t \begin{bmatrix} y_{2j-1,0} \\ y_{2j,0} \end{bmatrix}. \quad (84)$$

This formulation, however, is not very informative about the qualitative behavior of the dynamical system. In particular, it is not apparent under which values of α_j and β_j the system will converge to its steady-state value. Namely, what are the necessary restriction under which $\lim_{t \rightarrow \infty} y_t = \bar{y}$. If the system is expressed instead in terms

¹⁰If n were odd, then there would be an additional real eigenvalue.

of the “polar coordinates” as will be defined below, the role of α_j and β_j in the determination of the stability results becomes apparent.

Consider the geometrical representation of the complex pair of eigen values $\mu_j \equiv \alpha_j + \beta_j i$, and $\bar{\mu}_j \equiv \alpha_j - \beta_j i$, in the complex plain, as as Figure 2.6. Let $r_j \equiv (\alpha_j^2 + \beta_j^2)^{1/2}$. r_j is the modulus of the j-th eigenvalue. It follows that $\alpha_j = r_j \cos \theta_j$ and $\beta_j = r_j \sin \theta_j$, and therefore

$$\begin{bmatrix} \alpha_j & -\beta_j \\ \beta_j & \alpha_j \end{bmatrix} = r_j \begin{bmatrix} \cos \theta_j & -\sin \theta_j \\ \sin \theta_j & \cos \theta_j \end{bmatrix}. \quad (85)$$

As established in the following lemma, if the right-hand side of (83) is raised to power t , the outcome permits a straightforward analysis of the dynamical system.

Lemma 6

$$\left\{ r_j \begin{bmatrix} \cos \theta_j & -\sin \theta_j \\ \sin \theta_j & \cos \theta_j \end{bmatrix} \right\}^t = r_j^t \begin{bmatrix} \cos t\theta_j & -\sin t\theta_j \\ \sin t\theta_j & \cos t\theta_j \end{bmatrix}.$$

Proof: The lemma follows from the trigonometric identities:

$$\cos (\theta_1 + \theta_2) = \cos \theta_1 \cos \theta_2 - \sin \theta_1 \sin \theta_2;$$

$$\sin (\theta_1 + \theta_2) = \cos \theta_1 \sin \theta_2 + \sin \theta_1 \cos \theta_2.$$

□

Theorem 3 Consider the system $x_{t+1} = Ax_t + B$, where $x_t \in \mathbb{R}^n$. Suppose that $|I - A| \neq 0$ and suppose that A has $n/2$ pairs $\{\mu_1, \bar{\mu}_1, \mu_2, \bar{\mu}_2, \dots, \mu_{n/2}, \bar{\mu}_{n/2}\}$ of distinct complex eigenvalues where $\mu_j \equiv \alpha_j + \beta_j i$, $\bar{\mu}_j = \alpha_j - \beta_j i$, and $i \equiv \sqrt{-1}$; $j = 1, 2, \dots, n/2$. Then, the steady-state equilibrium system is globally (asymptotically) stable if and only if

$$r_j \equiv (\alpha_j^2 + \beta_j^2)^{1/2} < 1, \quad \forall j = 1, 2, \dots, n/2.$$

Proof: Since

$$\begin{bmatrix} y_{2j-1,t} \\ y_{2j,t} \end{bmatrix} = r_j^t \begin{bmatrix} \cos t\theta_j & -\sin t\theta_j \\ \sin t\theta_j & \cos t\theta_j \end{bmatrix} \begin{bmatrix} y_{2j-1,0} \\ y_{2j,0} \end{bmatrix} \quad (86)$$

it follows from the fact that $x_t = Qy_t + \bar{x}$ that

$$x_{it} = \sum_j r_j^t [K_{ij} \cos t\theta_j + \tilde{K}_{ij} \sin t\theta_j] + \bar{x}_i. \quad (87)$$

where K_{ij} and \tilde{K}_{ij} are the constants associated with the relevant elements of the matrix Q and the initial conditions $y_{2j-1,0}$ and $y_{2j,0}$. Since $0 \leq |\cos t\theta_j| \leq 1$ and $0 \leq |\sin t\theta_j| \leq 1$, it follows that $\lim_{t \rightarrow \infty} x_{it} = \bar{x}_i$ if and only if $r_j < 1 \quad \forall j = 1, 2, \dots, n/2$.
□

Phase Diagram of a 2-D system:

Consider the system

$$\begin{bmatrix} y_{1t+1} \\ y_{2t+1} \end{bmatrix} = \begin{bmatrix} \alpha & -\beta \\ \beta & \alpha \end{bmatrix} \begin{bmatrix} y_{1t} \\ y_{2t} \end{bmatrix}, \quad (88)$$

Namely,

$$\begin{aligned} y_{1t+1} &= \alpha y_{1t} - \beta y_{2t}; \\ y_{2t+1} &= \beta y_{1t} + \alpha y_{2t}. \end{aligned} \quad (89)$$

Depending on the values of the parameters r and β the system may exhibit a variety of behavior.

(a) Periodic orbit: $r = 1$

- $\beta > 0$: counter-clockwise periodic orbit (Figures 2.7 (a)).

The system exhibits a counterclockwise periodic orbit. Consider Figure 2.7 (a). Suppose that $r = 1$, $\beta = 1$ and consequently $\alpha = 0$. Suppose further that the

initial condition $(y_{10}, y_{20}) = (1, 0)$. It follows from (89) that $(y_{11}, y_{21}) = (0, 1)$, $(y_{12}, y_{22}) = (-1, 0)$, $(y_{13}, y_{23}) = (0, -1)$ and $(y_{14}, y_{24}) = (1, 0)$. Thus the system is characterized in this example by a four-period cycle with a counter-clockwise orientation.

- $\beta < 0$: clockwise periodic orbit (Figure 2.7 (b)).

The system exhibits a clockwise period orbit. Consider Figure 2.7 (b). Suppose that $r = 1$, $\beta = -1$ and consequently $\alpha = 0$. Again, starting from $(1, 0)$, the system exhibits a clockwise four-period cycle; $\{(1, 0), (0, -1), (-1, 0), (0, 1)\}$. Note that α governs the pace of the motion.

(b) Spiral sink: $r < 1$ (Figure 2.7 (c)).

The system is characterized by a spiral convergence to the steady-state equilibrium. If $\beta > 0$ the motion is counter-clockwise, whereas if $\beta < 0$ the motion is clockwise.

(c) Spiral Source: $r > 1$. (Figure 2.7(d)).

The system exhibits a spiral divergence from the steady-state equilibrium with either counter-clockwise motion ($\beta > 0$) or clockwise motion ($\beta < 0$).

D. The matrix A has $n/2$ pairs of repeated complex eigenvalues.

Consider the system $x_{t+1} = Ax_t + B$. As was established in Section 3.1.4, if A has $n/2$ pairs of repeated complex eigenvalues $\{\mu, \bar{\mu}, \mu, \bar{\mu}, \dots, \mu, \bar{\mu}\}$ then there exists a non-singular matrix Q , such that $x_t = Qy_t + \bar{x}$ and $y_{t+1} = Dy_t$, where

$$D = \begin{bmatrix} \alpha & -\beta & 0 & 0 & 0 & 0 & 0 & 0 & 0 & 0 \\ \beta & \alpha & 0 & 0 & 0 & 0 & 0 & 0 & 0 & 0 \\ 1 & 0 & \alpha & -\beta & 0 & 0 & 0 & 0 & 0 & 0 \\ 0 & 1 & \beta & \alpha & 0 & 0 & 0 & 0 & 0 & 0 \\ 0 & 0 & 1 & 0 & \alpha & -\beta & 0 & 0 & 0 & 0 \\ 0 & 0 & 0 & 1 & \beta & \alpha & 0 & 0 & 0 & 0 \\ 0 & 0 & 0 & 0 & 1 & 0 & \alpha & -\beta & 0 & 0 \\ 0 & 0 & 0 & 0 & 0 & 1 & \beta & \alpha & 0 & 0 \\ 0 & 0 & 0 & 0 & 0 & 0 & 1 & 0 & \alpha & -\beta \\ 0 & 0 & 0 & 0 & 0 & 0 & 0 & 1 & \beta & \alpha \end{bmatrix}.$$

and $\mu = \alpha + \beta i$, $\bar{\mu} = \alpha - \beta i$, and $i \equiv \sqrt{-1}$. Hence, $y_t = D^t y_0$, where in light of equation (85)

$$D^t = \begin{bmatrix} r^t \cos t\theta & -r^t \sin t\theta & 0 & 0 & 0 & 0 \\ r^t \sin t\theta & r^t \cos t\theta & 0 & 0 & 0 & 0 \\ tr^{t-1} \cos(t-1)\theta & -tr^{t-1} \sin(t-1)\theta & r^t \cos t\theta & -r^t \sin t\theta & \ddots & \ddots & 0 & 0 \\ tr^{t-1} \sin(t-1)\theta & tr^{t-1} \cos(t-1)\theta & r^t \sin t\theta & r^t \cos t\theta & \ddots & \ddots & 0 & 0 \\ \frac{t(t-1)r^{t-2} \cos(t-2)\theta}{2!} & -\frac{t(t-1)r^{t-2} \sin(t-2)\theta}{2!} & tr^{t-1} \cos(t-1)\theta & -tr^{t-1} \sin(t-1)\theta & \ddots & \ddots & 0 & 0 \\ \frac{t(t-1)r^{t-2} \sin(t-2)\theta}{2!} & \frac{t(t-1)r^{t-2} \cos(t-2)\theta}{2!} & tr^{t-1} \sin(t-1)\theta & tr^{t-1} \cos(t-1)\theta & \ddots & \ddots & 0 & 0 \\ \vdots & \vdots & \ddots & & & & r^t \cos t\theta & -r^t \sin t\theta \\ & & \ddots & & & & r^t \sin t\theta & r^t \cos t\theta \end{bmatrix}$$

Thus $\forall j = 1, 2, \dots, n/2$,

$$\begin{aligned} y_{2j-1,t} &= \sum_{k=0}^{t-1} r^{t-k} \binom{t}{k} [\cos(t-k)\theta y_{2j-1,0} - \sin(t-k)\theta y_{2j,0}]; \\ y_{2j,t} &= \sum_{k=0}^{t-1} r^{t-k} \binom{t}{k} [\sin(t-k)\theta y_{2j-1,0} + \cos(t-k)\theta y_{2j,0}]. \end{aligned} \tag{90}$$

Since $x_t = Qy_t + \bar{x}$ the theorem follows:

Theorem 4 Consider the system $x_{t+1} = Ax_t + B$, where $x_t \in \mathbb{R}^n$. Suppose that $|I - A| \neq 0$ and suppose that A has $n/2$ pairs of repeated eigenvalues $\{\mu, \bar{\mu}, \mu, \bar{\mu}, \dots\}$, where $n \equiv \alpha + \beta i$, $\bar{n} \equiv \alpha - \beta i$, and $i \equiv \sqrt{-1}$. Then the steady-state equilibrium is globally stable if and only if

$$r \equiv [\alpha^2 + \beta^2]^{1/2} < 1.$$

2.2 Nonlinear Systems

Consider the system of autonomous nonlinear first-order difference equations:

$$x_{t+1} = \phi(x_t); \quad t = 0, 1, 2, \dots, \infty, \quad (91)$$

where

$$\phi: \mathfrak{R}^n \rightarrow \mathfrak{R}^n,$$

and the initial value of the n -dimensional state variable, x_0 , is given. Namely,

$$\begin{aligned} x_{1t+1} &= \phi^1(x_{1t}, x_{2t}, \dots, x_{nt}) \\ x_{2t+1} &= \phi^2(x_{1t}, x_{2t}, \dots, x_{nt}) \\ &\vdots \\ x_{nt+1} &= \phi^n(x_{1t}, x_{2t}, \dots, x_{nt}). \end{aligned} \quad (92)$$

2.2.1 Local Analysis

Suppose that the dynamical system has a steady-state equilibrium, \bar{x} . Namely $\exists \bar{x} \in \mathfrak{R}^n$ such that $\bar{x} = \phi(\bar{x})$. A Taylor expansion of $x_{it+1} = \phi(x_t)$, around the steady-state value, \bar{x} , yields

$$x_{it+1} = \phi^i(x_t) = \phi^i(\bar{x}) + \sum_{j=1}^n \phi_j^i(\bar{x})(x_{jt} - \bar{x}_j) + \dots + R_n, \quad (93)$$

where $\phi_j^i(\bar{x})$ is the partial derivative of the function $\phi^i(x_t)$ with respect to x_{jt} , evaluated at \bar{x} (i.e., $\phi_j^i(\bar{x}) = \partial \phi^i(x_t) / \partial x_{jt}$). Thus, the linearized equation around the steady-state \bar{x} is given by

$$x_{it+1} = \phi_1^i(\bar{x})x_{1t} + \phi_2^i(\bar{x})x_{2t} + \dots + \phi_n^i(\bar{x})x_{nt} + \phi^i(\bar{x}) - \sum_{j=1}^n \phi_j^i(\bar{x})\bar{x}_j. \quad (94)$$

The linearized system, is therefore:

$$\begin{bmatrix} x_{1t+1} \\ x_{2t+1} \\ \vdots \\ x_{nt+1} \end{bmatrix} = \begin{bmatrix} \phi_1^1(\bar{x}) & \phi_2^1(\bar{x}) & \cdots & \phi_n^1(\bar{x}) \\ \phi_1^2(\bar{x}) & \phi_2^2(\bar{x}) & \cdots & \phi_n^2(\bar{x}) \\ \vdots & \vdots & & \vdots \\ \phi_1^n(\bar{x}) & \phi_2^n(\bar{x}) & \cdots & \phi_n^n(\bar{x}) \end{bmatrix} \begin{bmatrix} x_{1t} \\ x_{2t} \\ \vdots \\ x_{nt} \end{bmatrix} + \begin{bmatrix} \phi^1(\bar{x}) - \sum_{j=1}^n \phi_j^1(\bar{x})\bar{x}_j \\ \phi^2(\bar{x}) - \sum_{j=1}^n \phi_j^2(\bar{x})\bar{x}_j \\ \vdots \\ \phi^n(\bar{x}) - \sum_{j=1}^n \phi_j^n(\bar{x})\bar{x}_j \end{bmatrix}.$$

Thus, the nonlinear system has been approximated, locally (around a steady-state equilibrium) by a linear system,

$$x_{t+1} = Ax_t + B,$$

where

$$A \equiv \begin{bmatrix} \phi_1^1(\bar{x}) & \cdots & \phi_n^1(\bar{x}) \\ \vdots & & \vdots \\ \phi_1^n(\bar{x}) & \cdots & \phi_n^n(\bar{x}) \end{bmatrix} \equiv \mathcal{D}\phi(\bar{x}); \quad (95)$$

is the Jacobian matrix of $\phi(x_t)$ evaluated at \bar{x} , and

$$B \equiv \begin{bmatrix} \phi^1(\bar{x}) - \sum_{j=1}^n \phi_j^1(\bar{x})\bar{x}_j \\ \vdots \\ \phi^n(\bar{x}) - \sum_{j=1}^n \phi_j^n(\bar{x})\bar{x}_j \end{bmatrix}. \quad (96)$$

As is established in the theorem below the local behavior of the nonlinear dynamical system can be assessed on the basis of the behavior of the linear system that approximate the nonlinear one in the vicinity of the steady-state equilibrium. Hence, the eigenvalues of the Jacobian matrix A determine the local behavior of the nonlinear system according to the results stated in Theorems 1-4.

Definition 6 Consider the nonlinear dynamical system

$$x_{t+1} = \phi(x_t).$$

- The local stable manifold, $W_{loc}^s(\bar{x})$, of a steady-state equilibrium, \bar{x} , is

$$W_{loc}^s(\bar{x}) = \{x \in U \mid \lim_{n \rightarrow +\infty} \phi^n(x) = \bar{x} \text{ and } \phi^n(x) \in U \quad \forall n \in N\};$$

- The local unstable manifold, $W_{loc}^u(\bar{x})$, of a steady-state equilibrium, \bar{x} , is

$$W_{loc}^u(\bar{x}) = \{x \in U \mid \lim_{n \rightarrow +\infty} \phi^{-n}(x) = \bar{x} \text{ and } \phi^n(\bar{x}) \in U \quad \forall n \in \mathbb{N}\},$$

where $U \equiv B_\epsilon(\bar{x})$ for some $\epsilon > 0$, and $\phi^n(x)$ is the n^{th} iterate of x under ϕ .

Thus, the local stable [unstable] manifold is the geometric place of all vectors $x \in \mathbb{R}^n$ in an ϵ -neighborhood of the steady-state equilibrium whose elements approach asymptotically the steady-state equilibrium, \bar{x} , as the number of iterations under the map ϕ [ϕ^{-1}] approaches infinity.

Definition 7 Consider the map $\phi : \mathbb{R}^n \rightarrow \mathbb{R}^n$ and let $\mathcal{D}\phi(\bar{x})$ be the Jacobian matrix of $\phi(x)$ evaluated at a steady-state equilibrium \bar{x} .

- The stable eigenspace, $E^s(\bar{x})$, of the steady-state equilibrium, \bar{x} is

$$E^s(\bar{x}) = \text{span}\{\text{eigenvectors of } \mathcal{D}\phi(\bar{x}) \text{ whose eigenvalues have modulus less than } 1\}.$$

- The unstable eigenspace, $E^u(\bar{x})$, of the steady-state equilibrium, \bar{x} , is

$$E^u(\bar{x}) = \text{span}\{\text{eigenvectors of } \mathcal{D}\phi(\bar{x}) \text{ whose eigenvalues have modulus greater than } 1\}.$$

Definition 8 Consider the map $\phi : \mathbb{R}^n \rightarrow \mathbb{R}^n$ and let $D\phi(\bar{x})$ be the Jacobian matrix of $\phi(x)$, evaluated at a steady-state equilibrium \bar{x} . The steady-state equilibrium, \bar{x} is an hyperbolic fixed point if $D\phi(\bar{x})$ has no eigenvalues of modulus one.

Theorem 5 (The Stable Manifold Theorem). Let $\phi : \mathbb{R}^n \rightarrow \mathbb{R}^n$ be a C^1 diffeomorphism¹¹ with a hyperbolic fixed point \bar{x} . Then there exist locally stable and unstable manifolds $W_{loc}^s(\bar{x})$ and $W_{loc}^u(\bar{x})$, that are tangent, at \bar{x} to the Eigenspaces $E^s(\bar{x})$ and $E^u(\bar{x})$ of the Jacobian matrix $D\phi(\bar{x})$, and are of corresponding dimension.

Proof. See Nitecki (1971).

¹¹A diffeomorphism is a smooth function with a smooth inverse.

2.2.2 Global Analysis.

A global analysis of a multi-dimension nonlinear system is rather difficult. In the context of a two-dimensional dynamical system, however, a phase diagram in addition to the local results that can be generated on the basis of the analysis of the linearized system, may set the stage for a global characterization of the dynamical system. In particular, the global properties of the dynamical system can be generated from the properties of the local stable and unstable manifolds:

Definition 9 Consider the nonlinear dynamical system

$$x_{t+1} = \phi(x_t).$$

- The global stable manifold $W^s(\bar{x})$ of a steady-state equilibrium, \bar{x} , is

$$W^s(\bar{x}) = \cup_{n \in \mathbb{N}} \{\phi^{-n}(W_{loc}^s(\bar{x}))\}.$$

- The global unstable manifold $W^u(\bar{x})$ of a steady-state equilibrium, \bar{x} , is

$$W^u(\bar{x}) = \cup_{n \in \mathbb{N}} \{\phi^n(W_{loc}^u(\bar{x}))\}.$$

Thus the *global stable manifold* is obtained by the union of all backward iterates under the map ϕ , of the local stable manifold (see Figure 3.1).

Theorem 6 provides a very restrictive sufficient condition for global stability that is unlikely to be satisfied by a conventional economic system. In light of the *Contraction Mapping Theorem*, the sufficient conditions for global stability in the one-dimensional case (Corollary 3) can be generalized for a multi-dimensional dynamical system.

Theorem 6 A stationary equilibrium of the multi-dimensional, autonomous, first-order difference equation, $x_{t+1} = \phi(x_t)$ exists, is unique, and is globally stable if $\phi : \mathbb{R}^n \rightarrow \mathbb{R}^n$ is a contraction mapping.

3 Higher-Order Difference Equations

3.1 Linear Systems

3.1.1 Second-Order Systems

Consider the one-dimensional, autonomous, *second-order* difference equation

$$x_{t+2} + a_1x_{t+1} + a_0x_t + b = 0, \tag{97}$$

where $x_t \in \mathfrak{R}$, $a_0, a_1, b \in \mathfrak{R}$, and the initial conditions (x_0, x_1) are given. In order to solve this system in a familiar manner, this system can be converted into a two-dimensional first-order system.

Let $x_{t+1} \equiv y_t$. Then, the one-dimensional, second-order difference equation is transformed into a system of two-dimensional first-order linear difference equations. Since $x_{t+1} \equiv y_t$ implies $x_{t+2} = y_{t+1}$, it follows that

$$\begin{cases} y_{t+1} + a_1y_t + a_0x_t + b = 0; \\ x_{t+1} = y_t, \end{cases} \tag{98}$$

or,

$$\begin{cases} y_{t+1} = -a_1y_t - a_0x_t - b; \\ x_{t+1} = y_t. \end{cases} \tag{99}$$

Thus,

$$\begin{bmatrix} y_{t+1} \\ x_{t+1} \end{bmatrix} = \begin{bmatrix} -a_1 & -a_0 \\ 1 & 0 \end{bmatrix} \begin{bmatrix} y_t \\ x_t \end{bmatrix} + \begin{bmatrix} -b \\ 0 \end{bmatrix}, \tag{100}$$

where the initial conditions of the two state variables $y_0 = x_1$ and x_0 are given.

Thus, the second-order system has been transformed into a system of two first-order linear difference equations that can be analyzed according to Theorems 1-4.

3.1.2 Third-Order Systems

Consider the system

$$x_{t+3} + a_2x_{t+2} + a_1x_{t+1} + a_0x_t + b = 0, \quad (101)$$

where $x_t \in \mathfrak{R}$, $a_0, a_1, a_2, b \in \mathfrak{R}$, and the initial conditions (x_0, x_1, x_2) are given.

Let $x_{t+1} \equiv y_t$, and, $x_{t+2} = y_{t+1} \equiv z_t$. Then, the third-order system is transformed into a system of three first-order equations which can be analyzed on the basis of Theorems 1–4. Since $x_{t+2} = y_{t+1} = z_t$ implies that $x_{t+3} = y_{t+2} = z_{t+1}$, it follows that

$$\begin{cases} z_{t+1} + a_2z_t + a_1y_t + a_0x_t + b = 0; \\ x_{t+2} = y_{t+1} \\ x_{t+1} = y_t \end{cases} \quad (102)$$

or

$$\begin{cases} z_{t+1} = -a_2z_t - a_1y_t - a_0x_t - b; \\ y_{t+1} = z_t; \\ x_{t+1} = y_t. \end{cases} \quad (103)$$

Thus,

$$\begin{bmatrix} z_{t+1} \\ y_{t+1} \\ x_{t+1} \end{bmatrix} = \begin{bmatrix} -a_2 & -a_1 & -a_0 \\ 1 & 0 & 0 \\ 0 & 1 & 0 \end{bmatrix} \begin{bmatrix} z_t \\ y_t \\ x_t \end{bmatrix} + \begin{bmatrix} -b \\ 0 \\ 0 \end{bmatrix}. \quad (104)$$

3.1.3 Nth-Order System

Consider an Nth order system

$$x_{t+n} + a_{n-1}x_{t+n-1} + \cdots + a_1x_{t+1} + a_0x_t + b = 0. \quad (105)$$

Let

$$\begin{aligned}
x_{t+1} &\equiv y_{1t} \\
x_{t+2} &= y_{1,t+1} \equiv y_{2t} \\
x_{t+3} &= y_{1,t+2} = y_{2,t+1} \equiv y_{3t} \\
&\vdots \\
x_{t+n-1} &= y_{1,t+n-2} = y_{2,t+n-3} = \cdots = y_{n-2,t+1} \equiv y_{n-1,t}
\end{aligned} \tag{106}$$

It follows that $x_{t+n} = y_{n-1,t+1}$

$$\begin{bmatrix} y_{n-1,t+1} \\ y_{n-2,t+1} \\ y_{n-3,t+1} \\ \vdots \\ \vdots \\ y_{3,t+1} \\ y_{2,t+1} \\ y_{1,t+1} \\ x_{t+1} \end{bmatrix} = \begin{bmatrix} -a_{n-1} & -a_{n-2} & \dots & \dots & \dots & \dots & -a_2 & -a_1 & -a_0 \\ 1 & 0 & 0 & 0 & 0 & 0 & 0 & 0 & 0 \\ 0 & 1 & 0 & 0 & 0 & 0 & 0 & 0 & 0 \\ \vdots & \ddots & \ddots & \ddots & \ddots & \ddots & \ddots & \ddots & \\ \vdots & \ddots & & \ddots & \ddots & \ddots & \ddots & \ddots & \\ 0 & 0 & 0 & 0 & 1 & 0 & 0 & 0 & 0 \\ 0 & 0 & 0 & 0 & 0 & 1 & 0 & 0 & 0 \\ 0 & 0 & 0 & 0 & 0 & 0 & 1 & 0 & 0 \\ 0 & 0 & 0 & 0 & 0 & 0 & 0 & 1 & 0 \end{bmatrix} \begin{bmatrix} y_{n-1,t} \\ y_{n-2,t} \\ y_{n-3,t} \\ \vdots \\ \vdots \\ y_{3,t} \\ y_{2,t} \\ y_{1,t} \\ x_t \end{bmatrix} + \begin{bmatrix} -b \\ 0 \\ \vdots \\ \vdots \\ \vdots \\ 0 \\ 0 \\ 0 \\ 0 \end{bmatrix}$$

This is a system of n first-order linear difference equations that can be solved and analyzed qualitatively according to the methods developed in Sections 1 and 2.

3.2 Nonlinear System

Consider the nonlinear n^{th} -order system

$$x_{t+n} = \phi(x_{t+n-1}, x_{t+n-2}, x_{t+n-3}, \dots, x_t).$$

Let

$$\begin{aligned}
x_{t+1} &\equiv y_{1t} \\
x_{t+2} &= y_{1,t+1} \equiv y_{2t} \\
x_{t+3} &= y_{1,t+2} = y_{2,t+1} \equiv y_{3t} \\
&\vdots \\
x_{t+n-1} &= y_{1,t+n-2} = y_{2,t+n-3} = \cdots = y_{n-2,t+1} \equiv y_{n-1,t}
\end{aligned} \tag{107}$$

It follows that

$$\begin{aligned}
y_{n-1,t+1} &= \phi(y_{n-1,t}, y_{n-2,t}, y_{n-3,t}, \dots, x_t) \\
y_{n-2,t+1} &= y_{n-1,t} \\
&\vdots \\
y_{1,t+1} &= y_{1,t}.
\end{aligned} \tag{108}$$

Thus, the n^{th} -order nonlinear system can be represented as a system of n first-order nonlinear difference equations that can be analyzed according to the methods developed in Sections 1 and 2.

4 Non-Autonomous Systems

Consider the non-autonomous linear system

$$x_{t+1} = A(t)x_t + B(t), \tag{109}$$

and the non-autonomous nonlinear system

$$x_{t+1} = f(x_t, t). \tag{110}$$

The non-autonomous system can be converted into an autonomous one.

Let $y_t \equiv t$. Then $y_{t+1} = t + 1 = y_t + 1$. Thus the linear system is

$$\begin{aligned}
x_{t+1} &= A(y_t)x_t + B(y_t); \\
y_{t+1} &= y_t + 1.
\end{aligned} \tag{111}$$

whereas the nonlinear system becomes

$$\begin{aligned}
x_{t+1} &= f(x_t, y_t); \\
y_{t+1} &= y_t + 1.
\end{aligned} \tag{112}$$

Namely, the non-autonomous system is converted into a higher dimensional autonomous system. The qualitative analysis provided by Theorems 1–5 that are based on the behavior of the system in the vicinity of a steady-state equilibrium, is not applicable, however since there exists no $\bar{y} \in \mathfrak{R}$ such that $\bar{y} = \bar{y} + 1$ (i.e., time does not come to

a halt), and thus neither the linear system nor the nonlinear system has a steady-state equilibrium.¹²

The method of analysis for this system will depend on the particular form of the dynamical system and the possibility of redefining the state variables (possibly in terms of growth rates) so as to assure the existence of steady-state equilibria.

¹²The relevant state variable, x_t , may have a steady-state regardless of the value of y_t , nevertheless, the method of analysis provided earlier is not applicable for this case.

References

- [1] Arnold, V.I., 1973, *Ordinary Differential Equations*, MIT Press: Cambridge, MA.
- [2] Galor, O. (1992), "A Two Sector Overlapping-Generations Model: A Global Characterization of the Dynamical System," *Econometrica*, 60, 1351-1386.
- [3] Hale, J., 1980, *Ordinary Differential Equations*, Wiley: New York.
- [4] Hale, J. and H. Kocak, 1991, *Dynamics and Bifurcations*, Springer-Verlag: New York.
- [5] Hirsch, M.W. and S. Smale, 1974, *Differential Equations, Dynamical Systems, and*
- [6] Kocak, H., 1988, *Differential and Difference Equations through Computer Experiments*, Springer-Verlag: New York.
- [7] Nitecki, Z., 1971, *Differentiable Dynamics*, MIT Press: Cambridge, MA.

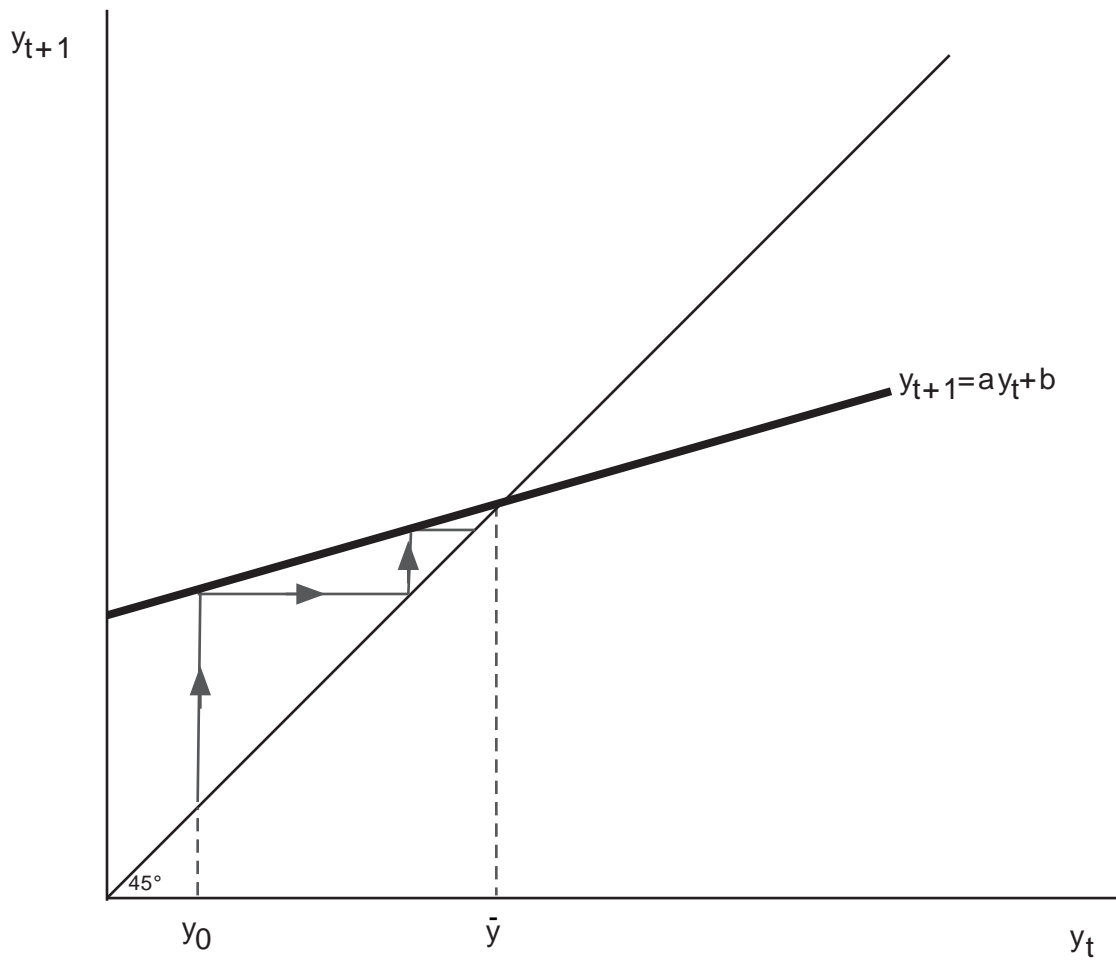

Figure 1.1

$$a \in (0,1)$$

Unique, Globally Stable, Steady-State Equilibrium
(Monotonic Convergence)

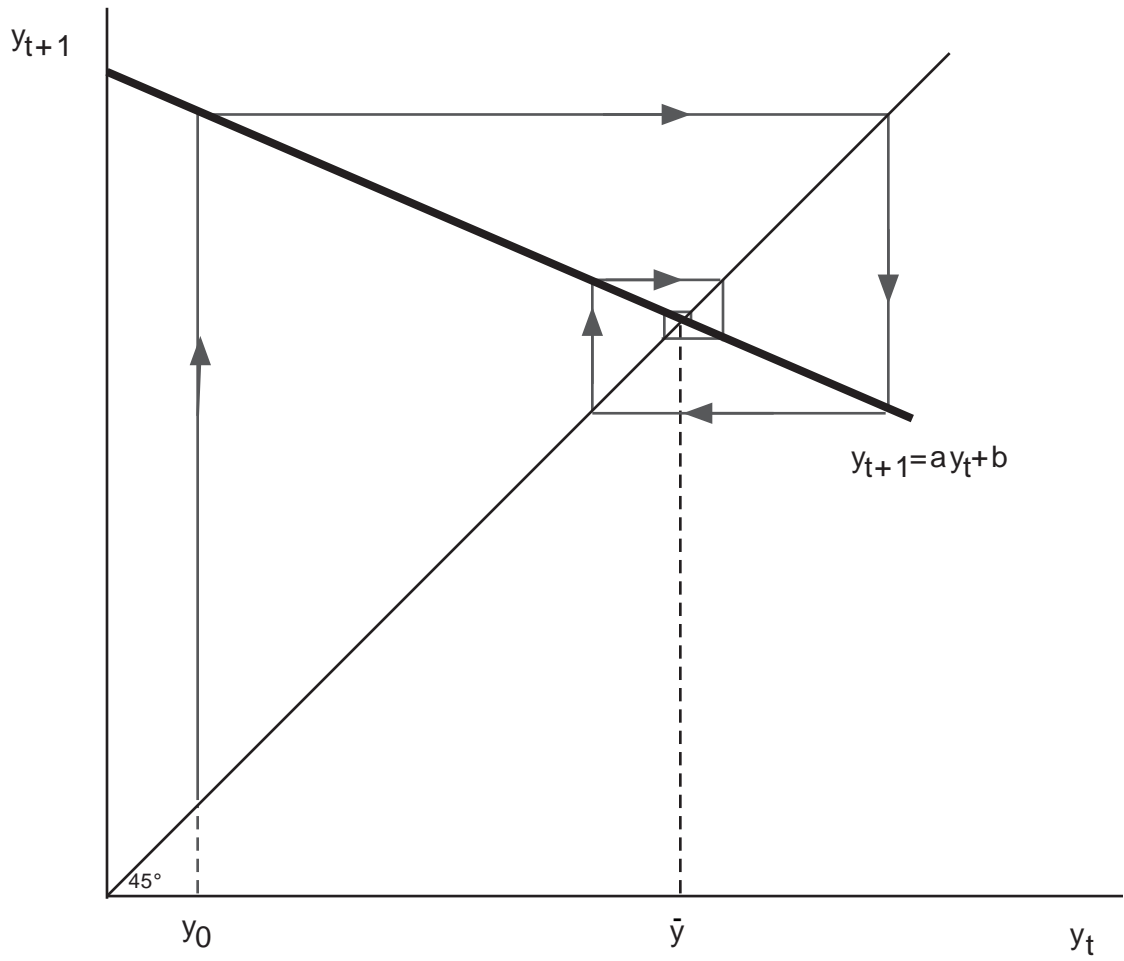

Figure 1.2

$a \in (-1, 0)$

Unique, Globally Stable, Steady-State Equilibrium
(Oscillatory Convergence)

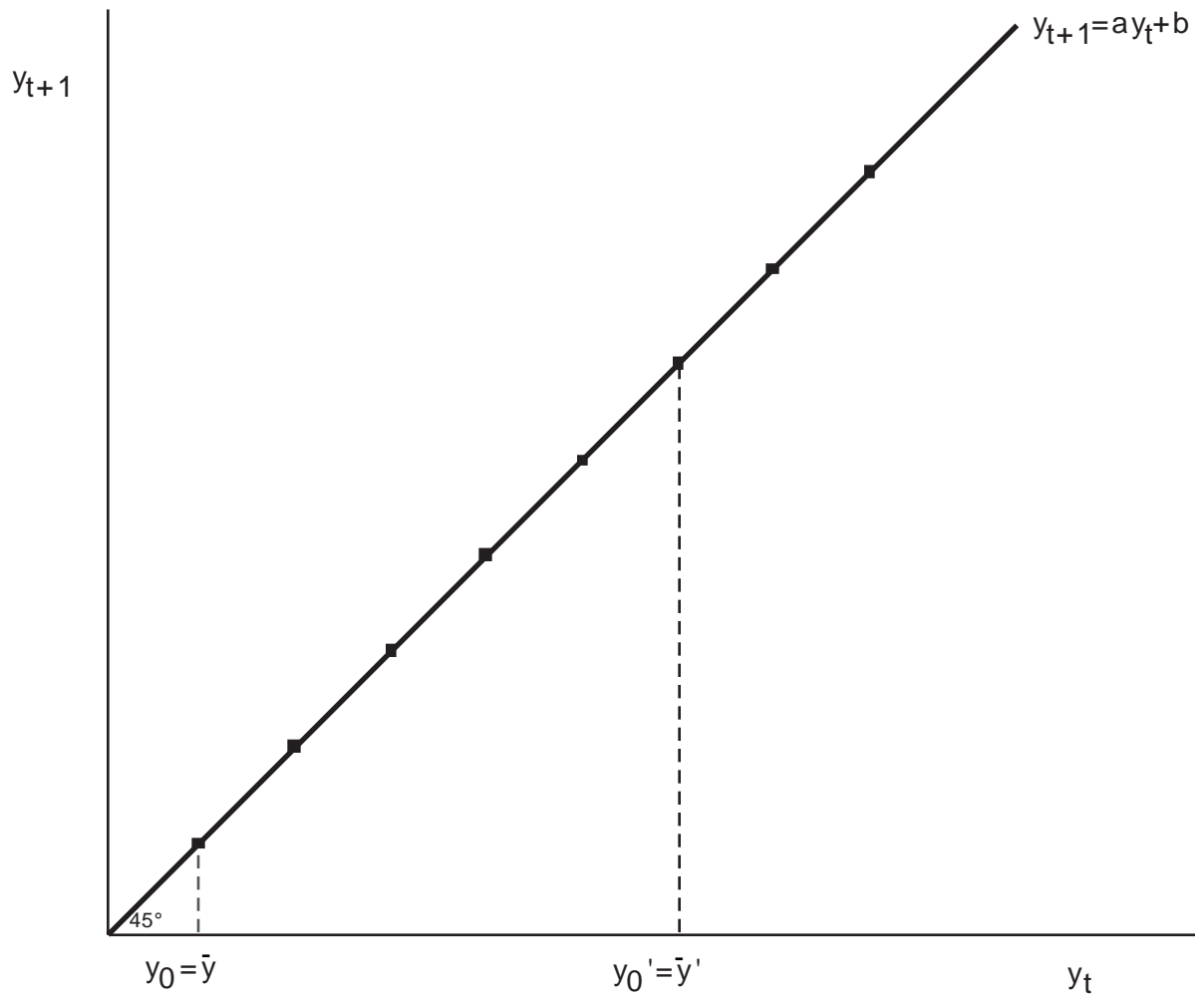

Figure 1.3

$a = 1$ & $b = 0$

Continuum of Unstable Steady-State Equilibria

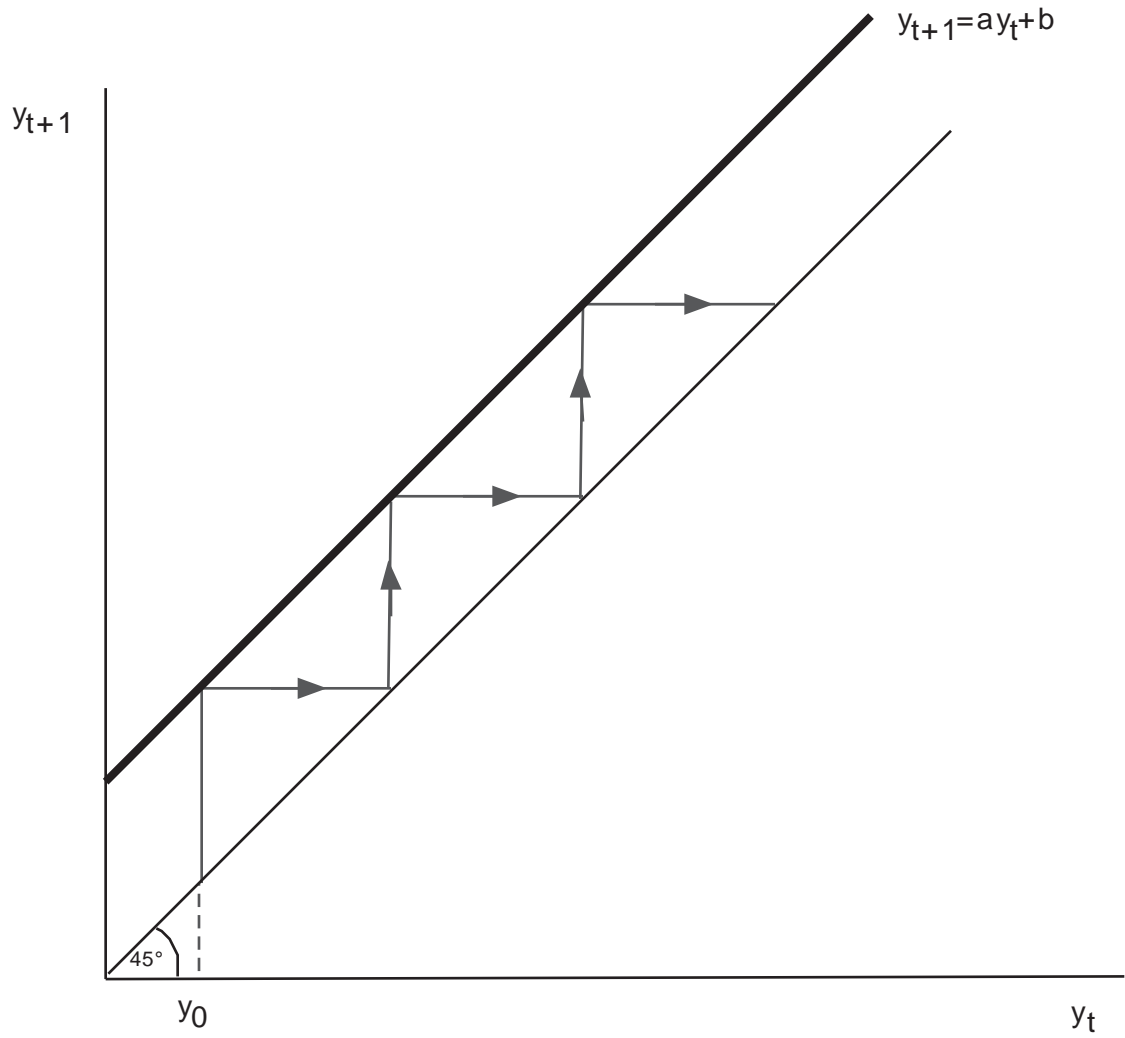

Figure 1.4

$$a = 1 \text{ \& } b \neq 0$$

Continuum of Unstable Steady-State Equilibria

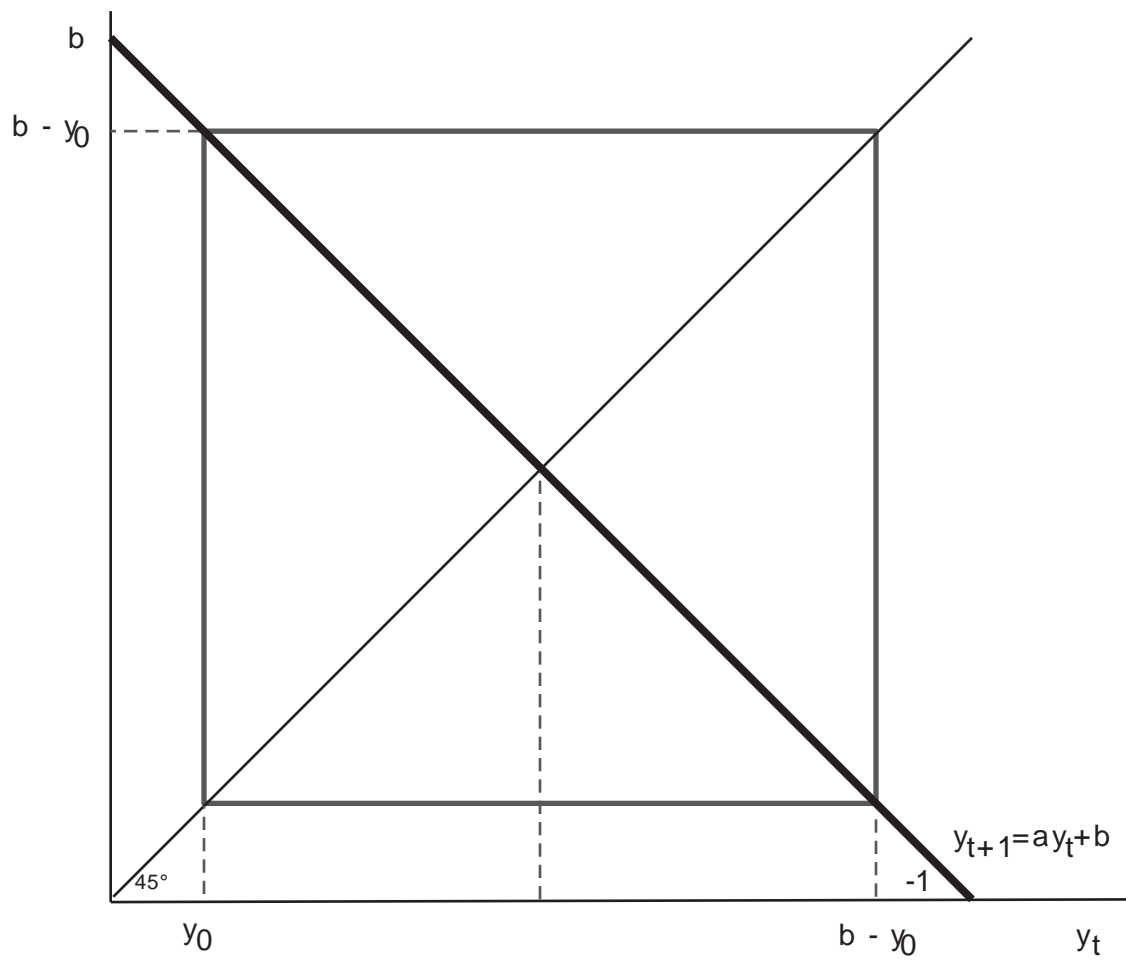

Figure 1.5
 $a = -1$
 Two Period Cycle

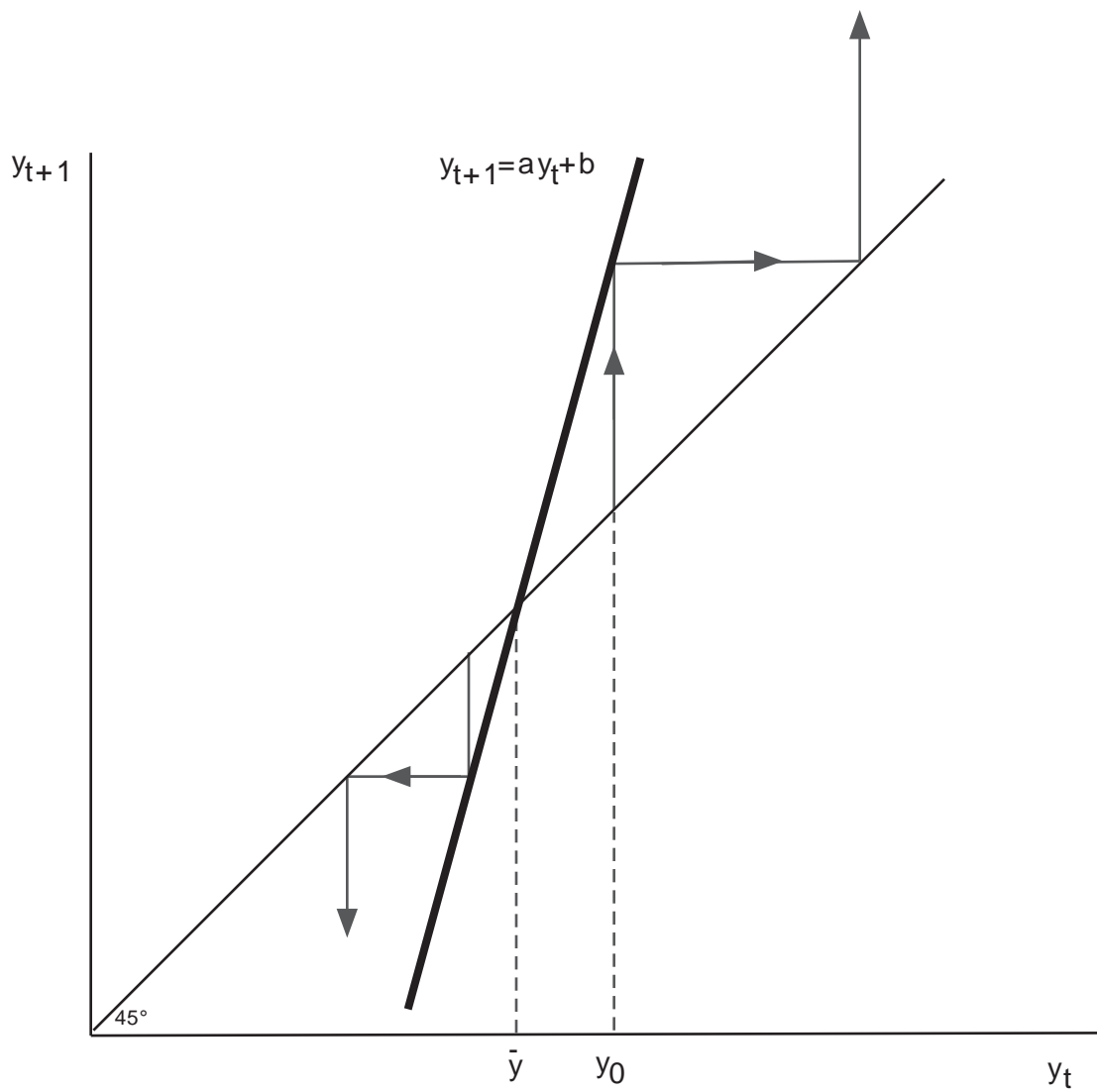

Figure 1.6

$a > 1$

Unique and Unstable Steady-State Equilibrium

(Monotonic Divergence)

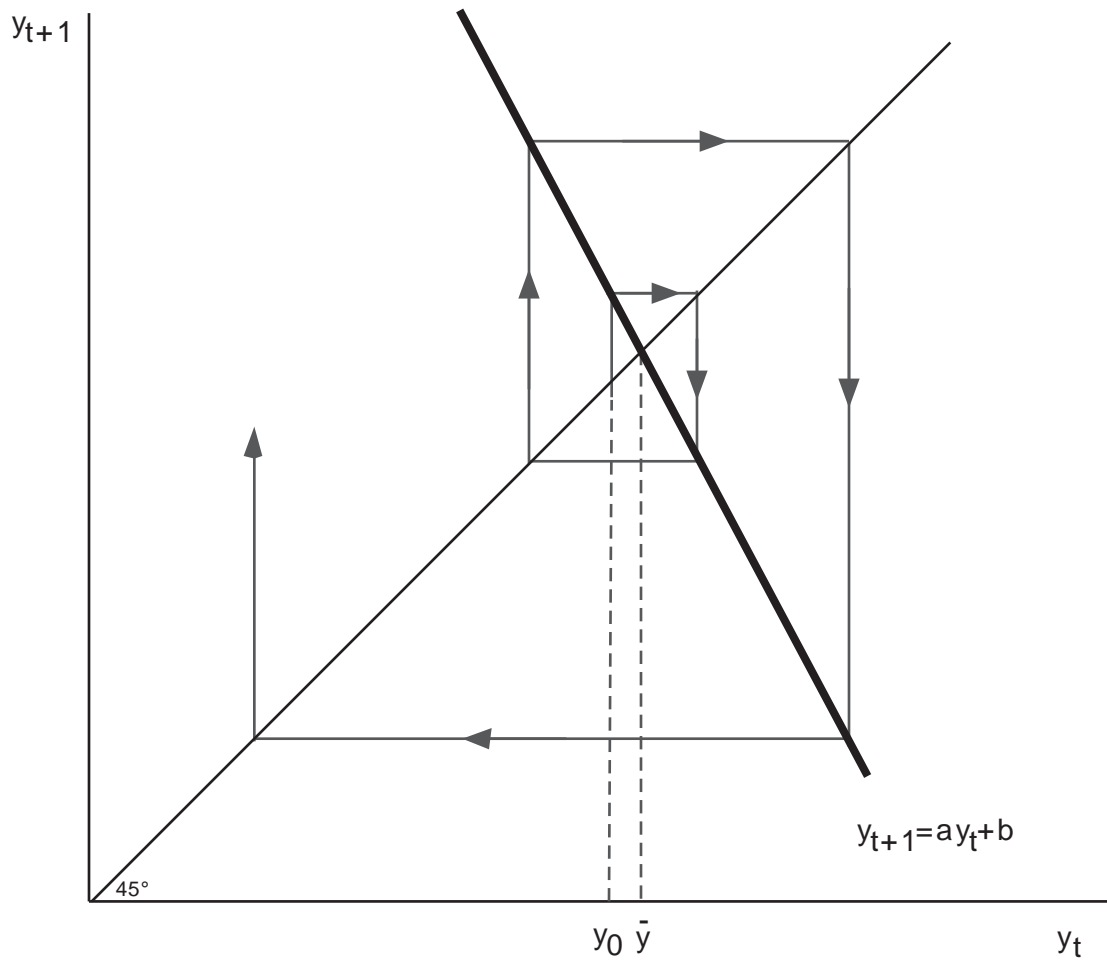

Figure 1.7

$$a < -1$$

Unique and Unstable Steady-State Equilibrium
(Oscillatory Divergence)

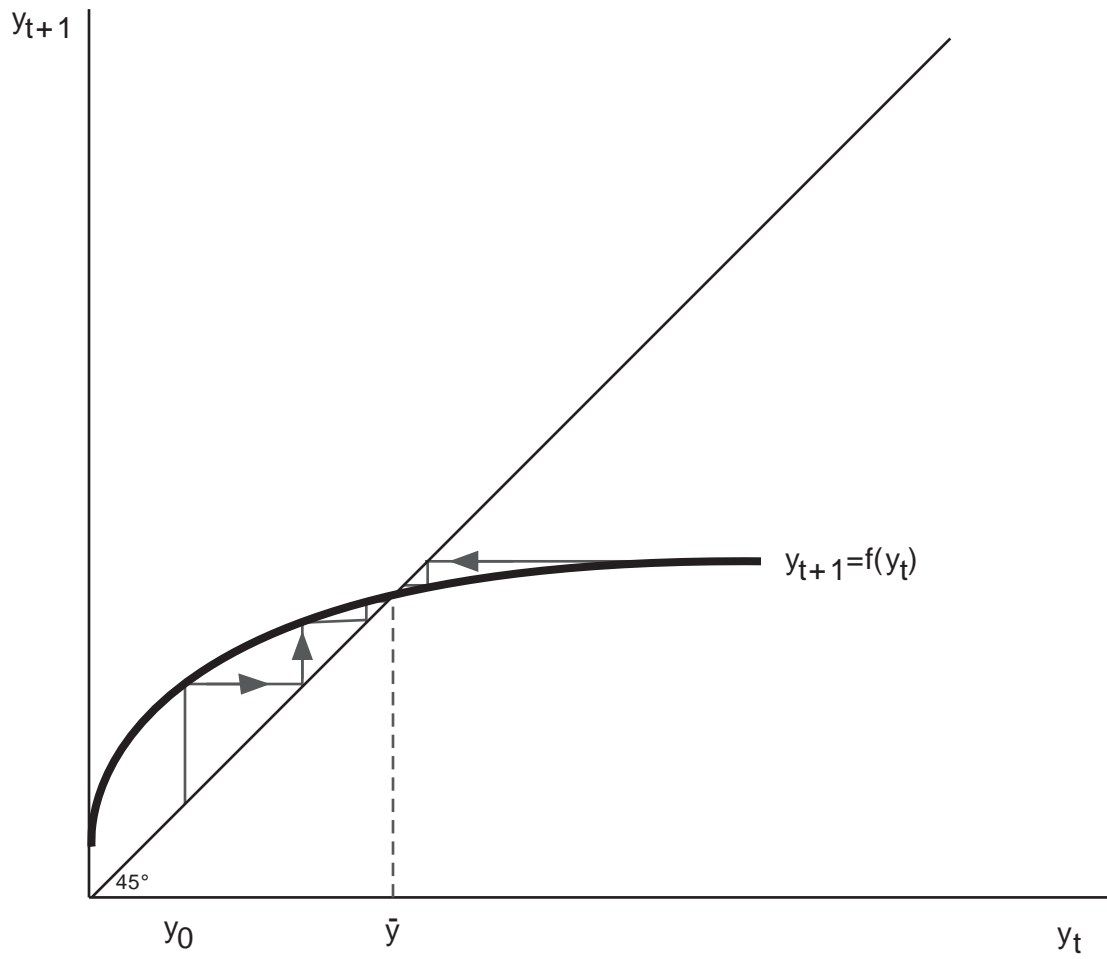

Figure 1.8

Unique and Globally Stable Steady-State Equilibrium

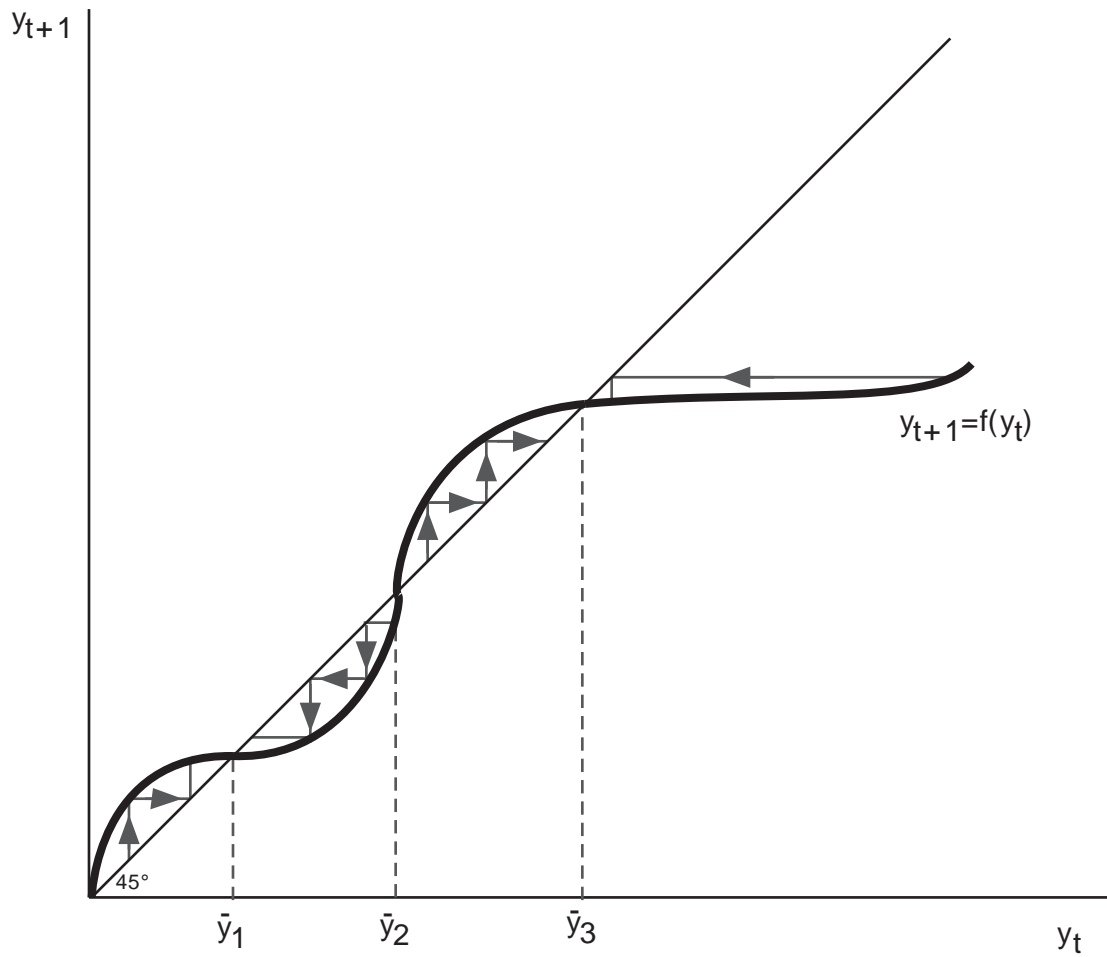

Figure 1.9

Multiple Locally Stable Steady-State Equilibria

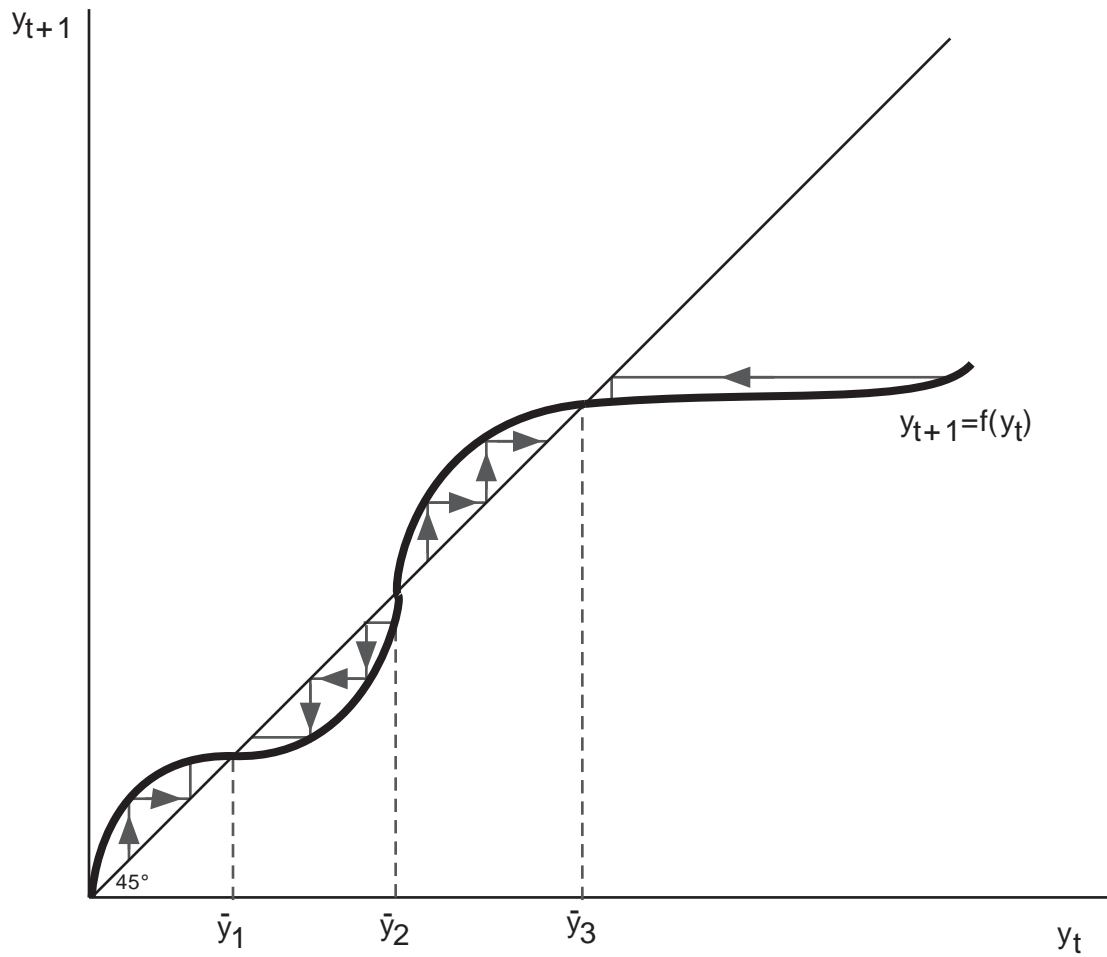

Figure 1.9

Multiple Locally Stable Steady-State Equilibria

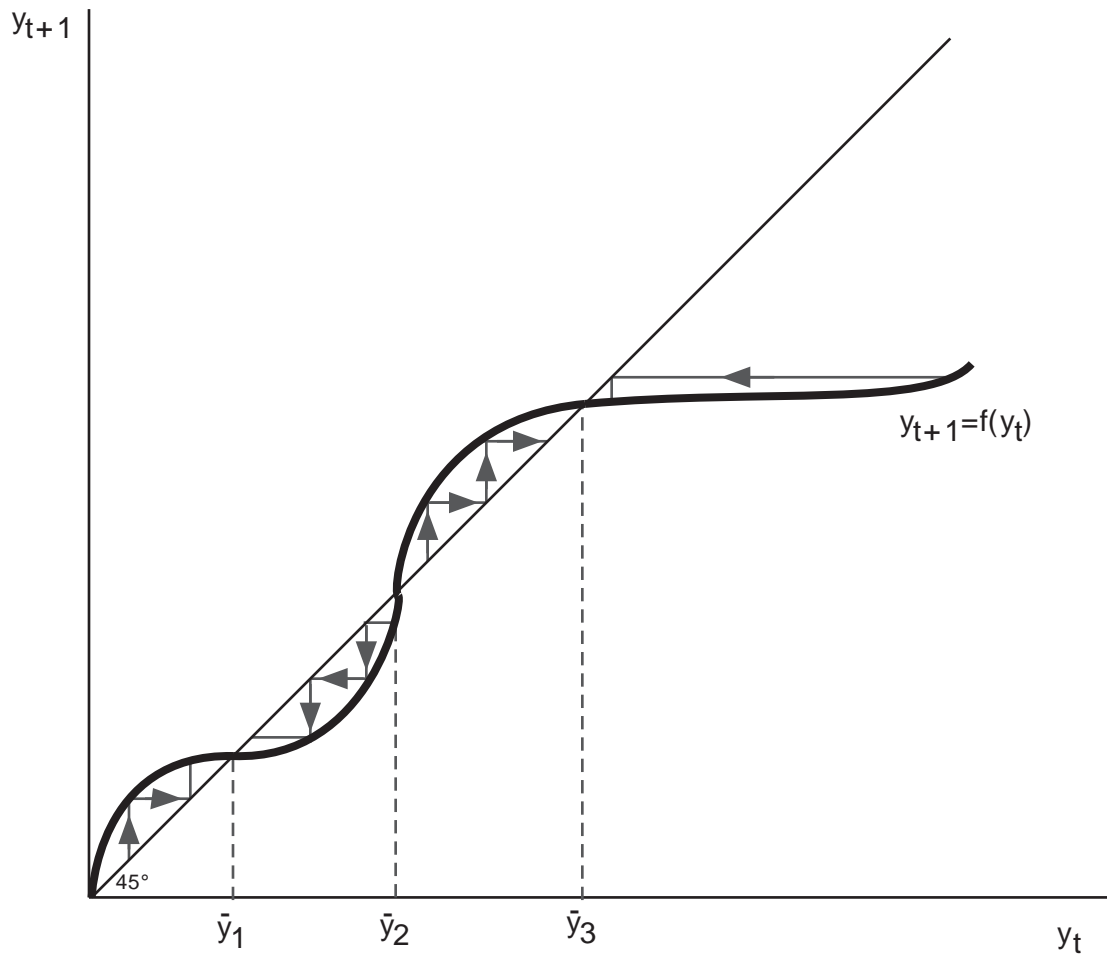

Figure 1.9

Multiple Locally Stable Steady-State Equilibria

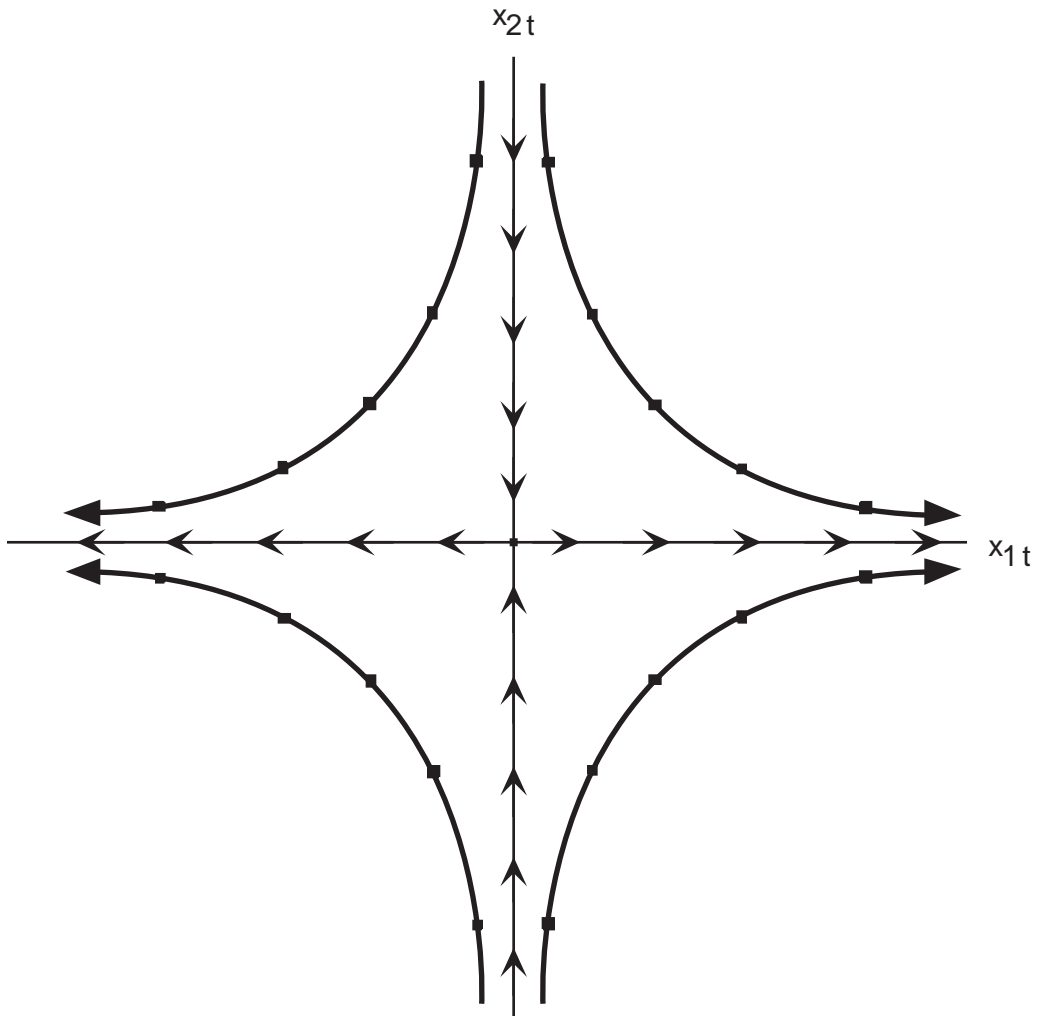

Figure 2.1
Saddle

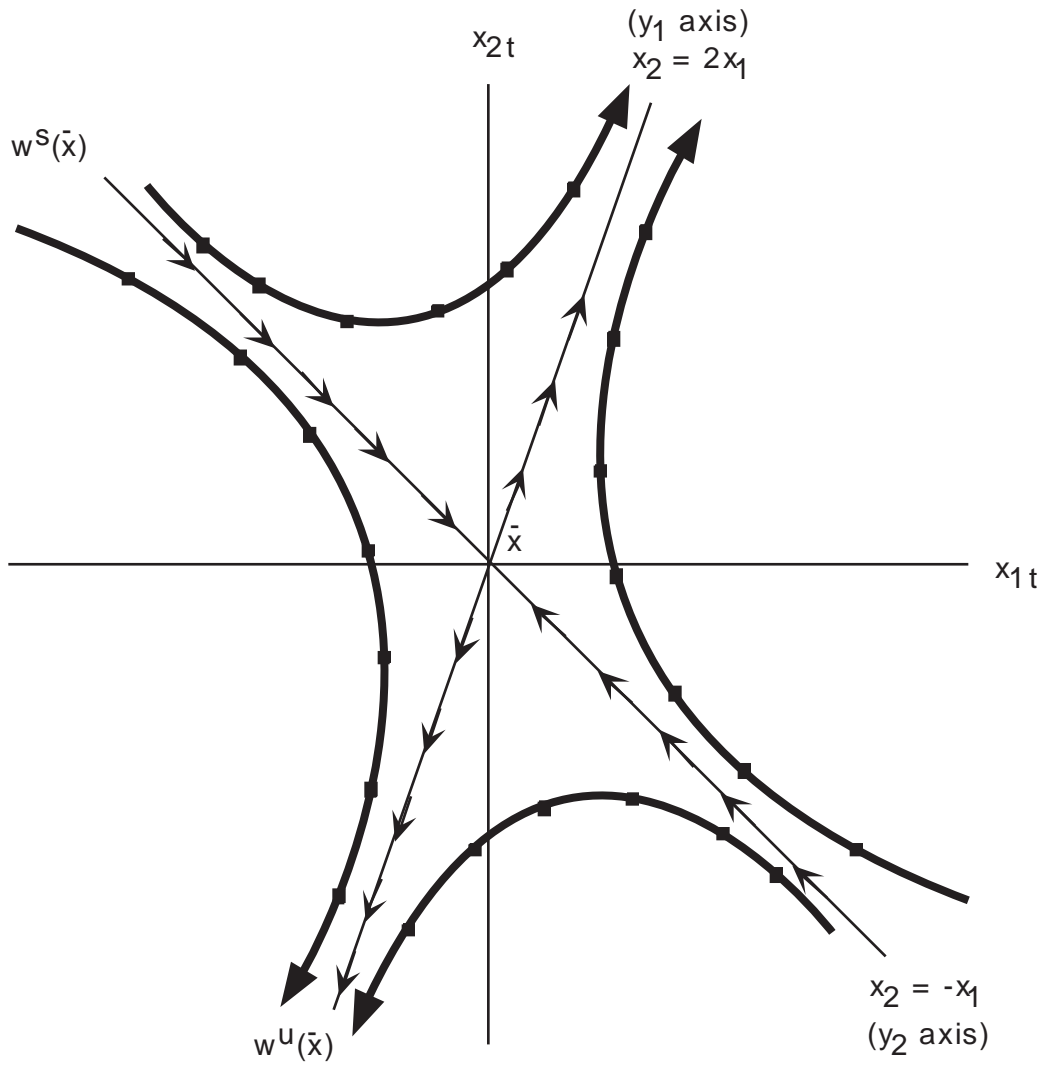

Figure 2.2

Saddle

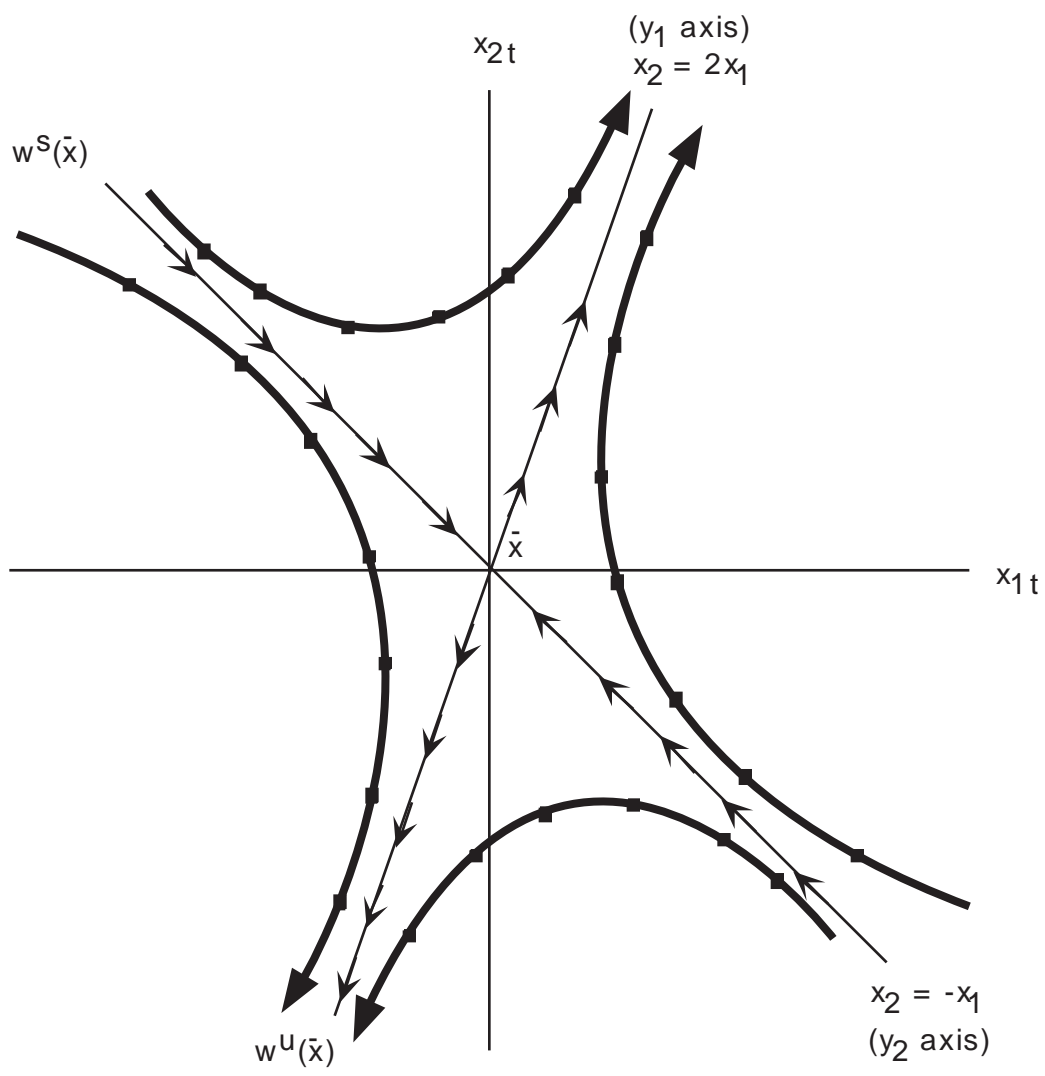

Figure 2.2

Saddle

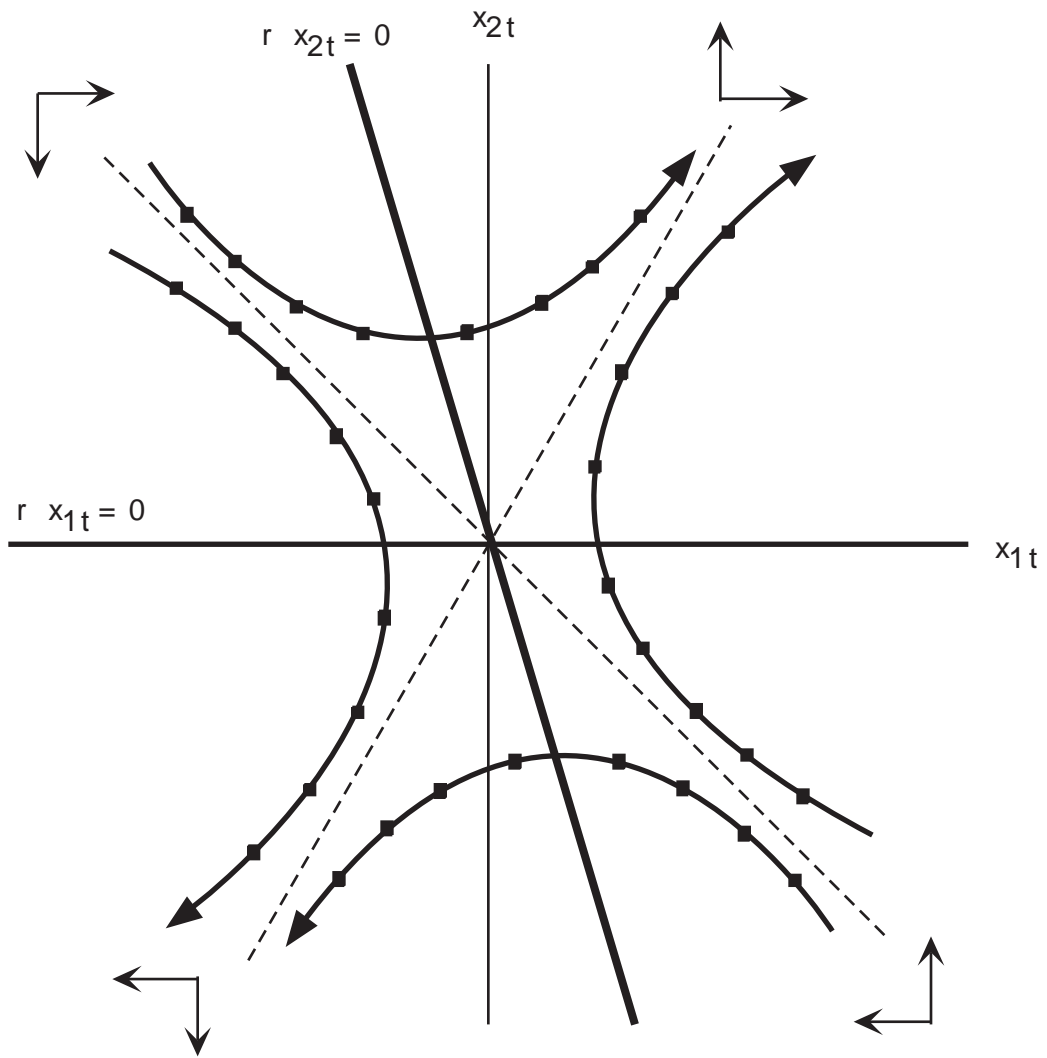

Figure 2.3

Phase Diagram Drawn without a Reference to an Explicit Solution

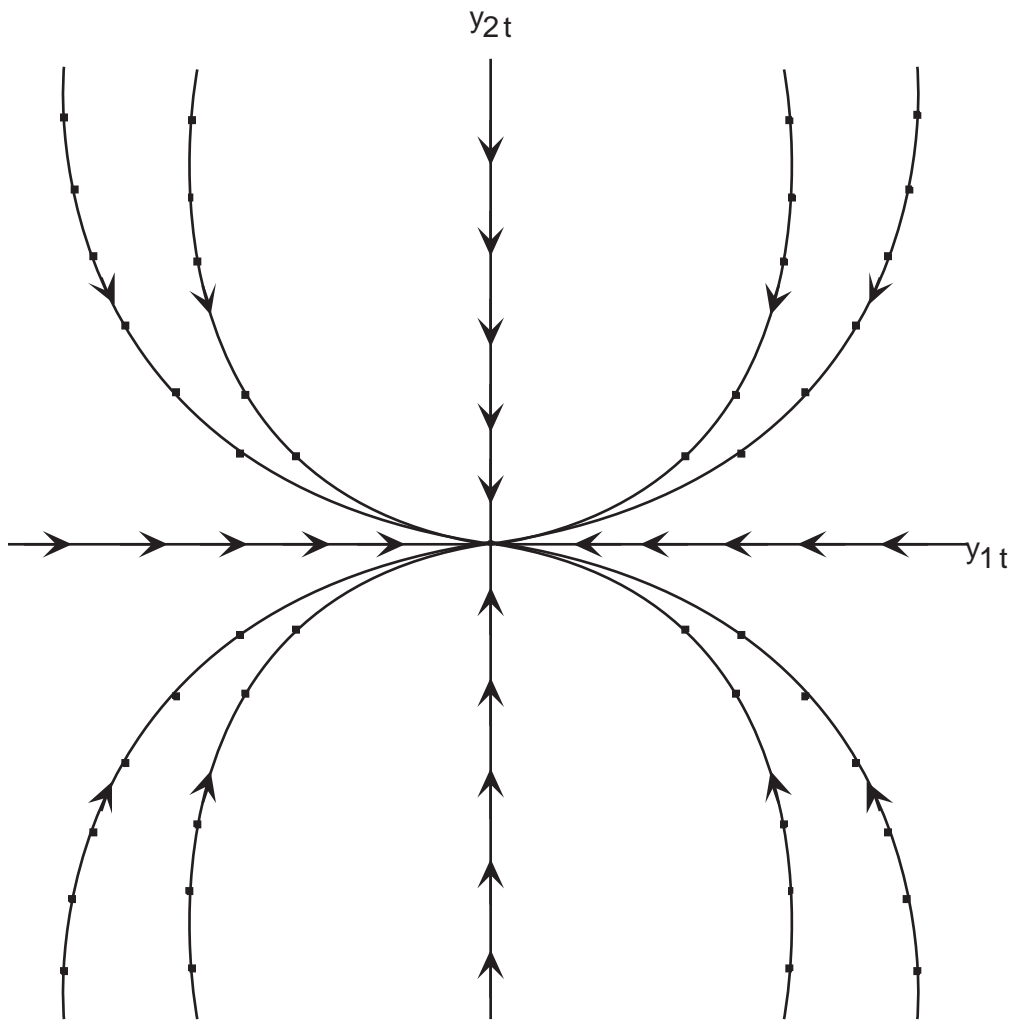

Figure 2.4 (a)

Stable Node

$$0 < \lambda_2 < \lambda_1 < 1$$

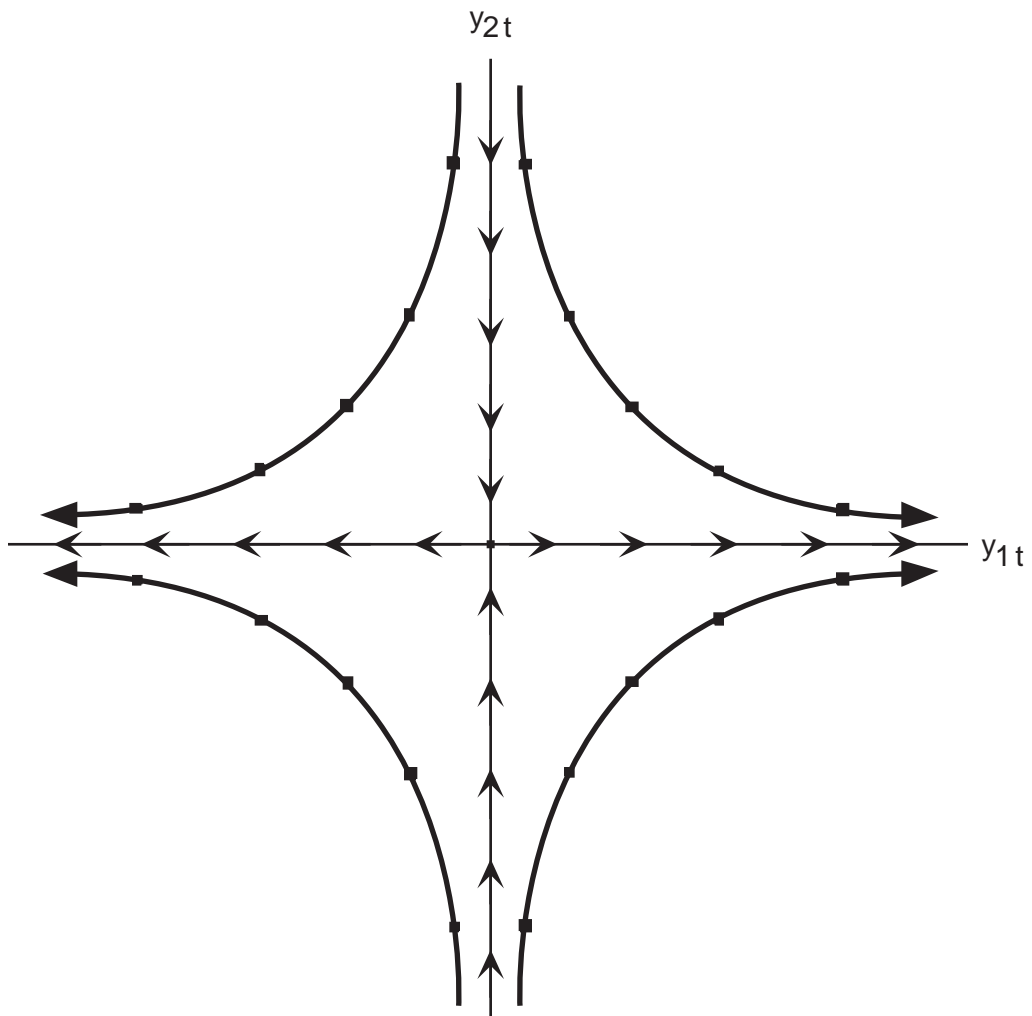

Figure 2.4(b)

$$0 < \lambda_2 < 1 < \lambda_1$$

Saddle

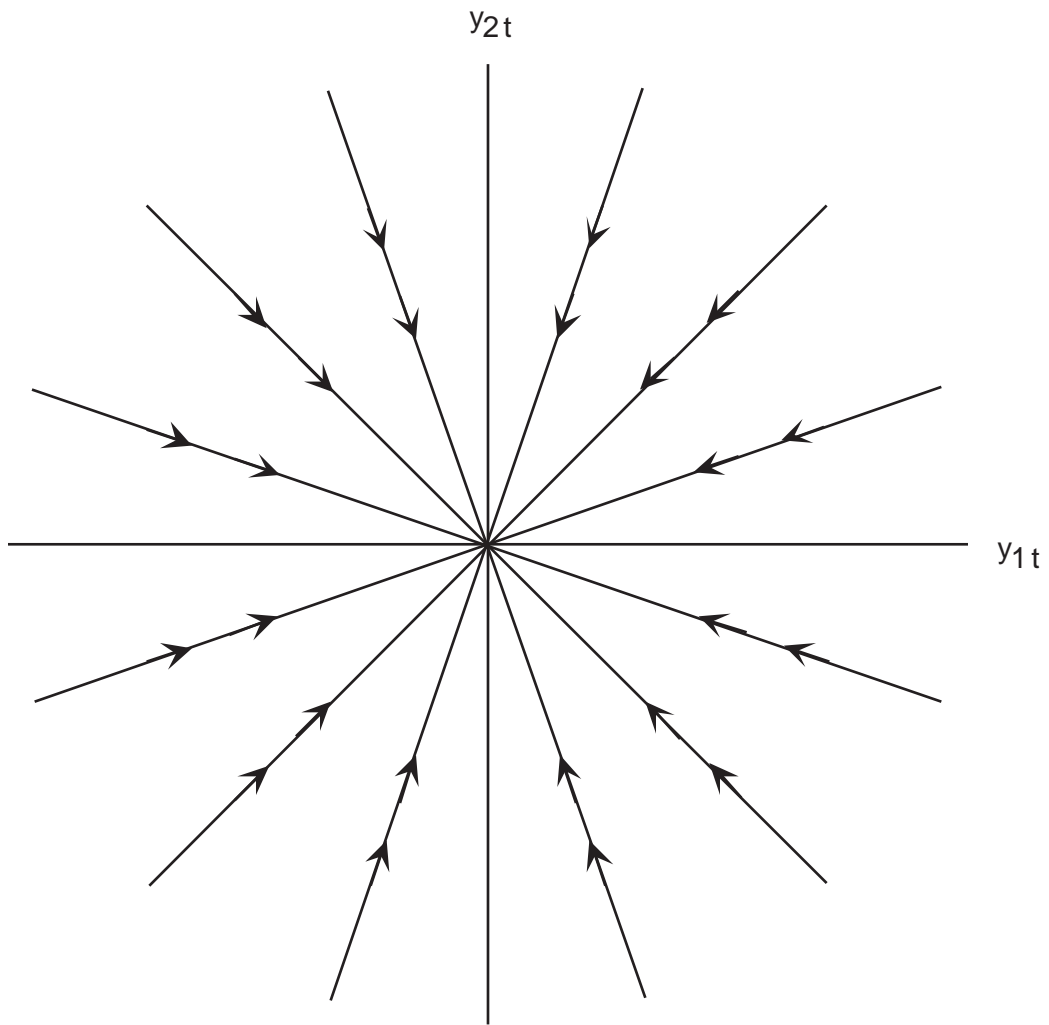

Figure 2.4(c)

$$0 < \lambda_2 = 1 < \lambda_1$$

Focus

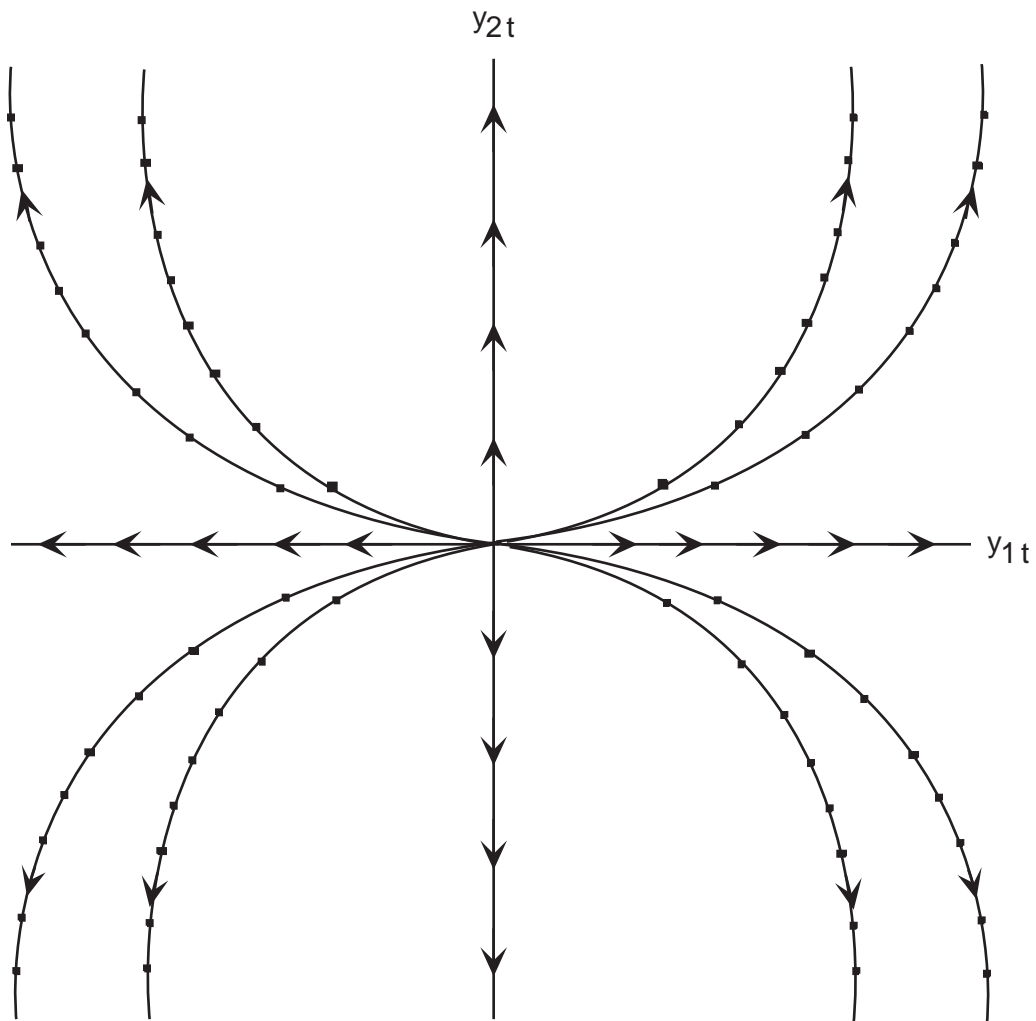
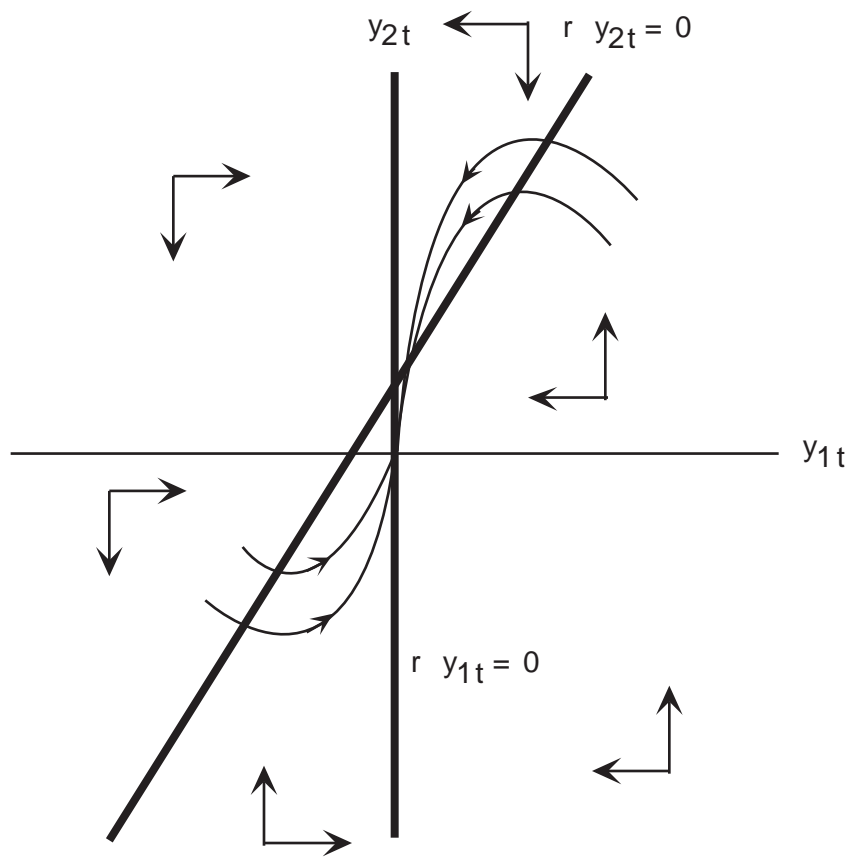

Figure 2.4 (d)

Source

$$1 < \lambda_1 < \lambda_2$$



$\lambda \in (0,1)$

Improper Node

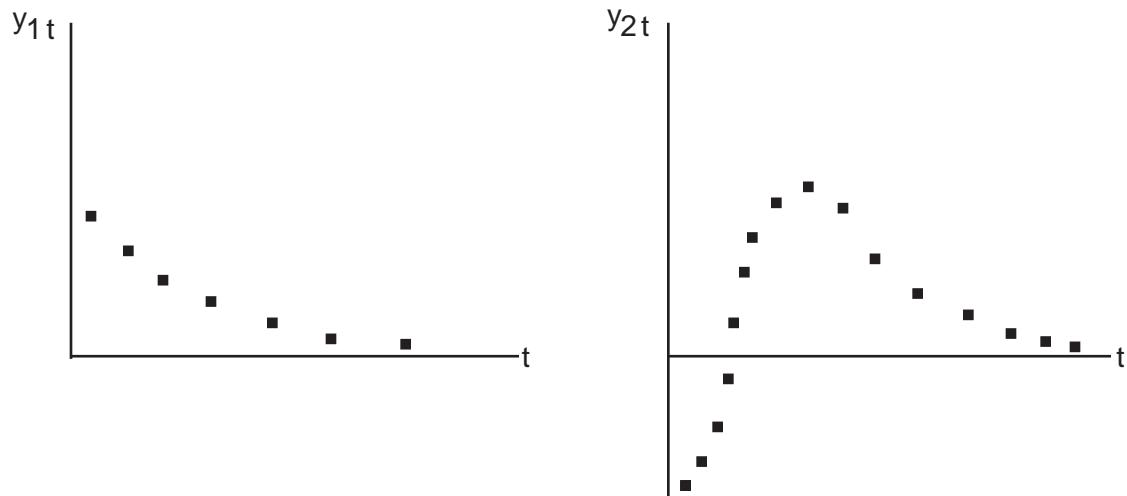

Figure 2.5 (a)

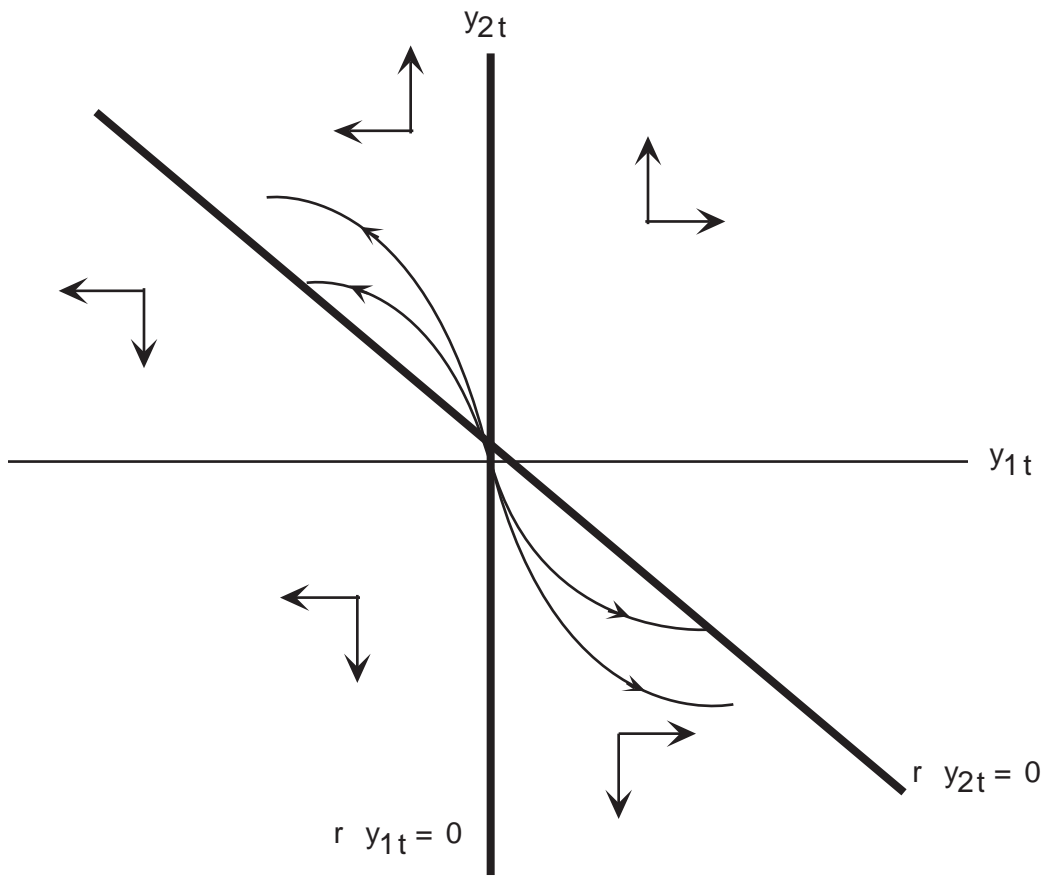

Figure 2.5(b)

$l \in (1, \infty)$

Improper Source

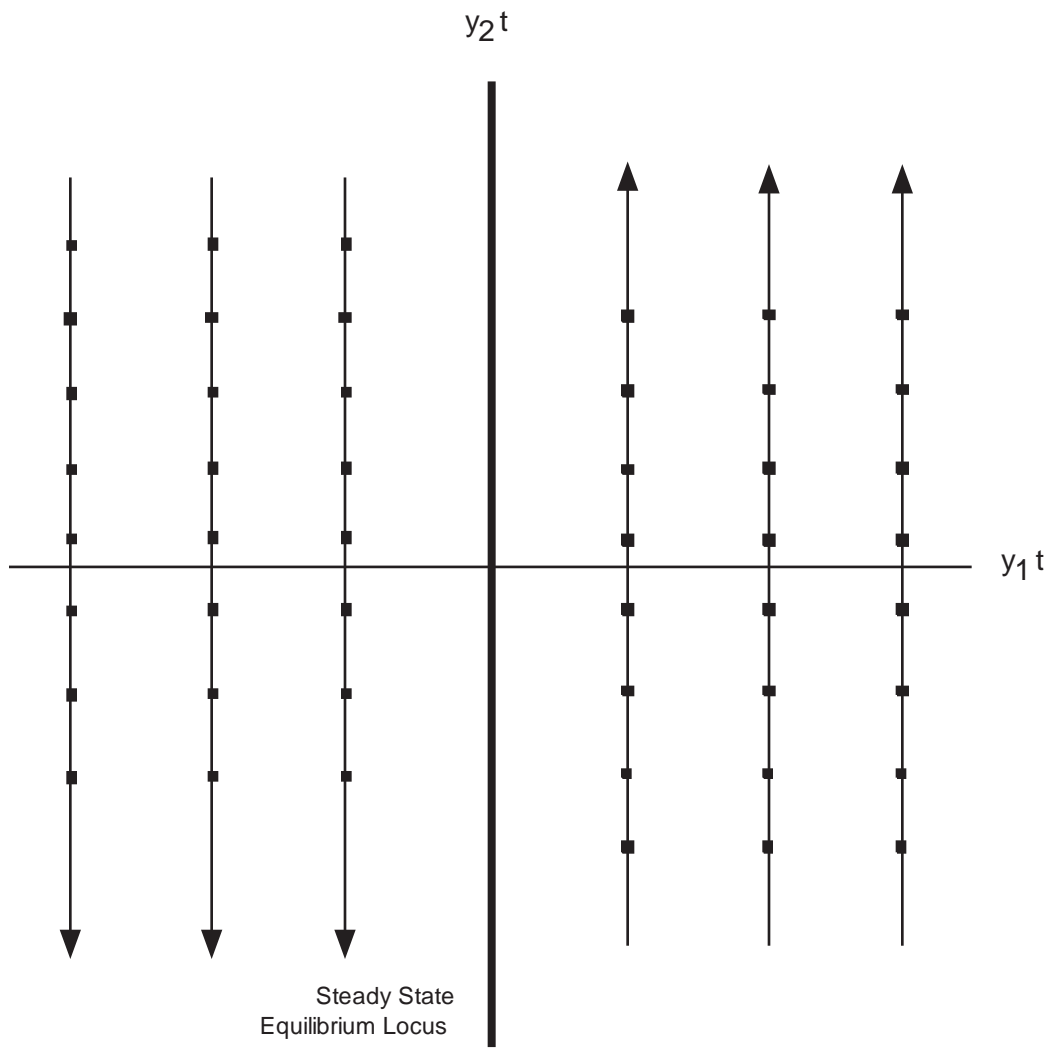

Figure 2.5(c)

$$\lambda=1$$

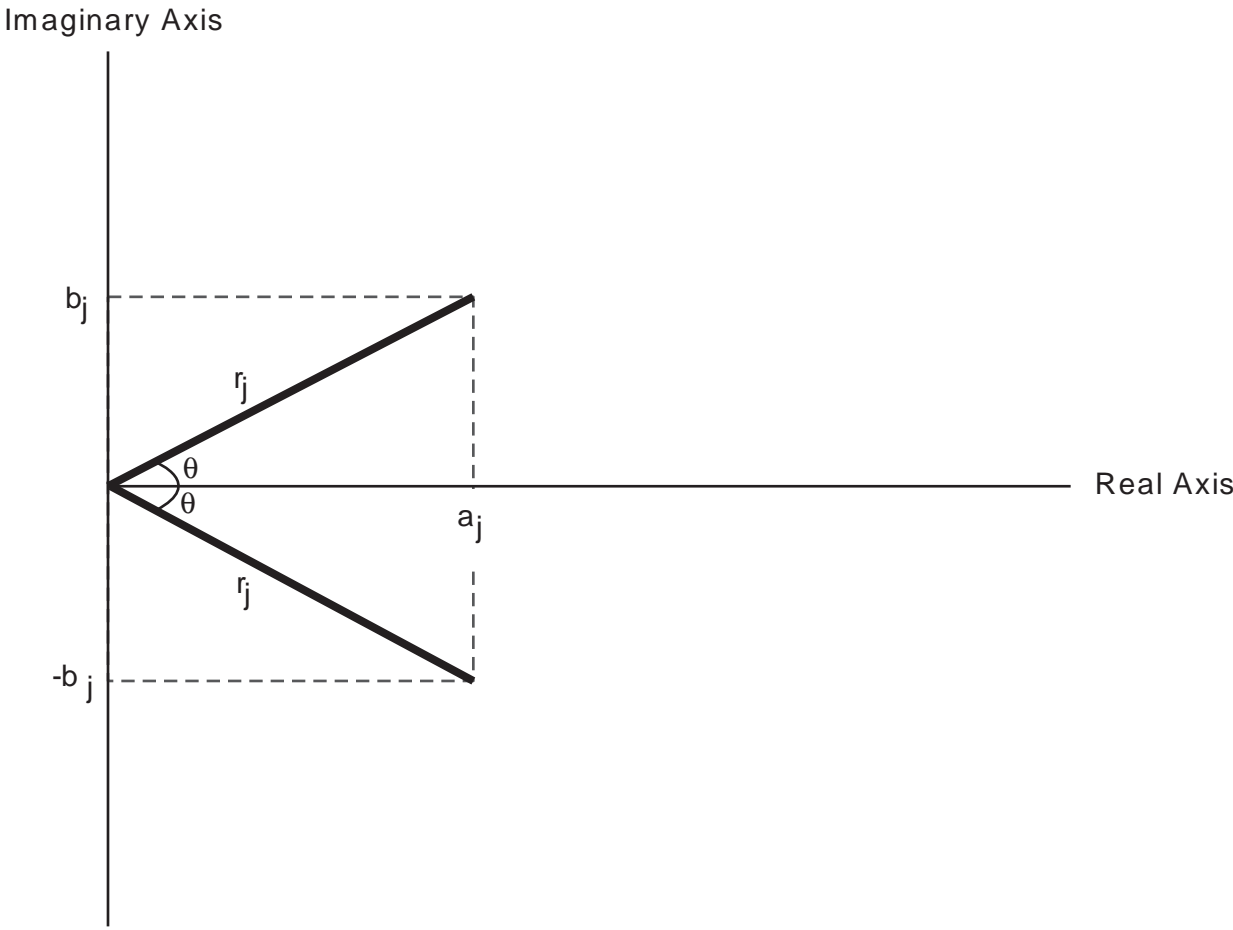

Figure 2.6

$$r_j \equiv (\alpha_j^2 + \beta_j^2)^{1/2}$$

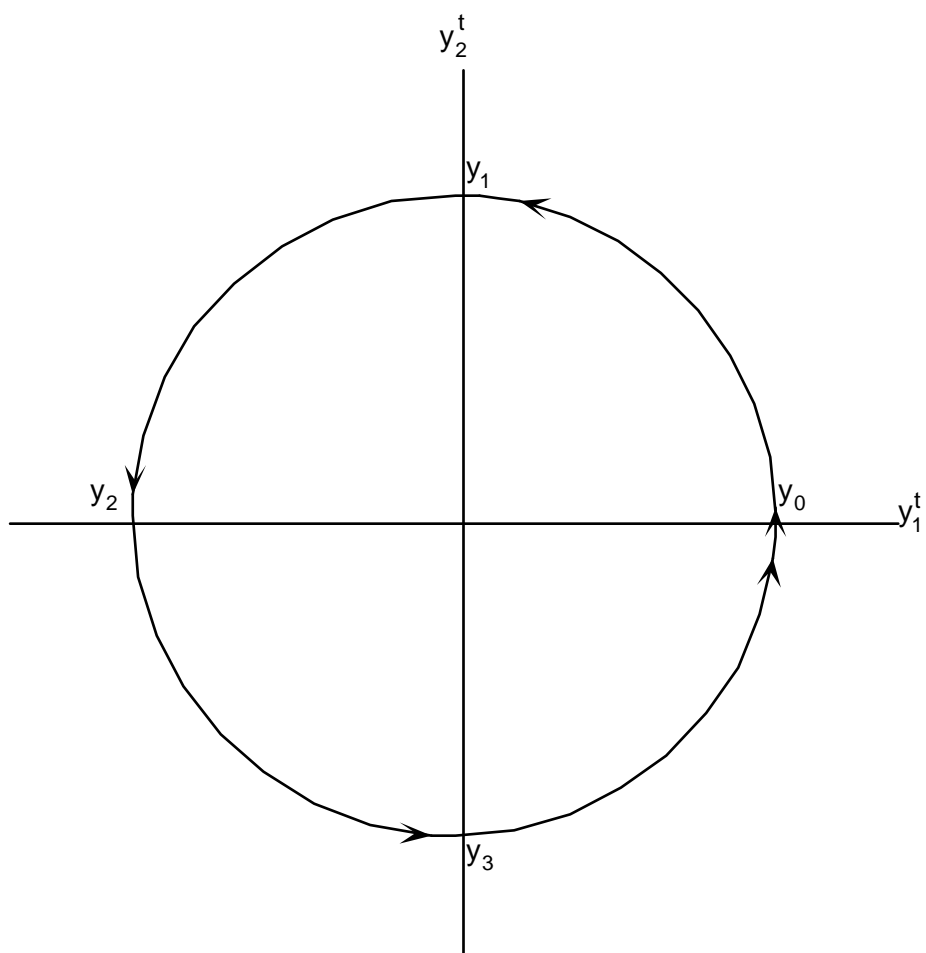

Figure 2.7 (a)

$$\rho=1 \quad \beta>0$$

Counter Clockwise Periodic Orbit

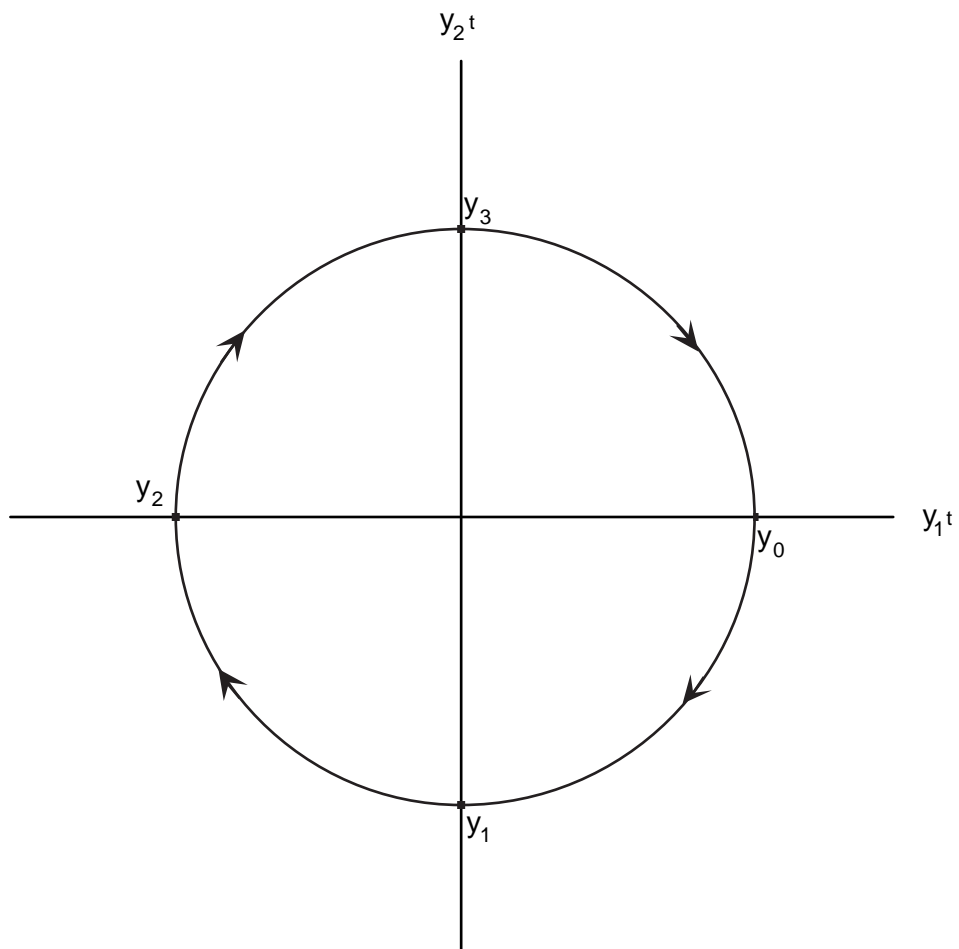

Figure 2.7 (b)

$$\rho=1 \quad \beta < 0$$

Clockwise Periodic Orbit

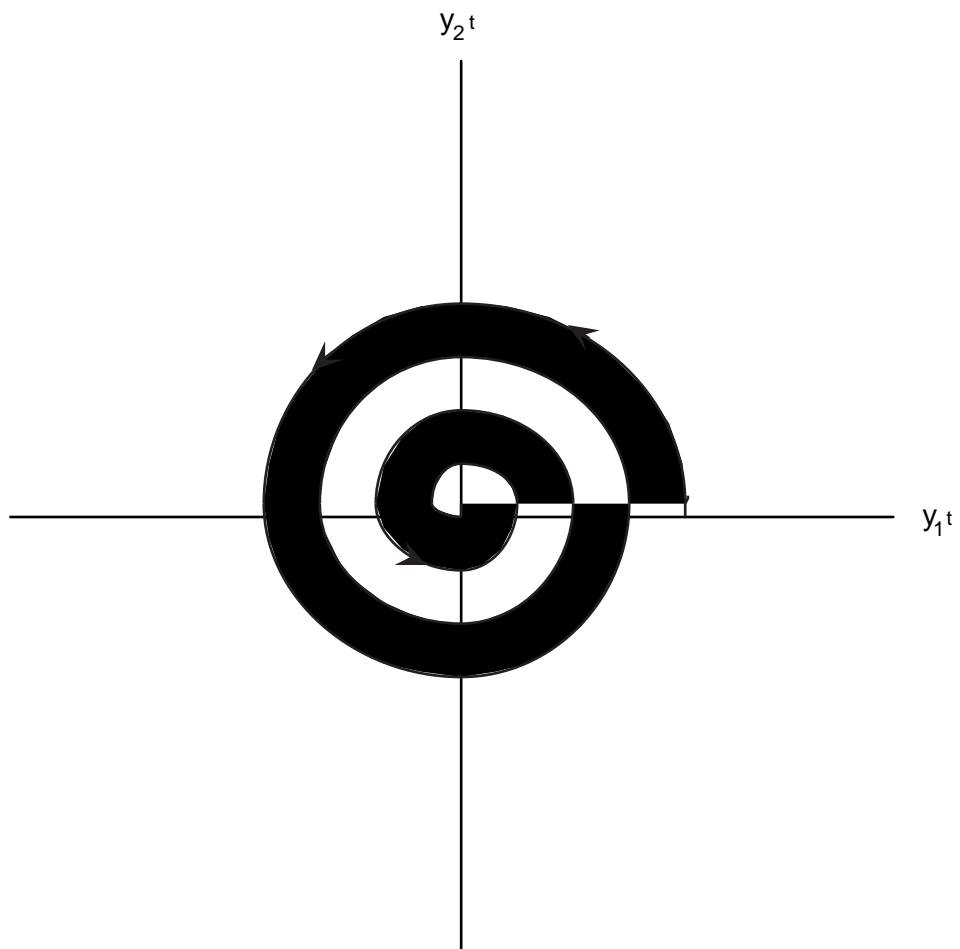

Figure 2.7 (c)

$$\rho < 1 \quad \beta > 0$$

Spiral Sink

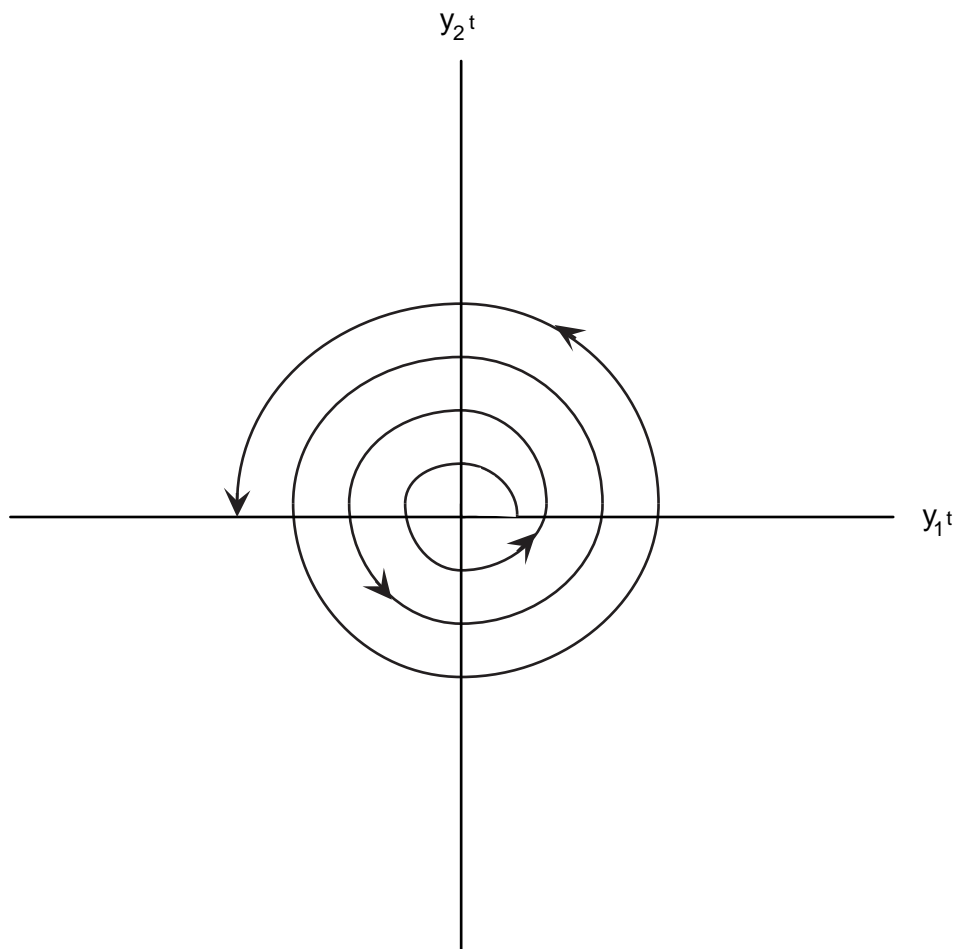

Figure 2.7 (d)

$\rho > 1$ & $\beta > 0$

Spiral Source

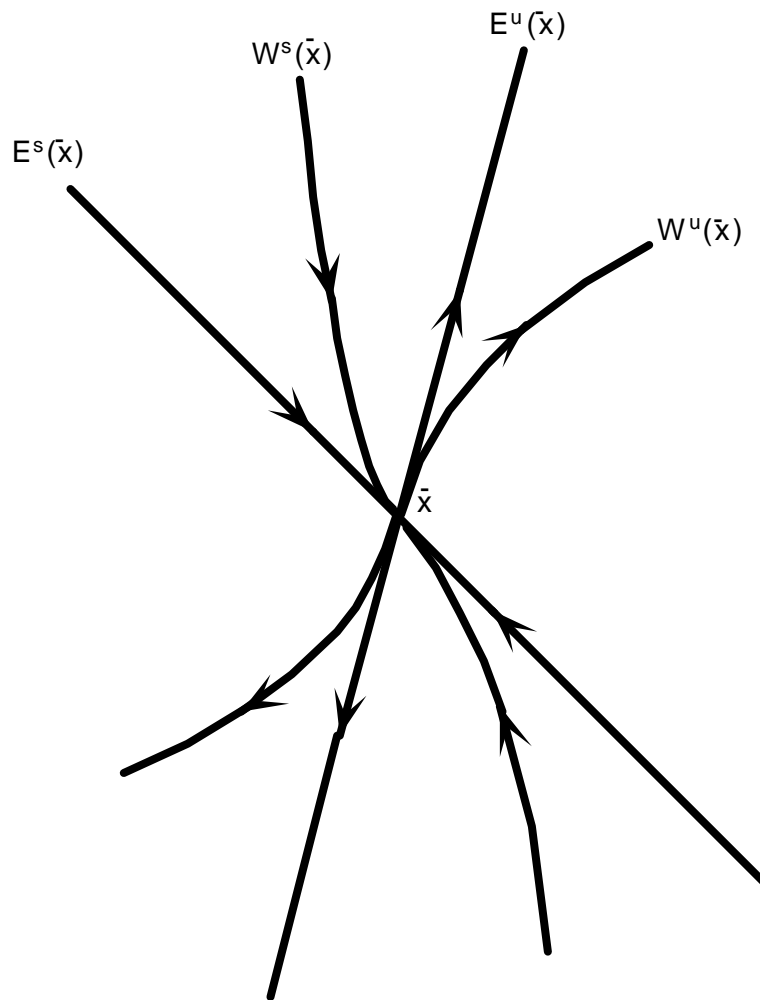

Figure 3.1

The stable and the unstable manifolds in relation
to the stable and unstable Eigenspaces

The Case of a Saddle