

**RESPONSE TO INCORPORATION OF SUPPLEMENTAL GONADOTROPINS
FOR DONOR AND RECIPIENT PROTOCOLS IN COMMERCIAL BOVINE
EMBRYO TRANSFER**

A Thesis

by

KELLEY CHRISTINE CHILES

Submitted to the Office of Graduate Studies of
Texas A&M University
in partial fulfillment of the requirements for the degree of

MASTER OF SCIENCE

May 2012

Major Subject: Physiology of Reproduction

**RESPONSE TO INCORPORATION OF SUPPLEMENTAL GONADOTROPINS
FOR DONOR AND RECIPIENT PROTOCOLS IN COMMERCIAL BOVINE
EMBRYO TRANSFER**

A Thesis

by

KELLEY CHRISTINE CHILES

Submitted to the Office of Graduate Studies of
Texas A&M University
in partial fulfillment of the requirements for the degree of

MASTER OF SCIENCE

Approved by:

Chair of Committee,	David W. Forrest
Committee Members,	Marcel Amstalden
	Charles R. Long
	Charles R. Looney
Head of Department,	Russell Cross

May 2012

Major Subject: Physiology of Reproduction

ABSTRACT

Response to Incorporation of Supplemental Gonadotropins for Donor and Recipient
Protocols in Commercial Bovine Embryo Transfer. (May 2012)

Kelley Christine Chiles, B.S., Texas A&M University

Chair of Advisory Committee: Dr. David Forrest

Superovulation of donor cows, embryo transfer, and estrus synchronization of recipients are widely used technologies in the purebred cattle industry. Progress continues to be made to achieve efficient and economic use of these technologies.

The first retrospective study was conducted to compare embryo production between a stimulation protocol using only Folltropin[®] as the gonadotropin, and a stimulation protocol using Folltropin[®] and Pluset[®]. Beefmaster donor cows (n=12) were stimulated using both protocols over two stimulated cycles, one protocol each cycle. Both protocols used the same synchronization protocol with only the gonadotropin injections differing. The control protocol (Folltropin[®] protocol) consisted of seven Folltropin[®] injections over the course of 3.5 days. The treatment protocol (Folltropin[®] + Pluset[®] protocol) consisted of four Folltropin[®] injections followed by three Pluset[®] injections over the course of 3.5 days. The mean numbers of viable embryos did not differ between treatments ($P > 0.01$) and were 9.33 and 6.58 for the control and treatment protocols, respectively. The proportion of viable embryos to total ova for each protocol was 0.49 and 0.48 for the control and treatment protocols, respectively ($P > 0.10$). No

significant difference on embryo production was observed between the control and treatment protocols.

The second retrospective study was performed to compare pregnancy rates after embryo transfer between Beefmaster recipients who received eCG during synchronization and recipients who did not receive eCG during synchronization. Due to the conditions of this study, statistical analysis could not be performed. Pregnancy rates are reported, but they are not statistically significant. Recipients in the control group (n=332) were synchronized with a protocol using a CIDR insert for seven days, a progesterone estradiol injection at the time of CIDR insertion, a prostaglandin (PG) injection at CIDR removal, and an estradiol injection the day after CIDR removal. Recipients in the treatment group (n=142) were synchronized using the same synchronization protocol as the control group, except eCG was administered five days after CIDR insertion. Pregnancy rates were 44.88 and 38.73 for the control and treatment groups, respectively. The addition of eCG to the synchronization protocol did not appear to be either beneficial or detrimental to pregnancy rate under the conditions of this study.

In summary, the addition of Pluset[®] to the stimulation protocol for donors was not detrimental to embryo production. The estrus synchronization protocol with eCG for recipients did not appear to be beneficial; however, a controlled studies are still warranted to further investigate the potential effects of recipient age, parity, body condition score, or breed effect on response to eCG.

DEDICATION

This thesis is dedicated to my family. To my mother who has always given me unconditional love and the support to make it through anything. To my father who has provided me with guidance and the confidence to make it on my own. To my brother who is a good-hearted person, and someone I am proud to call my brother.

ACKNOWLEDGEMENTS

I would like to thank my graduate committee members, Dr. David Forrest, Dr. Charles Looney, Dr. Marcel Amstalden, and Dr. Charles Long. Dr. Forrest provided me the opportunity to begin research in my undergraduate career and feedback and help throughout my time in the graduate program. Dr. Looney and the staff at OvaGenix for the opportunity to participate in research in the embryo transfer field. This research would not have been possible without him and his passion for research. I would also like thank Dr. Looney for sharing his knowledge about the embryo transfer industry. I would like to thank Dr. Amstalden for his feedback, and his help with the statistical analysis. Thank you also to Dr. Long for giving me the opportunity to participate in the in vitro production of embryos in his research lab. I would also like to thank Jane Pryor for sharing her knowledge of embryos and teaching me numerous laboratory techniques and laboratory maintenance. Thank you to El Lucero and Emerson Tijerina for providing me with the pregnancy status on the recipients used in this study.

TABLE OF CONTENTS

	Page
ABSTRACT	iii
DEDICATION.....	v
ACKNOWLEDGEMENTS	vi
TABLE OF CONTENTS	vii
LIST OF FIGURES	ix
LIST OF TABLES.....	x
 CHAPTER	
I INTRODUCTION AND REVIEW OF LITERATURE	1
Introduction	1
Induction of Superovulation	1
Gonadotropin-Dependent Follicular Growth	4
Effect of Stimulation Protocols on the Preovulatory LH Surge and Oocyte Maturation in Cattle.....	5
Manipulating Follicular Waves with Estradiol.....	7
Estrous Cycles: <i>Bos indicus</i> and <i>Bos taurus</i> Cattle	10
Equine Chorionic Gonadotropin.....	11
Use of eCG in Protocols for Estrus Synchronization	13
II SUPEROVULATION OF BEEF COWS WITH FOLLTROPIN [®] AND PLUSET [®]	17
Introduction	17
Materials and Methods.....	18
Results	22
Discussion	22
Implications	27
III ESTRUS SYNCHRONIZATION OF BEEF COW RECIPIENTS USING eCG	28
Introduction	28

CHAPTER	Page
Materials and Methods	29
Results	32
Discussion	35
Implications	38
IV CONCLUSIONS	40
LITERATURE CITED	42
VITA	48

LIST OF FIGURES

FIGURE		Page
1	Stimulation protocol for control group (Folltropin [®]).	19
2	Stimulation protocol for treatment group (Folltropin [®] + Pluset [®]).....	19
3	Synchronization protocol without eCG	30
4	Synchronization protocol with eCG	30

LIST OF TABLES

TABLE		Page
1	Mean (\pm SE) number of total ova, viable embryos, degenerate embryos, and unfertilized ova by treatment.	23
2	Mean (\pm SE) number of proportion of viable embryos to total ova and the transformed proportion by treatment.	24
3	Pregnancy rate reported for treatment, ET company responsible for freezing embryo, embryo stage, embryo grade, and total CL number	33
4	Mean total number of corpora lutea for recipients that did not receive eCG and recipients that did receive eCG	34

CHAPTER I

INTRODUCTION AND REVIEW OF LITERATURE

Introduction

Superovulation, embryo transfer, and estrus synchronization are widely used technologies in the purebred cattle industry. Continued progress towards the optimization of embryo yield and quality, and improvements in pregnancy rates are required for the efficient and economical use of these technologies. Adequate hormonal therapies that support a large number of ovulatory follicles to develop are critical for successful superovulation procedures in both cows and heifers. However, many breeds of cattle, in particular *Bos indicus*-influenced breeds, may show varied responsiveness to the hormones used for superovulation (Bo et al., 2010). Many synchronization protocols exist for recipient cows, but some protocols may be more beneficial when used in *Bos indicus*-influenced recipients than others (Nasser et al., 2004, Baruselli et al., 2010).

Induction of Superovulation

Cattle are polyestrous, with an estrous cycle (21 d on average) occurring regularly throughout the year. The bovine estrous cycle is broken into two phases consisting of the follicular phase (20% of the estrous cycle) and the luteal phase (80% of the estrous

This thesis follows the style of Journal of Animal Science.

cycle). The follicular phase starts after luteolysis, when progesterone is low, and ends at ovulation. During the follicular phase, gonadotropins are secreted causing continued follicular growth and increased estrogen production from the follicle. The luteal phase starts after ovulation, continues through the development of the corpus luteum (CL), and ends after luteolysis. During the luteal phase, the CL develops and secretes increasing amounts of progesterone, with the peak of progesterone secretion occurring after the CL becomes fully functional. Follicular waves will occur throughout the estrous cycle with luteinization of the follicle and ovulation occurring only after luteolysis when progesterone is low (reviewed by Senger, 2003). A follicular wave is characterized by a synchronous growth of a cohort of small follicles, and is preceded by a rise in plasma FSH 1 to 2 d before emergence (Adams, 1994). Cattle have been reported to exhibit two-wave and three-wave estrous cycles. After selection of the dominant follicle, the subordinate follicles undergo atresia and new follicular waves are prevented by the suppression of FSH caused by the dominant follicle (Adams, 1994). The induction of superovulation, and continued growth of multiple follicles, in cattle can be achieved with administration of exogenous gonadotropins, usually follicle stimulating hormone (FSH). Gonadotropin treatment can be initiated on the first follicular wave emergence with no difference in response observed when compared to gonadotropin treatment initiated on the second follicular wave (Adams et al., 1994). Adams et al. (1994) also noted that treatment with gonadotropins, particularly FSH, early in follicular wave emergence is more important than which wave (first or second) the treatment is initiated. The ovulatory response is increased when FSH is administered beginning the day before, or

the day of, follicular wave emergence (Bo et al., 1995). The purity of the FSH preparation administered is also important. Numerous studies have reported a lower percentage of transferrable embryos are produced when the LH content of an FSH preparation is increased compared to a more purified FSH preparation (reviewed by Mapletoft et al., 2002).

FSH is typically administered twice-daily over 4 to 5 d in decreasing doses to stimulate follicular development in cattle (reviewed by Bo et al., 2010). Other protocols involving single injections and once-daily injections of FSH have also been used; with varying results. A single subcutaneous injection of Folltropin[®] yielded a response comparable to twice-daily intramuscular injections of Folltropin[®] (Bo et al., 1991, Bo et al., 1994, Schallenberger et al., 1994) in beef cows with a good body condition score, but not in dairy cows (Lovie et al., 1994). Lovie et al. (1994) reported that dividing Folltropin[®] into two subcutaneous doses can improve superstimulatory response compared to a single subcutaneous dose, but multiple intramuscular injections still yield the best superstimulatory responses. Single subcutaneous doses of Folltropin[®] have been reported to have inconsistent superstimulatory responses among different breeds and body condition scores, which can be attributed to varying amounts of subcutaneous fat depending on breed and parity (Lovie et al., 1994, Bo et al., 1994). The single subcutaneous injection of Folltropin[®] is not used in the commercial embryo transfer industry today due to the inconsistent superstimulatory response generated. Other protocols using once-daily injections of FSH for 4 days have reported superstimulatory responses and transferable embryo results similar to the more traditional twice-daily

injections (Kanitz et al., 2002). However, others have found twice-daily injections to be superior to once-daily injections (Walsh et al., 1993). A twice-daily injection of FSH for 4 days is the most common stimulatory protocol currently used in the commercial ET industry (Bo et al., 2010). To optimize superstimulatory response in cattle, it is necessary to initiate exogenous FSH administration the day before (or the day of) follicular wave emergence, and continue to administer FSH twice-daily during the stimulation protocol.

Gonadotropin-Dependent Follicular Growth

Antral follicles become dependent on FSH at approximately 4 mm, and require elevated FSH levels for their continued growth and steroid production (reviewed by Mihm and Bleach, 2003). Mihm and Bleach (2003) explained that these follicles will continue to produce estradiol and inhibin which will reduce FSH secretion and results in selection of the dominant follicle. After selection, the dominant follicle switches from FSH dependency to LH dependency, requiring LH for continued growth and steroidogenesis (Mihm and Bleach, 2003).

Gene expression for FSH receptors and LH receptors has been studied during development of the dominant follicle. During the anovulatory follicular wave in cattle, as the dominant follicle grows its dependence on FSH decreases as its dependence on LH increases (Mihm et al., 2006). Mihm et al. (2006) found mRNA expression for the FSH receptor in granulosa cells decreased as mRNA expression for the LH receptor increased during dominant follicle growth. The authors suggested this provides

molecular evidence that the dominant follicle does not depend completely on FSH and LH plays a role for continued growth of the dominant follicle as serum concentrations of FSH decrease while pulsatile frequency of LH secretion increases. In Nelore cows, an increase in LH receptor gene expression was observed in granulosa cells, but not in theca cells, as follicle diameter increased (Simões et al., 2011). Simões et al. (2011) reported a high ovulation rate (90%) in follicles larger than 10 mm when exogenous LH was administered. The high ovulatory rate was attributed to the increased amount of LH receptor gene expression in the granulosa cells of follicles greater than 10 mm.

Effect of Stimulation Protocols on the Preovulatory LH Surge and Oocyte

Maturation in Cattle

A sufficient preovulatory surge of LH is necessary to cause ovulation in dominant follicles that have acquired the capacity to luteinize in response to LH. Without an adequate preovulatory LH surge, ovulation of capable follicles will not occur. This is important in superovulation of donor cows because ovulation of the stimulated follicles needs to occur to allow for fertilization of the ova and the subsequent embryo collection. The mean interval from the induction of luteolysis (first PGF_{2α} injection) to the preovulatory LH surge when cows were stimulated with FSH has been reported to be 46.5 ± 4.4 h with ovulations starting between 62 to 68 h after PGF_{2α}, and an interval of 1.2 to 12 h from the first to last ovulations (reviewed by Kanitz et al., 2002). The interval, up to 12 h, between the first to last ovulations indicates the need for multiple inseminations to maximize fertilization rates (reviewed by Kanitz et al., 2002).

Ovarian stimulation in *Bos indicus* females has been shown to decrease the intervals from CIDR removal to the preovulatory LH surge. When estrous synchronization was performed, Nelore cows had a preovulatory LH surge 46.7 ± 4.9 h after CIDR removal with ovulation beginning 25.6 ± 7.4 h after the preovulatory surge (Monteiro et al., 2009). These same Nelore cows were then stimulated with Folltropin[®] and had a preovulatory LH surge 34.6 ± 1.6 h after CIDR removal with ovulation occurring 24.9 ± 1.6 h after the LH surge. Monteiro et al. (2009) suggested that the 12 h difference in the interval from CIDR removal to the preovulatory LH surge may be due to a higher level of plasma estradiol as a result of the increase in follicles from the superovulatory treatment.

The follicular fluid in unstimulated cattle before the LH peak contains a high concentration of estradiol (E2); this concentration decreases within the first 10-12 h after the peak of the LH surge and remains low until approximately 24 h after the peak of the LH surge when ovulation occurs (Dieleman et al., 1983, Hyttel et al., 1991). The progesterone (P4) concentration in the follicular fluid follows a different pattern than E2. Before the LH peak P4 is low, rises during the surge, and decreases 4-6 h after the peak; a dramatic increase in P4 occurs 20-24 h after the peak (Dieleman et al., 1983, Hyttel et al., 1991). Within 4-8 h after the LH peak, meiosis resumes (characterized by germinal vesicle breakdown). Metaphase I is observed in oocytes within 19 h after the LH peak, with most oocytes reaching metaphase II 19-25 h after the LH peak (Hyttel et al., 1991). In superovulated cattle, follicular steroidogenesis was similar to unstimulated cattle, but there was more variation in the rate of oocyte maturation in superovulated cattle when

compared to their unstimulated counterparts (Dieleman et al., 1983, Kruip et al., 1983, Hyttel et al., 1991). Hyttel et al. (1991) found that superovulated animals that lacked the LH surge experienced a large proportion of premature oocyte maturation which was attributed to the LH content of the eCG and FSH preparations. An increase in the frequency of oocytes that began maturation but were arrested in diakinesis or metaphase I was also observed in stimulated cattle (Hyttel et al., 1991). While ovarian stimulation does not appear to have an effect on follicular steroidogenesis, it does appear to have an impact on oocyte maturation.

Manipulating Follicular Waves with Estradiol

Estradiol has been used in many synchronization programs for fixed-time AI (FTAI), fixed-time embryo transfer (FTET), and even in synchronization programs for superovulated donors. The common forms of estradiol used include estradiol-17 β (E-17 β), estradiol benzoate (EB), and estradiol valerate (EV). Estradiol is used to induce the emergence of a new follicular wave and to synchronize ovulation (Martínez et al., 2005, Martínez et al., 2007). Embryo quality can also be improved when follicular wave emergence is induced using hormones, such as progesterone and estradiol, or follicle ablation (Bo et al., 1995).

The administration of E-17 β has a suppressive effect on FSH release for about 48 h, which causes the FSH-dependent follicles to undergo atresia (Martínez et al., 2005, Martínez et al., 2007, Bo et al., 1995). Plasma FSH concentration begins to rise above pretreatment levels approximately 60 h after E-17 β treatment, and a new follicular wave

emerges approximately 1 d after the increase in plasma FSH above pretreatment levels (Martínez et al., 2005). Administration of exogenous estradiol has also been shown to have an atretic effect on follicles (reviewed by Dierschke et al., 1994). Increased androgen production, reduced progesterone and estrogen production, a reduced number of granulosa cells, and degenerated oocytes (all markers of atresia) have all been observed in follicles when exogenous estradiol has been administered; these markers of atresia were still observed even when FSH and LH were administered in conjunction with estradiol. Estradiol has been shown to have a biphasic effect on LH secretion. Initially, a surge of LH occurring approximately 24 h after E-17 β administration is observed, followed by a decrease in LH secretion and a return to nadir 72 h after treatment (Martínez et al., 2007). The LH surge could be attributed to the inability of progesterone, administered in conjunction with E-17 β , to effectively block the release of LH during the high concentration of plasma estradiol which occurs within 2 h of E-17 β administration. The suppression of LH can be attributed to the synergistic effects of progesterone, which decreases LH pulse frequency; and estradiol, which decreases LH pulse amplitude (Price et al., 1999). Gonadotropins must be suppressed for at least 24 h for complete dominant follicle regression to occur and a new follicular wave to emerge (Bo et al., 1995).

The interval from hormone administration to new follicular wave emergence depends on the form of estradiol used. Following administration of 5 mg of E-17 β , EB, or EV, a new follicular wave emerges on average 4.3 d later (Bo et al., 1995), 5.4 d later (Bó et al., 1998), and 5.7 d later (Mapletoft et al., 1999), respectively. When just 1 mg

of EB is used, a new follicular wave will emerge at a time similar to that of E-17 β because the suppression of FSH is shorter and more similar to E-17 β (Martínez et al., 2005). When GnRH is administered a new follicular wave emerges on average 2 d later, but the interval is more variable than the interval following estradiol/progesterone administration (Martinez et al., 2000). The variability in interval to follicular wave emergence in response to GnRH is related to the stage of the dominant follicle at the time of GnRH administration. An emergence of a new follicular wave does not occur if ovulation of the dominant follicle does not occur after treatment with GnRH (Martinez et al., 1999). Follicles must reach a certain size to be responsive to the GnRH treatment. Martinez et al. (1999) reported that ovulation in response to GnRH occurred in all heifers where the largest follicle was 9-10 mm in diameter.

A CIDR, or other progesterone releasing device, is usually incorporated in these synchronization programs, and progesterone is typically injected along with the estradiol at the beginning of the protocol (Martínez et al., 2005, Martínez et al., 2007). A second injection of estradiol can also be administered after CIDR removal to synchronize ovulation which is beneficial in fixed-time AI and fixed-time ET. Administering estradiol 24 h after CIDR removal has been reported as the optimal time to prevent early ovulations, and to allow the dominant follicle time to reach an adequate size to ensure fertility (Martínez et al., 2007).

Estrous Cycles: *Bos indicus* and *Bos taurus* Cattle

Many differences in the estrous cycles between *Bos indicus* and *Bos taurus* cattle have been reported, while some more recent studies have shown them to be more similar than originally thought. The number of small follicles present at the beginning of a follicular wave has been reported to be higher in Brahman cows (39 ± 4) when compared to Angus cows (21 ± 4), and a higher number of medium and large follicles was also observed in Brahman cows when compared to Angus cows (Alvarez et al., 2000). The duration of standing estrus has been reported to be shorter in Nelore cows (12.9 h) and Nelore X Angus crosses (12.4 h) when compared to Angus cows (16.3 h), but the timing of ovulation from the onset of estrus has recently been reported to not differ significantly from *Bos taurus* and *Bos indicus* breeds (reviewed by Bó et al., 2003). Previous studies have reported that the interval from the onset of estrus to ovulation was shorter in Brahman females compared to their *Bos taurus* (Hereford) counterparts, but the interval from the preovulatory LH surge to ovulation did differ significantly among Brahman and Hereford females (reviewed by Randel, 1994). Bo et al. (2003) suggest the use of Heat-Watch™ for estrus detection, and ultrasonography, could explain why recent findings on the interval from the onset of estrus to ovulation differ from previous findings. The maximum diameter of the dominant follicle and the CL appears to be smaller in *Bos indicus* females than *Bos taurus* females (reviewed by Bó et al., 2003, Sartori and Barros, 2011). In a study conducted by Alvarez et al. (2000), the CL diameter was reported to be 10% greater in Brahman cows than in Angus cows. The effect of heat stress on the Angus cows due to season and climate may have contributed to this

inconsistency, since the experiment was conducted during the summer (July-August) in Florida. The growth rate of the dominant follicle between *Bos indicus* cows and *Bos taurus* cows are inversely related and related to season. *Bos indicus* cows have a slower dominant follicle growth rate in the fall (1.1 mm/day) compared to the spring (1.5 mm/day), and *Bos taurus* cows show a faster dominant follicle growth rate in the fall (1.6 mm/day) than in the spring (1.4 mm/day) (Bó et al., 2003). Many of the same synchronization protocols are used between *Bos indicus* and *Bos taurus* females with success, despite the differences in the duration of standing estrus and follicular growth rate.

Equine Chorionic Gonadotropin

The hormone, equine chorionic gonadotropin (eCG), is produced in pregnant mares by the endometrial cups that are present on the embryonic girdle (Hoppen, 1994). The placental gonadotropin consists of an α -subunit (96 amino acids) and a β -subunit (149 amino acids); the β -subunit of eCG is identical to the β -subunit of the equine LH (reviewed by Murphy and Martinuk, 1991). The secretion of eCG reaches its peak between day 60 and day 80 of pregnancy (Hoppen, 1994). The β -subunit of eCG determines the LH and FSH activity, and also the level of FSH activity that this hormone produces in cattle (Chopineau et al., 1997). In mammals other than the horse, eCG binds to both FSH and LH receptors and produces biological responses similar to both of those hormones (reviewed by Murphy and Martinuk, 1991). The β -subunit of eCG must be associated with the equine α -subunit to possess the FSH and LH activities (Chopineau et

al., 1997). Equine CG has a long half-life which can be attributed to its heavy glycosylation and sialic acid linkages (reviewed by Murphy and Martinuk, 1991). A biphasic model of eCG clearance has been suggested in cattle; with the first phase (45.6 h half-life) consisting of the rapid removal from circulation, and the second phase (121 h half-life) consisting of the metabolism and excretion of eCG from the extravascular compartments (reviewed by Murphy and Martinuk, 1991).

An increase in StAR (steroidogenic acute regulatory protein) mRNA levels was found in heifers that were treated with eCG compared to StAR mRNA levels found in heifers treated with FSH (Soumano and Price, 1997). This increase in StAR mRNA was observed in medium and large follicles during the follicular phase of the stimulated estrous cycle (Soumano and Price, 1997). StAR mRNA levels correlate with the active StAR protein (Clark, 1995), so increased mRNA levels should indicate increased StAR protein production. It has been suggested that StAR protein is the rate limiting step in steroidogenesis because it is the protein responsible for transporting cholesterol into the mitochondria where it is then converted into pregnenolone, the precursor for progesterone (Stocco, 1997). Therefore, increased StAR protein should result in increased steroidogenesis, including the production of estradiol and progesterone. The increase in StAR protein seen in eCG-treated animals could help to explain the increased follicular progesterone and estradiol secretion that has been found in eCG-treated animals when compared to FSH-treated animals (Soumano and Price, 1997).

Use of eCG in Protocols for Estrus Synchronization

Many protocols are used to synchronize estrus and the timing of ovulation in recipient cows with the intention of preparing the uterus to receive an embryo. Fixed-time AI/ET protocols work well for this purpose, since estrus detection ability among farms is variable. *Bos indicus* cattle reportedly have a smaller diameter of the dominant follicle and the CL, and also less progesterone content in their CL (Bó et al., 2003), which is why eCG (because of its long-lasting FSH and LH properties) has been added to many synchronization protocols involving *Bos indicus* influenced breeds. It has been shown the addition of 400 IU of eCG at the time of progesterone releasing intravaginal device (PRID) removal along with progesterone/estradiol treatment at the time the PRID is inserted, can increase the pregnancy rates of *Bos indicus* heifers when fixed timed artificial insemination (FTAI) is performed (Bó et al., 2003). An increase pregnancy rate, from eCG administration, was also more evident when cows had small follicles instead of a CL or medium to large follicles at the beginning of synchronization (Bó et al., 2003). Another study using FTAI in beef cows showed that the addition of eCG improved the pregnancy rate of primiparous but not multiparous cows, and that eCG may be more beneficial in cows with lower body condition scores (Small et al., 2009). In a FTAI comparison between FSH and eCG administration on the day of PRID removal, eCG was found to increase ovulation rate (95.5%) and pregnancy rate (66.7%) significantly in lower BCS anestrous cows while the FSH-treated cows received no benefit in ovulation rate (56.4%) and pregnancy rate (25.5%) compared to controls (Sales et al., 2011). There was also a significant increase in follicular growth in the

eCG-treated group (1.4 mm/day) when compared to the FSH (0.90 mm/day) and control group (0.95 mm/day). Sales et al. (2011) suggested the higher follicular growth rate seen in the eCG-treated cows can be explained by the higher LH activity of eCG compared to purified FSH, and the increased follicular growth rate may have led to the higher ovulation rate in cows treated with eCG.

Although the fertility of the oocyte that is ovulated is not a major concern in recipient cows, the resulting CL is. Previous studies using eCG when compared to FSH showed an increase in progesterone concentrations (Chagas e Silva et al., 2002), indicating a luteotrophic effect of eCG which may improve pregnancy rate in recipients as well. Several studies in *Bos indicus*-influenced recipient cows have shown several factors that correlate with pregnancy rate, including plasma progesterone concentration and CL diameter and number. Plasma progesterone concentration was observed to positively correlate with CL size and number in *Bos indicus*-influenced recipients, and as a result a higher pregnancy rate (reviewed by Baruselli et al., 2010). Although, the above correlation was not seen in *Bos taurus* recipient cows, it was found that pregnancy rate in *Bos indicus* recipients was significantly higher in recipient cows that had a plasma progesterone concentration greater than 3 ng mL^{-1} when compared to the pregnancy rate of recipient cows with a non-functional CL and a plasma progesterone concentration less than 1 ng mL^{-1} (reviewed by Baruselli et al., 2010). Area of the CL was positively correlated with plasma progesterone concentration, and pregnancy rate was higher for heifers with a CL area larger than 2 cm^2 compared to a CL area smaller than 1.5 cm^2 (reviewed by Baruselli et al., 2010). Contradictory results from another

study reported no correlation between plasma progesterone concentration and pregnancy/conception rates in *Bos taurus* X *Bos indicus* recipients (Siqueira et al., 2009). Siqueira et al. (2009) also reported no correlation between CL area and pregnancy rate in recipients.

Many studies were conducted to investigate the effect of the dose of eCG administered, and the day of eCG administration (reviewed by Baruselli et al., 2010). Increasing doses of eCG (400, 500, and 600 IU) did not affect pregnancy rate; therefore, 400 IU of eCG was determined to be the optimal dose, since increasing the dose resulted in no added benefit. The day of eCG administration (day 5 and day 8) did affect pregnancy rate. The administration of 400 IU of eCG on d 5 (progesterone releasing device insertion on d 0) was shown to increase CL area and plasma progesterone concentration during the luteal phase (reviewed by Baruselli et al., 2010). The increase in CL area could be a result of increased size of the dominant follicle at luteinization from the gonadotropic effect of eCG, and the increased progesterone concentration during the luteal phase could be a result of the long-lasting LH activity of eCG. As a result, pregnancy rate increased in *Bos indicus*-influenced recipients. This is in agreement with a previous study in which administration of 400 IU of eCG to *Bos indicus* X *Bos taurus* recipients on day 5 resulted in a higher number of CL's, higher plasma progesterone concentration, and higher pregnancy rate when compared to administration of eCG on day 8 (Nasser et al., 2004). Nasser et al. (2004) noted that eCG administered on day 5 would stimulate multiple follicles, since the follicular wave is at an early stage of dominance, while administration on day 8 may only just stimulate

the dominant follicle. The use of eCG is the most effective when used in *Bos indicus*-influenced recipients, recipients that are primiparous, or recipients that are under nutritional stress.

CHAPTER II

SUPEROVULATION OF BEEF COWS WITH FOLLTROPIN[®] AND PLUSET[®]

Introduction

Folltropin[®] is a common porcine pituitary derived FSH preparation used in the superovulation of donor cows, but other FSH preparations can be used as well. Pluset[®] is one of these porcine pituitary derived preparations, having a 1:1 FSH:LH ratio (Kelly et al., 1995). The ratio of FSH:LH for Folltropin[®], determined by radioreceptor assay, is 49:1 (Henderson et al., 1990). An increased LH content in FSH preparations has been found to be detrimental to embryo production, resulting in a decreased percentage of transferrable embryos (reviewed by Mapletoft et al., 2002). Others have observed that stimulated cattle show an increase in the proportion of oocytes that have undergone premature oocyte maturation which they attribute to the LH content in FSH preparations (Hyttel et al., 1991). This observation could explain the decrease in percentage of transferrable embryos that typically occur when FSH preparations containing a higher LH content are used for superstimulation.

A single gonadotropin preparation is typically used during each stimulated cycle in most research conducted on the use of various gonadotropin preparations for the induction of superovulation. There is a paucity of information regarding the use of multiple FSH preparations during a single stimulated cycle in superovulated donors.

In this study, the objective was to compare embryo production between a Folltropin[®] protocol and a Folltropin[®] + Pluset[®] protocol for superovulation of donor

cows. It was hypothesized that the higher LH content in Pluset[®] would not have a detrimental effect on embryo production since it was only administered near the end of the gonadotropin stimulation protocol. The higher LH content in Pluset[®] should improve follicular maturation and improve oocyte quality, therefore, improving embryo yield. Retrospective analysis was conducted on data provided by a private embryo transfer company (OvaGenix, LP, Bryan, TX, USA) to accomplish the objective.

Materials and Methods

The data for this study was obtained from embryo collection records of work performed by a private embryo transfer company, OvaGenix, LP.

The objective of this study was to compare the effects of two different hormone preparations and protocols on embryo production. Each multiparous, Beefmaster donor cow from El Lucero, located in Mexico, was stimulated using both protocols in a switchback arrangement. Each protocol was initiated without regard to the stage of the estrous cycle. The control group (Figure 1) was administered a total of seven Folltropin[®]-V (Bioniche Animal Health, Belleville, Ontario, Canada) injections (im) at 12-h intervals to induce superstimulation. The treatment group (Figure 2) was administered a total of four Folltropin[®]-V injections followed by three Pluset[®] (Minitube of America, Inc., Verona, WI, USA) injections (im). A total of 12 donor cows were included in this study. Six of the donors were stimulated using the Folltropin[®]-V protocol for their first stimulated cycle, and then stimulated using the Folltropin[®]-V + Pluset[®] protocol for their second stimulated cycle.

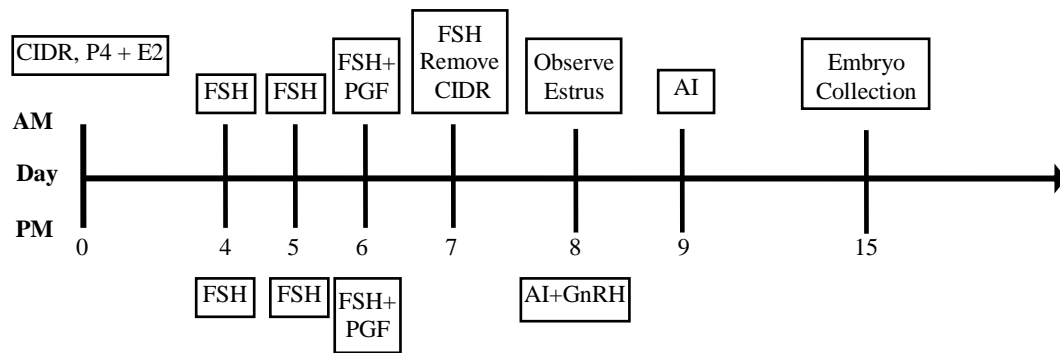

Figure 1. Stimulation protocol for control group (Folltropin[®]).

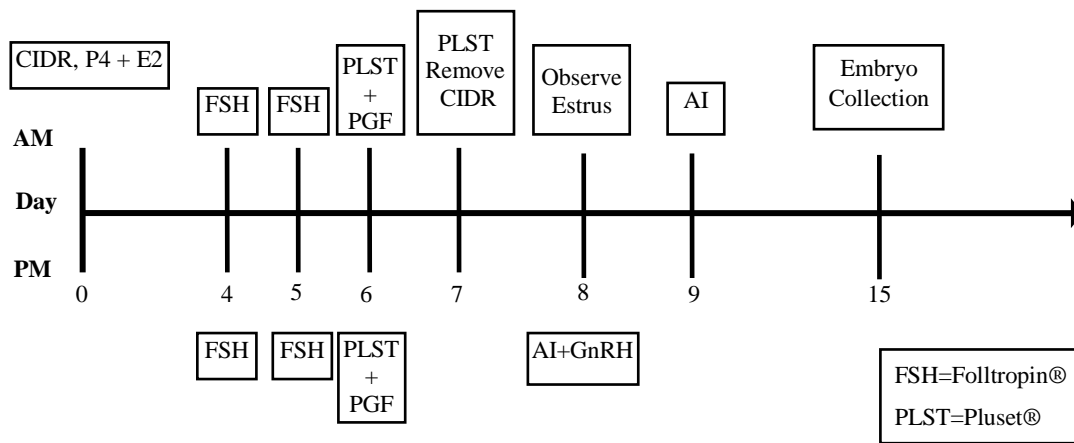

Figure 2. Stimulation protocol for treatment group (Folltropin[®] + Pluset[®]).

The remaining six donors were stimulated with the Folltropin[®]-V + Pluset[®] protocol on their first stimulated cycle, and then they were stimulated using the Folltropin[®]-V protocol for their second stimulated cycle.

Both groups of donors were administered a CIDR[®] (Pfizer Animal Health, Kalamazoo, MI, USA) and an injection (2 mL, im), containing 25 mg/mL of progesterone and 1.25 mg/mL of estradiol (Med Shop Total Care Pharmacy, Inc., Longview, TX, USA), on day 0. FSH injections were administered twice-daily in decreasing dosages beginning on the morning of day 4. The total amount of Folltropin[®]-V administered to donors in the control group ranged from 120 mg to 232 mg NIH-FSH-P1. The total amount of Folltropin[®]-V administered to the donors in the treatment group ranged from 104 mg to 152 mg NIH-FSH-P1. The amount of Pluset[®] administered was the same for all donors. The volume of each consecutive Pluset[®] injection was 1.0 mL, 0.8 mL, and 0.6 mL (im), respectively, for a cumulative dose of 120 IU of FSH and 120 IU of LH. The total amount of FSH product each donor received was determined by the ET practitioner with consideration for age, parity, weight, and previous embryo collection history. Within each donor cow, the amount of FSH administered varied between stimulated cycles. A 2.5 mL injection (im) of Ciclase[®] (Syntex S.A., Buenos Aires, Argentina), a prostaglandin (PGF_{2α}) analogue containing 250 µg/mL of cloprostenol, was administered along with the 5th and 6th FSH injection. The CIDR[®] was removed on day 7 and cows were observed for estrus.

The donors were artificially inseminated (AI) beginning 12 to 16 h after estrus with two units of semen; 20 to 24 h post-estrus with one unit of semen; and 30 to 36 h

post-estrus with one unit if the donor was still in standing estrus at the time of the second insemination. Multiple sires were used. In conjunction with the first AI, GnRH (100 µg, 2 mL Cystorelin[®]; Merial LLC, Duluth, GA, USA) was administered (im).

Embryos were collected between 7 and 7.5 d post-estrus. The donors were collected nonsurgically using an 18 or 20 gauge Foley catheter (Bardia, Covington, GA, USA) which was inserted through the cervix and the balloon cuff was inflated. The Foley catheter was then connect to an EZ way filter with Y junction tubing (PETS, Canton, TX, USA). The media used for embryo collection was Lactated Ringer's (Hospira Inc., Lake Forest, IL) with Bovine Serum Albumin (ICPbio LTD., Auckland, New Zealand). Total ova, viable embryos, unfertilized ova, and degenerate embryos were recorded. The number of viable embryos was determined using IETS embryo grading guidelines, and only embryos that were considered to be grades 1 or 2 were counted as viable embryos.

Treatment and stimulation cycle effects for the total ova, viable embryos, unfertilized ova, degenerate embryos, the proportion of viable embryos to total ova, and the transformed (Arc Sin of the square root) portion of viable embryos to total ova were analyzed by the GLM procedure of SAS 9.2 (SAS; Cary, NC, USA). This study was a Latin square design. Possible sources of variation for this study would include: treatment, cycle, and donor.

Results

The mean number of total ova, viable embryos, degenerate embryos, and unfertilized ova did not differ significantly between the treatment groups (Table 1). The proportion of viable embryos to total ova collected also did not differ significantly between the treatment groups (Table 2). This suggests that the use of Pluset[®] in the superstimulation protocol for donors was neither beneficial nor detrimental to embryo production.

Discussion

The substitution of Pluset[®] for Folltropin[®] in the last three injections of the superovulation protocol was intended to increase embryo production. By administering Pluset[®] towards the end of the superovulation protocol, which has a higher LH content than Folltropin[®], we hypothesized the increased LH content would facilitate follicular growth as the follicles switched from an FSH-dependency to an LH-dependency (Mihm and Bleach, 2003). Also, by only administering Pluset[®] at the end of the protocol we hypothesized the increased LH content would not have a negative effect on the percentage of viable embryos that others have reported (reviewed by Mapletoft et al., 2002). In the present study, there were no significant differences in the mean number of total ova, viable embryos, unfertilized ova, and degenerate embryos between treatment groups. In previous studies, the mean number of total ova collected was significantly higher for females treated with only Pluset[®] compared to mean number of the total ova collected for females treated with only Folltropin[®] (Kelly et al., 1995, Kelly et al., 1997).

Table 1. Mean (\pm SE) number of total ova, viable embryos, degenerate embryos, and unfertilized ova by treatment^a

Treatment	(n)	Total Ova	Viable Embryos	Degenerate Embryos	Unfertilized Ova
Folltropin [®]	12	17.42 \pm 2.40	9.33 \pm 2.07	4.92 \pm 1.37	3.17 \pm 1.11
Folltropin [®] + Pluset [®]	12	12.75 \pm 2.56	6.58 \pm 1.69	4.42 \pm 1.23	1.75 \pm 0.76

^aMeans within a column do not differ ($P > 0.10$).

Table 2. Mean (\pm SE) number of proportion of viable embryos to total ova and the transformed proportion by treatment^a

Treatment	(n)	Viable/Total Ova	Transformed Proportion
Folltropin [®]	12	0.49 \pm 0.10	0.76 \pm 0.13
Folltropin [®] + Pluset [®]	12	0.48 \pm 0.08	0.82 \pm 0.09

^aMeans within a column do not differ ($P > 0.10$).

More importantly, there was not a significant difference in the proportion of viable embryos to total ova between the Folltropin[®] (0.49) and Folltropin[®] + Pluset[®] (0.48) treatment groups and may be attributed to administering the Pluset[®] at the end of the stimulatory protocol. Studies that used Pluset[®] throughout the entire stimulation protocol reported a decrease in the percentage of viable embryos. A study with crossbred beef heifers compared an eight injection Folltropin[®] protocol and a ten injection Pluset[®] protocol and reported a higher number of ovulations for the Pluset[®] group, but a lower proportion of viable embryos to total ova (Kelly et al., 1997). The aforementioned study only used a prostaglandin F_{2α} analogue (Estrumate) to synchronize estrus and during the superstimulation protocol (prostaglandin is not the preferred treatment for synchronizing follicular waves); unlike the present study which included steroids (E2 and P4) to synchronize follicular waves during the superstimulation protocol. It appears that using Pluset[®] for the last three injections in the present study did not have any detrimental effects on embryo production. Since no significant difference between treatment groups was observed for the percentage of viable embryos in this study, we infer that the incidence of premature oocyte maturation or early ovulation, reported in other studies (Dieleman et al., 1983, Kruip et al., 1983, Hyttel et al., 1991), was not sufficient to cause an increase in unfertilized ova or a decrease in the percentage of viable embryos.

In this study, a minimum interval of 60 d occurred between stimulated cycles. Differences in embryo production were observed due to stimulated cycle between donors (first or second stimulated cycle). Previous studies have reported conflicting

results on ovarian responsiveness after repeated superovulatory cycles. Some have indicated a decrease in response after repeated superovulation, while others have reported no difference in response between repeated stimulated cycles (reviewed by Kafi and McGowan, 1997). In a study with records from a commercial embryo transfer company, a decrease in the number of transferable embryos was observed when donor cows were stimulated for multiple cycles (Donaldson and Perry, 1983). The authors attribute this decline in embryo production to depletion in the pool of primary follicles due to repeated superovulation, or a possible immune response to the FSH-P. Another study using virgin heifers also reported a decrease in embryo production after repeated superovulation (Dorn et al., 1991). In an older study, no difference in the number of transferable embryos was observed when donors were superovulated three times with at least 60 days between stimulated cycles (Nelson et al., 1979).

The results of this study indicate that Pluset[®] (with a higher LH content compared to Folltropin[®]) can be administered at the end of the gonadotropin stimulation in a superovulation protocol and not be detrimental to embryo production. The use of Pluset[®] at the end of the protocol did not increase unfertilized ova or decrease the proportion of viable embryos/total ova as has been reported in prior studies where Pluset[®] was used as the only gonadotropin for the superovulation protocol. However, there was no significant difference between treatment groups in this study; therefore, endogenous levels of LH during the stimulated cycle may be sufficient to maintain follicular growth after dominant follicles switch to LH-dependency as reported in prior

studies using recombinant FSH (Looney et al., 1988) and FSH preparations with varying amounts of LH (Mapletoft et al., 2002).

Implications

The administration of Pluset[®] in lieu of Folltropin[®] for the last three injections in a superovulation protocol was not detrimental to embryo production in Beefmaster cows. There was no significant difference between treatment groups on total ova, viable embryos, unfertilized ova, degenerate embryos, or the proportion of viable embryos/total ova. These results indicate further research could be conducted using a protocol similar to this one to determine if embryo production could be increased when compared to a Folltropin[®]-only protocol. Perhaps with the use of varying the doses of Pluset[®], a dose-dependent effect on embryo production could be detected, and an optimal dose of Pluset[®] could be determined. Only one cumulative dose of 120 IU of FSH and 120 IU of LH was used in this study. Also, research comparing the administration of four injections of Pluset[®] instead of the three injections in this protocol may detect a difference on embryo production between treatment groups. The results from this study and possible future research could indicate another stimulation protocol that could be used successfully to stimulate donor cows and increase embryo production. This could be important to the commercial ET industry because it would give practitioners another option to stimulate donors. Especially for those practitioners who deal mostly with *Bos indicus*-influenced breeds.

CHAPTER III

ESTRUS SYNCHRONIZATION OF BEEF COW RECIPIENTS USING eCG

Introduction

Most costs associated with embryo transfer relate to the maintenance of recipient females. Increasing pregnancy rates after embryo transfer will ultimately decrease the number of days recipients are open during the breeding season, and will also help to reduce the costs incurred to maintain open recipients. A more cost effective recipient program could be implemented by reducing recipient-associated costs.

Administration of eCG has been shown to increase CL area and plasma progesterone concentrations during the luteal phase in cattle (reviewed by Baruselli et al., 2010). Baruselli et al. (2010) also indicate that conception rates were higher in *Bos indicus* cows with higher plasma progesterone levels when compared to cows with lower plasma progesterone levels. Pregnancy rates are improved in cows with lower body condition scores that are administered eCG during estrus synchronization and submitted to FTAI (Small et al., 2009).

The objective of this study was to evaluate the effect the addition of eCG to an estrus synchronization protocol would have on pregnancy rates after embryo transfer in recipients. It was hypothesized that pregnancy rate would increase for recipients that were administered eCG. This study was conducted using data obtained from a private embryo transfer company (OvaGenix, LP, Bryan, TX, USA). Due to the conditions of

the study, only pregnancy rates and mean number of corpora lutea were reported and no statistical analysis was conducted.

Materials and Methods

The data from this study was obtained from embryo collection records of work performed by a private embryo transfer company, OvaGenix, LP.

The objective of this study was to quantify the effect of addition of eCG to a synchronization protocol on pregnancy rate in recipient beef cows. Both the control/no eCG (Figure 3) and treatment/eCG groups of multiparous Beefmaster cows were synchronized with a common estrus synchronization protocol. Both groups of recipients were administered a CIDR[®] (Pfizer Animal Health, Kalamazoo, MI, USA) and an injection (2 mL, im), containing 25 mg/mL of progesterone and 1.25 mg/mL of estradiol (Med Shop Total Care Pharmacy, Inc., Longview, TX, USA), on day 0. On day 7, the CIDR[®] was removed, and a 2 mL intramuscular injection of Ciclase[®] (Syntex S.A., Buenos Aires, Argentina), a prostaglandin (PGF_{2α}) analogue containing 250 µg/mL of cloprostenol, was administered. An injection (1 mL, im) of estradiol-17β (1 mg/mL estradiol-17β; Med Shop Total Care Pharmacy, Inc., Longview, TX, USA) was administered on day 8. The treatment group (Figure 4) was administered 400 IU of eCG (Folligon[®]; Intervet Canada Corp., Kirkland, Quebec, Canada; or Novormon 5000; Syntex S.A., Buenos Aires, Argentina) on day 5 (CIDR insertion=day 0), and the control group did not receive an injection of eCG.

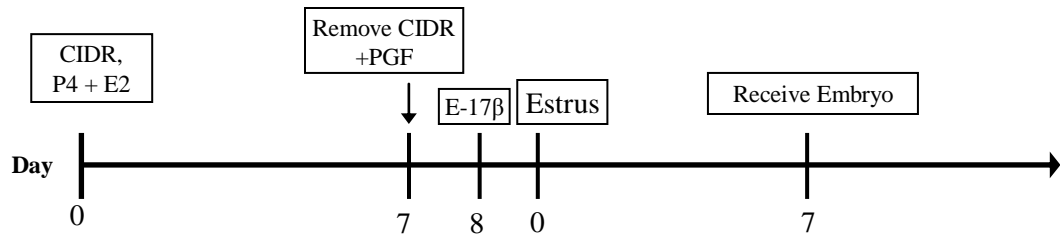

Figure 3. Synchronization protocol without eCG.

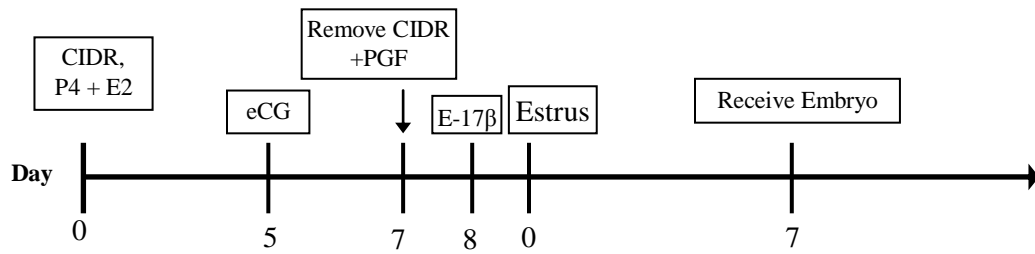

Figure 4. Synchronization protocol with eCG.

Seven days after estrus, if the recipient had an acceptable corpus luteum, an embryo (frozen-direct transfer method) was transferred into the uterine horn ipsilateral to the CL. A CL was deemed acceptable for embryo transfer if it was at least 10 mm in diameter (Looney et al., 2006). The embryos for ET company, C, were cryopreserved using the direct transfer method described by Pryor et al. (2011). Embryos were equilibrated in 1.5 M ethylene glycol (Vigro Freeze medium without sucrose, Bioniche) for a minimum of five minutes, loaded into 0.25 mL sterile straws, and seeded at -6°C in the cryochamber. Each loaded straw consisted of three media columns and two air columns with one embryo in the middle media column. The embryos were frozen using a freeze control CL5500 unit (Biogenics, Napa, CA, USA) at the rate of $-5^{\circ}\text{C}/\text{min}$ from -6°C to -32°C . Once -32°C was reached, the straws were then plunged into LN_2 and placed into canes for storage in LN_2 tanks. The frozen-direct transfer embryos were thawed for 5-7 seconds at room temperature and then immersed in a 30°C water bath for 10 seconds. Once thawed, the straw was dried off, the plug removed, and was loaded into a chemise covered blue metal tip sheath which then covered the $\frac{1}{4}$ cc Cassou gun. The embryo was then transferred nonsurgically into the recipient. The Cassou gun was inserted through the vagina of a recipient with an acceptable CL, and then passed through the cervix into the uterine body while the cervix was manipulated rectally to allow the passage of the gun through the cervical rings. The gun was then advanced forward past the uterine bifurcation and into uterine horn ipsilateral to the CL where the embryo was then expelled.

Data collected for each transfer included the following: treatment (control or eCG), embryo breed, embryo stage and grade, number and location of CL(s), embryo transfer company responsible for freezing the direct-transfer embryo, and the resulting pregnancy status. Pregnancy rate was reported for both the no eCG and eCG groups, ET company responsible for freezing the embryo, embryo stage, embryo grade, and total CL number. Statistical analysis could not be performed because both groups were not synchronized for the same transfer date, and the study was conducted over three years with a one year lapse occurring between both groups.

Results

Pregnancy rate following transfer of Beefmaster frozen embryos between recipients that received eCG and recipients that did not receive eCG is reported in Table 3. Pregnancy rate by embryo transfer company responsible for freezing the direct transfer embryo is also reported in Table 3, along with the pregnancy rate for various embryo stages and grades, and CL numbers. The mean number of corpora lutea for each treatment group can be found in Table 4. The number of corpora lutea (CL) per recipient for both treatment groups ranged from one to two corpora lutea.

Table 3. Pregnancy rate reported for treatment, ET company responsible for freezing embryo, embryo stage, embryo grade, and total CL number

	No. of Transfers	No. Pregnant	Percent Pregnant
<i>Treatment</i>			
No eCG	332	149	44.9
eCG	142	55	38.7
<i>ET company responsible for freezing embryo</i>			
A	201	100	49.8
B	84	45	53.6
C	189	59	31.2
<i>Embryo stage</i>			
4-compact morula	123	43	35.0
5-early blastocyst	114	50	43.9
6-blastocyst	26	6	23.1
<i>Embryo grade</i>			
1	188	66	35.1
2	82	37	45.1
<i>Total CL number</i>			
1	464	202	43.5
2	10	2	20.0

Table 4. Mean total number of corpora lutea for recipients that did not receive eCG and recipients that did receive eCG

Treatment	(n)	CL number	Min CL	Max CL
No eCG	332	1.003	1.00	2.00
eCG	142	1.063	1.00	2.00

Discussion

The addition of eCG to the recipient synchronization protocol was intended to increase pregnancy rate. Published studies have shown an increase in pregnancy rate with the addition of eCG to the synchronization protocol (Nasser et al., 2004, Small et al., 2009, Baruselli et al., 2010). In these studies, eCG benefitted pregnancy rate the most in *Bos indicus* influenced recipients and recipients with lower body condition scores.

Overall the addition of eCG to the synchronization protocol resulted in a lower pregnancy rate compared to the pregnancy rate of the synchronization protocol without eCG; however, under the conditions of this study these pregnancy rates cannot be statistically compared to each other. Other factors that can affect pregnancy rate such as nutrition and weather conditions were not accounted for in this study. Since each of the transfer dates did not have groups of recipients that were synchronized with and without eCG, these factors could have had an effect on pregnancy rate.

Various pregnancy rates were observed among the different ET companies responsible for freezing the direct transfer embryos. Benyei et al. (2006) reported a significant difference in pregnancy rate among ET companies used in their experiment, and they attribute this difference to the subjective embryo evaluation among the staff of the ET companies. The majority of embryos, in the present study, that were transferred on each of the transfer dates came from a single company, meaning a mixture of direct transfer frozen embryos from all three companies were not transferred on the same date. The variance in pregnancy rates between the ET companies could be a result of the time

of the year the embryos were transferred, or the embryo stage and grade of the embryos transferred. The recipients would have been under different weather conditions, and possibly different nutrition, depending on the time of year the embryos were transferred, leading to differences in pregnancy rates regardless of the ET company responsible for freezing those embryos. In Brazil, a higher pregnancy rate was reported for embryos transferred during the wet season than for embryos transferred during the dry season (Benyei et al., 2006). The authors associate the difference in pregnancy rate between seasons with the better nutrition that was available to the recipients during the wet seasons. Differences in the media used between the different ET companies and freezing protocols could also be a source of variation, and this could explain the variances observed in pregnancy rates between the companies. The cryoprotectant used for freezing direct transfer embryos is 1.5 M ethylene glycol. Bovine embryos have a higher degree of permeability to ethylene glycol than glycerol (Voelkel and Hu, 1992). The authors report embryos exposed to ethylene glycol show less volume shrinkage (which can be detrimental to the embryo) than embryos exposed to glycerol, and embryos exposed to ethylene glycol return to their original volume more quickly than the embryos exposed to glycerol. Voelkel and Hu (1992) observed no difference in pregnancy rates between embryos frozen in ethylene glycol and embryos frozen in glycerol. The authors contend the increased permeability bovine embryos have to ethylene glycol allows for the direct rehydration of the embryos in the uterus after transfer; unlike embryos frozen in glycerol, in which the embryos are rehydrated step-

wise using solutions with decreasing concentrations of glycerol or non-permeable osmotic buffers like sucrose.

In the present study, various pregnancy rates were observed among embryo stages and between grades. A study, using Angus recipients, did not report any significant differences in pregnancy rates among embryo stages 4, 5, and 6 (Spell et al., 2001). However, other studies (Martinez et al., 2002, Dochi et al., 1998) have reported higher pregnancy rates for compact morula and early blastocyst stages compared to pregnancy rates for blastocyst stage direct transfer embryos. The authors suggest the lower pregnancy rate observed for blastocysts could be attributed to the increased water content found in the blastocoel cavity which may increase the chance of ice crystal formation (which can damage the embryo) during the freezing process. Another study (Dochi et al., 1995) reported lower pregnancy rates for morula direct transfer embryos when compared to blastocysts, but a low number of embryos were transferred in this study. In a retrospective study with embryos frozen in glycerol, higher pregnancy rates were correlated with higher embryo quality grades (Hasler, 2001). However, another study reported no differences in pregnancy rates among embryo quality grades 1 and 2 of glycerol frozen embryos (Spell et al., 2001). In the present study the pregnancy rate for grade 1 embryos was numerically 10% lower than the pregnancy rate for grade 2 embryos; however, due to the limitations of this study these pregnancy rates cannot be statistically compared to each other.

An increase in the number of corpora lutea would be expected for the group of recipients that were administered eCG as part of their synchronization protocol. In this

study, the reported mean number of corpora lutea was slightly higher for the eCG-treated group of recipients, but no statistical analysis comparing the treatment groups was performed. A previous study using eCG reported a mean CL number of 1.37 for a group of recipients synchronized using the same protocol used in this study (Nasser et al., 2004). Since, the mean number of CL's for this study was lower than the mean number of CL's reported in the Nasser et al. (2004) study, it might help to explain why no improvement in pregnancy rates was found for the eCG treated recipients in this study. Only 10 recipients had 2 CL's in this study, 1 recipient in the group not treated with eCG and 9 recipients in the group treated with eCG. The pregnancy rate was lower for recipients with 2 CL's, but under the conditions of this study the pregnancy rate between the two groups (1 CL or 2 CL) cannot be compared.

The results for this study do not indicate the addition of eCG to a synchronization protocol for embryo transfer to be beneficial; however, a controlled study is warranted to further investigate the potential effect of eCG on pregnancy rate in recipients.

Implications

The addition of eCG to the synchronization protocol for recipients for embryo transfer did not increase pregnancy rate overall. However, in this study recipients were only synchronized with one protocol for each set (date) of transfers, instead of synchronizing recipients with each protocol for each set of transfers. This is why no statistical analysis was performed on the data for this study. Weather conditions and nutrition have been reported to affect pregnancy rate in *Bos-indicus* influenced females

(Randel, 1994, Benyei et al., 2006). Since recipients were not synchronized as a group with the addition of eCG and a group without eCG during each set of transfers, these effects cannot be ruled out. Future research using both protocols concurrently for multiple sets of transfers would allow for valid conclusions to be made. Also, analyzing body condition score (BCS) compared to pregnancy rate for the treatment groups (eCG and no eCG) would be important since previous data indicate eCG is beneficial to pregnancy rate in lower BCS females (Small et al., 2009, Sales et al., 2011). Observing the number of recipients that are rejected, due to an inadequate CL or absence of a CL, for each protocol would also be beneficial. If a fewer number, or percentage, of recipients were found to be rejected for recipients treated with eCG this could indicate a benefit for the use of eCG; even if the pregnancy rates did not differ between recipients who received eCG and recipients that did not receive eCG. Rejecting fewer recipients would result in more embryos transferred and more pregnancies, even if pregnancy rate did not differ.

CHAPTER IV

CONCLUSIONS

The results from the first retrospective study indicate that Pluset[®] can be used as the last three gonadotropin injections during a stimulation protocol to superovulate Beefmaster donor cows without having a significant effect on embryo production when compared to a stimulation protocol using only Folltropin[®]. Although the mean number of viable embryos tended to be lower for donors who received Pluset[®] when compared to donors who received only Folltropin[®], this difference was not significant. More importantly, the proportion of viable embryos to total ova was approximately equal for the stimulation protocol using only Folltropin[®] and the stimulation protocol using both Folltropin[®] and Pluset[®]. These results differ from other studies which report a decrease in the proportion of viable embryos to total ova typically observed when gonadotropin preparations containing a higher LH content are used as the sole hormone preparation during the stimulation protocol. Further research using more than one hormone preparation during the stimulation protocol to improve embryo production is warranted.

The results from the second retrospective study do not indicate that the addition of eCG to an estrus synchronization protocol for beef recipients in an embryo transfer program is beneficial. However, a control group and treatment group were not set up for each set of transfers; therefore, other factors such as environmental factors could have masked any effects that the addition of eCG could have had. More research is warranted in this case, so a control group and treatment group of recipients can be set up for the

same set of transfers. It would also be beneficial to record the number of recipients that were synchronized but rejected at the time of embryo transfer due to an inadequate CL or absence of a CL. Further research may show that although eCG may not increase pregnancy rate, it may decrease the percentage of recipients rejected which would increase the number of embryos transferred and ultimately result in more pregnancies.

LITERATURE CITED

- Adams, G. P. 1994. Control of ovarian follicular wave dynamics in cattle: Implications for synchronization & superstimulation. *Theriogenology*. 41: 19-24.
- Adams, G. P., L. F. Nasser, G. A. Bo, A. Garcia, M. R. Del Campo, and R. J. Mapletoft. 1994. Superovulatory response of ovarian follicles of Wave 1 versus Wave 2 in heifers. *Theriogenology*. 42: 1103-1113.
- Alvarez, P., L. J. Spicer, C. C. Chase, Jr, M. E. Payton, T. D. Hamilton, R. E. Stewart, A. C. Hammond, T.A. Olson, and R. P. Wettemann. 2000. Ovarian and endocrine characteristics during an estrous cycle in Angus, Brahman, and Senepol cows in a subtropical environment. *J. Anim Sci*. 78: 1291-1302.
- Baruselli, P. S., R. M. Ferreira, M. F. S. Filho, L. F. T. Nasser, C. A. Rodrigues, and G. A. Bó. 2010. Bovine embryo transfer recipient synchronisation and management in tropical environments. *Reproduction, Fertility and Development*. 22: 67-74.
- Benyei, B., I. Komlosi, A. Pecs, G. Pollott, C. H. Marcos, A. D. O. Campos, and M. P. Lemes. 2006. The effect of internal and external factors on bovine embryo transfer results in a tropical environment. *Animal Reproduction Science*. 93: 268-279.
- Bo, G. A., G. P. Adams, R. A. Pierson, and R. J. Mapletoft. 1995. Exogenous control of follicular wave emergence in cattle. *Theriogenology*. 43: 31-40.
- Bo, G. A., P. S. Baruselli, and M. F. Martínez. 2003. Pattern and manipulation of follicular development in *Bos indicus* cattle. *Animal Reproduction Science*. 78: 307-326.
- Bo, G. A., D. C. Guerrero, A. Tribulo, H. Tribulo, R. Tribulo, D. Rogan, and R. J. Mapletoft. 2010. New approaches to superovulation in the cow. *Reproduction, Fertility, and Development*. 22: 106-112.
- Bo, G. A., D. Hockley, H. Tribulo, F. Jofre, R. Tribulo, N. Busso, A. D. Barth, and R. J. Mapletoft. 1991. The effect of dose schedule and route of administration on superovulatory response to Folltropin in the cow. *Theriogenology*. 35: 186-186.
- Bo, G. A., D. K. Hockley, L. F. Nasser, and R. J. Mapletoft. 1994. Superovulatory response to a single subcutaneous injection of Folltropin-V in beef cattle. *Theriogenology*. 42: 963-975.

- Bo, G. A., H. Tribulo, M. Caccia, and R. Tríbulo. 1998. Superovulatory response of beef heifers treated with estradiol benzoate, progesterone and CIDR-B vaginal devices. *Theriogenology*. 49: 375-375.
- Chagas e Silva, J., L. Lopes da Costa, and J. Robalo Silva. 2002. Embryo yield and plasma progesterone profiles in superovulated dairy cows and heifers. *Animal Reproduction Science*. 69: 1-8.
- Chopineau, M., N. Martinat, H. Marichatou, C. Troispoux, C. Auge-Gouillou, F. Stewart, Y. Combarous, and F. Guillou. 1997. Evidence that the alpha-subunit influences the specificity of receptor binding of the equine gonadotrophins. *J Endocrinology*. 155: 241-245.
- Clark, B. J. 1995. Hormonal and developmental regulation of the steroidogenic acute regulatory protein. *Molecular Endocrinology*. 9: 1346-1355.
- Dieleman, S. J., T. A. M. Kruip, P. Fontijne, W. H. R. Dejong, and G. C. Vanderweyden. 1983. Changes in estradiol, progesterone and testosterone concentrations in follicular-fluid and in the micromorphology of preovulatory bovine follicles relative to the peak of luteinizing-hormone. *Journal of Endocrinology*. 97: 31-42.
- Dierschke, D. J., C.L. Chaffin, and R.J. Hutz. 1994. Role and site of estrogen action in follicular atresia. *Trends in Endocrinology and Metabolism*. 5: 215-219.
- Dochi, O., K. Imai, and H. Takakura. 1995. Birth of calves after direct transfer of thawed bovine embryos stored frozen in ethylene glycol. *Animal Reproduction Science*. 38: 179-185.
- Dochi, O., Y. Yamamoto, H. Saga, N. Yoshiba, N. Kano, J. Maeda, K. Miyata, A. Yamauchi, K. Tominaga, Y. Oda, T. Nakashima, and S. Inohae. 1998. Direct transfer of bovine embryos frozen-thawed in the presence of propylene glycol or ethylene glycol under on-farm conditions in an integrated embryo transfer program. *Theriogenology*. 49: 1051-1058.
- Donaldson, L. E. and B. Perry. 1983. Embryo production by repeated superovulation of commercial donor cows. *Theriogenology*. 20: 163-168.
- Dorn, C. G., J. F. Baker, D. K. Lunt, and D. C. Kraemer. 1991. Repeated, short interval superovulation in virgin heifers. *Theriogenology*. 35: 302.
- Hasler, J. F. 2001. Factors affecting frozen and fresh embryo transfer pregnancy rates in cattle. *Theriogenology*. 56: 1401-1415.

- Henderson, K., A. Weaver, R. L. Wards, K. Ball, S. Lun, C. Mullin, and K. P. McNatty. 1990. Oocyte production and ovarian steroid concentrations of immature rats in response to some commercial gonadotrophin preparations. *Reproduction, Fertility and Development*. 2: 671-682.
- Hoppen, H. O. 1994. The equine placenta and equine chorionic-gonadotropin - an overview. *Experimental and Clinical Endocrinology*. 102: 235-243.
- Hyttel, P., H. Callesen, T. Greve, and M. Schmidt. 1991. Oocyte maturation and sperm transport in superovulated cattle. *Theriogenology*. 35: 91-108.
- Kafi, M. and M. R. McGowan. 1997. Factors associated with variation in the superovulatory response of cattle. *Animal Reproduction Science*. 48: 137-157.
- Kanitz, W., F. Becker, F. Schneider, E. Kanitz, C. Leiding, and R. Pohland. 2002. Superovulation in cattle: practical aspects of gonadotropin treatment and insemination. *Reproduction Nutrition Development*. 42: 587-599.
- Kelly, P., P. Duffy, A. Baguisi, J. R. Dobrinsky, E. W. Overstrom, R. T. Duby, J. F. Roche, and M. P. Boland. 1995. Effect of FSH type and number of injections on peripheral FSH concentrations, follicle numbers and embryo yield in heifers. *Theriogenology*. 43: 245.
- Kelly, P., P. Duffy, J. F. Roche, and M. P. Boland. 1997. Superovulation in cattle: effect of FSH type and method of administration on follicular growth, ovulatory response and endocrine patterns. *Animal Reproduction Science*. 46: 1-14.
- Kruip, T. A. M., S. J. Dieleman, T. H. van Beneden, and D. G. Cran. 1983. Structural changes in bovine oocytes during final maturation in vivo. *Gamete Research*. 8: 29-47.
- Looney, C. R., K. R. Bondioli, K. G. Hill, and J. M. Massey. 1988. Superovulation of donor cows with bovine follicle-stimulating hormone (bFSH) produced by recombinant DNA technology. *Theriogenology*. 29: 271.
- Looney, C. R., J. S. Nelson, H. J. Schneider, and D. W. Forrest. 2006. Improving fertility in beef cow recipients. *Theriogenology*. 65: 201-209.
- Lovie, M., A. García, A. Hackett, and R. J. Mapletoft. 1994. The effect of dose schedule and route of administration on superovulatory response to follitropin in holstein cows. *Theriogenology*. 41: 241-241.
- Mapletoft, R. J., M. F. Martinez, G. P. Adams, J. Kastelic, and C. A. Burnley. 1999. The effect of estradiol preparation on follicular wave emergence and superovulatory response in norgestomet-implanted cattle. *Theriogenology*. 51: 411-411.

- Mapletoft, R. J., K. B. Steward, and G. P. Adams. 2002. Recent advances in the superovulation in cattle. *Reproduction Nutrition Development*. 42: 601-611.
- Martinez, A. G., G. M. Brogliatti, A. Valcarcel, and M. A. de las Heras. 2002. Pregnancy rates after transfer of frozen bovine embryos: a field trial. *Theriogenology*. 58: 963-972.
- Martinez, M. F., G. P. Adams, D. R. Bergfelt, J. P. Kastelic, and R. J. Mapletoft. 1999. Effect of LH or GnRH on the dominant follicle of the first follicular wave in beef heifers. *Animal Reproduction Science*. 57: 23-33.
- Martinez, M. F., G. P. Adams, J. P. Kastelic, D. R. Bergfelt, and R. J. Mapletoft. 2000. Induction of follicular wave emergence for estrus synchronization and artificial insemination in heifers. *Theriogenology*. 54: 757-769.
- Martínez, M. F., J. P. Kastelic, G. A. Bó, M. Caccia, and R. J. Mapletoft. 2005. Effects of oestradiol and some of its esters on gonadotrophin release and ovarian follicular dynamics in CIDR-treated beef cattle. *Animal Reproduction Science*. 86: 37-52.
- Martínez, M. F., J. P. Kastelic, M. G. Colazo, and R. J. Mapletoft, R. J. 2007. Effects of estradiol on gonadotrophin release, estrus and ovulation in CIDR-treated beef cattle. *Domestic Animal Endocrinology*. 33: 77-90.
- Mihm, M., P. J. Baker, J. L. H. Ireland, G. W. Smith, P. M. Coussens, A. C. O. Evans, and J. J. Ireland. 2006. Molecular evidence that growth of dominant follicles involves a reduction in follicle-stimulating hormone dependence and an increase in luteinizing hormone dependence in cattle. *Biology of Reproduction*. 74: 1051-1059.
- Mihm, M. and E. C. L. Bleach. 2003. Endocrine regulation of ovarian antral follicle development in cattle. *Animal Reproduction Science*. 78: 217-237.
- Monteiro, F. M., D. S. Melo, M. M. G. Ferreira, L. M. Carvalho, E. S. e Sartoreli, B. G. Ederhardt, G. D. P. Nogueira, and C. M. Barros. 2009. LH surge in Nelore cows (*Bos indicus*), after induced estrus or after ovarian superstimulation. *Animal Reproduction Science*. 110: 128-138.
- Murphy, B. D. and S. D. Martinuk. 1991. Equine chorionic gonadotropin. *Endocr. Rev.* 12: 27-44.
- Nasser, L. F., E. L. Reis, M. A. Oliveira, G. A. Bó, and P. S. Baruselli. 2004. Comparison of four synchronization protocols for fixed-time bovine embryo transfer in *Bos indicus* × *Bos taurus* recipients. *Theriogenology*. 62: 1577-1584.

- Nelson, L. D., G. E. Seidel Jr, R. P. Elsdon, and R. A. Bowen. 1979. Superovulation of cows using follicle stimulating hormone and prostaglandin F2 α . *Theriogenology*. 11: 104.
- Price, C. A., P. D. Carrière, N. Gosselin, H. Kohram, and L. A. Guilbault. 1999. Effects of superovulation on endogenous LH secretion in cattle, and consequences for embryo production. *Theriogenology*. 51: 37-46.
- Pryor, J. H., C. R. Looney, S. Romo, D. C. Kraemer, and C. R. Long. 2011. Cryopreservation of in vitro produced bovine embryos: effects of lipid segregation and post-thaw laser assisted hatching. *Theriogenology*. 75: 24-33.
- Randel, R. D. 1994. Unique reproductive traits of Brahman and Brahman based cows. In: Page 23 in *Factors Affecting Calf Crop*. M. J. Fields and R. S. Sand, eds. CRC Press, Boca Raton, FL.
- Sales, J. N. S., G. A. Crepaldi, R. W. Giroto, A. H. Souza, and P. S. Baruselli. 2011. Fixed-time AI protocols replacing eCG with a single dose of FSH were less effective in stimulating follicular growth, ovulation, and fertility in suckled-anestrus Nelore beef cows. *Animal Reproduction Science*. <<http://www.sciencedirect.com/science/article/B6T43-525GWSC-1/2/3cac34b2cfacee0beea79f21be04b5be>> Accessed March 3, 2011.
- Sartori, R. and C. M. Barros. 2011. Reproductive cycles in *Bos indicus* cattle. *Animal Reproduction Science*. <<http://www.sciencedirect.com/science/article/B6T43-524WF4W-2/2/a29be5e1c90aec1775afc00ada4d62f6>> Accessed March 7, 2011.
- Schallenberger, E., P. Ulrich, E. Möstl, S. Fuchs, and H. Tenhumberg. 1994. Induction of superovulation in cattle comparing single subcutaneous and repeated epidural with standard intramuscular administration of FSH. *Theriogenology*. 41: 290-290.
- Senger, P. L. 2003. *Pathways to Pregnancy and Parturition*. 2nd revised ed. Current Conceptions, Inc., Pullman, WA.
- Simões, R. A. L., R. A. Satrapa, F. S. Rosa, M. Piagentini, A. C. S. Castilho, R. L. Ereno, L. A. Trinca, M. F. G. Nogueira, J. Buratini Jr, and C. M. Barros. 2011. Ovulation rate and its relationship with follicle diameter and gene expression of the LH receptor (LHR) in Nelore cows. *Theriogenology*. <<http://www.sciencedirect.com/science/article/pii/S0093691X11003591>> Accessed September 13, 2011.
- Siqueira, L. G. B., C. A. A. Torres, E. D. Souza, P. L. J. Monteiro Jr, E. K. N. Arashiro, L. S. A. Camargo, C. A. C. Fernandes, and J. H. M. Viana. 2009. Pregnancy rates and corpus luteum-related factors affecting pregnancy establishment in bovine

- recipients synchronized for fixed-time embryo transfer. *Theriogenology*. 72: 949-958.
- Small, J. A., M. G. Colazo, J. P. Kastelic, and R. J. Mapletoft. 2009. Effects of progesterone presynchronization and eCG on pregnancy rates to GnRH-based, timed-AI in beef cattle. *Theriogenology*. 71: 698-706.
- Soumano, K. and C. A. Price. 1997. Ovarian follicular steroidogenic acute regulatory protein, low-density lipoprotein receptor, and cytochrome P450 side-chain cleavage messenger ribonucleic acids in cattle undergoing superovulation. *Biology of Reproduction*. 56: 516-522.
- Spell, A. R., W. E. Beal, L. R. Corah, and G. C. Lamb. 2001. Evaluating recipient and embryo factors that affect pregnancy rates of embryo transfer in beef cattle. *Theriogenology*. 56: 287-297.
- Stocco, D. M. 1997. A StAR search: implications in controlling steroidogenesis. *Biology of Reproduction*. 56: 328-336.
- Voelkel, S. A. and X. Y. Hu. 1992. Direct transfer of frozen-thawed bovine embryos. *Theriogenology*. 37: 23-37.
- Walsh, J. H., R. Mantovani, R. T. Duby, E. W. Overstrom, J. R. Dobrinsky, W. J. Enright, J. F. Roche, and M. P. Boland. 1993. The effects of once or twice daily injections of pFSH on superovulatory response in heifers. *Theriogenology*. 40: 313-321.

VITA

Kelley Christine Chiles
4202 Lexington Pkwy
Colleyville, TX 76034
kcchiles@gmail.com

Education: M.S., Physiology of Reproduction, Texas A&M University, 2012
B.S., Animal Science, Texas A&M University, 2008

Experience:

2008-2010 Graduate Teaching Assistant, Department of Animal Science, Texas
A&M University, College Station, TX.

2008-2011 Lab Assistant, OvaGenix, Bryan, TX.