

PETR HORYL*, RICHARD ŠŇUPÁREK**

REINFORCING MEASURES OF STEEL ROADWAY SUPPORT IN ROCKBURST PRONE AREAS**WZMACNIANIE STALOWYCH OBUDÓW CHODNIKOWYCH W OBSZARACH ZAGROŻONYCH TĄPIŃCIAMI**

Due to the strong impacts of rockbursts in Ostrava-Karvina coalfield, which affect especially roadways and cross-cuts of longwall panels, it is necessary to strengthen standard steel roadways and breakthroughs supports. However it is a little different task in comparison with main solved problems of mining safety (Kidybiński, 2011), the use of reinforcing complementary bolts seems to be very effective. A varieties of numbers and locations of such rockbolts have been analyzed and compared from the viewpoint of the stability under dynamic events on the base of 3D mathematic modeling. The method used for computer modeling has been FEM applied by ANSYS code. It deals with the shape and nature the following issues: the deformation of a steel support, strain and deformation of reinforcing bolts, the critical energy by which a permanent strain is caused and the influential interaction of the adjacent rock on the above mentioned characteristics. A recommendation for number and location of reinforcing complementary bolts is also contained.

Keywords: roadway support, rockburst, bolting

Z uwagi na silne skutki tąpnięć występujących w obszarze zagłębia węglowego Ostrava-Karlina, których skutki najsilniej odczuwane są w rejonie chodników i przecinek konieczne jest wzmocnienie stalowych obudów tunelowych i obudów w przejściach. Jest to jednak drobny problem w porównaniu z głównymi problemami zapewnienia bezpieczeństwa kopalni (Kidybiński, 2011), jako że zastosowanie kotwienia do dodatkowego wzmocnienia obudowy wydaje się zabiegiem skutecznym. Przeanalizowano lokalizację i ilość zastosowanych kotwi. Wyniki porównano z wynikami badań stabilności w warunkach dynamicznych, przeprowadzonych z wykorzystaniem trójwymiarowego modelowania matematycznego. Modelowanie przeprowadzono w oparciu o metodę elementów skończonych, z wykorzystaniem programu ANSYS. W oparciu o metodę określa się kształt i charakter odkształceń obudów stalowych, naprężenia i odkształcenia wzmocnień kotwi, graniczną wartość energii przy której następuje trwałe odkształcenie oraz wzajemne oddziaływania z otaczającymi skałami i ich wpływ na wyżej wymienione charakterystyki. Podano także rekomendacje odnośnie ilości i lokalizacji uzupełniających kotwi.

Słowa kluczowe: obudowa wyrobisk, tąpnięcia, kotwienie

* VSB-TECHNICAL UNIVERSITY OF OSTRAVA, DEPARTMENT OF MECHANICS, 17. LISTOPADU 15, 70833 OSTRAVA, CZECH REPUBLIC, CENTRE OF EXCELLENCE IT4 INNOVATIONS

** INSTITUTE OF GEONICS ASCR, STUDENTSKÁ 1768, 70800 OSTRAVA, CZECH REPUBLIC, INSTITUTE OF CLEAN TECHNOLOGIES FOR MINING AND UTILIZATION OF RAW MATERIALS FOR ENERGY USE

1. Introduction

Hard coal extraction in the Ostrava-Karviná Coalfield (hereafter OKC) ,which is part of the Upper Silesian Coal Basin, is accompanied by rockburst manifestations. The unfavourable impacts of rockbursts on the safety and health of miners as well as on the total coal production economy have necessitated the investigation of the conditions and action of such dynamic events and to adopt effective measures.

A sudden failure of a loaded structural unit of rock mass (usually of rigid interseam strata) can induce such stresses in the rock mass so that a rockburst with release of elastic deformation energy occurs causing conspicuous deformations and devastations to the affected mine workings. (Fig. 1).

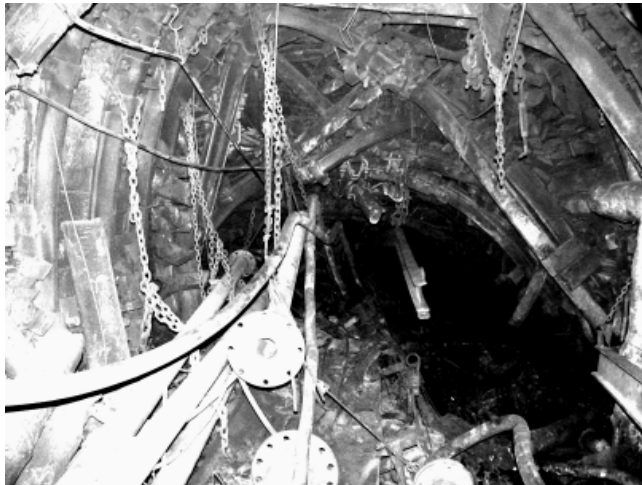

Fig. 1. Roadway after rockburst

From the analysis (Konečný, 2003; Šňupárek & Zeman, 2005), 95% of the rockbursts in last 10 years did not occur in longwall faces but in long mine workings (roadways, break-throughs). The most widely accepted explanation is that the resistance of the support is decisive for the occurrence of underground rockbursts (in view of the damaging of the mine working). In roadways with substantially lower load-bearing support, even weaker energy events appear. From this viewpoint, research into strengthening measures of standard roadway support can bring valuable results (Albrecht & Potvin, 2005).

2. Modeling of the dynamic response of supports

In previous works we dealt with the mathematic modeling of steel roadway supports which including strengthening measures under dynamic loading caused by rockbursts (Horyl & Šňupárek, 2007, 2009).

The aim of the computer modeling was to determine the behavior of a steel support during the dynamic response process as it developed once it was provoked by a rockburst (Stacey & Ortlepp, 2000). It deals primarily with the following:

- the shape and nature of permanent strain or deformation of the steel support
- critical amount of energy by which a permanent strain is caused
- degree of total plastic strain
- the effect of the interaction between a support and adjacent rocks on the above-mentioned characteristics
- comparison of different constructions and reinforcing measures for the roadway support.

The computer modeling used a finite element method – FEM which was applied by ANSYS software. ANSYS pocket software with its possibilities belongs (with NASTRAN, MARC ABAQUS etc) to the best software packets using in engineering and scientific practice. Its merit is solving of intense nonlinear tasks including nonlinear behavior of materials, large deformations and friction contacts. We used for our purposes the Newmark's numerical method with controlled value of time accession.

Theoretically it is possible to create FEM models of roadway support from beam elements, shell elements or of solid volume elements. An optimum solution is the application of shell type elements by which bending is transferred. Because of the work with permanent (plastic) strain it is necessary to adopt the bilinear material properties for steel, as this possibility is offered by the ANSYS program, see Fig. 2.

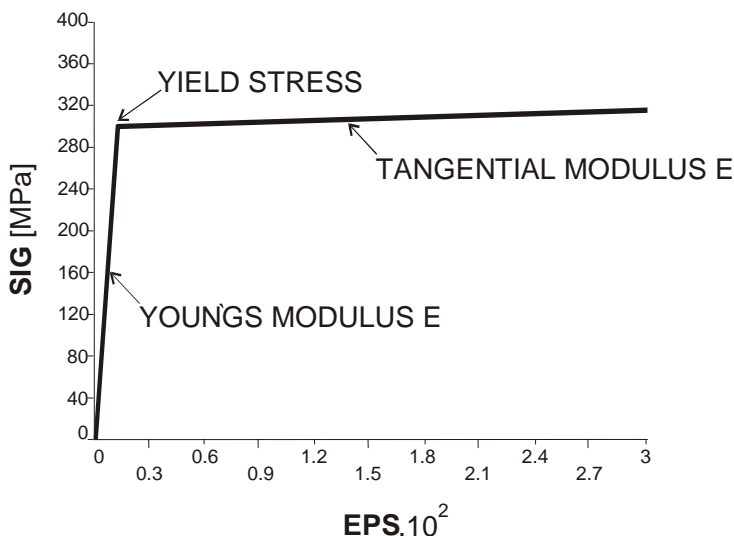

Fig. 2. Bilinear material model

Roadway support

The profile of the support used is a rolled V-type steel section P28 (28 kg/m), very similar to profile V 29. The mechanics of dynamic response of the support types with plastic properties of material and with large displacements and large strains represents a highly non-linear problem. The stiffness matrix of the system is a function of the displacement. A linear damping was considered, proportional to the stiffness matrix $[K]$. The matrix of damping $[D] = \beta [K]$ where the coefficient β can be determined approximately from relative wind-up ξ of the material and the lowest natural frequency Ω_1 according to formula $\beta = 2\xi/\Omega_1$. The equation for movement (it is a differential equation of the second order) is solved numerically by a Newmark implicit „step by step“ method. The discretized system represents a problem with an order of 10 000 degrees of freedom. After the termination of the action of the load, the response should be solved as long as the support loses its kinetic energy and it remains permanently, i.e. plastically strained. In all types of support the transient response will die away during 0.5 s (Fig. 6.). The material used for the support is steel with a Young's modulus $E = 2.1E11$ Pa, yield point $\sigma_y = 280$ MPa, tangential modulus of elasticity $E_T = 1176$ MPa and a ductility of 20%.

Clamp connections

Clamp coupling is realized by the insertion of one profile into another and clamping by means of contracting yokes. The modeling of such a complicated friction clamp coupling represents an enormously difficult task. In the first stage of computing the clamp coupling, without yield, was considered a rigid and non-functional support (stiff support). In next stages a 3D model of the real clamp connection was used (Fig. 3).

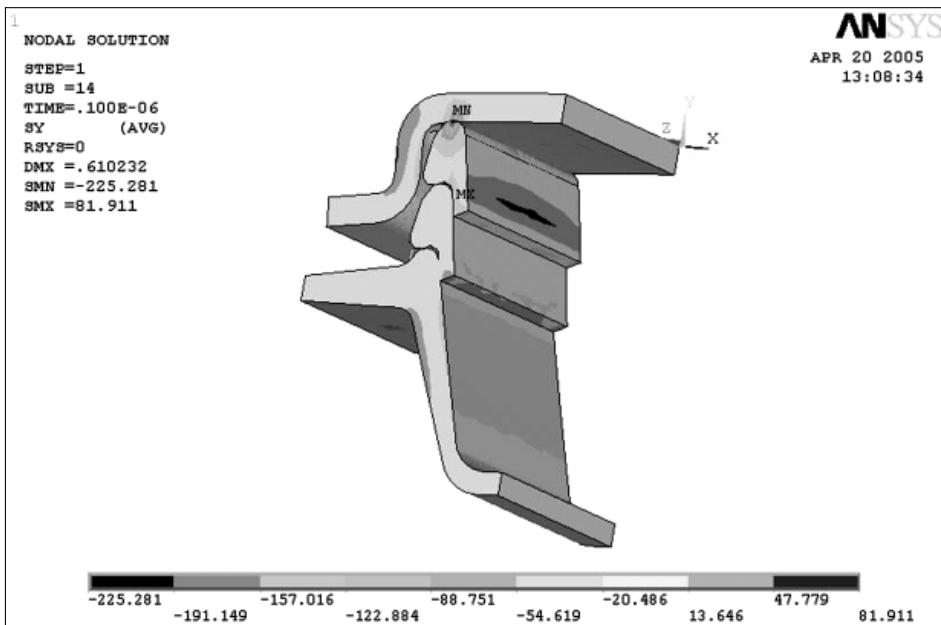

Fig. 3. 3D model of connection

Boundary conditions

The boundary conditions were selected as seen in Fig. 4. It is a plane set where its left end is clamped and its right end is an articulated shifting one (i.e. simply supported). In the second stage, the computer simulations could be more exactly specified by incorporating the influence of the surrounding rock mass. On one hand, the incorporation of the influence of backfill (packing) on its left side (up to the level of the first clamp coupling) was considered and on the other hand a resistance of the floor (against movement of the right hand end of the support) was considered.

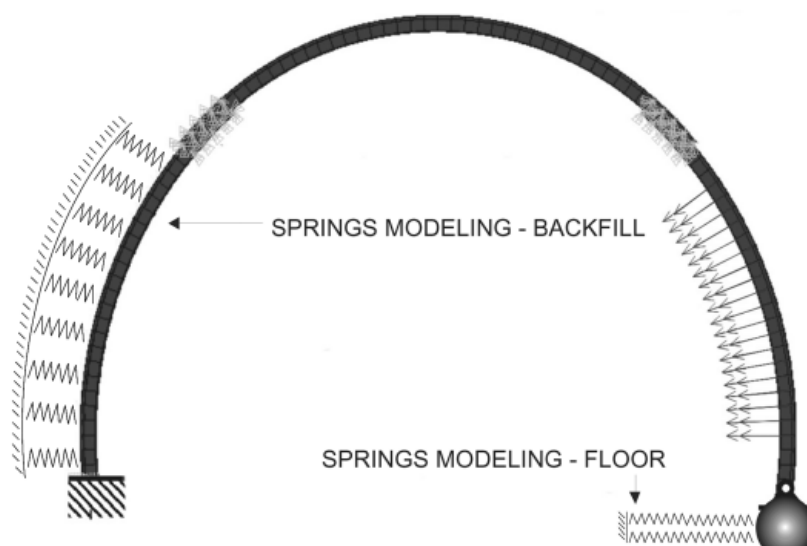

Fig. 4. Boundary conditions with influence of backfill

Both such influences were taken into consideration in the model as non-linear springs. They were considered non-linear in the sense that they transfer pressure only. They did not produce a return movement for the roadway support. Also here the damping value was considered as a small one. We performed the analytical study of the influence of stiffness of the springs on the dynamic response of the support. Modulus of compressibility of backfill was deduced from laboratory tests in the value $8E7 \text{ N} \cdot \text{m}^{-3}$. Surrounding rock mass was considered as absolutely stiff material. On the base of deformation modulus of backfill we determined parameters of substitute springs (Winkler's subsurface). The value of the spring constant for the lining was determined from the mean value of Young's modulus of elasticity, $E_{obl} = 50 \text{ MPa}$. In the case of the floor, a substantially lower modulus value corresponding with floor fill was assumed, i.e. the value $E_{poc} = 0.5 \text{ MPa}$.

Rockburst impact

One of the primary aims of the computer analysis was to determine the value of the initial conditions so that they could act as a marker for plastic strain for the roadway support (McGarr, 1997). The principal applied load was an impulse of force (loading impulse), see Fig. 5. The

force F acts in every one of 130 nodes of modeled side part of the arch. The time course of loading impulse is identical with development of the acting forces. The total loading impulse, I , is equal to the value of integral:

$$I = \int_0^{t_{\max}} F(t) \cdot dt$$

In modeling we used the impulse of force according to the Fig. 5 with the maximum force 1000-2000 N in one node. The resultant value of impulse in this case (with the maximum force 1400 N in one node) is equal approximately to 2 kNs.

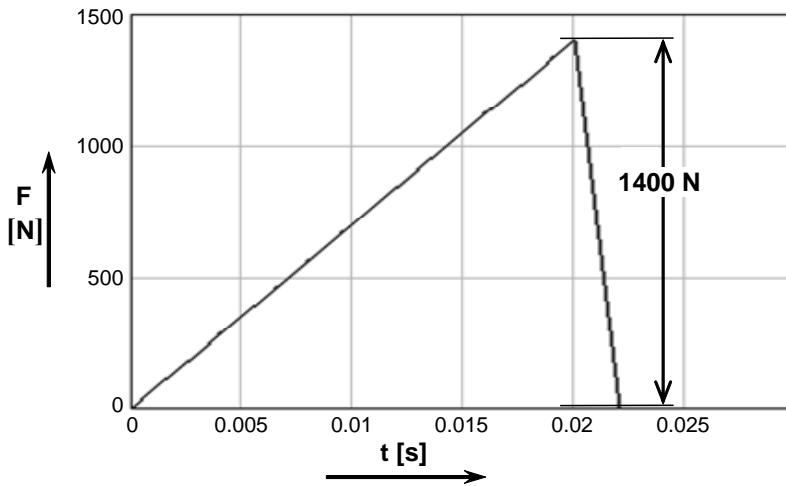

Fig. 5. Course of loading force (impulse of force)

The value of the impulse of force cca 2 kNs to one support frame was deduced from the next promises. Mass of the coal or rock block which hits on one arch support is max. 500 kg (responds to 0,4 m³ of coal) with max. speed 15 m/s (Mc Garr 1997). Linear momentum of the block is $H = m \cdot v = 7.5$ kNs. The part – 25% of linear momentum which corresponds to cca 2 kNs – is transferred to the support during rockburst. As the change of linear momentum is equal to the impulse of force, we set as a testing value the impulse of force $I = 2$ kNs, which answers to the value 1400 N in one node. The lasting time of the impulse of force was deduced from seismic records.

The development of strain energy accumulated in the support was considered to be as important as the indicator of resistance of the support and the effect of reinforcing measures. For detecting strain and kinetic energy in development of the dynamic response, a subprogram (own macro) was created in programming language APDL of the ANSYS program. The energy values are computed according to the next equations:

$$\text{strain energy} \quad \Pi_d = \frac{1}{2} \{\Delta\}^T [K_i] \{\Delta\}$$

$$\text{total energy} \quad \Pi_{tot} = \frac{1}{2} \{\Delta\}^T [K_i] \{\Delta\} + \frac{1}{2} \{\dot{\Delta}\}^T [M_i] \{\dot{\Delta}\}$$

$$\text{friction energy} \quad \Pi_{fric} = \sum_n \{\partial\Delta_i\}^T \{T\}$$

where

- $\{\Delta\}$... — displacement vector e.g. degree of freedom
- $[K_i]$... — stiffness matrix of i -th part of model e.g. bolts, support, screw...
- $\{\dot{\Delta}\}$... — velocity vector
- $[M_i]$... — mass matrix of i -th part of model e.g. bolts, support, screw...
- $\{\partial\Delta_i\}$... — increment of displacement in i -th step of dynamic solution
- $\{T\}$... — vector of friction forces.

A friction energy lost by friction in yielding connections is computed in different own sub-program created in programming language APDL. It is based on computing of work of friction forces in ever contact node in ever computing step. The final friction energy is the sum of all steps during a full modeled dynamic action.

A typical development of energies during a dynamic process can be seen in the Fig. 6, where the final form of plastic strain in the roadway support is depicted.

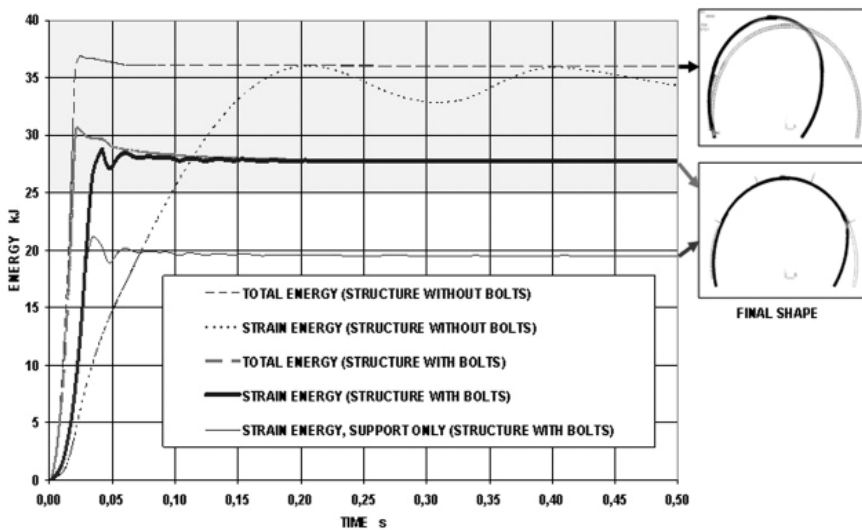

Fig. 6. Course of energies

3. Model of roadway support

The modeled strengthening measure was the anchoring of the arch support to the surrounding rock with bolts. Firstly we modeled an anchored support with 4 bolts on the perimeter (Fig. 7) (Horyl & Šňupárek, 2007).

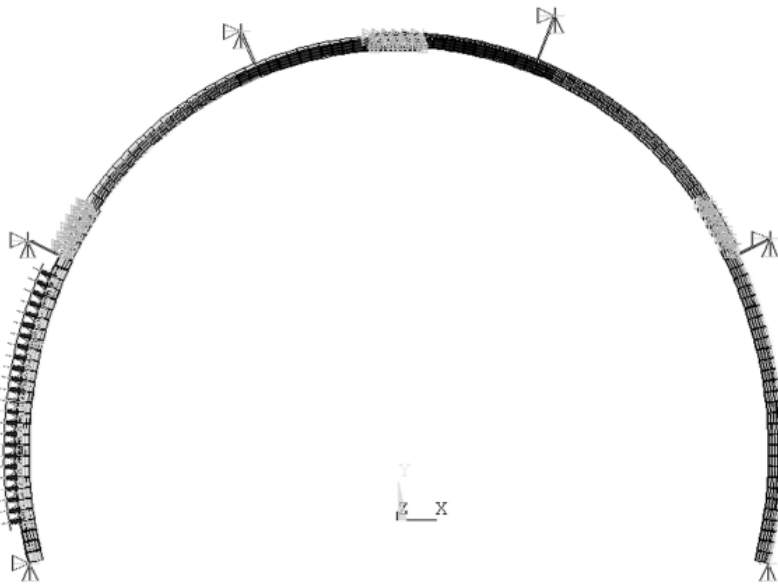

Fig. 7. Scheme of anchored support

A grouted steel bar bolt, with a 25 mm diameter and a tensile loading capacity of 250 kN, was considered.

The free length of the bolts, (distance between fixed connection with arch support and anchored part of bolt) was 400 mm. From the results of the modeling presented in Fig. 6 it seems clear that anchoring the support significantly reduces the value of strain energy by 13-16 kJ, which represents 36-44% of whole strain energy for this case.

The results of modeling, as well as field observations, show that effective anchoring of the arch support to surrounding rock with rockbolts causes a significant increase in the resistance of the construction, especially to dynamic loads (Horyl & Šňupárek, 2007).

4. Model of breakthrough support

Contemporary in rockburst prone areas, the high proportion of rockbursts in break-throughs is significant (Šňupárek & Zeman, 2005). Cross entries are mostly driven under the roof of a seam. The steel support consists of straight roof beams, side arches and corner segments. A common steel support with a breakthrough width 6,5 m, which was modeled, is shown on the Fig. 8.

Support from steel rolled profile weight 28 kg/m contains yielding friction connections (Fig. 3). Steel bolts which anchored support to the roof were modeled as amplifying elements (Fig. 9). The modeled support segment with rockburst impact is shown in the Fig. 10, and the scheme of modeled tasks is shown in the Fig. 11.

The development of the strain energy accumulated in the support was considered to be as important as the indicator of resistance of the support and the effect of reinforcing measures. The accumulation of total energy is not very different in individual cases. But when we compare

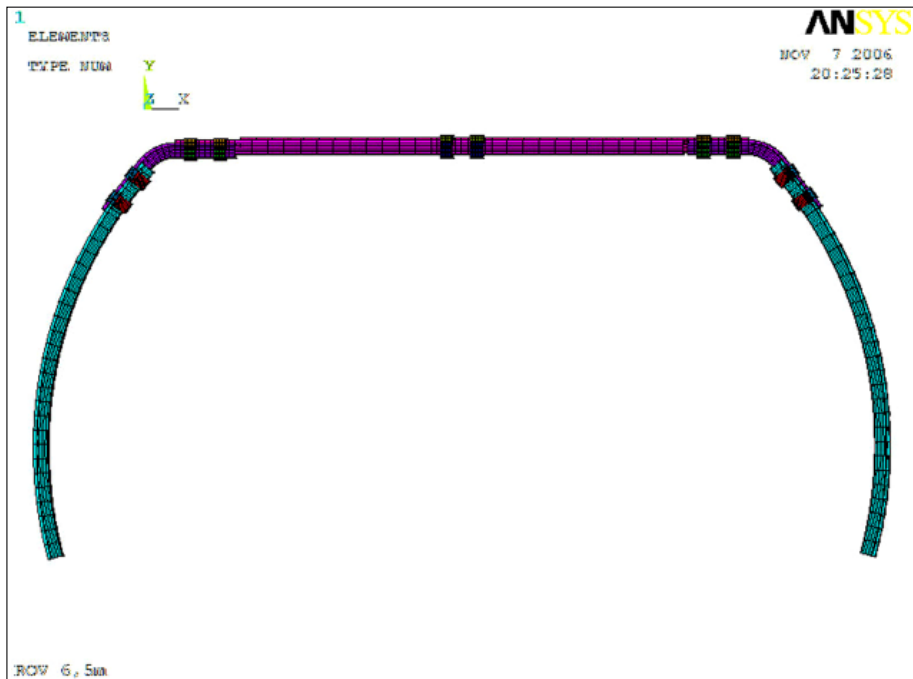

Fig. 8. Numerical model of the support structure

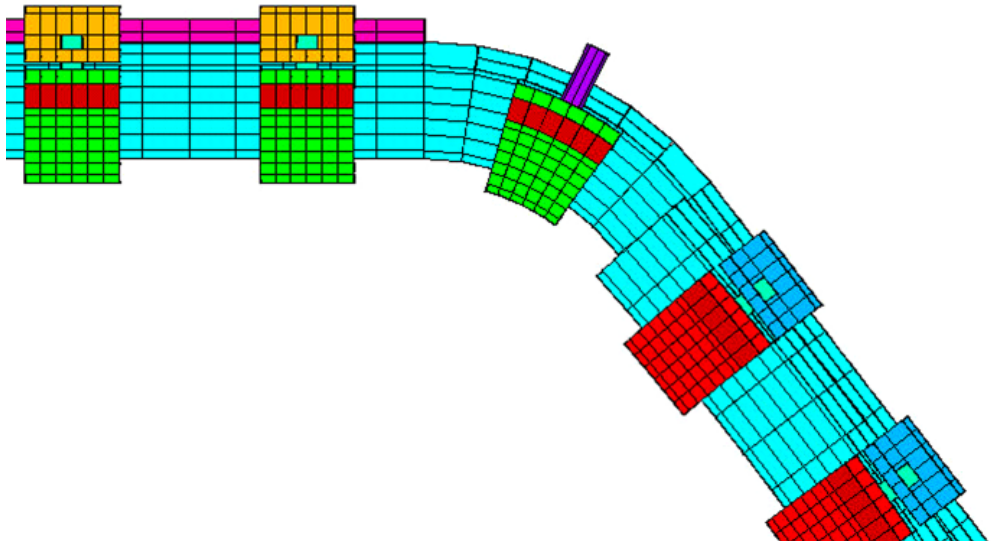

Fig. 9. Pair of bolts in the corner segment

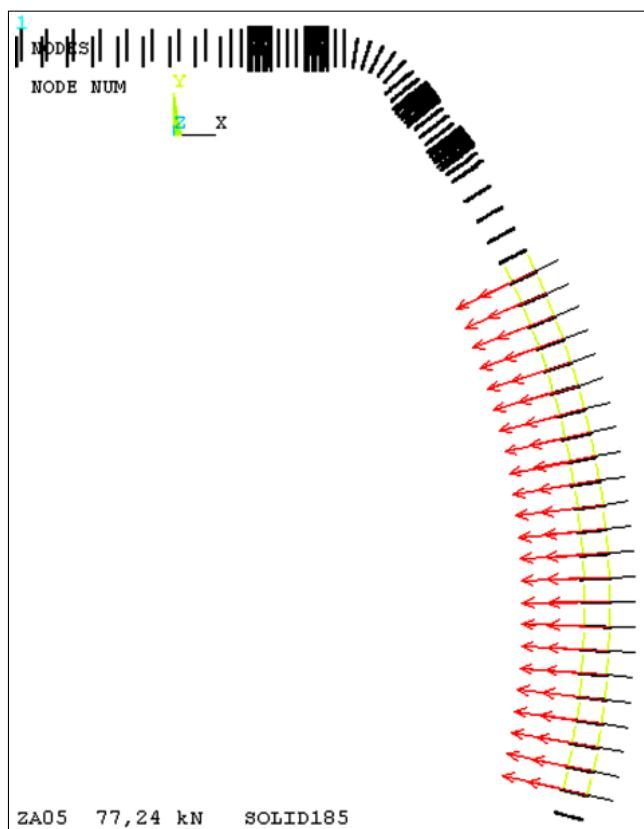

Fig. 10. Nodes of acting of power impulse on the support

values of accumulated (lost) energy in the bolts, connections, screws, and surrounded environment (through backfill), the differences are more significant. It is seen in all models that the more rigid the construction is the less energy is accumulated in the proper support.

and more energy is swallowed up in other parts (bolts and backfill, friction energy in connections, deformation energy of screws). Fig. 12 demonstrates values of the „lost“ energy in the 5 model cases. The detailed course of the energy in the support construction is described in the Fig. 13.

At first it is a comparative model P4 - support with non functional (rigid) connections. Lost energy can appear only in the strain energy of the backfill, which is a marginal value. Approximately 2 kJ (cca 5% of the total deformation energy) is the value of lost energy in the model N4C with standard connections. More than 3 kJ (cca 8%) is the value of lost energy in the model N5C with 2 roof bolts, and cca 9 kJ (24%) is the value of lost energy in the model N6C with bolts in roof and in corner arches. The maximal value of lost energy – 11,5 kJ (29,7%) occurs in the model N7 with two pairs of bolts in both corner segments. It is also demonstrated in the fig. 13, where the detailed course of the energy for model N7 is shown. The share of the lost strain energy, which really does not occur in proper steel arch construction, represents increase of dynamic resistance of the strengthened support.

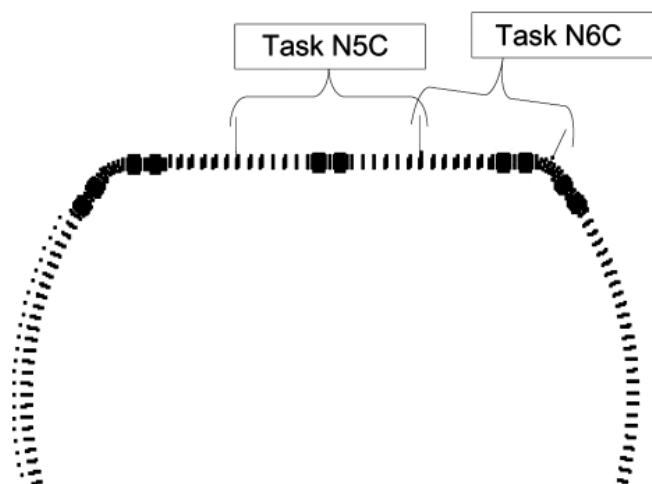

Fig. 11. Scheme of modeled tasks

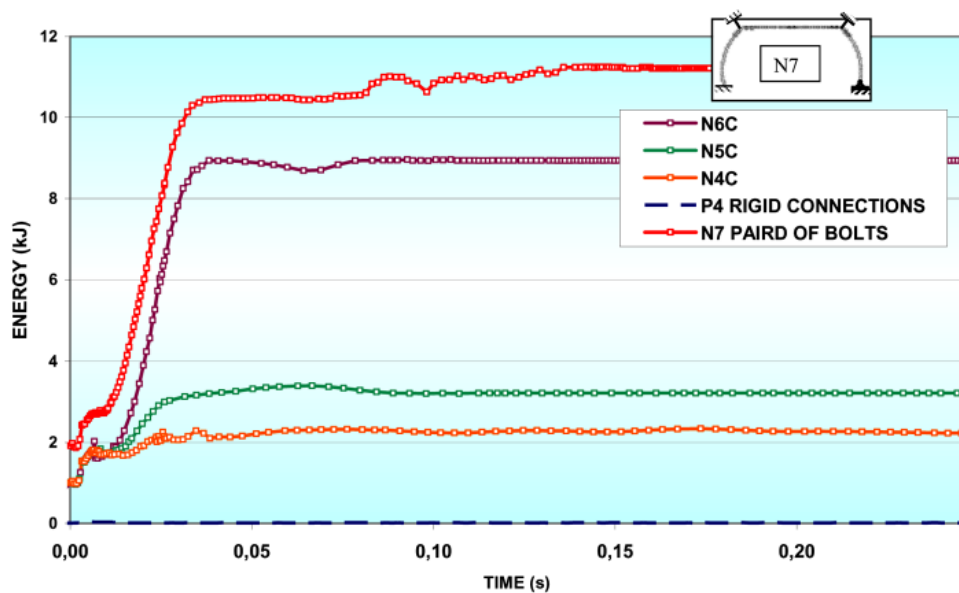

Fig. 12. Course and comparison of lost energy in the modeled tasks

In the final stage of computing we focused on more detailed modeling of the complementary rockbolts under dynamic loading, starting with the stress patterns in their cross section. We consider the similar scheme like some authors (Nierobisz, 2006), but the bolts were loaded by combined stress (tensile and bending stress). The rockbolts were modeled like beam elements carrying tense, pressure, 3D bending and torsion. Virtually removing a bolt in the moment of

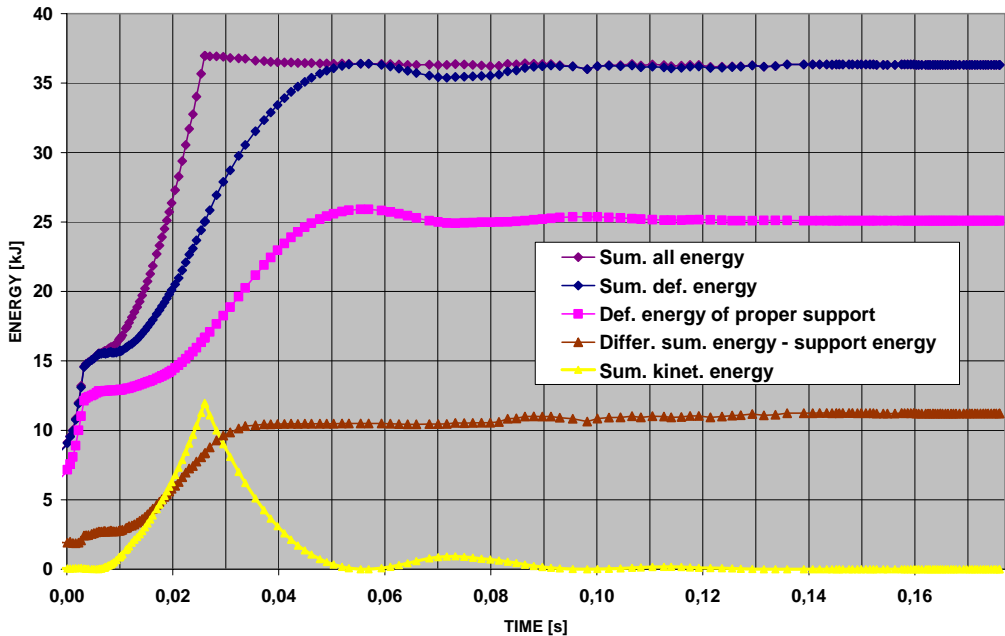

Fig. 13. Course of energy in the support with two pairs of bolts in corners (N7)

receiving an over yield point in the steel was implemented into the code because of to expected huge loading of the complementary bolts (order EKILL).

Stress values in the bolts were established in the used code ANSYS via the special tool SECTION. Each defined cross section is divided into several parts (there are not finite elements). Our circle bolt section is modeled like an octagon). The code calculated stress components in points of intersection and in corners of the section, in the case of 17 points (Fig. 14). Stress distribution in the cross section is shown on the Fig. 15.

During a dynamic process we had to determinate the instant of bolt failure and to investigate how the new boundary condition influences behavior and energy development in the support construction. The instant of bolt failure was determinated to be in the same moment when 80% of 17 calculated points have gone beyond the yield point of material. In the moment an internal order EKILL is applied.

The instant when bolt failure occurred the loading was approximately 2000 N (in one node), which is about double the value of early modeled cases. The instant of bolt failure (more than 80% of the section moved into the plastic state) occurred at 0.08 sec in the bolt on the side of impulse. The order EKILL was implemented at this time (Fig. 16). Dynamic loading of construction (impulse of force) ended in the time 0.03 sec, vibration of the support construction lasts to 0.2 sec

A history of deformation energy in a complementary bolt including its failure is demonstrated in the Fig. 17 It is obvious that the bolt has been stressed during the impulse of force and mainly during vibration immediately after the end of the impulse.

The development of deformation energy in the whole support (corresponding with the model N7) is shown in the Fig. 18. Vertical lines show the decisive moments of the simulation (impulse

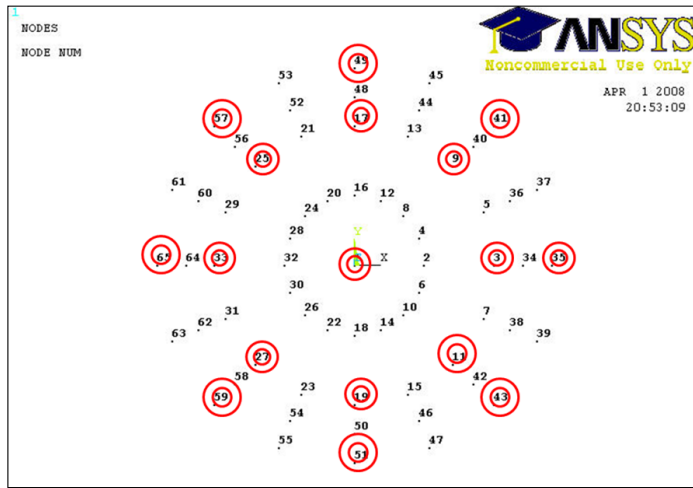

Fig. 14. Model of cross section of bolt

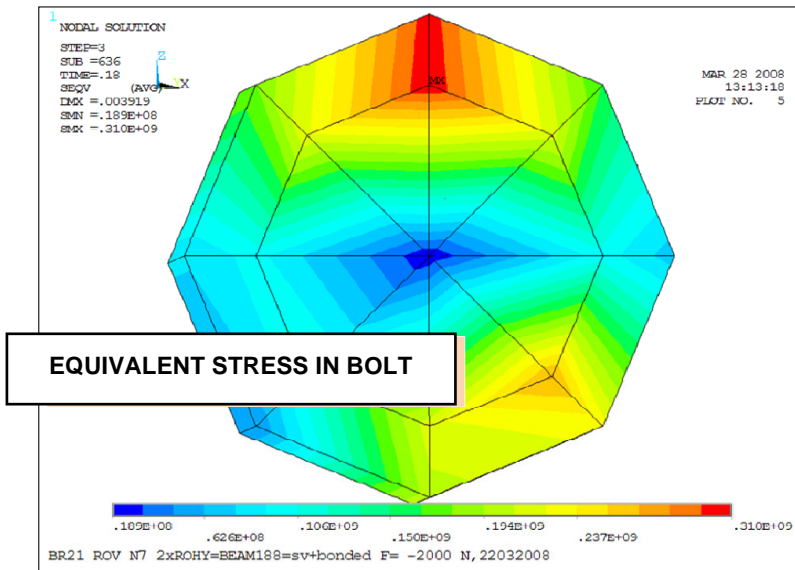

Fig. 15. Stress distribution in bolt cross section

of force and failure of bolt). Dot-and-dash line represents strain energy in the proper steel arch support. The difference between the strain energy in arch support and a total deformation energy (dot line) represents lost energy accumulated in bolts, yielding connections and packing. The more lost energy that is accumulated in bolts and connections the less strain energy that occurs in proper steel standing support. From the course of energy history during dynamic loading, it

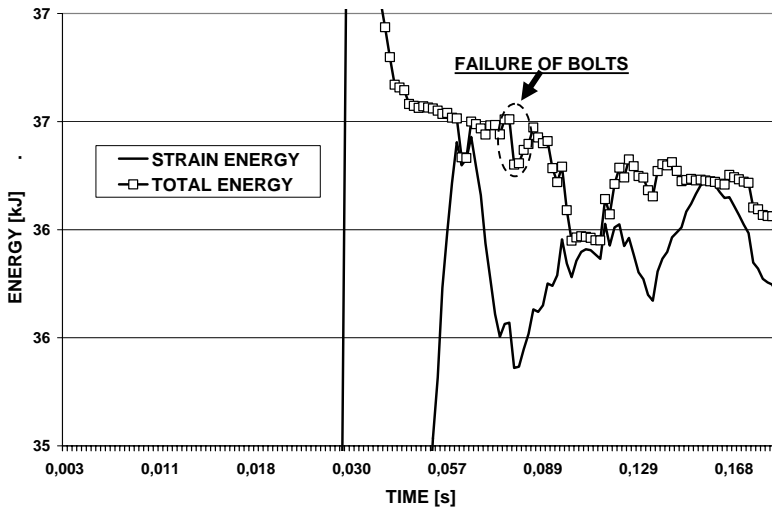

Fig. 16. Course of energy in bolt during dynamic loading

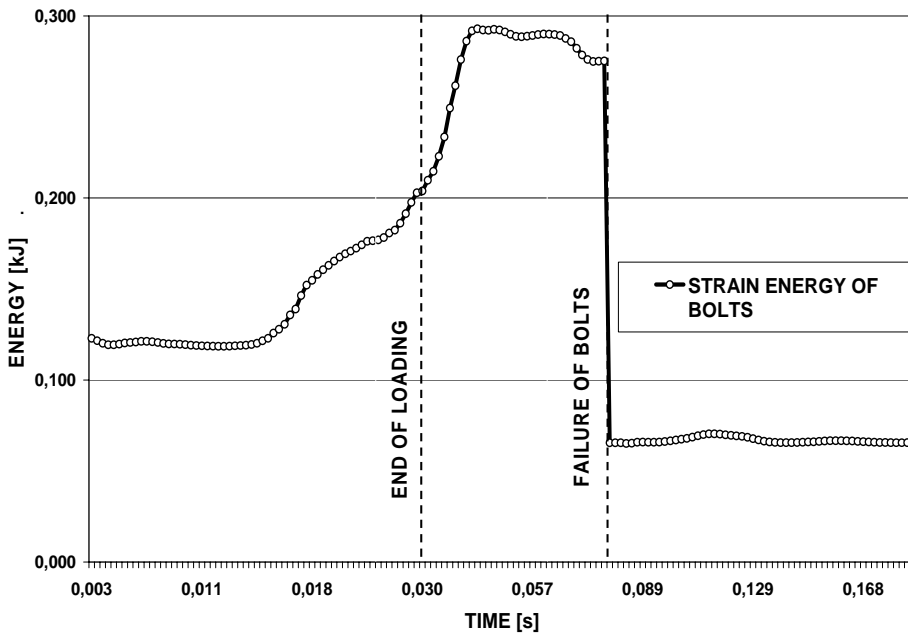

Fig. 17. Course of deformation energy in a bolt including its failure

follows that only little a change of energy comes after rockbolt failure. It is decisive that rockbolts are active during dynamic loading when they increase stiffness and natural frequency of the support construction and decrease loading of steel standing support. The rupture of bolts occurs

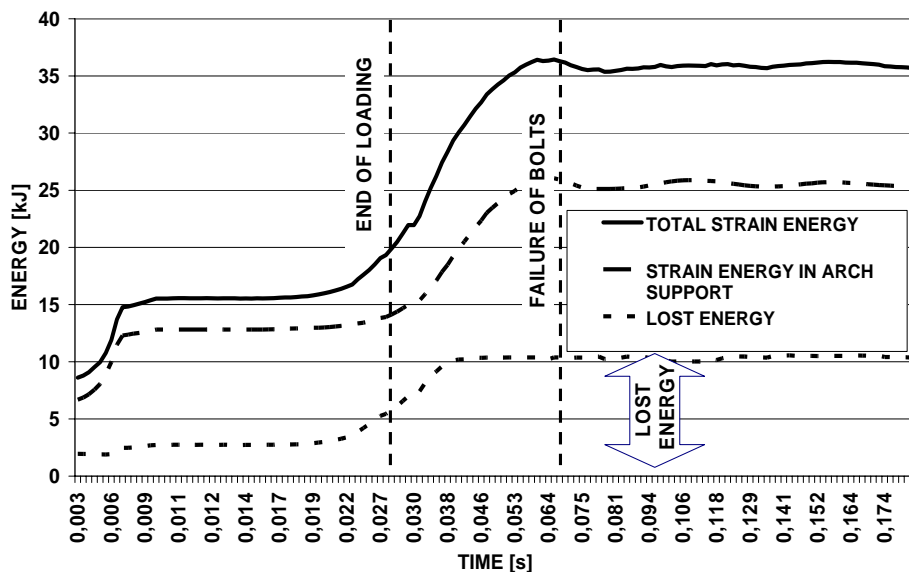

Fig. 18. Course of energy in anchored support

after the ending of impulse of force in the stage of tail vibration. Despite the failure of rockbolts on the side of the dynamic impulse in the stage, the behavior of a support construction almost does not change. The main work of bolts is manifested before their failure.

5. Conclusion

The analysis of rockburst effects in the Ostrava Karviná Coal Basin demonstrates that the impact of rockbursts on gate roadways and breakthroughs are distinctly more intense than on the adjacent longwall face areas. Increasing of dynamic resistance of roadway supports seems to be very useful. Modeling of effective strengthening measures of roadway support was the main objective of investigations.

On the basis of an inverse analysis of the support deformations, the impact of rockbursts were modeled as an impulse of force for the duration of 0,02 s with a maximum force from 1000 N to 2000 N (acting in each node) from the side of the roadway. The development of strain energy accumulated in the support was considered to be as important as the indicator of resistance of the support. The values of lost energy in bolts, connections, screws, and the surrounded environment (through backfill) which decrease a strain energy in the proper steel support, are indicators of effectivity of strengthening measures.

Mathematical modeling of the effect of strengthening bolts during dynamic loading of the steel support of breakthroughs confirmed that the correct application of anchors significantly increases stiffness of the support and its dynamic resistance. A location of strengthening bolts has a huge importance for increasing of dynamic resistance of the support. The location of bolts in the part of ceiling bar brings decrease of strain energy in proper support by 8%. It means that

the often used location of complementary bolts in straight part of the breakthrough support in the roof has a marginal influence on the dynamic resistance of the support in case of a side impact. The location of one pair of bolts in the corner arch decreases the strain energy in steel support by 24% and the optimal location of bolts in the both corner arches brings decrease of strain energy in the support almost by 30%.

In the final stage of computing we focused on more detailed modeling of the complementary rockbolts under dynamic loading including a failure of bolts. The instant of bolt failure (more than 80% of the section moved into the plastic state) occurred at 0.08 sec in the bolt on the side of impulse. The rupture of bolts occurs after the ending of impulse of force in the stage of tail vibration. From the course of energy history during dynamic loading, it follows that only little a change of energy comes after rockbolt failure. Despite the failure of rockbolts on the side of the dynamic impulse in the stage, the behavior of a support construction almost does not change. The main work of bolts is manifested before their failure.

Even in the case of bolt failure because of a high dynamic load the complementary bolts cause a significant decrease in strain energy accumulated in the steel standing support.

Acknowledgements

The paper has been done in connection with project Institute of clean technologies for mining and utilization of raw materials for energy use, reg. no. CZ.1.05/2.1.00/03.0082 and IT4 Innovations Centre of Excellence project, reg. no. CZ.1.05/1.1.00/02.0070 supported by Operational Programme "Research and Development for Innovations" funded by Structural Funds of the European Union and state budget of the Czech Republic.

References

- Albrecht J., Potvin Y., 2005. *Identifying the Factors that Control Rockbursts Damage to Underground Excavations*. Proc. Of RaSiM6 Controlling Seismic Risk, Perth, pp. 519-528.
- Horyl P., Šňupárek R., 2007. *Behaviour of steel arch supports under dynamic effects of rockbursts*. Mining Technology, Vol. 116, No. 3, pp. 119-128.
- Horyl P., Šňupárek R., 2009. *Rockbolts as Reinforcing Elements under Dynamic Impact of Rockbursts*. Proc. Sinorock 2009, Hongkong pp.
- Kidybinski A., 2011. *The role of geo-mechanical modeling in solving problems of safety*. Arch. Min. Sci., Vol. 55 (2010), No 2, p. 263-278.
- Konečný P., Velička V., Šňupárek R., Takla G., Ptáček J., 2003. *Rockbursts in period of mining activity reduction in Ostrava-Karviná Coalfield*. In Proc. of 10th ISRM Congress, Sandton, Vol. 1, pp. 665-668.
- McGarr A., 1997. *A Mechanism of High Wallrock Velocities in Rockbursts*. Pure Application Geophysics 150, pp. 381-391.
- Nierobisz A., 2006. The model of dynamic loading of rockbolts, Arch. Min. Sci., Vol. 51, No 3, p. 453-470.
- Stacey T.R., Ortlepp W.D., 2000. *Support appropriate for dynamics loading and large static loading in block cave mining openings*. Proc. MassMin2000 Brisbane, pp.783-789.
- Šňupárek R., Zeman V., 2005. *Rockbursts in longwall gates during coal mining in Ostrava-Karviná coal basin*. In Proc. of EUROCK '05 Impact of Human Activity on the Geological Environment Brno, pp. 611-616.

Received: 04 April 2011