

AIMETA 2017
XXIII Conference

The Italian Association of Theoretical and Applied Mechanics
Luigi Ascione, Valentino Berardi, Luciano Feo, Fernando Fraternali and Antonio Michele Tralli (eds.)
Salerno, Italy, 4-7 September 2017

THE EUROPEAN PROJECT SUREBRIDGE – A CASE STUDY IN TUSCANY

Paolo S. Valvo¹, Erika Davini¹, Cristiano Alocci¹, Antonfranco Pasquale²,
Fabio Ricci², Juan Carlos Miranda Santos², Martijn Veltkamp³, Reza Haghani⁴

¹ Department of Civil and Industrial Engineering, University of Pisa
Largo Lucio Lazzarino, 56122 Pisa, Italy
e-mail: p.valvo@ing.unipi.it

² A.I.C.E. Consulting S.r.l.
Via G. Boccaccio, 20, 56017 San Giuliano Terme (Pisa), Italy
e-mail: a.pasquale@aiceconsulting.it

³ FiberCore Europe
Oostdijk 25, 3077 CP Rotterdam, The Netherlands
e-mail: veltkamp@fibercore-europe.com

⁴ Department of Civil and Environmental Engineering, Chalmers University of Technology
Sven Hultins gata, 8, 412 96 Gothenburg, Sweden
e-mail: reza.haghani@chalmers.se

Keywords: road bridges, structural strengthening, fibre-reinforced composite materials.

Abstract. *The European project SUREBridge (Sustainable Refurbishment of Existing Bridges) is developing a new concept for the refurbishment of road bridges. The proposed technique takes advantage of the peculiarities of fibre-reinforced materials to perform upgrading, repair, and strengthening in an effective and efficient way in terms of resource consumption, waste production, construction time, and traffic disruption.*

The technique applies to bridges with reinforced concrete slab and longitudinal girders made of either reinforced concrete or steel. Longitudinal girders are strengthened by bonding carbon fibre-reinforced polymer (CFRP) laminates to their bottom surfaces. Higher structural performances are achieved by pre-stressing the CFRP laminates. The existing concrete slab is not demolished, with savings in both construction time and waste production. Instead, tailor-made glass fibre-reinforced polymer (GFRP) panels are connected to the deck to increase its overall bending strength. Furthermore, GFRP panels enable the widening of the road section, if necessary to upgrade the bridge to increased traffic demand.

This paper presents the application of the SUREBridge technique to a real bridge located in San Miniato, Tuscany, Italy. The designed intervention includes both the widening of the road section and the structural strengthening of the deck to comply with current traffic loads.

1 INTRODUCTION

Bridges are critical transport infrastructures, fundamental for the performance of the road and railway transport network. Today, bridge owners and managers are dealing with a large number of structurally deficient and obsolete bridges. With the expected increase in the traffic volume, existing bridges will be subjected to more severe actions and, consequently, the need to refurbish these infrastructures will increase dramatically. In this context, refurbishment includes not only structural strengthening, repair, and upgrading, but also geometric changes, such as the widening of the bridge deck to provide more traffic capacity.

At present, construction and maintenance activities relating to bridges imply economical and time expensive procedures, with a negative impact on traffic flow and welfare in wider terms. In addition to disturbance, disruption, and pollution, other main challenges are the inefficient use of resources, i.e. materials, energy, waste management, and recycling.

In this paper, we present an innovative solution developed within the European project SUREBridge for the refurbishment of road bridges along with its application to a real bridge selected as case study.

2 THE SUREBRIDGE PROJECT

2.1 Basic concept

The European research project SUREBridge (Sustainable Refurbishment of Existing Bridges) is developing a new concept for the refurbishment of road bridges. The proposal is addressed to concrete and steel-concrete bridges, which are usually affected by strength deficiencies linked to the concrete slab [1].

The target is to exploit the remaining capacity of the superstructure, preserving the structural elements of the deck (girders and slab) and increasing the load-carrying capacity to the desired level. This is achieved by using light-weight, tailor-made glass fibre-reinforced polymer (GFRP) sandwich panels [2], installed on the existing concrete slab, and carbon fibre-reinforced polymer (CFRP) laminates applied to the bottom side of the girders. Such laminates are pre-stressed using an innovative technique, which avoids tensional peaks at the laminate ends [3]. Furthermore, the GFRP panels can be manufactured of the same width or wider than the existing deck, as shown in Figure 1, enabling to widen the road section if needed.

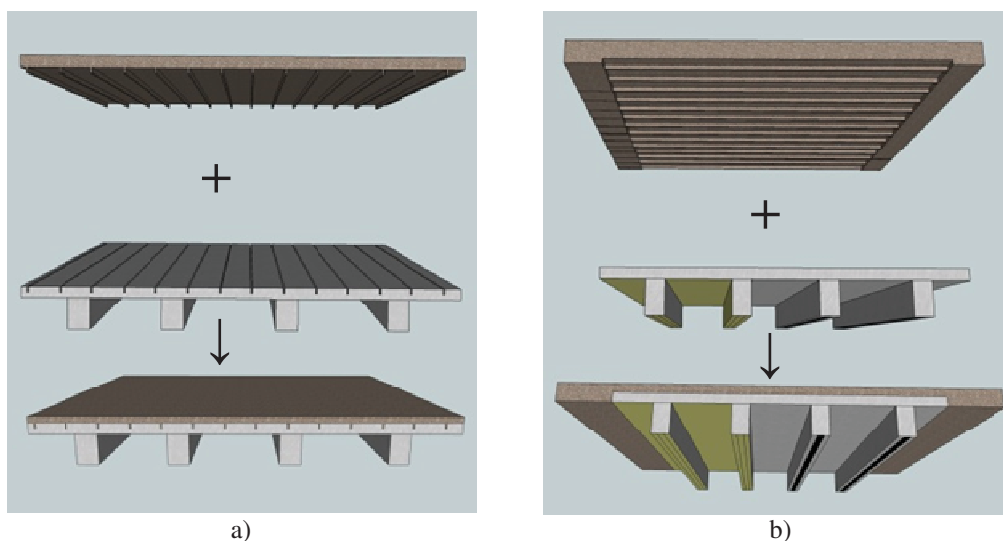

Figure 1: a) Refurbishment and b) Refurbishment and widening of an existing bridge deck.

2.2 Theoretical and experimental behaviour of FRP strengthened beams

Figure 2a shows the cross section of a reinforced concrete beam, chosen as a prototype to demonstrate the effectiveness of the strengthening technique developed within the SURE-Bridge project. This T-shaped cross section schematically represents the typical girder and slab elements used in road bridges. Figure 2b illustrates the same cross section strengthened with the SUREBridge technique.

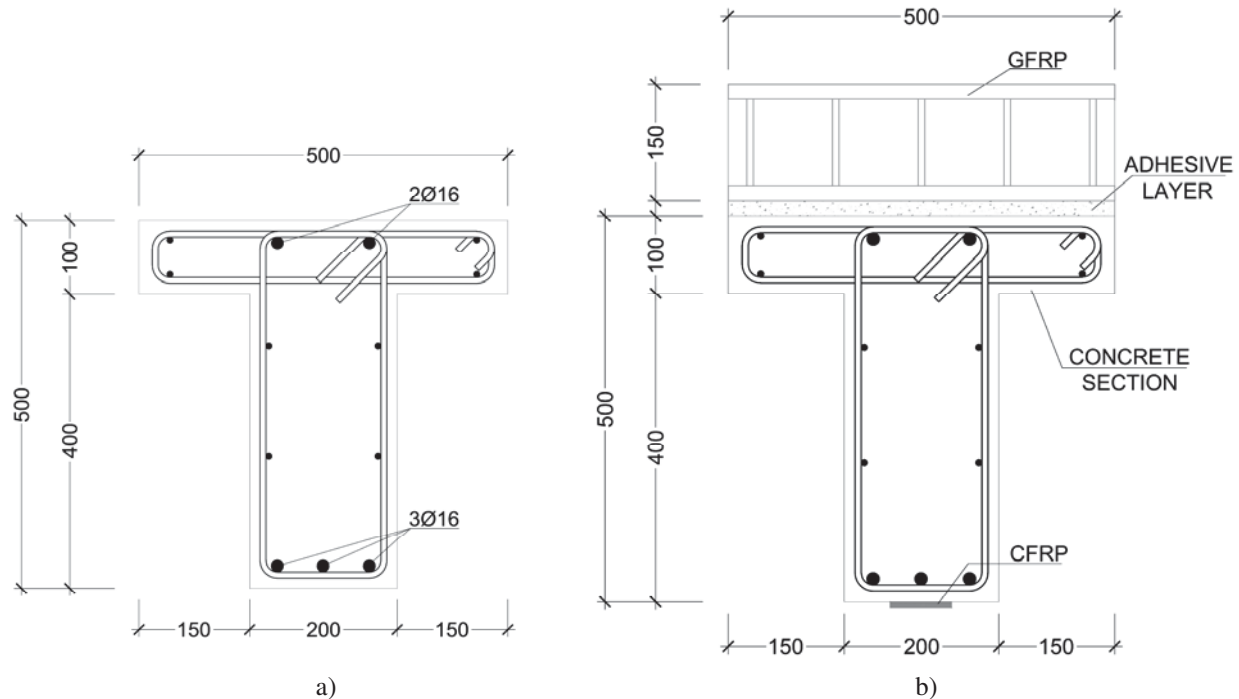

Figure 2: Prototype reinforced concrete beam: a) un-strengthened; b) strengthened.

Large-scale, 6-m long specimens having the described cross sections are currently (July 2017) being tested under four-point bending (Figure 3) in the laboratory of the Structural Engineering Division of the Department of Civil and Environmental Engineering at Chalmers University of Technology.

The resisting bending moment of the strengthened composite section, M_{rd} , has been evaluated by extending to the present case the normally accepted hypotheses for ultimate limit state (ULS) verifications of reinforced concrete elements (Section 6.1 of Eurocode 2 [4]):

- plane sections remain plane with no relative sliding between concrete and steel;
- the tensile strength of concrete is ignored;
- the stresses in concrete in compression are derived from the design stress-strain relationships given in Section 3.1.7 of Eurocode 2 [4]. In particular, here a bilinear stress-strain relationship has been used;
- elastic-plastic behaviour is assumed for steel reinforcements.

In addition to the above, further specific assumptions have been made:

- the whole composite section remains plane after deformation with no relative sliding between CFRP/GFRP elements and concrete;
- both CFRP and GFRP are assumed to behave as elastic-brittle materials;
- delamination of CFRP/GFRP from concrete is not taken into account.

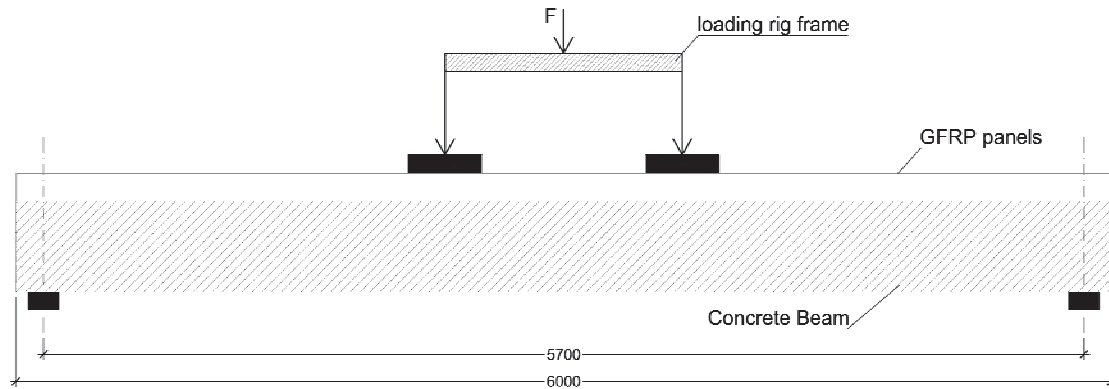

Figure 3: Test configuration for strengthened prototype beam.

Analytical details about the resulting mechanical model are omitted here for brevity, but can be found in a dedicated deliverable of the project [5]. The model has been implemented into a software tool, which furnishes the ultimate bending moment of the strengthened section.

To validate the above-mentioned hypotheses, non-linear static analyses have been carried out on refined finite element models of the large-scale prototype beams using the commercial software Straus7® [6]. A fibre-element modelling approach, frequently used for push-over seismic analyses, has been chosen since it represents a good compromise between simplicity of implementation and accuracy of results in material non-linear analyses [7] [8].

Figure 4 shows the un-strengthened and strengthened cross sections of the modelled beams. The mechanical properties of the materials are summarised in Table 1.

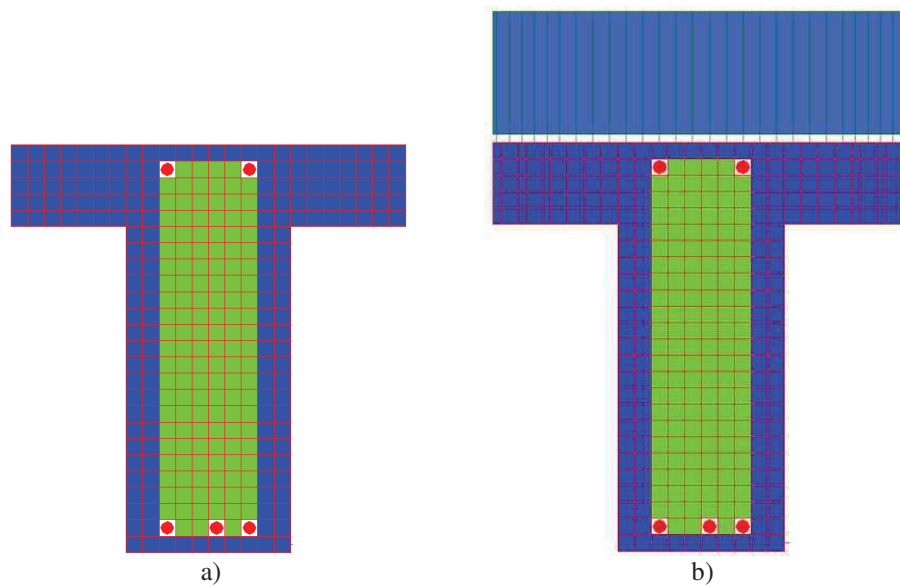

Figure 4: Finite element model for a) un-strengthened beam; b) strengthened beam with the SUREBridge solution.

	Characteristic strength (MPa)	Elastic modulus (MPa)
Concrete (in compression)	43	34077
Steel	500	210000
CFRP	3000	210000
GFRP (webs in longitudinal direction)	491	38200

Table 1: Mechanical properties of the materials.

Figure 5 shows the theoretical load-deflection curves obtained from analyses in terms of the total applied load, F , and mid-span deflection. Table 2 compares the finite element analyses results and the predictions made with the software tool on the ultimate bending moment, M_{rd} , and the corresponding failure load, F_u .

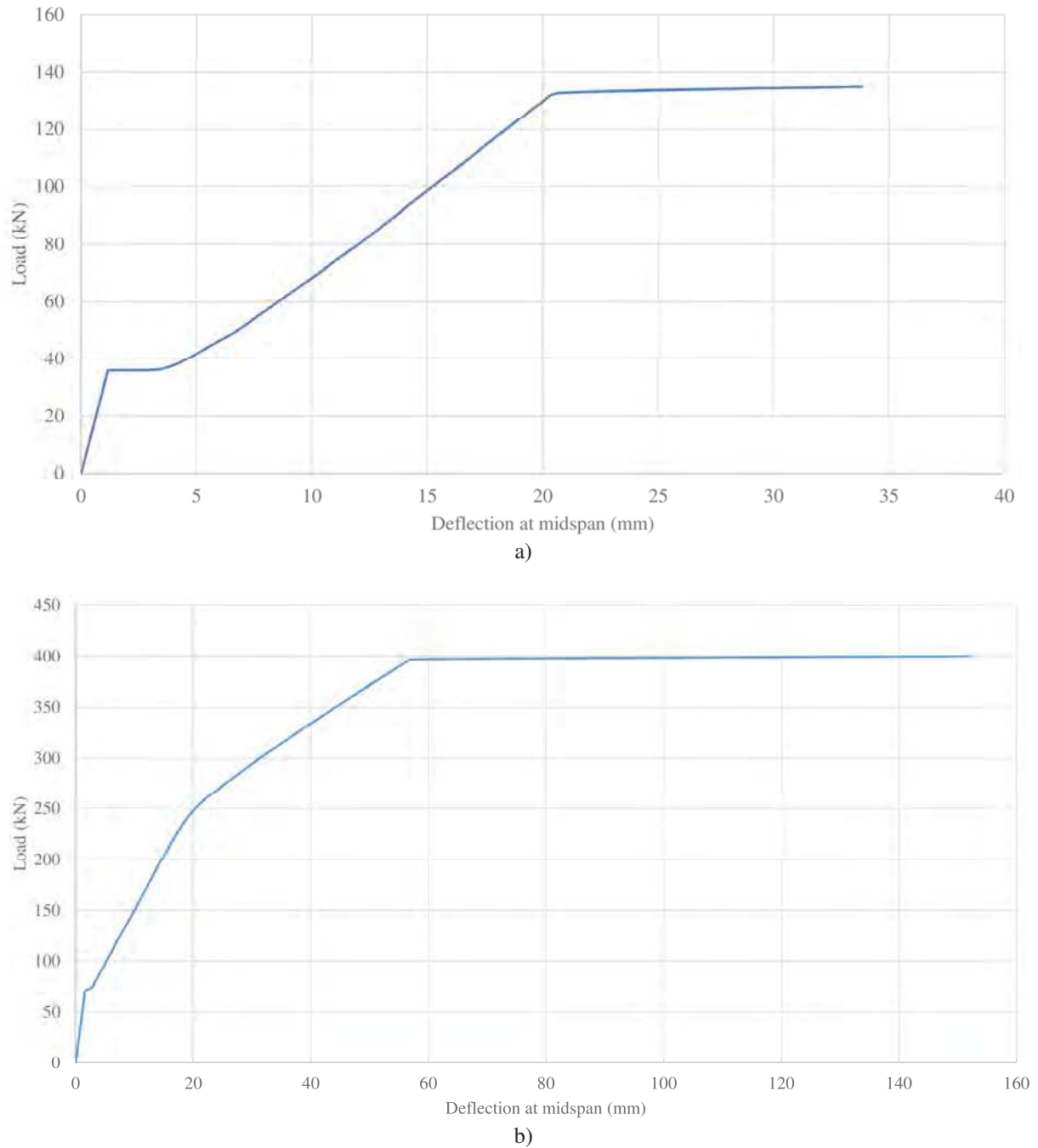

Figure 5: Load-deflection curves: a) un-strengthened beam; b) strengthened beam.

	Software tool		Finite element analysis	
	F_u (kN)	M_{rd} (kNm)	F_u (kN)	M_{rd} (kNm)
Un-strengthened beam	126	139	135	148.5
Strengthened beam	418	460	397	437

Table 2: Comparison between the results of the software tool and the finite element analysis.

3 STRUCTURAL ANALYSIS OF THE SAN MINIATO BRIDGE

3.1 A case study in Tuscany: the San Miniato bridge

In order to evaluate the effectiveness of the SUREBridge solution, its application to a real bridge has been analysed [9]. The selected case study is a bridge crossing the Elsa river and located in a small town named Isola di San Miniato (Tuscany, Italy), from now on referred to as the “San Miniato bridge” (Figure 6).

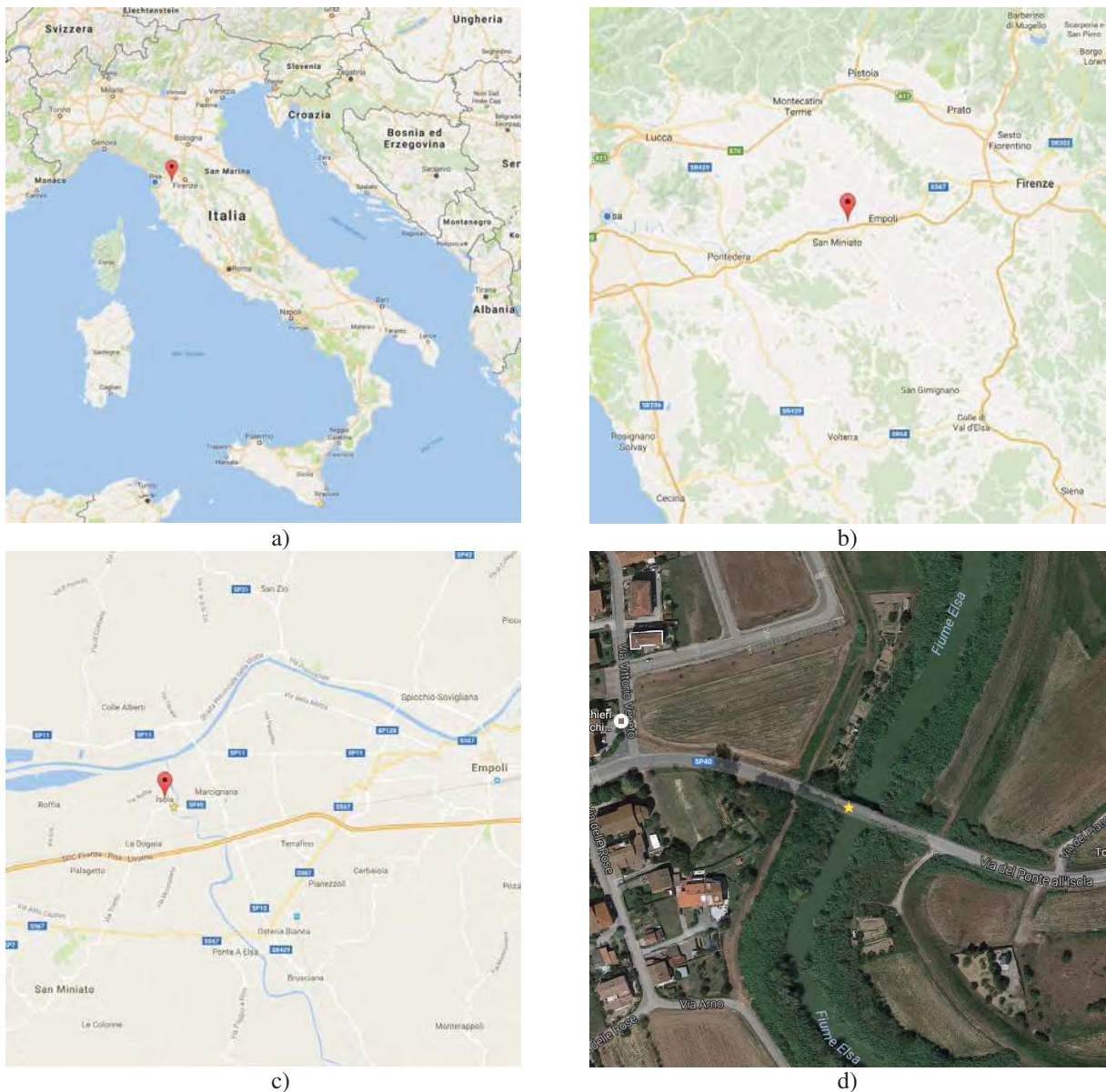

Figure 6: Location of the San Miniato bridge: a) in Italy; b) within Tuscany; c) within the Municipality of San Miniato; d) satellite view of the bridge.

The bridge has a length of nearly 60 m subdivided into four spans of 15 m each. The 3-m wide deck, crossed by vehicles one way alternatively, is composed of a 160-mm thick, cast-on-site concrete slab and four prefabricated pre-stressed concrete girders, 1 m high and 1 m distant one from another.

The original documents indicate that the bridge was designed by the Italian engineer Francesco Lorenzi and built in 1968. The construction was motivated by the collapse of a pedestrian iron bridge, caused by the riverbed lowering and constant erosion of the banks. Such phenomena were in turn due to the strong flows and vortices between the Arno river and a nearby dyke, collapsed too some years later.

3.2 Structural investigations

The San Miniato bridge has been the subject of a structural investigation conducted in 2006 by the engineering company A.I.C.E. Consulting S.r.l. The Client was the Province of Pisa, as the Authority owning the bridge and responsible for its maintenance. After the damage of a railing, the Client had decided to lead an investigation campaign on the bridge to highlight possible other degradation issues and to evaluate the residual load-carrying capacity.

The first step of the investigation campaign was an on-site visual inspection (Figure 7a). From this inspection, some of the main problems affecting the bridge were immediately apparent: corrosion and breakage of some pre-stressing wires (Figure 7b), concrete spalling and reinforcement corrosion (Figure 7c), and general degradation of concrete surfaces (Figure 7d).



Figure 7: Visual inspection on the bridge: a) General view; b) Corrosion of pre-stressing wires; c) Concrete spalling and reinforcement corrosion; d) Degradation of concrete surfaces.

A survey and testing plan was developed involving sclerometric and ultrasonic tests, as well as dynamic acquisitions. The values of the mechanical properties of concrete to be used in structural modelling and verifications were obtained from *in-situ* tests. Instead, since the types of steel used in the construction were clearly indicated in the original design documents, it was decided not to take samples of reinforcement bars and wires, but only to verify their

positions and diameters by using a pacometer and make spot checks by removing the superficial concrete layers.

From dynamic acquisitions, the natural frequencies and mode shapes were obtained. These were later used to calibrate the finite element model of the bridge. The first natural frequencies obtained were 8.6–9.2 Hz for the flexural modes and 12.5–13.3 Hz for the torsional modes, as can be seen in Table 3, where the notation “ADx” indicates the dynamic test done at a specific point of the structure (Figure 8).

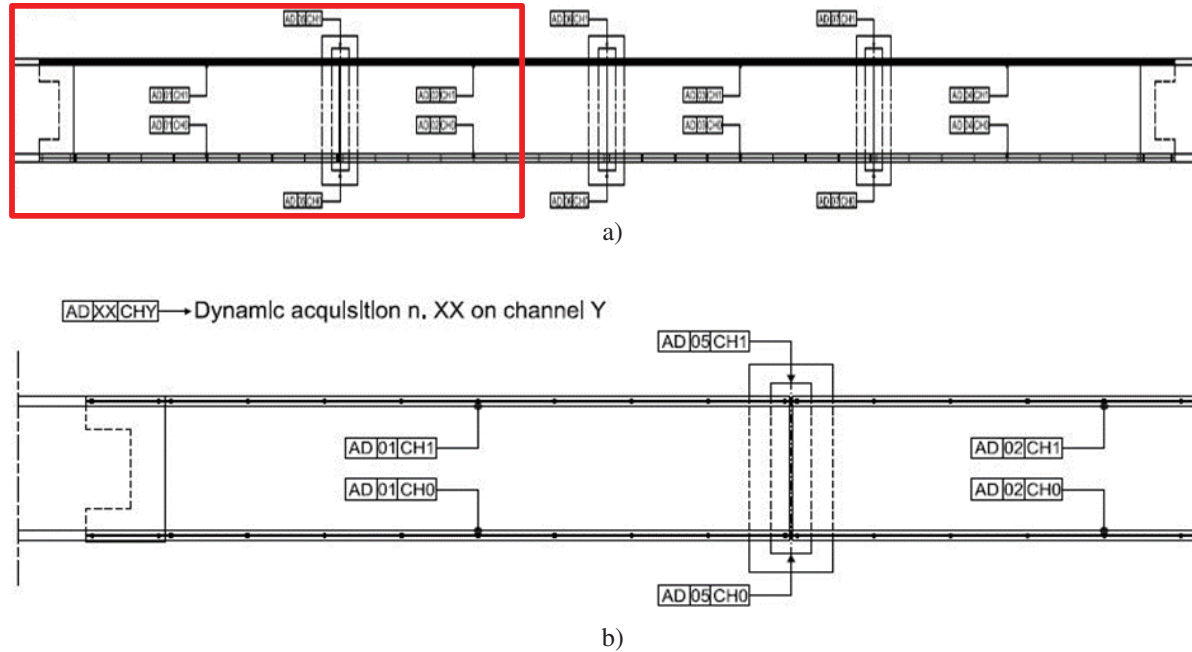

Figure 8: Position of the dynamic acquisitions: a) plan view of the whole bridge; b) detail of the first span.

Test	Channel	f_1 (Hz)	f_2 (Hz)
AD1	CH0	9.2	12.9
	CH1	9.2	12.9
AD2	CH0	8.6	12.5
	CH1	8.6	12.5
AD3	CH0	8.9	13.3
	CH1	8.9	13.3
AD4	CH0	8.6	–
	CH1	8.6	–

Table 3: Experimental natural frequencies.

3.3 Finite element model of the existing bridge

A finite element model of the bridge (Figure 9) has been created by using the commercial finite element software Straus7® [6]. The outcomes of the experimental campaign were used to define the geometry of the BEAM and PLATE elements, as well as the mechanical properties of the materials, the internal and external constraints. Table 4 summarises the mechanical properties of the materials, obtained from the original documents and the *in-situ* investigation campaign.

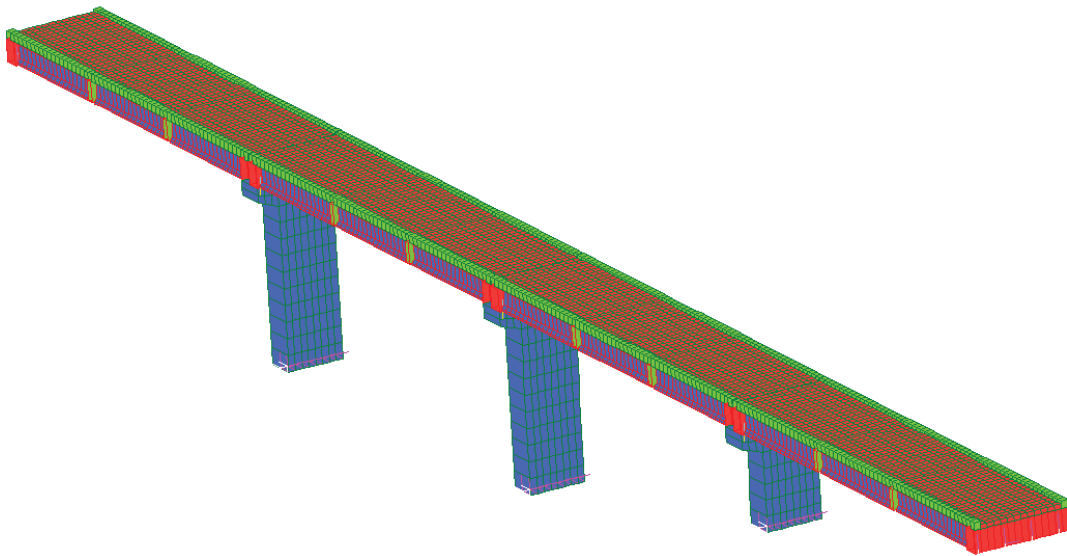

Figure 9: Finite element model of the bridge.

Part	Property	Value	Source
Girder	Unit weight	25 kN/m ³	literature
	Elastic modulus	36000 MPa	on-site ultrasonic test
	Poisson coefficient	0.1	literature
	Density	2500 kg/m ³	literature
Pier	Unit weight	25 kN/m ³	literature
	Elastic modulus	29500 MPa	on-site ultrasonic test
	Poisson coefficient	0.1	literature
	Density	2500 kg/m ³	literature
Slab	Unit weight	25 kN/m ³	literature
	Elastic modulus	31200 MPa	on-site ultrasonic test
	Poisson coefficient	0.1	literature
	Density	2500 kg/m ³	literature

Table 4: Mechanical properties of the materials.

3.4 Dynamic modal analysis

The dynamic modal analysis is needed to determine the theoretical natural frequencies and mode shapes of the structure to be compared with the experimental results obtained from *in-situ* dynamic acquisitions (see Section 3.2). No force loads were considered, but only the masses of the structural and non-structural elements, such as the road pavement and railing.

The mass of the structural elements is automatically calculated by the software and attributed to the nodes of the model, once the geometry and material properties of each element are defined, while the masses of the road pavement and railing are introduced into the model as NON-STRUCTURAL MASS per unit area of the PLATE elements representing the concrete slab. Table 5 summarises the natural frequencies of the first vibration modes obtained from the dynamic modal analysis of the structure. The modes with the higher mass participation factors are given in boldface character. A good agreement has been obtained between the experimental results (Table 3) and the output of the analysis, so that the model was considered well calibrated.

Mode	Theoretical frequency (Hz)	Mass participation factor		
		X (%)	Y (%)	Z (%)
1	6.435	16.702	0.000	19.681
2	6.585	0.000	56.824	0.000
3	7.233	0.139	0.000	0.288
4	8.308	1.046	0.000	0.002
5	9.259	1.636	0.000	35.624
6	9.676	0.000	0.048	0.006
7	10.72	0.000	2.313	0.000
8	11.08	0.000	5.809	0.000
9	11.52	60.099	0.000	8.151
10	12.40	0.000	0.062	0.000
11	12.47	0.000	1.365	0.000
12	14.86	0.000	16.276	0.000

Table 5: Theoretical and experimental natural frequencies.

3.5 Linear static analysis

The bridge was designed following the Italian regulations of the time of construction, namely the Circolare n. 1398/1965 [10] and the Circolare n. 384/1962 [11]. In order to assess the current load-carrying capacity of the bridge, static analysis of the model was carried out considering the load configurations and combinations according to the present Italian regulation NTC 2008 [12]. Such loads have been applied per unit area or unit length for the `PLATE` and the `BEAM` elements, respectively.

The stresses on the structural elements of the bridge have been determined for the single load cases and their combinations. The most unfavourable combinations used for structural verifications are presented in Table 6. Table 7 shows the strength demand obtained from the linear static analysis in terms of design bending moment, M_{sd} , and shear force, V_{sd} , compared to the corresponding capacities of the composite section (girder + concrete slab), M_{rd} and V_{rd} , evaluated according to NTC 2008 [12].

The structural analysis of the bridge has revealed that the composite girder sections present both flexural and shear strength lacks. In addition, pre-stressing has to be restored in one of the border beams featuring some damaged wires (see Figure 7b). Furthermore, the road section turns out to be not sufficient for the road category assigned to the San Miniato bridge by Italian road regulations [13], so that it needs to be properly widened. Lastly, local analysis of the concrete slab has highlighted the need for both flexural and shear strengthening of this element in the transverse direction.

Verification	Loads	Leading load	Traffic load configuration	Load combination
Bending moment	Self-weight (G1)	Traffic (Q _t)		1.3*G1+
	Permanent loads (G2)			1.5*G2+
	Wind (Q _w)			1.5*0.6*Q _w +
	Traffic (Q _t)			1.35*Q _t
Shear stress	Self-weight (G1)	Traffic (Q _t)		1.3*G1+
	Permanent loads (G2)			1.5*G2+
	Wind (Q _w)			1.5*0.6*Q _w +
	Traffic (Q _t)			1.35*Q _t

Table 6: Load combinations for the ULS verifications.

Section	M _{sd} (kNm)	M _{rd} (kNm)	V _{sd} (kN)	V _{rd} (kN)
Internal girder	1231	991	360	285
Border girder	1156	962	260	285
Damaged border girder	1156	721	260	285

Table 7: Maximum design internal forces and corresponding resistances.

3.6 Preliminary design of the strengthening intervention

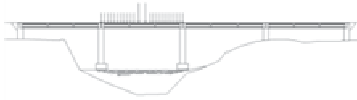
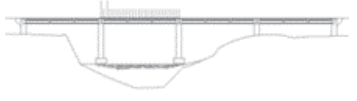
Several widening hypotheses have been evaluated to make the road section compliant with current Italian road regulations [13]. After a preliminary analysis, it was decided to choose a single lane solution with the widening of the existing deck from 3 to 3.5 m and the addition of two lateral walkways (Figure 10).

A new finite element model (Figure 11) representing the widened structure has been created to evaluate the increase in the demand. The resisting bending moment of the composite section, M_{rd} , at the ultimate limit state has been evaluated according to the hypotheses illustrated in Section 2.2. Table 8 shows the demand and capacity in terms of bending moment of the composite section obtained by using GFRP panels or CFRP laminates only, and the SUREBridge solution, which uses both. The benefits of the SUREBridge solution are clear: the ultimate bending moment can be considerably increased from 721 to 1484 kNm, above the design value of 1382 kNm. Furthermore, using the GFRP panels only would require very thick panels for the damaged border girder. In addition, using pre-stressed CFRP laminates only would imply a brittle failure of concrete in compression, since the limit strain of CFRP laminates has not been reduced with respect to material strength as prescribed by the Italian standard CNR-DT 200 R1/2013 to avoid intermediate delamination failure [14]. This limitation is valid just for passive laminates, due to the benefits of the CFRP pre-stressing technique on the concrete section [3].

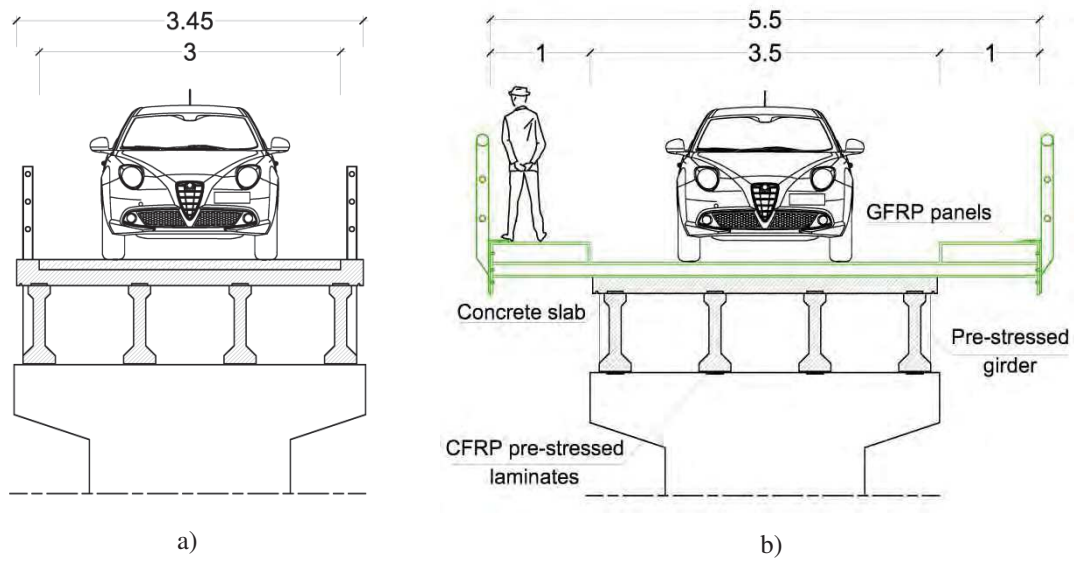

Figure 10: a) Existing cross section and b) widened cross section.

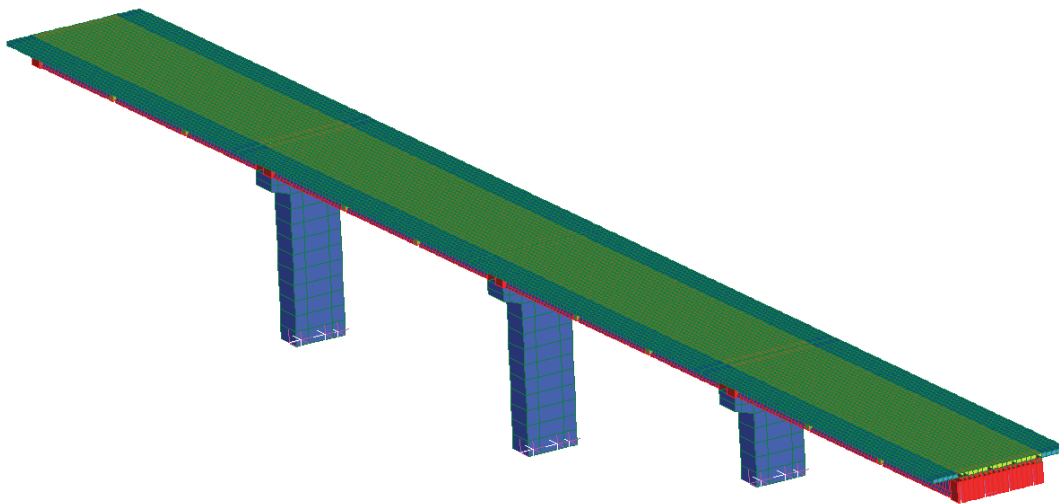

Figure 11: Finite element model of the widened bridge

Section	M_{sd} (kNm)	M_{rd} (kNm)			
	Widened	Existing	+ GFRP	+ CFRP	+ GFRP + CFRP
Internal girder	1228	991	1408 (1)	1251 (4)	1493 (1)(4)
Border girder	1382	962	1434 (2)	1427 (6)	1460 (1)(4)
Damaged girder	1382	721	1428 (3)	1406 (7)	1484 (1)(5)

Table 8: Load combinations for the ULS verifications

- (1) GFRP: H = 150 mm, webs in the transverse direction;
- (2) GFRP: H = 200 mm, webs in the transverse direction;
- (3) GFRP: H = 350 mm, webs in the transverse direction;
- (4) CFRP: No. 1 laminates 80 mm x 1.4 mm;
- (5) CFRP: No. 2 laminates 80 mm x 1.4 mm;
- (6) CFRP: No. 3 laminates 80 mm x 1.4 mm;
- (7) CFRP: No. 4 laminates 80 mm x 1.4 mm.

4 CONCLUSIONS

We have presented the innovative solution developed within the European project SURE-Bridge for the refurbishment of road bridges. The proposed technique applies to bridges with reinforced concrete slab and longitudinal girders made of either reinforced concrete or steel. Longitudinal girders are strengthened by bonding pre-stressed CFRP laminates to their bottom surfaces. GFRP panels are connected to the deck to increase its overall bending strength and to widen the road section, if necessary.

A mechanical model has been developed to evaluate the ULS bending moment of strengthened cross sections and implemented into an *ad hoc* software tool. The results from this simplified model have been validated against the results of non-linear finite element analyses of suitably chosen prototype beams. Experimental testing of the same prototype beams is currently (July 2017) in progress.

Application for the strengthening and widening of the San Miniato bridge case study has demonstrated the feasibility and effectiveness of the proposed technical solution.

ACKNOWLEDGEMENTS

Financial support from the ERA-NET Plus Infravation 2014 Call within the SUREBridge Project is gratefully acknowledged.

REFERENCES

- [1] SUREBridge – Sustainable Refurbishment of Existing Bridges, <http://surebridge.eu/> (accessed 1 July 2017).
- [2] FiberCore Europe, <http://www.fibercore-europe.com> (accessed 1 July 2017).
- [3] R. Haghani, M. Al-Emrani, R. Kliger, A new method for strengthening concrete structures using prestressed FRP laminates. *8th International Structural Engineering and Construction Conference (ISEC 2015)*, Sydney, Australia, November 23–28, 2015.
- [4] EN 1992-1-1:2004, *Eurocode 2 – Design of concrete structures – Part 1-1: General rules and rules for buildings*.
- [5] SUREBridge – Sustainable Refurbishment of Existing Bridges, *Deliverable D4.2 – Design model for innovative FRP refurbishment of concrete deck bridges*, 2017.
- [6] *Strand7 Software Theoretical Manual – Theoretical background to the Straus7 finite element analysis system, 1st Edition*. Strand7 Pty Limited, 2005.
- [7] E.C. Chan, *Nonlinear geometric, material and time-dependent analysis of reinforced concrete shells with edge beams*. PhD Thesis, University of California, Berkeley, 1982.
- [8] E. Spacone, V. Ciampi, F.C. Filippou, Mixed formulation of nonlinear beam finite element. *Computers & Structures*, 1996.
- [9] E. Davini, *Un caso studio del progetto europeo SUREBridge: il ponte sul fiume Elsa in località Isola di San Miniato*. MSc Thesis, University of Pisa, Pisa, 2016.
- [10] Circolare Min. LL.PP. del 23 gennaio 1965, n. 1398, *Norme per l'impiego delle strutture in cemento armato precompresso*.
- [11] Circolare del Consiglio Superiore del Ministero dei LL.PP. del 14 febbraio 1962, n. 384, *Norma relativa ai carichi per il calcolo dei ponti stradali*.
- [12] D.M. Infrastrutture del 14 gennaio 2008, *Nuove norme tecniche per le costruzioni*.

- [13] D.M. Infrastrutture e Trasporti del 5 novembre 2001, n. 6792, *Norme funzionali e geometriche per la costruzione delle strade*.
- [14] CNR-DT 200 R1/2013, *Istruzioni per la Progettazione, l'Esecuzione ed il Controllo di Interventi di Consolidamento Statico mediante l'utilizzo di Compositi Fibrorinforzati*, Consiglio Nazionale delle Ricerche.