

RECEIVED
MAR 10 1964
RECEPTION NUMBER
10334
CLASS
CODE
26
CATEGORY

DEPARTMENT OF PHYSICS
University of Southern California
Los Angeles 7, California

Department of Physics
University of Southern California
Los Angeles 7, California

Semi-Annual Status Reports
No. 1, 2, and 3
for the
18 month period ending 28 February, 1963
on

VACUUM ULTRAVIOLET RADIATION
AND SOLID STATE PHYSICS

sponsored by the
National Aeronautics and
Space Administration

MAR 27 1963

Grant No. NsG-178-61

submitted by
G. L. Weissler
Chief Investigator

March 15, 1963

"Vacuum Ultraviolet Radiation and
Solid State Physics"

Department of Physics
University of Southern California
Los Angeles 7, California

Since this report covers an 18-month period, up to and including February 28, 1963, the material presented here may be regarded as intermediary between the normal type of brief status report and a technical report.

This NASA grant concerns itself primarily with vacuum ultraviolet radiation and its interactions with solid materials, and the various activities initiated under the auspices of this grant will be described under separate headings.

1. Vacuum UV Photon Interactions with Surfaces Kept in an Ultra-High Vacuum

An ultra-high vacuum system, as shown in Fig. 1, has been designed, built, and put into preliminary operation. After the first bake-out a vacuum of 4×10^{-9} mm Hg has been obtained. Several modifications have been made in the vacuum manifold, which is now being readied for final assembly. Aside from the commercially purchased pumps the bakable vacuum system consists entirely of stainless steel. Various sections are shown which are made vacuum tight by special copper gasket seals. Two bakable liquid nitrogen traps with oil-creep barriers and radiation

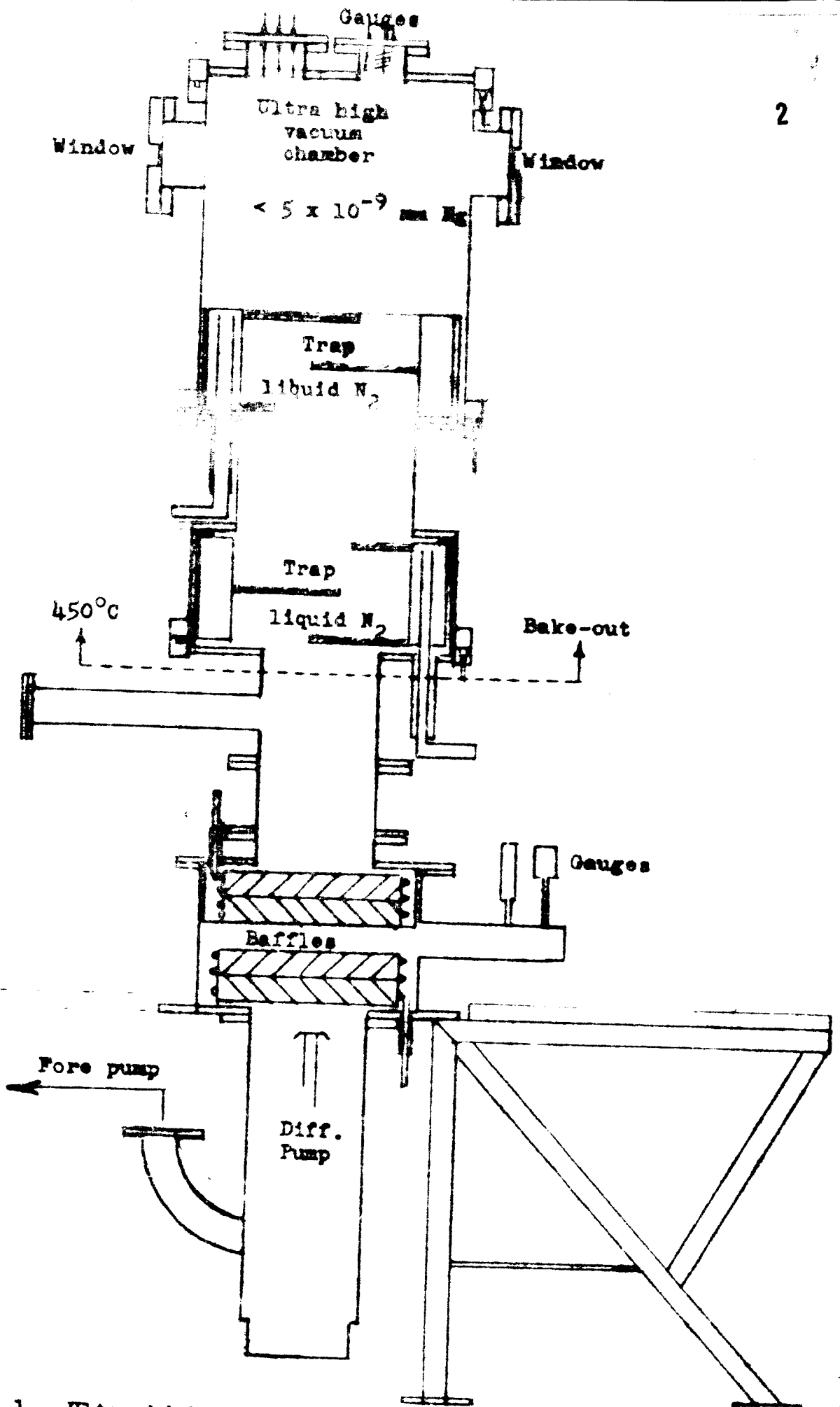

Fig. 1. Ultra high vacuum system for reflectivity measurements on ultra clean evaporated films (side view).

shields have been incorporated in this design, keeping in all essentials to the most advanced ideas from the Livermore Radiation Laboratory and from the Princeton Stellarator project.

At the present time, the uppermost experiment chamber is provided with four sapphire windows which transmit radiation from the infra-red down to 1500 Angstrom units. Initial experiments are planned on barium, which will be evaporated under ultra-high vacuum conditions, of the order of 10^{-10} mm Hg. The reflectivity of this surface will then be studied as a function of wavelength down to 1500 Angstrom units and for 2 angles of incidence. A literature search has indicated that pronounced changes in the reflectivity are to be expected in the short wavelength region. These reflectivity data will clarify the variation of the optical constants, namely the index of refraction, n , and the extinction coefficient, k , which will be calculated with computer help from the Kramers-Krönig dispersion relation. It is anticipated that interesting new results will be obtained. These results should be characteristic of barium only and not of contaminations, such as oxides, carbonates, etc., which are unavoidable under conditions of ordinary high vacua, of the order of 10^{-5} to 10^{-6} mm Hg.

Fig. 2 shows a plan view of the ultra-high vacuum

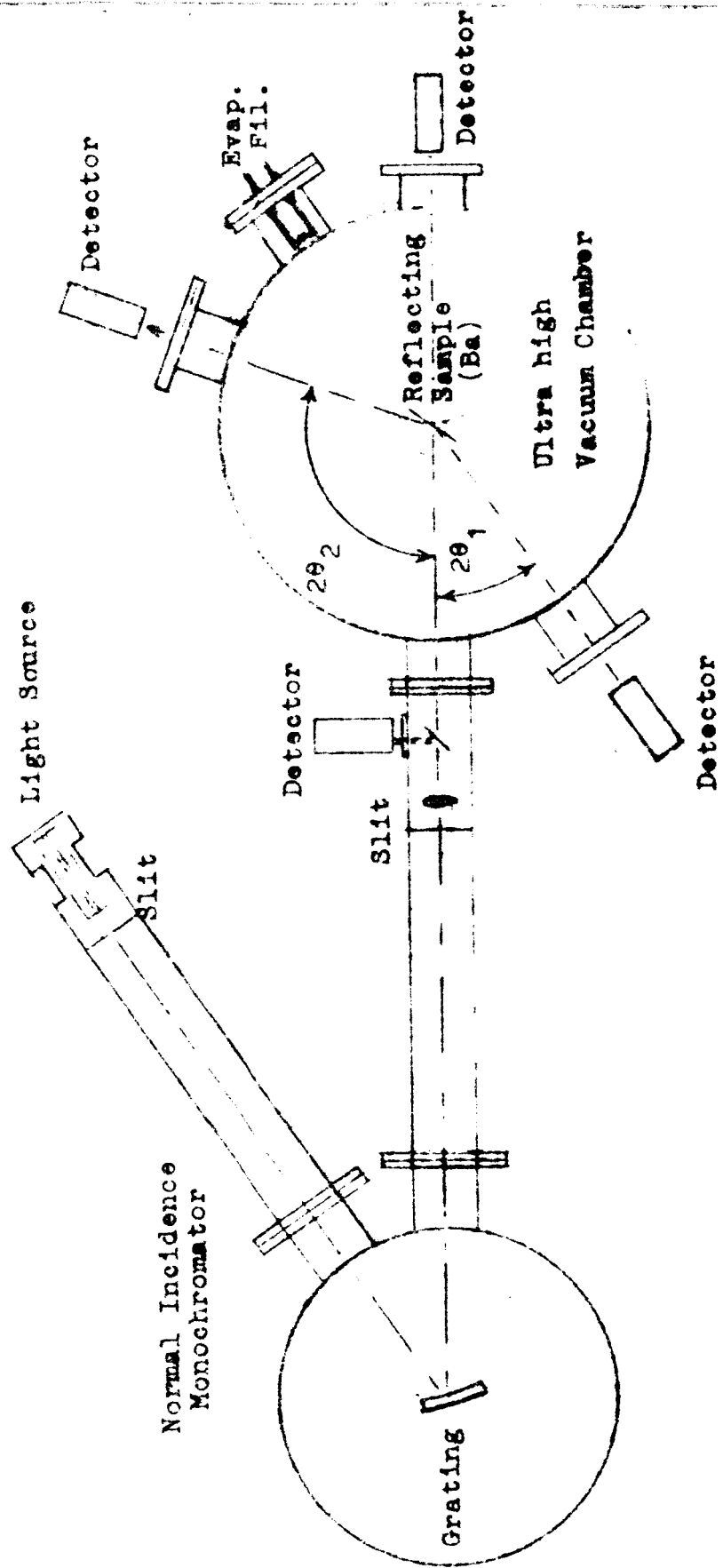

Fig. 2. Plan view of ultra high vacuum system (on the right) used in conjunction with a normal incidence monochromator (on the left) for reflectivity measurements at two angles, θ_1 and θ_2 .

system containing a sample of barium. The monochromator is shown on the left of the figure and provides beyond its exit slit monochromatic radiation from the near infrared down to 1500 Angstrom units. The two angles at which reflectivity measurements will be undertaken are shown in this figure.

All of this equipment shown in Figs. 1 and 2 has been designed and built by the USC Physics Shop. The ultra-high vacuum system is ready for final operation and the monochromator associated with it (as shown in Fig. 2) is nearly finished and should be assembled in approximately one month from the time of this writing.

Future extension of this work will be to study the optical constants of a variety of materials, all under conditions of ultra-high vacua, and eventually to decrease the wavelength range down to approximately 500 Angstrom units.

2. Plasmon Radiation Excited in Thin Films by 50 KV Electrons

When electrons of high energy pass through thin films, theory predicts that certain characteristic energy losses will be suffered by these electrons which are equal to the plasma frequency. This plasma frequency lies in the range of between 5 and 50 electron volts, depending on film material, etc. If an electron stream excites such a plasma to its characteristic oscillations, it is

also predicted that the plasma will re-radiate photons in energy equal to the equivalent plasma frequency. For most metals this plasmon re-radiation lies in the wavelength range of the vacuum ultraviolet. In order to observe this type of radiation, the apparatus described in Fig. 3 has been designed, built, and is nearing completion. Electrons from a filament at ground potential (lower left of Fig. 3) are accelerated towards a thin film deposited on a target holder, which is maintained at +50 KV. The impact point of the electrons on the target is equivalent to the position of a primary slit of a vacuum spectrograph (upper portion of Fig. 3). Plasmon radiation, which is excited by the electron beam impinging on the thin target film, will travel towards the grating of the vacuum spectrograph. From the grating it will be dispersed and registered on a photographic film as indicated in Fig. 3. This photographic film will cover a wavelength range from 4000 Angstrom units down to approximately 400 Angstrom units, a region which should contain the plasmon wavelengths of a wide variety of materials. It is hoped that this experiment will be ready for first trial runs within one or two months.

3. Light Source and Detector Development of Vacuum UV Radiation

A versatile new vacuum monochromator has been built which can be operated in two modes: as a Seya monochromator, shown in Fig. 4, and as a grazing incidence spectrograph, shown in Fig. 5.

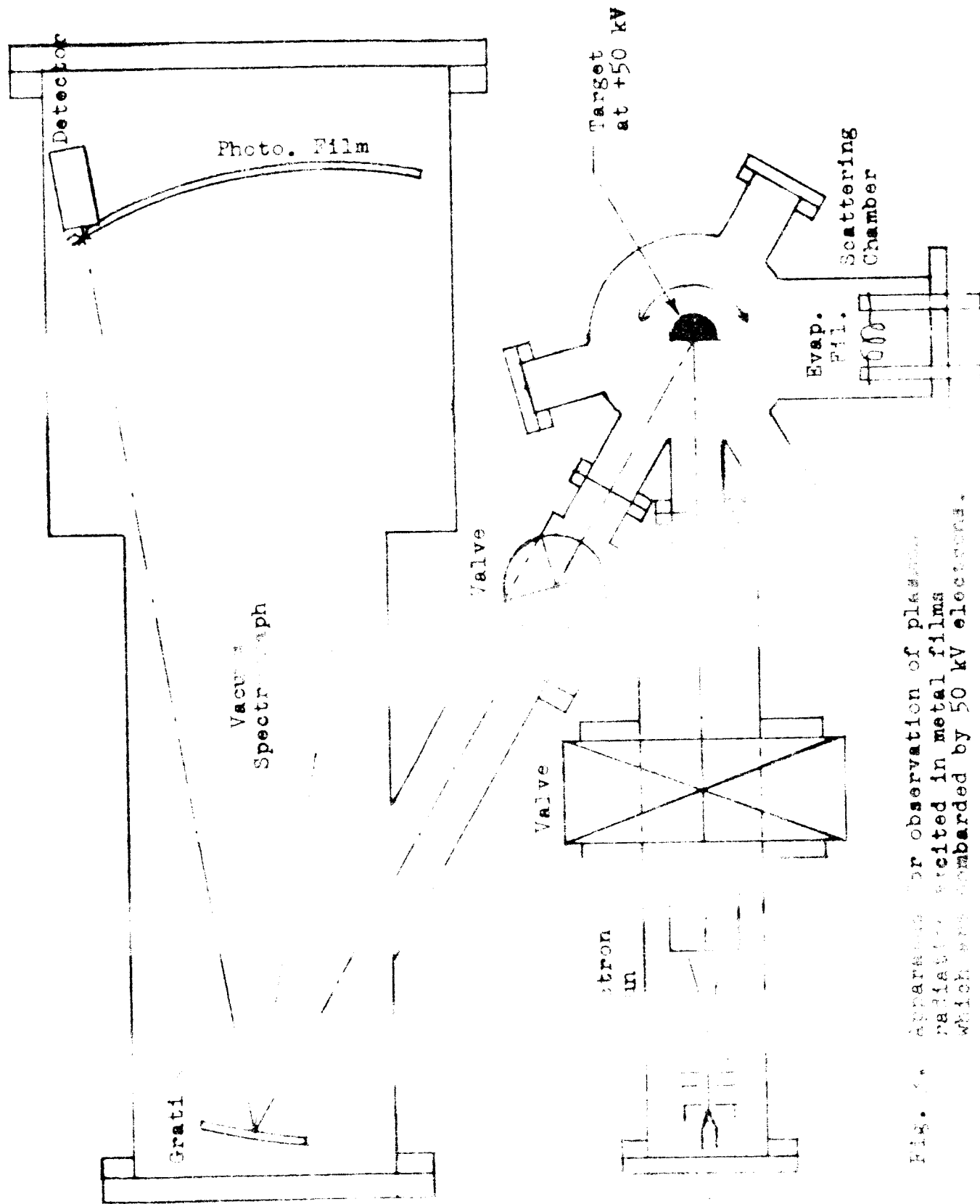
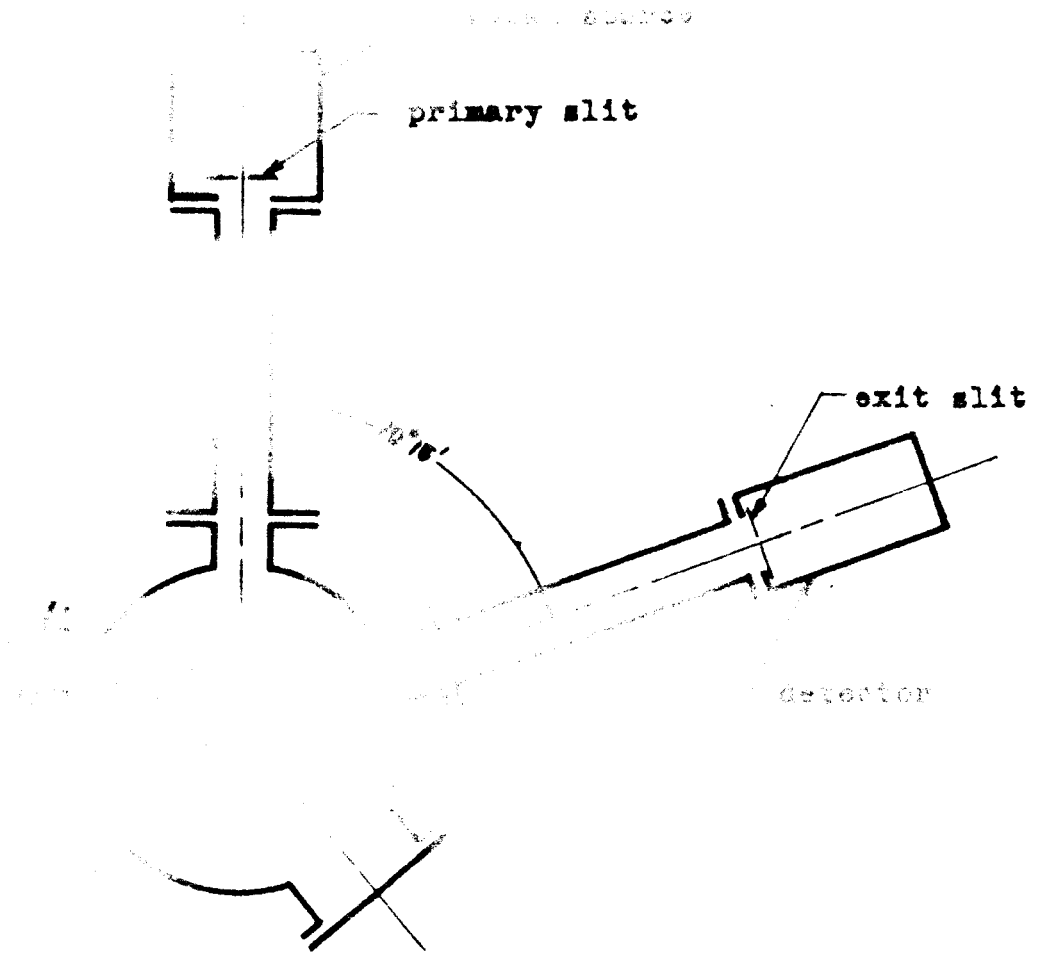

Fig. 1. Apparatus for observation of plasmas. Radiation excited in metal films which are bombarded by 50 kV electrons.

Fig. 1



... ..
... ..
... ..

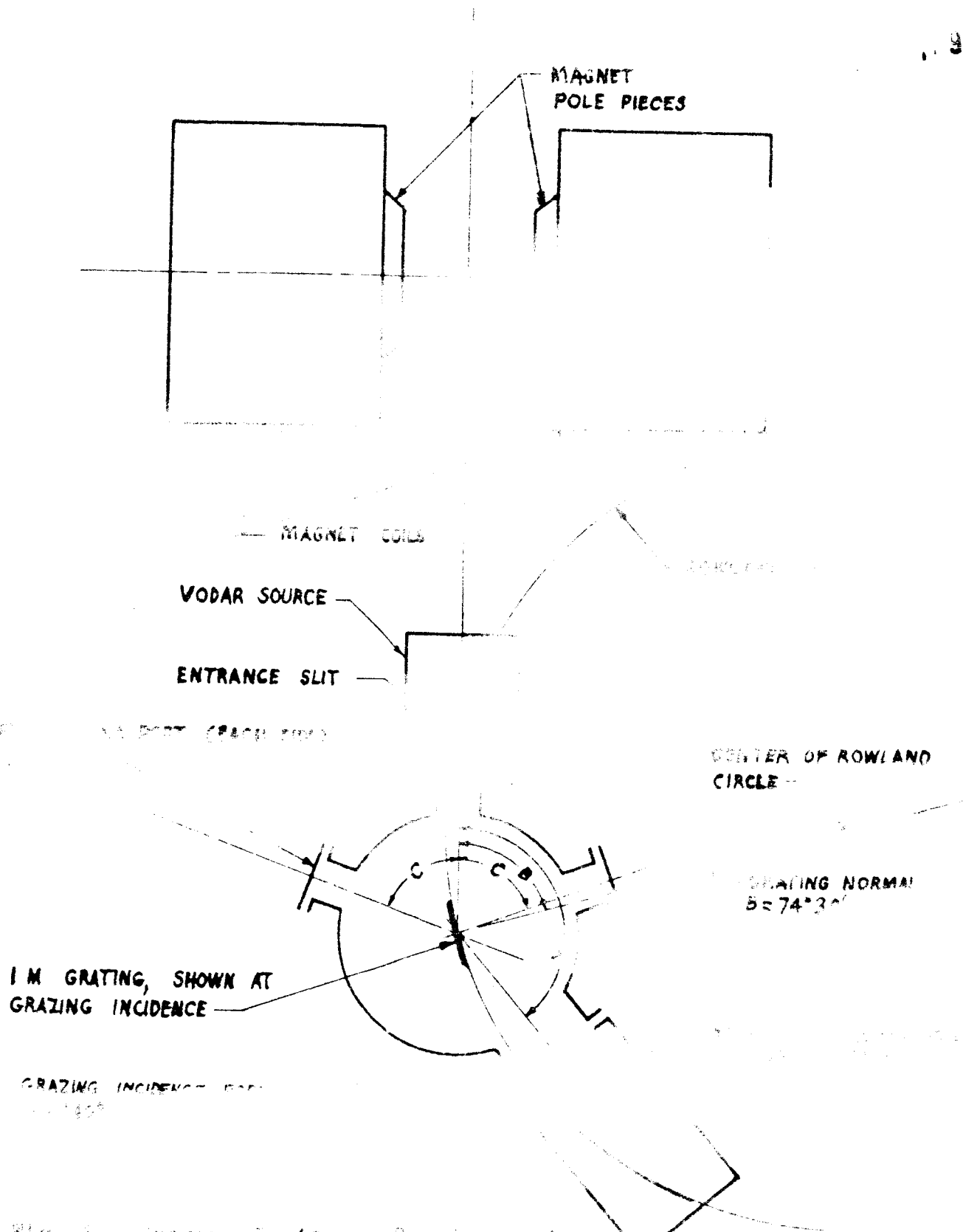

Fig. 3. Grazing Incidence Spectrograph and Monochromator designed for two purposes:

- light source development at shorter wavelengths (100 to 500Å), and
- Zeeman effect splitting of spectral lines in the vacuum ultraviolet with subsequent

The Seya mounting covers a wavelength region from 12,000 to 500 Angstrom units, with a reciprocal linear dispersion of 17 Angstroms per mm. In contrast, the grazing incidence mounting covers a much shorter and narrower wavelength region, from 500 to 150 Angstrom units, with a much higher reciprocal linear dispersion, of the order of 3 Angstroms per mm. This instrument will be used in both modes to test new ideas with respect to high intensity light sources in this general spectral region and to develop new types of detectors, capable of counting absolute numbers of photons leaving the exit slit.

This work is now actively under way, and it is hoped to produce either a technical report or a contributed paper to a scientific meeting or both during 1963.

Beyond source and detector development work, this instrument will also be used to look for vacuum ultraviolet polarization effects. This will be accomplished in two independent ways:

- a) by looking for the vectorial effect in the emission of photo-electrons, and
- b) by looking for Zeemann components when the light source is placed in a strong magnetic field (a 12-inch electromagnet capable of 30,000 gauss is indicated in Fig. 5).

4. Photo-Electric Yields, Transmissivities, and Reflectivities at Grazing Incidence

Dr. B. Vodar of the Centre National de la Recherche Scientifique in Bellevue (near Paris) has designed a grazing incidence monochromator, which covers the wavelength region from 1000 to 100 Angstrom units. The characteristic feature of this instrument is that in the scanning process the exit slit remains fixed, while both the grating as well as the primary slit (to which the light source is attached) move along straight lines. For our purposes this appeared to be an exceptionally useful instrument. For this reason a purchase order was placed with Dr. Vodar and the instrument was received in the fall of 1962. At the present time a vacuum system is fitted to it and a detector, to be placed behind the exit slit, is being constructed. A grating, lightly ruled on glass, has been specially made for the instrument and will be installed during the next few weeks. It is anticipated that this grazing incidence monochromator will be focused and operational by early summer, 1963.

The principle purpose of this instrument is to study reflectivities of surfaces in the extreme ultraviolet, where very little information is available at this time. Specifically, it is hoped to determine grating efficiencies in this wavelength region and to check by direct measurement to what extent calculated blaze angles really provide

enhancement of intensities at the predicted short wavelengths. A program of routinely checking such grating efficiencies is now being set-up.

In addition, it is planned to study the transmission properties of thin films, of the order of 500 to 1500 Angstrom units thick, of such materials as aluminum, indium, tellurium, zinc, and others. Earlier researches at this laboratory have shown pronounced light transmission in the region below 1000 Angstrom units. It is essential that these transmission properties be determined at wavelengths shorter than 500.

Finally, this instrument is also designed for the determination of photo-electric yields from various surfaces. A considerable gap exists between our data taken at longer wavelengths and those from Russian investigators obtained in the soft X-ray region. It is hoped that these experiments will bridge this gap.

In order to accomplish these various researches, a single, multi-purpose target chamber has been designed and is shown, together with the Vodar monochromator, in a side view in Fig. 6 and in a plan view in Fig. 7. Most of the vacuum system shown in Fig. 6 has been built. However, the target chamber itself is still in the design stages and will not be ready for the machine shop until later in the spring of 1963.

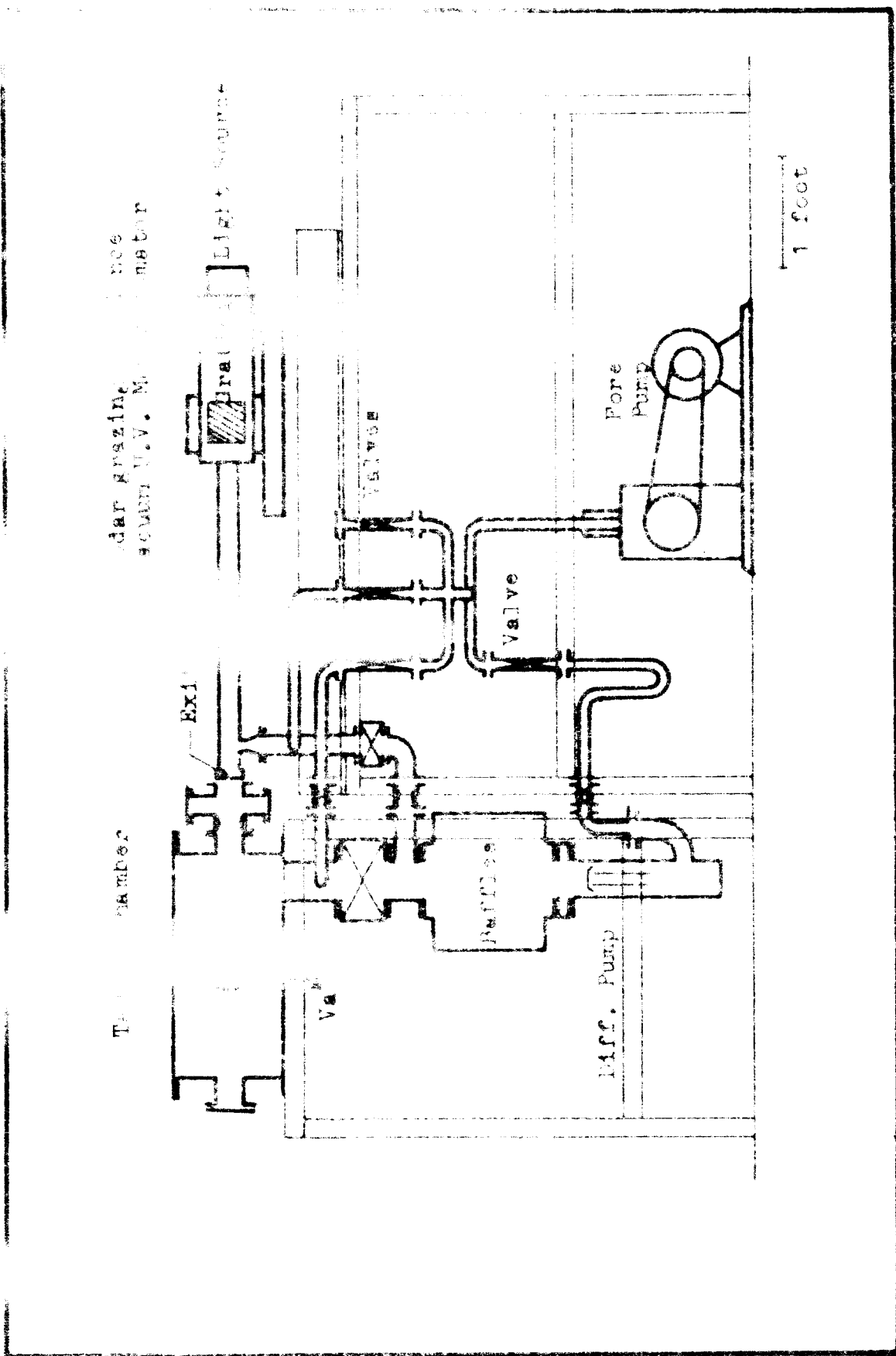

Fig. 5. Side view of the Vodar grazing incidence monochromator used in conjunction with transmission, reflectivity, and photo-yield measurements in a target chamber.

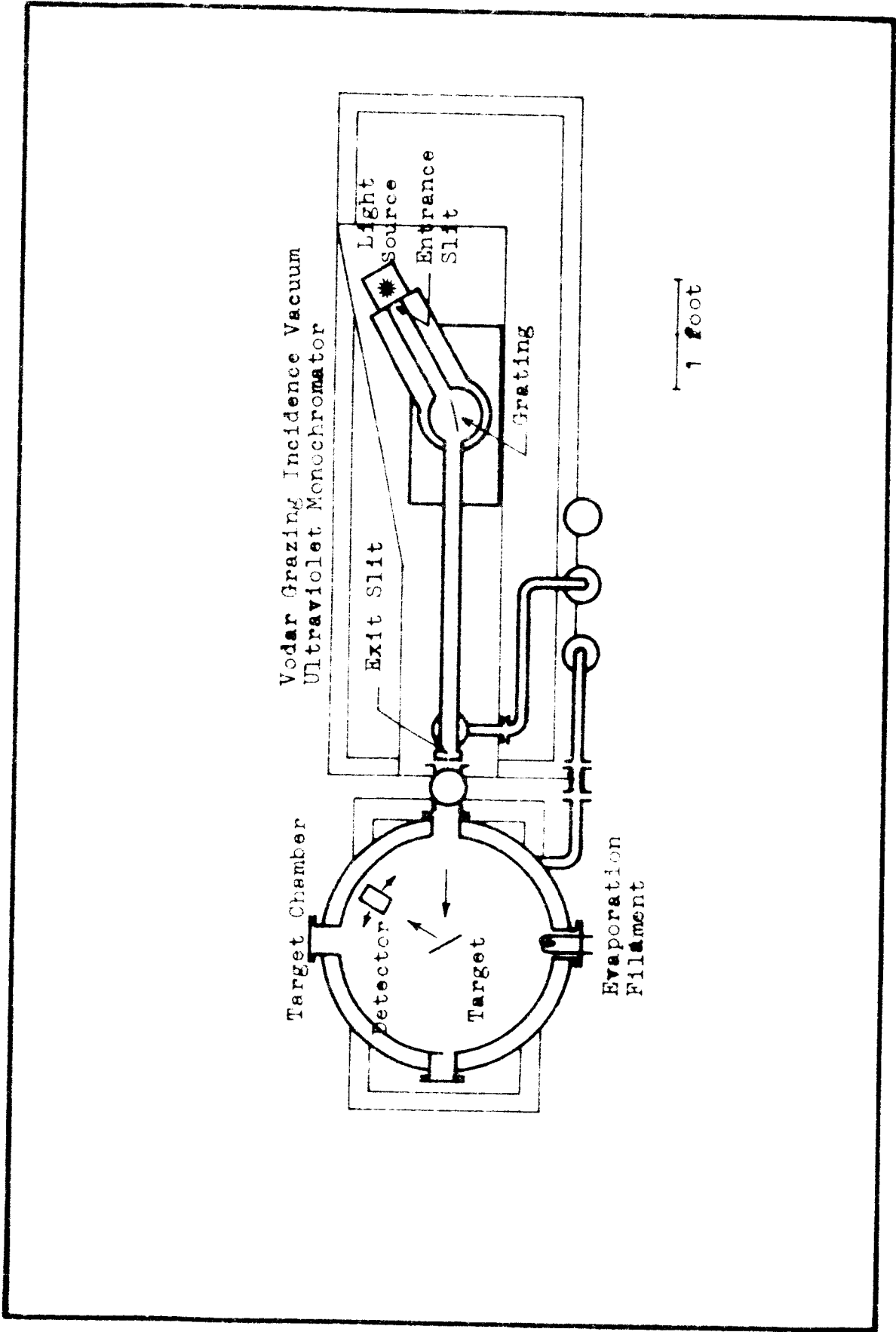

Fig. 7. Plan view of Vodar monochromator and target chamber for transmission, reflectivity, and photo-yield measurements.

5. Summary

During the 18-month period of these three status reports, a considerable variety of research and development projects have been initiated as indicated by the material presented above. It is felt that a number of interesting research results will be forthcoming during the course of this year. These will be distributed either in the usual form of technical reports or in the form of reprints of published notes and articles.

25 copies respectfully submitted, -



G. L. Weissler
Professor of Physics
Chief Investigator
NASA Grant No. NsG-178-61

March 15, 1963