

# UNPUBLISHED PRELIMINARY DATA

SEMI-ANNUAL STATUS REPORT - NASA RESEARCH GRANT Nsg-327 - April 1, 1965 .

## VIDEOROENTGENOGRAPHIC STUDY OF THE HEART AND LUNGS DURING EXPOSURE TO FORWARD ACCELERATION

I. Summary of results of investigations on the Mayo Centrifuge carried out since January 1962 which have been supported in part by NASA.

(a) Results of investigations supported by NASA Interagency Transfer Fund R-43 (contract period, December 1961 to December 1964) are reported in relatively complete form in the twelve quarterly progress reports submitted to the Air Force contract officer with copies to NASA during the three-year contract period and in the final WADD Technical Reports listed below:

1. Wood, E. H., Sutterer, W. F., Marshall, H. W. and Nolan, A. C.: Use of the Human Centrifuge to Study Circulatory, Respiratory and Neurologic Physiology in Normal Human Beings and a Description of an Electronic Data Processing System Designed to Facilitate These Studies. WADD Technical Report 63-105 (December) 1963.
2. Wood, E. H., Nolan, A. C., Donald, D. E., Edmundowicz, A. C. and Marshall, H. W.: Technics for Measurement of Intrapleural and Pericardial Pressures in Dogs Studied Without Thoracotomy and Methods for Their Application to Study of Intrathoracic Pressure Relationships During Exposure to Forward Acceleration (+G<sub>x</sub>). WADD Technical Report 63-107 (December) 1963.
3. Reed, J. H., Jr. and Wood, E. H.: Use of Dichromatic Earpiece Densitometry for Determination of Cardiac Output. WADD Technical Report (November) 1964 (in press).
4. Banchemo, N., Cronin, L., Nolan, A. C. and Wood, E. H.: Blood Oxygen Changes Induced by Forward (+G<sub>x</sub>) Acceleration. WADD Technical Report (November) 1964 (in press).

(b) Results of investigations supported by NASA Research Grant Nsg-327 (funded grant period October 1, 1962 to October 1, 1964 - unfunded period October 1, 1964 to present) are summarized in the four semi-annual status reports which were submitted on April 1 and October 1, 1963 and April 1 and October 1, 1964.

There are also a number of manuscripts which are published or in the process of publication reporting results of these investigations. These are listed below:

1. Wood, E. H., Nolan, A. C. and Donald, D. E.: Effect of Forward Acceleration on Circulatory, Pleural and Related Pressures. Aerospace Medicine 34:270 (March) 1963.
2. Edmundowicz, A. C. (Wood, E. H.): Intrathoracic Pressure Relationships in Dogs Without Thoracotomy. Federation Proceedings 22:459 (March-April) 1963.

FACILITY FORM 602

N65-21324

(ACCESSION NUMBER)

23

(THRU)

04

(CODE)

CR 67958

(CATEGORY)

(PAGES)

(NASA CR OR TMX OR AD NUMBER)

Hard copy (HC) \$1.00

Microfiche (MF) \$0.50

3. Kenner, H. M. and Wood, E. H.: Pericardial, Intrapleural and Intracardiac Pressures During Acute Heart Failure in Dogs Without Thoracotomy. Federation Proceedings 22:459 (March-April) 1963.
4. Nolan, A. C., Marshall, H. W., Cronin, L., Sutterer, W. F. and Wood, E. H.: Decreases in Arterial Oxygen Saturation and Associated Changes in Pressures and Roentgenographic Appearance of the Thorax During Forward (+G<sub>x</sub>) Acceleration. Aerospace Medicine 34:798-813 (September) 1963.
5. Wood, E. H., Nolan, A. C., Donald, D. E. and Cronin, L.: Influence of Acceleration on Pulmonary Physiology. Federation Proceedings 22:1024-1034 (July-August) 1963.
6. Banchemo, N., Cronin, L., Nolan, A. C. and Wood, E. H.: Blood Oxygen Changes Induced by Forward (+G<sub>x</sub>) Acceleration. Aerospace Medicine 35:257-258 (March) 1964.
7. Sturm, R. E., Sanders, J. J. and Wood, E. H.: A Roentgen Videodensitometer for Circulatory Studies. Federation Proceedings 23:303 (March-April) 1964.
8. Banchemo, N., Rutishauser, W., Tsakiris, A. G. and Wood, E. H.: Respiratory Pleural Pressure Amplitude in Dogs Studied Without Thoracotomy. The Physiologist 7:85 (August) 1964.
9. Rutishauser, W., Banchemo, N., Tsakiris, A. G. and Wood, E. H.: Pleural Pressures in Dogs in Supine and Prone Body Positions Studied Without Thoracotomy. The Physiologist 7:241 (August) 1964.
10. Reed, J. H., Jr. and Wood, E. H.: Use of Dichromatic Earpiece Densitometry for Determination of Cardiac Output. The Physiologist 7:234 (August) 1964.
11. Mook, G. A., Osypka, P., Sturm, R. E. and Wood, E. H.: Fiber-Optic Densitometry on Blood. The Physiologist 7:208 (August) 1964.
12. Wood, E. H., Sturm, R. E. and Sanders, J. J.: Data Processing in Cardiovascular Physiology with Particular Reference to Roentgen Videodensitometry. Mayo Clinic Proceedings 39:849-865 (November) 1964.
13. Sanders, J. J.: Data Extraction From a Video Display. IBM GPD Development Laboratory, Rochester, Minnesota TR 07.036 (April) 1964.
14. Marsden, M. J.: Design of Filters for Use on Discrete Data. IBM GPD Development Laboratory, Rochester, Minnesota TR 07.06.061.032, February 28, 1964.
15. Rutishauser, W., Banchemo, N., Tsakiris, A. G., Sturm, R. E. and Wood, E. H.: Pleural Pressures in Dogs During Transverse Acceleration. Aerospace Medicine 26:161 (February) 1965.

16. Banchemo, N., Rutishauser, W., Tsakiris, A. G., Sturm, R. E. and Wood, E. H.: The Effect of Forward, Backward, Right Lateral and Left Lateral Acceleration on Blood Oxygen Saturation in Dogs. *Aerospace Medicine* 26:136 (February) 1965.
17. Rutishauser, W. J. and Fowler, W. S. (Wood, E. H.): Pleural and Esophageal Pressures During Transverse Acceleration in Different Body Positions. *Federation Proceedings* 24:644 (March-April) 1965.
18. Banchemo, N. and Monge, C. (Wood, E. H.): Pericardial Pressures in Different Body Positions During Transverse Acceleration in Dogs Studied Without Thoracotomy. *Federation Proceedings* 24:644 (March-April) 1965.
19. Rutishauser, W. J., Banchemo, N., Tsakiris, A. G., Edmundowicz, A. and Wood, E. H.: Pleural Pressures at Dorsal and Ventral Sites in Supine and Prone Body Positions. *Journal of Applied Physiology* (in press).
20. Banchemo, N., Cronin, L., Nolan, A. C. and Wood, E. H.: Blood Oxygen Changes Induced by Forward (+G<sub>x</sub>) Acceleration. *Aerospace Medicine* (in press).
21. Reed, J. H., Jr. and Wood, E. H.: Use of Dichromatic Earpiece Densitometry for Determination of Cardiac Output. *Journal of Applied Physiology* (in press).
22. Anderson, R. P., Sturm, R. E. and Wood, E. H.: An Active Low-Pass Filter for Biomedical Applications. *Journal of Applied Physiology* (in press).
23. Sanders, J. J.: Data Extraction From a Video Display. *IEEE Transactions on Biomedical Engineering* (in press).

The roentgen videodensitometer, support for development of which was in large part from research grant NASA Nsg-327, has made possible a number of studies of factors affecting mitral valve function which have considerable significance in circulatory physiology as well as in clinical cardiology and cardiovascular surgery. These are listed below:

1. Williams, J. C. P., O'Donovan, T. P. B., Sturm, R. E. and Wood, E. H.: Roentgen Videodensitometric Study of Efficacy of Mitral Valve Closure in Dogs Without Thoracotomy. *The Physiologist* 7:287 (August) 1964.
2. O'Donovan, T. P. B., Williams, J. C. P. and Wood, E. H.: Effect of Vagal Stimulation on Atrial Transport Studied in Dogs Without Thoracotomy. *The Physiologist* 7:218 (August) 1964.
3. Williams, J. C. P., O'Donovan, T. P. B., Vandenberg, R. A., Osypka, P., Sturm, R. E. and Wood, E. H.: Roentgen Videodensitometer Study of the Efficacy of Mitral Valve Closure During Electronically Controlled Cardiac Arrhythmias. *Journal of Laboratory and Clinical Medicine* 64: 1018 (December) 1964.

4. Vandenberg, R. A., Sturm, R. E. and Wood, E. H.: Efficiency of Closure of the Mitral Valve by Isolated Ventricular Systoles. Federation Proceedings 24:704 (March-April) 1965.
5. Williams, J. C. P., O'Donovan, T. P. B., Osypka, P. and Lambert, E. H. (Wood, E. H.): Efficacy of Atriogenic Closure of Mitral Valve in Dogs Without Thoracotomy. Federation Proceedings 24: 704 (March-April) 1965.
6. Tsakiris, A. G. and Burchell, H. B. (Wood, E. H.): Effects of Acute Cardiac Denervation on Cardiac Performance in Dogs Studied Without Thoracotomy. Federation Proceedings 24:705 (March-April) 1965.

(c) In summary, some of the results and accomplishments of investigative projects supported in part by NASA funds which have been carried out on or in conjunction with the human centrifuge of the Mayo Clinic and Mayo Graduate School of Medicine during the period January 1962 to the present are as follows:

1. Development of technics for continuous, simultaneous measurement of pleural pressures at multiple sites in the thorax of dogs studied without thoracotomy.
2. Development of a technic for continuous recording of pericardial pressure in dogs studied without thoracotomy.
3. Development of methods for applying these technics during exposure to acceleration on the centrifuge along with previously developed technics for continuous and simultaneous registration of right and left atrial, ventricular, aortic, pulmonary airway, and esophageal pressures in dogs studied without thoracotomy along with the operating parameters of the centrifuge (i.e., RPM, acceleration, angle of tilt of cockpit).
4. Modification and installation of a roentgen fluoroscopic image-intensifier, image-orthicon video assembly in a specially designed and fabricated cockpit which allows roentgenographic studies at any desired angle through the thorax during acceleration.
5. Development of methods for remote control of this roentgenographic assembly and for transmission of the video signal from the centrifuge cockpit to a remotely located videotape recorder.
6. Development of a roentgen videodensitometer for quantitative measurements (60/second) of the roentgen opacity of any selected area of variable size (0.25 to 100 cm.<sup>2</sup>) in the roentgen silhouette of the heart and lungs or other bodily structures.

7. Development of specially fabricated half-body plastic casts to provide: Body support and accurate control of body position of dogs without interference with roentgenographic studies of the heart and lungs during acceleration.
8. Development of technics based on biplane roentgenograms for accurate localization of the positions of catheter tips during centrifuge rotation along with zero reference level corrections of multiple catheter-manometer systems to any desired level in the thorax.
9. Development of analog-to-digital and digital-to-analog electronic data-processing technics and digital computer programs for:
  - (a) Performing base-line correction calculations for multiple catheter-manometer systems based on continuous recordings of centrifuge RPM and cockpit angle followed by computer controlled electronic digital-to-analog conversion and plotting of the corrected and equivalently scaled results.
  - (b) Calculation of the position of catheter tips in the thorax from measurements on biplane roentgenographic films.
  - (c) Correction of videoroentgenographic recordings of dilution curves of roentgen contrast media at any site in the cardiac or great vessel silhouette for non-specific changes due to changes in position and dimensions associated with the cardiac cycle.
  - (d) A digital technic for a highly effective (40 db/octave cut-off) low-band pass filter for removal of the relatively high frequency vibrational artifacts which frequently obscure recordings of intracardiac and vascular pressures obtained via cardiac catheter-manometer systems during centrifuge rotation.
10. Due to large amount of digital computer time and, hence, high expense of digital filtration of these data, a highly effective method for filtration of these data on a real-time basis has been developed using an analog computer. These analog computer filter assemblies can be made with any desired cut-off frequency and with an attenuation rate of 40 db/octave at the selected frequency.
11. Development of technics for remotely controlled injections of roentgen contrast medium or indicator dyes at desired sites in the circulatory system during periods of centrifuge rotation along with constant rate sampling of mixed arterial and venous blood for continuous registration of oxygen saturation or concentration of indicator dyes.
12. Modification of an RCA model TR2 videotape recorder to make possible simultaneous recording on the same magnetic tape with the videoimage

of: (a) the electrocardiogram (or any other physiologic variable), (b) a digital binary coded decimal signal for subsequent synchronization and electronic search and retrieval operations, and (c) the instant, amount and duration of injections of contrast medium. These modifications greatly simplify the problem of synchronization of recorded changes in the video image during the cardiac cycle with simultaneous changes of other hemodynamic parameters.

13. Development of technics for simultaneous photokymographic and magnetic tape recordings of up to 21 physiologic variables along with the videotape recordings mentioned in item 12.
  14. The technics listed above along with others have been used to carry out the studies reported in the Air Force technical reports, NASA technical reports and the published reports listed above.
- (d) These studies have demonstrated that levels of acceleration similar to those encountered in the launch and re-entry phases of space flight cause:
1. Severe degrees of arterial hypoxemia in healthy human subjects or anesthetized dogs apparently due to development of large pulmonary arterial venous shunts.
  2. Highly positive intrapleural pressures in the dependent regions of the thorax which would be expected to cause extensive pulmonary atelectasis during periods of acceleration.
  3. Highly negative intrapleural pressures in the superior regions of the thorax which may attain levels sufficient to cause rupture of pulmonary parenchyma during such exposures.
  4. These changes occur at different sites in the thorax but are of similar magnitude during plus and minus  $G_x$  and  $G_y$  acceleration and during plus  $G_x$  acceleration when the body is tilted 15 degrees head-up or head-down.
  5. There are striking changes in esophageal and pericardial pressures depending on the direction of the acceleration and the vertical height of the recording site in the thorax.
  6. Transmural right and left atrial pressures and transpericardial pressures in anesthetized dogs are not greatly changed in the acceleration range of from -6.5 to +6.5  $G_x$  or  $G_y$  acceleration.
  7. Interpolation between the values obtained during plus and minus  $G_x$  and  $G_y$  acceleration allows estimation of pleural and other intrathoracic pressures which would be expected to pertain at zero-G. Values for end-expiratory pleural pressure at zero-G ranged from -6 to -4 cm.  $H_2O$  and, as would be expected, were independent of body position and the sites in the thorax from which the pressures were recorded. Analogous esophageal pressures

at zero-G were about -3 cm. H<sub>2</sub>O which supports the finding that estimated pleural pressures corrected to the same vertical height as the esophageal catheter tip were 2 to 3 cm. H<sub>2</sub>O more negative than the esophageal pressure.

Estimated values for right and left atrial transmural pressures at zero-G were about 3 and 5 cm. H<sub>2</sub>O, respectively, while trans-pericardial pressures were not significantly different from zero.

8. The estimated hydrostatic indifference level (i.e., the reference level in the thorax at which recorded pressures did not vary with the level of plus and minus G<sub>x</sub> accelerations) was approximately at mid-lung level for right and left atrial pressures. The analogous values for pleural pressures was between 2 and 4 cm. ventral to mid-lung level.
9. At levels of G<sub>x</sub> and G<sub>y</sub> acceleration of 4G and above, vascular pressures at the arterial and venous ends of the pulmonary capillaries in the dependent regions of the thorax are far in excess of the colloidal osmotic pressure of plasma so that rapid development of pulmonary edema would be expected to occur in the dependent segments of the lung.
10. Concomitantly pulmonary artery pressure in the most superior regions of the lung approaches or falls to zero while (if collapse of the pulmonary veins does not occur in these areas) highly negative values occur at the venous end of the capillaries in these segments of lungs.

## II. The relationship of these results to space flight.

The only patho-physiologic effects of forward (+G<sub>x</sub>) acceleration which apparently pose a practically serious threat to the functional integrity of astronauts during the launch and re-entry phases of space flight arise from the large hydrostatic pressure imbalances which develop in the lungs and thorax.

These pressure imbalances occur in superior and dependent regions in the thorax at the interface (the alveolar membrane) between the alveolar-tracheal-bronchial tree (whose content, air, has a specific gravity of practically zero) and the pulmonary vascular tree (whose content, blood, has a specific gravity of about one). Due to this difference in specific gravity, the usual hydrostatic pressure differences which exist at interfaces of these air and blood containing compartments in superior and dependent regions of the lungs at 1G are multiplied during exposure to acceleration in direct proportion to the G level involved.

Pressure imbalances also develop in the potential intrapleural space which constitutes the interface between the relatively rigid chest wall and the visco-elastic lung parenchyma which separates these two compartments of widely different densities. The tendency of the fluid contents (air and blood, respectively) of the lungs to redistribute in

response to hydrostatic imbalances produced by the changes in weight associated with acceleration is relatively unrestricted and hence results in stresses on the lung parenchyma in proportion to the level of acceleration. These stresses caused by acceleration have been demonstrated to be capable of causing physical disruption of lung structures of primates including man. Furthermore, the disproportionate increase in the weight of the blood in relation to the air containing alveoli results in the collapse of these structures in the dependent portions of the lungs and their over-distention superiorly. Severe disturbances in ventilation-perfusion ratios develop in these regions of the lungs with absence of ventilation inferiorly so that a pulmonary arterial-venous shunt develops. This shunt is apparently responsible for the severe decreases in oxygen saturation of systemic arterial blood which have been observed under these circumstances.

In conclusion it is believed these results indicate that, exclusive of the danger of equipmental or instrumental malfunction, the cardiopulmonary effects of acceleration carry the greatest likelihood of causing a mission limiting or mission failure threat to the functional integrity or welfare of the astronauts. The possibility exists, which should be kept in mind by NASA biomedical personnel, that neglect of this problem may leave the nation's space program unnecessarily vulnerable to the occurrence of a real tragedy.

### III. Plans for future investigative activities.

The overall objectives of the staff of the Centrifuge Facility of the Mayo Clinic and Mayo Graduate School of Medicine are to further elucidate the mechanisms responsible for the cardiopulmonary effects of acceleration and, if possible, to develop technics to minimize these effects.

The current series of experiments being carried out on the centrifuge involves a study of the comparative effects of forward (+G<sub>x</sub>), backward (-G<sub>x</sub>), left-to-right (+G<sub>y</sub>) and right-to-left (-G<sub>y</sub>) acceleration on the oxygen saturation and hemoglobin content of arterial and mixed venous (pulmonary artery) blood, the degree of pulmonary arterial-venous shunting, hemoconcentration, intrapleural pressures, pericardial pressures and intrathoracic circulatory pressures and the roentgenographic appearance of the heart and lungs in dogs. Individually molded half-body casts fabricated for each of these four body positions for particular dogs are being used in these experiments. The casts are made from fiber glass and lucite using a whole-body plaster mold of the dog and are relatively non radio-opaque so that continuous roentgenographic studies of the dog's thorax can be carried out before, during and after each exposure.

The roentgen videodensitometer is being used in conjunction with indicator-dilution technics with simultaneous injections of the circulatory indicator (indocyanine green) and x-ray contrast media to study the blood content and circulation to the superior and dependent regions of the lung before, during and after exposure to acceleration in these various body positions.



This series of experiments is near completion and the analysis of the data obtained well underway. Preliminary results will form the basis for two presentations on the scientific programs of the spring meeting of the Aerospace Medical Association and two presentations on different phases of the results at the April 1965 meetings of the Federated Societies for Experimental Biology.

The next series of centrifuge experiments, which is currently in progress, will be specifically devoted to a roentgen videodensitometric study of the pulmonary circulation. Major alterations involving an improved design of the electronic components of the image-intensifier and videodensitometer assemblies are being completed prior to these studies.

It is hoped that these studies will provide information concerning some of the effects of  $G_x$  acceleration on the circulation to superior and dependent regions of the lungs at levels of acceleration ranging from  $-7$  to  $+7G_x$ . Pulmonary arterial and left atrial pressure will be recorded simultaneously along with determinations of total pulmonary blood flow (cardiac output) so that study of the inter-relationships of these parameters will be possible.

Initial results by roentgen videodensitometry indicate that blood flow to superior portions of the lungs is abolished at levels of acceleration of 6 to 7G while blood flow at mid-lung level (which atrial and pulmonary artery pressure studies indicate to be the hydrostatic indifference level of the pulmonary circulation) is essentially unchanged while concomitantly flow to the dependent regions of the lungs (where pleural pressures are highly positive so that atelectasis must be present) is greatly increased.

It is planned to combine these studies with radioactive tracer technics for regional pulmonary blood flow using tagged iodinated serum albumin aggregates and also tagged (radioactive and/or roentgen-opaque) microspheres of controlled densities and diameters. A comparison of the data obtained by simultaneous applications of these independent technics should allow critical evaluations of assumptions involved in the different methods and, therefore, make possible definitive estimates of the confidence limits of the results obtained.

If the request to NASA for funds to extend the physical capabilities of the centrifuge are approved, these studies will be carried to higher levels of acceleration and include the effect of oscillating the cockpit through an angle of up to  $\pm 60$  degrees from the resultant force vector at frequencies of up to 2 cycles/minute.

Subsequent projects contemplated for study include:

- (a) Repetition of the studies outlined above in primates selected to have thoracic dimensions and configurations as closely similar to those of adult humans as possible.

Up to the present only anesthetized dogs have been used in studies of intrapleural, intracardiac and pericardial pressures during acceleration. It has been found that the decreases in arterial oxygen saturation during acceleration found in large dogs are similar to those observed in healthy human subjects. It has been presumed that the dramatic increases to positive values of intrapleural pressure at dependent and concomitant highly

negative values at superior sites in the thorax were probably also somewhat similar in the two species. However, the configuration of the thorax of dogs and men is very different. Also and perhaps more important, the dorsal-ventral dimension of the lungs of an average adult human (about 20 cm.) is considerably larger than the average value of 12 cm. found in the dogs which have been studied. On the basis of hydrostatic considerations, it would not be surprising, therefore, if considerably greater pleural pressure differences between the superior and dependent surface of the lungs were produced in man than by equivalent levels of acceleration in dogs. Since measurement of pleural pressures is not considered to be of sufficient proven safety to be carried out on healthy human subjects on the centrifuge, it seems indicated to carry out such studies on experimental animals whose thoraces most closely simulate those of adult men.

- (b) Factors affecting ventilation and perfusion of pulmonary alveoli during hypergravitational stress.

In a co-operative study with Dr. C. Lenfant (Firland Sanatorium, Seattle, Washington), it is proposed to study the changes in the distribution of alveolar ventilation to perfusion ratios (VA/Q) throughout the lung occurring during hypergravitational stress and the time required for complete return to normal. Essentially the method used will consist in measuring the partial pressures of O<sub>2</sub>, CO<sub>2</sub> and N<sub>2</sub> in the mixed arterial blood and in the mixed alveolar air repeatedly during the stress and the recovery period. These measurements will be done at three different levels of oxygen concentration in the inspired gas (FiO<sub>2</sub>). From comparing the respective size of the alveolar arterial differences in O<sub>2</sub> and N<sub>2</sub> at the various FiO<sub>2</sub> levels during the stress, the contribution of the factors (shunt, low VA/Q) causing the arterial unsaturation will be calculated. Also, the type of low VA/Q units will be demonstrated. The same measurements during the period following the stress will serve to determine whether or not a complete return to normal may be expected. Also, these data will be used to calculate the size of the groups of lung units according to their VA/Q.

This research is likely to contribute to a better understanding of the VA/Q distribution in the normal environment of 1G as well as during hyper- and hypogravitational states. It may also lead to methods capable of minimizing these effects and/or increasing the speed of recovery.

It is planned to submit, in the near future, a research grant request to NASA for support of this co-operative study.

- (c) Study of dynamic changes in heart size, shape and position during acceleration by analysis of pictures of the videoimage, the photo exposures having been synchronized with the ECG so as to occur at the end-systolic and end-diastolic phases of successive cardiac cycles. A technic for obtaining biplane silhouettes of the heart with both images recorded simultaneously on each field of the video tape is being perfected so that measurements of heart volume at a frequency of 60 per second will be possible.
- (d) Development of videodensitometric technics for dynamic (greater than cardiac frequency) measurements of the diameters of a selected blood vessel in a uni- or biplane video image and the velocity of traversal of an indicator bolus through this segment of the vessel or the dimensions and areas (volume) of biplane cardiac silhouettes. This study requires the development of a technic for dynamic cancellation of background anatomic structures surrounding the vessels visualized by angiography. Background cancellation will be obtained by bucking, in opposite phase, the control against the

angiographic portions of the videotape recording obtained just prior to and during the passage of the roentgen opaque bolus through the segment of vasculature under study. This requires the use of three videotape recorders. Preliminary tests carried out at television station WMAQ-TV, Chicago, indicate the feasibility of the technic, which if successful will make possible measurements at a rate of 60/second of blood flow in any vessel in an undisturbed state in the body if the internal diameter of the vessel is about 2 mm. or more and if it is accessible by catheter technics for injections of a roentgen contrast medium.

- (e) Application of this technic to measurements of changes in blood flow to cephalic and caudal body structures and lung regions during exposures to headward acceleration (+G<sub>z</sub>) of rapid onset.
- (f) Attempts to apply this technic to measurement of coronary blood flow during these types of stress.
- (g) Correlation of changes in cerebral blood flow and the electroencephalogram during headward acceleration.

#### IV. General remarks in relation to past progress and future plans:

It should be emphasized that, except for the first of the above listed projects for future investigation (which is currently scheduled in the laboratory), there is no certainty as to just when and if the remaining lists of projects will be undertaken. The final decision as to the next future project which offers the greatest likelihood of maximum return of valuable information in relation to the time, cost and effort involved is dependent on the results from current projects. This list of projects is, therefore, only a series of best guesses as to future activities based on our current state of knowledge. The Mayo Centrifuge staff feels its main obligation is to elucidate the cardio-pulmonary effects of acceleration as expeditiously as possible. This obligation entails freedom to alter the chronology and nature of the attack on various phases of this problem as understanding of the relative importance of these phases evolves in the light of the current data.

This type of alteration in the chronology and nature of the laboratories attack on a specific problem is well illustrated in the case of the objectives listed for NASA Grant NsG-327 which were to develop the required cine roentgenographic technics and to apply them to roentgenographic studies of the pulmonary circulation in man. This project was given final approval by NASA October 1, 1962. The technic actually being used is based on videotape rather than cine recording. Due to the manufacturer's alterations in design and specifications of the videotape recorder, delivery of the tape recorder to the laboratory was delayed until June 1963. Completely new electronic technics for measurement of variations in roentgen opacity of any desired area of a tape recorded video image were then worked out and the device tested and put into operation in studies at 1G in September 1963. Since then, six preliminary reports have been prepared and published and several more are in preparation describing this exciting new video device and results obtained therefrom.

In spite of all pressures that could be brought to bear, the special ruggedized image intensifier-image orthicon assembly for use on the centrifuge was not

delivered until December 1963. Installation of this assembly in a newly designed and fabricated cockpit on the centrifuge was completed March 1964. Since that time a series of centrifuge experiments with dogs has been carried out using this assembly. The results from these experiments which are still undergoing analysis have formed the basis of five preliminary reports, one of which has been published and four of which are in press.

During the course of these intensive studies with this new technic, it has been found necessary to redesign nearly all of the electronic circuitry in the image orthicon video assembly so as to be able to use the videodensitometer as a quantitative instrument for dynamic measurements of concentration of contrast media as well as a qualitative recording device. The videodensitometer itself has now undergone redesign and will be replaced by a new densitometer with greatly improved characteristics.

These delays and difficulties have been outlined in part in the four semi-annual NsG-327 status reports submitted to NASA during the grant period. Their magnitude and complexity is not unexpected in a project of this degree of technical difficulty. Of greater importance is the fact that the Mayo Centrifuge staff possessed a sufficient degree of flexibility to keep the overall project going in a very active and productive fashion while these technical difficulties were being surmounted. The laboratory is only now at a stage where it appears that quantitative roentgen videodensitometric studies of the pulmonary circulation can be carried out with reasonable assurance of success. These are planned for the coming year as outlined above.

- V. A summary of a portion of the results of the most recently completed centrifuge experiments is given in the following preprints of manuscripts to be given as part of the scientific programs of April 1965 meetings of the Aerospace Medical Association and Federated Societies of Experimental Biology.

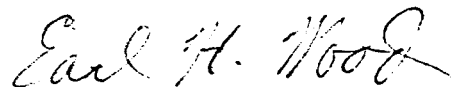

Earl H. Wood, M.D., Ph.D.

EHW:JF

Enclosures:

- Pleural Pressures in Dogs During Transverse Acceleration, Rutishauser et al.
- Effect of Forward, Backward, Right Lateral and Left Lateral Acceleration on Blood Oxygen Saturation in Dogs, Banchemo et al.
- Pericardial Pressures in Different Body Positions During Transverse Acceleration in Dogs Studied Without Thoracotomy, Banchemo et al.

## PLEURAL PRESSURES IN DOGS DURING TRANSVERSE ACCELERATION

H. Rutishauser, M.D., N. Banchemo, M.D., A. Tsakiris, M.D., R. E. Baum and  
E. H. Wood, M.D., Ph.D.

Mayo Clinic, Mayo Graduate School of Medicine, Rochester, Minnesota

Seven morphine-pentobarbitized dogs were exposed to forward (+G<sub>x</sub>), backward (-G<sub>x</sub>), right later (+G<sub>y</sub>) and left lateral (-G<sub>y</sub>) accelerations at average levels of 2.1, 4.3 and 6.6G in each direction while the animals were supported in molded half-body casts. Pleural pressures at a dorsal (paravertebral), ventral (retrosternal), a left and a right lateral site in the thorax at the level of the heart were measured simultaneously by saline-filled, percutaneously inserted radio-opaque teflon catheters (I.D. and O.D.: 0.7 and 1.3 mm., respectively) connected to P23D Statham gauges. In addition, airway pressure, esophageal, pericardial and circulatory pressures from aorta, right ventricle and both atria as well as oxygen saturation of femoral and pulmonary artery blood were recorded continuously (see preprint by Banchemo et al).

Corrections for the effect of acceleration on the catheter-manometer system were determined by "thistle-tube runs" (Figure 1). These are special runs composed with the actual pressure recording runs during which the strain gauges are closed to their catheters but opened via their hydraulic flushing systems to vertical glass cylinders located on either side of the thorax about at the level of the A-V valves in the cephalo-caudad dimension of the dog. The saline menisci (zero reference level) in these interconnected cylinders were adjusted to the mid-lung level. During the thistle-tube run, the rate of centrifuge rotation and the angle of tilt of the cockpit are set the same as during the actual pressure run. Therefore the baseline shift, due to the effect of acceleration on the transducers and the hydrostatic system, is determined so that all pressures can be referred to mid-lung level. Pleural, esophageal and pericardial pressures were also corrected to the level of the respective catheter tips on the basis of the vertical distance of each tip from mid-lung plane measured from biplane x-rays taken at expiration after about 55 seconds of exposure.

All dogs were subjected to necropsy at the end of the experiment to verify the positions of the catheters. The thoraces were opened under water. No air could be detected in the pleural space of the animals on which this report is based. Figures 1-3 partially summarize the results. Since the dorsal-ventral dimensions of the lungs of adult men are about one-third larger than those of the dogs studied, the levels and differences in pleural pressures at similar levels of acceleration would be expected to exceed those recorded in this study although differences in the configuration of the thorax may result in regional differences in the two species. (Supported by research grants NASA Nsg-327, NIH HE-03532, and AHA C-1000).

**Figure 1:** Illustration of method for obtaining zero reference pressure levels during centrifuge rotation and for determination of pressure at the tip of an intrapleural catheter using biplane roentgenograms. "A" and "B" indicate x-ray plates for lateral and A-P projections of the thorax.

The center oval indicates a cross-section of the thorax at the level of the heart (cross-hatched area). The lungs are indicated as stippled areas and the fluid columns in the catheter (C), strain-gauge manometer (P) and thistle-tube

systems ( $M_1$  and  $M_2$ ) by diagonal lines. The zero reference pressure selected for the strain gauge (P) is at mid-lung level.

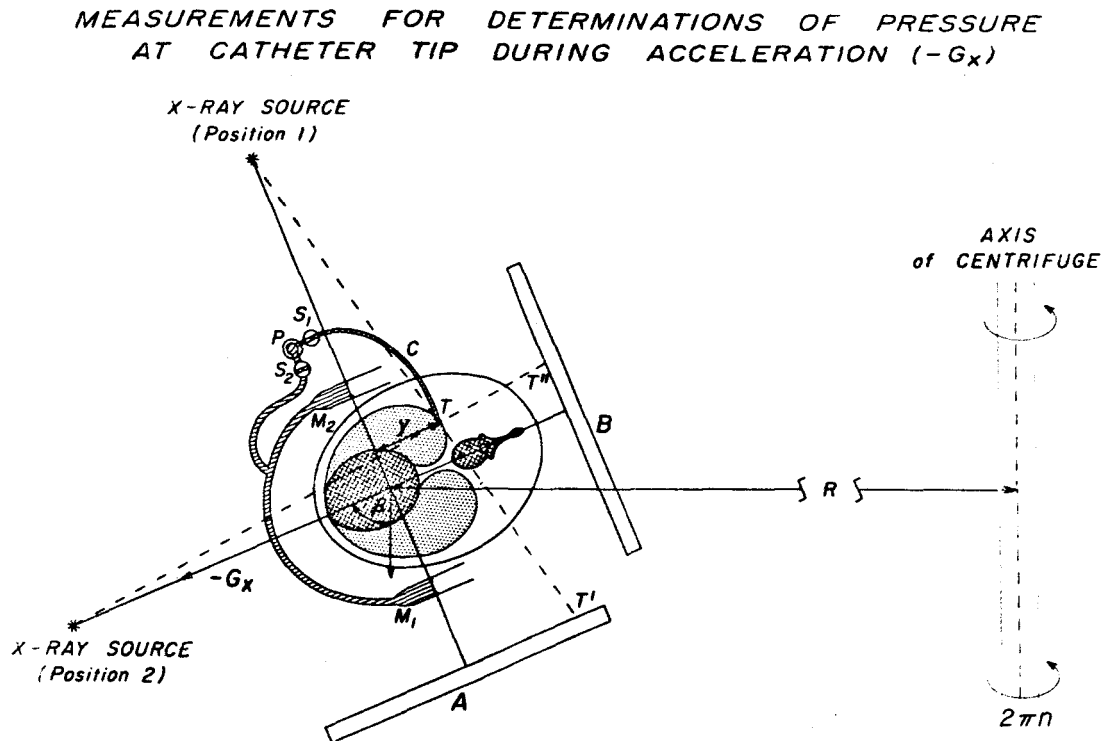

The level of the menisci of the bilateral thistle-tube system visualized the x-ray by lead containing floats is adjusted to mid-lung level as determined roentgenographically. The zero reference pressure of the manometer is then determined by closing stopcock  $S_1$  and opening stopcock  $S_2$  so that the strain-gauge manometer is exposed to a fluid column whose meniscus is at mid-lung level and exposed to ambient atmospheric (zero) pressure. The height of the radio-opaque catheter tip (T) above this mid-lung level is determined by measurement of its position from the biplane roentgenograms (A) and (B) with appropriate geometrical corrections for distortion due to divergence of the respective roentgen beams. Pressures recorded at "P" can then be corrected to the desired point "T" at the catheter tip, which in this instance is at the dorsal surface of the lung.  $\theta$  is the angle from the vertical of the resultant vector  $-G_x$  of the centripetal acceleration (R) and the 1G force of gravity.

**Figure 2:** Average and range of distortion and displacement of heart and lungs in 7 dogs by exposure to an acceleration of 6 to 7  $+G_x$ . Note that the normally thin region of lung parenchyma between the ventral border of the heart and the chest wall at 1G (left panel) is apparently distended during exposure to 6 to 7G (right panel) to occupy a large portion of the cross-sectional area of the chest. This is caused by the highly negative retrosternal intrapleural pressures which develop during acceleration while the level of atmospheric pressure distending the alveoli is undiminished and is responsible for the disruption of pulmonary parenchyma which has been observed under these conditions.

TOPOGRAPHIC RELATION OF HEART AND LUNGS  
DURING FORWARD ACCELERATION  
(MEAN VALUES OF 7 DOGS - Level of Sixth Vertebra)

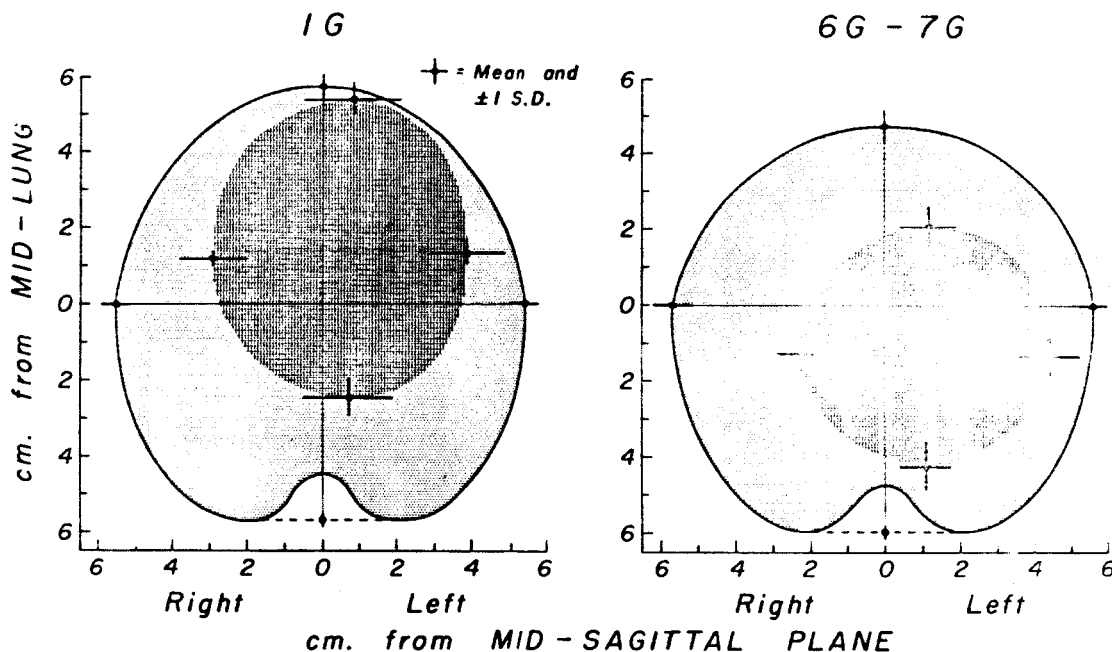

Figure 2

INFLUENCE OF FORWARD (+G<sub>x</sub>) AND BACKWARD (-G<sub>x</sub>)  
ACCELERATION ON INTRAPLEURAL PRESSURES  
AT DORSAL AND VENTRAL SITES IN 7 DOGS

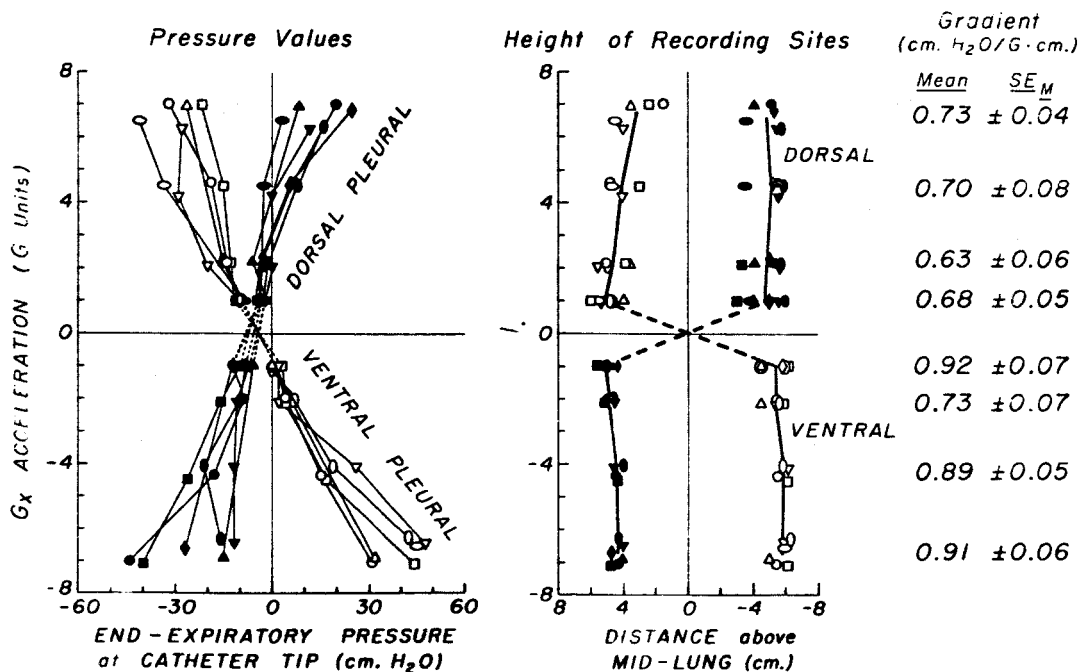

Figure 3 (Upper Panel)

Figure 3 (Upper Panel): Influence of forward (+G<sub>x</sub>) and backward (-G<sub>x</sub>) acceleration on intrapleural pressures at dorsal (paravertebral) and ventral (retrosternal) sites in the thorax of 7 dogs. Note that in the dependent regions in the thorax, intrapleural pressures increase to positive values at the higher levels of acceleration so that lung collapse and pulmonary arterial venous shunts would be expected to occur in these regions. Concomitantly highly negative values of intrapleural pressure occur in superior regions of the thorax.

INFLUENCE OF RIGHT LATERAL (+G<sub>y</sub>) AND LEFT LATERAL (-G<sub>y</sub>) ACCELERATION ON INTRAPLEURAL PRESSURES AT LEFT LATERAL AND RIGHT LATERAL SITES IN 7 DOGS

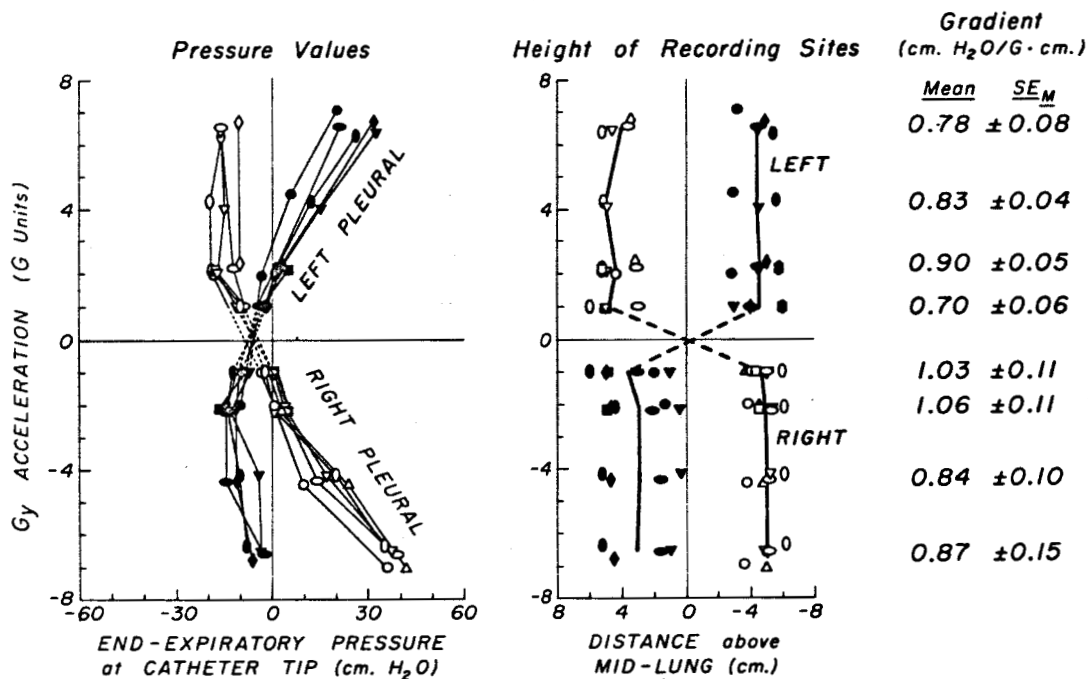

Figure 3 (Lower Panel): Analogous values determined at bilateral thoracic sites during lateral acceleration, plus and minus G<sub>y</sub>.

Note that the interpolated values for pleural pressures at zero G (inter-section of dashed lines at zero G axis) are closely similar (about -6 cm. H<sub>2</sub>O) at these four different sites in the thorax as would be expected under weightless conditions. Analogous esophageal pressures at zero G were about -3 cm. H<sub>2</sub>O which supports the finding that estimated pleural pressures corrected to the same vertical height as the esophageal catheter tip were 2 to 3 cm. H<sub>2</sub>O more negative than the esophageal pressure. The equality of pleural pressure values at different sites in the thorax at zero G confirms the conclusion that the differences in pleural pressures, which have been observed at different sites in the thorax in the normal 1G environment, are caused by the weight of the thoracic contents.



THE EFFECT OF FORWARD, BACKWARD, RIGHT LATERAL AND LEFT LATERAL ACCELERATION  
ON BLOOD OXYGEN SATURATION IN DOGS

N. Banchemo, M.D., W. Rutishauser, M.D., A. Tsakiris, M.D., R. E. Sturm and  
E. H. Wood, M.D., Ph.D.

Mayo Clinic and Mayo Graduate School of Medicine, Rochester, Minnesota

In seven dogs under morphine-pentobarbital anesthesia, blood oxygen saturations from femoral and pulmonary arteries were recorded continuously by cuvette oximeters during 60-second exposures to transverse acceleration with the animal supported in four different body positions by half-body casts. Average levels of exposure in each body position were 2.1, 4.4, 6.7 and again 6.7G corresponding to forward (+G<sub>x</sub>), backward (-G<sub>x</sub>), right lateral (+G<sub>y</sub>), and left lateral (-G<sub>y</sub>) acceleration while the animals were breathing room air. In five animals, additional exposures to levels of 6 to 7G were carried out in each body position with the animals breathing 99.6% oxygen. In four animals, exposures to forward acceleration were repeated between 10 and 16½ hours after the first series in the same position. In one dog (#7), an added series of exposures to backward acceleration was performed at the end of the experiment. Airway pressure variations were recorded at the oral end of an endotracheal tube. Thoracic roentgenograms were taken at 1G and repeated approximately 55 seconds after attainment of the plateau level of acceleration. In addition, pressures were recorded from both atria, right ventricle, aorta, esophagus and the potential pleural and pericardial spaces (see preprint by Rutishauser et al).

The relation of total cumulative exposure to the three levels of acceleration in the four body positions studied to control (1G) cardiac output and control (1G) femoral artery oxygen saturation is shown in Figure 1. The duration of the experiment is on the abscissa, zero corresponding to the time the dog was placed in the centrifuge cockpit.

Average control values for cardiac output at the beginning of the experiments and approximately 8½ and 15½ hours after zero time of 1.7, 2.1 and 1.9 L./minute, respectively were not significantly different.

No systematic difference in femoral artery oxygen saturation was observed comparing the control (1G) values obtained in the different body positions before the series of exposures in that position were performed and control values obtained at the beginning of the experiments.

Usually recovery of femoral artery oxygen saturation, after exposures to a series of different levels of acceleration in a given body position, was not complete in the five to fifteen-minute intervals between the exposures. Therefore, 1G control values prior to exposures to 4-5 and 6-7G were generally lower than the 1G control value observed just prior to the initial exposures, which was to 2G, in each position.

A comparison of the effects of similar levels of transverse acceleration on oxygen saturation of arterial blood, when in different body positions, is shown in Figure 2.

During exposures to 2.1G, no systematic changes in arterial oxygen saturation occurred in the four different body positions. During transverse acceleration to 4 to 5G, the mean decreases in saturation of 13, 7, 13, and 18% caused by +G<sub>x</sub>, -G<sub>x</sub>, +G<sub>y</sub>, and -G<sub>y</sub>, respectively, were not significantly different. The respective

... increases of 18, 15, 17, and 22% observed after 55 seconds at 6 to 7G were similar in each of the four positions. Corresponding average decreases of mixed venous blood were 6, 8, 10, and 12% for  $+G_x$ ,  $-G_x$ ,  $+G_y$ ,  $-G_y$ , for accelerations of 6 to 5G while the respective decreases for 6 to 7G were 13, 12, 15 and 15%.

In all body positions, the administration of oxygen delayed but did not prevent the arterial desaturation. Thoracic roentgenograms showed displacement of the heart towards the dependent parts of the thorax and increase in radiopacity of the dependent region with concomitant increase in radiolucency in the non-dependent portions of the lungs. These striking decreases in arterial oxygen saturation during transverse acceleration are similar to those observed during centrifugation on healthy human subjects. Presumably therefore, similar degrees of arterial hypoxemia occur during the launch and re-entry phases of manned space flights as a result of the dependent pulmonary atelectasis and concomitant ventilation-perfusion mismatch of alveoli which these levels of acceleration produce. (Supported by research grants NASA NSG-327, NIH HE03532, and AHA CX 10.)

RELATION OF TOTAL CUMULATIVE EXPOSURES TO TRANSVERSE ACCELERATION TO CONTROL ARTERIAL OXYGEN SATURATION AND CARDIAC OUTPUT AT 1G

(7 Dogs, Morphine-Pentobarbital Anesthesia)

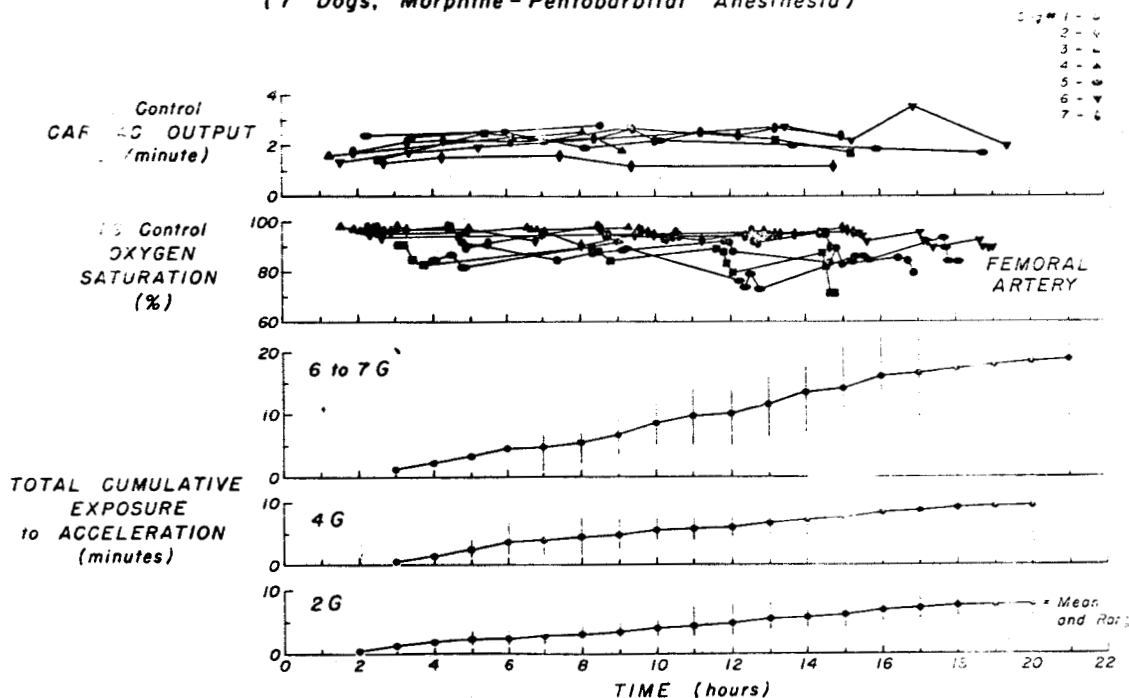

Figure 1: Relation of total cumulative 60-second exposures to transverse acceleration at levels of 2, 4, and 6 to 7G to the control (1G) femoral artery oxygen saturation and cardiac output at 1G. The two upper panels show individual values for the 7 dogs studied, identified by the respective symbols. Zero time was taken as the time when the dog was placed in the centrifuge cockpit. The average total cumulative exposure to the three levels of acceleration in the different positions studied and ranges are shown in the lower three panels. The values for cardiac output were determined by the dye-dilution technic at intervals during the experiment when dogs were at 1G and showed no systematic deviation with duration of the procedure. Similarly, the values for arterial oxy

saturation prior to exposure to increased levels of acceleration in each body position were not significantly different and showed no systematic variation with the duration of the procedure. However, in some dogs there was a progressive decrease in arterial saturation during individual series of exposures which were separated by intervals of 5 to 15 minutes.

**EFFECT OF TRANSVERSE ACCELERATION ON OXYGEN SATURATION OF ARTERIAL BLOOD IN 7 DOGS AFTER 55 SECONDS EXPOSURE (Morphine-Pentobarbital Anesthesia)**

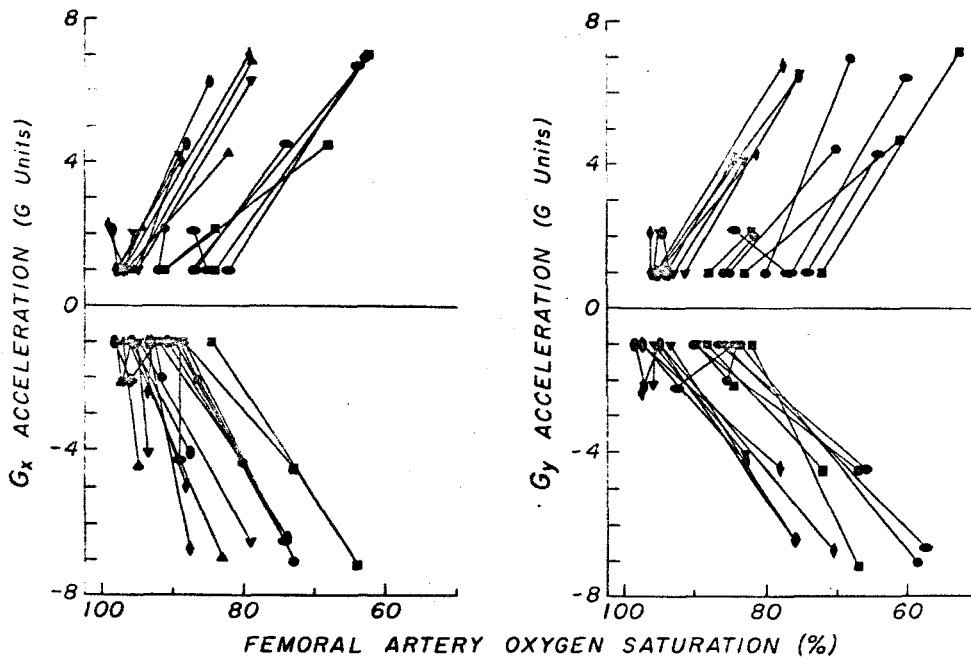

Figure 2: Comparison of the effects after 55 seconds of exposure to similar levels of transverse acceleration in four different body positions on oxygen saturation of arterial blood. Values obtained in the supine (+G<sub>x</sub>) and prone (-G<sub>x</sub>) positions are shown in the left-hand panels and those in the right decubitus (-G<sub>y</sub>) and left decubitus (+G<sub>y</sub>) in the right. Each symbol represents an individual dog as indicated in Figure 1. The control values (i.e., those observed at 1G just prior to each exposure) are connected by the lines to the respective values obtained approximately a minute later during exposure to acceleration. Systematic changes in arterial saturation were not observed at 1G. Significant decreases in arterial saturation occurred with one exception during each exposure to 4-5G and uniformly more severe degrees of arterial hypoxemia resulted at 6-7G. Note that: (1) the decrement in arterial saturation during an exposure did not vary systematically with the control (1G) value for arterial saturation obtained just prior to the exposure, (2) there was no clearly evident difference between the results obtained in the supine (+G<sub>x</sub>) and prone (-G<sub>x</sub>) positions and, (3) the degree of arterial hypoxemia was somewhat more severe in the lateral (+G<sub>y</sub> and -G<sub>y</sub>) decubitus positions.

PERICARDIAL PRESSURES IN DIFFERENT BODY POSITIONS  
DURING TRANSVERSE ACCELERATION IN DOGS STUDIED WITHOUT THORACOTOMY

N. Banchemo, M.D., W. Rutishauser, M.D., A. Tsakiris, M. D. and  
E. H. Wood, M.D., Ph.D.

Mayo Clinic and Mayo Graduate School of Medicine, Rochester, Minnesota

Pericardial pressures were measured via a percutaneously introduced fluid-filled teflon catheter (O.D. 1.3 mm.) before and during one-minute exposures to forward (+G<sub>x</sub>), backward (-G<sub>x</sub>), right lateral (+G<sub>y</sub>) and left lateral (-G<sub>y</sub>) acceleration at the average levels shown below. Pressures were also recorded from both atria, right ventricle, aorta, esophagus and the potential pleural spaces. The table shows average values of mean end-expiratory pericardial pressures referred to catheter-tip level and the vertical distances (cm.) of the catheter tip above the mid-lung reference plane.

	<u>FORWARD</u>				<u>BACKWARD</u>			
Acceleration (G)	1.0	2.1	4.5	6.7	1.0	2.1	4.4	6.7
Vertical Distance	3.8	3.0	0.7	0.1	-4.1	-4.7	-4.6	-4.4
Pressures (cm. H <sub>2</sub> O)	-5.9	-11.0	-9.3	-6.3	0.6	4.0	9.6	30.6
	<u>RIGHT LATERAL</u>				<u>LEFT LATERAL</u>			
Acceleration (G)	1.0	2.2	4.3	6.6	1.0	2.1	4.3	6.7
Vertical Distance	-1.3	-1.1	-0.4	-2.0	-0.7	-1.3	-1.1	-1.8
Pressure (cm. H <sub>2</sub> O)	-5.3	-2.5	-2.0	11.2	-3.0	0.7	6.3	18.3

Relationships between pericardial pressures and vertical positions were as expected for a hydrostatic system under all conditions studied (Figure 1). Since mean atrial pressures also behave as a hydrostatic system, transmural right and left atrial pressures were largely unaffected by transverse acceleration in spite of levels of pericardial pressure which averaged over 30 cm. H<sub>2</sub>O at 6-7G when in the prone position (Figure 2). (Supported by Research Grants NASA NsG-327, NIH HE03532, and AHA CI 10.)

Figure 1 (Upper and Lower Panels): Variations of pericardial pressure with the level of acceleration and the vertical height of the recording site in the thorax of 7 dogs studied without thoracotomy.

INFLUENCE OF FORWARD (+G<sub>x</sub>) AND BACKWARD (-G<sub>x</sub>) ACCELERATION ON INTRAPERICARDIAL PRESSURE IN 7 DOGS

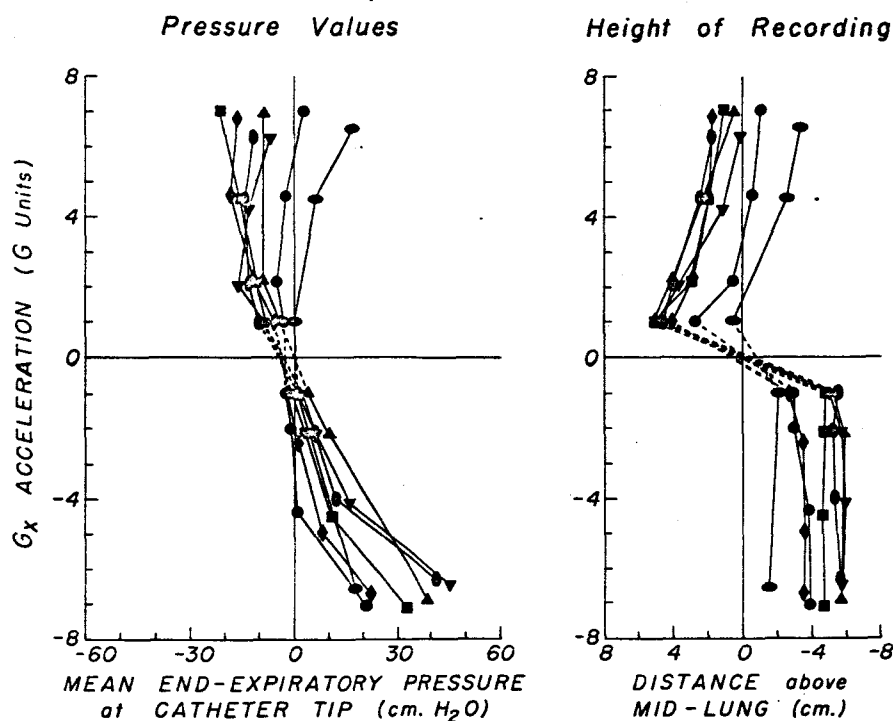

Figure 1 (Upper Panel): G<sub>x</sub> Acceleration

Note in the right-hand panel that when the dog was supine (+G<sub>x</sub> acceleration), the catheter tip was above (ventral to) the mid-lung plane at 1G in every instance but was displaced progressively lower in the thorax with the dorsalward movement of the heart at higher levels of acceleration. When the dog was prone (-G<sub>x</sub> acceleration), however, the heart was resting on the sternum at 1G and there was practically no additional downward (ventral) displacement during acceleration. Note also that pressure at the catheter tip (left panel) became increasingly positive with increasing acceleration if the catheter tip was located below mid-lung level and vice versa. The average level of pericardial pressure interpolated to zero G (intersections of dashed lines with zero G line) was about -3 cm. H<sub>2</sub>O.

INFLUENCE OF RIGHT LATERAL (+G<sub>y</sub>) AND LEFT LATERAL (-G<sub>y</sub>) ACCELERATION ON INTRAPERICARDIAL PRESSURE IN 7 DOGS

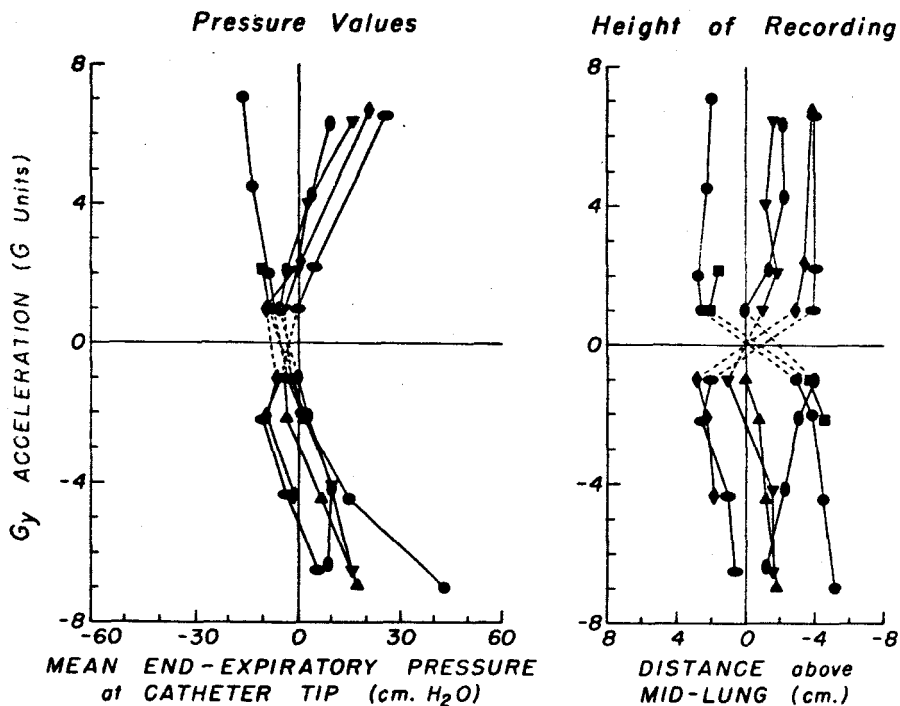

Figure 1 (Lower Panel): G<sub>y</sub> Acceleration

Note that, as is the case for G<sub>x</sub> acceleration, progressively more positive pericardial pressures were recorded with increasing acceleration when the catheter tip was below mid-lung level and vice versa.

The average of the interpolated values for pericardial pressure at zero G (when the dogs were in the right and left decubitus positions) of about -3 cm. H<sub>2</sub>O was not significantly different from the mean value of -3 cm. H<sub>2</sub>O obtained for the prone and supine positions. This is confirmation of the hypothesis that the differences in pericardial and pleural pressures at different sites in the thorax observed during exposure to 1G and above are caused by the weight of the thoracic contents since, if this were the case, these differences would be expected to disappear under conditions of weightlessness.

INFLUENCE OF FORWARD (+G<sub>x</sub>) AND BACKWARD (-G<sub>x</sub>)  
ACCELERATION ON ATRIAL PRESSURES  
(Values in 7 Dogs, Morphine-Pentobarbital Anesthesia)

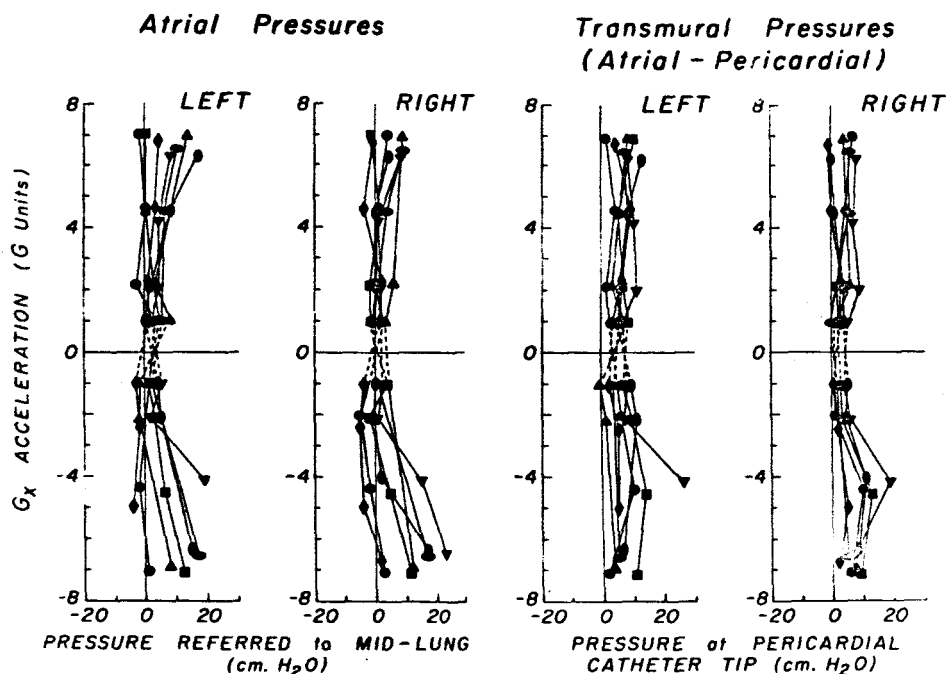

Figure 2: Relation of atrial pressures to the level of transverse acceleration when in the supine (+G<sub>x</sub>) and the prone (-G<sub>x</sub>) body positions.

Note (left panels) that at mid-lung level there was only a slight systematic increase in atrial pressures in these 7 dogs over the range from +7G<sub>x</sub> to -7G<sub>x</sub> acceleration. This indicates that the hydrostatic indifference point of atrial pressure in dogs is at approximately mid-lung level. However, since the average dorsal-ventral dimension of the lungs of these dogs was 12 cm., this indicates that at +7G<sub>x</sub> the pulmonary venous pressure at the most dependent (dorsal) regions in the lungs averaged about 50 cm. H<sub>2</sub>O in these same dogs while at -7G<sub>x</sub> the pulmonary venous pressure at the most dependent (ventral) regions in the lungs averaged about 60 cm. H<sub>2</sub>O. Since these values are far in excess of the colloido-osmotic pressure of the plasma, rapid formation of pulmonary edema in dependent regions of the lungs would be expected to occur at these levels of acceleration - in addition to the dependent pulmonary atelectasis which develops because of the positive values for pleural pressure which have been demonstrated to occur in these same regions of the thorax under these conditions. The average of the interpolated values for zero G (intersections of dashed lines with zero G line) of about 2 cm. H<sub>2</sub>O for left atrial pressure was slightly greater than the interpolated average value of 1 cm. H<sub>2</sub>O obtained for right atrial pressure in the weightless condition.

Note (right panels) transmural atrial pressures (i.e., the differences between atrial and pericardial pressures corrected to the same vertical height in the thorax) were not systematically affected by the level of acceleration in the range from plus to minus 7G<sub>x</sub>, indicating that the volume of blood in the atria probably is not greatly changed by transverse acceleration of these magnitudes. The average interpolated values for transmural left atrial pressure at zero G (intersections of dashed lines with zero G line) of about 5 cm. H<sub>2</sub>O was slightly in excess of the average value for transmural right atrial pressure of about 3 cm. H<sub>2</sub>O obtained in these same 7 dogs under the interpolated condition of weightlessness.