

Technical Report No. 32-684

# Mariner Mars 1964 Telemetry and Command System

Richard P. Mathison

GPO PRICE \$ \_\_\_\_\_

OTS PRICE(S) \$ \_\_\_\_\_

Hard copy (HC) 2.00

Microfiche (MF) .50

FACILITY FORM 802

**N65-26146**  
(ACCESSION NUMBER)

27  
(PAGES)

Cr 63289  
(NASA CR OR TMX OR AD NUMBER)

\_\_\_\_\_  
(THRU)

1  
(CODE)

07  
(CATEGORY)

1965-06-01-1000  
 1965-06-01-1000  
 1965-06-01-1000

**JET PROPULSION LABORATORY**  
**CALIFORNIA INSTITUTE OF TECHNOLOGY**  
**PASADENA, CALIFORNIA**

June 1, 1965

*Technical Report No. 32-684*

***Mariner Mars 1964 Telemetry and  
Command System***

*Richard P. Mathison*

*Richard P. Mathison*

---

Richard P. Mathison, Manager  
Spacecraft Radio Section

**JET PROPULSION LABORATORY  
CALIFORNIA INSTITUTE OF TECHNOLOGY  
PASADENA, CALIFORNIA**

June 1, 1965

Copyright © 1965  
Jet Propulsion Laboratory  
California Institute of Technology

Prepared Under Contract No. NAS 7-100  
National Aeronautics & Space Administration

**CONTENTS**

**I. Introduction . . . . . 1**

**II. Radio Subsystem . . . . . 3**

**III. Telemetry Subsystem . . . . . 11**

**IV. Command Subsystem . . . . . 18**

**V. Performance . . . . . 19**

**Conclusion . . . . . 21**

**References . . . . . 22**

**TABLES**

**1. Spacecraft radio transmission parameters (2998 Mc) . . . . . 9**

**2. Spacecraft radio reception parameters (2116 Mc) . . . . . 10**

**3. DSN radio reception parameters (2298 Mc) . . . . . 10**

**4. DSN radio transmission parameters (2116 Mc) . . . . . 11**

**5. Time between samples . . . . . 13**

**6. Registered events . . . . . 15**

**7. Video storage characteristics . . . . . 15**

**8. Telemetry parameters . . . . . 17**

**9. Command parameters . . . . . 18**

**FIGURES**

**1. Mariner Mars 1964 spacecraft telecommunication system . . . . . 2**

**2. Spacecraft radio subsystem . . . . . 4**

**3. Circulator switch circuit . . . . . 5**

**4. Earth track vs time . . . . . 6**

**5. Mariner Mars 1964 spacecraft . . . . . 7**

**FIGURES (Cont'd)**

|  |    |
|--|----|
| 6. Typical low-gain antenna pattern . . . . .                    | 8  |
| 7. Spacecraft telemetry subsystem . . . . .                      | 12 |
| 8. Commutator, functional diagram . . . . .                      | 14 |
| 9. Video magnetic tape recorder . . . . .                        | 16 |
| 10. Received signal level vs time, spacecraft to Earth . . . . . | 19 |
| 11. Telemetry performance margin vs time . . . . .               | 20 |
| 12. Received signal level vs time, Earth to spacecraft . . . . . | 20 |
| 13. Command performance margin vs time . . . . .                 | 21 |

**ABSTRACT**

26146

The Telemetry and Command System for the *Mariner* Mars 1964 Mission utilizes an extension of the techniques used for the *Mariner* Venus 1962 Mission. For both the command and telemetry functions, PCM/PSK/PM modulation-demodulation in combination with pseudo-random sync codes is used.

The telemetry system is required to transmit video data from the vicinity of Mars in addition to transmitting other scientific and engineering data during the entire flight. Since the rate at which the video data is gathered exceeds the capability of the telemetry channel, storage and playback are provided by an endless-loop tape recorder. In order to provide the maximum reliability within the constraints of available power and weight, redundant elements have been incorporated in the telemetry modulator and the transmitter.

The command system provides for the transmission of both direct and quantitative commands to the spacecraft.

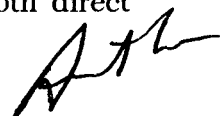
**I. INTRODUCTION**

The telecommunication system for the *Mariner* Mars 1964 Mission is comprised of spacecraft-borne equipment and the NASA Deep Space Net (Ref. 1). It is required to perform three functions: (1) track the position and velocity of the spacecraft, (2) telemeter engineering and scientific data from the spacecraft, and (3) transmit commands to the spacecraft. The design of the spacecraft equipment is based upon techniques that were used for the *Mariner II* spacecraft (Refs. 2, 3). These techniques have been extended and modified so as to improve equipment reliability, accommodate the increased communication range required by the Mars 1964 Mission, and utilize the characteristics of the Mars 1964 trajectories to effect simplifications in the spacecraft equipment.

Single CW radio frequency carriers that are transmitted to and from the spacecraft are used for tracking the spacecraft and transmitting the telemetry and command information. The functional arrangement of the spacecraft subsystems utilized to accomplish this is shown in Fig. 1. For both the telemetry and command functions, PCM/PSK/PM techniques in combination with pseudo-random sync codes provide efficient, accurate transmission of the data over interplanetary distances.

The telemetry portion of the system is required to transmit video data in digital form from the vicinity of Mars and both scientific and engineering data during the flight from Earth to Mars. Since the rate at which the

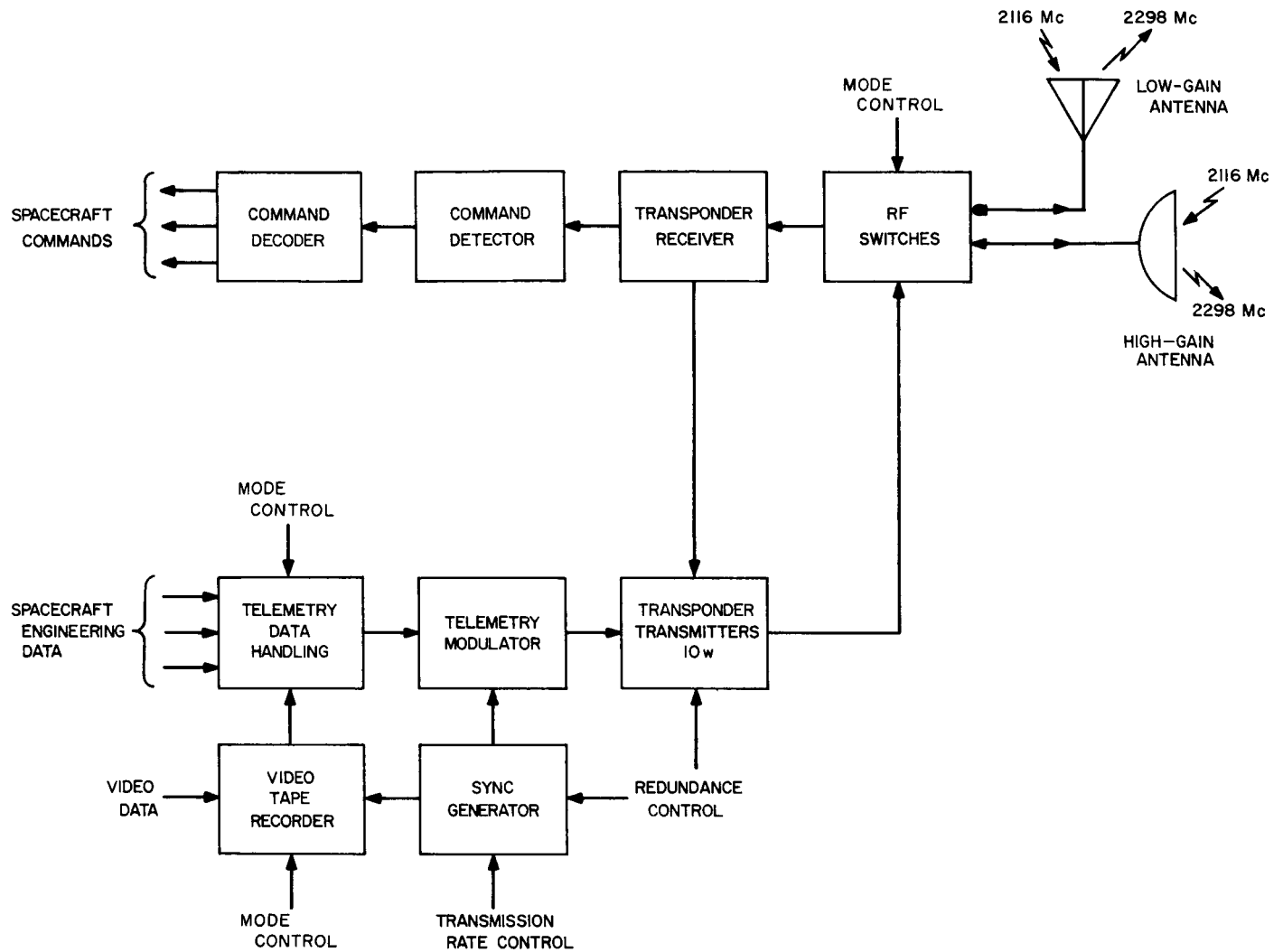

Fig. 1. Mariner Mars 1964 spacecraft telecommunication system

video data is gathered exceeds the capacity of the telemetry channel, data storage and playback are provided by a synchronous, endless-loop tape recorder capable of storing 20 frames of video data.

The duration of the Mars 1964 Mission is approximately 8 months, in contrast to the Venus 1964 Mission, the duration of which was 4 months. In order to accommodate this increased equipment operating time, modest reliability improvements were incorporated within the constraints of available power and weight. These improvements take the form of improved components, extensive part screening, worst-case circuit designs, and redundant elements in the telemetry modulator and transmitter.

By utilizing the unique characteristics of the Mars 1964 minimum-energy trajectories (Ref. 4), considerable sav-

ings in spacecraft weight and complexity were realized. The variation in Earth, spacecraft, Sun, and Canopus geometry permitted the use of a moderately high-gain antenna that is fixed with respect to the spacecraft and thus eliminated the need of antenna pointing mechanisms.

The command system provides for the transmission of both direct and quantitative commands to the spacecraft in digital form.

This report describes the requirements and mechanization of the spacecraft-borne subsystems of the telecommunication system, with particular emphasis on the telemetry and command functions. A detailed discussion of the scientific instruments and the data automation system which controls and interfaces with the instruments is beyond the scope of this report and is not

included (Ref. 5). Further, a detailed discussion of the modulation-demodulation theory that forms a basis of the data transmission techniques has been adequately

covered elsewhere (Refs. 6-8) and is not repeated here. Estimates of expected communication performance are included.

## II. RADIO SUBSYSTEM

The radio subsystem is required to receive a modulated RF carrier from stations of the Deep Space Net, demodulate command and ranging signals, coherently translate the frequency and phase of the RF carrier by a fixed ratio, modulate the carrier with telemetry and ranging signals, and retransmit it back to Earth. As shown in Fig. 2, the radio subsystem consists of an automatic phase control receiver, redundant exciters, redundant power amplifiers, power supplies, low- and high-gain antennas, and associated transmission and control circuits. It operates at S-band frequencies, receiving at 2116 mc and transmitting at 2298 mc.

As received from Earth, the up-link RF signal is phase-modulated either singly or simultaneously by a composite command signal and a coded ranging signal. It is of the form shown in Eq. (1);

$$S_R = A(\gamma, r) \sin [\omega_0 t' + \phi_c(t') + \phi_r(t')] \quad (1)$$

$$t' = t - \frac{r(t)}{c} \quad (2)$$

where

$A$  is the received signal level, a function of the spacecraft attitude  $\gamma$  and the spacecraft-Earth range  $r$

$\omega_0$  is the carrier frequency transmitted by a DSN station

$\phi_c$  is the phase modulation by the composite command signal

$\phi_r$  is the phase modulation by the coded ranging signal

$r(t)$  is the spacecraft-Earth range, a function of time  $t$

$c$  is the velocity of propagation

This signal is demodulated by the automatic phase control, double superheterodyne receiver which tracks the  $\omega_0 t'$  component of the carrier phase. The composite command modulation and coded ranging signals are sent to the command detector and the exciter phase modulators, respectively. When the receiver is phase-locked to the received signal, it generates a filtered phase reference for the transmitter exciter which is coherent with the  $\omega_0 t'$  component of the received signal. The phase of the transmitted signal is then related to the phase of the received signal by a fixed ratio to within an error of less than 1 radian rms. The resulting transfer function is given approximately by

$$\frac{\theta_T}{\theta_R} = \frac{240}{221} \left[ \frac{1 + \frac{3}{4B} s}{1 + \frac{3}{4B} s + \frac{1}{2} \left( \frac{3}{4B} \right)^2 s^2} \right] \quad (3)$$

where

$s$  is the Laplace variable and  $B$  is the effective noise bandwidth of the receiver phase tracking loop

$\theta_T$  is the phase of the transmitted signal

$\theta_R$  is the phase of the received signal

With this relationship the ground stations are provided with a signal that permits two-way doppler tracking (Ref. 9).

The transmitted signal is phase-modulated by a composite telemetry signal and the coded ranging signal. While the telemetry signal modulates the carrier continuously, the ranging modulation can be turned on or off by ground command.



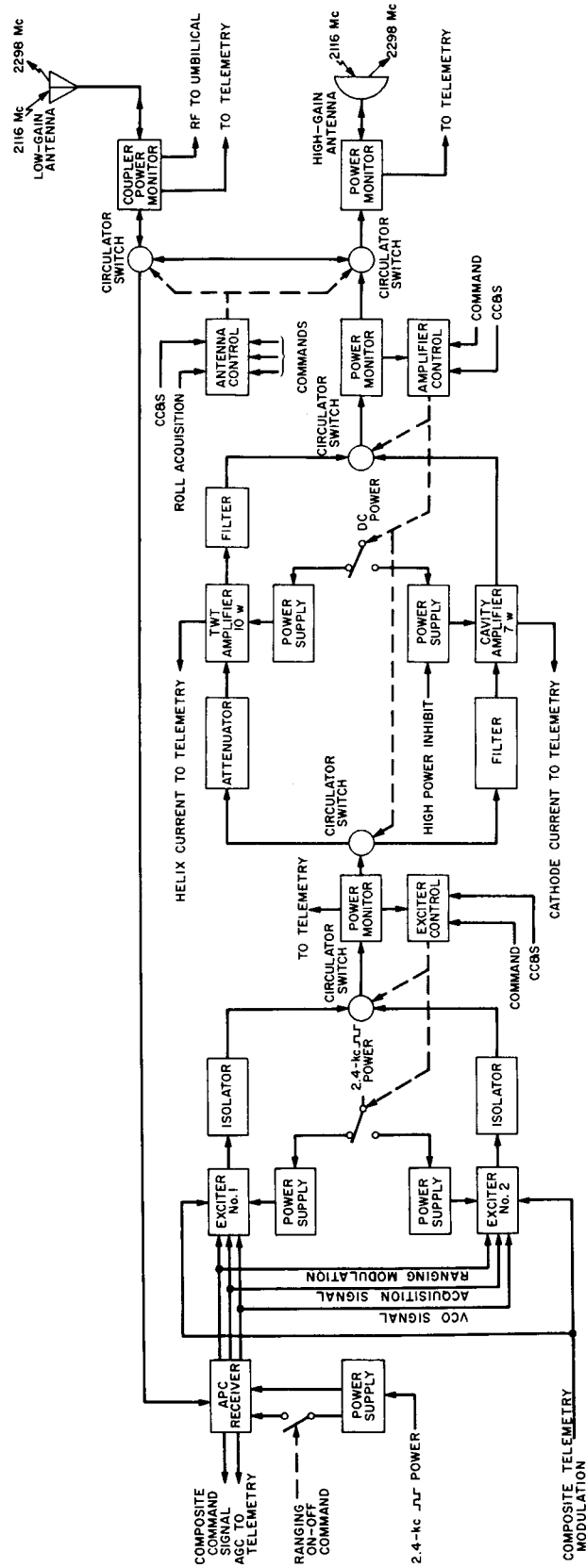

Fig. 2. Spacecraft radio subsystem

When a signal is not being transmitted to the spacecraft, transmitter frequency control is provided by an auxiliary crystal oscillator. This noncoherent mode of operation permits one-way doppler tracking, angular position tracking, and telemetry reception by the ground stations.

In order to provide increased reliability over the *Mariner II* design, redundant exciters, power amplifiers, and power supplies have been incorporated in the transmitter. Each exciter consists of an auxiliary oscillator, a  $\times 4$  frequency multiplier, a phase modulator, a  $\times 30$  frequency multiplier, and an output isolator. As shown in Fig. 2, either exciter can be coupled to either power amplifier by a circulator switching network. Similarly, the input and output circuits of the power amplifiers are coupled through circulator switches.

The control of the switching between these elements is provided by either ground command or on-board failure detection. In the case of ground command control, the receipt of the appropriate direct command causes the control unit to simultaneously transfer the DC power from the active to the inactive element and reverse the circulator switch or switches. For the exciters, the modulation, phase reference, and mode control inputs are fed to both exciters in parallel.

In the case of switching by on-board failure detection, power monitors sample both the exciter and power amplifier RF power outputs. When an output power drops below a preset level, a gate in the control unit is enabled which allows cyclic pulses from the control computer and sequencer (CC&S) to toggle the relay driver circuit. Upon the receipt of one such pulse, the control unit transfers the DC power and RF circuits in the same manner as when a ground command is received. If the power output from the redundant element then exceeds the threshold, the gate inhibits further transmission of pulses to the driver circuit. The thresholds for enabling the gates are set at 3 db below the nominal exciter and power amplifier outputs. The cyclic pulses occur once every  $66\frac{2}{3}$  hr. Thus, the maximum switching after a failure is  $66\frac{2}{3}$  hr.

Circulator switches were chosen for the control of the RF transmission paths because they appeared to offer significant reliability advantages over conventional electromechanical coaxial switches. As an RF circuit, the circulator is simply a strip-line "Y" connection with no moving parts. The Y is surrounded by a ferrite material that is polarized by a DC electromagnetic field. Signal

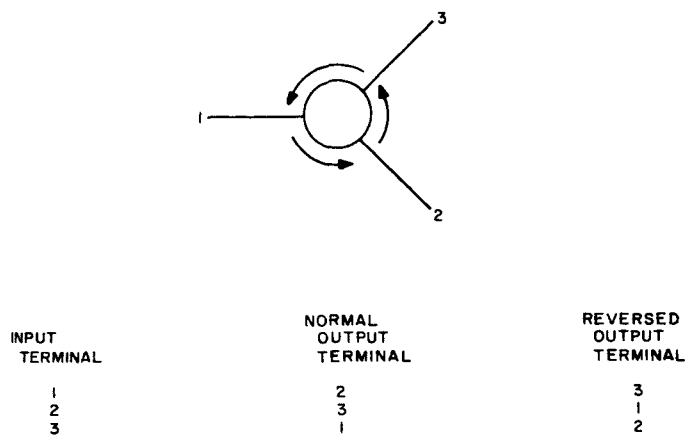

Fig. 3. Circulator switch circuit

flow through the device is circular as indicated in Fig. 3. By reversing the magnetic field, the signal can be made to "circulate" in the opposite direction and hence the switching action. In the event of a loss in electromagnetic field, the circuit will function like a transmission line "T", with the attendant power splitting and increased mismatch losses, but will not cause a complete loss of performance.

The *Mariner Mars 1964* spacecraft uses both the Sun and the star Canopus for attitude references. Sun sensors provide pitch and yaw control such that the roll axis is pointed toward the Sun, and the Canopus sensor provides roll position control. With this type of attitude control the position of Earth as seen from the spacecraft (the direction of the spacecraft-Earth vector relative to the spacecraft coordinate system) varies as shown in Fig. 4 for a typical Mars 1964 trajectory (Ref. 4).

It can be seen that the locus remains within one hemisphere of the spacecraft during the entire flight and within a relatively small angular region during the later portion of the flight from 130 days before Mars encounter to 20 days past encounter. A comparison of this characteristic and the required minimum antenna gain vs time-of-flight showed that the gain requirements could be met with a combination of one low-gain and one high-gain antenna, both of which were fixed relative to the spacecraft (Fig. 5). The low-gain antenna provides coverage during the first 70 to 95 days of flight, while the high-gain antenna fills in the remaining period until approximately 20 days past encounter.

The low-gain antenna consists of a cruciform aperture at the end of a low-loss circular wave guide which also

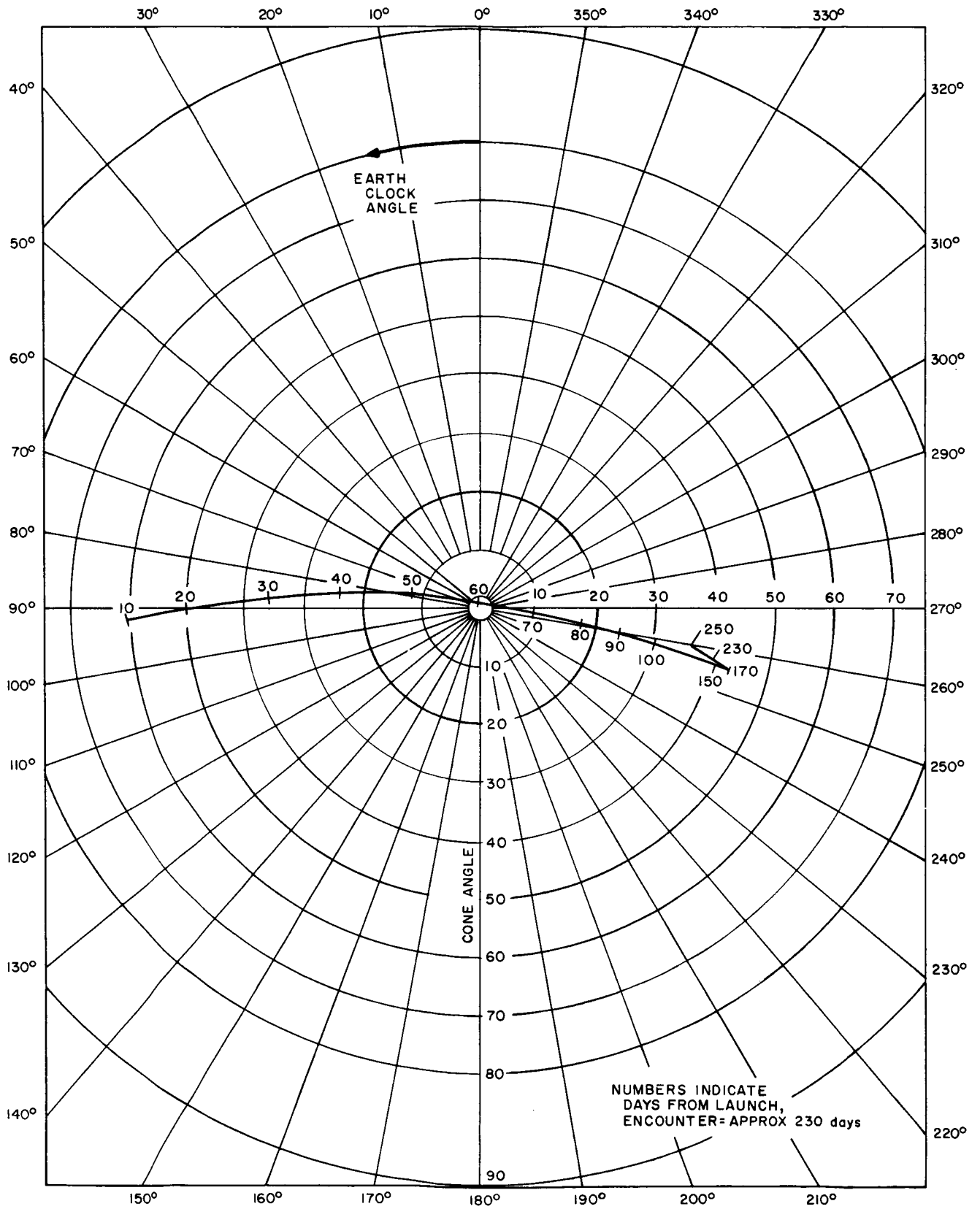

Fig. 4. Earth track vs time

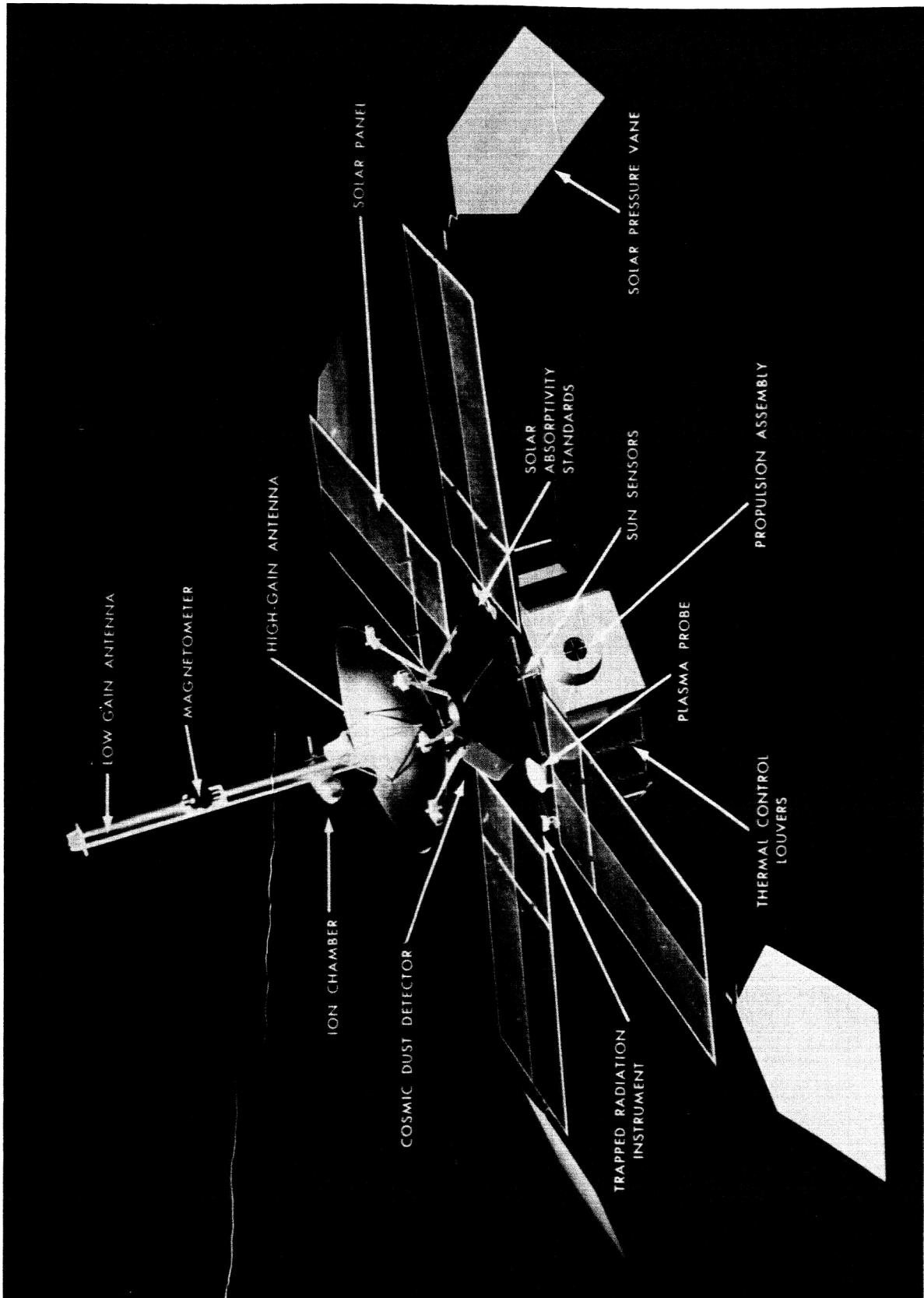

Fig. 5. Mariner Mars 1964 spacecraft

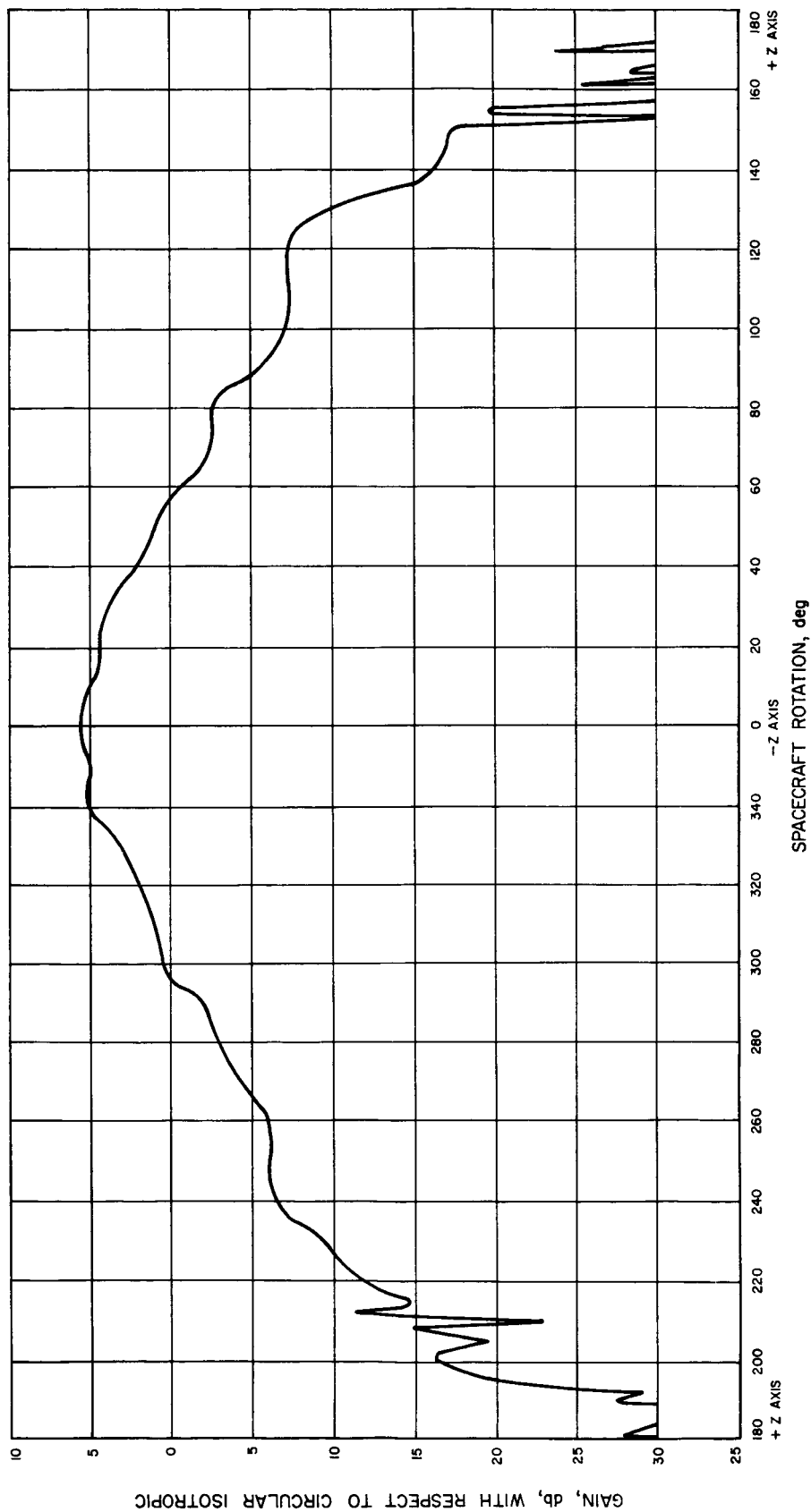

Fig. 6. Typical low-gain antenna pattern

functions as the support structure. In order to minimize pattern distortion by reflections from the spacecraft structure, the aperture is mounted well away from the bulk of the spacecraft. As shown in Fig. 6, the antenna provides a pattern of revolution about the roll axis with a maximum gain of 5.5 db at 2298 mc in the direction of the -Z spacecraft axis (oriented toward the Sun) and a minimum gain of -6 db with respect to circular isotropic over the entire -Z hemisphere. The pattern at 2116 mc is similar.

Since the thrust vector of the midcourse motor is perpendicular to the -Z axis, the Earth can be kept within the -Z hemisphere while the thrust vector is pointed in any arbitrary direction. Thus, the low-gain antenna pattern also meets the requirement for providing coverage during midcourse maneuvers of unrestricted direction.

The high-gain antenna is a 46.0- by 21.2-in. parabolic reflector that is illuminated by a pair of turnstile elements. These elements are arranged so that a right-hand circularly polarized beam is projected with a maximum gain of 23.5 db (at 2298 mc) and a half-power beam width of 13.5 by 7.5 deg. This beam is positioned so that coverage is provided from approximately 90 days from launch until 20 days past encounter. As a result of using this design as opposed to the one-degree-of-freedom antenna that was used on *Mariner II* (Refs. 2, 3), an estimated 50 lb of spacecraft weight was saved by the associated reductions in structure, actuator, control electronics, and power requirements.

With the two antennas and the switching circuit shown in Fig. 2, three transmitting and receiving modes are available:

1. Transmit low gain, receive low gain.
2. Transmit high gain, receive low gain.
3. Transmit high gain, receive high gain.

These modes provide the required coverage during the acquisition, cruise, midcourse maneuver, and encounter phases of the flight. Selection of the proper mode is controlled by programmed CC&S commands or ground commands as a backup.

In addition, two failure mode controls are provided. First, if roll position control is inadvertently lost while the receiver high-gain mode is being used, the loss of the Canopus sensor signal automatically switches the receiver to the low-gain antenna so that command capability can be maintained. Second, if the spacecraft does not receive a signal from Earth at least once between the occurrence of the 66 $\frac{2}{3}$ -hr cyclic pulses, as signified by receiver phase lock, the control unit automatically switches the receiver from one antenna to the other after the receipt of two such pulses. The receiver is subsequently cycled between the antennas once every 66 $\frac{2}{3}$  hr until phase lock is obtained. This later mode control provides partial redundancy for some antenna failure modes.

A summary of the principal radio subsystem transmission and reception parameters is listed in Tables 1 and 2, respectively. The associated Deep Space Net reception and transmission parameters are listed in Tables 3 and 4.

**Table 1. Spacecraft radio transmission parameters (2998 Mc)**

| Parameter                                 | Transponder low-gain channel |                      | Transponder high-gain channel |                      |
|---|------------------------------|----------------------|-------------------------------|----------------------|
|   | Value                        | Tolerance            | Value                         | Tolerance            |
| 1. Total transmitter power <sup>a</sup>   | + 40.0 dbm                   | ± 0.5 db             | + 40.0 dbm                    | ± 0.5 db             |
| 2. Carrier modulation loss <sup>b</sup>   | - 4.1 db                     | + 0.9 db<br>- 1.0 db | - 4.1 db                      | + 0.9 db<br>- 1.0 db |
| 3. Transmission circuit loss <sup>c</sup> | - 1.7 db                     | + 0.2 db<br>- 0.3 db | - 1.3 db                      | + 0.2 db<br>- 0.3 db |
| 4. Spacecraft antenna gain <sup>d</sup>   | + 6.0 db                     | ± 1.8 db             | 23.2 db                       | ± 1.1 db             |

<sup>a</sup> 10 watts nominal output of TWT amplifier.

<sup>b</sup> Based upon modulation indices of (a) data subcarrier = 0.809 rad peak; (b) sync subcarrier = 0.451 rad peak.

<sup>c</sup> Includes all circuitry between the output of the TWT amplifier and the input to the antenna.

<sup>d</sup> Referenced to perfectly circular isotropic, pattern maximum.

**Table 2. Spacecraft radio reception parameters (2116 Mc)**

| Parameter  | Transponder low-gain channel |                    | Transponder high-gain channel |                    |
|--|------------------------------|--------------------|-------------------------------|--------------------|
|  | Value                        | Tolerance          | Value                         | Tolerance          |
| 1. Antenna gain (pattern maximum) <sup>a</sup>                   | +6.5 db                      | ± 1.8 db           | +21.8 db                      | ± 1.1 db           |
| 2. Receiving circuit loss <sup>b</sup>                           | -1.0 db                      | ± 0.2 db           | -0.9 db                       | ± 0.2 db           |
| 3. Effective system noise temperature <sup>c</sup>               | 2700°K                       | +1700°K<br>- 610°K | 2700°K                        | +1700°K<br>- 610°K |
| 4. Carrier APC noise bandwidth (2B <sub>I,O</sub> ) <sup>d</sup> | 20.0 cps                     | —                  | 20.0 cps                      | —                  |
| 5. Carrier threshold SNR in 2B <sub>I,O</sub>                    |                              |                    |                               |                    |
| a. Two-way doppler tracking <sup>e</sup>                         | +3.8 db                      | —                  | +3.8 db                       | —                  |
| b. Command reception   | +8.0 db                      | ± 1.0 db           | +8.0 db                       | ± 1.0 db           |

<sup>a</sup> Referenced to perfectly circular isotropic pattern maximum.

<sup>b</sup> Includes all circuitry between the antenna and the input to the transponder receiver.

<sup>c</sup> Includes contributions due to antenna temperature, circuit losses, and noise figure at input to preselector (10 db  $\begin{smallmatrix} +2 \\ -1 \end{smallmatrix}$  db).

<sup>d</sup> Tolerance included in uncertainty of system noise figure.

<sup>e</sup> +3.8 db SNR is required to limit ground receiver degradation to +2.0 db.

**Table 3. DSN radio reception parameters (2298 Mc)**

| Parameter   | Early flight acquisition |                    | Tracking, diplexed paramp (85-ft dia) |                    | Tracking, diplexed maser (85-ft dia) |                    |
|---|--------------------------|--------------------|---------------------------------------|--------------------|--------------------------------------|--------------------|
|   | Value                    | Tolerance          | Value                                 | Tolerance          | Value                                | Tolerance          |
| 1. Antenna gain <sup>a</sup>                        | 21.9 db                  | ± 1.0 db           | +53.0 db                              | +1.0 db<br>-0.5 db | +53.0 db                             | +1.0 db<br>-0.5 db |
| 2. Circuit loss <sup>b</sup>                        | +0.6 db                  | +0.3 db<br>-0.2 db | +0.3 db                               | ± 0.1 db           | +0.2 db                              | ± 0.1 db           |
| 3. Effective system noise temperature <sup>c</sup>  | 270°K                    | ± 60°K             | 270°K                                 | ± 50°K             | 55°K                                 | ± 10°K             |
| 4. Antenna ellipticity                              | < 1.5 db                 | —                  | +0.7 db                               | ± 0.3 db           | +0.7 db                              | ± 0.3 db           |
| 5. Carrier APC noise bandwidth (2B <sub>I,O</sub> ) | 12 cps                   | +0.0 db<br>-0.5 db | 12 cps                                | +0.0 db<br>-0.5 db | 12 cps                               | +0.0 db<br>-0.5 db |
| 6. Carrier threshold SNR in 2B <sub>I,O</sub>       |                          |                    |                                       |                    |                                      |                    |
| a. One-way doppler tracking                         | 0.0 db                   | —                  | 0.0 db                                | —                  | 0.0 db                               | —                  |
| b. Two-way doppler tracking <sup>d</sup>            | +2.0 db                  | ± 1.0 db           | +2.0 db                               | ± 1.0 db           | +2.0 db                              | ± 1.0 db           |
| c. Telemetry  | +6.0 db                  | —                  | +6.0 db                               | —                  | +6.0 db                              | —                  |

<sup>a</sup> To matched polarization.

<sup>b</sup> Circuit loss includes diplexer, switch, and waveguide losses.

<sup>c</sup> Includes contributions due to antenna zenith temperature, circuit losses, diplexing noise, low-noise amplifier, and follow-on receiver.

<sup>d</sup> When the carrier SNR in 2B<sub>I,O</sub> is +3.8 db on the Earth-to-spacecraft link, +2.0 db is required to overcome the ground receiver degradation.

Table 4. DSN radio transmission parameters (2116 Mc)

| Parameter                                 | Standard Deep Space Station |                    |                           |                    | Nonstandard Deep Space Station |           |
|---|-----------------------------|--------------------|---------------------------|--------------------|--------------------------------|-----------|
|   | Early flight acquisition    |                    | Tracking, diplexed, 10 kw |                    | Horn, nondiplexed, 100 kw      |           |
|   | Value                       | Tolerance          | Value                     | Tolerance          | Value                          | Tolerance |
| 1. Total transmitter power                | +70.0 dbm                   | +0.5 db<br>-0.0 db | +70.0 dbm                 | +0.5 db<br>-0.0 db | +80.0 dbm <sup>d</sup>         | —         |
| 2. Carrier modulation loss <sup>a</sup>   | +3.2 db                     | ±0.3 db            | +3.2 db                   | ±0.3 db            | +3.2 db                        | ±0.3 db   |
| 3. Transmission circuit loss <sup>b</sup> | +0.8 db                     | ±0.3 db            | +0.4 db                   | ±0.1 db            | —                              | —         |
| 4. Antenna gain <sup>c</sup>              | 19.7 db                     | ±1.0 db            | +51.0 db                  | +1.0 db<br>-0.5 db | +53.0 db                       | ±1.0 db   |
| 5. Antenna ellipticity                    | 1.4 db                      | ±0.2 db            | +1.0 db                   | ±0.5 db            | +0.5 db                        | ±0.3 db   |

<sup>a</sup> Based upon carrier modulation indices of (a) data subcarrier = 0.717 rad peak; (b) sync subcarrier = 0.655 rad peak.

<sup>b</sup> Circuit loss includes diplexer, switch, and waveguide losses.

<sup>c</sup> To matched polarization.

<sup>d</sup> Measured at input to 85-ft antenna turnstile junction.

### III. TELEMETRY SUBSYSTEM

The principal functions of the telemetry subsystem on the spacecraft are to time-multiplex engineering and scientific data samples and to encode them for efficient modulation of the spacecraft-to-Earth RF carrier. The subsystem is specifically required to:

1. Transduce engineering parameters into electrical signals.
2. Time-multiplex (commutate) engineering and scientific measurement signals.
3. Convert engineering data samples to binary words.
4. Store digitally encoded video data.
5. Phase-shift-key a subcarrier with the binary signal.
6. Generate a cyclic, binary, pseudorandom sequence for use in synchronizing the encoding and decoding of the telemetry data.

7. Phase-shift-key a second subcarrier with the sync code.
8. Combine the two subcarriers into a composite telemetry signal.

Figure 7 shows the arrangement of the elements that perform these functions.

The basic timing for the subsystem is derived from the 2400-cps spacecraft power frequency which is divided down to provide two subcarrier frequencies, one for data and one sync. The frequency divider is arranged to provide two data transmission (bit) rates,  $33\frac{1}{3}$  and  $8\frac{1}{3}$  bits per sec. While the  $33\frac{1}{3}$ -bps rate is used during preflight checkout and the early flight phases up through a first midcourse maneuver, the  $8\frac{1}{3}$ -bps rate is used for the remainder of the flight. In-flight selection of the data rate is controlled by ground command and CC&S command. Either rate can be selected by ground command,



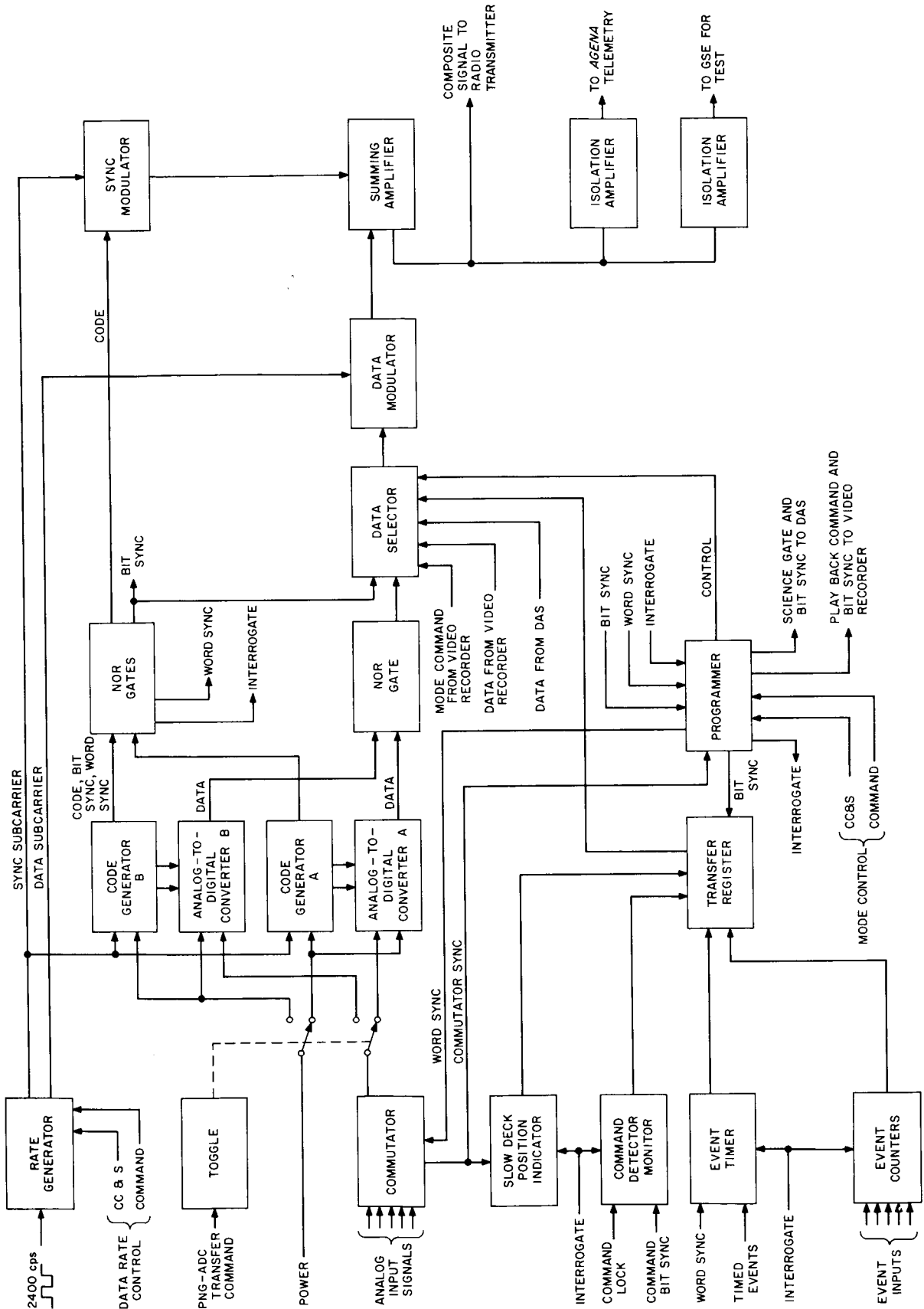

Fig. 7. Spacecraft telemetry subsystem

but the CC&S selects only the 8 1/3-bps rate 192 days before encounter. The CC&S control is to insure that the 8 1/3-bps rate is used at encounter in the event that command capability is lost.

The squarewave sync subcarrier drives a redundant pair of pseudorandom code generators which generate a cyclic 63-bit code. A set of word gates, in turn, generates bit and word sync pulses that are used to synchronize (1) the stepping of the commutator, (2) the analog-to-digital converters, (3) the readout of data from the data automation system, (4) the readout of the event registers and timers, and (5) the playback of the stored video data. The word sync pulses occur once per cycle of the code, while the data bit sync pulses occur once every 9 code bits, or 7 times per code cycle. Thus, each data word is seven data bits long.

In order to convey the bit and word sync timing to the ground stations for use in synchronous demodulation of the telemetry subcarrier, the code also phase-shift-keys the sync subcarrier. The resulting composite telemetry signal that modulates the spacecraft-to-Earth carrier is given by Eq. (4),

$$D(t) = V_a \left[ 1.79 d \left( \frac{2 f_a t}{9} \right) \oplus a (4 f_a t) + X \left( \frac{f_a t}{2} \right) \oplus a (2 f_a t) \right] \tag{4}$$

where

$V_a$  is the amplitude of the complex four level wave

$d \left( \frac{2 f_a t}{9} \right)$  is the binary telemetry data of amplitude  $\pm 1$  and bit rate  $2/9 f_a$

$a(ft)$  is a symmetrical squarewave of amplitude  $\pm 1$  and frequency  $f$

$X \left( \frac{f_a t}{2} \right)$  is a cyclic, binary, pseudorandom sequence of amplitude  $\pm 1$ , length 63 bits, and bit rate  $f_a/2$

$\oplus$  represents modulo 2 addition.

At the ground station, a local model of the code is phase-locked to the received code. Word gates identical to those in the spacecraft code generators then produce accurate bit and word sync pulse trains. For a detailed discussion of the technique, the reader is referred to References 6, 7, and 8.

Analog engineering measurements are sampled by a solid-state commutator that provides 100 channels; 90 of the channels are used for measurements, while 10 are used for synchronization points and subcommutation. As shown in Fig. 8, these channels are divided among 10 decks of 10 channels each and are arranged to provide 3 sampling rates. The resulting times between samples of each measurement for each transmission rate are listed in Table 5.

The pulse-amplitude-modulated output of the commutator is fed to two analog-to-digital converters, which convert the data samples to serial 7-bit words by a successive approximation technique. The output of the converter forms one of four data sources that comprise the telemetry modes.

**Table 5. Time between samples**

| Deck rate |         | Mode 1              |                      | Mode 2               |                        |
|-----------|---------|---------------------|----------------------|----------------------|------------------------|
|           |         | 33 1/3 bps          | 8 1/3 bps            | 33 1/3 bps           | 8 1/3 bps              |
| 1         | High    | 4.2 sec             | 16.8 sec             | 12.6 sec             | 50.4 sec               |
| 2         | Medium  | 42.0 sec            | 168 sec<br>(2.8 min) | 126 sec<br>(2.1 min) | 504 sec<br>(8.4 min)   |
|           | Low     | 420 sec<br>(7 min)  | 1680 sec<br>(28 min) | 1260 sec<br>(21 min) | 5040 sec<br>(1.4 hr)   |
| 3         | Low-low | 840 sec<br>(14 min) | 3360 sec<br>(56 min) | 2520 sec<br>(42 min) | 10,080 sec<br>(2.8 hr) |

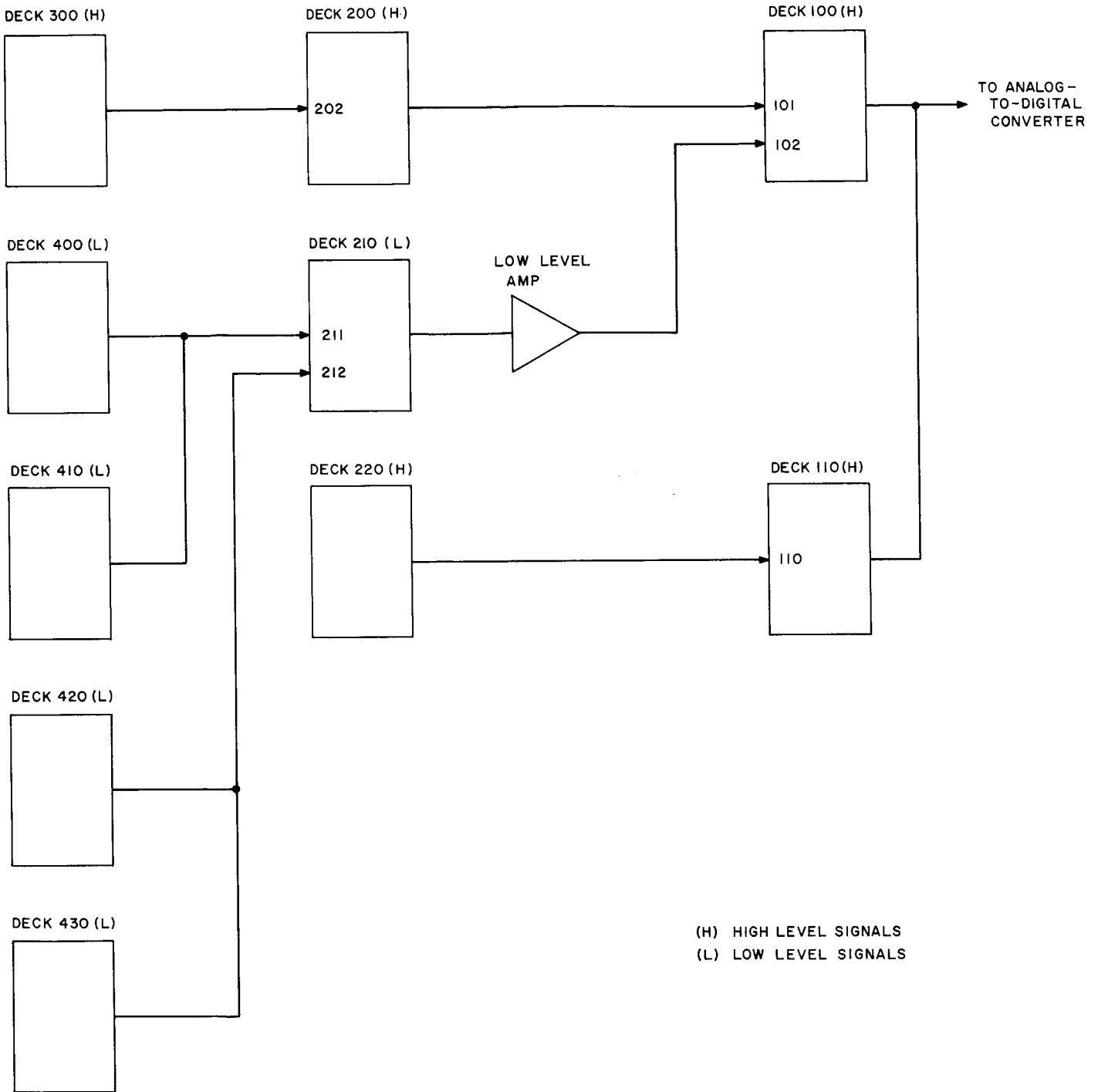

Fig. 8. Commutator, functional diagram

Four modes of data transmission are provided for: (1) engineering data, (2) engineering and science data, (3) science data, and (4) stored video data and engineering data. In the first mode, only engineering data from the commutator, event register, event timer, and command

monitor is transmitted, and it is intended primarily for maneuver and checkout phases. In the second mode, a combination of engineering and science data is transmitted in an alternating sequence of 140 engineering data bits followed by 280 science data bits. This mode is

intended for most of the cruise phases. In the third mode, only science data is transmitted as received from the data automation system. This mode is designed for use at planet encounter. In the fourth mode, stored video and engineering data is transmitted in alternating periods of approximately 9 and 1.5 hr, respectively. This mode provides for readout of the video data taken during encounter and periodic monitoring of the spacecraft performance after encounter.

Event-type signals that signify the occurrence of events such as motor-start, receipt-of-command, or solar-panels-open are accumulated as they occur in four separate registers. Each register accumulates different types of events as shown in Table 6 and holds up to 8 counts before recycling. The registers are sampled in pairs at the high commutation rate in synchronism with the commutator, so that the state or count of two registers is conveyed by one 7-bit word.

An event timer measures the duration of certain events, such as the midcourse motor firing duration, by dividing the word sync rate by 2 and accumulating the number of pulses that occur between the start and end of the event. This number is sampled at the medium rate also in synchronism with the commutator.

During Mars encounter, a television subsystem which operates under DAS control periodically generates video data in binary form. This data and the mode 3 instrument data generated at an effective rate of 10.7K bps are organized in 516,168 bit frames, of which 504,400 are TV-related. Since this data rate greatly exceeds the 8½-

bps radio transmission capability at encounter, a data storage subsystem (as shown in Fig. 9) holds the data for postencounter readout.

Data storage is accomplished by an endless-loop tape recorder. This machine records binary data and sync pulses on two tracks, filling one track at a time on each of two consecutive tape cycles. Recording is started and stopped by control signals from the data automation system to coincide with the encounter data frames. In order to prevent overrecording after the two tracks are filled the first time, end-of-tape signals automatically stop the recorder after the second complete tape pass. The tape is then in the correct position for subsequent playback.

Playback is at the 8½-bps transmission rate and is synchronous with the telemetry bit sync pulses. This is accomplished by an automatic phase control servo which controls the tape speed such that the recorded bit sync pulses are kept in phase with the telemetry bit sync pulses. By this means the pseudorandom sync signal allows synchronous demodulation of the recorded data at the ground stations.

In conjunction with the starting and stopping of the recorder during the record cycles, approximately 3 to 5 ft of tape are used while the machine accelerates and decelerates. No data is recorded on these segments. During the continuous playback, these blank spots provide approximately 1.5 hr in which spacecraft engineering data is inserted for periodic monitoring of postencounter spacecraft performance. Control of this alternation between the recorded and engineering data is provided by a circuit that senses the presence or absence of data on the tape. Table 7 summarizes the characteristics of the tape machine.

As with the radio subsystem, limited redundancy has been incorporated in the telemetry subsystem for increased reliability. This redundancy is in the form of two pseudorandom code generator analog-to-digital converter

**Table 6. Registered events**

| Events         |   |
|----------------|---|
| Channel 1..... | Pyrotechnics current pulse<br>Gyro turn-on<br>Solar panel 1 open                                  |
| Channel 2..... | CC&S events<br>Solar panel 2 open   |
| Channel 3..... | Pyrotechnic arm<br>Pyrotechnic current pulse<br>Solar panel 3 open<br>Recorder end of tape signal |
| Channel 4..... | Ground command events<br>Sun acquired<br>Solar panel 4 open<br>Scan platform unlatched            |

**Table 7. Video storage characteristics**

|                                      |                             |
|--------------------------------------|-----------------------------|
| 1. Record rate.....                  | 10,700 bps                  |
| 2. Playback rate (synchronous) ..... | 8½ bps                      |
| 3. Storage capacity.....             | 5.24 × 10 <sup>9</sup> bits |
| 4. Number of tracks.....             | 2                           |
| 5. Type of tape machine.....         | Endless loop                |

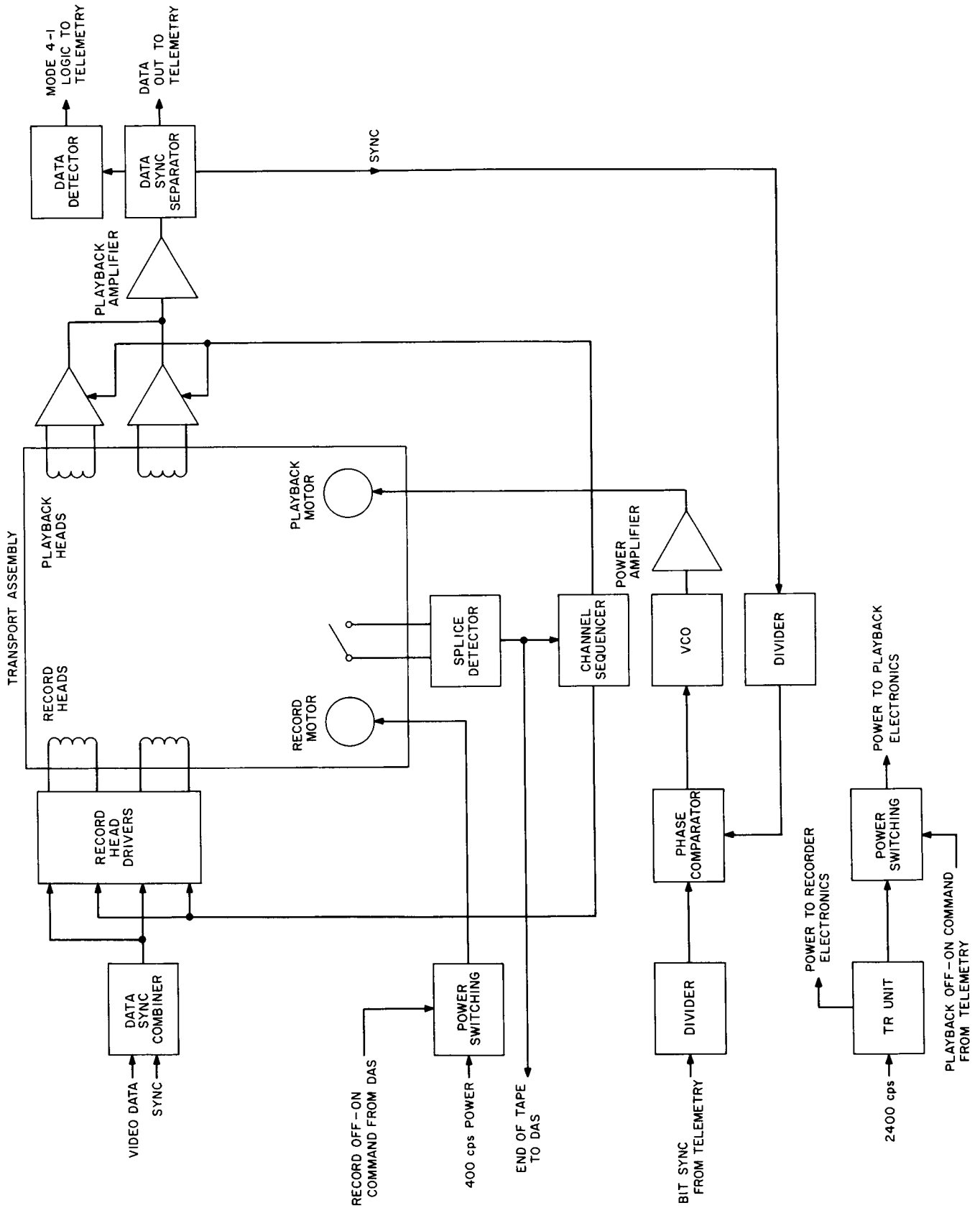

Fig. 9. Video magnetic tape recorder

pairs which operate with parallel inputs and logical "or" coupled outputs. Only one pair operates at a time, and this pair is selected by ground command.

In addition, the commutator sequencer has been designed so that many of the possible failure modes result in a modification or "short counting" of the sequence rather than a complete stoppage. The number of channels that would be lost for a given failure depend on the location of the failed component so that a varying degree of partial success can exist. For example, a short count in a low-rate deck would not affect the higher rate channels, while a short count in a high-rate deck could bypass a large number of low-rate channels.

Finally, redundant components such as resistors, diodes, and capacitors have been employed in the power transformer-rectifier unit.

Table 8 lists the principal telemetry subsystem parameters.

**Table 8. Telemetry parameters**

|  |  |
|--|--|
| 1. Type of encoding . . . . .                    | Sampled data, digital phase shift keying with PN sync          |
| 2. Channel requirements                          |  |
| Engineering measurements . . . . .               | 90   |
| Event counters . . . . .                         | 4  |
| 3. Word length . . . . .                         | 7 bits   |
| 4. Transmission rates . . . . .                  | 33½, 8½ bps  |
| 5. Word error probability                        |  |
| at threshold . . . . .                           | 1 word in 28 ( $P_e^b = 5 \times 10^{-3}$ )                    |
| 6. Required ST/N/B for bit error                 |  |
| probability $P_e^b = 5 \times 10^{-3}$ . . . . . | 7.6 db—cps/bps $\pm 0.7$ db                                    |
| 7. Data channel modulation loss . . . . .        | -4.6 db $\pm 0.6$ db   |
| 8. Sync channel threshold S/(N/B) . . . . .      | 11.0 db * cps $\pm 0.5$ db                                     |
| 9. Sync channel modulation loss . . . . .        | -10.5 db $\begin{matrix} +0.2 \text{ db} \\ -0.3 \end{matrix}$ |

### IV. COMMAND SUBSYSTEM

Commands are transmitted from DSN ground stations to the spacecraft by two subcarriers which phase-modulate the Earth-to-spacecraft RF carrier. One of the subcarriers is phase-shift-keyed by serial binary command words, and the other is phase-shift-keyed by a pseudorandom sync code in a manner similar to that used for telemetry data transmission.

The command subsystem is required to detect and decode the command words, of which there are two types, direct commands which result in selected switch closures and quantitative commands which convey a magnitude and polarity for spacecraft maneuvers.

Initial acquisition is achieved by slightly offsetting the frequency of the clock at the ground stations from the average static frequency of the loop VCO. Under this condition, the local code is slowly shifted in phase with respect to the received code until the phases match. The frequency difference is made small enough so that the APC loop receives sufficient signal to acquire phase lock and the acquisition is complete.

Outputs from the command subsystem include the direct command switch closures, the quantitative command bits, bit sync pulses, alert pulses for the CC&S and several telemetry signals. In the case of both direct and quantitative command output circuits, complete DC isolation is maintained from the interfacing spacecraft subsystems.

As an aid to acquisition and inflight performance monitoring, the sync channel VCO frequency and in-lock signals are telemetered. For this purpose, a special

counter converts the VCO frequency to a binary number which is periodically sampled by the telemetry system. Table 9 lists the principal command subsystem parameters.

**Table 9. Command parameters**

|   |                       |
|---|-----------------------|
| 1. Number of commands   |                       |
| Discrete .....  | 29                    |
| Quantitative .....  | 1 (3)                 |
| 2. Modulation type..... Digital PSK with PN sync                                    |                       |
| 3. Word length..... 26 bits   |                       |
| 4. Transmission rate..... 1 bps   |                       |
| 5. Command threshold definition   |                       |
| Probability of correctly executing a discrete command (DC) in one attempt.....      | >0.7                  |
| Probability of completely executing a quantitative command (QC) in one attempt..... | >0.5                  |
| Probability of a bit error in a completely executed QC.....                         | $<2 \times 10^{-4}$   |
| Probability of a false QC or DC being executed when another command is sent.....    | $<2 \times 10^{-9}$   |
| 6. Required carrier SNR in 20-cps bandwidth at command threshold.....               |                       |
|   | +8.0 db $\pm$ 1.0 db  |
| 7. Required command channel ST/N/B at threshold.....                                |                       |
|   | +15.7 db $\pm$ 1.0 db |
| 8. Command channel modulation loss.....   |                       |
|   | +8.5 db $\pm$ 0.6 db  |
| 9. Required sync channel SNR at threshold.....                                      |                       |
|   | +15.7 db $\pm$ 1.0 db |
| 10. Sync channel effective noise bandwidth.....                                     |                       |
|   | +2.0 cps $\pm$ 0.8 db |
| 11. Sync channel modulation loss.....   |                       |
|   | +5.5 db $\pm$ 0.5 db  |

### V. PERFORMANCE

The telecommunication system is required to provide tracking, telemetry, and command performance from launch to 20 days past encounter, including all of the intermediate phases. In order to reasonably assure this capability, it was desired to choose the system parameters so that the nominal received signal levels always exceeded the threshold signal levels by at least the linear sum (in db) of the adverse tolerances (Ref. 10). This criterion has been met for all functions and flight phases, except for the telemetry for a period of 10 to 26 days, depending on the launch date.

Figure 10 illustrates, for a typical trajectory, the nominal received carrier level for the spacecraft-to-Earth channel vs. time-from-launch. These curves were computed using the parameters listed in Tables 1 and 3 for the standard Deep Space Station with a diplexed tracking antenna. The variations are due to both the increasing range and the variable antenna gains, and it is apparent where the performance of the low-gain antenna leaves off and that of the high-gain antenna takes over.

For the diplexed tracking feed and maser ground station configuration, the nominal threshold carrier level for telemetry is  $-164.4$  dbm at  $8\frac{1}{2}$ -bps. A comparison between this value, the nominal carrier levels, and the system tolerances (Fig. 11) shows that the design criterion has been met over most of the flight and the extent to which it has not been met at the transition region. In the transition region, the telemetry performance may be marginal.

This situation is a result of the antenna position compromise that had to be made between midflight performance and postencounter performance with a relatively simple antenna design. Midflight performance was sacrificed to meet the 20-day postencounter requirement. Since the nominal carrier level is never less than the nominal threshold level, it is considered to be a reasonable compromise.

The nominal received carrier levels for the Earth-to-spacecraft channel are shown in Fig. 12. Since the same spacecraft antennas are used for transmitting and

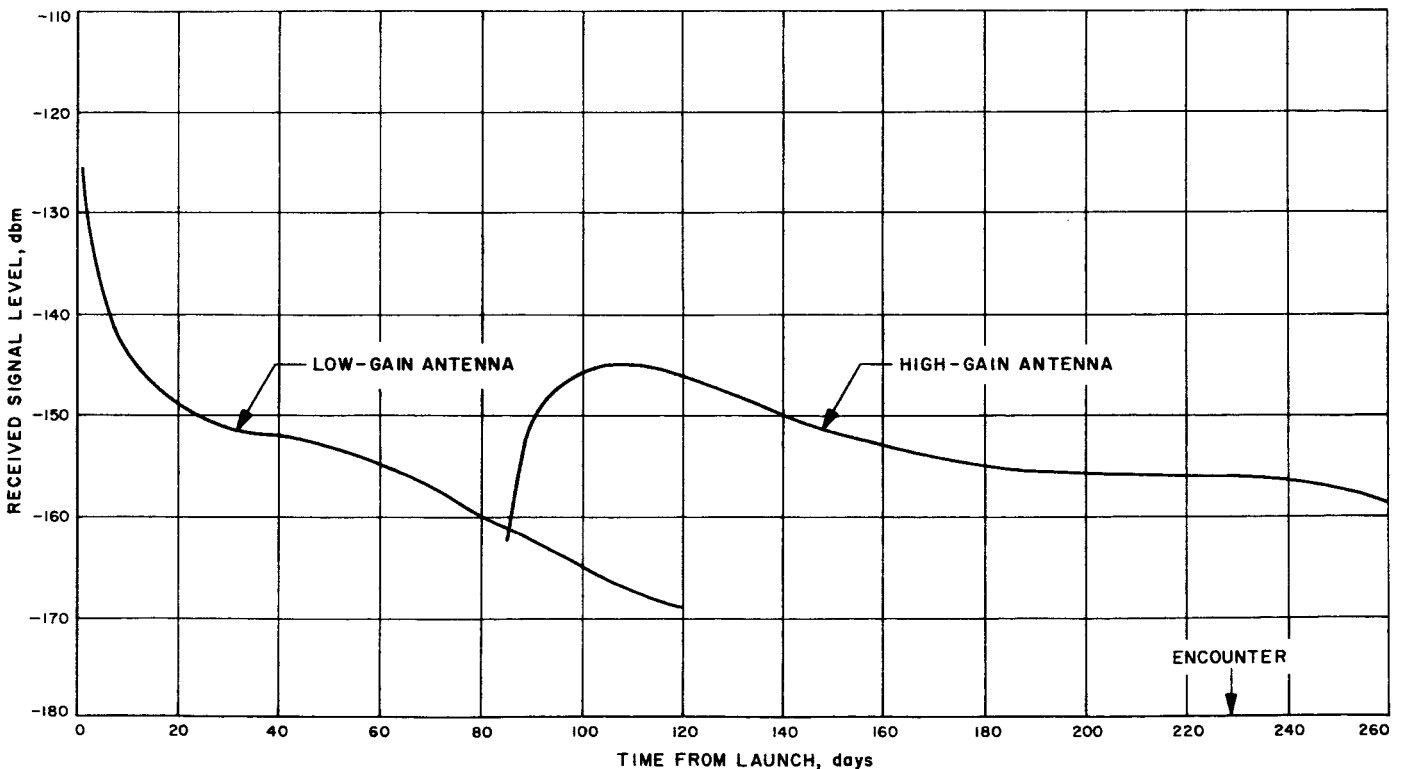

Fig. 10. Received signal level vs time, spacecraft to Earth



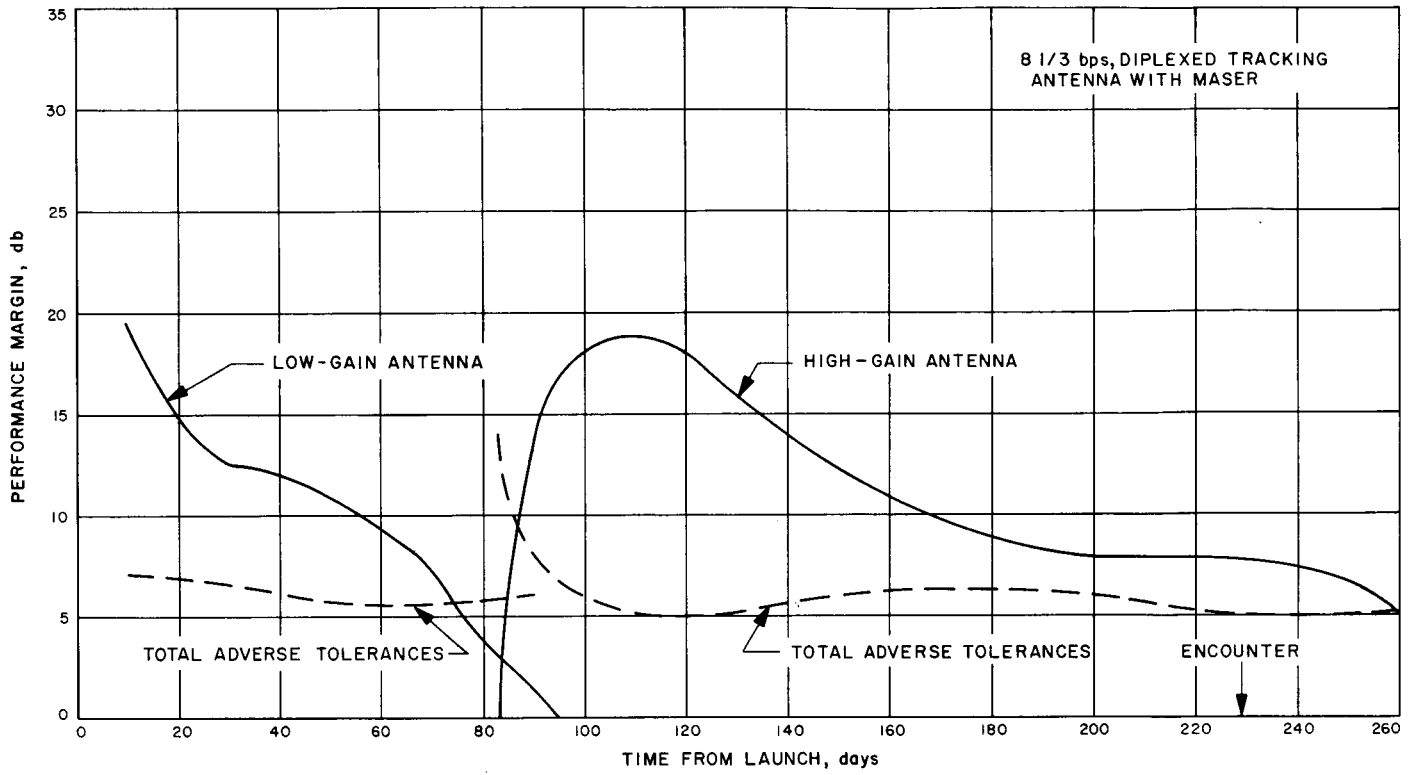

Fig. 11. Telemetry performance margin vs time

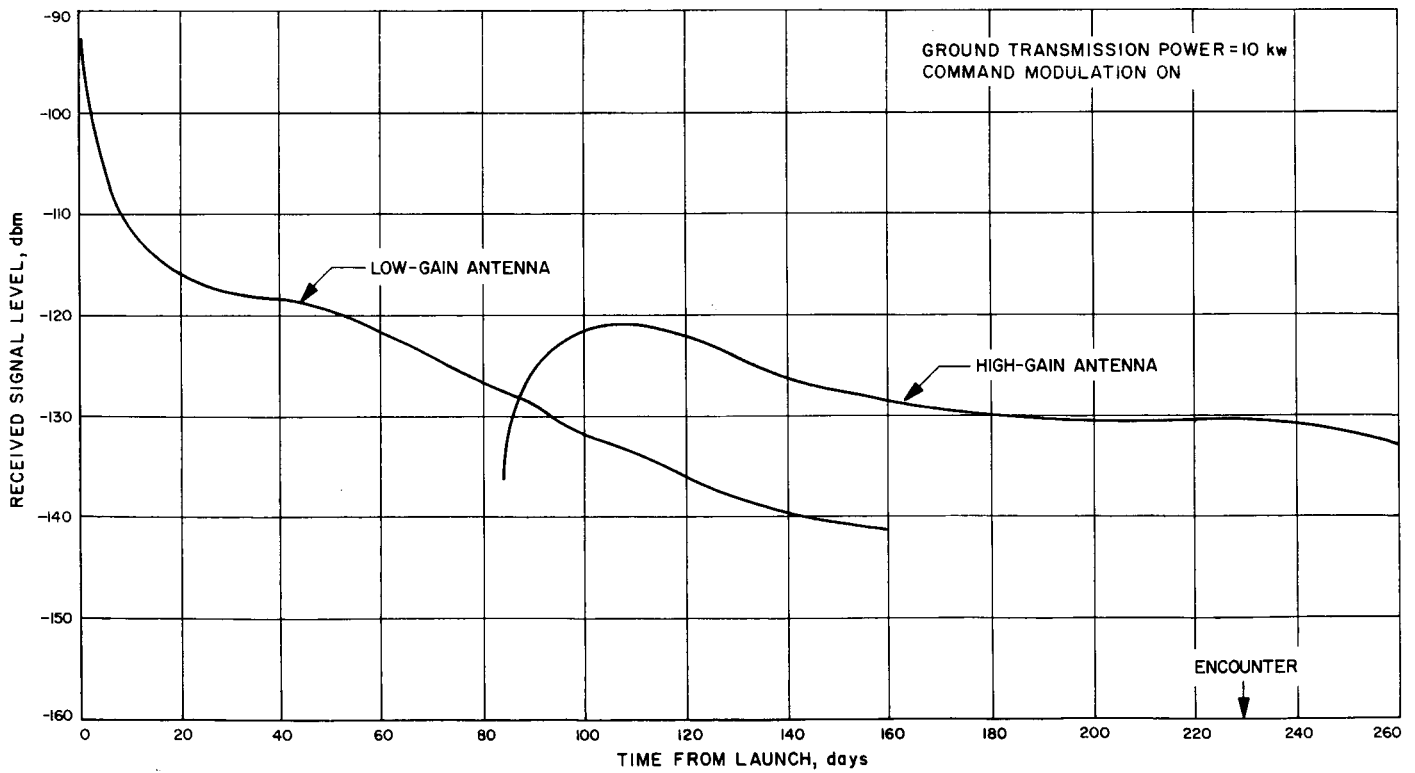

Fig. 12. Received signal level vs time, Earth to spacecraft

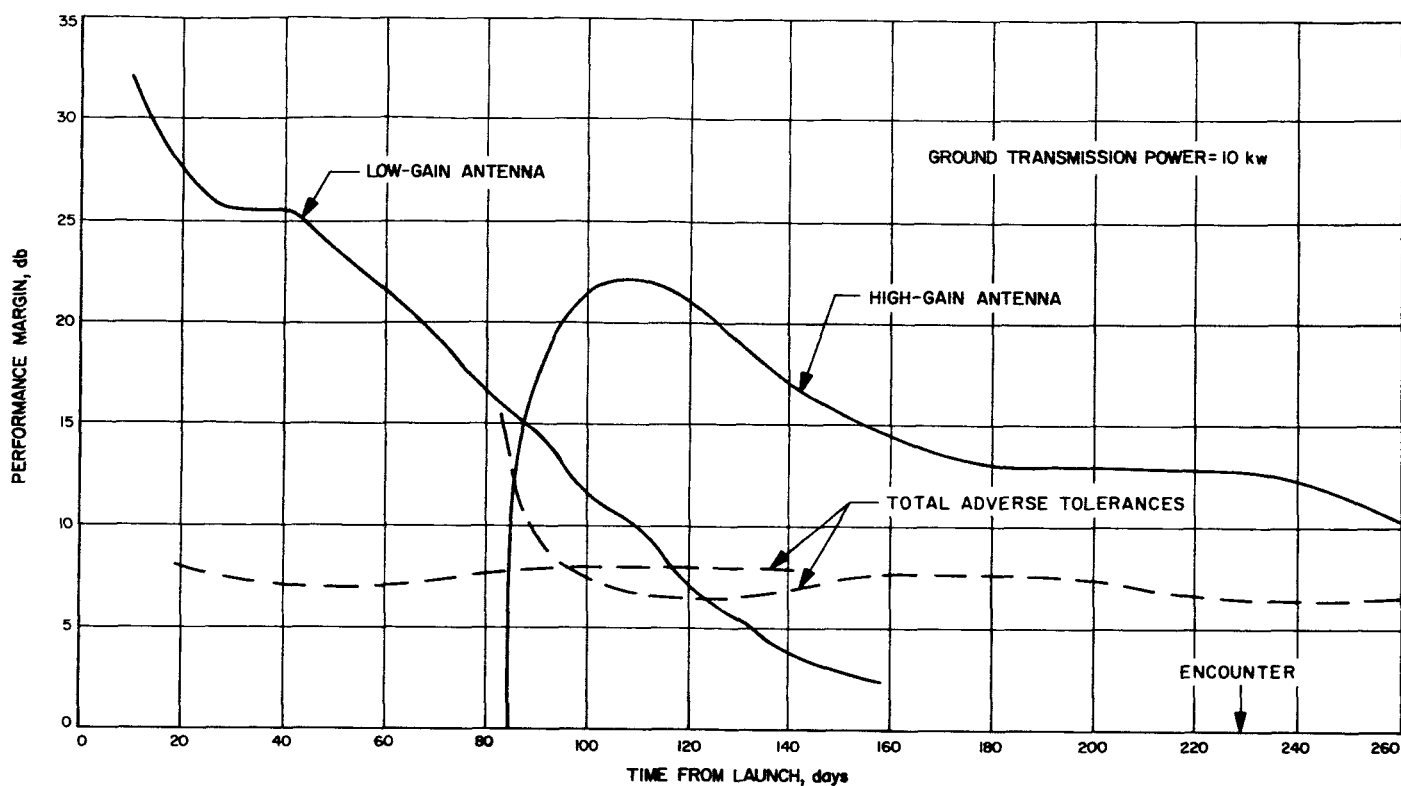

Fig. 13. Command performance margin vs time

receiving, both up and down channels exhibit similar time variations. A comparison between the command threshold carrier level of  $-143.3$  dbm, the nominal re-

ceived level and the system tolerances (Fig. 13) shows that the design criterion for command has been met for all flight phases.

## CONCLUSION

The *Mariner* Mars Mission for 1964 required a telecommunication system to provide tracking, telemetry, and command capabilities over communication distances up to 260 million km and which would operate for approximately 8 months in an interplanetary space

environment. The design that has been described is an extension and modification of well proven techniques, where the modifications included required improvements in performance and limited redundancy to improve reliability.

## REFERENCES

1. *System Capabilities and Development Schedule of the Deep Space Instrumentation Facility*, Technical Memorandum No. 33-83, Jet Propulsion Laboratory, Pasadena, California, April 24, 1964.
2. *Mariner: Mission to Venus* (prepared by the Staff, JPL), McGraw Hill Book Co., Inc., New York, 1963.
3. Bryden, J. N., *Mariner (Venus '62) Flight Telecommunication System*, Technical Report No. 32-377, Jet Propulsion Laboratory, Pasadena, January 15, 1963.
4. *Space Programs Summary No. 37-23, Volume II*, Jet Propulsion Laboratory, Pasadena, September 30, 1963.
5. *Space Programs Summary No. 37-24, Volume VI*, Jet Propulsion Laboratory, Pasadena, December 31, 1963, p. 71.
6. Martin, B. D., *The Mariner Planetary Communication System Design*, Technical Report No. 32-85 (Rev. 1), Jet Propulsion Laboratory, May 15, 1961.
7. Springett, J. C., *Command Techniques for the Remote Control of Interplanetary Spacecraft*, Technical Report No. 32-314, Jet Propulsion Laboratory, Pasadena, August 1, 1962.
8. Springett, J. C., *Pseudo Random Coding for Bit and Work Synchronization of PSK Data Transmission Systems*, International Telemetry Conference, London, 1963.
9. Mathison, R. P., *Tracking Techniques for Interplanetary Spacecraft*, Technical Report No. 32-284, Jet Propulsion Laboratory, Pasadena, August 1, 1962.
10. Mathison, R. P., "Spacecraft Telecommunications System Design," 1963 Yearbook for the WGLR Conference in Munich, October 1963.

## ACKNOWLEDGMENT

The system and techniques described herein have been developed by the efforts not only of the author but of many other members of the Jet Propulsion Laboratory Telecommunications Division. The report was prepared for and presented at the 1965 National Winter Convention on Military Electronics.