

CS13

COMPUTATION OF THE PSEUDOINVERSE OF A MATRIX OF UNKNOWN RANK

BY

VICTOR PEREYRA and J. B. ROSEN

GPO PRICE \$	_____
OTS PRICE(S) \$	_____
Hard copy (HC)	2.10
Microfiche (MF)	25.

TECHNICAL REPORT CS13
SEPTEMBER 1, 1964

FACILITY FORM 602

N65-27058

(ACCESSION NUMBER)

29

(PAGES)

CR 63506

(NASA CR OR TMX OR AD NUMBER)

(THRU)

1

(CODE)

19

(CATEGORY)

DDC
NOV 23 1964
DDC-IRA C

COMPUTER SCIENCE DIVISION
School of Humanities and Sciences
STANFORD UNIVERSITY



COMPUTATION OF THE PSEUDOINVERSE OF

A MATRIX OF UNKNOWN RANK **/

by

Victor Pereyra^{*/} and J. B. Rosen

Abstract

27058

A program is described which computes the pseudoinverse, and other related quantities, of an $m \times n$ matrix A of unknown rank. The program obtains least square solutions to singular and/or inconsistent linear systems $Ax = B$, where $m \leq n$ or $m > n$ and the rank of A may be less than $\min(m,n)$. A complete description of the program and its use is given, including computational experience on a variety of problems.

Author

^{*/} On leave from Dept. of Mathematics and Computation Center, Buenos Aires University, Argentina.

**/

Reproduction in Whole or in part is Permitted for any Purpose of the United States Government. Prepared under NASA Grant Ns G 565 at Stanford University. Stanford California

I. Introduction.

A method for the computation of the pseudoinverse, and other related quantities, corresponding to an $m \times n$ matrix A of unknown rank r , has recently been described [5]. The method determines the pseudoinverse A^+ of A and a related matrix $A^\#$. The pseudoinverse has the property that given the linear system $Ax = b$, the solution $x_m = A^+b$ satisfies $\|Ax_m - b\| \leq \|Ax - b\|$ for all x , and $\|x_m\| \leq \|x\|$ for all x such that $\|Ax_m - b\| = \|Ax - b\|$. The minimum basic solution $x_b = A^\#b$ has the property that $\|Ax_b - b\| \leq \|Ax - b\|$ for all x , and x_b has at most r non-zero elements.

The computational difficulty for this problem arises primarily because the rank r is not known. In particular, it may be difficult to assign the correct rank if one or more of the singular values of A are small but non-zero [3]. Several other recent papers [1], [2], [4], on the computation of the pseudoinverse have not considered this important practical question.

The approach used here to handle this difficulty can be summarized as follows. The desired matrices $A^\#$ and A^+ are formed from a matrix B , which consists of linearly independent columns selected from A .

We would like to determine B so that it spans the same space as A , in which case B will contain r columns. Suppose we have a matrix B_q with q linearly independent columns selected from A , (where $q < r$) and the corresponding approximation A_q^+ to A^+ . Adding another linearly independent column of A to B_q , giving B_{q+1} , should give an improved approximation A_{q+1}^+ to the pseudoinverse. However, due to roundoff error in the calculation it may turn out for an ill-conditioned system that the new approximation is actually worse in the sense that $\|AA_{q+1}^+ - I\| > \|AA_q^+ - I\|$. Such a test is made in the pseudoinverse determination with the result that the effective rank of A (the number of columns in B) is the maximum possible consistent with minimizing the error $\|AA^+ - I\|$.

A closely related aspect of the method used here to compute the pseudoinverse is what might be called its "smoothing" property. In many practical situations one would like to obtain a solution to a linear system which is stable in the sense that small changes in the matrix elements do not cause large changes in the solution vector. In general, the solution $x = A^+b$, where A^+ is the true pseudoinverse, will not behave smoothly. In fact, the norm of x will increase without bound as a singular value of A approaches zero. This difficulty can be eliminated by imposing a predetermined upper bound on the norm of $(B'B)^{-1}$. This is accomplished by estimating the effect of adding a new column of A to B_q and only adding this new column to B_q if it does not cause any element of A_{q+1}^+ to exceed the bound. Details of this selection procedure and the manner in which it depends on the choice of the bound SUPER is discussed in the next section.

In Section 3 the use of the Algol program, written to perform this algorithm, is described and suggested values for the input parameters are given. The program use is illustrated by means of a sample problem. A large number of problems have been solved using this program.

Several different kinds of tests have been performed:

- a) Very ill-conditioned matrices like the segments of the Hilbert matrix [6] have given a clear example of the smoothing property of the method.
- b) Random rectangular matrices of random sizes have been generated and the pseudoinverse have been computed. The sizes were allowed to vary between 1 and 25. In all the cases the results were satisfactory.
- c) Same as in b) but with random ranks. In every case the rank was correctly determined by the program.
- d) Random matrices of specified size covering a range of values of \underline{m} and \underline{n} were run in order to obtain time estimates for different size problems.
- e) A number of least-square problems, i.e., with $m \gg n$ and only one right-hand side.
- f) A variety of matrices for which an independent check on the accuracy of the solution was available.

Tests b) through f) showed that in reasonable problems in which the rank is well determined the program will work very well, while a) has shown that in very ill-conditioned cases the smoothing property of the method is effective.

These test results are discussed more fully in Section 4. The notation used in [5] will also be followed here.

Details of storage requirements are given in Section 5.

A copy of the program appears in the Appendix.

II. Program Description.

The method used to compute $A^\#$ and A^+ from B is essentially that given in Section 2 of [5]. For convenience we will repeat the key relations here. The pseudoinverse of the $m \times r$ matrix B of rank r is given by

$$(2.1) \quad B^+ = (B'B)^{-1} B'$$

The non-zero rows of the $n \times m$ matrix $A^\#$ then consists of the corresponding rows of B^+ . An $r \times n$ matrix of rank r is also obtained from B^+ according to

$$(2.2) \quad C = B^+A$$

Note that, if B contains all the independent columns of A , then $A = BC$. Finally, A^+ is obtained from C and B^+ by

$$(2.3) \quad A^+ = C'(CC')^{-1} B^+$$

The determination of B is based on the algorithm of Section 3 in [5], using the more sophisticated selection procedure described below.

The program consists essentially of two parts. One part has all the input-output and the other is a PROCEDURE called PSEUDOINVER which may also be used separately as a part of other programs. The program solves the matricial problem,

$$(2.4) \quad AX = \text{RHS}$$

where RHS is a matrix containing several right hand sides.

a) The first part of PSEUDOINVER normalizes the matrix A by scaling each column so that its Euclidean norm is equal to one. The normalization constants are saved in order to get back to the original problem.

The search for independent columns of A is then made to determine the matrix B , according to the formulas described in section 3 of [5]. At this stage, the condition for a vector to be accepted as independent of the ones already included in the basis is that α , the square of the norm of the projection on the orthogonal subspace to that basis, be less than a quantity $ORTP$, which is an input parameter. Later we will discuss the appropriate choice of $ORTP$ and the other parameters appearing in the program.

As the columns chosen in this fashion might not necessarily be the first columns of A , a record is kept of the column number of the accepted vectors.

After all the columns have been inspected two situations can arise; either all the n columns of A have been accepted or some have been rejected. In the first case we have finished and the computations indicated at the beginning of this section are performed to get A^+ , $A^\#$, X_b and X_m . Other computed quantities are the residuals, $NXM = \|AX_m - RHS\|$ $NXB = \|AX_b - RHS\|$ corresponding to X_m and X_b , and $EST = \|BC - A\|$.

EST would be zero if the computation were performed exactly; in general EST will be very small for well-conditioned matrices and will increase with the ill-conditioning or if an almost dependent column is added to B .

If only $q < n$ columns of A are selected for inclusion in B then the basis thus constructed is called B_q and the second part of PSEUDOINVER is called.

b) The projections on the subspace orthogonal to B_q are computed for all the rejected columns. The Euclidean norm of each projection is computed,

$$(2.5) \quad \alpha_j = \|(I - B_q B_q^+) a_j\|^2$$

and the column corresponding to the maximum α_j (the most independent one) is stored in SAV.

c) A test is now performed which is based upon an estimation of the norm that $(B'_{q+1} B_{q+1})^{-1}$ would have if we were to include SAV in the basis. The norm used is $\|A\| = \max_i \sum_{j=1}^n |a_{ij}|$ and the estimate is derived from the formula,

$$(2.6) \quad (B'_{q+1} B_{q+1})^{-1} = \left(\begin{array}{c|c} (B'_q B_q)^{-1} & 0 \\ \hline 0 & 0 \end{array} \right) + \alpha_{q+1}^{-1} \begin{pmatrix} u_q \\ -1 \end{pmatrix} (u'_q \mid -1)$$

where $u_q = B_q^+ \text{SAV}$ and α_{q+1} is the square of the norm of the projection of SAV on the orthogonal subspace to that spanned by B_q . Then

$$\|(B'_{q+1} B_{q+1})\| \leq \text{ESTIM} = \|(B'_q B_q)^{-1}\| + \alpha_{q+1}^{-1} (1 + \sqrt{q})$$

If ESTIM is larger than SUPER (an input parameter) then SAV is rejected and B_q is taken as the final B .

This test avoids large elements in the pseudoinverse and gives the smoothing property discussed in the introduction.

d) If the test in c) is passed then the PROCEDURE GARBG, which computes all the matrices and quantities mentioned at the beginning of this section, is called and a second test is made. GARBG is used again, now with the basis B_q plus the column SAV. The test consists in comparing the values of $\|AX_m - \text{RHS}\|$, $\|AX_p - \text{RHS}\|$ and $\|BC - A\|$ obtained with one basis, with the corresponding ones obtained with the incremented basis. If all these values for B_{q+1} are smaller than for B_q then SAV is definitely

accepted. After shifting all the useful quantities, part (b) is repeated for the new basis B_{q+1} and so on, until either an exit is provided for one of the tests or the columns of A are exhausted. All the scalar products are performed in double precision. The block diagram in Fig. I shows the most essential parts of the program.

It is worth noting that this strategy has been dictated by the problem itself and achieves the best numerical pseudoinverse possible using the method of [5] and taking into account the numerical roundoff error of the computer being used. This strategy takes advantage of the step by step algorithm for determining B , and constructs an independent basis, the degree of independence being determined by the parameter ORTP. By picking the most independent vector among the remaining ones, and checking to see if this decreases the residuals (by taking this vector in the basis) we are answering in a direct manner the two questions: how many columns of A do we need to minimize the residual? and, among all the possible sets of independent columns, which set gives the best representation of the pseudoinverse?

Fig. 1 - BLOCK DIAGRAM

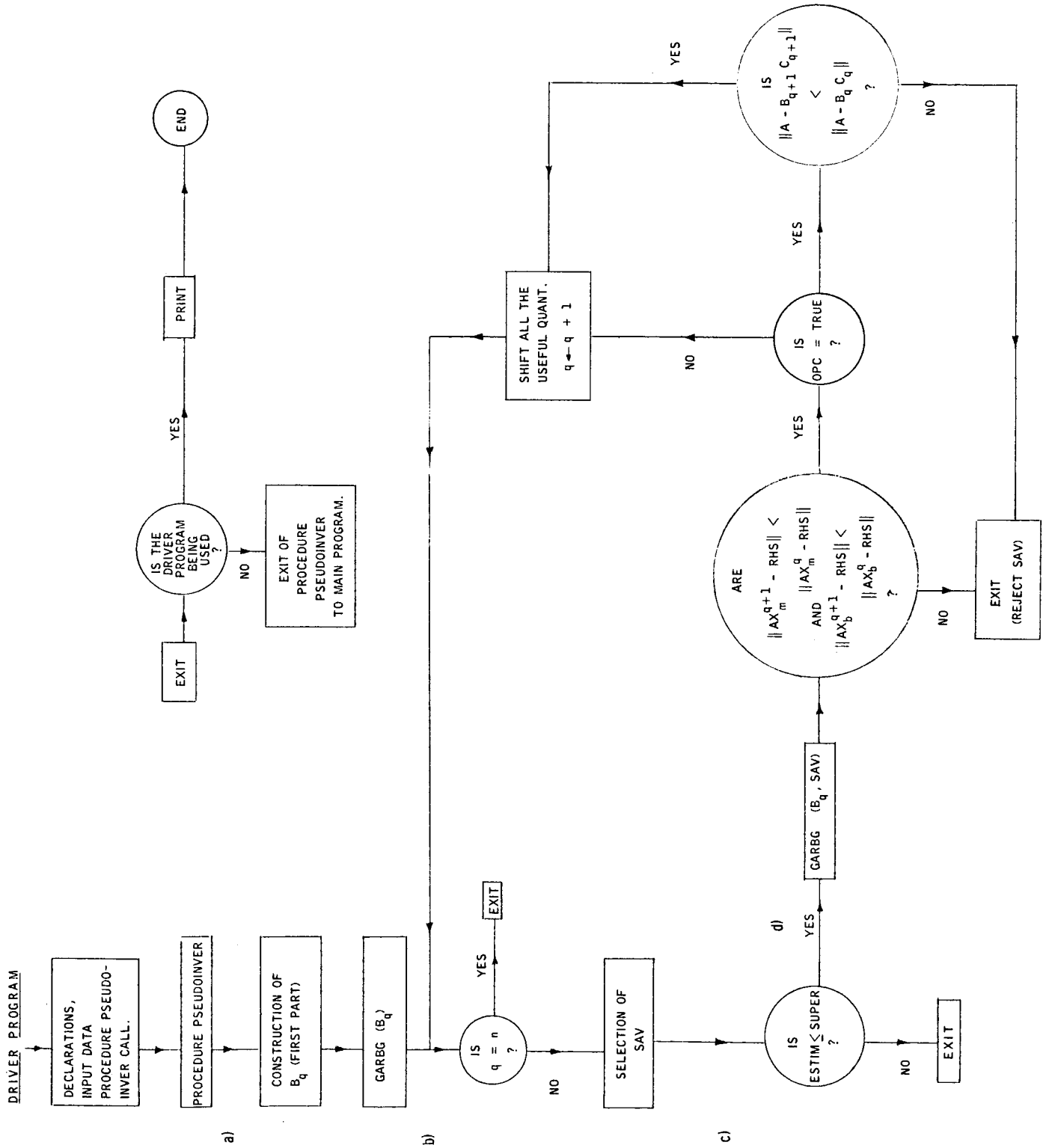

III. Program Use.

As described in the previous section, several parameters are needed besides the matrix A . Now we will explain the use and possibilities of these parameters.

Input.

M (integer) number of rows in A .

N (integer) number of columns in A .

T (integer) number of right-hand sides.

OPC (Boolean) If OPC is equal to 1 then the program will compute the matrices A^+ and $A^\#$, and the right-hand side $RHS = I(m \times m)$ will be automatically provided.

Moreover, OPC decides if in the test described in Section 2,d) the quality of the representation $(A = BC)$ is controlled. That test is done only if $OPC = TRUE$. If OPC is equal to FALSE then RHS an $M \times T$ matrix has to be provided and the program will compute $X_B = A^\# \cdot RHS$, and $X_M = A^+ \cdot RHS$, matrices that will be printed out instead of A^+ and $A^\#$.

SUPER (real) It is the SUPER of Section 2,c). If an upper bound for the elements of A^+ is known then SUPER can be set to this bound to take advantage of the smoothing property of this method; otherwise it is suggested that 10^{14} be used. It should be noted that, in general, a larger value than 10^{14}

will increase computing time by throwing unnecessary decisions into the test of Section 2,d). On the other hand, much smaller values may completely eliminate from further consideration some columns which could be used to decrease the error.

ORTP (real) This parameter was described in Section 2, a). Small values for ORTP (around 10^{-4}) in general will accelerate the process because the first part (construction of a basis of strongly independent column) is the fastest and as many columns as possible should be accepted there. Nevertheless, there are at least two cases in which a more careful choice of ORTP may be important. If higher precision in the answers is desired (at the cost of increased computing time), then a larger value of ORTP should be used, say 0.05. This will allow the second part of the program to choose "better" columns.

The other delicate case occurs when the matrix is very ill-conditioned and the rank is therefore not well defined. Here the use of a relatively large ORTP is important. Again values around 0.05 are recommended.

Summarizing, in a reasonable, well behaved problem a recommended set of parameters is:

$$\text{SUPER} = 10^{14}, \quad \text{ORTP} = 10^{-4}.$$

If the representation becomes very bad ($\|A - BC\|$ too large), the problem is not well behaved and more burden should be passed on to the second and safer test by increasing SUPER and decreasing ORTP .

If the user has information that certain variables are more significant than others, this information can be used by ordering the matrix A so that the columns of A corresponding to these variables appear first. This will insure that these columns are considered first for inclusion in the basis B .

If the complete program is used, then only the numerical data have to be punched. This is done in the following way.

As all the read statements are in the FREE FIELD form, available in the EXTENDED ALGOL for the B5000 at Stanford, no special format is necessary. Numbers can be punched in any format, needing just one space in between to separate them.

1st. card:	M	N	T	O P C	SUPER	O R T P
for instance	10	10	10	1	@14	0.001

Next cards will contain the matrix A punched by rows. As each READ asks for a whole row, care must be taken not to mix different rows in the same card.

Finally, if $O P C = 0$ the right-hand sides (RHS) have to be provided and are read by columns. Each new column must be started on a new card, so that there will be at least T cards required for the RHS .

If the PROCEDURE is used separately, then all these quantities are input parameters (with the same names as above).

If $OPC = 0$, then instead of these two last matrices, the minimum and basic solutions are printed out. As an example, we give the output for the problem:

$$\begin{pmatrix} 9 & 21 \\ 21 & 49 \end{pmatrix} X = \begin{pmatrix} 1 & 0 \\ 0 & 1 \end{pmatrix}$$

PSEUDOINVERSION OF THE MATRIX A . A IS 2 x 2 .

9.00000 @ + 00	2.10000 @ + 01
2.10000 @ + 01	4.90000 @ + 01

[PAGE]

NORM OF (BC - A) 2.37582 @ - 12

RESIDUAL FOR XM

9.19145 @ - 01	3.93919 @ - 01
----------------	----------------

RESIDUAL FOR XB

9.19145 @ - 01	3.93919 @ - 01
----------------	----------------

[PAGE]

MATRIX APSEUDOINVERSE

2.67532 @ - 03	6.24314 @ - 03
6.24381 @ - 03	1.45794 @ - 02

[PAGE]

MATRIX ADAGGER

ROW NUMBER 1

1.72461 @ - 02	4.02332 @ - 02
----------------	----------------

END OF THE RUN

The PROCEDURE PSEUDOINVER.

The call for this PROCEDURE is,

```
PSEUDOINVER (M, N, TI, OPC, SUPER, ORTP, A, RHS, EST, NXM, NXB,  
            APSEUDO, ADAGER, COF, XM, XB);
```

The first 8 parameters are input parameters and they have been described before. The only detail needed is: A(double real array [0:M, 0:N]), RHS [0:M, 0:TI];

OUTPUT PARAMETERS:

EST (real) Contains $\|BC - A\|$.

NXM, NXB (single real arrays [0:TI]) . They contain the residuals $\|AX_m - RHS\|$ and $\|AX_b - RHS\|$ respectively.

APSEUDO, ADAGER (Double real array [0:N, 0:M])

They contain the pseudoinverse of A and the matrix $A^\#$.

COF (Single integer array [0:N]) .

If $COF[I] = 0$ then both, the I^{th} row of $A^\#$ and X_b are different from zero, otherwise they are zero and that means the program has decided that the corresponding columns in A were linearly dependent with respect to the current basis.

XM, XB (double real arrays, [0:N, 0:TI])

They contain the minimum and basic solutions.

IV. Test Problems.

- a) Square segments of the Hilbert matrix have been tried, sizes varying between 3 and 10.

For $5 \leq n \leq 10$ the rank found in each case was 4. The norm of the pseudoinverses remained below 10^3 while for the true pseudoinverse (the inverse in these cases) the norms ranged between 10^5 for $n=5$ and 10^{13} for $n=10$. The norm, $\|A - BC\|$ was around 10^{-5} for all cases.

As is well known, the ill-conditioning of the Hilbert matrix segments increase with their dimension. However, because of the smoothing property of the method a bounded and reasonably accurate representation for the pseudoinverse was always obtained.

- b) Eighteen random matrices with random dimensions varying between 1 and 25 were generated and pseudoinverted. The norm $\|A - BC\|$ was always below 10^{-9} and the ranks were always found to be equal to $\min(m,n)$.
- c) Given three random integers m , n and r in the interval $[1, 25]$ a routine generated two random matrices, L ($m \times r$) and R ($r \times n$). Multiplying them we obtained a matrix A ($m \times n$) with rank at most equal to r ⁽¹⁾. With 20 matrices generated in this way, the results were similar to b). In every case the rank r was correctly determined. For most of these cases the rank r was less than $\min(m,n)$, and of course was unknown for the program.

(1) This test was suggested by Professor Gene H. Golub.

d) For each pair of values (m,n) several random matrices were generated and pseudoinverted. Average values of $\|A-BC\|$ for these matrices with $m=10,20,30$ and $n=10,20,30$ are shown in Table I. For the same problems, average computation time on the Burroughs B5000 at Stanford Computation Center are shown in Table II.

In all these matrices the rank was the maximum possible, i.e., $\text{rank} = \min(m,n)$ and it was properly determined by the program.

TABLE I

$\begin{matrix} n \\ m \end{matrix}$	10	20	30
10	5×10^{-9}	9×10^{-9}	4.5×10^{-8}
20	3×10^{-10}	4×10^{-8}	2.9×10^{-7}
30	5.8×10^{-10}	6.9×10^{-9}	2.6×10^{-7}

TABLE II

$\begin{matrix} n \\ m \end{matrix}$	10	20	30
10	7.6	13.9	20.7
20	16.5	49	91
30	27.3	92.5	180.6

$\|A - BC\|$

Comp. time in seconds

For a 40×40 matrix the answers were:

$$t = 413 \text{ sec.} \quad \|A - BC\| = 2.7 \times 10^{-7}$$

$$\text{rank} = 40 .$$

e) A common problem in many branches of applied sciences is the least squares fit, and is therefore one of the most important applications for this program. A related feature of the program is that, by ordering the variables, the user will be able to test their independence and eventually to decide if his model is appropriate to the phenomena being investigated. This is done by ordering

the matrix A so that the first coefficients correspond to the more important variables. The program will attempt to use these columns first to form the basis B . The necessity for such an ordering is clear from the fact that if we have n columns in A and the subspace spanned by these columns has dimension $(n-p)$ then we can construct with these columns as many as $\binom{n}{n-p}$ linearly independent sets.

In Figures II and III are shown the results obtained by running the program with least squares type problems. Again the elements of the matrices were generated randomly. Fig. II shows computation times on the B5000 for different values of m and $n=5, 10$. Fig. III shows the norm $\|A - BC\|$ for the same problems.

- f) Matrices with exact known inverses were tried obtaining good results and accuracy. Of course this program should not be used to invert a matrix which is known to be nonsingular and well-conditioned, because it will be around four times slower than an efficient matrix inverter. The program has also been used to obtain the pseudoinverse of singular and almost singular matrices stemming from the discretization of integral equations of the first kind, and problems in pattern recognition.

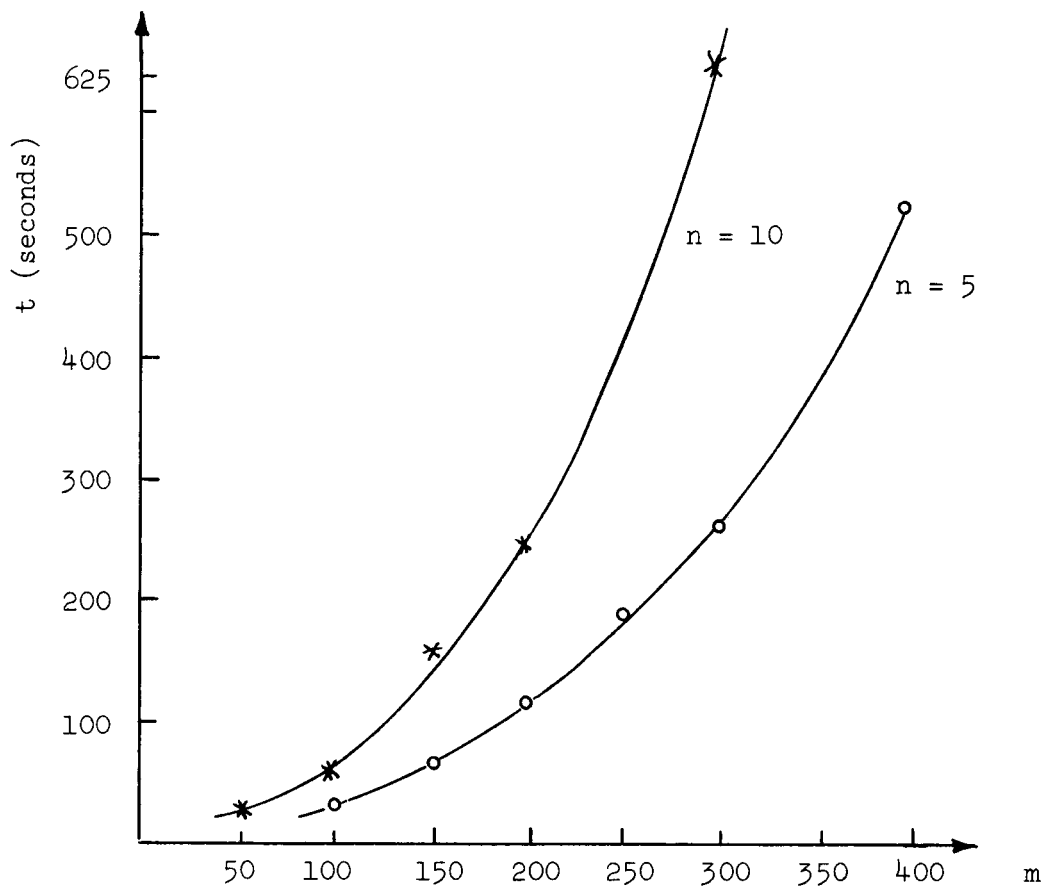

FIGURE II

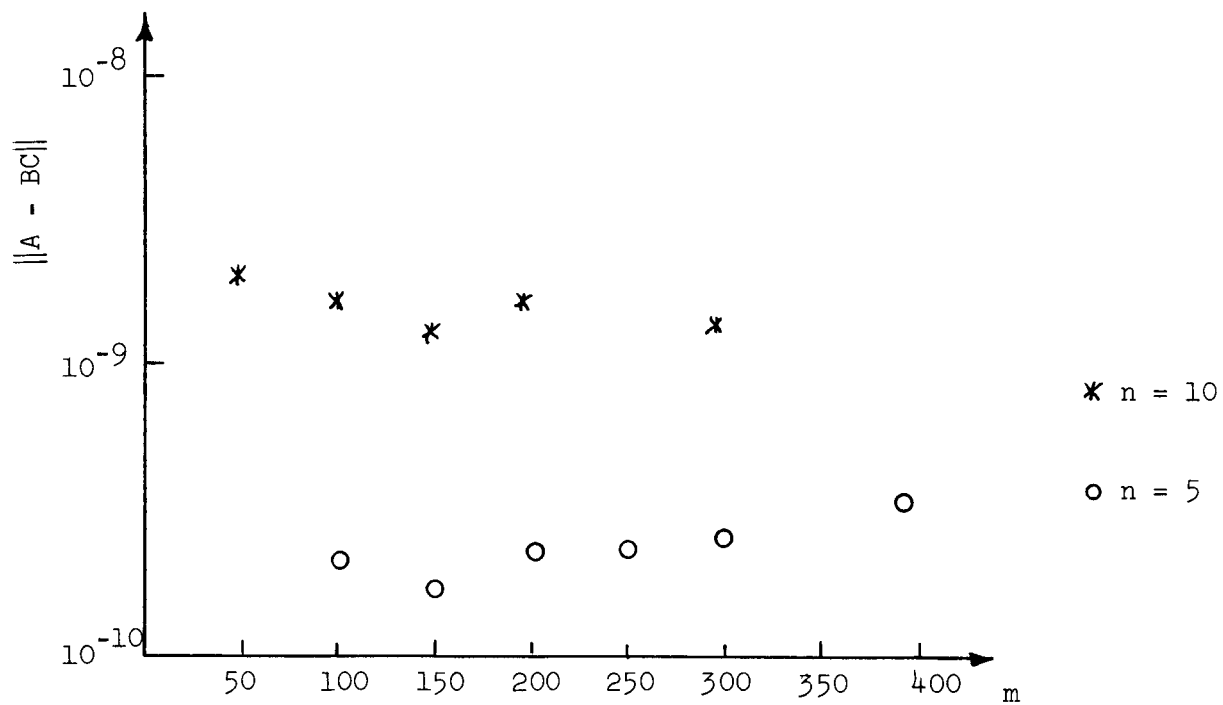

FIGURE III

V. Storage Requirements.

As all the array declarations are dynamical, the amount of storage depends on several parameters. If M, N, T are as before, and R is the final rank (number of accepted columns) then an estimate for the storage used in the PROCEDURE PSEUDOINVER is,

$$\text{Storage} \cong N^2 + 5MN + MR + 2NR + 2NT + \max(R^2, MN, MT)$$

the last term is present because in the PROCEDURE GARBG we have several independent blocks, and the storage corresponding to certain arrays is not simultaneously used.

If, as usual, R is not known, then it can be replaced by $\min(n,m)$. If the complete program is used then additional storage is needed,

$$\text{Addit. storage} \cong 3MN + MT + 2NT$$

Computer time rapidly increases when abusive use of the drum is made. From the experience obtained with the test problems, it is suggested that the total storage be less than 40,000 words.

REFERENCES

- [1] J. W. Blattner, Bordered Matrices, J. SIAM, 10, 528-536 (1962).
- [2] J. C. G. Boot , The Computation of the Generalized Inverse of Singular or Rectangular Matrices, Amer. Math. Monthly, 70, 302-303 (1963).
- [3] G. Golub and W. Kahan, Calculating the Singular Values and Pseudo-inverse of a Matrix, Stanford Univ. Technical Report CS8, (1964).
- [4] A. Ben-Israel and S. J. Wersan, An Elimination Method for Computing the Generalized Inverse of an Arbitrary Complex Matrix, J. ACM, 10, 532-537 (1963).
- [5] J. B. Rosen, Minimum and Basic Solutions to Singular Linear Systems. J. SIAM, 12, 156-162 (1964).
- [6] J. Todd, The Condition of the Finite Segments of the Hilbert Matrix, NBS App. Math. Series, 39, 109-116 (1954).

APPENDIX

AN EXTENDED ALGOL PROGRAM TO COMPUTE THE
PSEUDOINVERSE OF AN $M \times N$ REAL MATRIX
AND OTHER RELATED QUANTITIES.

```

BEGIN COMMENT PSEUDOINVERSE OF A MxN MATRIX OF UNKNOWN RANK;
INTEGER M,N,TI,I,J ; REAL SUPER,EST,TPD,ORTP ;
BOOLEAN OPC ; LABEL OVER,FIU;
COMMENT DRIVER PROGRAM. FIRST PARAMETERS ARE READ IN,
AND USED FOR FURTHER DYNAMICAL ARRAY DECLARATIONS;
OVER: READ (M,N,TI,OPC,SUPER,ORTP) [FIU];
BEGIN INTEGER ARRAY COF[0:N];
ARRAY A[0:M,0:N],RHS[0:M,0:TI],XM,XB[0:N,0:TI],NXM,NXB[0:TI],
APSEUDO,ADAGER[0:N,0:M] ; LABEL NOPR,NOPR1;
FORMAT PRMAT(( 8E14.5)///),
TIT1("PSEUDOINVERSION OF THE MATRIX A"///"A IS",I3,"X",I3/),
TIT7("NORM OF (BC-A)"//X3,E15.5/"RESIDUAL FOR XM"/(8E15.5/)),
TIT8("MATRIX A PSEUDOINVERSE"/),TIT9("MATRIX A DAGGER"/),
TIT10(X6,"XM"/),TIT20(//X6,"XB"/),TITL38(/"ROW NUMBER",I3/),
TIT77(/"RESIDUAL FOR XB "/(8E15.5/)),SQL(8E15.6/),
ENDE(/"END OF THE RUN"//X15,"* * * * * * * * * * " ///);
PROCEDURE PRT(A,M,N) ;
INTEGER M,N; ARRAY A[0,0];
COMMENT PRT PRINT OUT THE MxN MATRIX A;
BEGIN FORMAT TITL46(/ 8E14.5); INTEGER SE,K,R;
SE ← N DIV 8 ; K ← N MOD 8 ;
FOR R←0 STEP 1 UNTIL SE-1 DO
BEGIN FOR I←1 STEP 1 UNTIL M DO
WRITE (TITL46,FOR J←1 STEP 1 UNTIL 8 DO A[I,8 ×R+J]);
WRITE ([PAGE])
END ; IF K≠0 THEN FOR I←1 STEP 1 UNTIL M DO
WRITE(TITL46,FOR J←1 STEP 1 UNTIL K DO A[I,8 ×SE+J]);
WRITE ([PAGE])
END PRT ;
PROCEDURE PSEUDOINVER (M,N,TI,SUPER,OPC,A,RHS,ORTP,EST,NXM,
NXB,APSEUDO,ADAGER,COF,XM,XB);
INTEGER M,N,TI ; INTEGER ARRAY COF[0]; BOOLEAN OPC;
REAL SUPER,EST,ORTP ;
ARRAY A,RHS,APSEUDO,ADAGER,XM,XB[0,0],NXM,NXB[0];
COMMENT PSEUDOINVER COMPUTES THE PSEUDOINVERSE OF A MxN MATRIX A,
AND OTHER RELATED QUANTITIES. THE ESPECIAL WAY OF ROUNDING-OFF
AFTER DOUBLE PRECISION OPERATIONS IS DUE TO
MR. PETER BUSINGER AND PROF. GENE GOLUB;
BEGIN INTEGER J,CONT,Q,K,T,BUENO,R,I,PE,MA; BOOLEAN SWITCH;
ARRAY BQ,AN[0:M,0:N],INVQ[0:N,0:N],NRHS,UPI,DOPI[0:TI],
G,UQ,SAV[0:N],X1,X2[0:N,0:TI],BPS,API,ADI[0:N,0:M];
REAL CLUF,ALFAQ,BEQ,AL,SUPALF,B,NXB1,NXM1,AAA,BBB,CCC,
UPI1,DOPI1,ESTI,ASO,SUM,ES,PERTUB,ESTIM,TPD,MINIR;
MA ← IF M<N THEN N ELSE M ;
BEGIN ARRAY TRUC,TU,VQ,TEMP[0:MA]; LABEL SECND,RFIN,
NONES,LOP,TRES,CUATRO,MAIS,CAS,FINI,OTRA,FORCED;
COMMENT TRMAVC,MATRIMUL,MULTIVEC,ESC,TRANSP AND VEC SUM ARE
PROCEDURES PERFORMING MATRIX AND VECTOR OPERATIONS,
SOME OF THEM IN DOUBLE PRECISION;
PROCEDURE TRMAVC (A,V,I,J,M,N);
ARRAY A[0,0],V[0]; INTEGER I,J,M,N ;
BEGIN INTEGER K;
IF I=0 THEN FOR K←1 STEP 1 UNTIL M DO V[K]← A[K,J]
ELSE FOR K←1 STEP 1 UNTIL N DO V[K]← A[I,K]
END TRMAVC ;

```



```

PROCEDURE MATRIMUL (A,B,C,P,Q,R) ;
  ARRAY A,B,C[0,0] ; INTEGER P,Q,R ;
  BEGIN
    INTEGER I,J,K ; REAL AC,BC ;
    FOR I+1 STEP 1 UNTIL P DO FOR J+1 STEP 1 UNTIL R DO
      BEGIN
        AC+BC+0 ; FOR K+1 STEP 1 UNTIL Q DO
          DOUBLE(A[I,K],0,B[K,J],0,x,AC,BC,+,+,AC,BC) ;
          C[I,J] + AC+BC&AC[1:1:8]/5.49755813891@11
        END
      END
    END MATRIMUL ;
PROCEDURE MULTIVEC (A,V1,V2,P,Q) ;
  ARRAY A[0,0],V1,V2[0] ; INTEGER P,Q ;
  BEGIN
    INTEGER I,J ; REAL AC,BC ;
    FOR I+1 STEP 1 UNTIL P DO
      BEGIN
        AC+BC+0 ; FOR J+1 STEP 1 UNTIL Q DO
          DOUBLE (A[I,J],0,V1[J],0,x,AC,BC,+,+,AC,BC) ;
          V2[I]+ AC+BC&AC[1:1:8]/5.49755813891@11
        END
      END
    END MULTIVEC ;
PROCEDURE ESC(A,B,C,P) ;
  ARRAY A,B[0] ; REAL C ; INTEGER P ;
  BEGIN
    INTEGER I ;
    C+0 ; FOR I+1 STEP 1 UNTIL P DO C+ A[I]* B[I]+C
  END ESC ;
PROCEDURE TRANSP (A,B,P,Q) ;
  ARRAY A,B [0,0] ; INTEGER P,Q ;
  BEGIN
    INTEGER I,J ;
    FOR I+1 STEP 1 UNTIL P DO
      FOR J+1 STEP 1 UNTIL Q DO B[J,I] + A[I,J]
    END TRANSP ;
PROCEDURE VEC SUM (A,B,C,ALF,BET,N) ;
  ARRAY A,B,C[0] ; REAL ALF,BET ; INTEGER N ;
  BEGIN
    INTEGER I ;
    FOR I+1 STEP 1 UNTIL N DO C[I]+A[I]*ALF+B[I]* BET
  END VEC SUM ;
PROCEDURE PSEUDO (NQ,ALFQ,UQ,Q) ;
  ARRAY NQ[0,0],UQ[0] ; REAL ALFQ ; INTEGER Q ;
COMMENT GIVEN (BQ"BQ) INVERSE, PSEUDO CONSTRUCT (B(Q+1)"B(Q+1))
INVERSE)
  BEGIN
    REAL A ; INTEGER I,J ;
    ALFQ + 1/ALFQ ;
    FOR I+1 STEP 1 UNTIL Q DO FOR J+1 STEP 1 UNTIL Q DO
      DOUBLE(ALFQ,0,UQ[I],0,x,UQ[J],0,x,NQ[I,J],0,+,+,
        NQ[I,J],A) ; Q+Q+1 ; UQ[Q]+ -1 ;
    FOR J+1 STEP 1 UNTIL Q DO
      NQ[J,Q]+ NQ[Q,J] + -ALFQ * UQ[J]
    END PSEUDO ;
PROCEDURE GARBG(M,N,T,TI,COF,BQ,G,RHS,BPS,A,NRHS,AAA,
  NXM,NXB,NXM1,NXB1,APSEUDO,ADAGER,XM,XB,EST) ;
  REAL NXM1,NXB1,EST,AAA ; INTEGER N,M,T,TI ;
  INTEGER ARRAY COF[0] ;
  ARRAY XM,XB,APSEUDO,ADAGER,BQ,RHS,BPS,A[0,0],
  NXB,NXM,G,NRHS[0] ;
COMMENT GIVEN THE BASIS BQ: A PSEUDOINVERSE, A DAGGER, XM, XB,
NXM, NXB, AND NORM OF (A-BQC) ARE COMPUTED ;
  BEGIN
    INTEGER I,Q,J,R,MA ; REAL B,PER,ALFAQ ;

```

```

        ARRAY C[0:T,0:N], BQ1[0:M,0:T], UQ[0:N] ;
        IF M<N THEN MA←N ELSE MA←M ;
        BEGIN ARRAY AN[0:T,0:N] ;
        BEGIN ARRAY INVQ1[0:T,0:T], TU, TEMP[0:MA] ;
COMMENT A DAGGER IS CALCULATED;
        FOR I←1 STEP 1 UNTIL M DO
        BEGIN Q←COF[I] ;
        IF Q≠0 THEN FOR J←1 STEP 1 UNTIL M DO
        BEGIN BQ1[J,Q]←BQ[J,Q]/G[I] ;
        ADAGER[I,J]←BPS[Q,J]←BPS[Q,J]×G[I] ;
        END
        END ;
COMMENT C AND C-PSEUDOINVERSE ARE CALCULATED;
        MATRIMUL(BPS,A,C,T,M,N);
        TRMAVC(C,TU,1,1,T,N); ESC(TU,TU,B,N);
        INVQ1[1,1]←1/B;
        FOR Q←2 STEP 1 UNTIL T DO
        BEGIN R←Q-1; TRMAVC(C,TU,Q,Q,T,N);
        MULTIVEC(C,TU,TEMP,R,N);
        MULTIVEC(INVQ1,TEMP,UQ,R,R);
        FOR I←1 STEP 1 UNTIL N DO
        BEGIN PER←0;
        FOR J←1 STEP 1 UNTIL R DO
        PER←PER+C[J,I] × UQ[J]; TEMP[I] ← PER
        END ;
        VEC SUM(TU,TEMP,TEMP,1,-1,N);
        ESC(TEMP,TEMP,ALFAQ,N);
        PSEUDO(INVQ1,ALFAQ,UQ,R)
        END ; MATRIMUL(INVQ1,C,AN,T,T,N) ;
        END ;
COMMENT NORM OF (A-BC) IS COMPUTED;
        BEGIN ARRAY BQC[0:MA,0:N] ;
        TRANSP(AN,BQC,T,N) ;
        MATRIMUL(BQC,BPS,APSEUDO,N,T,M);
        MATRIMUL(BQ1,C,BQC,M,T,N); EST←0;
        FOR I←1 STEP 1 UNTIL M DO
        BEGIN PER←0;
        FOR J←1 STEP 1 UNTIL N DO
        PER←PER+ABS(BQC[I,J]-A[I,J]);
        IF PER≥EST THEN EST←PER
        END
        END
        END ;
        EST←EST/AAA;
COMMENT THE MINIMUM AND BASIC SOLUTIONS ARE COMPUTED;
        MATRIMUL(APSEUDO,RHS,XM,N,M,TI);
        MATRIMUL(ADAGER,RHS,XB,N,M,TI);
        BEGIN ARRAY AN[0:M,0:TI];
COMMENT THE RESIDUALS FOR THESE SOLUTIONS ARE COMPUTED;
        MATRIMUL(A,XM,AN,M,N,TI);
        FOR J←1 STEP 1 UNTIL TI DO
        BEGIN NXM1←0;
        FOR I←1 STEP 1 UNTIL M DO
        NXM1←(AN[I,J]-RHS[I,J])*2+NXM1;
        NXM1←SQRT(NXM1); NXM[J]←NXM1/NRHS[J]

```

```

        END;
        MATRIMJL(A,XB,AN,M,N,TI);
        FOR J+1 STEP 1 UNTIL TI DO
        BEGIN NXB1+0;
            FOR I+1 STEP 1 UNTIL M DO
                NXB1+(AN[I,J]-RHS[I,J])*2 + NXB1 ;
                NXB1+ SQRT(NXB1); NXB[J]+ NXB1/NRHS[J]
            END ; NXB1 + NXM1 + 0;
            FOR I+1 STEP 1 UNTIL TI DO
                BEGIN NXB1 + NXB1+ NXB[I]*2 ;
                    NXM1 + NXM1+NXM[I] *2
                END ; NXM1+ SQRT(NXM1); NXB1+ SQRT(NXB1);
            END;
        END GARBG ;
COMMENT  PROCEDURE PSEUDDINVER BODY ;
        MINIR +@-20; AAA+CCC+0 ;
COMMENT  NORM OF A AND NORM OF THE RHS;
        FOR J+1 STEP 1 UNTIL N DO FOR I+1 STEP 1 UNTIL M DO
        BEGIN BBB+ ABS(A[I,J]); IF BBB>AAA THEN AAA+BBB
        END ; FOR J+1 STEP 1 UNTIL TI DO
        BEGIN CCC+0; FOR I+1 STEP 1 UNTIL M DO
            CCC+ CCC+RHS[I,J]* 2 ; CCC+ SQRT(CCC);
            NRHS[J]+ IF CCC>1 THEN CCC ELSE 1 ;
        END; IF AAA<1 THEN AAA+1 ;
        FOR I+1 STEP 1 UNTIL N DO
        BEGIN COF[I]+ 0;
            FOR J+1 STEP 1 UNTIL M DO ADI[I,J]+ADAGER[I,J]+ 0;
        END ;
COMMENT  THE MATRIX A IS NORMALIZED AND STORED ON AN ,
        G CONTAINS THE NORMALIZING COEFFICIENTS ;
        FOR J+1 STEP 1 UNTIL N DO
        BEGIN TRMAVC(A,TU,0,J,M,N);
            ESC(TU,TU,CLUF,M);
            G[J]+IF CLUF > 1.0 THEN 1.0/SQRT(CLUF) ELSE 1.0;
        END ; FOR I+1 STEP 1 UNTIL M DO
        BEGIN FOR J+1 STEP 1 UNTIL N DO
            AN[I,J] + A[I,J]* G[J]
        END ;
COMMENT  THE CONSTRUCTION OF A BASIS OF STRONGLY
        INDEPENDENT VECTORS IS STARTED;
        CONT+1; SUPALF+ 0 ; Q+ K+ T+ 1;
        COF[1]+1; INVQ[1,1]+ 1; SWITCH+ FALSE ;
COMMENT  SEARCH FOR INDEPENDENT COLUMNS OF A. WHEN THE COLUMNS
        ARE EXHAUSTED AN EXIT IS PROVIDED TO LABEL FINI. IN CONT
        A RECORD IS KEPT ON THE WAY IN WHICH COLUMS ARE ACCEPTED;
        LOP : IF Q=N THEN GO TO FINI ;
            T+K ; Q+Q+1; K+K+1;
COMMENT  PROJECTION OF A COLUMN OF AN ON THE ORTHOGOVAL
        SUBSPACE OF BQ;
        CAS : TRMAVC(AN,VQ,0,Q,M,N);
            FOR I+1 STEP 1 UNTIL T DO
            BEGIN ALFAQ+ 0;
                FOR J+1 STEP 1 UNTIL M DO
                    ALFAQ+ ALFAQ+BQ[J,I]*VQ[J]; TEMP[I]+ ALFAQ

```

```

END ;
MULTIVEC(INVQ,TEMP,UQ,T,T);
MULTIVEC(BQ,UQ,TEMP,M,T);
VECSUM(VQ,TEMP,TEMP,1,-1,M);
ESC(TEMP,TEMP,ALFAQ,M);
COMMENT FIRST TEST FOR ACCEPTANCE AS AN INDEPENDENT COLUMN;
IF ALFAQ ≤ ORTP THEN GO TO NONES;
IF CONT=2 THEN CONT+ 3 ;
COMMENT CONSTRUCTION OF B(Q+1);
PSEUDO (INVQ,ALFAQ,UQ,T);
FOR I+1 STEP 1 UNTIL M DO BQ[I,K]+ VQ[I];
COF [Q]← K ; GO TO LOP ;
NONES : COF[Q] ← 0; K← K-1 ;
IF CONT ≠ 3 THEN
BEGIN CONT+2 ; GO TO TRES ;
END ; GO TO LOP ;
COMMENT IF CONT≠2 THEN THE REJECTED COLUMNS ARE REVISED IN ORDER
TO TAKE THE MOST INDEPENDENT WITH RESPECT TO THE BASIS BQ.
CONT=1 MEANS THAT ALL THE COLUMNS HAVE BEEN TAKEN IN THE
FIRST SWEEP. CONT=3 MEANS THAT A COLUMN HAS BEEN REJECTED
AND LATER ON,ANOTHER HAS BEEN ACCEPTED;
OTRA : Q+ 2 ; SUPALF← 0; BUENO← 0;
MAIS : IF Q=N+1 THEN GO TO CUATRO ;
IF COF[Q]≠ 0 THEN
BEGIN Q← Q+1 ; GO TO MAIS ;
END ; GO TO CAS ;
TRES : IF ALFAQ ≥ SUPALF THEN
BEGIN SUPALF ← ALFAQ ;
FOR I+1 STEP 1 UNTIL M DO TRUC[I]+ VQ[I];
FOR I+1 STEP 1 UNTIL T DO
SAV[I]+ UQ[I] ; BUENO ← Q
END ; IF CONT=2 THEN GO TO LOP ;
IF Q=N THEN GO TO CUATRO ;
Q← Q+1; GO TO MAIS;
COMMENT IF THE PROJECTION OF THE SELECTED COLUMN IS LESS THAN ε=20
THEN SAV IS REJECTED AND WE FINISH;
CUATRO : IF SUPALF ≤ MINIR THEN GO TO RFIN ;
AL ←SUM ← 0;
COMMENT THE NORM OF (B(Q+1)·B(Q+1)) INVERSE IS ESTIMATED,AND ITS
VALUE IS CONTROLLED;
FOR I+1 STEP 1 UNTIL T DO
BEGIN FOR J+1 STEP 1 UNTIL T DO
SUM ←SUM + ABS(INVQ[I,J]);
IF SUM>AL THEN AL←SUM
END ;
ESTIM ← AL+(SQRT(T)+1.0)/SUPALF ;
IF ESTIM ≥ SUPER THEN GO TO RFIN ;
COMMENT SAV HAS PASSED THE TESTS OF SECTION 2,c), NOW IS USED
TENTATIVELY IN B(Q+1) TO SEE IF THE RESIDUALS DIMINISH;
FORCED : PSEJDO(INVQ,SUPALF,SAV,T);
COF[BUENO]← T ;
FOR I+1 STEP 1 UNTIL M DO BQ[I,T]+ TRUC[I];
COMMENT WE CONSTRUCT NOW B=PSEUDO,C,A=PSEUDO AND ADAGGER;
FINI : FOR I+1 STEP 1 UNTIL T DO FOR J+1 STEP 1 UNTIL M DO

```

```

      BEGIN ES←0; FOR PE←1 STEP 1 UNTIL T DO
        ES ← ES + INVQ[I,PE] × BQ[J,PE] ; BPS[I,J] ←ES
COMMENT AS WE WANT TO COMPARE RESULTS FOR TWO DIFFERENT BASES,
        SWITCH PROVIDES A WAY TO DECIDE THE CALL OF GARBG;
      END ; IF SWITCH THEN GO TO SECND ;
      GARBG (M,N,T,TI,COF,BQ,G,RHS,BPS,A,NRHS,AAA,
        NXM,NXB,NXM1,NXB1,APSEUDO,ADAGER,XM,XB,EST) ;
      IF T=N THEN GO TO RFIN ; SWITCH ← TRUE ;
      IF CONT = 2 THEN
        BEGIN CONT ← 1; GO TO CUATRO ;
        END ; GO TO OTRA ;
SECND : GARBG (M,N,T,TI,COF,BQ,G,RHS,BPS,A,NRHS,AAA,
        UPI,DOPI,UPI1,DOPI1,API,ADI,X1,X2,ESTI);
COMMENT NOW THE TEST OF SECTION 2,D) IS MADE;
      IF NXB1≥ DOPI1 AND NXM1≥UPI1 THEN
COMMENT IF NOT OPC OR EST≥ ESTI THEN
        BEGIN IF NOT OPC OR EST≥ ESTI THEN
          ARE SHIFTED;
          BEGIN NXM1←UPI1; NXB1← DOPI1; EST←ESTI ;
            FOR I←1 STEP 1 UNTIL N DO
              BEGIN FOR J←1 STEP 1 UNTIL M DO
                BEGIN APSEUDO[I,J]← API[I,J] ;
                  ADAGER[I,J]←ADI[I,J]
                END; FOR J←1 STEP 1 UNTIL TI DO
                  BEGIN XM[I,J]←X1[I,J]; XB[I,J]← X2[I,J];
                    NXM[J]←UPI[J]; NXB[J]←DOPI[J];
                  END;
                END ; IF T=N THEN
                  BEGIN BUEND←0 ; GO TO RFIN
                  END ; GO TO OTRA
            END
          END ;
RFIN : COF[BUEND]← 0;
      END
      END PSEUDOINVER ;
COMMENT BODY OF THE DRIVER PROGRAM, THE INPUT-OUTPUT AND THE CALL
      OF PSEUDOINVER ARE INCLUDED;
      FOR I←1 STEP 1 UNTIL M DO
        READ(FOR J←1 STEP 1 UNTIL N DO A[I,J]);
        WRITE([PAGE]); WRITE(TIT1,M,N); PRT(A,M,N);
        IF NOT OPC THEN FOR I←1 STEP 1 UNTIL TI DO
          READ( FOR J←1 STEP 1 UNTIL M DO RHS[J,I])
        ELSE FOR I←1 STEP 1 UNTIL M DO FOR J←1 STEP 1 UNTIL M DO
          RHS[I,J]← IF I=J THEN 1 ELSE 0 ;
        PSEUDOINVER(M,N,TI,SUPER,OPC,A,RHS,ORTP,EST,NXM,
          NXB,APSEUDO,ADAGER,COF,XM,XB);
        WRITE(TIT7,EST,FOR I←1 STEP 1 UNTIL TI DO NXM[I]);
        WRITE(TIT77, FOR I←1 STEP 1 UNTIL TI DO NXB[I]);
        IF OPC THEN
          BEGIN WRITE([PAGE]) ; WRITE(TIT8);
            PRT(APSEUDO,N,M); WRITE (TIT9);
            FOR I←1 STEP 1 UNTIL N DO
              BEGIN IF COF[I]=0 THEN GO TO NOPR ;
                WRITE (TITL38,I);
                WRITE (PRMAT,FOR J←1 STEP 1 UNTIL M DO ADAGER[I,J]) ;
              END
            END
          END

```

```

NOPR: END
      END
      ELSE
        BEGIN WRITE([PAGE]); WRITE(TIT10) ;
              FOR I+1 STEP 1 UNTIL N DO
                WRITE(SOL, FOR J+1 STEP 1 UNTIL TI DO XM[I,J]);
                WRITE (TIT20) ; FOR I+1 STEP 1 UNTIL N DO
                  BEGIN IF COF [I]=0 THEN GO TO NOPR1;
                    WRITE(TITL38,I);
                    WRITE(SOL, FOR J+1 STEP 1 UNTIL TI DO XB[I,J]);
                  END;
                JUST BY ADDING NEW SETS OF DATAS MORE PROBLEMS CAN BE RUN;
              END ; WRITE(ENDE); GO TO OVER ;
NOPR1 :
COMMENT
      END ;
      FIU :
END .

```