

NASA CONTRACTOR  
REPORT



NASA CR-258

NASA CR-258

N65-27018  
 RECEIVED BY (NAME)  
 DATE  
 CATEGORY

# INVESTIGATION OF NONLINEAR INTERACTION PHENOMENA IN THE IONOSPHERE

*by H. C. Hsieh, R. J. Lomax, and J. E. Rowe*

Prepared under Grant No. NsG-696 by  
UNIVERSITY OF MICHIGAN  
Ann Arbor, Mich.

for

PRICE \$ \_\_\_\_\_  
 PRICE(S) \$ 5.00  
 Hard copy (HC) \_\_\_\_\_  
 Microfiche (MF) \_\_\_\_\_

INVESTIGATION OF NONLINEAR INTERACTION PHENOMENA  
IN THE IONOSPHERE

By H. C. Hsieh, R. J. Lomax, and J. E. Rowe

Distribution of this report is provided in the interest of information exchange. Responsibility for the contents resides in the author or organization that prepared it.

Prepared under Grant No. NsG-696 by  
UNIVERSITY OF MICHIGAN  
Ann Arbor, Mich.

for

NATIONAL AERONAUTICS AND SPACE ADMINISTRATION

## TABLE OF CONTENTS

	<u>Page</u>
LIST OF ILLUSTRATIONS	vi
1. GENERAL INTRODUCTION	1
2. STUDY OF THERMAL RADIATION (NOISE) FROM THE IONOSPHERE	1
2.1 Introduction	1
2.2 Statement of the Problem	3
2.2.1 Nature of the Problem	3
2.2.2 Basic Approach	4
2.3 Background and Related Materials	5
2.3.1 Nyquist Source Treatment	5
2.3.2 Generalized Nyquist Theorem	6
2.3.3 Langevin Equation	7
2.3.4 Thermal Noise	9
2.3.5 Coordinate Systems	9
3. PROPAGATION OF NATURALLY OCCURRING RADIO NOISE THROUGH THE IONOSPHERE	9
3.1 Introduction	9
3.2 Statement of the Problem and Basic Approach	12
3.3 Background and Related Material	13
3.3.1 Traveling-Wave Amplification Process	13
3.3.2 Transverse Resonance Plasma Instability	15
3.3.3 Landau Damping of Whistlers	16
3.3.4 Some General Discussion on Plasma Instabilities	19
4. GENERATION OF VLF EMISSIONS IN THE EXOSPHERE BY DOUBLE-BEAM INSTABILITY	19
4.1 Introduction	19
4.2 Statement of the Problem	21
4.2.1 Nature of the Problem	21
4.2.2 Formulation of the Problem	22
4.3 Background and Related Materials	23
4.3.1 Multi-Beam Interaction and Space-Charge-Wave Amplification Effect	23
4.3.2 Beam-Plasma Instability	26

	<u>Page</u>
4.3.3 Conversion of Longitudinal Space-Charge-Wave Energy into a Transverse Electromagnetic Radiation	28
4.3.3a Microwave Electron Tube Mechanism	28
4.3.3b Scattering Process	29
4.3.4 Miscellaneous	30
4.3.4a Plasma Instability and Ionospheric Phenomena	30
4.3.4b Mechanism of Injection of Solar Plasma into Magnetosphere	31
4.3.4c Magneto-Ionic Theory and VLF Emission	31
5. GENERATION OF NATURAL RADIO EMISSION BY PLASMA-OSCILLATION	32
5.1 Introduction	32
5.2 Statement of the Problem	33
5.3 Background and Related Materials	35
5.3.1 Solar Radio Bursts	35
5.3.1a Observational Data	35
5.3.1b Theoretical Work on a Generation Mechanism for Radio Bursts	37
5.3.2 Beam-Plasma Interaction	39
5.3.2a Space-Charge-Wave Amplification	39
5.3.2b Beam-Plasma Instability	40
5.3.2c Conversion Process by Scattering	41
5.3.2d Conversion Process by a Microwave Electron Tube Model	41
5.3.3 Radiation from Plasma	42
5.3.3a Radiation from Moving Sources	42
5.3.3b Radiation by Plasma Oscillation	44
APPENDIX A. BOLTZMANN EQUATION ANALYSIS	47
APPENDIX B. LAGRANGIAN ANALYSIS	57
1. Introduction	57
2. Nonlinear Equations for Combined One-Dimensional Beam-Plasma and Circuit	57
2.1 Definitions	59
2.2 R-f Circuit Equation	60
3. Double-Beam Interaction	66

	<u>Page</u>
4. Beam-Plasma Interaction	68
LIST OF REFERENCES	71

## LIST OF ILLUSTRATIONS

<u>Figure</u>	<u>Page</u>	
A.1	Interpenetrating Ion and Electron Stream. Plot of Electron Current at Various Planes.	55
A.2	Interpenetrating Ion and Electron Streams. Plot of Ion Current at Various Planes.	56
B.1	Beam-Plasma-Circuit Interaction Configuration.	58
B.2	Plasma Frequency Reduction Factors for a Double Charge Field Configuration.	67
B.3	Double-Beam Interaction. Effect of Space Charge on Fundamental Current Emplitude. ( $\epsilon_1 = \epsilon_2 = -1, \alpha = 0.2, I' = \eta' = 0, b = 0$ )	69
B.4	Beam-Plasma Interaction. Fundamental Current Amplitude Vs. $\omega_p/\omega, b$ and $\eta'$ . ( $\epsilon_1 = -1, \epsilon_2 = +1, \alpha = 0.2, I' = 0$ )	70

# INVESTIGATION OF NONLINEAR INTERACTION PHENOMENA IN THE IONOSPHERE

## 1. General Introduction

The overall objective of this research investigation is to study such ionospheric phenomena as thermal radiation noise, the propagation of naturally occurring radio noise through the ionosphere and the generation of VLF emissions. In particular, various traveling-wave interaction mechanisms are being studied in order to determine their applicability in explaining various ionospheric phenomena such as indicated above.

Many of the phenomena of interest involve the interaction of drifting streams of charged particles and electromagnetic waves, including the excitation of electrostatic plasma oscillations and cyclotron wave interactions. Since many of these phenomena are nonlinear it is reasonable to apply the nonlinear methods of analysis used on TWT's and beam-plasma interactions to their study. The two nonlinear methods being used are a Lagrangian particle analysis and one in which the nonlinear collisionless Boltzmann equation is solved by a moment expansion method.

The following sections of this report outline the particular problems presently being investigated and a summary of the analysis methods is given in the appendices.

## 2. Study of Thermal Radiation (Noise) from the Ionosphere

2.1 Introduction. It is well known that because the ionosphere acts as an absorber of radio waves, it can also act as an emitter of thermal radio noise. It has been conclusively demonstrated by various

workers<sup>1,2,3,4</sup> that the thermal emission from the D-region can, under favorable conditions, be observed with a dipole antenna. For example, Pawsey et al. have identified and measured the thermal radiation from the ionosphere in the vicinity of 2 mc/s in the temperate latitude.

It appears that usually the thermal radiation has been neglected because its level is exceedingly low, as illustrated by Pawsey et al. and it does not constitute an appreciable source of interference in radio communication. It must be pointed out, however, that the noise radiated from a plasma (e.g., the ionosphere) is not, in all cases, necessarily a detrimental effect, such as it is in communication, since, if the spectral distribution of the emitted energy is characteristic of the plasma properties, a measurement of radiation provides specific information on the plasma. As an example, knowledge of the radiated power gives a measure of the electron temperature in the plasma, and this has been used as a powerful diagnostic technique. For example, Pawsey et al. have obtained information on the electron temperature, from their observation, using a method based on a simple macroscopic concept under thermodynamic equilibrium. With the aid of the Nyquist noise formula for available noise power, they found the temperature of electrons at a height of about 70 and 80 km to be around 240 to 290°K.

For a plasma (e.g., ionosphere) in a steady state, a macroscopic radiative transfer concept without detailed knowledge of the atomic processes can be applied and emission spectrum determined from the electromagnetic wave absorption, transmission and reflection properties of the plasma. These determinations are, in general, complicated by the nonuniformity and geometrical configuration of the emitting plasma.

In view of the fact that a current survey of the literature shows that no detailed information with regard to the generation mechanism of



ionospheric thermal radiation is available, it is proposed to undertake the study of this phenomena, which should serve as an aid toward our understanding of the fundamental process in the ionospheric thermal noise mechanism.

## 2.2 Statement of the Problem.

2.2.1 Nature of the Problem. It is well known that the thermal radiation from dissipative bodies is due to the random thermal motion of the charges in the bodies. If the body is at a uniform temperature, one approach that may be used for studying the radiation may be called the integral approach. The body as a whole is considered to be nonradiating, and the power that it absorbs from its surrounding, which is assumed to be at the temperature of the body, can be computed. This power is set equal to the power radiated by the body. In this approach one makes no attempt to determine the noise current fluctuations that are the cause of the thermal radiation. In those cases, in which the temperature of the body is nonuniform, this approach fails.

Another approach, which may be called the "Nyquist source treatment", focuses attention upon the sources of the radiation, the relevant statistical properties of which are determined. Once these are known, the determination of the radiation is conceptually a simple problem, although usually mathematical difficulties arise. In the present study, the latter approach is adopted, and the ionosphere is considered as a dissipative media in which the random thermal motions of the charged particles act as a source of the thermal radiation. This random thermal motion of charge can come about in various ways (e.g., due to collision between particles or due to the presence of various kinds of electromagnetic waves propagating in the ionosphere).

The following working model of the ionosphere shall be postulated for the present study. It is assumed to consist of a concentric spherical shell of ionized media in which the temperature, electron density and collision frequency may depend on the altitude, with the presence of the geomagnetic dipole field. It is further assumed that in the ionosphere a linear constitutive relation exists between the a-c conduction current  $\vec{J}_d$  driven by an applied a-c electric field  $\vec{E}$  of the form

$$\vec{J}_d = \overleftrightarrow{\sigma}(\omega, \vec{r}) \cdot \vec{E} \quad , \quad (2.1)$$

where  $\overleftrightarrow{\sigma}$  is a tensor, a function of frequency and position.

A small-signal analysis shall first be considered, followed by consideration of the large-signal analysis.

The following three aspects are to be investigated:

1. Since a fundamental problem in a noise analysis is the determination of the available noise power per unit bandwidth as a function of frequency, an attempt shall be made to obtain the spectral density of the open-circuited noise voltage on the antenna used for the measurement of the thermal noise from the ionosphere.

2. In order to gain a better understanding of the phenomenon the time-space correlation function of the noise source function is to be determined.

3. The calculation of the thermal power radiated from the ionosphere shall be investigated.

2.2.2 Basic Approach. A body at nonuniform temperature is not in thermodynamic equilibrium. However, in those cases in which the distribution function of charge carriers deviates only slightly from the equilibrium distribution (so as to produce heat and current flow), and

this includes all cases for which a temperature can be reasonably defined, it would be expected that the radiated noise power could still be computed as the superposition of the noise power radiated from the various volume elements of the body. In this case each element at a particular temperature radiates the noise power it would radiate at equilibrium at the same temperature. Such an analysis calls for an approach to the fluctuation problem that considers each differential volume element separately as an absorber and emitter of noise power. It calls for the introduction into Maxwell's equations of a source term analogous to the source term of the Langevin equation in the theory of Brownian motion.

Although Maxwell's equations and the constitutive relation are sufficient to solve most electromagnetic problems, they are insufficient for noise studies. The current density derived from the constitutive relations represents only the current derived by the electromagnetic field. Beside this derived current, the current density fluctuation caused by the random motion of the charges must be considered. They can be taken into account by introducing in Maxwell's equations a random driving current density distribution, which is independent of the electromagnetic field. It is, in general, necessary to introduce such Langevin terms for both the magnetic current density and electric current density.

Two cases are to be considered:

1. Maxwell's equations with the Langevin equation.
2. Maxwell's equations with Boltzmann's equation.

### 2.3 Background and Related Materials.

2.3.1 Nyquist Source Treatment. A step toward the determination of the current fluctuation in a linear, dissipative medium has

been taken by Rytov<sup>5</sup>. He considered ordinary conducting media and showed that by postulating some correlations for the current fluctuation in such a media a correct description of the thermal electromagnetic field can be obtained. He also computed (1953) the noise power radiated from a body in free space.

Haus<sup>6</sup> has been able to determine the correlations of the current fluctuation in all uniform linear dissipative media. Vanwormhoudt and Haus<sup>7</sup> have generalized these results to nonuniform media. They include anisotropic media, dissipative media, and a media for which the relationship between the current density and the electromagnetic field is not a local relation. Within certain limits this approach can be used to treat cases with nonuniform temperature distribution. Another attractive feature of such a treatment is the simple relation between the statistical properties of the source fluctuation and the loss characteristics of the medium.

2.3.2 Generalized Nyquist Theorem. (Callen et al.<sup>8,9</sup>) The spectral density of the open-circuit noise voltage of a one-port in thermodynamic equilibrium is proportional to the resistive part of the impedance of the one port. If one denotes by  $\theta$  the temperature of the one port expressed in energy units by means of Boltzmann's constant, then

$$\Phi_o(f) = 2\theta R_o(f) . \quad (2.2)$$

Haus obtained (for a lossy cavity problem),

$$\Phi_n = 2\theta G , \quad (2.3)$$

where  $\Phi_n$  is the spectral operator and G is an operator characteristic of a lossy medium.

The correlation matrix is

$$\Phi_n(\vec{r}, \vec{s}, T) = \left\langle j_n(\vec{r}, t + T) j_n(\vec{s}, t) \right\rangle_{\text{avg.}} \quad (2.4)$$

and the spectral matrix is

$$\Phi_n(\vec{r}, \vec{s}, f) = \int_{-\infty}^{\infty} \Phi_n(\vec{r}, \vec{s}, T) e^{-j2\pi fT} dT \quad (2.5)$$

or

$$\Phi_n(\vec{r}, \vec{s}, f) = \theta [Y(\vec{r}, \vec{s}, f) + Y^+(\vec{s}, \vec{r}, f)] \quad , \quad (2.6)$$

$$\Phi_n(\vec{r}, \vec{s}, T) = \theta [y(\vec{r}, \vec{s}, T) + y(\vec{s}, \vec{r} - T)] \quad . \quad (2.7)$$

Equations 2.6 and 2.7 express the spectral matrix and correlation matrix of the noise current density source in a linear, lossy, electromagnetic medium in thermodynamic equilibrium, where  $y(\vec{r}, \vec{s}, T)$  is the Green's conductivity matrix of the medium.

### 2.3.3 Langevin Equation.

1. The source term of the Langevin equation in the theory of Brownian motion has been discussed by Wax<sup>10</sup>.

2. Rytov<sup>5</sup> has discussed the Langevin equation and the source term for the media in which a linear relationship exists between the a-c conduction current density  $\vec{J}_d$  driven by an applied a-c electric field  $\vec{E}$  of the form

$$\vec{J}_d = \overleftrightarrow{\sigma}(\omega, \vec{r}) \cdot \vec{E} \quad . \quad (2.1)$$

3. An electromagnetic description of the plasma can be made by using either Maxwell's equations and the Boltzmann equation;

$$\nabla \times \vec{H} = \vec{J} + \epsilon_0 \frac{\partial \vec{E}}{\partial t} \quad (2.8)$$

$$\nabla \times \vec{E} = -\mu_0 \frac{\partial \vec{H}}{\partial t} \quad (2.9)$$

$$\frac{\partial f}{\partial t} + \vec{v} \cdot \nabla_{\vec{r}} f + (\vec{E} + \vec{v} \times \vec{B}) \cdot \nabla_{\vec{v}} f = \left( \frac{\partial f}{\partial t} \right)_{\text{coll}}. \quad (2.10)$$

$$\vec{J} = -e \int v f d^3v, \quad (2.11)$$

or by a somewhat less rigorous but a more easily solved set of equations which is a combination of Maxwell's equations and the Langevin equation.

$$\frac{\partial \vec{v}}{\partial t} + \vec{v} \nu = \frac{q}{m} (\vec{E} + \vec{v} \times \vec{B}), \quad (2.12)$$

$$\vec{J} = -n e \vec{v}, \quad (2.13)$$

where  $\nu$  is responsible for damping and is related to the average-momentum transfer collision frequency of the electrons with the other constituent of the plasma. The restrictions and assumptions, which are inherent in the usage of Eq. 2.12 rather than Eq. 2.10, have been discussed by several authors<sup>11,12,13</sup>. For example Eqs. 2.12 and 2.13 can be solved for the current density in terms of the plasma parameter and electromagnetic field (in the form of Eq. 2.1):

$$\begin{pmatrix} J_x \\ J_y \\ J_z \end{pmatrix} = \begin{pmatrix} \sigma_{xx} & \sigma_{xy} & 0 \\ -\sigma_{xy} & \sigma_{yy} & 0 \\ 0 & 0 & \sigma_{zz} \end{pmatrix} \begin{pmatrix} E_x \\ E_y \\ E_z \end{pmatrix}, \quad (2.14)$$

where  $\sigma_{xx} = \sigma_{yy}$ ,  $\sigma_{zz}$ ,  $\sigma_{xy}$  are given<sup>14</sup> as functions of  $\nu$ ,  $\omega$ ,  $\omega_p$ ,  $\omega_H$ , the collision, angular, plasma, and gyro frequencies respectively, and with  $\vec{B} = B_0 \vec{a}_z$  the external magnetic field present.

2.3.4 Thermal Noise. Nyquist<sup>15</sup> derived the spectrum and available power of thermal noise thermodynamically. The Nyquist noise formula for the available power is given by

$$P = k T_e \Delta f \quad , \quad (2.15)$$

where  $k$  is Boltzmann's constant,  $T_e$  is the electron temperature of the plasma and  $\Delta f$  is the bandwidth of the detection system. The treatment based on a microscopic process taking account of collisions of electrons and atomic and molecular components of the plasma resistor are given by Freeman<sup>16</sup>. He derived the power spectrum for a resistor, using the Fourier technique, as

$$P = 4 g k T \left[ \frac{\nu^2}{\nu^2 + 4\pi^2 f^2} \right] \Delta f \quad , \quad (2.16)$$

where  $g$  is the conductance,  $T$  is the temperature,  $\nu$  is the electron collision frequency and  $f$  is the frequency of observation.

In most cases  $L \equiv (\nu^2/\nu^2 + 4\pi^2 f^2) \simeq 1$ , since  $\nu \gg 10^{12}$  for solid-state conductors. However, for a weakly ionized tenuous gas,  $\nu$  may be small enough so that the entire fraction is  $L \leq 1$ .

2.3.5 Coordinate Systems. A spherical coordinate system appears to be a convenient one to use for the present study, e.g., see the coordinate system used by Wait<sup>17</sup> in the "Theory of Schumann Resonances in the Earth-Ionosphere Cavity".

### 3. Propagation of Naturally Occurring Radio Noise Through the Ionosphere.

3.1 Introduction. In recent years there have been many generation mechanisms postulated (e.g., traveling-wave amplification, Cerenkov radiation, and cyclotron radiation) and various theories have been advanced to explain VLF emissions which are a class of natural radio noise

in the frequency range 1 - 30 kc/s. Although no one particular mechanism seems to be able to explain all the observed aspects of VLF emissions some of them appear to be rather successful in explaining the "frequency-time characteristics" of certain types of observed VLF emissions. However, most of these theories, based on linear analyses, appear to predict the radiation intensity of the VLF emission to be much lower than the values actually observed. Since VLF emission propagating through the ionosphere undoubtedly will interact with the ionospheric plasma and affect the observed value of radiation intensity on the ground, it is important to have a good understanding of the detailed characteristics of their propagation. The interaction of the radio noise with the ionosphere may also, in some cases have an effect on a desired radio signal used for communication purposes. For example the Luxemburg-type of effect may become significant under certain circumstances.

It is, therefore, desirable to make a systematic detailed study of the propagation of natural radio noise in the ionosphere. The study of the propagation of a naturally occurring radio noise through the ionosphere is basically that of the interaction of electromagnetic waves with a plasma and can be described in terms of a number of "bulk" parameters of the plasma. These parameters in turn depend upon the basic particle interactions. The interaction of the plasma electrons with neutral atoms, ions, and with one another determines the "collision frequency" of the plasma constituents. The electron density, collision frequency and external forces determine the "conductivity" (and in turn the current density) of a plasma. For a slightly ionized plasma, the conductivity is almost exclusively due to the more mobile electrons. However, for high degrees of ionization the ion conductivity becomes of importance. From a



knowledge of the time and spatial variation of these quantities (electron density, collision frequency and conductivity), the electromagnetic wave interaction with a plasma can, at least in principle, be deduced.

It is well known that the behavior of a plasma can be effectively described, from a microscopic viewpoint, by the Boltzmann equation with the aid of the concept of a density distribution function in phase space. Since the electromagnetic fields are governed by Maxwell's equations, a mathematical description of the interaction between electromagnetic waves and a plasma consists of simultaneous solution of Maxwell's equations and the Boltzmann equation.

Once the existence of VLF natural radio noise propagating along the geomagnetic field lines in the ionosphere in the presence of streams of charge particles is postulated, the following natural questions can be asked:

1. Under what conditions would the radio noise be absorbed or amplified by the ionospheric plasma or by streams of charged particles?
2. What are the saturation points for the absorption and amplification processes of the radio noise, if there are any?

These questions can be answered, at least in principle, by a detailed study of the energy exchange between the radio noise wave and the ionospheric plasma or streams of charged particles. However, it appears that the first of these questions can be answered rather effectively by studying the dispersion relation for the system. To answer the second question requires a study of nonlinear effects which are essential to saturation phenomena, and the techniques developed in nonlinear microwave tube interaction theories are particularly helpful. Furthermore collision effects will undoubtedly play an important role when considering saturation phenomena.

3.2 Statement of the Problem and Basic Approach. This problem is basically concerned with the derivation and analysis of a general non-linear dispersion relationship for the system under consideration. The proposed steps to be taken are indicated as follows:

1. Postulate a realistic working model for the system, e.g., consider a system which may consist of a circularly polarized whistler-mode electromagnetic wave propagating in a relatively cold plasma pervaded by an external magnetic field and gyrating electrons in a stream which penetrates the cold plasma (collision effects being negligible).

2. Derive the nonlinear dispersion relation from Maxwell's equation and the Boltzmann equation with the aid of the auxiliary potential function.

3. Determine the conditions from the derived dispersion relation for the following:

- a. Amplification. (Based on the concept of spatially growing waves, consider complex wave-number with a real frequency in the dispersion relation.)
- b. Plasma instability.
- c. Absorption (Landau damping). (Consider complex frequency with a real wave-number.)

4. Check the obtained result with the existing linear theory, as a special case of our general theory, for the following:

- a. Traveling-wave amplification process (e.g., Gallet and Helliwell<sup>18</sup> or Dowden<sup>19</sup>).
- b. Transverse resonance plasma instability (e.g., Bell and Buneman<sup>20</sup>).
- c. Landau damping of whistlers (e.g., Scarf<sup>21</sup>).

In the present study, the emphasis is placed on the nonlinear analysis. The application of nonlinear microwave tube interaction theories shall be made whenever suitable. The study will be extended to include the collision effects later.

### 3.3 Background and Related Material.

3.3.1 Traveling-Wave Amplification Process. Selective traveling-wave amplification in the outer ionosphere has been postulated by Gallet and Helliwell<sup>18</sup> to explain VLF emission. Although the model used appears to be somewhat artificial, the above postulate seems to be rather successful in general, and several of the phenomena have been at least partially explained. It has been found that the analogy with a small-signal theory of the TWT (Pierce<sup>22</sup>) exists in the case considered by Gallet et al. only under special conditions. It is well known that in the case of a small-signal, single-velocity beam theory, the signal amplification can take place when the phase velocity of the electromagnetic wave,  $v_{ph}$ , is equal to the velocity of the linear electron beam,  $v_o$ . It has been suggested in the literature (Gallet<sup>23</sup>, Gallet and Helliwell<sup>18</sup>) that this is the condition for "VLF emission signal amplification". It should be pointed out that the equality  $v_{ph} = v_o$ , exists only under the condition that the electron plasma angular frequency is much smaller than the wave angular frequency, i.e.,  $\omega_p \ll \omega$ , which is usually true in TWT's. This condition is not generally satisfied in whistler mode propagation (Helliwell and Morgan<sup>24</sup>). Gallet considered the case of both beam and wave traveling along the geomagnetic field line. However, Gallet's TWT process can be generalized by removing the restriction that the electron travels exactly down the field lines. In general, the electron will spiral down the field line and the pitch of the spiral at any position along the field line is determined by the principle of

invariance of the magnetic moment. For the low-energy particles required for this process (at most, a few KeV) the radii of gyration will be much smaller than the extent of the wavefront. Thus, it is the component of particle velocity along the field line or "guiding center velocity" that must be equated to the longitudinal component of the wave phase velocity.

The analogy of this process with the TWT is perhaps closer than envisaged by Gallet and Helliwell. Since their work was published, it has been established by several people that field-aligned columns of ionization can occur in the exosphere (e.g., Smith<sup>25</sup>) and these produce a strong waveguide action in the very low frequency range.

A longitudinal magnetic field is often introduced into the traveling-wave tube to focus the electron beams, and it is the guiding center velocity of the electrons that determines the amplification. As for the laboratory TWT a (signal) longitudinal electric field is required for interaction with the stream. As was pointed out by Gallet et al. a substantial longitudinal component of electric field will exist in the exospheric TWT. It is the phase velocity of this component that is important and for simplicity it is usually assumed that this is  $(c/n)$ , where  $n$  is the refractive index of the medium for strict longitudinal propagation in the extraordinary mode below the gyrofrequency (whistler modes). Thus for guiding-center velocity  $(\beta_d c)$ , the condition for amplification is given by Dowden<sup>19</sup> as  $n\beta_d = 1$ . It should be pointed out that the above amplification conditions must be re-examined when the effect of nonlinear interactions is considered between a wave and a beam with some velocity distribution.

It is interesting to note that in the TWA it is the r-f electric field that does the bunching and the extraction of energy. However, in

the case of cyclotron resonance, bunching is provided by the r-f magnetic field and energy extraction is provided by the r-f electric field. A tube of this latter type will support amplification in both the forward and backward directions.

3.3.2 Transverse Resonance Plasma Instability. There is a type of instability that is due to the resonance between circularly polarized whistler-mode electromagnetic waves propagating in a relatively cold plasma, and the gyrating electrons contained in a stream which penetrates this cold plasma. This type of instability has been suggested by Brice<sup>26</sup> in connection with an explanation of triggered VLF emissions and the theory has been developed by Bell and Bunemann<sup>20</sup>.

Both in laboratory plasmas created in a mirror geometry, and in the earth's exosphere plasma, such a streaming condition may exist, and ionospheric observation of whistler growth may be expected. In whistler-mode propagation the wave frequency is always less than the electron gyro-frequency, and for gyro-resonance to occur it is necessary that the wave and the stream travel in opposite directions. Neufeld and Wright<sup>27</sup>, consider the process of gyro-resonance in the whistler mode for the case in which the stream has zero initial transverse velocity, and conclude that no instabilities exist for transverse electromagnetic wave propagation along the field line when the stream direction opposes that of the wave. This conclusion is plausible on the basis of energy considerations (i.e., the stream will fail to transfer energy to the wave). (It should be kept in mind that the situation analyzed by Neufeld et al.<sup>27</sup> would inevitably result in a longitudinal instability.) However, for streams with finite initial transverse velocity, the analysis of Neufeld et al. must be modified, and Bell and Buneman<sup>20</sup> have demonstrated that a spread of

electron stream velocity in the transverse direction leads to an instability of the stream-plasma system in the whistler mode, with the transverse electron gyration serving as an energy source. Bell and Buneman show that an estimate of phase mixing or Landau damping through longitudinal velocity spread indicates that the phase-mixing effect can suppress the electrostatic (longitudinal) instability without suppressing whistler growth. The basic approach in the theory of Bell and Buneman involves the examination of the dispersion relation for a general distribution function, using the first-order Boltzmann-Vlasov equations for electrons.

The effect of velocity anisotropies in exospheric fast particle fluxes upon the linear dispersion relation for whistler modes has been investigated by Miller<sup>28</sup>. An instability is found when the transverse velocity spread is greater than the longitudinal velocity spread, a condition satisfied by mirroring electron streams. The growth rate is extremely low, however, unless there are a sufficient number of particles traveling at the cyclotron velocity associated with the whistler mode wave. If the wave frequency is too low, the growth rate is negligibly small; while if it is too high, the wave is found to be damped. Typical growth rates are found to be small but not negligible.

3.3.3 Landau Damping of Whistlers. The phenomenon of Landau thermal damping has usually been explained as an energy-transfer mechanism from the organized wave motion to the random motion of the particles which are nearly in phase with the wave. For this reason, significant damping occurs only when the thermal velocity of plasma particles is at most within a couple of orders of magnitude of the phase velocity of the wave. Thus the study of Landau damping has been confined primarily to longitudinal waves in a plasma.

The damping of transverse waves in a collisionless plasma is generally assumed to be negligible. This is because the wave velocity is usually several orders of magnitude greater than the thermal electron velocities. There exists, however, a relatively simple case for which the wave velocity may be reduced below the speed of light by orders of magnitude. This occurs, for a properly chosen radiation frequency, when the plasma is pervaded by an external magnetic field. The Appleton-Hartree theory, which entirely neglects thermal motion, predicts that the index of refraction becomes infinitely large as the radiation frequency is allowed to approach the electron cyclotron frequency as an upper limit. This nonphysical result is due to the complete neglect of random motion under conditions for which thermal effects are important. However, a more accurate theory may easily demonstrate that, for radiation frequencies comparable to the electron cyclotron frequency corresponding to an external magnetic field, the phase velocity of the wave is reduced well below the free-space velocity of light.

It is a well known fact that the ionosphere provides us with an available medium for a detailed study of the Landau absorption mechanism. Although the geomagnetic field is weak by usual standards, it is easily of sufficient magnitude to exhibit a basic role in the absorption process.

For the transverse wave propagating along a magnetic field in a plasma, two circularly polarized modes exist with phase velocities less than the velocity of light for a range of frequency  $\omega$  less than the electron cyclotron frequency  $\omega_H$ . This range includes the whistler modes.  $\Omega_p < \omega < \omega_H$ , where  $\Omega_p$  is the ion cyclotron frequency, down to the very-low-frequency hydromagnetic waves for which  $\omega \ll \Omega_p$ . Consider a wave of

frequency  $\omega$  and wave number  $k$  and note that particles with the cyclotron frequency  $\Omega_H$  travel with a component of velocity  $v_{//}$  along the direction of wave propagation, such that

$$v_{//} = \left( \frac{\omega}{k} \right) \pm \left( \frac{\Omega_H}{k} \right)$$

and are thus in cyclotron resonance with the rotating electric field of the wave. This results in an energy gain by the particle and is the mechanism of Landau damping for such transverse waves. In a plasma, in which the particles have a Maxwellian distribution, a wave with phase velocity  $(\omega/k)$  that lies within an electron thermal velocity  $V_0$  of  $(\Omega_H/k)$  will be heavily damped, as has been discussed by Scarf<sup>21</sup>. However, if  $|(\omega/k) \pm (\Omega_H/k)| > \text{several } V_0$ , the wave will propagate undamped, since a very negligible number of particles will gain energy from the wave.

Scarf<sup>21</sup> investigated the thermal damping of whistlers using the small-amplitude solutions to the coupled Boltzmann-Vlasov-Maxwell's equation. Scarf's small-amplitude theory was re-examined and amplified by Tidman and Jaggi<sup>29</sup> to include Landau damping by fast-particle fluxes, but retaining the linear analysis.

It should be pointed out that the linear theory predicts that the Landau effect manifests itself in a continual absorption of energy from the wave, at a constant rate, for an indefinite period of time. Rand<sup>30</sup> has investigated the particle relativistic effect in Landau damping of transverse waves propagating parallel to an external magnetic field, through a low-density plasma, and predicted a saturation in the absorption process. In this study Rand considers the interaction of an electron with the incident electric and magnetic field by studying the equation of motion with the Lorentz force term, but neglecting the space-charge effect.



Guthart<sup>31</sup> recently has studied the cyclotron absorption of whistler and VLF emissions, based on a linear analysis. In an effort to retain the cyclotron absorption proposal of Scarf<sup>21</sup> as the physical mechanism explaining the high frequency cutoff of noise whistlers, the complex refractive index for a pair of anisotropic electron velocity distributions is evaluated. The transverse velocity distribution in each case is assumed Maxwellian. The first longitudinal distribution of velocities considered is Maxwellian to several mean square velocities and is proportional to  $v^{-1}$ . The cyclotron damping term is then evaluated; however, upon investigation the rate of change of whistler damping with frequency is found to be insufficiently rapid to agree with the observed whistler cutoff. The second velocity distribution considered is a double-humped Maxwellian; i.e., a thermal electron distribution, and a resonant electron stream. This distribution allows for cyclotron absorption and, at the same time, is consistent with the whistler dispersion and attenuation.

The effect of (close range) collisions on Landau damping has been investigated by Platzman and Buchsbaum<sup>32</sup>.

### 3.3.4 Some General Discussion on Plasma Instabilities.

Plasma instabilities and their probable role in ionospheric phenomena have been discussed by Lepechinsky and Rolland<sup>33</sup>. A brief survey is presented in this paper of the important problem of plasma instabilities and of the criteria available for internal instabilities.

The kinematics of growing waves have been discussed by Sturrock<sup>34</sup>.

## 4. Generation of VLF Emissions in the Exosphere by Double-Beam Instability

4.1 Introduction. From the examination of a large quantity of high resolution spectrograms, it has been deduced that a major fraction of

the VLF radio noise (other than whistlers) is excited in the earth's outer ionosphere (exosphere) by streams and bunches of high-speed ionized particles precipitating into the ionized atmosphere in the presence of the earth's magnetic field. The electromagnetic waves excited then propagate in the manner of whistlers<sup>23</sup>. Gallet and Helliwell<sup>18</sup> have suggested that the traveling-wave-tube interaction mechanism, which has received considerable attention during the past few years, is primarily responsible for this noise. However, it is quite possible that other excitation mechanisms are at play; for example, the instability of the beam-plasma system may play an important role. Under the general designation of a two-stream plasma system a great variety of instabilities can be found. It is well known that a plasma consisting of two or more interpenetrating streams of charged particles will be unstable (longitudinal wave will grow spontaneously) if the mean velocity of the particles in one stream is sufficiently great relative to the mean velocity of particles of the other.

The concept of "double-beam instability" or "space-charge-wave amplification effect in the moving interacting charged particle beam" has been used in the electron wave tube<sup>35, 36, 37</sup> and to explain the origin of solar radio noise emission<sup>38</sup> and the abnormal intensity of solar radio bursts<sup>39, 40, 41</sup>.

The principle motivation for the present study is to see if the "double-beam instability" theory, which has been used rather successfully in the solar noise problem, can be extended so as to be applicable to the ionosphere and to see if perhaps this mechanism can be responsible for the generation of VLF emissions in the exosphere. In the ionosphere the analysis is complicated, in general, by the affect of collisions among the particles and by the presence of the magnetic field.

## 4.2 Statement of the Problem

4.2.1 Nature of the Problem. Suppose that at a certain time an undisturbed exosphere region is traversed by a homogeneous electron beam originating from the sun (or from the Van Allen belt). The resulting complex medium may be electrically neutral if either the beam itself also carries positive ions or if the ionospheric ions re-establish neutrality. As the velocity distribution of the electrons is strongly distorted in velocity space, a convective instability can develop; i.e., it has been shown that a beam traversing an isotropic plasma will develop convective instability<sup>33</sup>. This means that if at a certain moment there is a small fluctuation of charge density in the medium, due for instance to a slight local inhomogeneity of the beam, this fluctuation will grow indefinitely while propagating along the beam. Actually its growth will be limited by nonlinear effects, damping and finally by the disruption of the beam<sup>42</sup>. From the phenomenological point of view the instability will appear as a succession of very rapid variations in space and time of the parameters of the medium such as electron density, and current and fields. These variations grow indefinitely while propagating. The onset of nonlinear effects will then change the nature of the disturbance which, instead of remaining purely electrostatic (longitudinal) in nature, will acquire radiation properties and generate an enhanced electromagnetic noise. The noise thus generated will eventually reach the earth, either directly at frequencies above the maximum plasma frequency of the underlying ionosphere or indirectly, by the whistler mode at frequencies below the gyro-frequency, along the magnetic lines of force. However, it must be noted that the noise spectrum should correspond to the instability band of the

interacting beam-plasma, which is to be obtained from the dispersion relation.

Thus the following two-step process is postulated as the generation mechanism for VLF emissions:

1. Space-charge-wave amplification process. (Double-beam instability.)
2. Conversion of the longitudinal space-charge-wave energy into the transverse electromagnetic wave energy.

It should be pointed out that in order to have a good understanding of the above processes, the nonlinear analysis is required.

4.2.2 Formulation of the Problem. The proposed steps for the present study are listed as follows:

1. Study of space-charge-wave amplification process. (Double-beam instability.)
  - a. Derivation of the dispersion relation from the Boltzmann equation and Maxwell's equations for the space-charge wave in a moving electron beam injected into the exospheric plasma.
    - i. Consider the beam with a continuous velocity distribution, and the magnetic field effect is to be included although the collision effect is negligible in the exosphere.
    - ii. Linearized as well as nonlinear dispersion equations are to be considered.
  - b. Determination of the instability band of the interacting beam-plasma system. Solve the dispersion equation numerically and find the condition under which  $\omega$  (angular frequency of space-charge wave) will be complex such that

the time-varying factor of the wave ( $e^{j\omega t}$ ) will grow exponentially.

- c. Investigation of the propagation characteristics of steady-state space-charge waves. Investigate the relationship between the period, amplitude and the phase velocity of the space-charge wave.

2. Study of conversion process from the longitudinal space-charge-wave energy into transverse electromagnetic wave energy. Two possible mechanisms are to be considered.

- a. Mechanism similar to microwave electron tube interaction<sup>39, 43</sup>. Quantitative investigation of energy transfer by a nonlinear analysis is to be made.
- b. Scattering on inhomogeneities in electron density (Rayleigh scattering<sup>44</sup>) similar to that in the generation of solar radio bursts of spectral Type III.

3. Determination of a probable spectral distribution of the VLF emission.

#### 4.3 Background and Related Materials.

4.3.1 Multi-Beam Interaction and Space-Charge-Wave Amplification Effect. The theory of generation of radio energy resulting from space-charge interaction between streams of charged particles has been reviewed and applied by Haeff<sup>37, 38</sup> to the solution of the solar radio noise problem. The space-charge-wave interaction in streams of charged particles results, under certain conditions, in imparting to the space occupied by the streams the characteristic of a medium having negative attenuation. This means that under such conditions an initial fluctuation which may exist in a stream (such as caused by a statistical

fluctuation) will be amplified in an exponential manner as the disturbance propagates along the stream. The amplification process continues until the available energy is exhausted. This energy is derived from the kinetic energy of the particles in the stream so that the energy spectrum of the composite electron cloud will be substantially modified after a prolonged coexistence of streams of different energy. The kinetic energy is thus partially transferred into the energy of the electromagnetic fields associated with the space-charge waves and can be observed as radiation emanating from the streams of charged particles. Using a linear, one-dimensional, single-velocity beam theory Haeff derived the dispersion relation, from which he obtained information on the instability. The instability of this sort is also known as a "double-beam instability".

Because of a rather good agreement between the theoretical results and the observed data for the spectral distribution of the solar radiation, it was believed that a more detailed analysis of the abnormal solar radiation on the basis of Haeff's theory would be profitable.

Feinstein and Sen<sup>39</sup> re-examined and extended the idea of two-beam interaction by Haeff and have discussed the modification introduced by appropriate models of thermal motion. They showed that the possibility of growth of space-charge waves exists even if the beam velocity is less than the thermal velocity. The mechanism available for the conversion of these longitudinal-type oscillations into radiation fields are also investigated and suggest that an electron tube model is applicable provided that the rate of growth of longitudinal oscillation is such as to cause considerable departure from uniformity in amplitude of oscillation. They further pointed out that a quantitative investigation

of energy transfer under these conditions requires a nonlinear theory. Their analysis is based on a linear theory and the examination of a linear dispersion relation in the absence of static magnetic fields and the neglect of the positive ion motion.

Sen<sup>40</sup> undertook the study of a nonlinear theory of space-charge waves in moving, interacting electron beams, and applied the theory to the solution of the solar radio noise problem. He considered the complete equations of interaction (equation of motion, continuity equation and Poisson's equation) without the linear approximation, of two moving single-velocity electron beams of given densities (with a sufficient number of ions to make the charges macroscopically neutral), and showed that the propagation of steady-state space-charge waves is possible in such a medium. The theory is then applied to estimate the relative intensity of the second-harmonic component in solar radio bursts discovered by Wild et al<sup>45</sup>. A theoretical analysis, based on the antenna theory of electromagnetic radiation from an oscillating plasma, gives a radio flux of the order of magnitude of that observed.

The physical mechanism of the two-stream instability for generation of Type III solar radio bursts has been discussed by Malville<sup>41</sup>. In the analysis of microwave electron tubes, it is well known that the space-charge-wave type of analysis, while straight-forward and very useful, by itself is limited in its ability to tie all of the possible interactions together. Two important principles have emerged which have been very successful in pointing out the relation between the various types of interaction. These are the kinetic power theorem<sup>46, 47</sup>, which expresses the power flow along an electron beam associated with the signals, and the coupling of modes of propagation<sup>48, 49, 50</sup>. It has been

shown<sup>46</sup> that the r-f power carried by the beam may be separated into two parts--a kinetic power corresponding to the a-c velocity and an electromagnetic power derived from the Poynting vector  $\vec{E} \times \vec{H}$ . It is of interest to note that it is possible for the kinetic power flow to be negative (power flow in a direction opposite to that of the electron motion), whereas the total power flow must always be positive. For the a-c kinetic power flow to be negative the disturbance must be such that the perturbation in velocity is negative, when the perturbation in the number of particles passing a plane is positive, signifying that more particles of reduced velocity pass the plane than do particles of increased velocity. The time average energy passing the plane is then decreased. Using this argument, it can be shown easily that the kinetic power flow associated with the fast space-charge wave is positive, but that the kinetic power flow associated with the slow space-charge wave is negative. The negative energy of the slow space-charge wave is very important, since this means that it is possible to remove energy from the electron beam by increasing the amplitude of this mode of propagation.

In the double-beam interaction it is the coupling between the fast space-charge wave of a slow electron beam and the slow space-charge wave of fast electron beam which gives rise to an exponentially growing wave. Thus energy can be transferred from the fast electron beam to the slower electron beam<sup>48,49</sup>.

4.3.2 Beam-Plasma Instability. Under the general designation of a two-stream plasma system a great variety of instabilities is found. These occur in non-Maxwellian plasmas<sup>51</sup>, in plasmas with doubly humped distributions<sup>52</sup>, or in distributions with relative drift<sup>53</sup>. Instabilities can also arise because of inhomogeneities in the plasma<sup>54</sup> or in the magnetic field<sup>55</sup>.



Instabilities in plasmas with an injected electron beam are receiving increasing attention. Analysis of a one-dimensional cold-plasma system in the absence of a magnetic field has been given by Neufeld<sup>56,57</sup>. Excitation of a plasma by a beam of finite cross section has also been studied by Sturrock<sup>58</sup> and used as an amplifying mechanism for microwaves<sup>59,60</sup>. Other analyses of beam-plasma interactions with great theoretical detail are also available<sup>61,62</sup>. A study has been made of the instabilities in an ion beam crossing a magnetic field as occurs in the Oak Ridge experiments by Burt and Harris<sup>63</sup>. Instabilities in a plasma-beam system immersed in a magnetic field has been studied by Neufeld and Wright<sup>64</sup>.

A theory of the two-stream ion wave instability in a plasma has been developed by Farley<sup>65</sup> taking into account both the effect of collision of ions and electrons with neutral particles and the presence of a uniform magnetic field. He applied the result to the inner ionosphere and found that irregularities of ionization density should arise spontaneously in regions in which a sufficiently strong current is flowing normal to the magnetic field lines.

An analysis has been made by Neufeld<sup>66</sup> on an instability in a plasma-beam system in which an electron beam aligned along the direction parallel to that of the impressed magnetic field excites transverse waves moving with the beam. When the beam as well as the excited wave by the beam is aligned along the direction of the magnetic field, one obtains a longitudinal as well as a transverse instability. Expressions are derived for frequencies and rates of growth of the transverse waves excited by the beam, from the linear dispersion relation, with a uniform cold plasma under the assumption that the beam as well as the excited wave is aligned along the direction of the magnetic field.

4.3.3 Conversion of Longitudinal Space-Charge-Wave Energy into a Transverse Electromagnetic Radiation.

4.3.3a Microwave Electron Tube Mechanism. The essential features underlying the conversion of longitudinal wave energy of bunched charges into transverse electromagnetic form in electron tubes and multi-stream plasmas have been examined by Feinstein<sup>43</sup>. Criteria for these various modes of conversion are expressed in terms of coincidence in the space and/or time patterns of the two types of waves.

The cavity excited by the bunched beam is designed to produce a large electric field at the frequency of the space-charge wave in the region traversed by the beam for a relatively low energy storage. The wavelength of the two oscillations will generally be quite different under these conditions, although this does not affect the energy transfer because the interaction is confined to a region which is small compared to either wavelength. It is this independence of the wavelengths of the two modes which makes it possible for each to satisfy its own dispersion relation. When the region of interaction extends over many wavelengths, on the other hand, a match is required both in frequency and in wavelength in order for a net interchange of energy to occur. For such a double matching to be in agreement with the dispersion relation for the two modes is a very special condition and so there will normally be no excitation of the transverse mode. An exception arises if a region exists in which the wave characteristic varies considerably within a wavelength or a period. Physically, the electron tube interaction model, or its temporal equivalent, then becomes applicable since the rapidly varying condition permits a net energy delivery with only one of the parameters of the two modes matched. Such a situation can arise

if steep gradients are present in the medium characteristics, as might occur near the edge of prominence eruption, or if the rate of growth of the longitudinal oscillation is such as to cause a considerable departure from uniformity in the amplitude of these oscillations within a wavelength or period. Since the usual calculated growths are very large, this last state of affairs may well provide the answer<sup>39</sup>.

4.3.3b Scattering Process. In connection with sporadic solar radio emission mechanisms, Ginzburg and Zheleznyakov<sup>44</sup> have discussed the transformation of plasma waves into electromagnetic emissions in an isotropic plasma (in the absence of magnetic field). In a homogeneous plasma this transformation occurs only through the scattering of longitudinal waves by fluctuations of the dielectric constant,  $\delta\epsilon \simeq \delta n^2$ , where  $n$  is the refractive index. In an inhomogeneous plasma the efficiency of the transformation is increased due to interactions between plasma and electromagnetic waves whenever the approximation of geometric optics does not apply, in addition to scattering.

In plasma variations of electron concentration which induce the fluctuation,  $\delta\epsilon$  can be represented by  $\delta N = \delta N' + \delta N''$ , where the first term is associated with quasi-neutral plasma density fluctuations,  $\delta\rho_M \simeq M\delta N_+$ , and the second term takes into account the electron density variation that accompanies the electric charge fluctuation  $\delta\rho_e = e\delta N''$ . [Here,  $N_+$  and  $M$  are the concentration and mass of ions (taken as protons).] In view of the inequality  $M \gg m$ ,  $\delta\rho_M$  and  $\delta\rho_e$  can be regarded as statistically independent, thus permitting separate consideration of scattering by density fluctuations and charge fluctuations. (Thus,  $\delta N' = \delta N_+$  and  $\delta N'' = \delta N - \delta N_+$ , where  $\delta N_+$  is the variation of positive particle concentration.) Since the variation of plasma density occurs

quite slowly, scattering by  $\delta\rho_M$  is not accompanied by an appreciable change of wave frequency (Rayleigh scattering).

The time average total energy flux of electromagnetic radiation scattered in volume  $\Delta V$  is given by

$$\Delta P'(\omega) = \frac{n(\omega)\omega^4 E_0^2}{48 \pi^2 c^3} \overline{(\delta\epsilon)^2} (\Delta V)^2, \quad (4.1)$$

where  $E_0$  is the electric amplitude of the transmitted wave,  $n(\omega)$  is the refractive index of the scattered electromagnetic wave  $n^2 = [1 - (\omega_p^2/\omega^2)]$ , and the bar over  $(\delta\epsilon)^2$  denotes averaging over the volume element  $(\Delta V)$ , which has small dimensions compared with the wavelength  $\lambda$ .

In deducing Eq. 4.1, it is usually assumed that scattered electromagnetic radiation arises as an electromagnetic wave propagating in the medium. However, it is easily seen that the entire argument can be applied to the case in which electromagnetic emission results from scattering of the longitudinal wave in the plasma.

#### 4.3.4 Miscellaneous.

##### 4.3.4a Plasma Instability and Ionospheric Phenomena.

Lepechinsky and Rolland<sup>33</sup> have discussed plasma instabilities and their probable role in ionospheric phenomena. They pointed out how the various instabilities may develop and become apparent in the ionosphere due to anisotropies of various kinds such as streams of charged particles, electric fields and electron density discontinuities. Such instabilities may arise spontaneously, for instance, when a plasma cloud driven by the solar wind interacts with the ionosphere, a distortion of the velocity distribution function of the charged particles occurs, eventually creating a second maximum of this function and it is the relaxation of this anisotropy toward equilibrium which is responsible for the oscillations

and radiation. This effect may, in certain circumstances, be actually detected and recorded.

In this report the authors described the various aspects of instabilities in plasmas and indicated a possible classification. They also presented a brief review of the theory of internal instabilities and indicated the corresponding criteria. Finally they showed the natural implication of the various instabilities, e.g., noise generation, ionization irregularities, and their apparent movement, etc.

4.3.4b Mechanism of Injection of Solar Plasma into Magnetosphere. Barthel and Sowle<sup>42</sup> have discussed a mechanism of injection of solar plasma into the magnetosphere. It is shown that the interface between the geomagnetic field and the solar plasma stream is subject to instabilities of the Rayleigh-Taylor type when a solar plasma burst of sufficient intensity and suddenness reaches the magnetosphere following a solar flare. It is also shown that clouds of this plasma can penetrate into the geomagnetic field to perhaps three earth radii and breakup, leaving charged particles in geomagnetic orbits with the energies which are comparable to their directed kinetic energies before penetration.

4.3.4c Magneto-Ionic Theory and VLF Emission. Unz<sup>67</sup> has applied the magneto-ionic theory for drifting plasma to the theory of the origin of very low-frequency emissions. The frequency at which there will be interaction, and possible amplification, between two different streams of electrons is found. It is shown that physical phenomena are explained by interaction between several streams of electrons of different plasma frequency and different velocities. The analysis is based on small-signal, single-velocity beam theory, keeping intact the basic postulate about the traveling-wave amplification in the outer ionosphere.

## 5. Generation of Natural Radio Emission by Plasma-Oscillation

5.1 Introduction. In recent years a great deal of attention has been given to the study of the phenomena of the solar sporadic radio emission (solar radio bursts). The details of the generation of these radio waves and of their subsequent propagation through the solar atmosphere to the earth are not at all clear, but nonlinear and particle-wave interaction phenomena are certainly involved.

A survey of literature on the subject of generation of these radio waves seems to indicate that the majority of radio bursts appear to be explainable by a plasma oscillation which can be induced by various sources, e.g., corpuscular streams, shock wave and magnetohydrodynamic waves, etc. The observation of Type II and Type III meter-wavelength bursts from the sun shows that they drift downward in frequency with time. It is commonly accepted that this drifting results from an agency which moves out through the solar atmosphere, exciting the local plasma frequency as it goes<sup>68,69</sup>.

The drift rate of Type III bursts corresponds to an outward velocity of  $1/4$  to  $1/2$   $c$ , where  $c$  is the velocity of light<sup>69</sup>. The primary agency with this velocity must surely be a stream of charged particles. A two-step process<sup>41,44,70-73</sup> is regarded as generating the radio waves. First, the particles excite longitudinal plasma waves by Cerenkov radiation, and second, the plasma waves are partially converted into transverse waves, which can propagate freely to the earth, by scattering on inhomogeneities in electron density.

The drift rate of Type II bursts corresponds to an outward velocity of 1000 to 1500 km/s<sup>74,75</sup>. It is thought that the primary agency with this velocity is a shock wave. Because the theory of shock

waves and their interaction with the plasma are very involved and incomplete, the theory of Type II bursts is less well developed than that for Type III.

A natural question arises as to whether or not it will be possible to consider that the slower streams of charged particles are the primary agency, rather than the shock wave, for the Type II bursts.

It is, therefore, the purpose of the present study to investigate this very possibility, i.e., to find a mechanism of generation for the Type II bursts, by a stream of slow charged particles, which will enable us to explain most of the outstanding characteristics observed.

5.2 Statement of the Problem. The solar radio bursts of spectral Type II are characterized by a narrow band of intense radiation that drifts toward low frequencies. The magnitude of the drift rate is a function of frequency and at 100 mc/s is about -0.3 mc/s per second. The bursts have a total duration of the order of 10 minutes and generally comprise emissions at a fundamental frequency and a second harmonic.

The desired mechanism, adequately postulated, must be able to explain at least the following outstanding features of the Type II bursts commonly observed<sup>74,75</sup>.

1. Harmonic structure. The bursts usually appear in fundamental and second harmonic bands. The intensities of the first two harmonics are often similar but the third harmonic is considerably less intense. However, there are cases in which one of the harmonics is significantly more intense. The ratio of the peak frequency in the two bands is usually somewhat less than two.

2. Splitting structure (Band splitting). Both fundamental and second harmonic bands are split into two bands each, with separation of the order

of 10 mc/s. This splitting has been thought to be due to a magnetic field and various attempts to explain the splitting have been made generally based on the position of zeros and singularities of the magneto-ionic dispersion equation.

3. Intensity and polarization. Intensities in excess of  $10^{-19}$   $\bar{W} \text{ m}^{-2} (\text{c/s})^{-1}$  are not uncommon. Evidence on the polarization of Type II bursts is very incomplete. However, there are sufficient measurements available to show that these bursts are usually not strongly polarized even for the split-band type of burst.

As a possible mechanism of generation the following two-step process is postulated:

Step I: Plasma oscillations are induced by a stream of slow moving particles.

Step II: Conversion of a longitudinal plasma wave into transverse electromagnetic radiation.

Although there are a variety of ways in which plasma oscillations may be excited, amplified and then converted into electromagnetic radiation and leave the solar atmosphere, the following possibilities shall be investigated:

For Step I: Plasma wave amplification:

Double-stream instability (space-charge-wave amplification).

Instability in the beam-plasma system immersed in magnetostatic field.

For Step II: Conversion process:

Scattering process similar to that used for the explanation of generation of solar radio bursts of Type III.

Microwave electron tube model.



## Coupling between a longitudinal wave and a transverse wave.

The following steps are to be taken:

1. Derivation of the dispersion relation for a properly assumed model of the plasma system with the aid of the Boltzmann equation.
2. Determination of the frequency band of instability (amplification band) from the dispersion relation and comparison with the observed bandwidth.
3. Determination of radiation intensity of the harmonics by considering a steady-state nonlinear plasma oscillation.
4. Calculation of the energy flux spectrum.
5. Explanation of harmonic structure.
6. Explanation of band splitting characteristic with the aid of the dispersion equation.

### 5.3 Background and Related Materials

#### 5.3.1 Solar Radio Bursts

5.3.1a Observational Data. The characteristics of bursts of spectral Type II, recorded with spectral equipment covering the range 40-240 mc/s, have been studied by Roberts<sup>74</sup> in a sample of 65 bursts. Approximately half the bursts show harmonic structure and about half are compound Type III - Type II bursts. Band splitting and the doubling of both the fundamental and second harmonic bands is also relatively common. Statistics are given by Roberts<sup>74</sup> of the rate of occurrence of the bursts, their frequency range, the rate of frequency drift, and harmonic ratio. Some outstanding spectral characteristics are discussed in detail in Reference 74.

Some interpretation of band splitting has been given by Roberts<sup>74</sup>. The close correspondence between the two parts of a split band suggests

that the radiation is produced by a common source emitting at two different frequencies. Further evidence for this view is found in the narrow range of frequency separation observed at any one frequency. Wild<sup>76</sup> and his coworkers suggested that the double-band structure might be the result of magnetic splitting analogous to the Zeeman effect.

Unfortunately the theory of oscillation of a plasma in the presence of a magnetic field is at present somewhat confused. Westfold<sup>77</sup> suggested that such a plasma has three proper frequencies of vibration which are the three frequencies for which the refractive index is zero. On the other hand, Gross<sup>78</sup>, Sen<sup>79</sup> and Bayet<sup>80</sup> have taken the frequencies of plasma oscillation in a magnetic field to be the two frequencies for which the refractive index is very large. It is shown<sup>74</sup> that neither of these theories appear to predict all the observed properties of the split bands. To decide whether the observed doubling of the bands could be the result of magnetic splitting evidently requires the development of a more complete theory, e.g., the extension of the work of Akhiezer and Sitenko<sup>81</sup> and Pine and Bohm<sup>82</sup> to cover the case of a charged particle projected through a plasma which is pervaded by a steady magnetic field. If such a theory should show that oscillations occur at two frequencies separated by approximately the gyro-frequency, then it would support the identification of the observed splitting as magnetic splitting. It was further pointed out that the observed lack of polarization of the splitting band is a further difficulty for this type of theory.

More recently, the spectral observation of solar radio bursts of Type II has been discussed by Maxwell and Thompson<sup>75</sup>. Analysis of the experimental data led them to suggest that the bursts are caused by a disturbance being propagated along a corona streamer in which the

electron density is approximately 10 times that of the Baumbach-Allen model corona. The radial velocity of this disturbance, deduced from a detailed examination of the frequency drift of the bursts, is estimated as 1000 ~ 1500 km/s rather than 500 km/s deduced by Roberts<sup>74</sup>. For the most part the data obtained by Maxwell<sup>75</sup> et al. agree closely with those obtained by Roberts. In Reference 75 some unexplained characteristics of slow-drift bursts, notably with their limited frequency range and the absence of third and higher harmonics, have been discussed. It is pointed out that there is no quantitative explanation for the absence of third and higher harmonics in the spectrum of the Type II bursts. Smerd<sup>83</sup> considered the traveling-wave solution of nonlinear longitudinal electron oscillations in a plasma stream, in the absence of a magnetic field. He suggested that if large oscillations of this kind were responsible for the solar radio bursts, the bursts should be rich in harmonics, and the amplitude of the third and fourth harmonics might be considerable. It must be pointed out, however, that longitudinal oscillation of the plasma in the absence of a magnetic field would give virtually no radio-frequency emission.

5.3.1b Theoretical Work on a Generation Mechanism for Radio Bursts. The possible mechanism responsible for sporadic solar radio emission in an isotropic corona plasma has been discussed by Ginzburg and Zhelezniakov<sup>44</sup> and the noncoherent mechanism of solar radio bursts from the sun in the presence of a magnetic field has also been studied by the same authors<sup>70</sup> based on a linear oscillation theory.

They pointed out that a discussion of the problem of the generation of radio emission by the "disturbed" sun, without taking account of the magnetic field in the corona, is permissible only with reference to

Type II bursts and Type III unpolarized radio bursts. In the case of polarized Type III bursts, enhanced emission, Type IV radio emission, and radio bursts of Type I, the effect of the magnetic field may not be neglected. The effect of the coronal magnetic field on the propagation and emergence of electromagnetic fields from the corona has been discussed by Ginzburg and Zhelezniakov<sup>84</sup>. They further pointed out that the intensification of the waves is intimately related to instabilities and is limited by nonlinear effects, for the case of a reasonably extended system.

The appearance of powerful unpolarized Type II outbursts is due either to the remnants of a prominence erupted from the flare region or to corpuscular streams (with velocity of  $\sim 2 \cdot 10^8$  cm/sec) ejected into the corona simultaneously with the prominence. It may be hypothesized that streams of particles are injected from the region where Type II outbursts are generated from time to time, and the fine structure of the third spectral type in Type II outbursts is related to these corpuscular streams. These corpuscular streams are sometimes ejected during the full duration of a Type II outburst (i.e., for a tenth of a minute). It is obvious that prolonged localization of particles whose speed  $V \geq 5 \times 10^9$  cm/sec in a region with a linear dimension of the order of  $5 \times 10^9 \sim 5 \cdot 10^{10}$  cm is impossible without the presence of a magnetic "trap" frozen in a plasmoid moving out from the site of the flare.

More recently, Cohen<sup>85</sup> has pointed out that the harmonic structure (i.e., the bursts have a second harmonic but not a third) of Type II bursts can be readily explained by a two-step process, as for the Type III bursts, discussed by Ginzburg et al.<sup>44,70</sup>. The splitting of the emission bands in Type II bursts has been thought to be due to a magnetic field. The most plausible suggestion<sup>86</sup> is that the two frequencies

correspond to the extraordinary mode singularities  $\theta = 0$ , and  $\theta = \pi/2$ , where  $\theta$  is the angle between the direction of wave propagation and the magnetic field direction. Waves are generated near these singularities by Cerenkov radiation. These waves correspond closely to plasma waves, and they might be converted into the magneto-ionic modes that can escape to the earth by scattering on the ion components of thermal density fluctuation.

### 5.3.2 Beam-Plasma Interaction.

5.3.2a Space-Charge-Wave Amplification. Haeff<sup>38</sup> has applied the theory of space-charge interaction between streams of charged particles (intermingling streams) to the solution of solar radio noise. Based on a linear one-dimensional, single-velocity beam theory, he derived the dispersion relation and obtained the information on instabilities (amplification). After making some simplifying assumptions he obtained a probable spectral distribution, which is in good agreement with that observed.

Feinstein and Sen<sup>39</sup> extended the idea of Haeff and showed that the possibility of growth exists even if the beam velocity is less than thermal velocity by taking into account the effect of thermal velocity. Sen<sup>40</sup> undertook the study of the nonlinear theory of space-charge waves in moving interacting electron beams by extending Haeff's theory, and applied the theory to the solution of the solar radio noise problem. He considered the complete equation of interaction (equation of motion, continuity equation, and Poisson's equation), without the linear approximation of two moving, single-velocity electron beams and shows that the propagation of steady-state space-charge waves is possible in such a medium. With the aid of a theoretical analysis based on the antenna

theory of electromagnetic radiation from an oscillating plasma, Sen then obtained an estimate of the relative intensity of the second harmonic component of radio bursts. The theoretical result thus obtained indicates agreement within an order of magnitude, with that observed by Wild et al.<sup>76</sup>.

5.3.2b Beam-Plasma Instability. These instabilities can arise because of inhomogeneities in the plasma<sup>54</sup>, or in the magnetic field<sup>55</sup>. Instabilities in the plasma with an injected electron beam have been receiving increased attention. Analysis for a one-dimensional, cold plasma system in the absence of a magnetic field has been given by Neufeld<sup>56,57</sup>. Excitation of a plasma by a beam of finite cross section has also been studied<sup>58</sup> and used as an amplifying mechanism for microwaves<sup>59</sup>. Analysis of beam-plasma interactions with great theoretical detail is also available<sup>61,62,87</sup>.

Instabilities in a plasma-beam system immersed in a magnetic field have been studied by Neufeld and Wright<sup>64</sup>. More recently Neufeld<sup>66</sup> has investigated the interaction of a stationary plasma immersed in a static magnetic field with an electron beam of small intensity. Based on a linear analysis, expressions are derived for frequencies and rate of growth of the transverse waves excited by the beam. Neufeld's analysis involves the investigation of instabilities in a plasma-beam system in which an electron beam aligned in a direction parallel to that of the impressed static uniform magnetic field excites transverse waves moving with the beam. A cold, uniform plasma was assumed to be comprised of electrons and singly charged ions. Certain characteristic features of the plasma-beam interaction have been analyzed<sup>64</sup>. It was shown<sup>66</sup> that when the beam as well as the plasma excited by the beam is assumed to be aligned along the direction of the magnetic field, one obtains a longitudinal and a transverse instability.

### 5.3.2c Conversion Process by Scattering. The

generation of plasma waves in the isotropic chromosphere and corona (in nonmagnetic plasmas) is of interest in connection with sporadic solar radio emission only when these longitudinal waves can be efficiently transformed into transverse (radio) waves. In a homogeneous plasma this transformation occurs only through the scattering of longitudinal waves by fluctuation of the dielectric constant,  $\delta\epsilon \simeq \delta n^2$  (where  $n^2 \simeq 1 - \omega_p^2/\omega^2$ ). There are two types of scattering of interest--Rayleigh scattering and combinational scattering, both of which have been discussed in detail by Ginzburg et al.<sup>44</sup>.

In an inhomogeneous plasma the efficiency of the transformation is increased due to interactions between the plasma and electromagnetic waves wherever the approximation of geometric optics does not apply, in addition to scattering.

It should be pointed out that Rayleigh scattering produces no change in frequency and therefore plays no role in determining the bandwidth of the escaping radiation. Combinational scattering, on the other hand, involves the scattering of the excited waves by the plasma waves carried by the electron density fluctuations of the medium; the bandwidth of the scattered waves will be approximately the sum of the bandwidth of the two waves. The bandwidth of the second harmonics generated by combination scattering may be larger than that of the fundamental.

### 5.3.2d Conversion Process by a Microwave Electron

Tube Model. Feinstein and Sen<sup>39</sup> proposed a mechanism of energy conversion from the longitudinal oscillation to transverse electromagnetic waves. They suggested that the electron tube model can be used when the

rate of growth of longitudinal oscillations is such as to cause considerable departure from uniformity in the amplitude of oscillation, and pointed out that a quantitative investigation of energy transfer under these conditions requires a nonlinear theory.

Feinstein<sup>43</sup> has examined qualitatively the features underlying the conversion of the longitudinal wave energy of bunched charges into transverse electromagnetic form in electron tubes and multi-stream plasmas.

Sturrock<sup>88</sup> has studied the interaction between longitudinal (electrostatic) and transverse (electromagnetic) waves in plasmas. The effect of nonlinear terms in the dynamic equation governing wave propagation in the plasma was analyzed by a perturbation procedure which is acceptable for amplitudes which are not too large. His calculation indicates the possibility of explaining why emission is observed predominantly at the fundamental and at the second harmonic as observed by Wild et al.<sup>76</sup>.

### 5.3.3 Radiation from Plasma.

5.3.3a Radiation from Moving Sources. Electrons moving in an isotropic plasma with velocities greater than their average thermal velocity lose energy mainly through collision with plasma particles. Bremsstrahlung results from close electron encounters. The Vanilov-Cerenkov effect is absent for electromagnetic waves in an isotropic plasma (nonmagnetic plasma) because the square of the refractive index of electromagnetic waves

$$n^2 \simeq \epsilon \simeq \left( 1 - \frac{\omega_p^2}{\omega^2} \right) \quad (5.1)$$

is always less than unity (here  $\omega_p$  is the frequency of normal plasma oscillation,  $\epsilon$  is the dielectric constant). Therefore in an isotropic



plasma, in addition to Bremsstrahlung plasma waves can be generated corresponding to distant encounters between electrons and other particles of the medium. These plasma waves are of interest to us because they can be transformed into electromagnetic waves and thus contribute to radio emission of the plasma.

The generation of (longitudinal) plasma waves through the motion of a fast electron in an isotropic plasma is the Vanilov-Cerenkov effect for these waves. Plasma waves with the frequency<sup>44</sup>

$$\omega = (\omega_p^2 + 3 v_T^2 k^2)^{1/2} \quad (5.2)$$

(kinetic approximation) are emitted in the direction forming an angle  $\theta$  with the electron velocity  $\vec{v}$  that is given by the condition

$$\beta n_3 \cos\theta = \frac{kv}{\omega} = 1, \quad (5.3)$$

where  $v_T = \sqrt{KT/m}$  ( $K$  is the Boltzmann constant),  $\vec{k}$  is the wave number,  $\beta \equiv v/c$ , and  $n_3$  is the refractive index of the plasma, and it has been assumed that  $v_T k \ll \omega_p$  [or equivalently  $\lambda/2\pi \gg D$ , where  $D = (KT/4\pi e^2 N)^{1/2}$  is the Debye radius]. In the region where  $v_T k \ll \omega_p$ , plasma waves are weakly damped, and one has

$$n_3^2 \equiv \frac{c^2 k^2}{\omega^2} \equiv \frac{\epsilon}{3\beta_T^2}, \quad (5.4)$$

where

$$\beta_T \equiv \frac{v_T}{c}.$$

Abele<sup>89</sup> has calculated the electromagnetic and acoustic fields as well as the spectral distribution of radiated energy, for a linear charge moving either in an infinite compressible plasma, or exterior and parallel to the surface of a plasma half-space.

Cohen<sup>71</sup> carried out a similar treatment for a point charge in an infinite compressible plasma. Tuan and Seshardri<sup>90</sup> have calculated the radiation from a moving line charge in a uniaxially anisotropic medium ( $\omega_c = \infty$ , where  $\omega_c$  is cyclotron angular frequency) and have obtained expressions for the spectral distribution of the radiated energy; see also Johnson<sup>91</sup>. In contrast to the case of an isotropic medium a radially expanding spherically symmetric shell of charge may radiate in an anisotropic plasma. For a high-velocity burst, Ford<sup>92</sup> has calculated the radiation fields and spectral distribution of energy in the low-frequency range  $\omega \ll \omega_c, \omega_p$  and he finds that the radiation is confined within a narrow cone about the direction of the external magnetic field.

5.3.3b Radiation by Plasma Oscillation. The generation of radio noise by plasma oscillations has been the subject of considerable attention recently<sup>93-98</sup>. Interest in this mechanism grew from the suggestion by Shklovsky<sup>99</sup> that some radio bursts from the sun had their origin in coronal plasma oscillation. The plasma oscillations were assumed to be excited by the propagation of a disturbance through the corona. One of the prevalent features of Type II and Type III solar noise spectra is the appearance of a second noise band at about twice the plasma frequency<sup>74</sup>. This feature has been taken as strong evidence that this radio noise does have its origin in a plasma oscillation mechanism.

The calculations of radio emission by plasma oscillations have been made by various workers; Field<sup>93</sup> showed that the plasma mode and the electromagnetic mode could couple when a density or temperature gradient was sustained in the plasma, or when a static magnetic field was present, and calculated the radiation from plasma oscillations incident on a

density discontinuity. The problem of radiation by plasma oscillations propagating across a density discontinuity has since been treated more fully by Tidman and Boyd<sup>94</sup>. Gould<sup>95</sup>, using the same moment equations as Field, relaxed the condition of a density step and considered density variations characterized by a small parameter  $\epsilon$  to determine the energy radiated to the first order in  $\epsilon$ . Tidman<sup>96</sup> used a more exact set of moment equations (neglecting only moments higher than the second) and calculated the noise generated when the plasma oscillations propagate in the presence of slowly varying gradients using a WKB approach. The latter work by Tidman and Weiss<sup>97</sup> made use of the collisionless Boltzmann equation to consider gradients of arbitrary scale length and compared their results with those from calculations based on the moment equations. The same workers<sup>98</sup> have used second-order perturbation theory to estimate the amount of energy radiated by a plasma oscillation localized in a zero-temperature plasma. They found that coupling of longitudinal and transverse modes enters the linear theory in such a way that radiation is emitted at twice the plasma frequency.

The generation of radio noise by plasma oscillations has been studied by Boyd<sup>100</sup>, making use of the collisionless Boltzmann equation to describe the electron components of the plasma. A second-order perturbation calculation is performed to determine the power spectrum for radiation at the second harmonic of the plasma frequency in a hot plasma in which there is no external magnetic field and the ions are of uniform density. The approach used by Boyd is as follows. The electron distribution function  $f(\vec{r}, \vec{v}, t)$  and the electric field  $\vec{E}$  and magnetic field  $\vec{H}$  satisfy the set of Maxwell's equation and the Vlasov equation (collisionless Boltzmann equation). Considering small perturbations about an equilibrium state of the electron gas,

$$f(\vec{r}, \vec{v}, t) = f_0(\vec{v}) + f_1(\vec{r}, \vec{v}, t) + f_2(\vec{r}, \vec{v}, t) \quad , \quad (5.5)$$

$$\vec{E} = \vec{E}_1(\vec{r}, t) + \vec{E}_2(\vec{r}, t) \quad , \quad (5.6)$$

$$\vec{H} = \vec{H}_1(\vec{r}, t) + \vec{H}_2(\vec{r}, t) \quad . \quad (5.7)$$

Upon substituting Eqs. 5.5 - 5.7 into the Maxwell and Vlasov equations, a set of first-order equations and a set of second-order equations are obtained. Then take a Fourier space transform and a Laplace time transform of the set of second-order equations. Assuming that the initial perturbation is entirely first order; and setting  $\vec{H}_1$  equal to zero to simplify the algebra, (and assuming  $\vec{E}_1$  is purely longitudinal) the solution of the set of first-order equations can be determined once  $f_0$  is known, and the solution of the set of second-order equations can be obtained once  $\vec{E}_1$  and  $f_1$  are known. A far-field approximation is made, and asymptotic expressions for the second-order fields are obtained. Using the Poynting vector the calculation of the energy flux spectrum is made.

## APPENDIX A. BOLTZMANN EQUATION ANALYSIS

The ionosphere presents an environment in which the close collisions of electrons are frequently not very important, with the consequence that the collisionless Boltzmann equation interpreted in the sense of Landau and Vlasov may be expected to have considerable relevance. Boltzmann's equation describing the evolution of the electron density function  $f(\vec{x}, \vec{v}, t)$ --the number of electrons per unit volume of phase space--is

$$\frac{\partial f}{\partial t} + \vec{v} \cdot \frac{\partial f}{\partial \vec{x}} + \vec{a} \cdot \frac{\partial f}{\partial \vec{v}} = \left( \frac{\partial f}{\partial t} \right)_{\text{collision}} . \quad (\text{A.1})$$

If the effect of close collisions is ignored, and the acceleration  $\vec{a}$  is evaluated in terms of the smeared-out electric field arising from the charge distribution, so that

$$\vec{a} = - \frac{e}{m} \vec{E} , \quad (\text{A.2})$$

the Landau-Vlasov equation is obtained.

Since  $\vec{E}$  depends on  $f$ , Eq. A.1 is nonlinear and, apart from a few special solutions, can only be dealt with by using a perturbation theory or resorting to numerical integration. It is the latter course which will be followed here. For simplicity, a one-dimensional treatment will be given. This is not an inherent limitation of the approach from a purely mathematical point of view, but may prove to be so when the cost of multi-dimensional computer calculations is considered.

The equation on which the analysis will be founded is therefore

$$\frac{\partial f}{\partial t} + v \frac{\partial f}{\partial x} + a \frac{\partial f}{\partial v} = 0 . \quad (\text{A.3})$$

A similar equation is valid for the ions, but it is sufficient to carry through the argument for the electrons since the only coupling occurs through the force term appearing in the acceleration. The force will be evaluated subsequently from Poisson's equation. (The quasi-static approximation is implicit in the use of Poisson's equation.)

If a closed volume is considered, it is clear that, although the distribution of particles entering this volume can be specified, the distribution of those which leave it cannot be specified a priori. In other words, the boundary conditions in both space and velocity can only be specified for incoming particles. In the one-dimensional case it is convenient to think of a left-hand boundary at  $x = 0$  and a right-hand boundary at  $x = d$ . The distribution function may then be given for positive velocities at the left boundary and for negative velocities at the right boundary. It is convenient to define velocity moments  $M_k^+$  and  $M_k^-$ , over the positive and negative velocities, respectively, as follows:

$$M_k^\pm = \pm \int_0^{\pm\infty} v^k f \, dv \quad . \quad (\text{A.4})$$

From Eq. A.3 it follows that

$$\frac{\partial M_k^\pm}{\partial t} + \frac{\partial M_{k+1}^\pm}{\partial x} - ka M_{k-1}^\pm = \begin{cases} \pm a f(x, 0, t) & ; k = 0 \\ 0 & ; k \neq 0 \end{cases} \quad . \quad (\text{A.5})$$

An orthogonal polynomial expansion is made for  $f(x, v, t)$  at this stage.

$$f(x, v, t) = w^\pm(v) \sum_{k=0}^{n-1} a_k^\pm(x, t) P_k^\pm(v) \quad , \quad (\text{A.6})$$

where the polynomials  $P_k^\pm(v)$  of degree  $k$  in  $v$  are orthonormal with respect to the weighting function  $w^\pm(v)$  over the range  $(0, \pm\infty)$ . For an exact

representation of  $f$ , an infinite series is needed in Eq. A.6, however, an  $n$ th order approximation can be made by assuming  $a_k = 0$  for  $k \geq n$ .

If the coefficients  $C_{k,l}^{\pm}$  of the  $k$ th polynomial are defined by

$$P_k^{\pm}(v) = \sum_{l=0}^k C_{k,l}^{\pm} v^l, \quad (\text{A.7})$$

the term on the right-hand side of Eq. A.5 for  $k = 0$  becomes

$$f(x,0,t) = \left[ \frac{C_{n-1,n-1}}{C_{n,n}} \sum_{k=0}^n (C_{n,k+1} C_{n+1,0} - C_{n-1,k-1} C_{n,0}) M_k \right]^{\text{sgn}(-a)}. \quad (\text{A.8})$$

The term  $\text{sgn}(-a)$  implies that the positive expansion is used for all coefficients when the acceleration is negative, and vice versa. This choice arises from consideration of the boundary conditions in velocity space. Particles can only enter across the boundary  $v = 0$ . Thus, for example, the particles entering the positive velocity region (and therefore having positive acceleration) must originate as particles leaving the negative velocity region. Therefore, the value of  $f(x,0,t)$  determined from the negative velocity region must specify  $f(x,0,t)$  on the boundary  $v = 0$  of the positive velocity region.

One more equation arises from an identity satisfied by virtue of the truncated polynomial expansion

$$M_n^{\pm} = - \frac{1}{C_{n,n}^{\pm}} \sum_{k=0}^{n-1} C_{n,k}^{\pm} M_k^{\pm}. \quad (\text{A.9})$$

In order to get the partial differential equations in standard form for computation, a linear transformation of the moments is made of the form

$$m_i^\pm = \sum_{j=0}^{n-1} \alpha_{ij}^\pm M_j^\pm . \quad (\text{A.10})$$

If, in addition, Laguerre polynomials  $L_k(\pm v)$  are used which are orthogonal with respect to the weighting functions  $w^\pm(v) = e^{\mp v}$  over  $(0, \pm \infty)$ , the resulting equations are

$$\begin{aligned} \frac{\partial m_k^\pm}{\partial t} \pm \lambda_k \frac{\partial m_k^\pm}{\partial x} = & \pm a \left[ \left( \frac{\lambda_k - 1}{2\lambda_k} \right) m_k^\pm - \sum_{\substack{j=0 \\ j \neq k}}^{n-1} \frac{m_j^\pm}{\lambda_k - \lambda_j} \right] \\ & + a \frac{(-1)^{(n \mp n + (n-1)[1 - \text{sgn}(-a)])/2}}{\lambda_k} \sum_{j=0}^{n-1} m_j \text{sgn}(-a) \end{aligned}$$

$$k = 0, 1, 2 \dots n - 1 . \quad (\text{A.11})$$

The parameters  $\lambda_0, \lambda_1 \dots \lambda_{n-1}$  are the zeros of the  $n$ th order Laguerre polynomial. These are the equations programmed on the computer. The initial conditions of  $m_k^\pm$  are obtained from the moments of the boundary conditions and the transformation Eq. A.10.

So far the nonlinearity of the equation which arises in the acceleration term has not been introduced explicitly. This term will now be considered in the case of an electron-ion model of a plasma which has particle density functions  $f_e$  and  $f_i$  respectively. The basic equations are

$$\frac{\partial f_e}{\partial t} + v \frac{\partial f_e}{\partial x} - \frac{e}{m_e} E \frac{\partial f}{\partial v} = 0 , \quad (\text{A.12})$$

$$\frac{\partial f_i}{\partial t} + v \frac{\partial f_i}{\partial x} + \frac{e}{m_i} E \frac{\partial f}{\partial v} = 0 , \quad (\text{A.13})$$



in which the electric field  $E(x,t)$  is determined from Poisson's equation,

$$\frac{\partial E}{\partial x} = \frac{e}{\epsilon_0} \int_{-\infty}^{\infty} [f_i(x,v',t) - f_e(x,v',t)] dv' \quad . \quad (A.14)$$

If  $V_d$  is the potential of the boundary  $x = d$  with respect to the potential of  $x = 0$ , Eq. A.14 can be integrated to obtain  $E$ :

$$E(x,t) = \frac{e}{\epsilon_0} \int_0^x \int_{-\infty}^{\infty} [f_i(x',v',t) - f_e(x',v',t)] dv' dx' - \frac{e}{\epsilon_0} \int_0^d \int_0^{x''} \int_{-\infty}^{\infty} [f_i(x',v',t) - f_e(x',v',t)] dv' dx' dx'' - \frac{V_d}{d} \quad . \quad (A.15)$$

In order to reduce the number of independent parameters to a minimum, normalization of the variables has to be carried out. There are two main factors influencing the form of the normalization.

1. Since both particle species interact continuously, the same time scale must be used for both equations.

2. The inequality  $m_e/2kT_e \ll m_i/2kT_i$  is always satisfied under realistic circumstances (essentially, the thermal velocity of the electrons is much greater than that of the ions) and in order to get an adequate representation of the density functions it is desirable to have different scales for the velocities in the electron and ion equations.

An unavoidable consequence of (1) above is that the ions move very slowly on a time scale which will adequately describe the motion of the electrons, and so many steps of computation are required to follow the motion completely. A convenient normalization arrived at, bearing the above factors in mind, is as follows:

$$v = \mu \left( \frac{2kT_e}{m_e} \right)^{1/2} \tilde{v}_e = \mu \left( \frac{2kT_i}{m_i} \right)^{1/2} \tilde{v}_i ,$$

$$x = d\tilde{x} ,$$

$$t = \frac{d}{\mu} \left( \frac{m_e}{2kT_e} \right)^{1/2} \tilde{t} ,$$

$$f_e = \frac{m_e \epsilon_0}{e^2 d^2} \cdot \frac{\mu}{2} \cdot \left( \frac{2kT_e}{m_e} \right)^{1/2} \tilde{f}_e ,$$

$$f_i = \frac{m_i \epsilon_0}{e^2 d^2} \cdot \frac{\mu}{2} \cdot \left( \frac{2kT_i}{m_i} \right)^{1/2} \frac{T_e}{T_i} \tilde{f}_i ,$$

$$E = \frac{\mu^2 kT_e}{ed} \tilde{E}$$

$$V_d = \frac{\mu^2 kT_e}{e} \tilde{V}_d . \quad (\text{A.16})$$

In these equations  $\mu$  is an arbitrary constant parameter which is chosen to optimize the numerical approximation of the boundary conditions. The normalized equations are

$$\frac{\partial \tilde{f}_e}{\partial \tilde{t}} + \tilde{v}_e \frac{\partial \tilde{f}_e}{\partial \tilde{x}} - \tilde{E} \frac{\partial \tilde{f}_e}{\partial \tilde{v}_e} = 0 , \quad (\text{A.17})$$

$$\frac{\partial \tilde{f}_i}{\partial \tilde{t}} + \left( \frac{m_e T_i}{m_i T_e} \right)^{1/2} \left[ \tilde{v}_i \frac{\partial \tilde{f}_i}{\partial \tilde{x}} + \frac{T_e}{T_i} \tilde{E} \frac{\partial \tilde{f}_i}{\partial \tilde{v}_i} \right] = 0 , \quad (\text{A.18})$$

$$\begin{aligned} \tilde{E} = & \int_0^{\tilde{x}} \left( \int_{-\infty}^{\infty} \tilde{f}_i d\tilde{v}_i - \int_{-\infty}^{\infty} \tilde{f}_e d\tilde{v}_e \right) dx' \\ & - \int_0^1 \int_0^{\tilde{x}''} \left( \int_{-\infty}^{\infty} \tilde{f}_i d\tilde{v}_i - \int_{-\infty}^{\infty} \tilde{f}_e d\tilde{v}_e \right) d\tilde{x}' d\tilde{x}'' - \tilde{V}_d . \quad (\text{A.19}) \end{aligned}$$

As an example of the type of calculation which can be performed, an interpenetrating ion and electron stream will be considered. Suppose that there is a source of electrons at  $x = 0$  with positive streaming velocities which have a half-Maxwellian distribution with temperature  $T_e$ , and at  $x = d$  there is an ion source with negative streaming velocities which have a similar distribution of temperature  $T_i$ . The boundary conditions are

$$f_e(0, v, t) = \frac{J_e m_e}{kT_e} \exp(-m_e v^2 / 2kT_e) ; \quad v \geq 0 , \quad (\text{A.20})$$

$$f_e(d, v, t) = 0 ; \quad v < 0 , \quad (\text{A.21})$$

$$f_i(0, v, t) = 0 ; \quad v > 0 , \quad (\text{A.22})$$

$$f_i(d, v, t) = \frac{J_i m_i}{kT_i} \exp(-m_i v^2 / 2kT_i) ; \quad v \leq 0 , \quad (\text{A.23})$$

$$f_i(x, v, 0) = f_e(x, v, 0) = 0 ; \quad \text{all } v, 0 \leq x \leq d . \quad (\text{A.24})$$

The last condition states that no particles are present initially. In terms of the normalized variables, Eqs. A.20 to A.24 become

$$\tilde{f}_e(0, \tilde{v}_e, \tilde{t}) = N_e e^{-\mu^2 \tilde{v}_e^2} ; \quad \tilde{v}_e > 0 , \quad (\text{A.25})$$

$$\tilde{f}_i(1, \tilde{v}_i, \tilde{t}) = N_i e^{-\mu^2 \tilde{v}_i^2} ; \quad \tilde{v}_i < 0 , \quad (\text{A.26})$$

where

$$N_\alpha = \frac{8}{9\mu} \left( \frac{eV_d}{kT_e} \right)^{3/2} \left( \frac{T_e}{T_\alpha} \right)^{1/2} \frac{J_\alpha}{J_{\alpha d}} ; \quad \alpha = i, e \quad (\text{A.27})$$

and

$$J_{\alpha d} = \frac{4 \epsilon_0}{9} \left( \frac{2e}{m_\alpha} \right)^{1/2} \frac{V_d^{3/2}}{d^2} . \quad (\text{A.28})$$

$\mu$  is determined by requiring that the right-hand side of Eq. A.8 should yield exactly the specified boundary values at  $v = 0$  in Eqs. A.20 and A.23. The five remaining disposable parameters are therefore

$$\frac{m_i}{m_e} , \quad \frac{T_e}{T_i} , \quad \frac{J_i}{J_{id}} , \quad \frac{J_e}{J_{ed}} , \quad \frac{eV_d}{kT_e} .$$

An example showing the ion and electron currents at various planes as they change with time is shown in Figs. A.1 and A.2. In this case

$$\frac{m_i}{m_e} = 1000, \quad \frac{T_e}{T_i} = 3 , \quad \frac{J_i}{J_{id}} = \frac{J_e}{J_{ed}} = 0.3536 , \quad \frac{eV_d}{kT_e} = 2.0 .$$

The normalized unit of time in both figures may be interpreted as being approximately the transit time for an electron with the average electron thermal velocity. It can be seen that the electrons virtually arrive at a state of equilibrium after about two transit times.

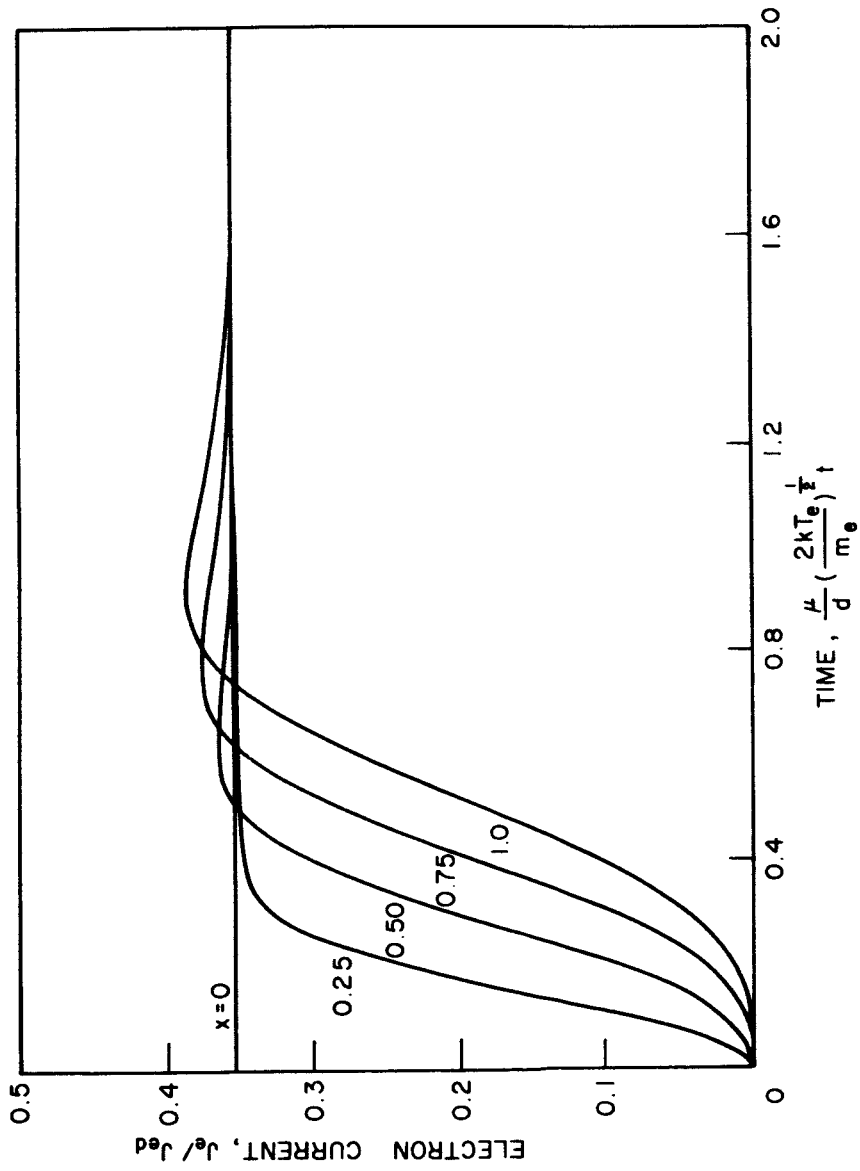

FIG. A.1 INTERPENETRATING ION AND ELECTRON STREAM. PLOT OF ELECTRON CURRENT AT VARIOUS PLANES.

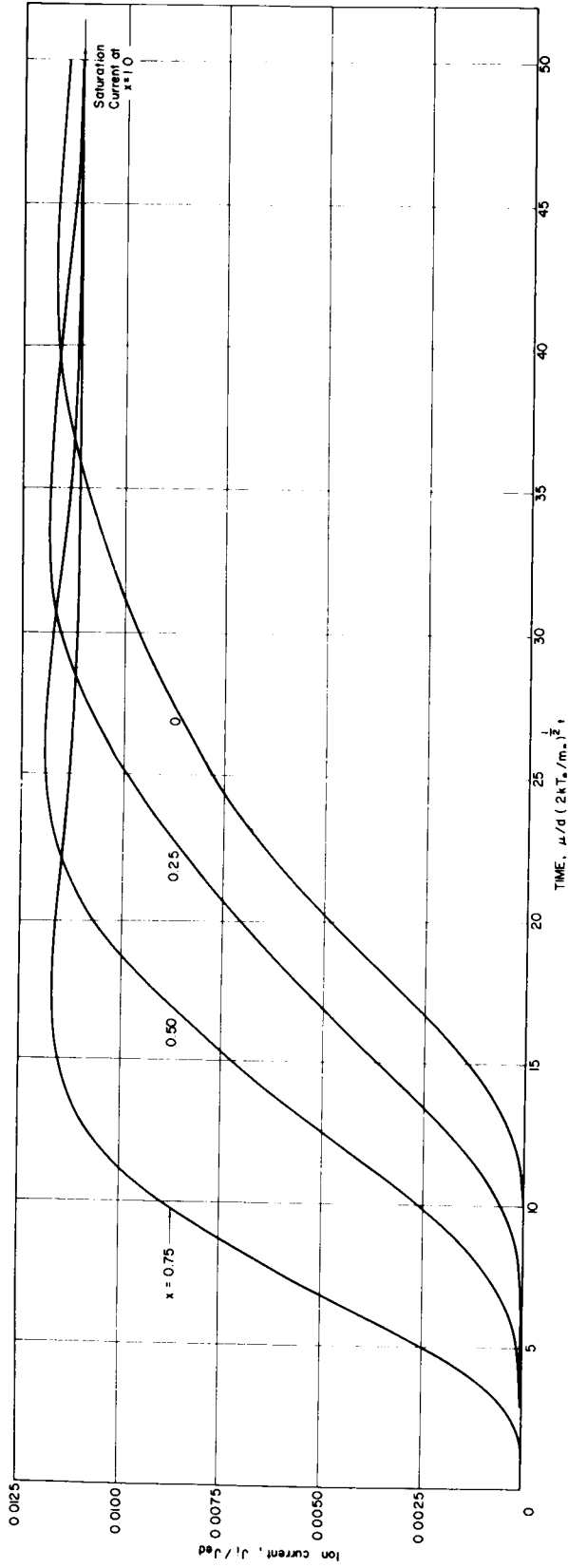

FIG. A.2 INTERPENETRATING ION AND ELECTRON STREAMS. PLOT OF ION CURRENT AT VARIOUS PLANES. (NOTE THAT THE CURRENT IS NORMALIZED WITH RESPECT TO  $J_{ed}$  IN THIS PLOT IN ORDER TO MAKE DIRECT COMPARISON WITH FIG. A.1 POSSIBLE.)

## APPENDIX B. LAGRANGIAN ANALYSIS

### 1. Introduction

The subject of nonlinear beam-plasma-electromagnetic wave interaction phenomena has become of great interest in ionospheric propagation studies recently as a result of experimental findings in such areas as VLF emissions. An understanding of the essential features of particle-wave interactions in anisotropic media requires a general nonlinear analysis in order to calculate energy transfer between system constituents. A general Lagrangian nonlinear analysis is outlined here and applied to the beam-plasma system.

The Lagrangian method allows for trajectory crossovers, and multi-dimensional effects are easily included. The basis of the formulation is the integration of the equations of motion along a dynamical trajectory, summing all forces acting on representative charge groups injected at some initial plane. Finite temperature plasmas and beams are easily included by specifying appropriate distributions in velocity-phase space.

### 2. Nonlinear Equations for Combined One-Dimensional Beam-Plasma and Circuit

The general nonlinear Lagrangian theory developed here applies to the model illustrated in Fig. B.1 where either beam may be made up of electrons or be an ideal plasma. The combination might also be surrounded by a wave propagating circuit. A one-dimensional finite-diameter axially symmetric system is assumed. The plasma field is also assumed to be fully ionized and any effects of neutrals on the interaction process

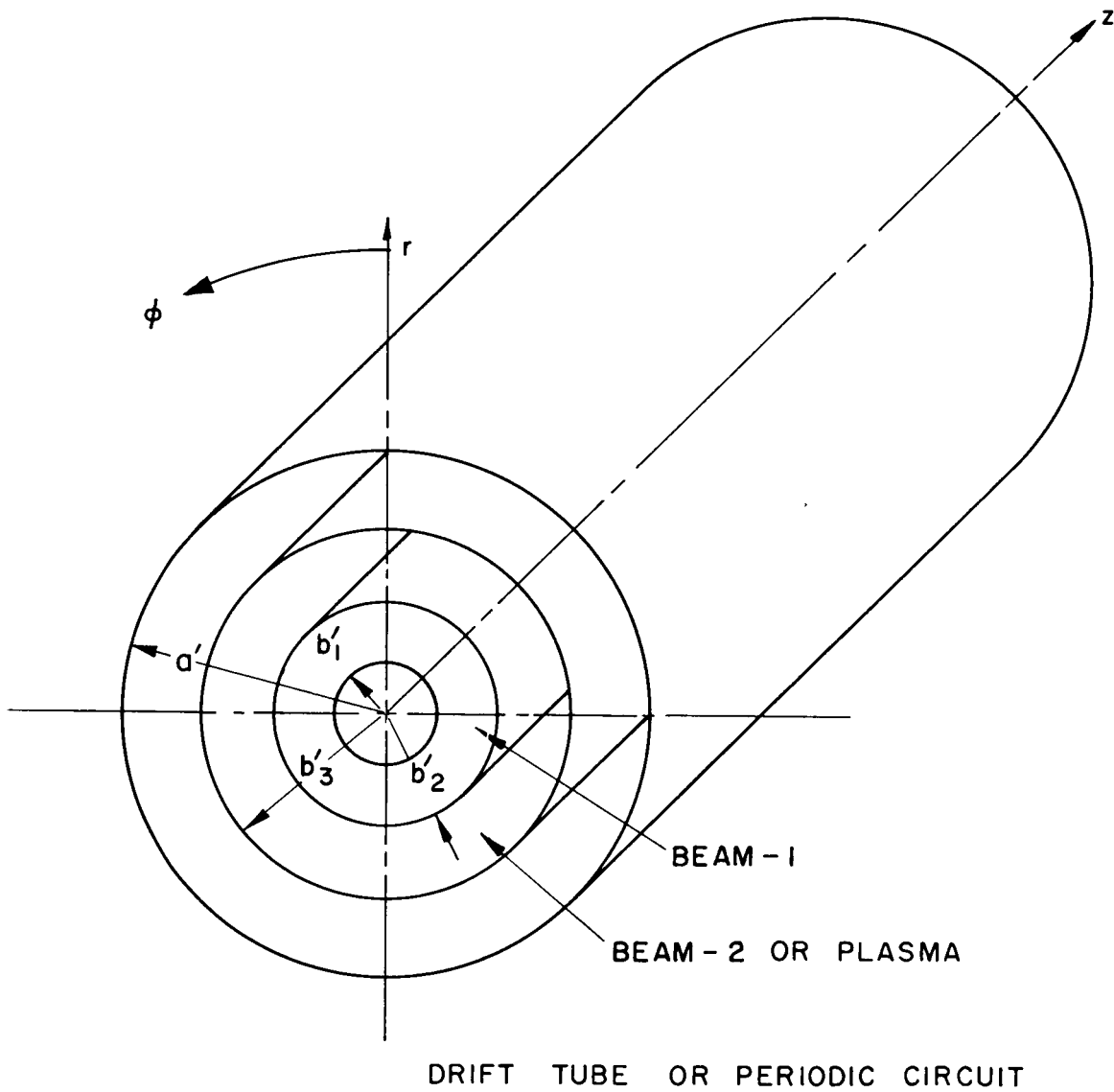

FIG. B.1 BEAM-PLASMA-CIRCUIT INTERACTION CONFIGURATION.



is neglected. Nonrelativistic particle and wave velocities are also assumed.

2.1 Definitions. Since it is desired to allow each of the charge fields of Fig. B.1 to have an arbitrary sign we define appropriate charge-to-mass ratios as

$$\eta_1 \triangleq \epsilon_1 |\eta_1|$$

and

$$\eta_2 \triangleq \epsilon_2 |\eta_2| , \quad (\text{B.1})$$

where  $\epsilon_1, \epsilon_2 = \pm 1$  according to the negative or positive charge of the particular field. The following fundamental definitions pertain to combined charge-to-mass ratios and the respective "charge field" currents.

$$\eta_0 \triangleq \frac{|\eta_1| + |\eta_2|}{2} , \quad \eta_0 > 0$$

and

$$\eta' \triangleq \frac{|\eta_1| - |\eta_2|}{2\eta_0} , \quad -1 < \eta' < 1 . \quad (\text{B.2})$$

The static field currents are given by

$$I_{01} = \epsilon_1 |I_{01}|$$

and

$$I_{02} = \epsilon_2 |I_{02}| . \quad (\text{B.3})$$

Define the following

$$I_0 \triangleq \frac{|I_{01}| + |I_{02}|}{2} , \quad I_0 > 0$$

and

$$I' \triangleq \frac{|I_{01}| - |I_{02}|}{2I_0} , \quad -1 < I' < 1 . \quad (\text{B.4})$$

The average velocity of the two drifting charge fields is given by

$$u_o \triangleq \frac{u_{o1} + u_{o2}}{2}, \quad u_o > 0 \quad (\text{B.5})$$

and a relative velocity parameter is then defined as

$$b \triangleq \frac{u_{o1} - u_{o2}}{2u_o} = \frac{1 - \frac{u_{o2}}{u_o}}{1 + \frac{u_{o2}}{u_o}}, \quad |b| \geq 1 \quad (\text{B.6})$$

Thus the individual initial average velocities are given by

$$u_{o1} = u_o(1 + b)$$

and

$$u_{o2} = u_o(1 - b) \quad (\text{B.7})$$

Since a one-dimensional system is assumed any possible potential depression across the charge field is ignored.

2.2 R-f Circuit Equation. Following the pattern of previous one-dimensional analyses the presence of an r-f propagating circuit is accounted for by the following one-dimensional equivalent-circuit transmission-line equation.

$$\frac{\partial^2 \bar{V}(z,t)}{\partial t^2} - v_o^2 \frac{\partial^2 \bar{V}(z,t)}{\partial z^2} = \pm v_o Z_o \frac{\partial^2 \rho(z,t)}{\partial t^2}, \quad (\text{B.8})$$

where possible circuit loss has been neglected and the plus sign on the right of Eq. B.8 assumes a forward-space harmonic interaction and the minus sign a backward-wave interaction. The r-f voltage function is again written as the product of slowly varying functions of the type

$$V(z,t) = V(y,\phi) \triangleq \text{Re} \left[ \frac{Z_o I_o}{C} A(y) e^{-j\phi} \right], \quad (\text{B.9})$$

where

$$C \triangleq \frac{\eta_o I_o Z_o}{2u_o^2}$$

and

$$D^2 \triangleq \left( \frac{v_o}{u_o} \right)^2 C^2 .$$

It is convenient to introduce another velocity parameter which indicates the difference in the average stream velocity  $u_o$  and the circuit velocity  $v_o$ . This parameter is defined by

$$D^2 = \frac{C^2}{(1 + Cp)^2} ,$$

where

$$\frac{u_o}{v_o} = 1 + Cp .$$

The normalized axial distance and particle phase-position variables are defined following previous work as

$$y \triangleq \frac{C\omega}{u_o} z = 2\pi CN_s \quad (B.10)$$

and

$$\phi(z,t) \triangleq \omega \left( \frac{z}{u_o} - t \right) - \theta(y) , \quad (B.11)$$

where  $N_s = z/\lambda_s = zf/u_o$ . The definitions are completed by introducing the particle velocities as

$$\left. \frac{dz}{dt} \right|_1 = v_1 \triangleq u_{o1} \left[ 1 + 2Cu_1(y, \phi_o) \right]$$

and

$$\left. \frac{dz}{dt} \right|_2 = v_2 \triangleq u_{o2} \left[ 1 + 2Cu_2(y, \phi_o) \right] . \quad (B.12)$$

The values of  $A(y)$ ,  $\phi$ ,  $u_1$  and  $u_2$  that a particular charged particle experiences at a given displacement plane depend upon the initial phase characterizing its entry into one of the charge fields. The initial phases are defined as  $\phi_{01,j}$  and  $\phi_{02,j}$  for the particles in the first and second charge fields, respectively. The resulting two inhomogeneous circuit equations are

$$A(y) + D^2 \frac{d^2 A(y)}{dy^2} - D^2 \left( \frac{1}{C} - \frac{d\theta(y)}{dy} \right)^2 A(y) \\ = \frac{\epsilon_1 D(1+I')}{\pi(1+b)} \int_0^{2\pi} \frac{\cos \phi' d\phi'_{01}}{1 + 2Cu'_1} + \frac{\epsilon_2 D(1-I')}{\pi(1-b)} \int_0^{2\pi} \frac{\cos \phi'' d\phi''_{02}}{1 + 2Cu''_2} \quad (B.13)$$

and

$$D \frac{d^2 \theta(y)}{dy^2} A(y) - 2D \left( \frac{1}{C} - \frac{d\theta(y)}{dy} \right) \frac{dA(y)}{dy} \\ = \frac{\epsilon_1 (1+I')}{\pi(1+b)} \int_0^{2\pi} \frac{\sin \phi' d\phi'_{01}}{1 + 2Cu'_1} + \frac{\epsilon_2 (1-I')}{\pi(1-b)} \int_0^{2\pi} \frac{\sin \phi'' d\phi''_{02}}{1 + 2Cu''_2} \quad (B.14)$$

#### Dependent Variable Equations

After taking the appropriate differentials of the dependent phase variables the following relations between  $\phi$  and  $u$  are evolved:

$$\frac{\partial \phi(y, \phi_{01})}{\partial y} + \frac{d\theta(y)}{dy} = \frac{1}{C} \left[ 1 - \frac{1}{(1+b) [1 + 2Cu'_1(y, \phi_{01})]} \right] \quad (B.15)$$

and

$$\frac{\partial \phi(y, \phi_{02})}{\partial y} + \frac{d\theta(y)}{dy} = \frac{1}{C} \left[ 1 - \frac{1}{(1-b) [1 + 2Cu''_2(y, \phi_{02})]} \right] \quad (B.16)$$

Each of the above equations is "m" in number when m individual charge groups are considered.

### Lorentz Force Equations

We have assumed that all microscopic collision effects may be neglected and since all wave and particle velocities are small compared to the velocity of light the particle self-magnetic field is negligible and thus for confined one-dimensional flow the Lorentz force equations become

$$\frac{dv_1}{dt} = \eta_1 \left[ -\frac{\partial V_c}{\partial z} + E_{scz-1} \right] \quad (B.17)$$

and

$$\frac{dv_2}{dt} = \eta_2 \left[ -\frac{\partial V_c}{\partial z} + E_{scz-2} \right] , \quad (B.18)$$

where  $E_{scz-1}$  and  $E_{scz-2}$  represent the total space-charge fields acting upon each particle individually. The effects of collisions may be introduced by adding an additional electric field term appropriate to the collision model.

The space-charge-field expressions are calculated from electrostatics for an axially symmetric system considering the charge fields to be concentric rings of charge. It is convenient to define a mean radius for the outer charge field. Thus

$$b'_0 \triangleq \frac{b'_2 + b'_3}{2} . \quad (B.19)$$

The total coulomb field is the sum of that produced by each charge field acting separately. Poisson's equation is written as

$$\nabla^2 V(r,z) = -\frac{\rho}{\epsilon_0 \alpha} , \quad (B.20)$$

where  $\alpha \triangleq$  cross-section area of the particular charge field. The complementary Laplace equation must also be satisfied for  $b'_3 < b < a$  and the

field matching at the various boundaries defines the eigenvalue problem, the eigenvalues being the space-charge-wave propagation constants designated as  $\beta_1$  and  $\beta_2$ , respectively.

In the above Lagrangian description of the system interaction the charge densities,  $\rho_1$  and  $\rho_2$ , are written in terms of the entering charge densities, respectively, after invoking the conservation of charge. The following expressions evolve:

$$\rho_1 = \frac{I_{o1}}{u_{o1}} \left| \frac{\partial \phi_{o1}}{\partial \phi_1} \right| \frac{1}{[1 + 2Cu_1(y, \phi_{o1})]}$$

and

$$\rho_2 = \frac{I_{o2}}{u_{o2}} \left| \frac{\partial \phi_{o2}}{\partial \phi_2} \right| \frac{1}{[1 + 2Cu_2(y, \phi_{o2})]} \quad (B.21)$$

The one-dimensional space-charge-field weighting functions are derived following the procedure outlined in Reference 101.

$${}_{11}F(\phi_1 - \phi'_1) \triangleq \sum_{n=1}^{\infty} \frac{\sin \left[ n(\phi_1 - \phi'_1) \left( \frac{1}{1+b} \right) \right]_{11} R_n^2}{2\pi n}, \quad (B.22)$$

$${}_{21}F(\phi_1 - \phi''_2) \triangleq \sum_{n=1}^{\infty} \frac{\sin \left[ n(\phi_1 - \phi''_2) \left( \frac{1}{1-b} \right) \right]_{21} R_n^2}{2\pi n}, \quad (B.23)$$

$${}_{12}F(\phi_2 - \phi'_1) \triangleq \sum_{n=1}^{\infty} \frac{\sin \left[ n(\phi_2 - \phi'_1) \left( \frac{1}{1+b} \right) \right]_{12} R_n^2}{2\pi n} \quad (B.24)$$

and

$${}_{22}F(\phi_2 - \phi''_2) \triangleq \sum_{n=1}^{\infty} \frac{\sin \left[ n(\phi_2 - \phi''_2) \left( \frac{1}{1-b} \right) \right]_{22} R_n^2}{2\pi n}, \quad (B.25)$$

where the symbols  $\phi''_2$  and  $\phi'_1$  mean "taking the phase of the particles in the second (first) beam". Now define the appropriate radian plasma frequencies as

$$\omega_{p1}^2 \triangleq \frac{\eta_1 I_{o1}}{\epsilon_o \alpha_1 u_{o1}}$$

and

$$\omega_{p2}^2 \triangleq \frac{\eta_2 I_{o2}}{\epsilon_o \alpha_2 u_{o2}} \quad (B.26)$$

The complete forms for the electric fields associated with the charge fields are now written as

$$\begin{aligned} E_{scz-1} = & \frac{2\epsilon_1 u_{o1}}{(1+\eta')(1+b)} \left( \frac{\omega_{p1}^2}{\eta_o \omega} \right) \int_0^{2\pi} \frac{F(\phi_1 - \phi') d\phi'_1}{[1+2Cu_1(y, \phi'_{o1})]} \\ & + \frac{2\epsilon_2 u_{o1}}{(1-\eta')(1-b)} \left( \frac{\omega_{p2}^2}{\eta_o \omega} \right) \int_0^{2\pi} \frac{F(\phi_1 - \phi'') d\phi''_2}{[1+2Cu_2(y, \phi''_{o2})]} \quad (B.27) \end{aligned}$$

and

$$\begin{aligned} E_{scz-2} = & \frac{2\epsilon_1 u_{o2}}{(1+\eta')(1+b)} \left( \frac{\omega_{p1}^2}{\eta_o \omega} \right) \int_0^{2\pi} \frac{F(\phi_2 - \phi') d\phi'_1}{[1+2Cu_1(y, \phi'_{o1})]} \\ & + \frac{2\epsilon_2 u_{o2}}{(1-\eta')(1-b)} \left( \frac{\omega_{p2}^2}{\eta_o \omega} \right) \int_0^{2\pi} \frac{F(\phi_2 - \phi'') d\phi''_2}{[1+2Cu_2(y, \phi''_{o2})]} \quad (B.28) \end{aligned}$$

Substitution of the above expressions for the fields and the plasma frequencies into Eqs. B.17 and B.18 yields the final form of the force equations.

$$\begin{aligned} [1+2Cu_1(y, \phi_{o1})] \frac{\partial u_1(y, \phi_{o1})}{\partial y} = & - \frac{\epsilon_1 C(1+\eta')}{(1+b)^2} \left[ \frac{dA(y)}{dy} \cos \phi_1(y, \phi_{o1}) \right. \\ & - A(y) \left( \frac{1}{C} - \frac{d\theta(y)}{dy} \right) \sin \phi_1(y, \phi_{o1}) \left. \right] + \frac{1}{(1+b)^2} \left( \frac{\omega_{p1}}{\omega C} \right)^2 \int_0^{2\pi} \frac{F(\phi_1 - \phi') d\phi'_1}{[1+2Cu_1(y, \phi'_{o1})]} \\ & + \frac{\epsilon_1 \epsilon_2 (1+\eta')}{(1+b)^2 (1-\eta')} \left( \frac{\omega_{p2}}{\omega C} \right)^2 \int_0^{2\pi} \frac{F(\phi_1 - \phi'') d\phi''_2}{[1+2Cu_2(y, \phi''_{o2})]} \quad (B.29) \end{aligned}$$

and

$$\begin{aligned}
 [1+2Cu_2(y, \phi_{o2})] \frac{\partial u_2(y, \phi_{o2})}{\partial y} &= - \frac{\epsilon_2 C(1-\eta')}{(1-b)^2} \left[ \frac{dA(y)}{dy} \cos \phi_2(y, \phi_{o2}) \right. \\
 - A(y) \left( \frac{1}{C} - \frac{d\theta(y)}{dy} \right) \sin \phi_2(y, \phi_{o2}) &\left. \right] + \frac{1}{(1-b)^2} \left( \frac{\omega_{p2}}{\omega C} \right)^2 \int_0^{2\pi} \frac{F(\phi_2 - \phi'') d\phi''_{o2}}{[1+2Cu_2(y, \phi''_{o2})]} \\
 + \frac{\epsilon_1 \epsilon_2 (1-\eta')}{(1-b)^2 (1+\eta')} \left( \frac{\omega_{p1}}{\omega C} \right)^2 &\int_0^{2\pi} \frac{F(\phi_2 - \phi'_1) d\phi'_{o1}}{[1+2Cu_1(y, \phi'_{o1})]} \quad . \quad (B.30)
 \end{aligned}$$

The above system of equations (B.13, B.14, B.15, B.16, B.29 and B.30) are the nonlinear equations for the beam-plasma or double-beam system including the presence of r-f circuit fields. The radian plasma frequency reduction factors which determine the effective plasma frequency are shown in Fig. B.2.

### 3. Double-Beam Interaction

In the case of two electron beams interacting, i.e.,  $\epsilon_1 = \epsilon_2 = -1$  we would expect to obtain results much like the ones for the klystron. If  $b = 0$ , i.e., no velocity slip between beams, then the results are identical to those for the klystron. If  $b \geq 0$  then the current characteristics of the two beams are displaced with respect to one another as a result of the phasing of currents in the two beams. The harmonics are of lower amplitude and reach a maximum in a shorter distance from the velocity modulation cavity. The maximum value of  $i_1/I_{ok}$  ( $k$  denotes the particular beam) is approximately 1.16 which corresponds to the ballistic theory value of

$$\begin{aligned}
 \frac{i_1}{I_o} &= 2J_1 \Big|_{\max.} \\
 &= 2(0.58) = 1.16 \quad .
 \end{aligned}$$



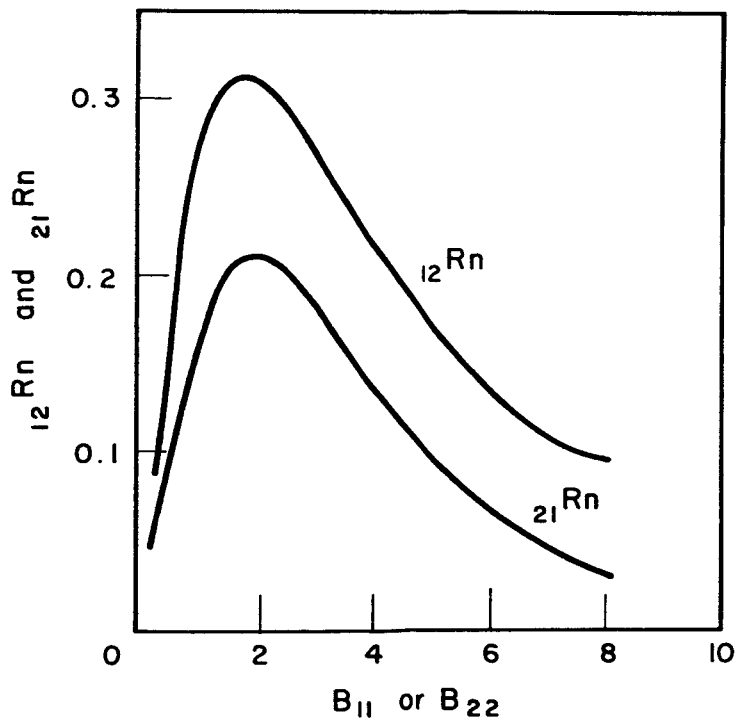
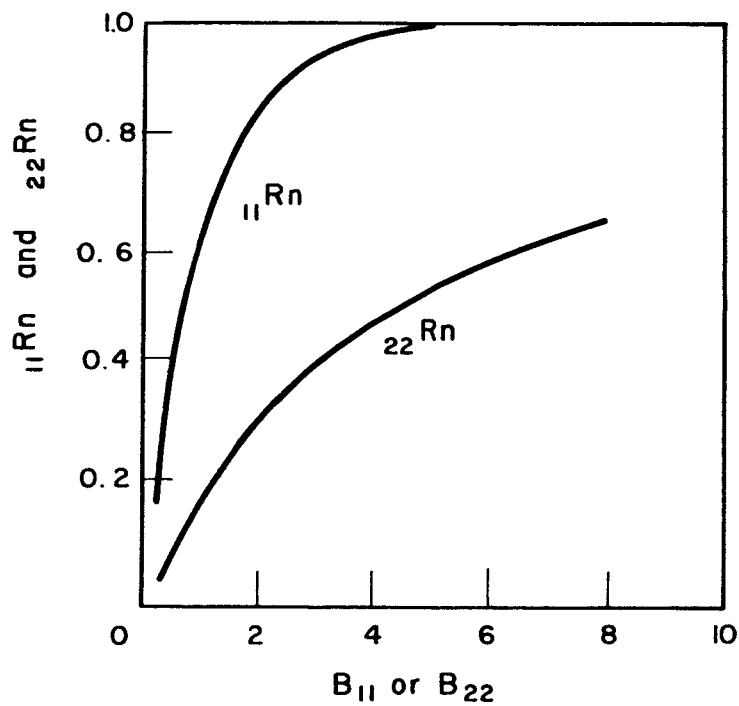

FIG. B.2 PLASMA FREQUENCY REDUCTION FACTORS FOR A DOUBLE CHARGE FIELD CONFIGURATION.

The distance scale is again plotted in terms of the bunching parameter  $X = \pi \alpha N_g$  so that when  $X \approx 1.84$  the initial velocity modulation has been converted to a current modulation, i.e., in  $\lambda_q/4$  as predicted by the ballistic theory.

In beam and plasma problems a characteristic length related to both the density and temperature of the charge field is the Debye length  $\lambda_D$ . The normalized length  $y = X$  is written in terms of the Debye length as

$$y = X = \frac{\pi \alpha}{\sqrt{2} \omega_p} \left( \frac{z}{\lambda_D} \right) .$$

The effect of space charge, i.e., finite  $\omega_p/\omega$ , on the fundamental current amplitude is depicted in Fig. B.3 for zero velocity slip. The principal effect is to increase the fundamental current amplitude above the 1.16 value in one beam at the expense of the other beam. There is also a slight shifting of the position at which the current is a maximum, again the average is approximately that for the  $b = 0$  case. Similar shifts appear when there is a velocity slip between the beams.

#### 4. Beam-Plasma Interaction

The characteristics of the beam-plasma interaction are quite similar to those of the double-beam case, the fundamental current amplitudes being in the vicinity of 1.16. The same equations apply to this problem and the difference in charge signs is accounted for by the specification of  $\epsilon_1$  and  $\epsilon_2$ . In this section  $\epsilon_1 = -1$  and  $\epsilon_2 = 1$ . A summary of the current information on the beam-plasma interaction is shown in Fig. B.4. These data indicate that the fundamental current amplitude in the electron beam can rise well above the 1.16 value while the corresponding value for the ion beam is approximately 1.05. The exact values are quite dependent upon  $b$ ,  $I'$  and  $\eta'$ .

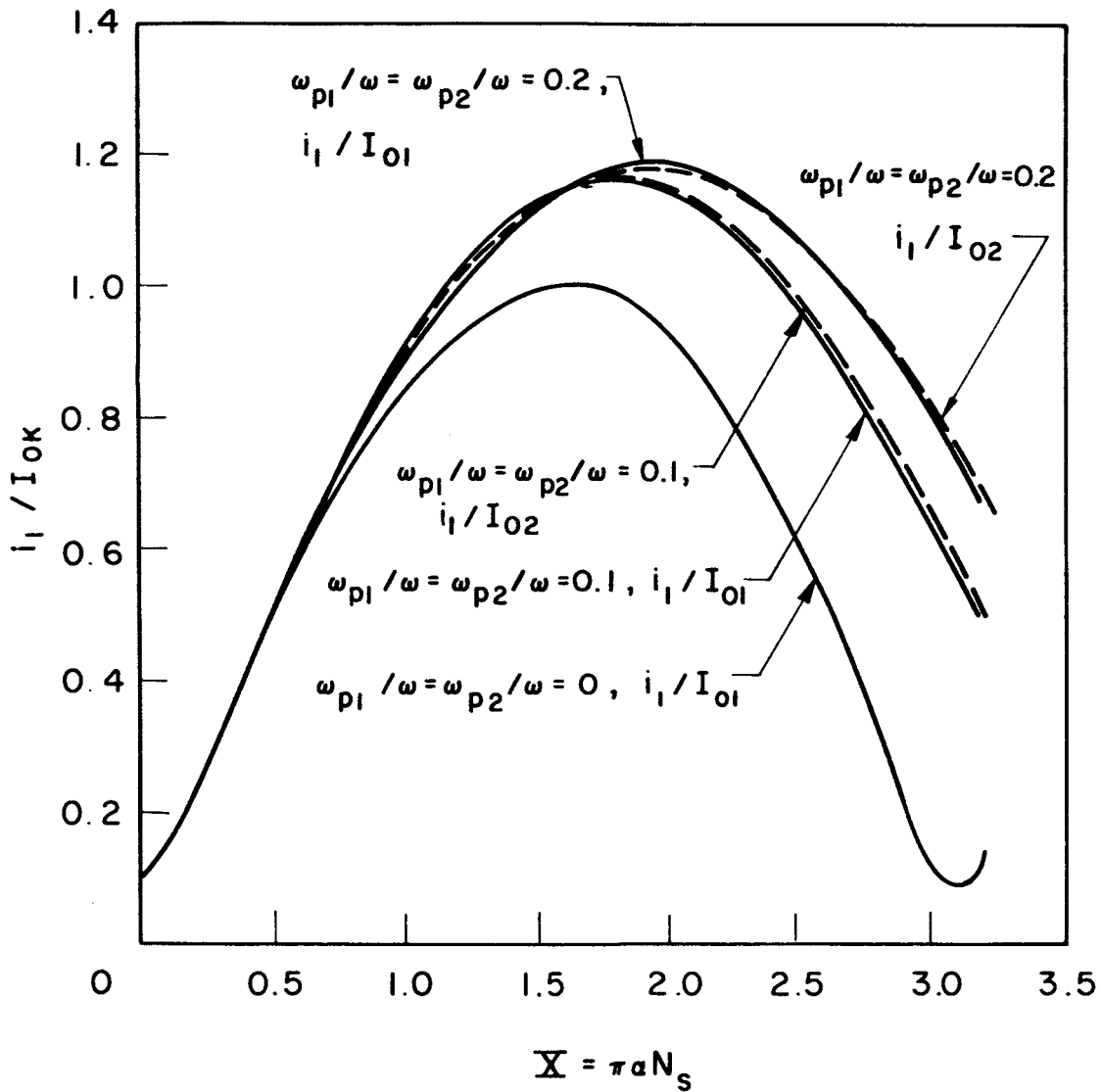

FIG. B.3 DOUBLE-BEAM INTERACTION. EFFECT OF SPACE CHARGE ON FUNDAMENTAL CURRENT AMPLITUDE. ( $\epsilon_1 = \epsilon_2 = -1$ ,  $\alpha = 0.2$ ,  $I' = \eta' = 0$ ,  $b = 0$ )

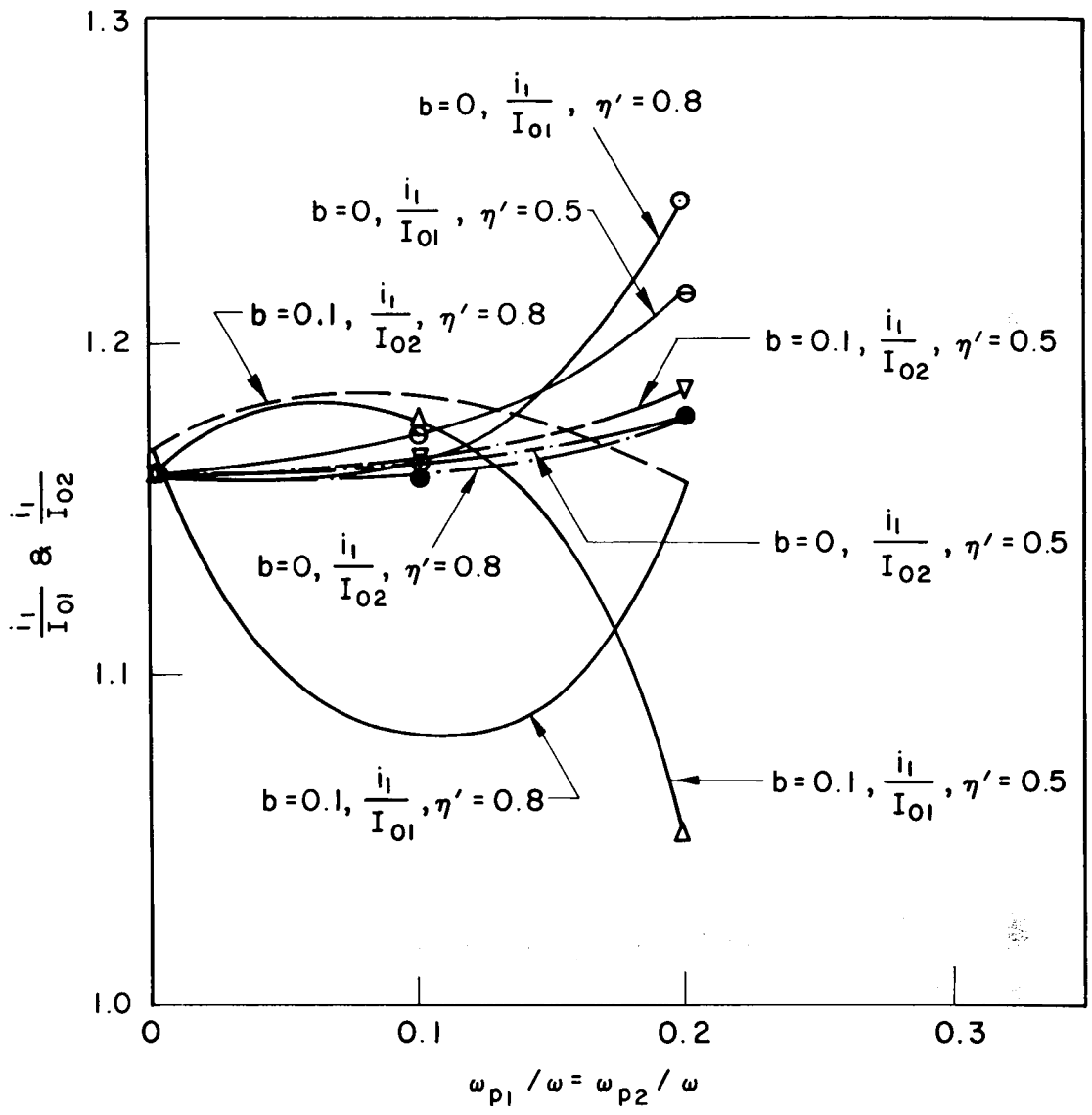

FIG. B.4 BEAM-PLASMA INTERACTION. FUNDAMENTAL CURRENT AMPLITUDE VS.  $\frac{\omega_p}{\omega}$ ,  $b$  AND  $\eta'$ . ( $\epsilon_1 = -1, \epsilon_2 = +1, \alpha = 0.2, I' = 0$ )

## LIST OF REFERENCES

1. Pawsey, J. L., McCready, L. L. and Gardner, F. F., "Ionospheric Thermal Radiation at Radio Frequencies", Jour. Atm. and Terres. Phys., vol. 1, pp. 261-277; May, 1951.
2. Gardner, F. F., "Ionospheric Thermal Radiation at Radio Frequencies II. Further Observation", Jour. Atm. and Terres. Phys., vol. 5, pp. 298-315; November, 1954.
3. Dowden, R. L., "Ionospheric Thermal Radiation at Radio Frequencies in the Auroral Zone", Jour. Atm. and Terres. Phys., vol. 18, pp. 8-19; April, 1960.
4. Little, C. G., Lorfald, G. M. and Parthasarathy, R., "Some Observations of 2.89 Mc/s Equivalent Antenna Temperatures at the Auroral Zone", Jour. Atm. and Terres. Phys., vol. 23, pp. 275-286; December, 1961.
5. Rytov, S. M., "Theory of Electrical Fluctuation and Thermal Radiation", Translation by Electronic Research Directorate, U. S. Air Force, Bedford, Mass.; 1959.
6. Haus, H. A., "Thermal Noise in Dissipative Media", Jour. Appl Phys., vol. 32, pp. 493-499; March, 1961.
7. Vanwormhoudt, M. and Haus, H. A., "Thermal Noise in Linear, Lossy, Electromagnetic Media", Jour. Appl. Phys., vol. 33, pp. 2572-2577; August, 1962.
8. Callen, H. B. and Green, P. F., "On a Theorem of Irreversible Thermodynamics", Phys. Rev., vol. 86, pp. 702-710; June, 1952.
9. Callen, H. B. and Welton, T. A., "Irreversibility and Generalized Noise", Phys. Rev., vol. 83, pp. 34-40; July, 1951.
10. Wax, N., Selected Papers on Noise and Stochastic Process, Dover Publication, New York, N. Y.; 1954.

11. Allis, W. P., "Motion of Ions and Electrons", Handbuck der Physik, Springer-Verlag, Berlin, vol. 21; 1957.
12. Molmud, P., "Langevin Equation and the A-c Conductivity of Non-Maxwellian Plasma", Phys. Rev., vol. 114, pp. 29-32; April, 1959.
13. Caldirola, P. and DeBarbieri, O., "On Some Nonlinear Phenomena in the Ionospheric Plasma", Conference on Nonlinear Process in Ionosphere, NBS Tech. Rept. No. 211, vol. 1, pp. 27-83; December, 1963.
14. Rao, K. V., Verdeyen, J. T. and Goldstein, L., "Interaction of Microwaves in Gaseous Plasma Immersed in Magnetic Fields", Proc. IRE, vol. 49, pp. 1877-1889; December, 1961.
15. Nyquist, H., "Thermal Agitation of Electric Charge in Conductors", Phys. Rev., vol. 32, pp. 110-113; July, 1928.
16. Freeman, J. J., Principle of Noise, John Wiley and Son Inc., New York, N. Y.; 1958.
17. Wait, J. R., "On the Theory of Schuman Resonance in the Earth-Ionospheric Cavity", Canadian Jour. Phys., vol. 42, pp. 575-582; April, 1964.
18. Gallet, R. M. and Helliwell, R. A., "Origin of Very-Low-Frequency Emissions", Jour. Res. NBS, vol. 63D, pp. 21-27; July-August, 1959.
19. Dowden, R. L., "Theory of Generation of Exospheric Very-Low-Frequency Noise (Hiss)", Jour. Geophys. Res., vol. 67, pp. 2223-2230; June, 1962.
20. Bell, T. F. and Buneman, O., "Plasma Instability in the Whistler Mode Caused by a Gyrationg Electron Streams", Phys. Rev., vol. A133, pp. 1300-1302; March, 1964.
21. Scarf, E. L., "Landau Damping and the Attenuation of Whistlers", Phys. Fluid, vol. 5, pp. 6-13; January, 1962.

22. Pierce, J. R., Traveling Wave Tubes, D. Van Nostrand Co. Inc., New York, N. Y.; 1950.
23. Gallet, R. M., "The Very-Low-Frequency Emissions Generated in the Earth's Exosphere", Proc. IRE, vol. 47, pp. 211-231; February, 1959.
24. Helliwell, R. A. and Morgan, M. G., "Atmospheric Whistlers", Proc. IRE, vol. 47, pp. 200-208; February, 1959.
25. Smith, R., "The Use of Noise Whistler in the Study of the Outer Ionosphere", Stanford Electronic Labs., Tech. Rept. 6, Contract AF 18(603)-126; July, 1960.
26. Brice, N., "An Explanation of Triggered Very-Low-Frequency Emissions", Jour. Geophys. Res. Letter, vol. 68, pp. 4626-4628; August, 1963.
27. Neufeld, J. and Wright, H., "Instabilities in a Plasma-Beam System Immersed in a Magnetic Field", Phys. Rev., vol. 129, pp. 1489-1507; February, 1963.
28. Miller, R. I., "Instabilities in the Whistler Mode Cause by Velocity Anisotropics in Fast-Particle Fluxes", Paper presented at 1964 Fall URSI Meeting, (Abstract only); October 12-14, 1964.
29. Tidman, D. A. and Jaggi, R. K., "Landau Damping of Transverse Waves in the Exosphere by Fast-Particle Flux", Jour. Geophys. Res., vol. 67, pp. 2215-2222; June, 1962.
30. Rand, S., "Absorption of Radiation by the Ionosphere", Phys. Fluid, vol. 5, pp. 1237-1247; October, 1962.
31. Guthart, H., "Anisotropic Electron Velocity Distribution for Cyclotron Absorption of Whistlers and VLF Emissions", Paper presented at 1964 Fall URSI Meeting, (Abstract only); October 12-14, 1964.
32. Platzman, P. M. and Buchsbaum, S. J., "Effect of Collisions on the Landau Damping of Plasma Oscillations", Phys. Fluid, vol. 4, pp. 1288-1292; October, 1961.

33. Lepechinsky, D. and Rolland, P., "On Plasma Instabilities and Their Probable Role in Ionospheric Phenomena", Jour. Atm. and Terres. Phys., vol. 26, pp. 31-40; January, 1964.
34. Sturrock, P., "Amplifying and Evanescent Waves, Convective and Non-Convective Instabilities", Plasma Dynamics (ed. Drummond, J.), McGraw-Hill Book Co., New York, N. Y., Chap. 4; 1961.
35. Pierce, J. R., "Possible Fluctuations in Electron Streams due to Ions", Jour. Appl. Phys., vol. 19, pp. 231-236; March, 1948.
36. Pierce, J. R., "Double Stream Amplifier", Proc. IRE, vol. 37, pp. 980-985; September, 1949.
37. Haeff, A. V., "The Electron-Wave Tube--A Novel Method of Generation and Amplification of Microwave Energy", Proc. IRE, vol. 37, pp. 4-10; January, 1949.
38. Haeff, A. V., "On the Origin of Solar Radio Noise", Phys. Rev. vol. 75, pp. 1546-1551; May, 1949.
39. Feinstein, J. and Sen, H. K., "Radio Wave Generation by Multistream Charge Interaction", Phys. Rev., vol. 83, pp. 405-412; July, 1951.
40. Sen, H. K., "Nonlinear Theory of Space-Charged Wave in Moving, Interacting Electron Beams with Application to Solar Radio Noise", Phys. Rev., vol. 97, pp. 849-855; February, 1955.
41. Malville, J. M., "Characteristics of Type III Radio Bursts", Astrophys. Jour., vol. 136, pp. 266-275; July, 1962.
42. Barthel, J. R. and Sowle, D. H., "A Mechanism of Injection of Solar Plasma into the Magnetosphere", Planet Space Sci., vol. 12, pp. 209-218; March, 1964.
43. Feinstein, J., "The Conversion of Space-Charge-Wave Energy into Electromagnetic Radiation", Proc. Symp. of Electronic Waveguide, pp. 345-352, Polytech. Inst. of Brooklyn, Brooklyn, N. Y.; 1958.



44. Ginzburg, V. L. and Zhelezniakov, V. V., "On the Possible Mechanisms of Sporadic Solar Radio Emission (Radiation in an Isotropic Plasma)", Soviet Astron., vol. 2, pp. 653-668; September-October, 1958.
45. Wild, J. P., Murray, J. D. and Rowe, W. C., "Evidence of Harmonics in the Spectrum of a Solar Radio Outburst", Nature, vol. 172, pp. 533-534; September, 1953.
46. Pierce, J. R. and Louisell, W. H., "Power Flow in Electron Beam Devices", Proc. IRE, vol. 43, pp. 425-426; April, 1955.
47. Haus, H. and Bobroff, D., "Small Signal Power Theorem for Electron Beams", Jour. Appl. Phys., vol. 28, pp. 694-703; June, 1957.
48. Pierce, J. R., "Coupling of Modes of Propagation", Jour. Appl. Phys., vol. 25, pp. 179-183; February, 1954.
49. Pierce, J. R., "The Wave Picture of Microwave Tubes", BSTJ, vol. 33, pp. 1343-1372; November, 1954.
50. Gould, R. W., "A Coupled Mode Description of the Backward-Wave Oscillation and the Kompfner Dip Condition", Trans. PGED-IRE, vol. 2, No. 4, pp. 37-42; October, 1955.
51. Penrose, O., "Electrostatic Instabilities of a Uniform Non-Maxwellian Plasma", Phys. Fluid, vol. 3, pp. 258-265; March-April, 1960.
52. Ichimaru, S., "Wave Properties of a Plasma with a Doubly Humped Velocity Distribution", Phys. Fluid, vol. 5, pp. 1264-1271; October, 1962.
53. Jackson, E. A., "Drift Instabilities in Maxwellian Plasma", Phys. Fluid, vol. 3, pp. 786-792; September, 1960.
54. Frieman, E. and Pytee, A., "Electrostatic Instabilities in Slightly Inhomogeneous Plasma", Phys. Fluid, vol. 4, pp. 1026-1031; August, 1961.

55. Krall, N. A. and Rosenbluth, M. N., "Stability of a Slightly Inhomogeneous Plasma", Phys. Fluid, vol. 4, pp. 163-172; February, 1961.
56. Neufeld, J. and Doyle, P. H., "Electromagnetic Interaction of a Beam of Charged Particles with Plasma", Phys. Rev., vol. 121, pp. 654-658; February 1961.
57. Neufeld, J., "Electromagnetic Properties of a Plasma-Beam System", Phys. Rev., vol. 127, pp. 346-359; July, 1962.
58. Sturrock, P. A., "Excitation of Plasma Oscillation", Phys. Rev., vol. 117, pp. 1426-1429; March, 1960.
59. Boyd, G. D., Gould, R. W. and Field, L. M., "Interaction of a Modulated Electron Beam with a Plasma", Proc. IRE, vol. 49, pp. 1906-1916; December, 1961.
60. Crawford, F. W. and Kino, G. S., "Oscillation and Noise in Low-Pressure D-c Discharges", Proc. IRE, vol. 49, pp. 1767-1788; December, 1961.
61. Watson, K. M., Bludman, S. A. and Rosenbluth, M. N., "Statistical Mechanics of Relativistic Streams", Phys. Fluid, vol. 3, pp. 741-757; May, 1960.
62. Frieman, E. A., et al., "Two-Stream Instability in Finite Beams", Phys. Fluid, vol. 5, pp. 196-209; February, 1962.
63. Burt, P. and Harris, E. G., "Unstable Cyclotron Oscillation in a Cylindrical Plasma Shell", Phys. Fluid, vol. 4, pp. 1412-1416; November, 1961.
64. Neufeld, J. and Wright, H., "Instabilities in a Plasma-Beam System Immersed in Magnetic Field", Phys. Rev., vol. 129, pp. 1489-1507; February, 1963.

65. Farley, D. T., Jr., "A Plasma Instability Resulting in Field-Aligned Irregularities in the Ionosphere", Jour. Geophys. Res., vol. 68, pp. 6083-6097; November, 1963.
66. Neufeld, J., "Interaction of a Stationary Plasma with an Electron Beam", Phys. Fluid, vol. 7, pp. 306-310; February, 1964.
67. Unz, H., "On the Origin of Very-Low-Frequency Emission", Jour. Atm. and Terres. Phys., vol. 24, pp. 685-689; August, 1962.
68. Wild, J. P., Sheridan, K. V. and Trent, G. H., "The Transverse Motions of the Sources of Solar Radio Bursts", Paris Symp. on Radio Astronomy, Stanford University Press, Stanford, Calif., pp. 176-185; 1959.
69. Wild, J. P., Sheridan, K. V. and Neylan, A. A., "An Investigation of the Speed of the Solar Disturbances Responsible for Type III Radio Bursts", Australian Jour. Phys., vol. 12, pp. 369-398; December, 1959.
70. Ginzburg, V. L. and Zhelezniakov, V. V., "Noncoherent Mechanisms of Sporadic Solar Radio Emission in the Case of Magnetoactive Corona Plasma", Soviet Astron., vol. 5, pp. 1-13; July-August, 1961.
71. Cohen, M. H., "Radiation in a Plasma I Cerenkov effect", Phys. Rev., vol. 123, pp. 711-721; August, 1961.
72. Cohen, M. H., "Scattering and Conversion Cross Sections in Inhomogeneous Plasma", Jour. Geophys. Res., vol. 67, pp. 2729-2740; July, 1962.
73. Smerd, S. F., Wild, J. P. and Sheridan, K. V., "On the Relative Position and Origin of Harmonics in the Spectra of Solar Radio Bursts of Spectral Type II and III", Australian Jour. Phys., vol. 15, pp. 180-193; June, 1962.
74. Roberts, J. A., "Solar Radio Bursts of Spectral Type II", Australian Jour. Phys., vol. 12, pp. 327-356; December, 1959.

75. Maxwell, A. and Thompson, A. R., "Spectral Observation of Solar Radio Bursts II, Slow Drift Bursts and Coronal Streams", Astrophys. Jour., vol. 135, pp. 158-150; January, 1962.
76. Wild, J. P., Murray, J. D. and Rowe, W. C., "Harmonics in the Spectral of Solar Radio Disturbances", Australian Jour. Phys., vol. 7, pp. 439-459; September, 1954.
77. Westfold, K. C., "The Wave Equations for Electromagnetic Radiation in an Ionized Medium in a Magnetic Field", Australian Jour. Sci. Res., vol. A2, pp. 169-183; June, 1949.
78. Gross, E. P., "Plasma Oscillations in a Static Magnetic Field", Phys. Rev., vol. 82; pp. 232-242; April, 1951.
79. Sen, H. K., "Solar 'Enhanced Radiation' and Plasma Oscillations", Phys. Rev., vol. 88, pp. 816-822; November, 1952.
80. Bayet, M., "Propriétés Electromagnétiques Des Plasmas Soumis A un Champ Magnétique", Jour. Phys. Radium, vol. 15, pp. 258-263; April, 1954.
81. Akhiezer, A. I. and Sitenko, A. G., "Penetration of Charged Particles Through an Electron Plasma", Jour. Exp. Theo. Phys., vol. 23, pp. 161-168; 1952 (Translated by Atomic Energy Research Establishment, Great Britain, Lib./trans. 759; June, 1956.)
82. Pines, D. and Bohm, D., "A Collective Description of Electron Interactions; II. Collective vs. Individual Particle Aspects of the Interactions", Phys. Rev., vol. 85, pp. 330-353; January, 1952.
83. Smerd, S. F., "Non-linear Plasma Oscillation and Bursts of Solar Radio Emission", Nature (Letter), vol. 175, p. 297; February, 1955.

84. Ginzburg, V. L. and Zhelezniakov, V. V., "On the Propagation of Electromagnetic Waves in the Solar Corona, Taking into Account the Influence of the Magnetic Field", Soviet Astron., vol. 3, pp. 235-246; March-April, 1959.
85. Cohen, M. H., "Radio Bursts from the Sun", Proc. Symp. Wave Interaction and Dynamic Non-Linear Phenomena in Plasma, Penn. State Univ. Press, pp. 118-120, Sept. 1963.
86. Sturrock, P. A., "Spectral Characteristics of Type II Solar Radio Bursts", Nature, vol. 192, p. 58; October, 1961.
87. Fainberg, I. B., "The Interaction of Charged Particle Beam with Plasma", Jour. Nucl. Energy, Part C, (Plasma Physics), vol. 4, pp. 203-220; June, 1962.
88. Sturrock, P. A., "Non-Linear Effects in Electron Plasma", Jour. Nucl. Energy, Part C, (Plasma Physics), vol. 2, pp. 158-163; January, 1961.
89. Abele, M., "Radiation in a Plasma from a Uniformly Moving Distribution of Electron Charge", Proc. Symp. on Electromagnetic and Fluid Dynamics of Gaseous Plasma, Polytech. Press, Poly. Inst. of Brooklyn, Brooklyn, N. Y., p. 153; 1961.
90. Tuan, H. S. and Seshadri, S. R., "Radiation from a Line Source in a Uniaxially Anisotropic Plasma", Cruft Lab., Harvard Univ., Tech. Rept. 375; 1962.
91. Johnson, P. S., "Cerenkov Radiation Spectra for a Cold Magnetoactive Plasma", Phys. Fluid, (Res. Notes), vol. 5, pp. 118-120; January, 1962.
92. Ford, G. W., "Electromagnetic Radiation from a Source in a Plasma", Am. Phys., vol. 16, pp. 185-200; November, 1961.
93. Field, G. B., "Radiation by Plasma Oscillation", Astrophys. Jour., vol. 124, pp. 555-570; November, 1956.

94. Tidman, D. A. and Boyd, J. M., "Radiation by Plasma Oscillation Incident on a Density Discontinuity", Phys. Fluid, vol. 5, pp. 213-218; February, 1962.
95. Gould, R. W., "Plasma Oscillations and Radio Noise from the Disturbed Sun", ASTIA AD-82282; November, 1955.
96. Tidman, D. A., "Radio Emission by Plasma Oscillation in Nonuniform Plasma", Phys. Rev., vol. 117, pp. 366-374; January, 1960.
97. Tidman, D. A. and Weiss, G. H., "Radiation by Plasma Oscillations in Nonuniform Plasmas", Phys. Fluid, vol. 4, pp. 703-710; June, 1961.
98. Tidman, D. A. and Weiss, G. H., "Radiation of a Large-Amplitude Plasma Oscillation", Phys. Fluid, vol. 4, pp. 866-868; July, 1961.
99. Shklovsky, I. S., "On the Radiation of Radio-Waves by the Galaxy and by the Upper Layers of the Solar Atmosphere", Astron. Zhur., (Astrophys. Jour. of the Soviet Union), vol. 23, pp. 333-347; June, 1946.
100. Boyd, T. J. M., "Emission of Radio Noise by Plasmas", Phys. Fluid, vol. 7, pp. 59-63; January, 1964.
101. Rowe, J. E., "A Large-Signal Analysis of the Traveling-Wave Amplifier: Theory and General Results", Trans. IRE-PGED, vol. ED-3, No. 1, pp. 39-57; January, 1956.