

NASA CR 54459
TPR 467-3

GPO PRICE \$ _____

CFSTI PRICE(S) \$ _____

Hard copy (HC) 2.00

Microfiche (MF) 1.50

ff 653 July 65

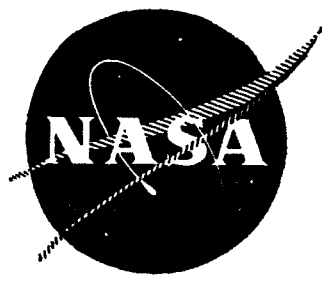

CAVITATION DAMAGE IN LIQUID METALS

by

A. Thiruvengadam, H. S. Preiser and S. L. Rudy

prepared for

NATIONAL AERONAUTICS AND SPACE ADMINISTRATION

CONTRACT NAS 3-4172

30 JUNE 1965

FACILITY FORM 803	<u>N65 31553</u> (ACCESSION NUMBER)	_____ (THRU)
	<u>33</u> (PAGES)	_____ (CODE)
	<u>OB-54459</u> (NASA CR OR TMX OR AD NUMBER)	<u>17</u> _____ (CATEGORY)

HYDRONAUTICS, incorporated research in hydrodynamics

Research, consulting, and advanced engineering in the fields of NAVAL and INDUSTRIAL HYDRODYNAMICS. Offices and Laboratory in the Washington, D. C., area: Pindell School Road, Howard County, Laurel, Md.

(over)

HYDRONAUTICS, Incorporated

NASA CR-54459

TPR 467-3

TECHNICAL PROGRESS REPORT 467-3
For the Period
1 April - 31 May 1965

CAVITATION DAMAGE IN LIQUID METALS

By

A. Thiruvengadam, H. S. Preiser and S. L. Rudy

Prepared for

National Aeronautics and Space Administration
30 June 1965
Contract NAS3-4172

Technical Management
NASA Lewis Research Center
Cleveland, Ohio
Nuclear Power Technology Branch
James P. Couch

HYDRONAUTICS, Incorporated
Pindell School Road
Laurel, Maryland

TABLE OF CONTENTS

	Page
ABSTRACT.....	1
INTRODUCTION.....	2
RESULTS AND DISCUSSION.....	2
Cavitation Damage Resistance of Five Candidate Metals.....	2
Test Conditions.....	2
Materials Tested.....	3
Cavitation Damage Test Results.....	3
High Frequency Fatigue Behavior of 316 Stainless Steel and TZM in High Temperature Sodium.....	5
Stress Corrosion Experiments on 316 Stainless Steel..	6
CONCLUSIONS.....	8
WORK TO BE ACCOMPLISHED DURING NEXT REPORTING PERIOD.....	9
REFERENCES.....	10

LIST OF FIGURES

- Figure 1 - Effect of Testing Time on Cavitation Damage Rate in 400^oF Liquid Sodium
- Figure 2 - Effect of Testing Time on the Rate of Cavitation Damage of TZM
- Figure 3 - Effect of Testing Time on the Rate of Cavitation Damage of T-222
- Figure 4 - Effect of Testing Time on the Rate of Cavitation Damage of Cb-132M
- Figure 5 - Effect of Testing Time on the Rate of Cavitation Damage of Stellite 6B
- Figure 6 - Relative Cavitation Damage Resistance of Five Metals Tested in 400^oF Sodium
- Figure 7 - Cavitation Damage Resistance of Refractory Alloys in High Temperature Liquid Sodium (1000^o and 1500^oF)
- Figure 8 - Photographs of Cavitation Damage on Refractory Metals in Pure Liquid Sodium up to 1500^oF
- Figure 9 - Relationship Between Cavitation Damage Resistance and Estimated Strain Energy
- Figure 10 - High Frequency Fatigue Curve for 316 Stainless Steel in 1000^oF Pure Liquid Sodium
- Figure 11 - Comparison of High Frequency Fatigue in 1500^oF Sodium and Low Frequency Fatigue in 1500^oF Vacuum
- Figure 12 - High Frequency Fatigue of TZM in 1000^oF Pure Liquid Sodium
- Figure 13 - High Frequency Fatigue of TZM in 1500^oF Pure Liquid Sodium
- Figure 14 - Designation for Stress Analysis in a Split Ring Specimen
- Figure 15 - Calibration of Stress Corrosion Specimen
- Figure 16 - Photograph of 316 Stainless Steel Stress Corrosion Specimens After 60 Hours Test in 1000^oF Pure Liquid Sodium (No Cracks Appeared up to 100 percent yield)

HYDRONAUTICS, Incorporated

CAVITATION DAMAGE IN LIQUID METALS

Technical Progress Report
For the Period

1 April - 31 May 1965

I. ABSTRACT

31553

Cavitation damage resistance of Stellite 6B, 316 stainless steel, Cb-132M, TZM and T-222 in liquid sodium at 400°F, 1000°F and 1500°F is reported. The test duration is an important parameter in evaluating their relative resistance. Stellite 6B exhibits the best resistance among the metals tested.

High frequency fatigue results for 316 stainless steel and TZM in liquid sodium at 1000°F and at 1500°F are presented. The fatigue of 316 stainless steel in 1500°F sodium at 14000 cps is compared with the results obtained in 1500°F vacuum (3×10^{-5} torr) at 4-5 cps and there seems to be good agreement between these results.

No stress corrosion cracking of 316 stainless steel was observed in 1000°F sodium up to 100 percent yield over a test period of 60 hours.

Author

II. INTRODUCTION

This is the third progress report of a continuing investigation on the cavitation damage resistance of refractory alloys in high temperature liquid sodium. A controlled environment test facility is being operated under this program. The details of this facility are described in References 1 and 2. Using this facility, the effect of temperature of liquid sodium on the cavitation damage resistance of 316 stainless steel was studied and the results were reported in the previous progress report (Reference 3). Further experimental results on the cavitation damage resistance of T-222, TZM, Cb-132M and Stellite 6B at 400°F, at 1000°F and 1500°F are presented in this report. In addition, high frequency fatigue of 316 stainless steel and TZM in liquid sodium at 1000°F and 1500°F is also reported. Stress corrosion experiments on 316 stainless steel in 1000°F sodium are described in this report.

III. RESULTS AND DISCUSSION

1. Cavitation Damage Resistance of Five Candidate Metals

Test Conditions

Cavitation damage tests were conducted with a magnetostriction oscillator located in a controlled environment test facility using liquid sodium. The sodium purity at 1500°F could be maintained around 35 ppm over an extended period of 8 hours (Reference 2). The test specimens were vibrated with a double amplitude of 1.36×10^{-3} inch at a frequency of about 14 kcs. The test procedure was based on the detailed study reported in Reference 4.

Materials Tested

The materials tested under this program are:

- (a) 316 stainless steel
- (b) TZM
- (c) T-222
- (d) Cb-132M
- (e) Stellite 6B

The composition and the known properties of these materials are outlined in Reference 2. While 316 stainless steel and Stellite 6B are fairly well known, the other three alloys, TZM, T-222 and Cb-132M are relatively new refractory alloys specifically developed for high temperature space applications.

Cavitation Damage Test Results

Figures 1 through 5 show the effect of testing time on the rate of damage in 400^oF sodium for all of the above five metals. A summarized presentation in Figure 6 reveals the importance of knowing these relationships for these metals in order to evaluate their resistance to cavitation damage. In the steady state zone where damage rate is independent of testing time, the five metals tested at 400^oF may be placed in the following order of merit starting from the best:

- (a) Stellite 6B
- (b) Cb-132M
- (c) T-222
- (d) TZM
- (e) 316 stainless steel

An examination of Figure 6 shows that while T-222 requires fourteen hours to reach steady state, TZM reaches the steady state in only three hours although their mechanical properties (including strain energy) alone cannot explain this large variation. The fact that the curves cross each other indicates that each one of the five metals tested exhibits its own characteristic response which is not readily understood at this stage of knowledge. We believe that an explanation of these specific response characteristics is possible through a deeper understanding of the behavior of these metals to high rates of straining at elevated temperatures and of the process of energy accumulation during repeated loading. For example, the behavior of TZM and 316 stainless steel offers an interesting comparison. While TZM exhibits a higher peak in less than fifteen minutes, 316 stainless steel damages more in the steady state. Figure 7 shows the cavitation damage resistance of the five alloys in sodium at 1000°F and 1500°F, and Figure 8 shows photographs of the cavitation damage pattern in the steady state zone (with the exception of Stellite) after exposure to 1500°F sodium.

A typical plot of the reciprocal of the rate of volume loss versus their estimated (approximate) strain energies as given in Reference 2 for the four metals at normal strain rates (at which metals are generally tested) is shown in Figure 9. The data for Stellite 6B is not plotted since it was not tested in the steady state zone. In spite of the irregular behavior pointed out above, the data obtained generally confirm the earlier findings that the energy absorption characteristics of metals during

fracture represent their cavitation damage resistance. However, much more detailed and intensive investigations are necessary for confirming these relatively limited results because of the lack of mechanical properties at these temperatures and at these high strain rates. In fact, it has recently come to our attention that the strain energy estimated for TZM in this report was based on the short time tensile strength of the recrystallized material. The short time tensile strength of stress-relieved, as-rolled TZM is 30 percent lower than that of the recrystallized form.

2. High Frequency Fatigue Behavior of 316 Stainless Steel and TZM in High Temperature Sodium

To understand the relationship between the cavitation damage resistance and the environmental fatigue behavior of metals, high frequency fatigue tests on 316 stainless steel and TZM were conducted in liquid sodium at two temperatures (1000°F and 1500°F). The basic principle of the testing method is to produce the required alternating stresses in a properly designed fatigue specimen by means of the magnetostriction oscillator. The details of this technique and the design procedures have been described in Reference 2.

Part of the test program has been completed during this reporting period. The test parameters developed under this program for the successful operation of these tests are summarized in Table 1. Figures 10 through 13 show the results of these fatigue tests for 316 stainless steel and for TZM at two temperatures (1000°F and 1500°F) in pure sodium. In Figure 11

the results of low frequency (4-5 cps) fatigue tests on 316 stainless steel at 1500^oF in 3×10^{-5} torr vacuum (Reference 5) are shown along with the data obtained from the present high frequency fatigue data in 1500^oF sodium at 14000 cps. In addition, the steep decrease in stress level of TZM (See Figure 13 for example) points out the brittle nature of TZM at these temperatures. The large scatter of the data for TZM can be accounted for by (a) the cold working properties, (b) the relative inhomogeneity of this metal and (c) possibility of machining irregularities. The TZM specimens were prepared from 1/2 inch diameter rod stock which was initially stress relieved for 1/2 hour at 2250^oF. However, no further heat treatment was applied after machining and polishing the fatigue specimens. The same remarks are applicable to the cavitation damage specimens.

Further fatigue experiments have been planned in sodium with 200 ± 50 ppm O₂ impurity to study effect of O₂ impurities on these two metals at temperatures of 1000^oF and 1500^oF.

3. Stress Corrosion Experiments on 316 Stainless Steel

Another aspect of this program is related to the study of the stress corrosion behavior of 316 stainless steel and TZM in high temperature liquid sodium. For this purpose, a split ring type of stress corrosion specimen has been selected. The relative merits of this type of specimen have already been discussed (Reference 2). During this reporting period, 316 stainless steel specimens were fabricated and tested at various stress levels after calibration.

The relationship between the maximum deflection δ_v produced by a load P in a thin split ring of thickness, d and breadth, b (see Figure 14), is given by the following equation (Reference 6):

$$\delta_v = \frac{6\pi Pr^3}{E bd^3} \quad [1]$$

where

E is the modulus of elasticity of the material, and
r is the radius of the thin ring.

Figure 15 shows the comparison between theory and actual measured values of load and deflection by means of a variable reluctance force gage. Furthermore, the maximum fibre stress corresponding to a deflection δ_v is given by

$$\sigma = \frac{Ed\delta_v}{\pi r^2} \quad [2]$$

By fabricating the entire specimen assembly from the same material, no additional stresses will be introduced upon heating as all parts will expand equally - however, the appropriate value of the Youngs modulus E for the given temperature must be used in calculating the stresses.

A 60 hour test was performed in 1000^oF liquid sodium (\approx 35 ppm O₂ impurity) on 316 stainless steel at 3 stress levels (100 percent, 75 percent and 50 percent of yield strength). However, no stress corrosion cracking was observed in this test as shown in Figure 16.

IV. CONCLUSIONS

The following conclusions may be drawn from results obtained thus far under this program.

1. Relative cavitation damage resistance exhibited by the five high temperature alloys tested in this program depends upon zone of damage in which the comparison is made. This result further emphasizes the necessity for obtaining detailed information on all the four zones of damage for a meaningful comparison.

2. Among the metals tested, Stellite 6B seems to possess the best cavitation damage resistance. Incidentally, this metal possesses the highest estimated strain energy among the metals tested.

3. While there is general evidence that the energy absorbing characteristics of these metals during fracture represent the cavitation damage resistance, much more detailed information is necessary in this area of research at high temperatures and at high strain rates.

4. A comparison between the fatigue data at 4-5 cps using 316 stainless steel in 3×10^{-5} torr vacuum at 1500°F and the fatigue data at 14000 cps for the same metal in 1500°F liquid sodium does not show much deviation between the two results. This result points out the absence of strain rate effects and corrosion fatigue effects in the present fatigue tests with 316 stainless steel.

5. The stress corrosion test on 316 stainless steel in 1000°F liquid sodium up to a stress of 100 percent yield did not show any cracking over a test period of 60 hours.

V. WORK TO BE ACCOMPLISHED DURING NEXT REPORTING PERIOD

During the next reporting period it is planned to complete the fatigue tests to determine the effect of 200 ppm O_2 contamination in liquid sodium. The stress corrosion experiments will be completed. A few more tests on the cavitation damage resistance of 316 stainless steel and TZM in liquid sodium contaminated with 200 ppm oxygen will be conducted. The data will be analyzed and the final report will be prepared.

REFERENCES

1. Preiser, H. S., Thiruvengadam, A. and Couchman, C. III, "Cavitation Damage in Liquid Sodium," NASA CR-54071, TR-235-1, HYDRONAUTICS, Incorporated, Laurel, Maryland, April 1964.
2. Couchman, C. III, Preiser, H. S., and Thiruvengadam, A., "Cavitation Damage in Liquid Metals," NASA CR-54332, TPR-467-1, HYDRONAUTICS, Incorporated, Laurel, Maryland, 10 March 1965.
3. Thiruvengadam, A., Preiser, H. S., and Rudy, S. L., "Cavitation Damage in Liquid Metals," NASA CR-54391, TPR-467-2, HYDRONAUTICS, Incorporated, Laurel, Maryland, 28 April 1965.
4. Thiruvengadam, A., and Preiser, H. S., "On Testing Materials for Cavitation Damage Resistance," HYDRONAUTICS, Incorporated Technical Report 233-3, December 1963. (See also Jour. Ship Research, Vol. 8, No. 3, December 1964).
5. Danek, G. J., Jr., and Achter, M. R., "A High-Temperature Vacuum, and Controlled Environment Fatigue Tester," ASTM Bulletin No. 234, pp. 48-52, December 1958.
6. Timoshenko, S., "Strength of Materials," Part I, D. Van Nostrand Company, Incorporated, 3rd Ed., p. 378, 1955.

TABLE 1
 Test Parameters of High Frequency Fatigue Specimens

Metal	Temp. °F	Wave Length Inches	Modulus of Elasticity- psi x 10 ⁻⁶	Specimen Length-Inches	Resonant Frequency cps
316 Stainless Steel	1000	12.2	21.8	5.500	14140
	1500	11.3	18.5	5.125	14080
TZM	1000	15.0	42.0	7.000	13990
	1500	14.5	39.0	6.750	14080

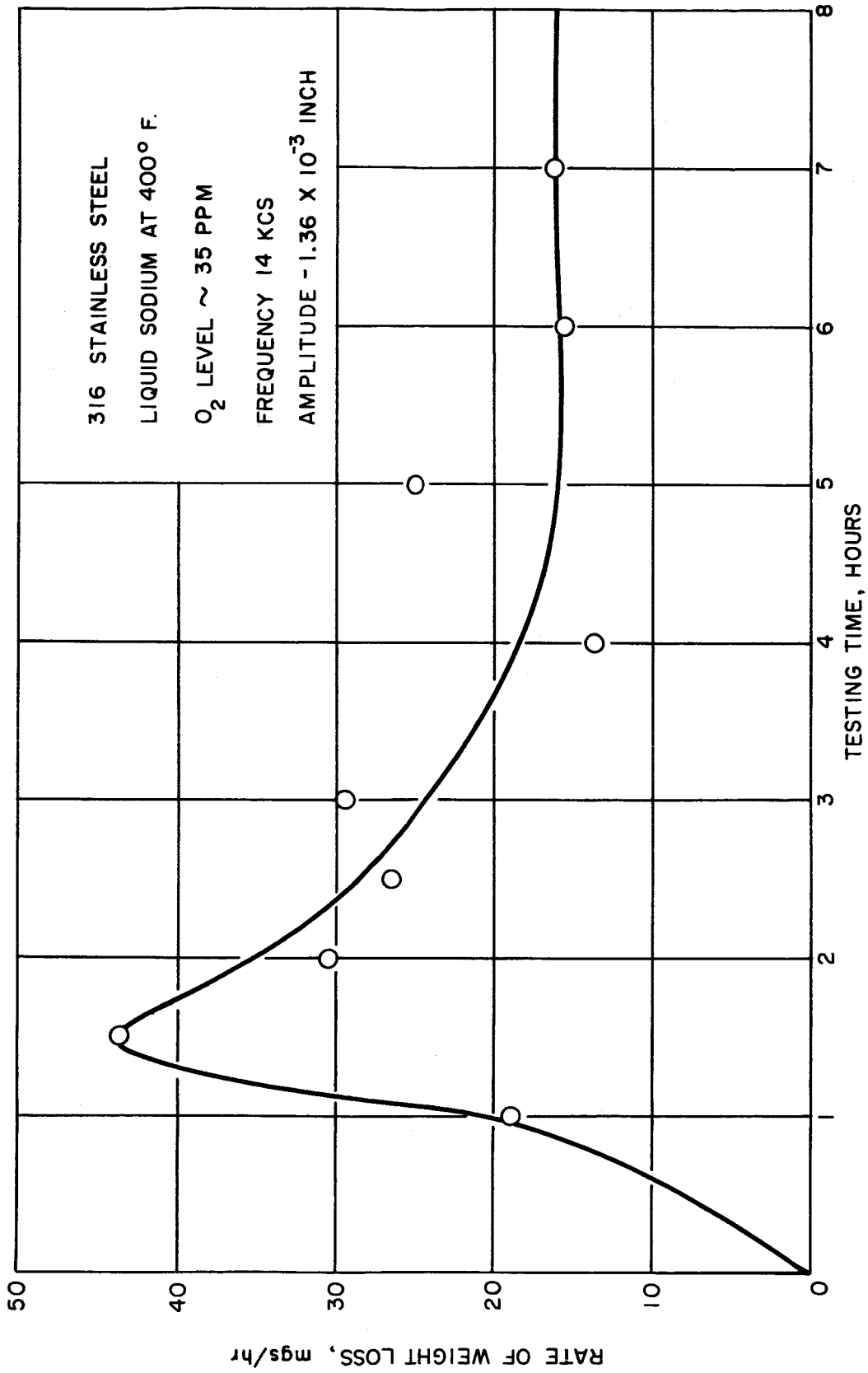

FIGURE 1- EFFECT OF TESTING TIME ON CAVITATION DAMAGE RATE IN 400° F, LIQUID SODIUM

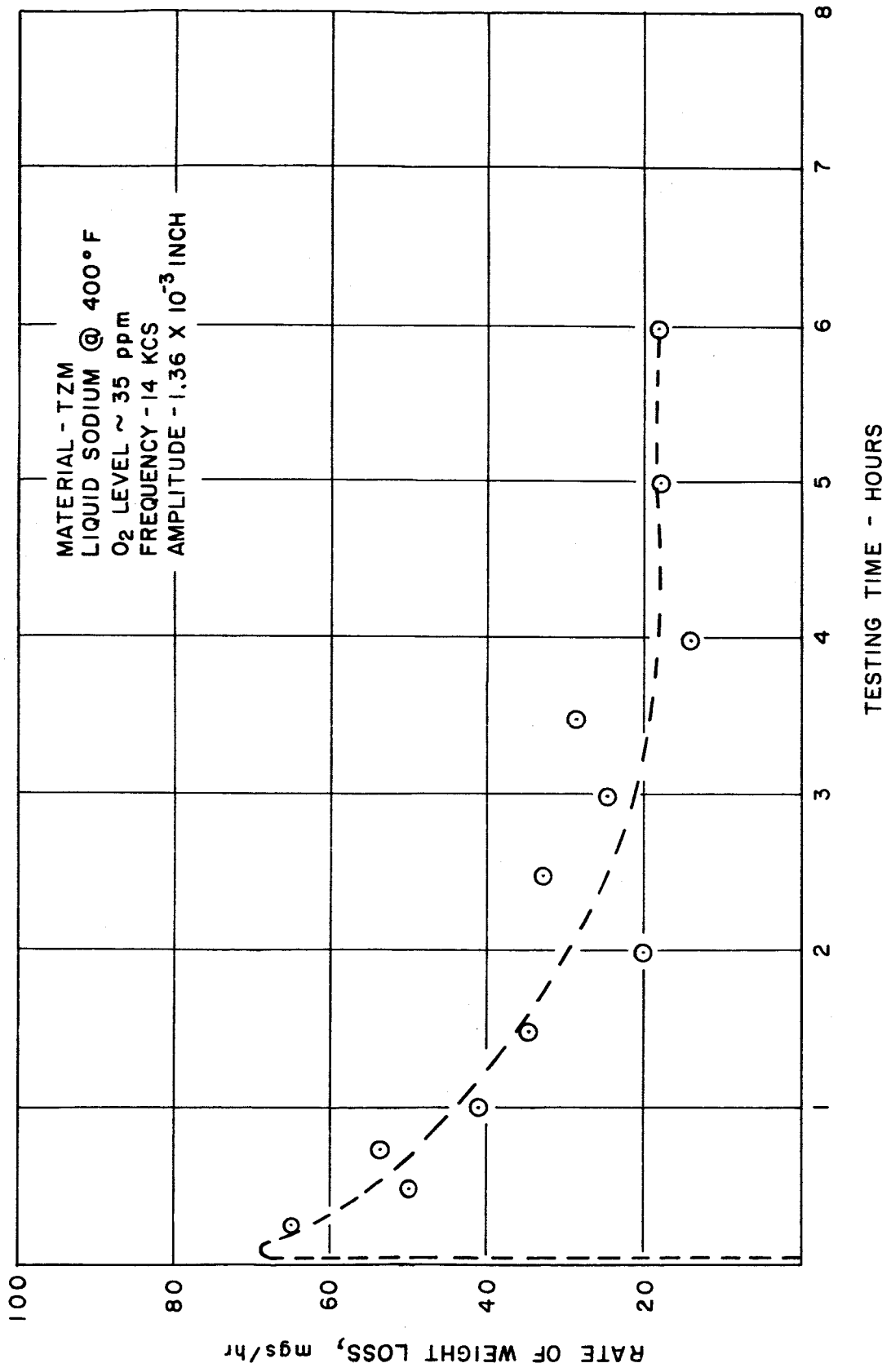

FIGURE 2 - EFFECT OF TESTING TIME ON THE RATE OF CAVITATION DAMAGE OF TZM

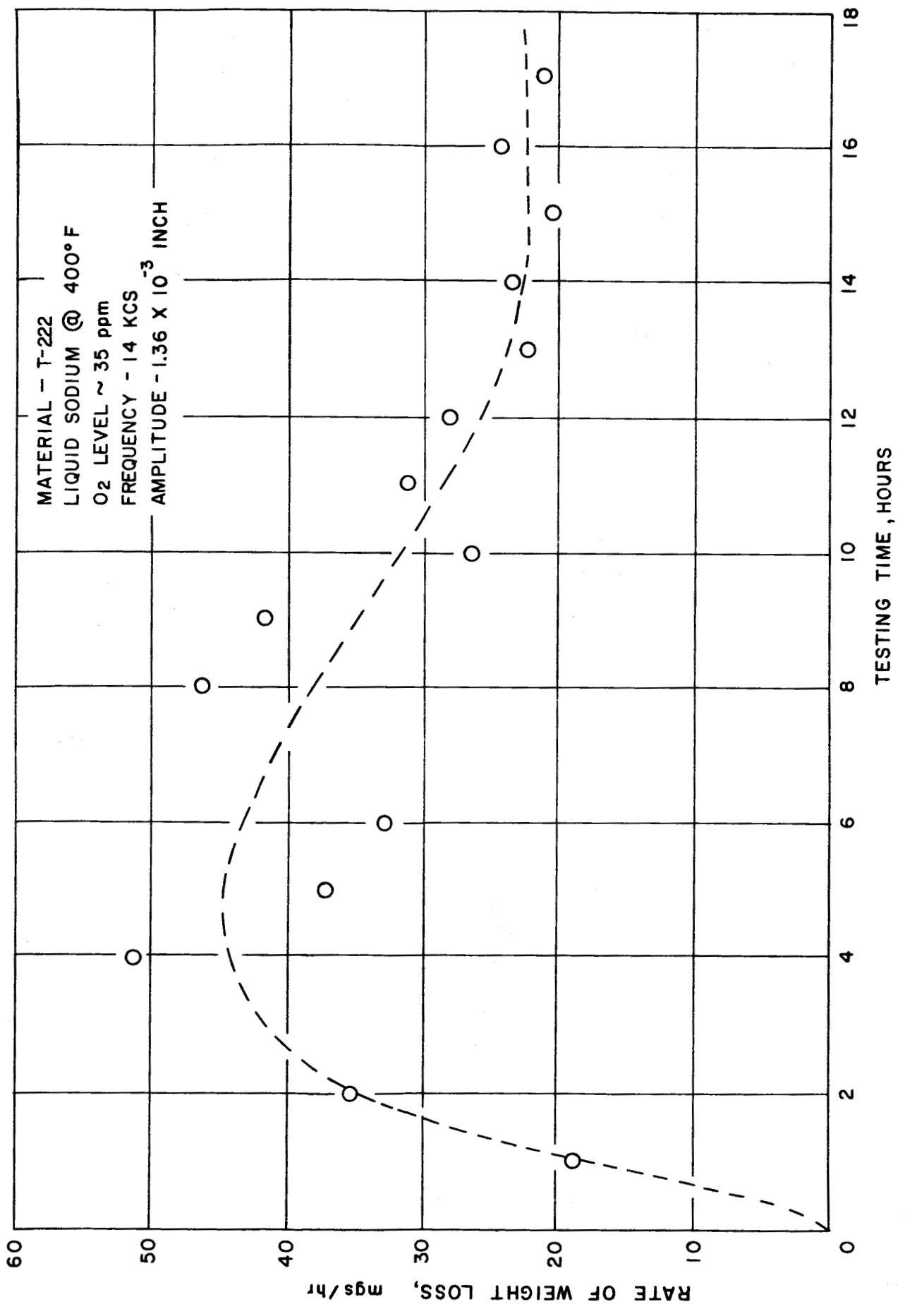

FIGURE 3 - EFFECT OF TESTING TIME ON THE RATE OF CAVITATION DAMAGE OF T-222

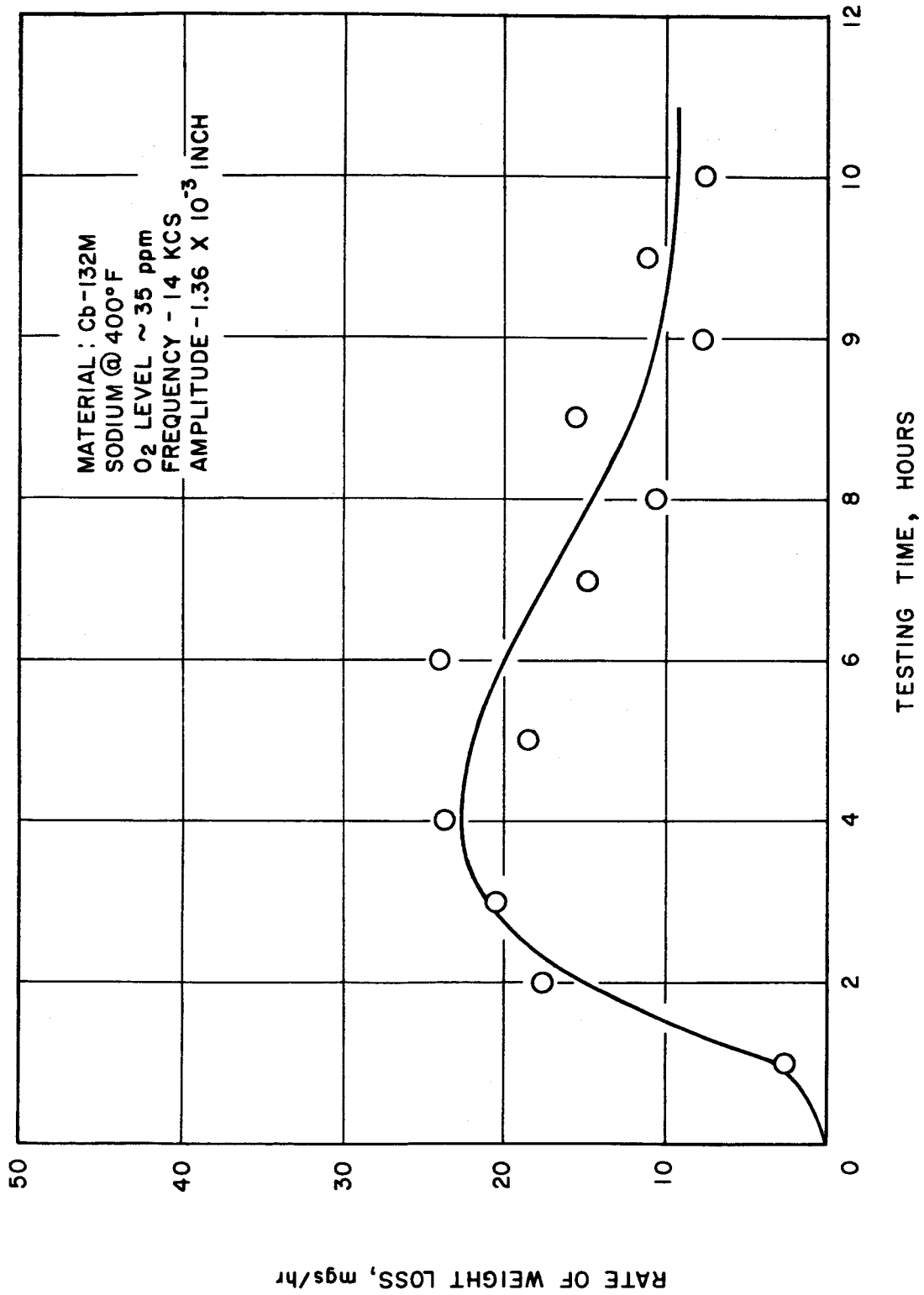

FIGURE 4 - EFFECT OF TESTING TIME ON THE RATE OF CAVITATION DAMAGE OF Cb-132M

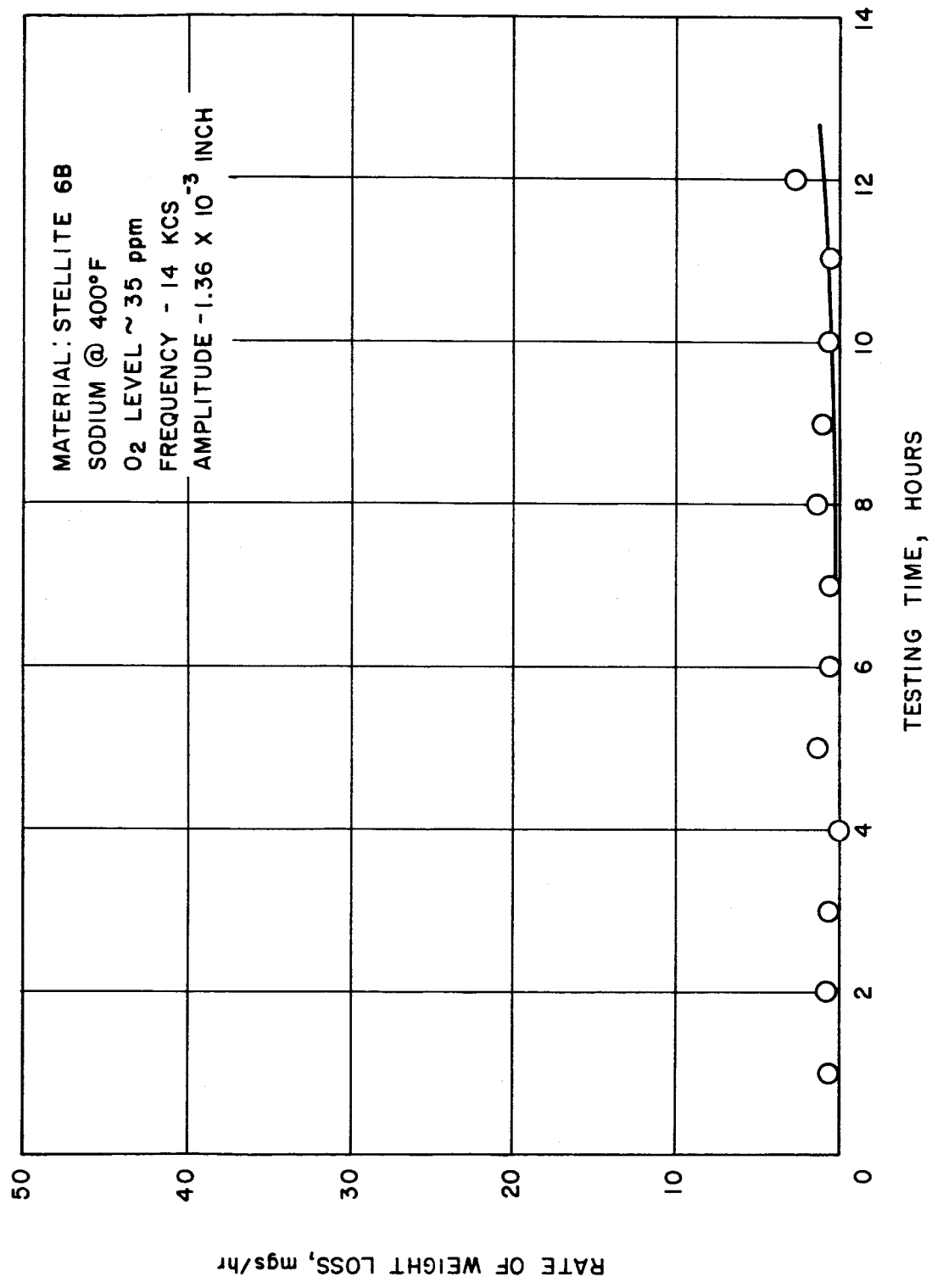

FIGURE 5- EFFECT OF TESTING TIME ON THE RATE OF CAVITATION DAMAGE OF STELLITE 6B

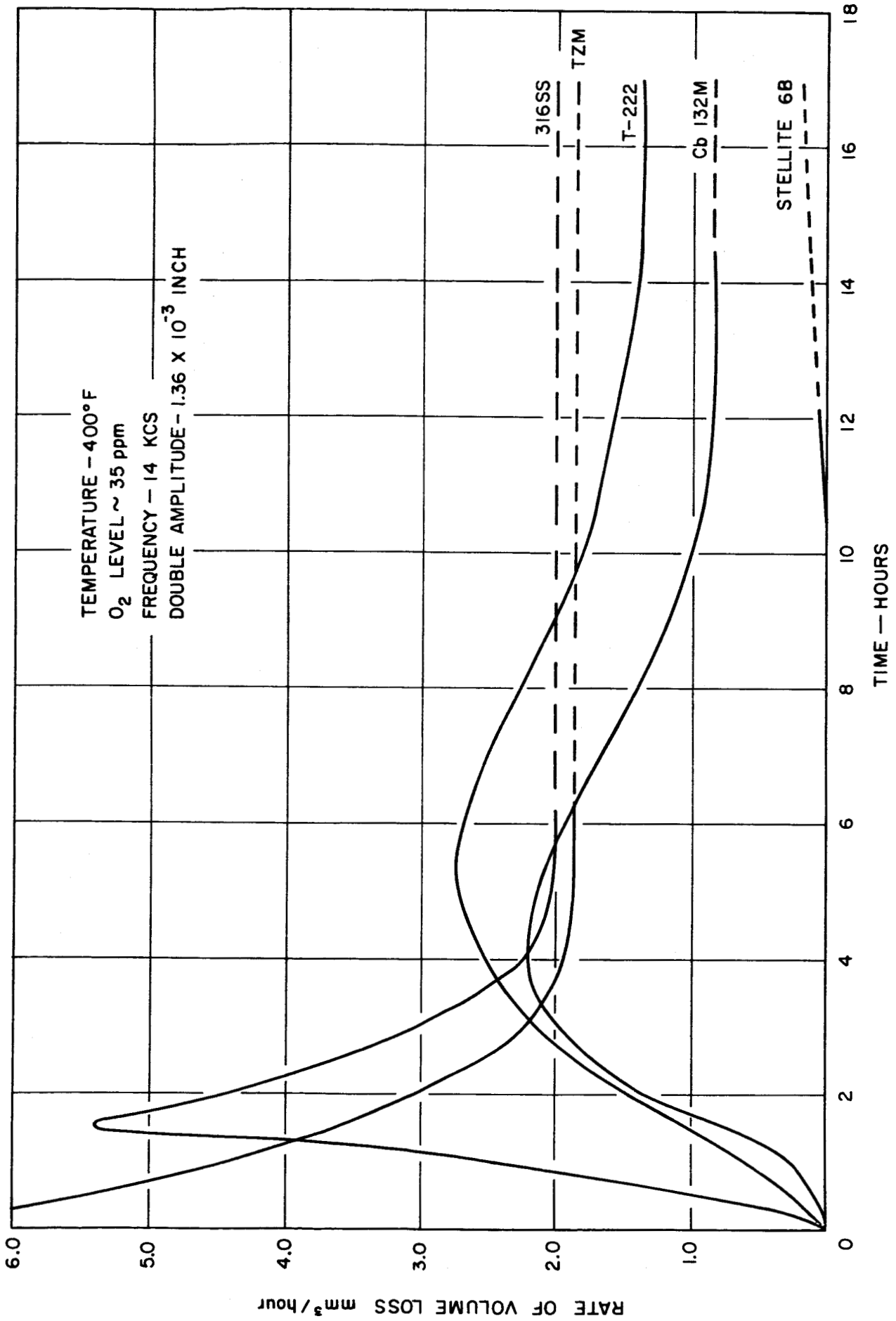

FIGURE 6—RELATIVE CAVITATION DAMAGE RESISTANCE OF FIVE METALS TESTED IN 400° F SODIUM

HYDRONAUTICS, INCORPORATED

FREQUENCY - 14 KCS
 DOUBLE AMPLITUDE - 1.36×10^{-3} INCH
 O_2 LEVEL ~ 35 ppm

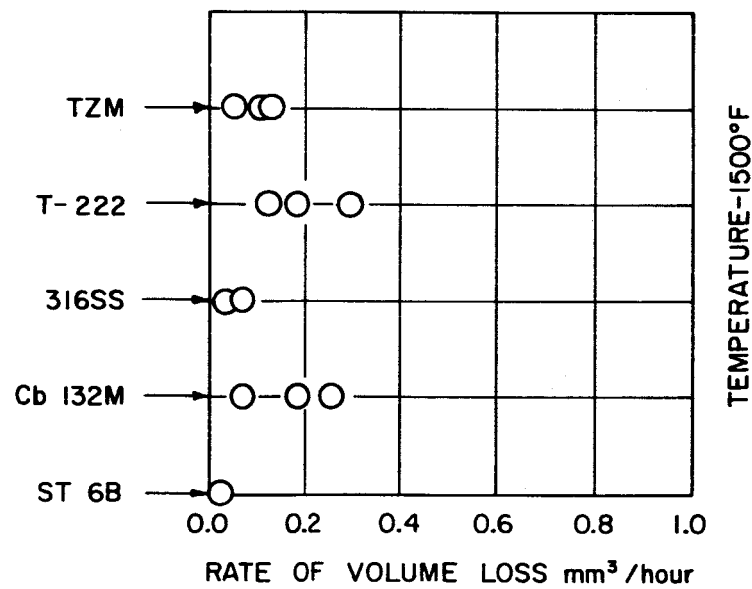
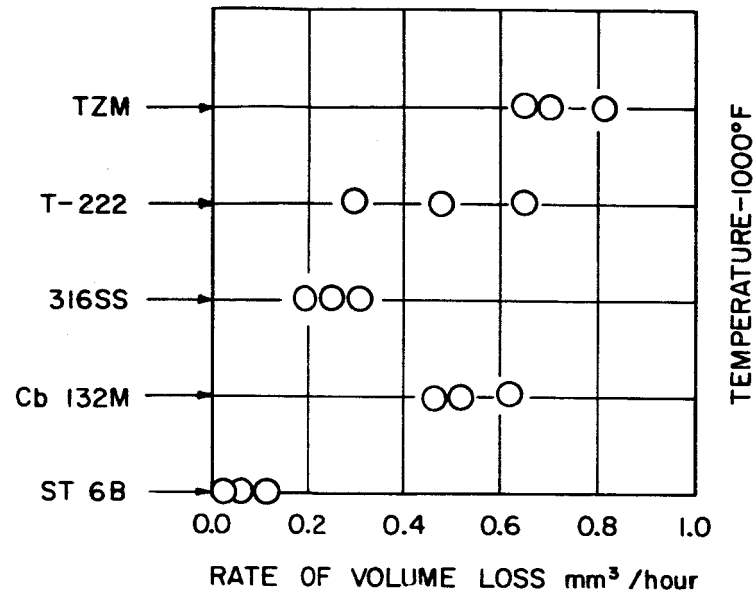
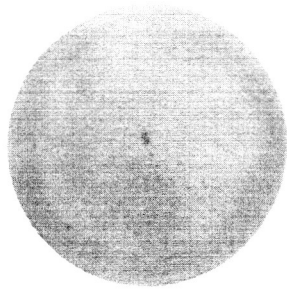
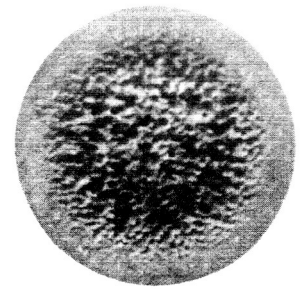

FIGURE 7 - CAVITATION DAMAGE RESISTANCE OF REFRACTORY ALLOYS
 IN HIGH TEMPERATURE LIQUID SODIUM
 (1000° AND 1500° F)

HYDRONAUTICS, INCORPORATED



STELLITE 6B



CB132

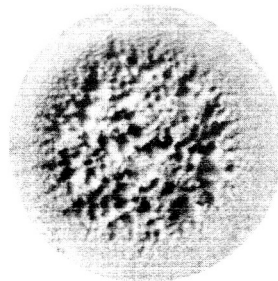

316 SS

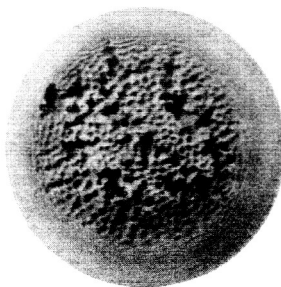

TZM

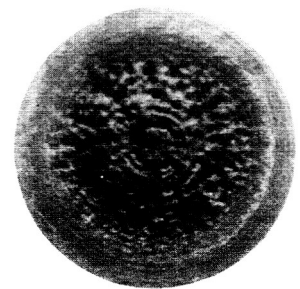

T-222

FIGURE 8 - PHOTOGRAPHS OF CAVITATION DAMAGE ON REFRACTORY METALS IN PURE LIQUID SODIUM UP TO 1500°F

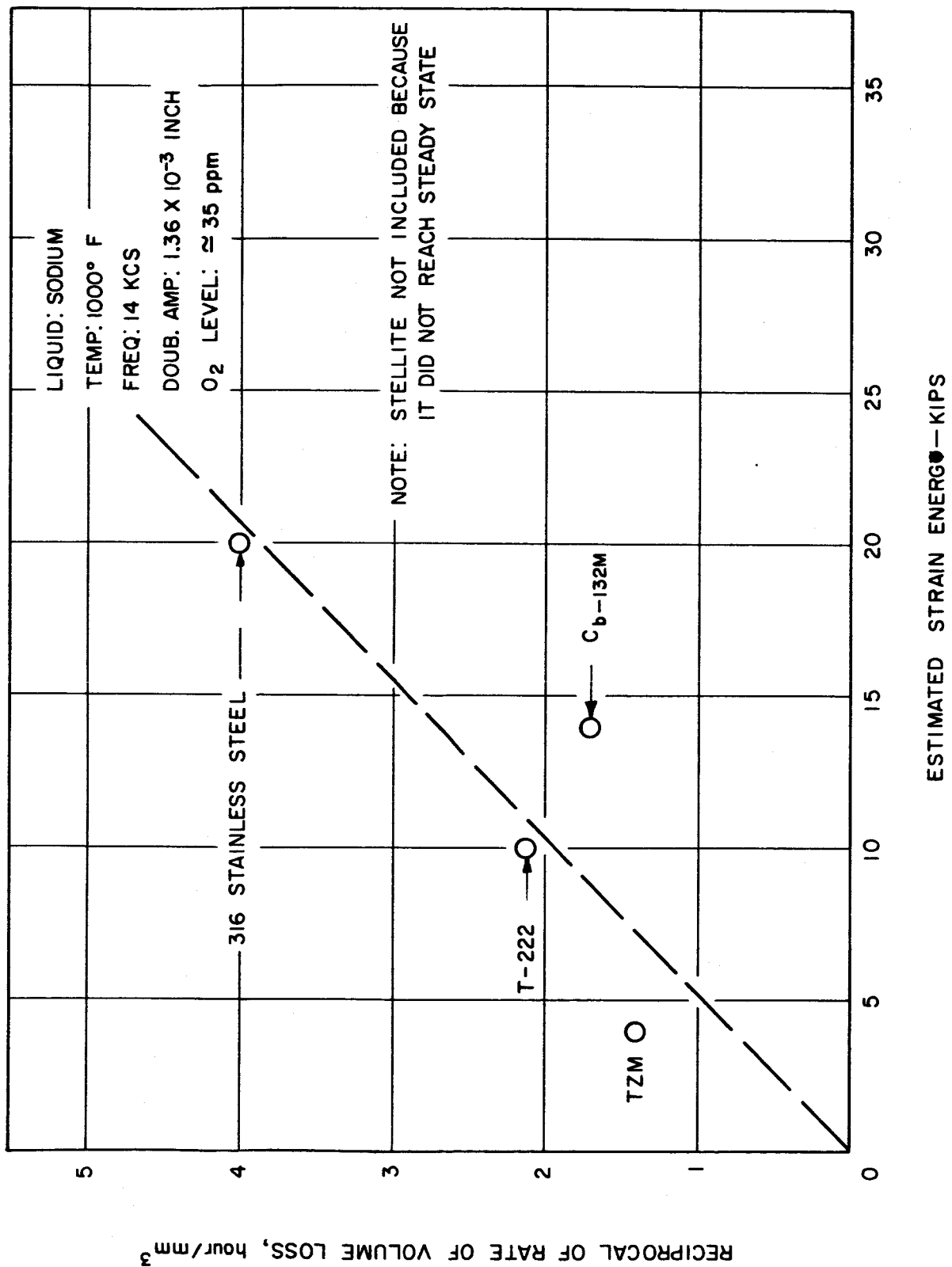

FIGURE 9 - RELATIONSHIP BETWEEN CAVITATION DAMAGE RESISTANCE AND ESTIMATED STRAIN ENERGY

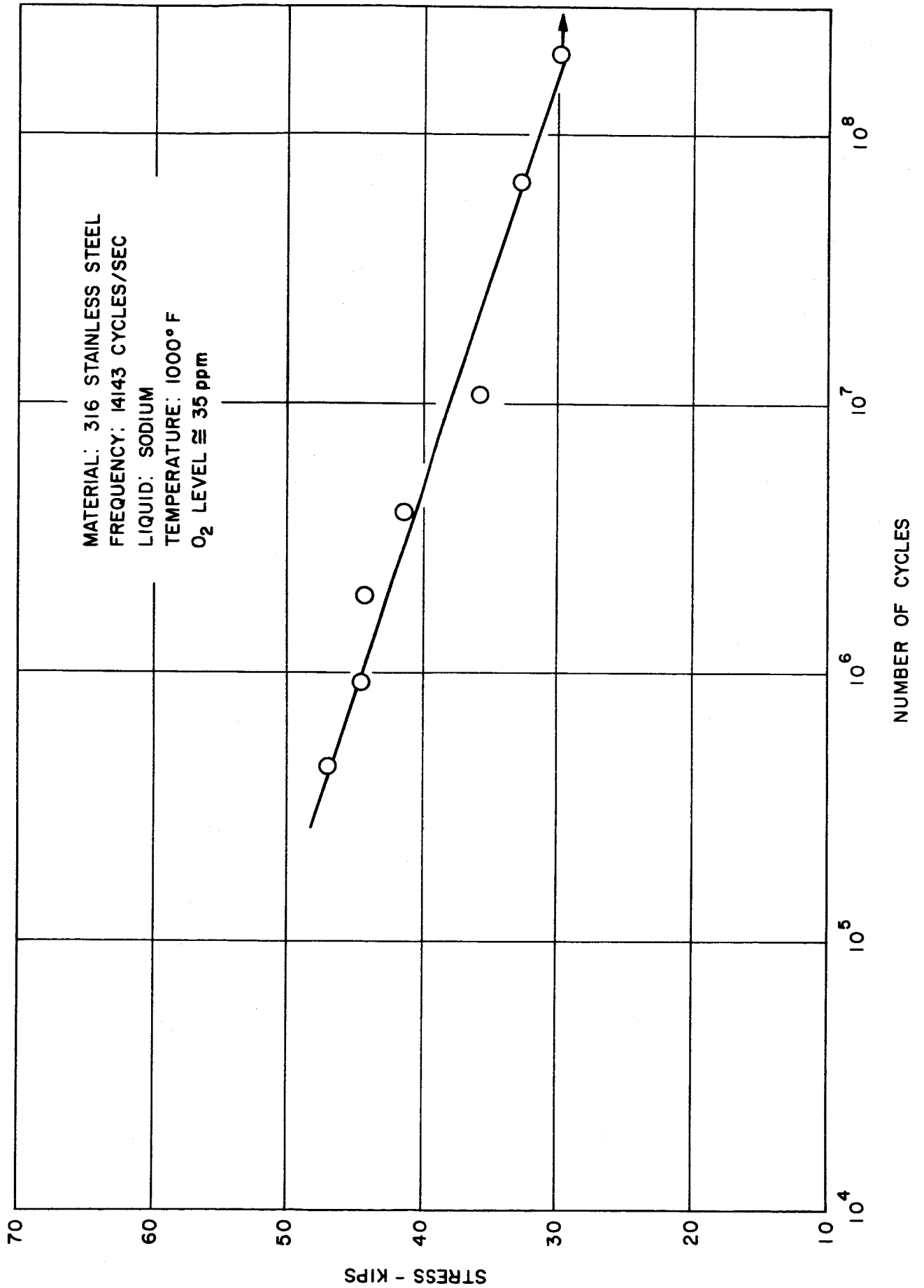

FIGURE 10— HIGH FREQUENCY FATIGUE CURVE FOR 316 STAINLESS STEEL IN 1000°F PURE LIQUID SODIUM

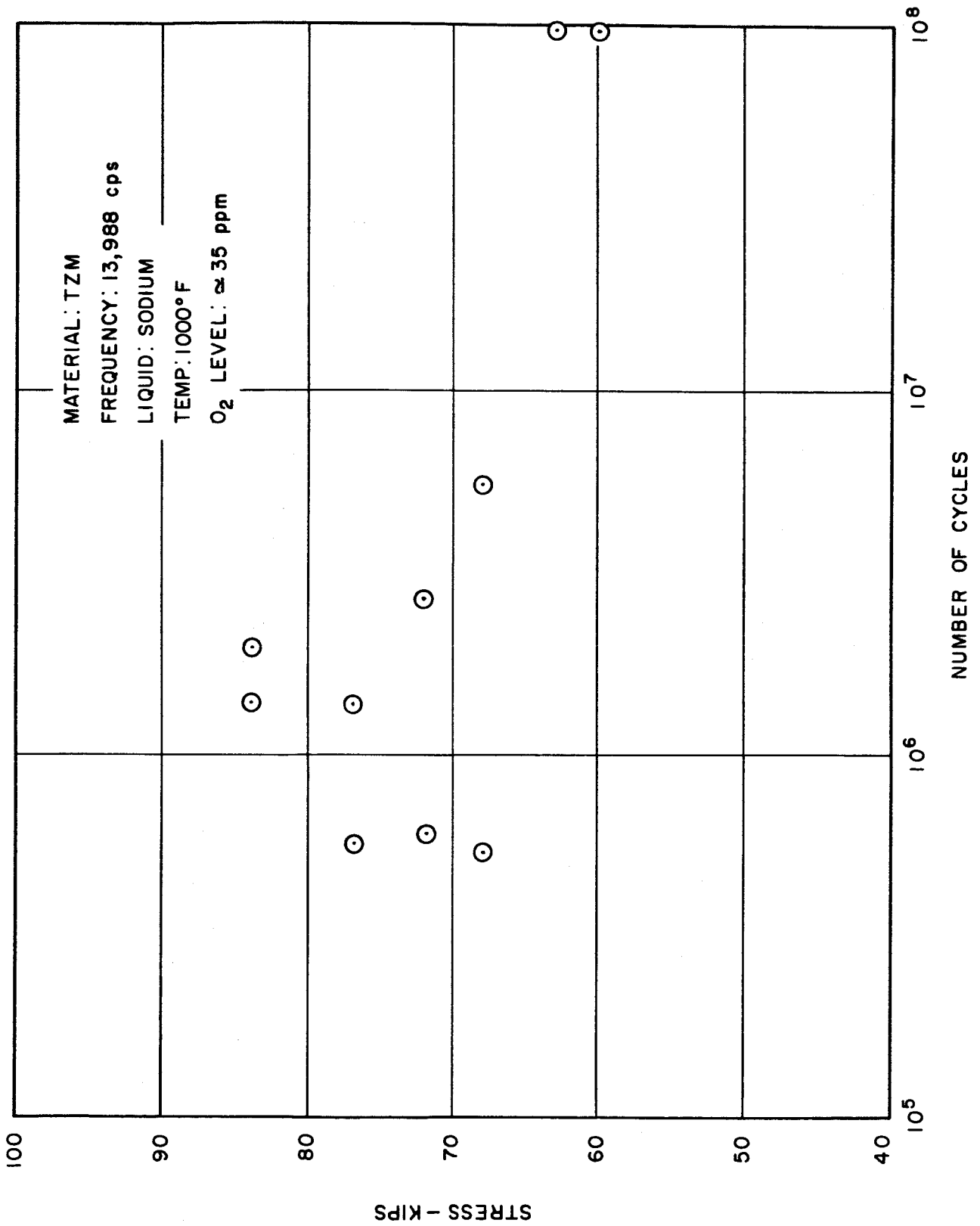

FIGURE 12 — HIGH FREQUENCY FATIGUE OF TZM IN 1000°F PURE LIQUID SODIUM

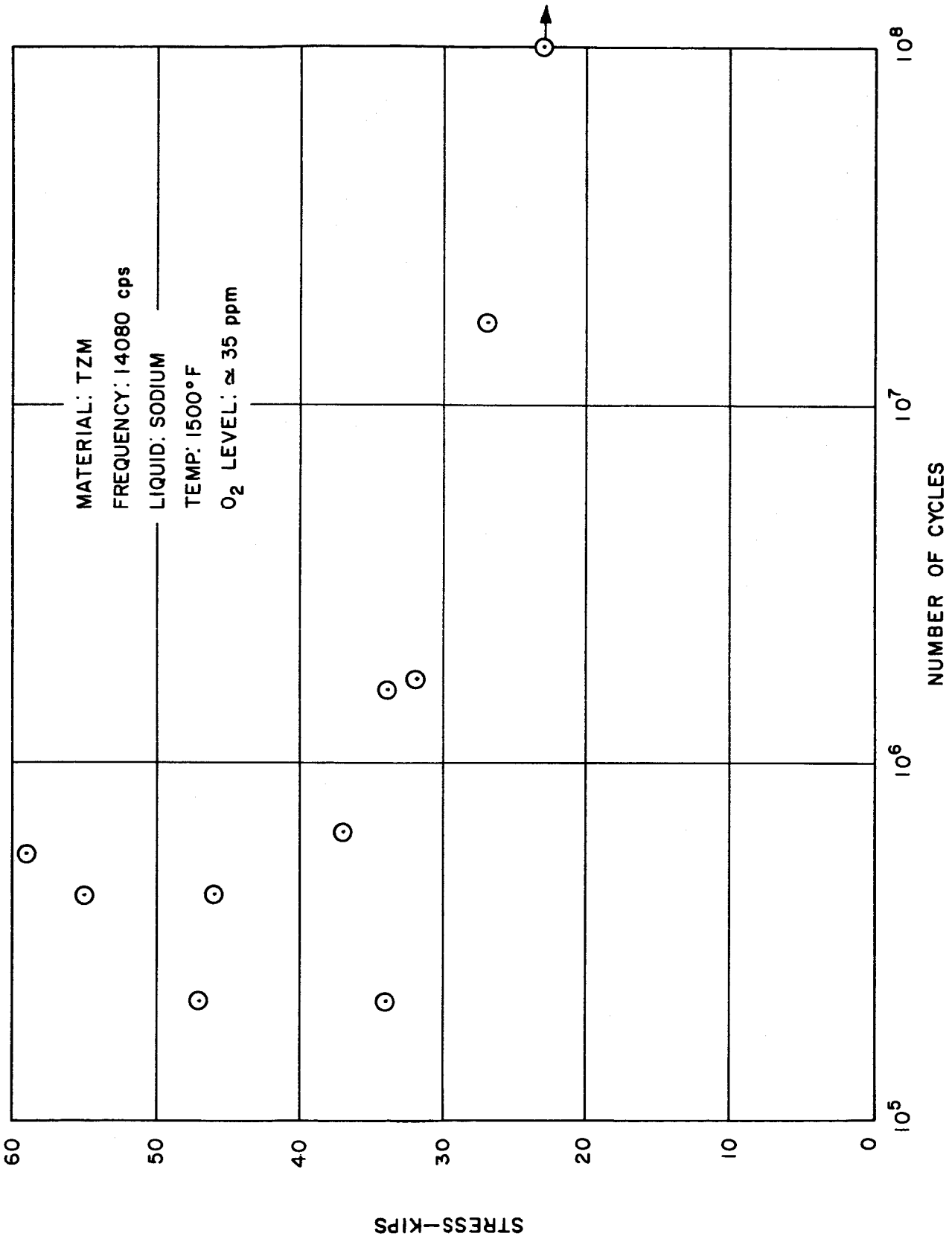

FIGURE 13—HIGH FREQUENCY FATIGUE OF TZM IN 1500°F PURE LIQUID SODIUM

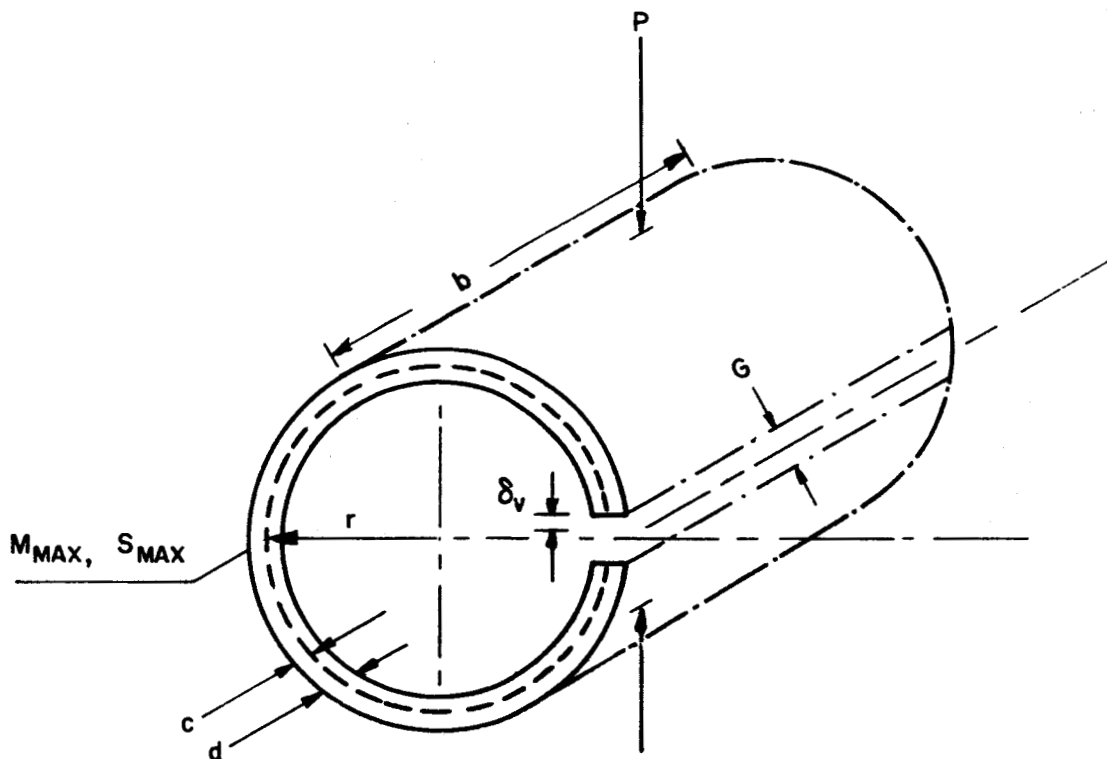

FIGURE 14- DESIGNATION FOR STRESS ANALYSIS IN A SPLIT RING SPECIMEN

$$S = \frac{Prd}{2I} = \frac{P \times 10^4 \text{ KIPS}}{3}$$

$$S = \frac{\delta_v d E}{\pi r^2} = 4.42 \delta_v \times 10^6 \text{ KIPS}$$

$$r = 1/4''$$

$$d = .030''$$

$$I = bd^3/12$$

$$E = 28 \times 10^6 \text{ psi}$$

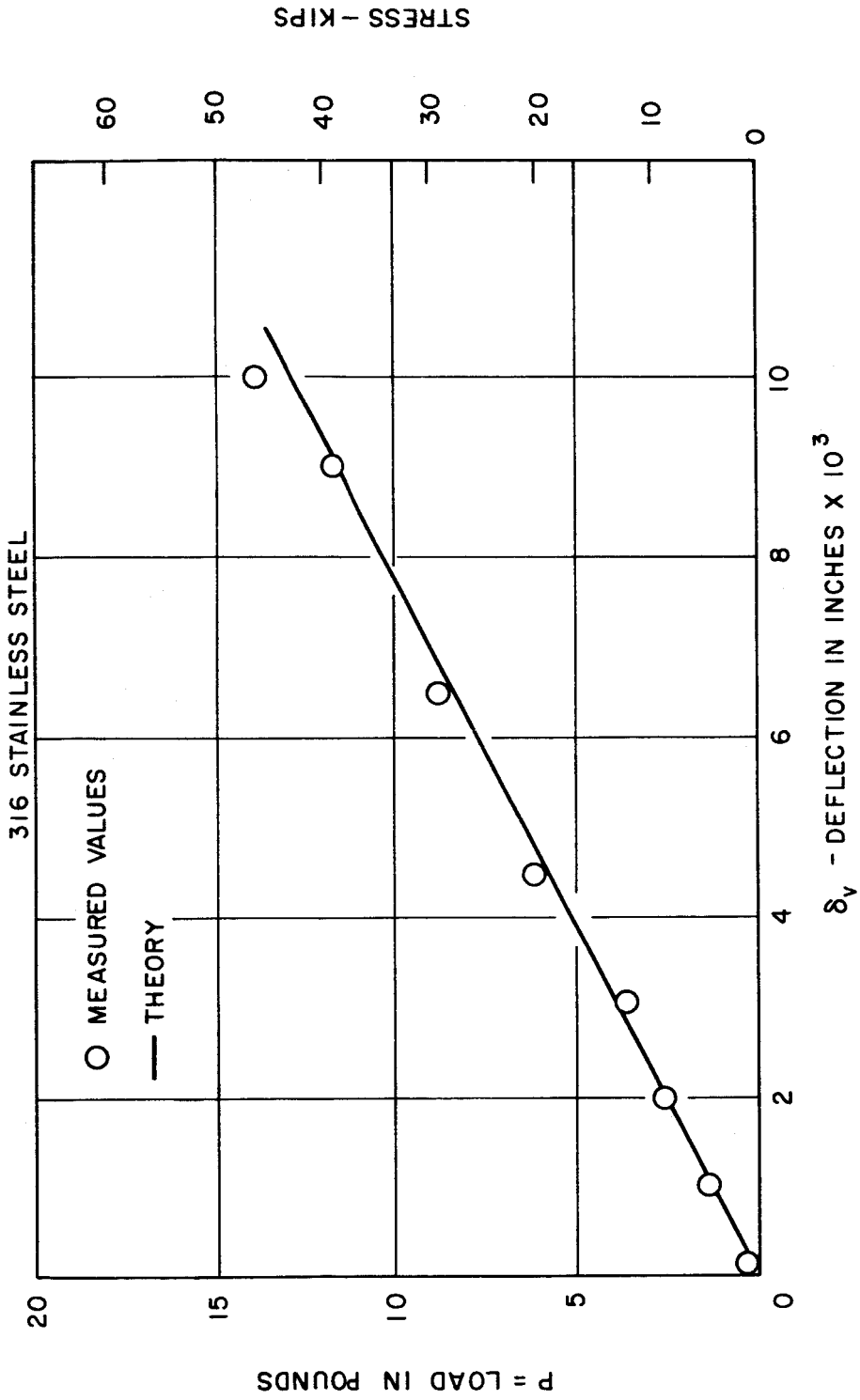

FIGURE 15 - CALIBRATION OF STRESS CORROSION SPECIMEN

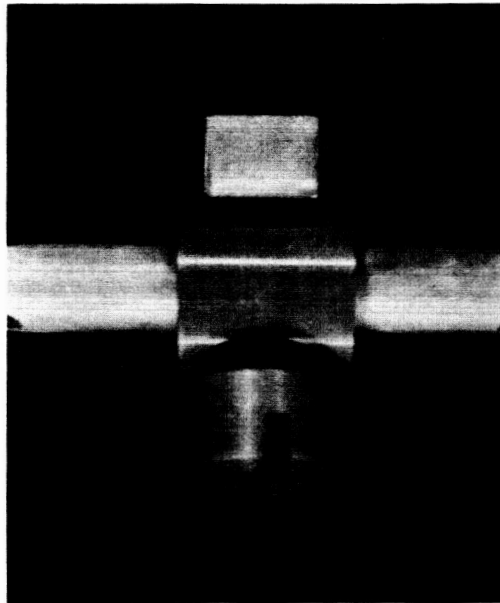
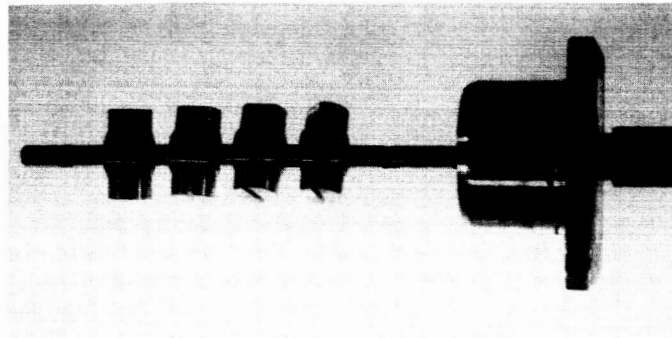

FIGURE 16 - PHOTOGRAPH OF 316 STAINLESS STEEL STRESS CORROSION SPECIMENS AFTER 60 HOURS TEST IN 1000°F PURE LIQUID SODIUM. (NO CRACKS APPEARED UP TO 100% YIELD)

HYDRONAUTICS, Incorporated

DISTRIBUTION LIST
(Contract No. NAS3-4172)

National Aeronautics and Space Administration Washington, D. C. 20546 Attn: J. J. Lynch (RNP)	1	NASA-Marshall Space Flight Center Huntsville, Alabama 35812 Attn: Library	1
U. S. Atomic Energy Commission Washington, D. C. 20545 Attn: H. D. Rothen (SNAP-50/SPUR) NASA-AEC Deputy	1	NASA-Scientific and Technical Information Facility Box 5700 Bethesda, Maryland 20014 Attn: NASA Representative	2
NASA-Ames Research Center Moffett Field, California 94035 Attn: Library	1	Jet Propulsion Laboratory 4800 Oak Grove Drive Pasadena, California 91103 Attn: Library	1
NASA-Langley Research Center Langley Station Hampton, Virginia 23365 Attn: Library	1	Argonne National Laboratory P. O. Box 299 Lemont, Illinois 60439 Attn: Library	1
NASA-Lewis Research Center 21000 Brookpark Road Cleveland, Ohio 44135 Attn: J. E. Dilley (500-309) Dr. B. Lubarsky (500-201) R. F. Mather (500-309) J. P. Couch (500-309) M. J. Hartmann (5-9) C. H. Hauser (5-9) S. G. Young (49-1) Library (3-7) Office of Reliability and Quality Assurance (500-203) Technology Utilization Office (3-16) Report Control Office (5-5)	1 1 1 1 1 1 1 1 1 1 1	Brookhaven National Laboratory Upton, New York 11973 Attn: Dr. O.E. Dwyer Library U. S. Atomic Energy Commission Division of Technical Information Extension P. O. Box 62 Oak Ridge, Tennessee 37831 Air Force Materials Laboratory Research and Technology Division Air Force Systems Command Wright-Patterson AFB, Ohio 45433 Attn: K. A. David (MANL)	1 1 1 1 2 1

HYDRONAUTICS, Incorporated

-3-

Lockheed Missiles and Space Division
Sunnyvale, California
Building 526, Dept. 65-33
Attn: John N. Cox
Staff Engineer 1

United Aircraft Corporation
Pratt and Whitney Aircraft Division
East Hartford, Connecticut 06108
Attn: Librarian 2

Dr. James Hadley
Head, Reactor Division
Lawrence Radiation Laboratory
Livermore, California 1

Aeronautical Systems Division
Wright-Patterson Air Force Base
Ohio
Attn: Mr. George E. Thompson
APIP-1 1
Mr. George Sherman
API 1

U. S. Atomic Energy Commission
Germantown, Maryland
Attn: Col. E. L. Douthett 1

National Aeronautics and Space
Administration
Lewis Research Center
21000 Brookpark Road
Cleveland, Ohio 44135
Attn: Mr. I. I. Pinkel 1
Dr. L. Rosenblum 1

HYDRONAUTICS, Incorporated

ERRATA

Please make the following corrections to the first technical progress report, "Cavitation Damage In Liquid Metals," by C. E. Couchman, III, H. S. Preiser and A. Thiruvengadam, NASA CR-54332, TPR 467-1, HYDRONAUTICS, Incorporated, Laurel, Maryland, 10 March 1965.

Page 16: Formula should be changed to read correctly as follows:

$$\frac{1}{Q} = \alpha = \frac{\pi}{\sqrt{3}} \frac{\Delta f}{f_n}$$

Page 23: First sentence should read - (2) Stellite 6B - A cobalt based alloy with a relatively moderate (1.1 percent) carbon content, making it one of the easier of the cobalt alloys to form and work.

Page 23: 3rd paragraph, last line should read - Excellent corrosion resistance is probably due to the formation of hafnium carbides.