



# Department of AERONAUTICS and ASTRONAUTICS STANFORD UNIVERSITY

Fourth Semiannual Status Report

November 1965

*Temp #  
26113*

on the Engineering Portion of a Research Program To  
**DEVELOP A ZERO-g, DRAG-FREE SATELLITE**  
and To  
**PERFORM A GYRO TEST OF GENERAL RELATIVITY IN A SATELLITE**

GPO PRICE \$ \_\_\_\_\_  
CFSTI PRICE(S) \$ \_\_\_\_\_  
Hard copy (HC) 2.00  
Microfiche (MF) 50

at  
Stanford University

under

FF 653 July 65

Research Grant NsG-582

from the

National Aeronautics and Space Administration

**N66-17078**

FACILITY FORM 602

(ACCESSION NUMBER)	(THRU)
<u>28</u>	<u>1</u>
(PAGES)	(CODE)
<u>CR 70305</u>	<u>31</u>
(NASA CR OR TMX OR AD NUMBER)	(CATEGORY)

(Principal investigators for the engineering portion of the program are Professor Robert H. Cannon, Jr. and Professor Benjamin Q. Lange.)

Fourth Semiannual Status Report

November 1965

on the Engineering Portion of a Research Program To

DEVELOP A ZERO-g, DRAG-FREE SATELLITE

and To

PERFORM A GYRO TEST OF GENERAL RELATIVITY IN A SATELLITE

at

Stanford University

under

Research Grant NsG-582

from the

National Aeronautics and Space Administration

(Principal investigators for the engineering portion of the program are Professor Robert H. Cannon, Jr. and Professor Benjamin O. Lange.)

## I. INTRODUCTION

Stanford University is engaged in a program to develop a scientific zero-g satellite, and to perform a gyro test of general relativity in a satellite. The program was conceived by Stanford in 1961 and is described in detail in a proposal for support [Ref. 1] submitted to NASA in November 1962, and in Engineering Status Reports No. 1 [Ref. 2], No. 2 [Ref. 3], and No. 3 [Ref. 4].

On the basis of Ref. 1, a grant, NsG-582, was awarded to Stanford by NASA on 8 May 1964, with a retroactive starting date of 1 October 1963. The present report describes research performed in the Department of Aeronautics and Astronautics during the fourth half-year of the NASA grant period, from May 1965 through October 1965, and discusses the present status of the program.

A detailed preliminary analysis of the dynamics, control and uses of the drag-free satellite and of unsupported gyroscopes, along with a trajectory error analysis and a gyro random-drift-error analysis are given in Refs. 5, 6, and 7.

A systematic program of breadboard development and simulated operation of a two-dimensional "zero-g, drag-free satellite" in the laboratory, using an air-cushion vehicle, has been described in previous status reports, particularly Ref. 4. During the present report period this research reached the point where, we believe, feasibility of the zero-g satellite concept has been established, so that the next step to take is a program to prove out the concepts in flight. Accordingly, a major effort was devoted, during the present report period, to developing a flight program that will be of scientific value and will also permit thorough flight evaluation of a zero-g satellite control system. A flight proposal for an aeronomy experiment [Ref. 8] was prepared jointly with Professor Gordon J. F. MacDonald of UCLA, and was presented to the NASA Office of Space Sciences in a meeting on October 29, 1965. The proposal is outlined briefly in Sec. II-A. This proposal represents the culmination of continuing discussions and planning between Stanford University and UCLA which began in 1964. In preparation for the aeronomy

experiment and the relativity experiments that are to follow, a number of companies have been interviewed as candidates for a Phase 0 study.

During the present report period, the engineering effort on the control system design and its evaluation using an air-cushion vehicle has continued. These results are also outlined in Sec. II, and in greater detail in technical reports which are in preparation.

On November 19, 1965, we took part in a presentation to the NASA Advisory Committee on Astronomy at the Kitt Peak Astronomy Center in Tucson, Arizona. The principal purpose of the presentation was to describe the progress and plans of Professor Fairbank's group in developing a special low-temperature gyro with which to perform the Schiff-Pugh test of general relativity in a satellite. In addition, we described briefly the activities in engineering support of that experiment, and showed a film of air-cushion-vehicle simulation testing of the zero-g satellite. (Professor Lange also described some related Air Force gyro development in the engineering group, which may well be beneficial to the NsG-582 program, but which is not sponsored by it.)

## II. SUMMARY OF PROGRESS DURING REPORT PERIOD

### A. AERONOMY EXPERIMENT SATELLITE

A program to develop and operate drag-free earth satellites in two orbital flights has been proposed formally to the Office of Space Sciences by Stanford University and UCLA in Ref. 8. For each flight there would be two major objectives: (1) to prove out in flight the drag-free, zero-g satellite control system that would be used subsequently in a gyro test of general relativity in a satellite [Ref. 1], and (2) to obtain new and important data about the density of the earth's atmosphere and its dynamic behavior during a solar-maximum period [Ref. 9].

The satellites would be launched from the Pacific Missile Range into a polar orbit by Scout launch vehicles. The orbits would have a perigee of about 130 kilometers near the equator and an apogee of 470 to 1000 kilometers, and would carry sufficient fuel for a drag-free life of about ten days and 150 orbits. During this time, the translational control system would control the satellite to follow a purely gravitational orbit, unaffected by aerodynamic drag or other forces. At the end of the drag-free life of the second satellite (and perhaps also of the first), the proof mass would be caged electrostatically to act as an accelerometer, and the system would gather additional air-drag data for the remainder of its orbital life (about 55 to 200 more orbits).

Translational control will be effected via cold-gas thrusters using state-of-the-art valves. Average thrust must exactly balance the drag on the vehicle, which will be essentially aerodynamic for these experiments. Thrust will be accurately measured continuously, as will relative motion between satellite and proof mass. These measurements, together with tracking data, will lead to a selected global mapping of (accurately inferred) aerodynamic density versus location and time.

These data will have important scientific value because at present our knowledge of the condition existing within the upper atmosphere (above 200 km) is based primarily on deduction from density profiles determined by satellite drag measurement. The density is obtained more

or less directly, but temperature and composition are based on model calculations. Model calculations, in turn, depend heavily on the assumed atmospheric condition at a reference level. By convention, the reference level is taken to be at 120 km. This level is assumed because rocket vapor experiments indicate that somewhere between 110 and 140 km convective mixing gives way to diffusive mixing. A number of studies carried out at UCLA show that the observed density profile can be reproduced by using any of a wide range of conditions at the reference level. These calculations demonstrate quantitatively that the satellite drag data at altitudes above 200 km alone cannot provide information useful in determining atmospheric composition and temperature in the region of 100-200 km. In this region, conditions change most rapidly and, in a very real sense, the structure of the entire upper atmosphere depends in a very sensitive way upon the temperature and composition of the atmosphere between 100-200 km.

The region between 100-200 km has been probed by a number of rockets. The rockets yield information regarding instantaneous composition and sometimes density at a particular point within the atmosphere. A large variation in important parameters has been observed. For example, the number density of atomic oxygen deduced from rocket observation at 120 km varies by at least a factor of four. It is not clear whether this variation is due to spatial or temporal inhomogeneity within the atmosphere. Thus, it is extremely important to determine the behavior of the atmosphere within the region of 100-200 km. Only by direct observation over extended periods of time will it be possible to determine whether the heat introduced into the atmosphere by the absorption of ultraviolet radiation is convected, conducted, or radiated throughout our atmosphere. Furthermore, these direct observations will elucidate whether or not photochemical association is coupled with diffusion, an important process in determining the structure of the upper atmosphere. The determination of density at 130 km to 150 km, combined with rocket observation of the chemical composition, can yield data that will permit extending the description to this most important portion of the atmosphere.

Careful and rather comprehensive feasibility studies have been made of vehicle and orbit combinations to maximize the recovery of crucial aeronomical data. The vehicle selected, Fig. 1, has a diameter of  $27\frac{1}{2}$  inches and weighs 300 pounds, including 75 pounds of nitrogen plus freon for drag-compensating thrusting. The orbital missions selected are described in more detail in Ref. 8, where vehicle and orbit-parameter alternatives are considered, together with the results of trade-off studies.

The aeronomy mission requires a thrust-sensing system having an accuracy of one percent and a high frequency response so that details of the thrust profile will not be omitted. A primary design requirement has been to achieve this with off-the-shelf, flight-proven valves. Our solution is to mount a light-weight nozzle with a precision force-rebalance system so that measurement of the restoring force will indicate thrust directly.

We have been studying carefully the development of a low-g electrostatic accelerometer system with the Honeywell Company, in connection with a program of basic inertial instrument research at Stanford University sponsored by the United States Air Force. We are developing a method of three-axis laboratory simulation of the low-g environment for such an instrument, and contemplate a possible flight-test program at a later time. Honeywell has prepared a task, cost, and delivery proposal for such an instrument which we are studying at this time. The instrument is a modification of the existing electrostatic gyro to permit (1) operation at low support force levels and larger gaps, and (2) measurement of suspension voltage to indicate acceleration over a dynamic range of  $10^3$ . Details are given in Ref. 8. The background of this Air Force program has, of course, contributed heavily to our design of an accelerometer mode for the aeronomy satellite. (It should be noted that this program is separate from Honeywell's own electrostatic accelerometer development. That development could help the program proposed here at a later date.)

In preparation for a Phase 0 study of the aeronomy satellite program, we have interviewed a number of companies that we feel collectively

SATELLITE DIAMETER 27.5-IN.

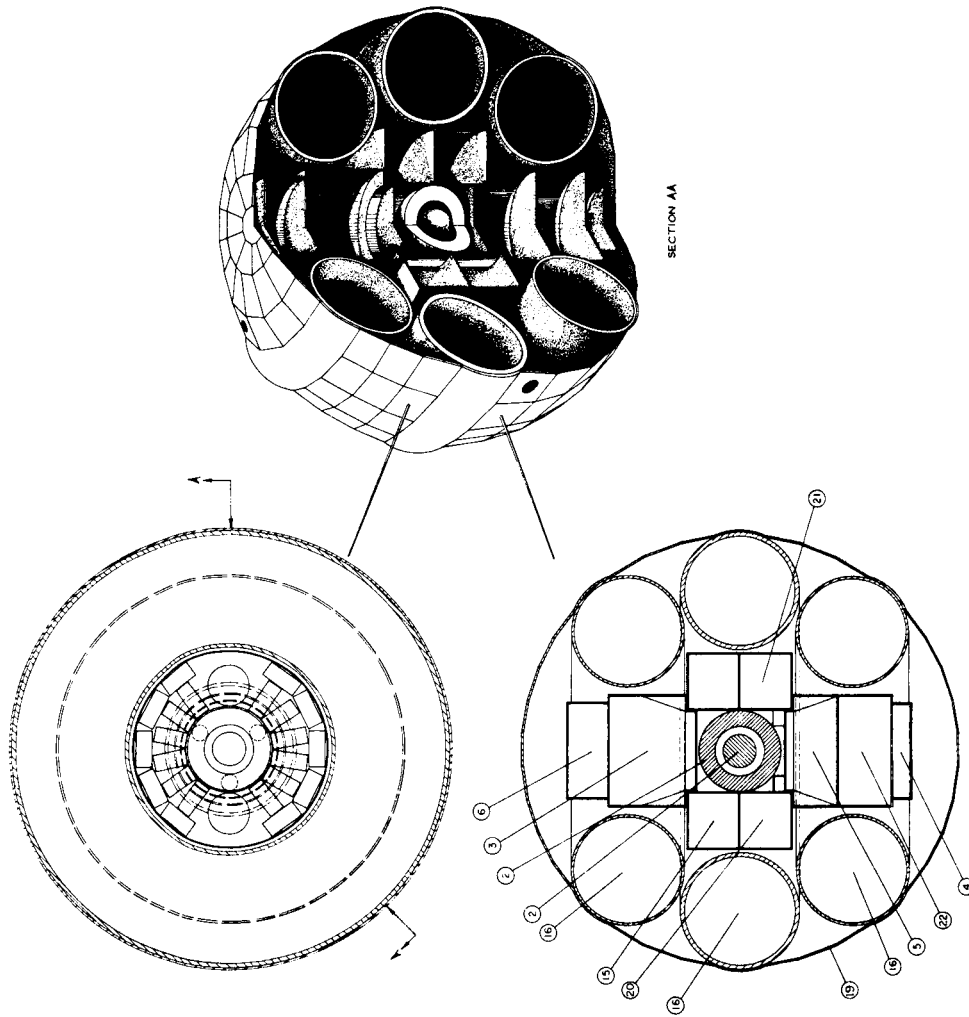

EQUIPMENT	WEIGHT (lb.)	MAXIMUM POWER (watts)
1. STRUCTURE	18	
2. BALL AND PICKUP	4	
3. TELEMETRY (EXCEPT XMITTERS)	6	8
TELEMETRY TRANSMITTERS (2)	2.5	20
4. C. W. BEACON	2	1.0
5. ACCELEROMETER & CONTROL ELEC	7	2.5(control) 6.0(accel)
6. COMMAND REC AND DECODER	4	.35
7. WOBBLE DAMPER	3	
8. COUPLER	1	
9. ANTENNAS	1	
10. BALLAST	4	
11. EARTH SENSORS	2	.2
12. SUN ASPECT SENSORS	2	.2
13. PROPULSION HARDWARE	2.5	
14. THERMAL MATERIAL	1	
15. BATTERIES	11.5	
16. TOROIDAL TANKS	110	
17. HARNESS AND MISC.	5	
18. SOLAR CELLS	7	
19. SOLAR CELL FRAME	10	
20. ORBIT CLOCK AND PROGRAMMER	6	1.0
21. POWER CONTROL UNIT	5	1.0
22. TAPE RECORDER	4.5	2.0
23. PROP JETS & THRUST MEAS SYS	6.0	10.0*
TOTAL (EMPTY WT)	225.0	46.25(control) 49.75(accel)

NITROGEN WT. 52.9

\* Total usage limited to 20 watt hours due to propellant exhaustion

FIG. 1. PROPOSED AERONOMY SATELLITE CONFIGURATION



represent a thorough cross section of satellite technology and flight experience. [REDACTED]

[REDACTED] We have benefited from our discussions with the companies and have been encouraged by their interest and enthusiasm in our program. The exchange of ideas and information has occurred through visits by the company representatives to Stanford or through our visits to the company's facilities. The familiarity gained by these discussions will enhance and expedite our working with the companies chosen for the Phase 0 studies.

#### B. CONTROL SYSTEM ANALYSIS

Robert Farquhar has completed a comparative study (using the two TR-48 analog computers in the slaved mode) of the limit-cycle fuel consumption of a symmetrical drag-free satellite which is spinning about its axis of maximum inertia. Two control mechanizations, a bang-bang system with dead zone and hysteresis and a pulse-width, pulse-frequency modulated system (similar to the one used on the Agena pneumatic attitude control system), were compared, both with and without measurement noise in the relative-position sensor.

In addition, William R. Davis has completed a digital study of the limit-cycle fuel consumption of an arbitrarily tumbling drag-free satellite. Again, two control mechanizations, bang-bang with dead zone and hysteresis and the derived-rate system developed by JPL for the Mariner attitude control system, were compared, both with and without measurement noise in the position sensor.

The results of these two studies indicate that the pulse-width, pulse-frequency modulated system probably represents the best translation-control mechanization for the drag-free satellite. However, these studies have raised a number of new questions which will be the subject

of future analytical investigations. Farquhar's analytical findings are being written into a final report which will appear shortly, and the results of Davis' work will be included in his Ph.D. thesis.

The following is a brief summary of Farquhar's results: Figure 2 shows the geometry for the equations of motion of the spinning drag-free satellite. The unprimed axis set is fixed in the satellite while the primed set is chosen with the  $x$  axis parallel to the component of the drag vector which is in the  $x$ - $y$  plane of the satellite, and with the  $z$  axis parallel to the satellite spin vector. The unprimed reference frame slowly rotates due to the satellite's orbital motion, but this rate is sufficiently slow (compared to the translation-control dynamics) that it may be taken to be an inertial reference.

Figure 3 shows a simplified block diagram of the vehicle and control system dynamics. The signals,  $x$  and  $y$ , which indicate the relative position between the proof mass and the satellite cavity together with the measurement noise (simulated by two EAI Model 201 A's) are fed through lead-lag filters to the control system. The angular rate gain,  $\omega$ , which could be precommanded in a system whose spin rate was relatively constant, multiplies the  $x$  and  $y$  signals and provides additional rate information. A disabling switch was provided to measure the effect of not including the angular-rate terms in the mechanization.

Figures 4 and 5 show block diagrams of the control command system. The bang-bang system includes a dead zone,  $\xi$ , in order to prevent excessive fuel consumption due to two-sided limit cycles. (See Ref. 6 and also Farquhar's report, Ref. 10.) There is a trade-off in dead-zone size between fuel consumption and the accuracy with which the proof mass is centered. The hysteresis,  $\delta$ , is necessary in order to obtain small control impulses and hence small rates so that the system phase point spends the maximum amount of time in the dead zone.

The pulse-width, pulse-frequency system was developed in its present form for the attitude control system of the Agena spacecraft in order to obtain good dead-beat response combined with low limit-cycle fuel consumption, and these characteristics are also present in the drag-free satellite translation control system. The basic circuit, which is

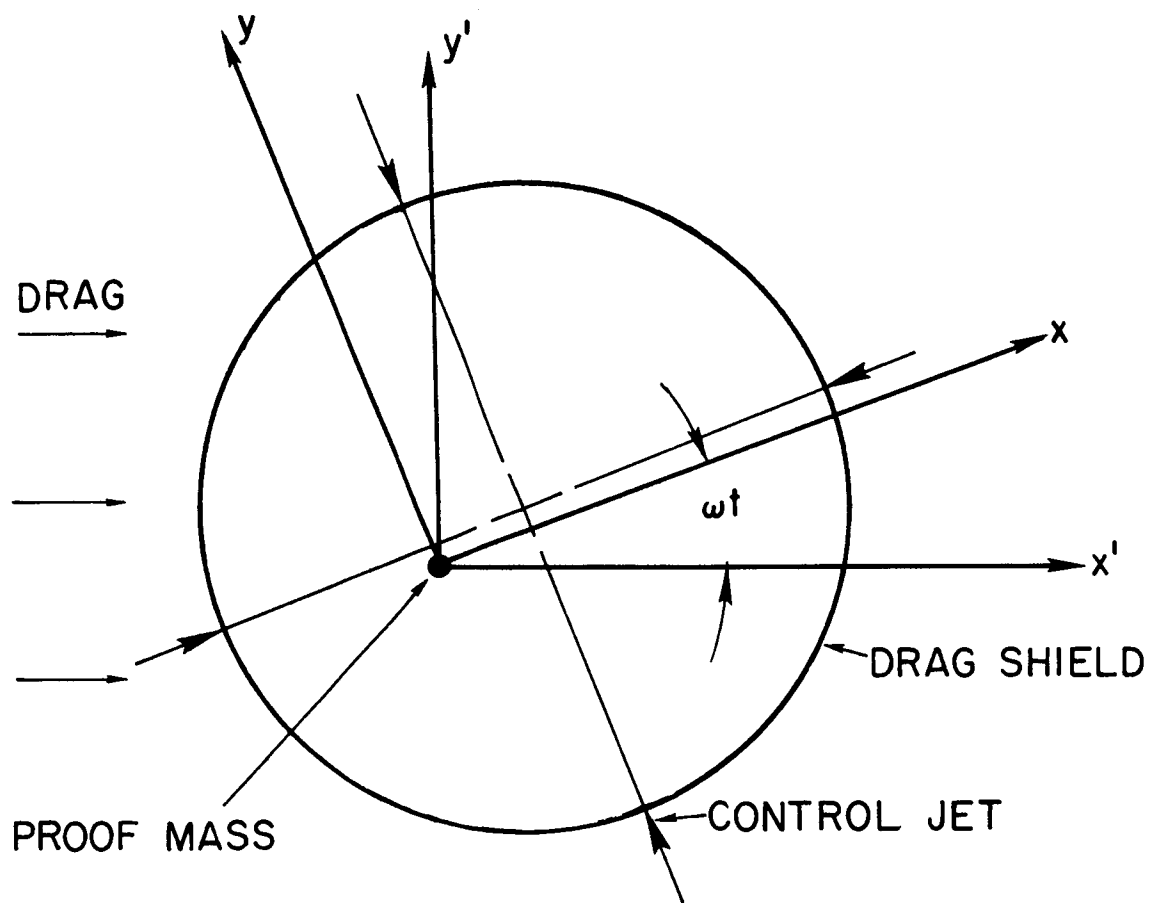

FIG. 2. SPINNING DRAG-FREE SATELLITE

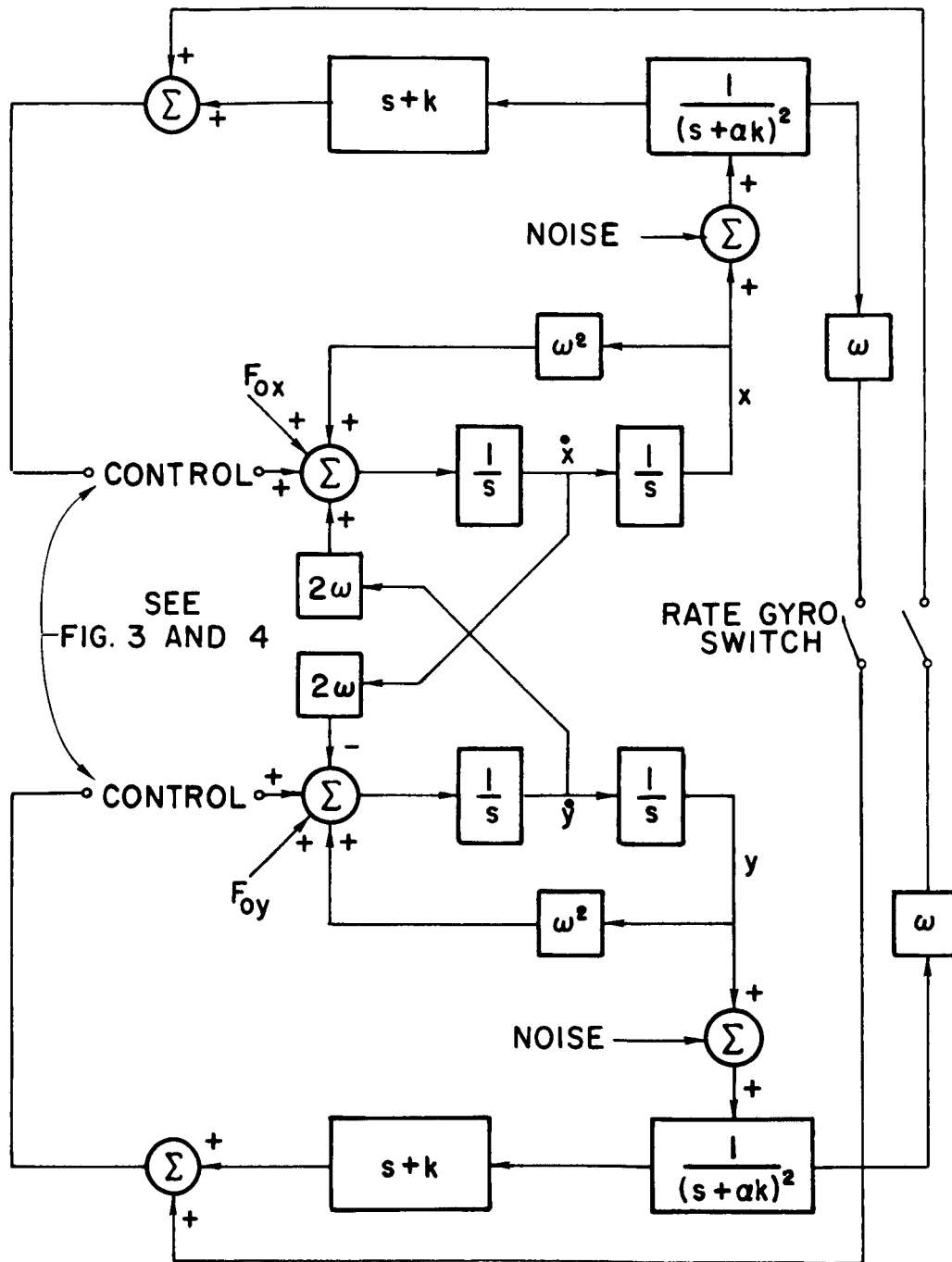

FIG. 3. BLOCK DIAGRAM OF CONTROL SIMULATION

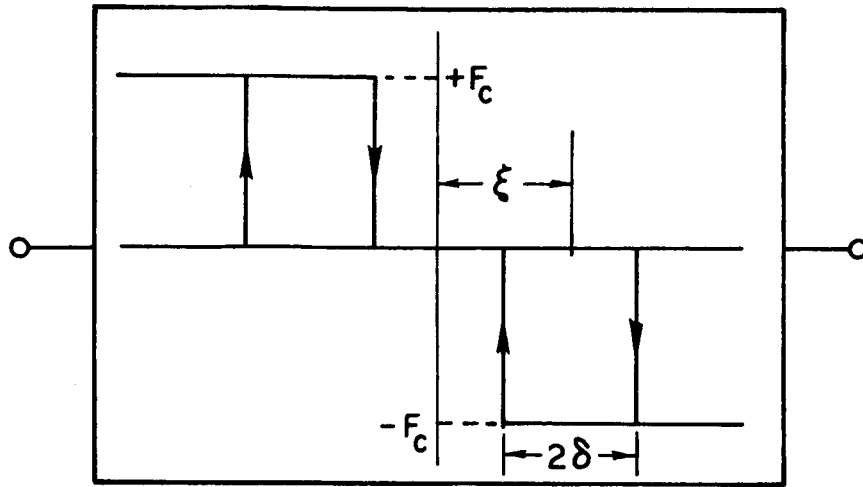

FIG. 4. STRICTLY ON-OFF CONTROL

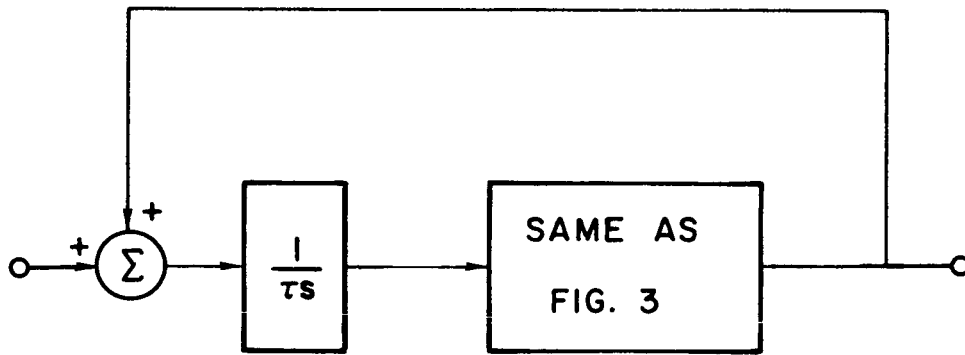

FIG. 5. PULSE-WIDTH, PULSE-FREQUENCY CONTROL

shown in Fig. 5, consists of an integrator followed by a Schmidt trigger (which provides the dead-zone and hysteresis characteristics shown in Fig. 5). The output of the Schmidt trigger is fed back into the integrator. This circuit provides a train of rectangular pulses at its output. The pulse-width and pulse-frequency both vary with input in such a way that the average value of the output is a linear function of the input until the input becomes large enough that saturation occurs. Thus it serves in effect as a modulator for the control jets.

#### 1. Analog-Computer Simulation Results

Figure 6 shows photographs of the two EAI TR-48 analog computers which were used in Farquhar's study. They have the special feature that one computer may be slowed to follow the commands of the second. This was necessary because the number of amplifiers necessary to solve the problem exceeds 48.

Preliminary runs of the analog simulation were used to determine nominal values for the variable parameters. The control parameters were varied, one at a time, about the nominal case and their effect on the fuel-consumption rate was recorded. Four different cases were observed for every parameter variation. Detailed results of these studies are given in Ref. 10.

The analog simulation showed that the pulse-width, pulse-frequency control system has superior noise rejection characteristics in comparison to strictly on-off control. In addition, the P.W.P.F. system is more economical even without noise inputs.

Since only small differences were noted when the rate-gyro switch was open, this portion of the control could be removed to simplify the system. However, this change is only warranted when the angular rates are sufficiently small.

The simulation has also shown that both control systems automatically commutate the jets fixed on the rotating vehicle so that they fire to oppose the drag force, except that there is a small control component perpendicular to the drag direction which stabilizes the cross-axis motion. Furthermore, the control systems accomplish this

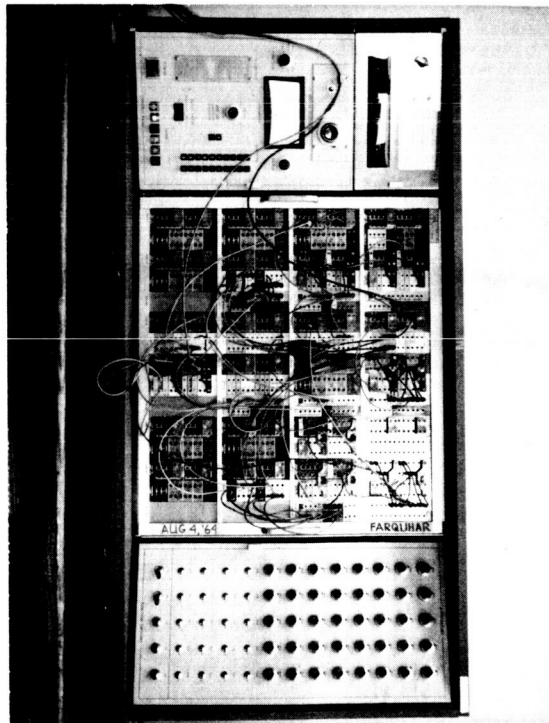
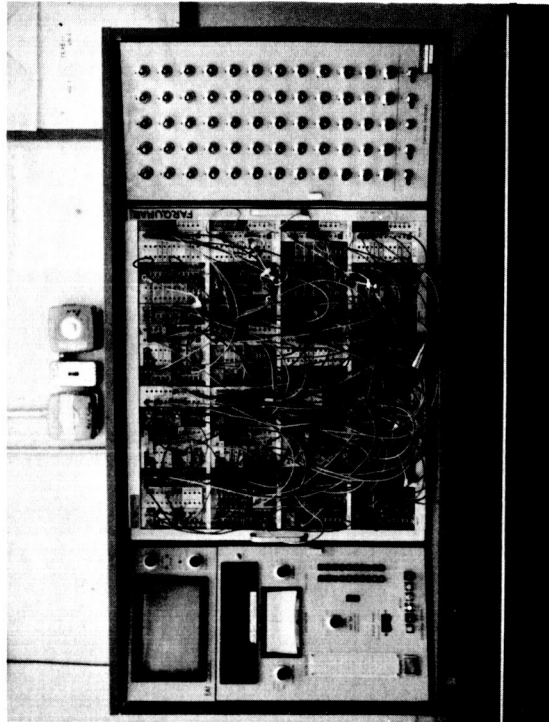

FIG. 6. SPINNING DRAG-FREE SATELLITE ANALOG COMPUTER SIMULATION

commutation without requiring measurements of the magnitude or direction of the drag force.

## 2. Digital-Computer Simulation Results

The results of William R. Davis' analysis of the arbitrarily tumbling drag-free satellite on the B-5500 digital computer are qualitatively similar to Farquhar's.

There are, however, enough differences so that it will be necessary to do some additional analysis before a direct comparison can be made. The JPL derived-rate control system was much less sensitive to noise and consumed less fuel than the bang-bang system, although its convergence in the large or dead-beat response was somewhat slower. Davis has shown conclusively, however, that it is possible to cause an arbitrarily tumbling drag-free satellite to chase the proof mass even though the control system is of the highly nonlinear on-off type, and even though there is noise on the relative-position measurements. Furthermore, this translation control can be accomplished by measuring only the three relative positions  $x$ ,  $y$ , and  $z$ , without any knowledge of the vehicle attitude. There is one drawback, however, in the arbitrarily tumbling case: The body angular rates  $\omega_x$ ,  $\omega_y$ , and  $\omega_z$  must be obtained from rate gyros, since, for an arbitrary body, these rates are rapidly changing functions of time so that the gains cannot be commanded from the ground, as they can in the case of a symmetric satellite spinning about its maximum-inertia axis. As in the symmetric case, if the angular rates are not excessive, then the angular-rate terms may be omitted in the mechanization with little or no degradation in performance.

## 3. Basic Theoretical Studies

The studies by Farquhar and Davis of limit cycle fuel consumption in the presence of measurement noise by analog or digital simulation is basically a problem in the field of stochastic differential equations. There are a number of basic difficulties of both a practical and a



theoretical nature associated with determining the response of a nonlinear system to a random process. As part of his doctoral research Don McNeal has investigated some of these problems.

There are two basic approaches which can be used to determine the statistical properties of the output of a nonlinear system whose input is a "white" random process. (The input can be assumed to be "white" since any stationary random process can be generated by passing "white" noise through an appropriate linear filter. Hence, if the input to the nonlinear system is not "white," then the corresponding linear system can be augmented to the nonlinear system and the input to the combined system will be "white.") The first approach is to linearize the nonlinear equations about a nominal trajectory. The covariance matrix of the output is then the solution of a time-varying, deterministic, matrix differential equation which can be easily solved on a digital computer. If the input process is Gaussian, then the output of the linearized system is also Gaussian and is completely specified by its covariance matrix. If the input is not Gaussian, the covariance matrix does not completely specify the statistical properties of the output but does give an estimate of the output dispersion. This is generally sufficient for engineering purposes.

The problem with linearization is the necessary assumption that the difference between the disturbed trajectory and the nominal trajectory is small. In many problems, of course, this is not a valid assumption. It is then necessary to resort to direct numerical integration of the nonlinear, stochastic differential equation. This is the second technique mentioned previously.

Numerical integration of stochastic differential equations presents certain difficulties which do not appear in the integration of deterministic differential equations. For example, the usual error analyses made for Adams or Runge-Kutta methods do not apply to stochastic equations because of the nonanalytic nature of the input process. It has also been shown by McNeal and Duncan that some of the standard library integration packages yield incorrect statistical information even when the stochastic equations are linear. While this result is

not completely understood, it is certainly connected with the problem of approximating a continuous random process with a sequence of random variables, since this is what the computer must do. Future analytical studies will be directed toward the specification of an integration method which will integrate stochastic differential equations satisfactorily.

Alan Fleming has investigated the asymptotic stability of the state-space origin for simplified models of the body-fixed, on-off control of both the translation and the attitude for an axially symmetrical spinning drag-free satellite. Although it has been shown previously by analog-computer simulations that the on-off control laws used for these two systems can be expected to be asymptotically stable, until recently an analytical demonstration of this stability could not be produced. (See Refs. 11 and 12.)

Fleming has been able to obtain Lyapunov functions for these systems and has shown that:

1. Both the two- and three-dimensional translational control systems are asymptotically stable at the origin for initial state conditions within a certain spherical region of the origin. The size of the sphere is directly proportional to the force magnitude of the on-off thrusters and inversely proportional to the ratio of the position and velocity gains (as seen in an inertial frame) of the on-off controller input.
2. The attitude control of an axially symmetric spinning body causes the state-space origin to be asymptotically stable in the large for a closed set of values for the switching surface orientations in state space.

It should be noted that the Lyapunov functions mentioned above define only sufficient conditions for stability, and that the true stability conditions are less restrictive.

Lt. Col. Robert D. Smith and Professor Lange have developed a technique for computing the effects of the force error (see Ref. 13) on the drag-free satellite trajectory for orbits of arbitrary eccentricity. Methods based on linearizing around circular orbits suffer from the

defect that the neglected nonlinear terms give rise to long-term secular components which can be significant over time periods of the order of one year. The analysis of Lange and Smith is based on the theory of Floquet and does not suffer from this defect. A paper on this result [Ref. 12] was presented at the XVI Congress of the IAF and will be published in the proceedings of that meeting. William R. Davis has extended the work of Lange and Smith using the theory of symplectic matrices. Davis' results reduce the labor of computing the inverse of the system state-transition matrix. This inverse is required in the perturbation calculations. This material is being published as an AIAA technical note and will be included in Davis' doctoral thesis.

#### C. RESEARCH ON AIR-CUSHION VEHICLE BEHAVIOR

The work done theoretically and experimentally on the support dynamics of the air-cushion-vehicle simulator, during preceding report periods, has been summarized in Ref. 4, Sec. II-A 2, and is described in detail in a report on simulator development which is under preparation.

During the present report period, further, more basic flow investigations have been completed by Mr. Rehsteiner, to provide a comprehensive understanding of such devices for use in the future. As it happens, the simulator vehicle itself is not well suited for such basic investigations because of its lack of flexibility, its size and weight, and because it was not possible to determine the exact shape of its bottom surface without a great deal of effort. Therefore, a new special flow-research vehicle has been designed and built. It uses a 12 inch diameter base plate (as compared to 28 inch diameter for the simulator vehicle) and is highly versatile. Three different base plates have been made to study the effect of axisymmetrically distorted surfaces: a flat, a concave, and a convex one. The curved surfaces are spherical with a radius of curvature of approximately 300 ft. Static tests performed so far with this new vehicle have shown complete agreement between the measured data and the "compressible" theory. In addition, with the convex base plate, dynamic instability has occurred for the first time in the form of strong vertical vibrations of the whole vehicle. An

existing theory gives qualitative , but no good quantitative agreement with the observations.

It seems also that there are two basically different situations which contribute to "dynamic instability"; (1) when the thickness of the supporting gas film increases from the inlet of the gas to the exhaust edge, and (2) whenever the "lubricant" of the hydrostatic bearing is compressible. Future flow research effort will concentrate mainly on these stability problems.

The study of the nonaxisymmetrically distorted plate is mathematically tedious and does not seem to lead to very interesting results.

In addition to the research in support of the air-cushion vehicle for simulating the translation control system of a drag-free satellite, a spherical gas bearing has been designed. It will be used as a simulator for the spinning vehicle control system discussed in Part B. This spherical gas bearing will have its axis of symmetry inclined by approximately  $50^\circ$  with respect to the vertical. Previous gas bearing tables have been designed for nonspinning vehicles. The new spherical air bearing will have two viscous-flow regimes: one for the axial and a second for the radial component of the support force.

#### D. EXPERIMENTAL SATELLITE CONTROL SYSTEM SIMULATION

A drag-free satellite has been simulated in the laboratory using an air-cushion vehicle. The first air-cushion vehicle was described in Ref. 3 and its development and improvements were described in Ref. 4. The vehicle is supported on an air film over a granite table. The granite table is tilted to permit simulation of the perturbing accelerations to the drag and other forces in orbit in the two horizontal directions. A feedback control system on the vehicle senses the position of the vehicle with respect to a fixed sphere, representing the orbiting proof mass, and corrects the vehicle position by actuating pneumatic reaction jets. Thus, in two axes, the simulator operates in precisely the same manner as the drag-free satellite. In early tests, the limitations were the degree to which the granite table could be leveled and kept clean. This limitation was removed with the use of an automatic

table-leveling system and a controlled environment room. With the level sensor housed in an oven controlled to 0.001 deg. F, short-term accuracies and resolution exceeding 0.1 arc sec have been achieved, and stability for periods of twelve hours in the range of 0.2 to 0.5 arc sec have been typical.

As in many high-precision development programs, improvements in one area bring to light limitations in another. The limitations in simulator performance accuracy are now asymmetries and uncertainties in the lateral force produced by the support flow. One of the principal causes of this is the irregularities in the base plate of the existing air-cushion vehicle--a condition which will be corrected by the second-generation air-cushion vehicle.

Three months of concentrated effort were made to improve this situation using precision adjustment of the mass center and of the capacitive pickoff location, but uncertainties equivalent to approximately one arc sec remain, due to these forces. Some of these forces are body fixed but depend upon the vehicle orientation with respect to the table, and hence arise, apparently, from a combination of the surface figure of the table and of the base plate. Details of this work are given in a report on the air-cushion vehicle which is under preparation. This work is aided by the continuing fundamental research on the nature of the support flow, as outlined in Part C.

A rate gyro, which was received last spring, was mounted on the existing air-cushion vehicle when it became apparent that the equipment would be delayed for the second-generation vehicle. It has been used to verify successfully the analysis and analog-computer studies that have been completed for a tumbling vehicle. The gyro, which was damaged during the summer, has been repaired and will now be mounted on the second-generation air-cushion vehicle.

During the spring and early summer, the mechanization of several control systems was completed for use on the simulator. Tests were run to compare the noise sensitivity and gas-consumption economy of a bang-bang, rate-circuit-controlled system, as compared with a system using a rate circuit and a pulse-width pulse-frequency thrust modulator.

The qualitative results were immediately startling. The presence of noise in the system makes the bang-bang system highly irregular when compared with the pulse-width pulse-frequency system. Both systems operated satisfactorily, but the quantitative differences clearly favored the pulse-width pulse-frequency mechanization. Quantitative results for the higher altitudes, corresponding to those we would choose for the relativity experiment, will have to await the completion of the second-generation air-cushion vehicle. When these tests are performed, a derived-rate system will also be mechanized as a third candidate system.

#### E. SECOND-GENERATION AIR-CUSHION VEHICLE

A preliminary design of the second-generation air-cushion vehicle was completed in the fall of 1964. To make the simulation as realistic and meaningful as possible, it was decided to use flight hardware to the largest extent possible. Because of the high cost involved in obtaining new flight hardware, it was decided to approach the Jet Propulsion Laboratory to see if surplus pneumatic hardware might be available. They were extremely enthusiastic in wanting to support us and by the spring of 1965 they had gathered a variety of pneumatic hardware, surplus to their needs, of the type required for the simulator. Due to administrative difficulties in transferring such equipment, a delay was experienced and the pneumatic parts did not arrive until late November 1965. The status of the second-generation air-cushion vehicle is therefore unchanged since the last status report.

## REFERENCES

1. Proposal To Develop a Zero-g, Drag-Free Satellite and To Perform a Gyro Test of General Relativity in a Satellite, submitted to NASA by Stanford University, Nov 1962.
2. First Semiannual Status Report on the Engineering Portion of a Research Program To Develop a Zero-g, Drag-Free Satellite and To Perform a Test of General Relativity in a Satellite, May 1964.
3. Second Semiannual Status Report on the Engineering Portion of a Research Program To Develop a Zero-g, Drag-Free Satellite and To Perform a Test of General Relativity in a Satellite, Nov 1964.
4. Third Semiannual Status Report on the Engineering Portion of a Research Program To Develop a Zero-g, Drag-Free Satellite and To Perform a Test of General Relativity in a Satellite, May 1965.
5. B. O. Lange, "The Control and Use of Drag-Free Satellites," Ph.D. Dissertation, Department of Electrical Engineering, Stanford University, Stanford, Calif., Jun 1964.
6. B. O. Lange, "The Drag-Free Satellite," AIAA J., vol. 2, no. 9, Sep 1964, pp. 1590-1606.
7. B. O. Lange, "The Unsupported Gyroscope," Unconventional Inertial Sensors Meeting, Republic Aviation, Farmingdale, L. I., Nov 1964.
8. Proposal To Develop and Operate a Sustaining Earth Satellite in Two Orbital Flights, submitted to NASA by Stanford University and the University of California at Los Angeles, Oct 1965.
9. Proposal for Phase I Studies of the Sustaining Orbiting Geophysical Observatory," vol. I, Scientific/Technical, submitted to NASA by the University of California at Los Angeles, Institute of Geophysical and Planetary Physics Space Center, Dec 1962.
10. R. W. Farquhar, "Analog Studies of the Limit Cycle Fuel Consumption of a Spinning Symmetric, Drag-Free Satellite," Department of Aeronautics and Astronautics, SUDAER Rept. in preparation.
11. B. O. Lange and A. W. Fleming, "The Control of Linear Constant Dynamical Systems Which Are 'Frequency Symmetric' but Not 'Complex Symmetric'," submitted to the 1966 IFAC.
12. B. O. Lange, A. W. Fleming, and B. W. Parkinson, "Control Synthesis for Spinning Aerospace Vehicles Via the Property of 'Frequency Symmetry'," submitted to the XVI International Astronautical Congress, Athens, Greece.

13. B. O. Lange and R. G. Smith, "The Application of Floquet Theory to the Computation of Small Orbital Perturbations Over Long Time Intervals Using the Tschauner-Hempel Equations," SUDAER Rept. No. 241, Department of Aeronautics and Astronautics, Stanford University, Stanford, Calif., Aug 1965.