

FACILITY F-1431 602

**N66-23625**

480

CR-74379

(THRU) \_\_\_\_\_

1

(CODE) \_\_\_\_\_

31

(CATEGORY) \_\_\_\_\_

GPO PRICE \$ \_\_\_\_\_

CFSTI PRICE(S) \$ \_\_\_\_\_

Hard copy (HC) 7.80

Microfiche (MF) 2.25

ff 653 July 65

**GENERAL DYNAMICS**  
Fort Worth Division

FZM-4492-II  
28 February 1966  
Volume II

TECHNICAL REPORT: DESIGN  
OF IN-FLIGHT EXPERIMENTS

SATURN IN-FLIGHT EXPERIMENTAL  
PAYLOAD STUDY

CONTRACT NAS8-20236

Prepared for the

GEORGE C. MARSHALL SPACE FLIGHT CENTER  
NATIONAL AERONAUTICS AND SPACE ADMINISTRATION  
HUNTSVILLE, ALABAMA

APPROVED

  
\_\_\_\_\_  
Dr. T. S. Webb  
Program Manager  
Advanced Missile and  
Space Systems

APPROVED

  
\_\_\_\_\_  
Dr. R. N. Austin  
Project Manager

APPROVED

  
\_\_\_\_\_  
C. D. Brooks, Jr.  
Study Leader

GENERAL DYNAMICS  
FORT WORTH DIVISION

## F O R E W O R D

This document is Volume II of the report on the Saturn In-Flight Experimental Payload Study. It contains that portion of the Technical Report pertaining to the Design of In-Flight Experiments. The study was conducted by the Fort Worth Division of General Dynamics for the George C. Marshall Space Flight Center of the National Aeronautics and Space Administration under Contract NAS8-20236. The study was established by the Advanced Systems Office of NASA-MSFC as part of an effort to provide for the orderly and economic utilization of space vehicle hardware in the tasks devoted to the accumulation of scientific data.

The complete results of this study are contained in the following volumes:

- Volume I - Summary
- Volume II - Technical Report: Design of In-Flight Experiments
- Volume III - Technical Report: Computer Program Development and Methodology
- Volume IV - Utilization Instructions.

This study was performed during the period beginning July 1965 and ending February 1966. The general guidelines of the study were set forth by NASA-MSFC in RFQ DCN 1-5-23-00009-01 and RFQ DCN 1-5-23-00010-01, and the Fort Worth Division has based the study effort on these guidelines in order to obtain the results described herein.

## A C K N O W L E D G M E N T S

The technical direction and assistance of W. H. Stafford, Study Technical Supervisor, NASA-MSFC-ASO, is gratefully acknowledged. The following personnel at the Fort Worth Division of General Dynamics have made significant technical contributions to this report:

R. N. Austin	Project Manager
C. D. Brooks	Study Leader
M. K. Fox	Leadman - Mission Definition, Analytical Representations, Computer Program Development
W. J. Ritts	Leadman - Experiment Package Ancillary Systems
J. S. Barron	Leadman - In-Flight Experiment Location Definitions and Analytical Representations
V. A. Lee	Technical Consultant
T. P. Robinson	Scientific and Technological Experiment Consultant
W. H. Steurer	Scientific and Technological Experiment Consultant
G. E. Hinds	Scientific and Technological Experiment Consultant
J. A. Regalbuto	Scientific and Technological Experiment Consultant
F. E. Van Nostran	Scientific and Technological Experiment Consultant
J. C. Redmond	Scientific and Technological Experiment Consultant
J. S. Turner	Power Supply System Analysis
B. W. Alexander	Communications System Analysis
C. D. Campbell	Data Automation System Analysis
G. P. Breaux	Attitude Control System Analysis
J. D. Anderson	Mechanical Environment/Compatibility Analysis
D. G. Barry	Thermal Environment/Compatibility Analysis
R. A. Knezek	Thermal Environment/Compatibility Analysis
B. J. Wallace	Electromagnetic Environment/Compatibility Analysis
G. F. Gibson	In-Flight Experiment Package Configuration Design
B. J. Csaszar	In-Flight Experiment Package Configuration Design
L. E. Heyduck	Saturn IB/Apollo Structural Analysis
C. M. Blackmon	Saturn IB/Apollo Structural Analysis
D. W. Jones	In-Flight Experiment Effectiveness Analysis
H. F. Hefley	In-Flight Experiment Effectiveness Analysis
W. J. Moran	Computer Program Development and Methodology
K. A. Pinter	Mission Characteristics, Support Program Development
J. A. McCabe	Experiment Package Propulsion System Selection and Sizing
R. J. Allen	Reliability Analysis
D. G. Samson	Cost Analysis
H. R. Darby	Development Schedule Analysis
R. L. Macy	Development Schedule Analysis
E. G. Brooker	Development Schedule Analysis
W. J. Rowley	Computer Program Systems Compatibility

T A B L E   O F   C O N T E N T S

V O L U M E   I I

T E C H N I C A L   R E P O R T :   D E S I G N   O F

I N - F L I G H T   E X P E R I M E N T S

	<u>Page</u>
1.0 INTRODUCTION	1
1.1 General	1
1.2 Approach	1
1.3 Computer Program - SEPTER	2
1.4 Program Plan	3
1.5 Guidelines and Ground Rules	4
1.6 Summary of Major Study Accomplishments	5
 PART I: DESIGN OF SELECTED IN-FLIGHT EXPERIMENTS	 9
2.0 APPROACH TO DESIGN OF IN-FLIGHT EXPERIMENTS	11
3.0 DEFINITION OF EXPERIMENTS	15
3.1 Selection of a Representative Sample of Potentially Applicable Experiments	15
3.1.1 Systems Development and Test	15
3.1.2 Materials and Structures	16
3.1.3 Multispectral Imagery of the Earth and Orbiting Objects	16
3.1.4 Solid/Liquid/Gas Behavior	17
3.1.5 Microorganisms	18
3.1.6 Observations of the Earth's Atmosphere, the Space Environment, and Astronomical Phenomena	19
3.2 Relationship to NASA Scientific/Technical Areas	19
3.3 Summary of Selected Experiments and Their Requirements	21

TABLE OF CONTENTS (Cont'd)

	<u>Page</u>	
4.0	DEFINITION OF ANCILLARY SYSTEMS	23
4.1	General	23
4.2	Attitude Control	23
4.3	Data Automation	25
4.4	Communications	27
4.5	Electric Power	28
4.6	Thermal Control	32
4.7	Ancillary Systems Mass Summary	34
5.0	EXPERIMENT ENVIRONMENTAL REQUIREMENTS	35
5.1	General	35
5.2	Thermal	36
5.3	Vibration	37
5.4	Acoustics	39
5.5	Electromagnetic	40
6.0	CONCEPTUAL DESIGN OF EXPERIMENTS	43
6.1	General	43
6.2	Experiment Characteristics	45
6.2.1	Deployment Requirements	45
6.2.2	Mass	46
6.2.3	Volume	48
6.3	Configuration Description	48
6.3.1	Category I - Systems Development and Test	50
6.3.2	Category II - Materials and Structures	52
6.3.3	Category III - Multispectral Imagery of the Earth and Orbiting Objects	54
6.3.4	Category IV - Solid/Liquid/Gas Behavior	57
6.3.5	Category V - Microorganisms	60
6.3.6	Category VI - Observations of the Earth's Atmosphere, the Space Environment, and Astronomical Phenomena	62

TABLE OF CONTENTS (Cont'd)

	<u>Page</u>
7.0 RELIABILITY, DEVELOPMENT SCHEDULE, AND COST ANALYSES	67
7.1 Reliability Analysis	67
7.1.1 General	67
7.1.2 Equipment Reliability	67
7.1.3 Reliability Model	67
7.1.4 Individual Experiment Reliability Predictions	69
7.2 Development Schedule Analysis	70
7.3 Cost Analysis	73
PART II: PROGRAM DESIGN	77
8.0 PROGRAM DESIGN METHODOLOGY	79
8.1 General	79
8.2 Input Requirements	79
8.3 Construction and Operation	80
8.4 Program Output	92
PART III: APPENDICES	95
APPENDIX A EXPERIMENT DESCRIPTIONS	97
A.1 Systems Development and Test (SDT)	98
A.2 Materials and Structures (MS)	136
A.3 Multispectral Imagery of the Earth and Orbiting Objects (MI)	178
A.4 Solid/Liquid/Gas Behavior (SLG)	234
A.5 Microorganisms (M)	259
A.6 Observations of the Earth's Atmosphere, the Space Environment, and Astronomical Phenomena (OEA)	286
APPENDIX B EXPERIMENT MASS SUMMARIES	317
APPENDIX C DATA AUTOMATION WORKSHEETS	347
APPENDIX D ATTITUDE CONTROL ASSUMPTIONS	355
APPENDIX E COMMUNICATIONS WORKSHEETS	359

TABLE OF CONTENTS (Cont'd)

	<u>Page</u>
APPENDIX F ELECTRIC POWER WORKSHEETS	389
APPENDIX G THERMAL CONTROL WORKSHEETS	417
LIST OF FIGURES	449
LIST OF TABLES	453



# S E C T I O N 1

## I N T R O D U C T I O N

### 1.1 GENERAL

This document is Volume II of the report on the Saturn In-Flight Experimental Payload Study. It contains that portion of the Technical Report pertaining to Design of In-Flight Experiments. The remaining portion of the Technical Report pertains to Computer Program Development and Methodology and constitutes Volume III. The study was performed by the Fort Worth Division of General Dynamics for the George C. Marshall Space Flight Center.

By the utilization of the secondary payload capability of the Saturn family of launch vehicles, NASA can provide an efficient means for conducting the large number of Earth orbital experiments that has been suggested by the scientific community. Since it is to be assumed that the mission of each launch vehicle is designed to attain specific objectives associated with the primary payload only, it is essential that the in-flight experiments and the launch vehicle be properly mated to provide for efficient utilization of the remaining mass and volume capability of the launch vehicle and for the accomplishment of a high percentage of the experiment data acquisition objectives. Because of the combination of numerous vehicles with varying missions and capabilities and a large number of experiments with varying requirements, the evaluation of the vehicle/experiment mating presents a significant management problem. The basic objective of the Saturn In-Flight Experimental Payload Study is to provide NASA with a management tool in the form of a computer program which can be used to make a rapid evaluation of numerous potentially attractive space experiments that constitute possible secondary in-flight payloads for the Saturn family of launch vehicles.

### 1.2 APPROACH

To attain this overall study objective, two major study tasks were specified: (1) an analysis of the physical characteristics of sensors and associated equipments for use as possible experimental payloads on Saturn-class vehicles and the mission effectiveness values of these experiments as a function of the initial elements and/or mission parameters of the deployed orbit, and (2) the development of a computerized methodology for the technical evaluation and rating of these potential in-flight experimental payloads.

The technical approach used throughout the study is based on the development of Program SEPTER (Saturn Experimental Payload Technical Evaluation and Rating). Two fundamental criteria are employed in Program SEPTER to evaluate the experiments that are being considered for possible inclusion on a Saturn flight: (1) physical compatibility of the experiments with possible locations aboard the vehicle, and (2) experiment/mission effectiveness. The physical compatibility of an experiment package with a vehicle location refers, in this study, not only to mass/volume compatibility but also to compatibility with the thermal, acoustic, vibration, and electromagnetic environments. Experiment/mission effectiveness is defined as the percent of the data acquisition objectives which would be attained by including a particular experiment on a given Saturn flight.

### 1.3 COMPUTER PROGRAM - SEPTER

The overall structure and the key concepts of Program SEPTER are shown in Figure 1-1. This program contains provisions for operating in two basic modes. In the Mode I operation, the compatibility and effectiveness of single experiments are determined. In the Mode II operation, the arrangement configurations and compatibility of multiple experiments are analyzed, and desirable arrangements are determined.

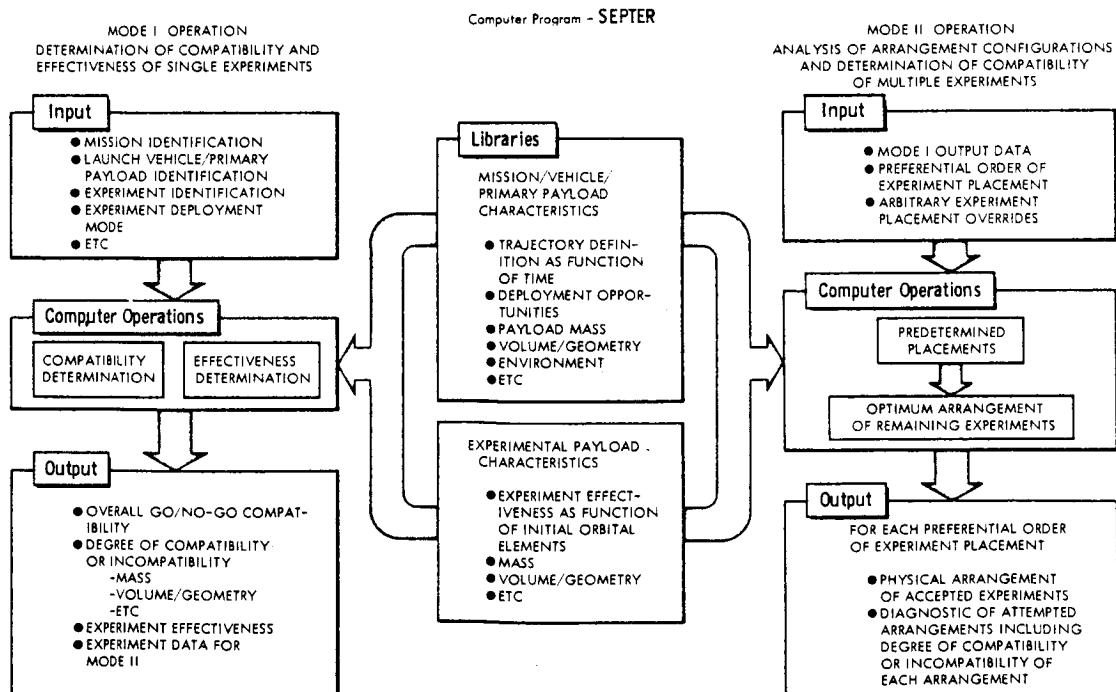

Figure 1-1 SATURN EXPERIMENTAL PAYLOAD TECHNICAL EVALUATION AND RATING

Data used in the single experiment or Mode I analysis consist of mission, launch vehicle/primary payload, and experiment identifications and associated information, such as experiment deployment mode, etc. These identifications will result in selections from the libraries of the mission profile, the potential experimental payload locations aboard the vehicle, and the experiments to be considered in the particular "mission." The program is then used to compare the libraries of mission/vehicle/primary payload characteristics and experiments characteristics with these data and to determine the compatibility and effectiveness of each individual experiment. The Mode I output consists of a listing of the experiments, along with information on their individual overall go/no-go compatibility, degree of compatibility or incompatibility, and effectiveness.

After an examination of Mode I output, NASA management will formulate a preference list which establishes the desired order in which the experiments are to be loaded aboard the vehicle.

The data used in the multiple experiment or Mode II operation consists of a preference list, a compatibility library from Mode I output, problem control data, and library overrides. The Mode II output is in the form of printed results in which the accepted experimental payloads from the preference list and the cavities within which they have been placed according to the predetermined and optimal arrangement analyses are listed.

#### 1.4 PROGRAM PLAN

The basic program plan shown in Figure 1-2 was developed by the Fort Worth Division of General Dynamics to achieve the objectives established for this study. The use of this approach permits (1) an analysis of the physical characteristics and mission sensitivity of experiments of in-flight payloads for Saturn-class vehicles, and (2) the determination of a computer methodology for the technical evaluation and rating of these in-flight experimental payloads. The technical plan is divided into the individual study areas associated with the experiments-related task (Task I) and the computer methodology development task (Task II).

The Task I studies were devoted to (1) a thorough definition of the objectives, data acquisition requirements, and sensors for each of a group of representative experiments, (2) establishment of the physical characteristics of each individual experiment by synthesizing self-contained experiment packages on the basis of sensor requirements, (3) analysis of experiment effectiveness variations as a function of experiment-deployment orbital elements, and (4) computer mechanization of the computation of effectiveness values and physical characteristics.

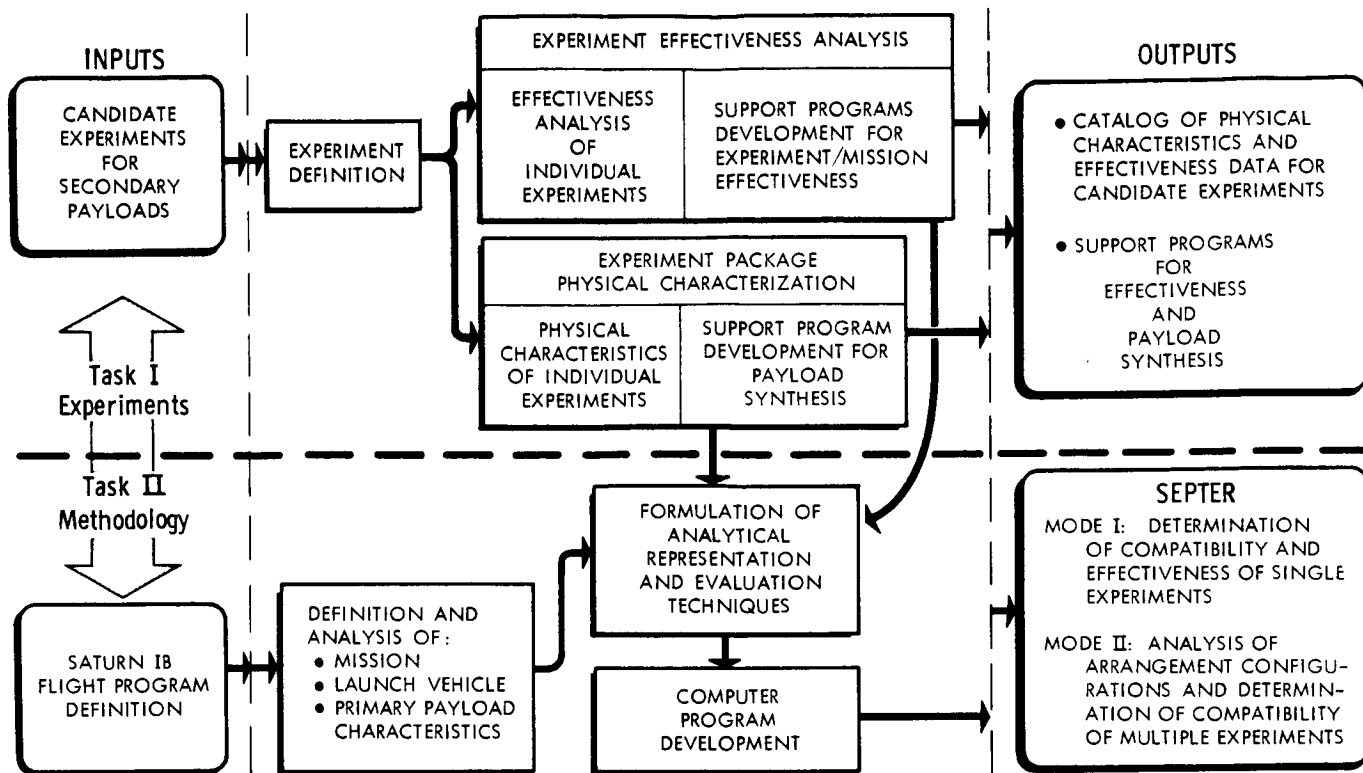

Figure 1-2 BASIC PROGRAM PLAN

The Task II studies were devoted to (1) a definition and analysis of the relevant mission, vehicle, and primary payload characteristics of the vehicle configurations to be considered, (2) development of analytical representations to allow the computer program to evaluate and rate single-experiment compatibility/effectiveness and to analyze multiple arrangement/compatibility, and (3) formulation of the computer program logic, the input and output data requirements and formats, the library data formats, and the options and modes of operation which, when combined with the analytical representations, will yield the operable computer program.

### 1.5 GUIDELINES AND GROUND RULES

A number of guidelines and ground rules were specified at the beginning of the study in order to establish the overall study philosophy and to limit the scope of the experiment and vehicle analyses. The experiments considered in this study constitute secondary payloads in that the missions on which these experiments may be flown have been designed to attain specified objectives associated with the primary payload. For example, the primary missions which were used in the mission characteristics library of the computer program are the Saturn IB/Apollo flight test missions. The basic

Apollo spacecraft (Command Module, Service Module, and Lunar Excursion Module) is the primary payload, and any additional experimental packages carried on these flights would then be secondary payloads. Although other vehicle configurations should eventually be included in the launch vehicle/primary payload characteristics library, the Saturn IB/Apollo - including the Command Module, the Service Modules, and the Lunar Excursion Module - was chosen as the baseline configuration for this study.

The Fort Worth Division of General Dynamics acknowledges the prerogative and responsibility of NASA to define and approve in-flight experiments. However, in order to understand how the computer methodology may be affected by differences in (1) the physical characteristics of experiment packages and vehicle cavity locations, and (2) the requirements for realistic examples of experiment effectiveness, it was necessary for the Fort Worth Division to define a number of potentially attractive in-flight experiments. In establishing configuration designs for these experiment packages, primary emphasis was placed on self-contained packages; that is, consideration was not given to using the support capabilities of on-board equipments or to the possibility of sharing subsystems among experiments. The analysis of physical compatibility was basically performed by considering completely self-contained packages; however, certain vehicle-dependent packages, which are self-contained packages exclusive of power and communications subsystems, were also considered. The experiment packages were designed to assure that they do not in any way interfere with the primary payload. Furthermore, the package designs were based on the assumption that only a minimum of astronaut participation will be allowed, i.e., only to effect off-on switching, film retrieval, etc.

## 1.6 SUMMARY OF MAJOR STUDY ACCOMPLISHMENTS

The major tasks which have been accomplished as a result of this study effort are summarized below.

1. From the list of 85 experiments provided in NASA Experiment Descriptions for Extended Apollo Earth-Orbit Flights, 30 experiments were selected which were representative of the list and were compatible with the study ground rules. The following were accomplished in the case of each of these 30 experiments:
  - a. The physical characteristics of the experiment sensors and the ancillary systems — attitude control, data automation, communications, electric power, and thermal control — were defined.

- b. The thermal, vibration, acoustic, and electromagnetic environmental requirements were established.
  - c. Conceptual design drawings were prepared, and the mass, volume, and geometry of the experiment were determined.
  - d. The deployment requirements were defined.
  - e. Preliminary reliability, development schedule, and cost analyses were performed.
2. The pertinent mission characteristics (trajectory parameters, sequence-of-events, and experimental payload possible deployment modes) of a typical Saturn IB/Apollo Earth-orbital mission were defined and analyzed.
3. A total of 53 cavities (potential payload locations) were identified on the Saturn IB/Apollo vehicle. The following were accomplished in the case of each of the 53 cavities:
  - a. Isometric drawings were prepared showing the cavity shape and volume.
  - b. The mass capacity was determined.
  - c. The thermal, vibration, acoustic, and electromagnetic environments were established.
  - d. The deployment capability was defined.
4. A methodology was developed for describing experiment and cavity volume/geometry by the use of standard geometric shapes (sphere, cylinder, and parallelepiped). Each experiment was represented by its total volume and the standard shape of its critical component. Each cavity was defined by its total volume and by its capacity to contain the standard shapes.
5. A methodology for describing experiment effectiveness as a function of the initial elements and/or mission parameters of the deployed orbit was developed, and parametric effectiveness analyses were performed on example experiments.
6. A computer program (SEPTER) was developed to evaluate and rate in-flight experimental payloads. The overall capabilities of this program are a result of the development of some unique and simplified methodologies which are reasonably

accurate for the solution of generally complex problems. These methodologies include the following:

- a. The simulation of experimental payload deployment modes and the calculation of the orbital elements and/or mission parameters for the deployed orbit.
  - b. The computation of experiment/mission effectiveness as a function of the initial orbital elements of the deployed orbit. A technique was developed in which three types of effectiveness factor relationships are utilized: (1) continuous function of two variables, (2) step function of two variables, and (3) continuous or step function of one variable. Two interpolation techniques are available.
  - c. The determination of the experimental payload-mission/vehicle compatibility with numerous physical and operational criteria. A reasonably simple technique was developed for the determination of geometric compatibility between arbitrarily shaped cavities and experimental payloads represented by standard shapes.
  - d. The determination of multiple experimental payload arrangements aboard a vehicle. A technique was developed which satisfies all constraints and directly searches for a non-unique "optimal" arrangement.
7. A computer program (DESIGN) for determining limited physical characteristics of arbitrary experiments was developed as a support program for Program SEPTER. DESIGN replaces the manual subsystem synthesis tasks of designing experimental payloads and provides "first-pass" estimates of mass and volume requirements.

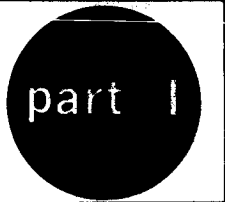

# **DESIGN OF SELECTED IN-FLIGHT EXPERIMENTS**



SECTION 2  
 APPROACH TO DESIGN OF  
 IN - FLIGHT EXPERIMENTS

It has been previously acknowledged that NASA has the prerogative and responsibility to define and approve in-flight experiments. It was necessary, however, in order to develop a workable computer methodology for the evaluation of such experiments, to define a number of experiments in order to establish typical requirements in terms of the physical characteristics of the packages and the experiment data-gathering objectives. The approach taken in defining these example experiments is outlined in Figure 2-1.

**GUIDELINE:** Experiments Are to be Defined Only to Establish Requirements of Representative Experiment Packages and Experiment/Mission Effectiveness

**APPROACH:**

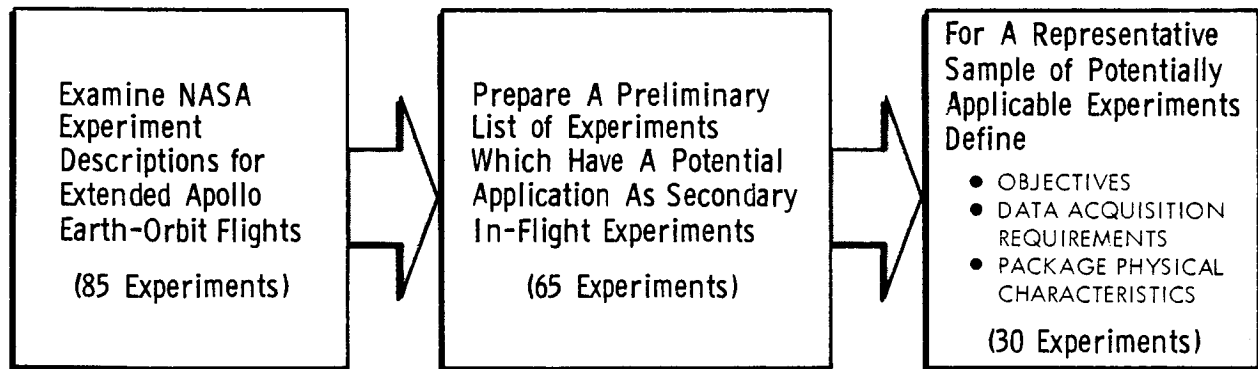

● **SCIENTIFIC AND TECHNOLOGICAL EXPERIMENT CATEGORIES**

- |  |  |
|--|--|
| 1. SYSTEMS DEVELOPMENT AND TEST                            | 4. SOLID/LIQUID/GAS BEHAVIOR   |
| 2. MATERIALS AND STRUCTURES                                | 5. MICROORGANISMS  |
| 3. MULTISPECTRAL IMAGERY OF THE EARTH AND ORBITING OBJECTS | 6. OBSERVATIONS OF THE EARTH'S ATMOSPHERE, SPACE ENVIRONMENT, ASTRONOMICAL PHENOMENA |

Figure 2-1 APPROACH TO DEFINITION OF EXPERIMENTS

The document NASA Experiment Descriptions for Extended Apollo Earth-Orbit Flights was reviewed, and the 85 experiments listed therein were examined to determine which of the experiments had a potential application as a secondary in-flight experiment. A number of the experiments were eliminated from consideration because of their incompatibility with the guidelines and ground rules established for the study. For example, in a number of the experiments, either a large payload capability or an excessive amount of astronaut

participation was required. It was found that approximately 65 of the 85 experiments contained in this document could be defined as secondary in-flight experiments.

Each of these 65 experiments was examined in terms of the physical characteristics of the experiment package (size, mass, etc.), the operational requirements for the sensor (deployment, viewing, etc.), and the data-gathering requirements related to elements of the orbit in which the sensor must be deployed. In this manner, 30 representative experiments were selected from the list of 65. This list of 30 was composed of 5 experiments in each of the six scientific and technological experiment categories indicated in Figure 2-1. The physical characteristics of the package, detailed objectives, and data acquisition requirements were determined for each of the 30 experiments.

Ancillary system characteristics were defined in the system detailed design on the basis of requirements related to the sensors, the experiment operations, and the environment. The physical characteristics of experiment sensors and ancillary systems were then used in achieving a configuration design for each experiment package. The results of the efforts on the individual in-flight experiment package designs have been expressed in terms of mass, volume/geometry (including critical dimensions), and other characteristics, and have been stored on library magnetic tapes for use in the SEPTER computer program.

A support program — DESIGN — has been developed for limited synthesis of arbitrary experiments. The approach used in developing the computer methodology is shown in Figure 2-2. To satisfy the given input requirements, the characteristics of ancillary systems have been defined by means of analytical representations in the form of curve fits or characteristics stipulated for required components.

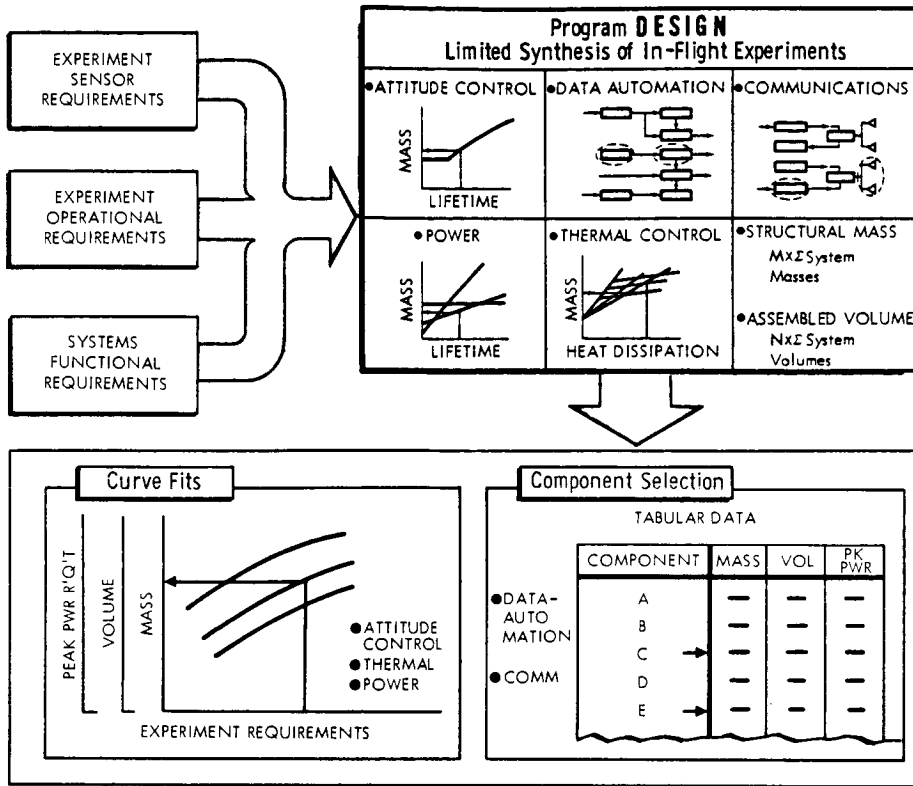

Figure 2-2 APPROACH TO LIMITED SYNTHESIS OF EXPERIMENTS

## S E C T I O N 3

### D E F I N I T I O N O F E X P E R I M E N T S

#### 3.1 SELECTION OF A REPRESENTATIVE SAMPLE OF POTENTIALLY APPLICABLE EXPERIMENTS

The experiments selected for inclusion in the experiment characteristics library of Program SEPTER are grouped under six scientific and technological experiment categories which were established by the Fort Worth Division to ensure broad coverage of the scientific and technical disciplines outlined in the document NASA Experiment Descriptions for Extended Apollo Earth-Orbit Flights. These six categories are (1) systems development and test; (2) materials and structures; (3) multispectral imagery of the Earth and orbiting objects; (4) solid/liquid/gas behavior; (5) microorganisms; (6) observations of the Earth's atmosphere, the space environment, and astronomical phenomena.

Presented in each of the following subsections (3.1.1 through 3.1.6) is a list of experiments that were selected from each category, together with a synopsis on each category.

##### 3.1.1 Systems Development and Test

The experiments relating to the first of the six categories are as follows:

- SDT-1. Radioisotope-Thermoelectric Power System Integration
- SDT-2. Performance Assessment of Thin-Film Solar Cell Arrays
- SDT-3. Performance Assessment of Spacecraft Navigation, Guidance and Control Hardware and Techniques
- SDT-4. Cryogenic Propellant Storage System Performance
- SDT-5. Launch of Unmanned Satellites and Probes

Developmental systems for space use can be tested and evaluated in an environment very nearly identical to the one that would be experienced beyond the vicinity of the Earth.

The opportunity to launch test articles as supplementary payloads into Earth orbit provides, at relatively low cost, the use of an environmental "laboratory" that cannot be duplicated on Earth. The unique environmental features that are available include weightlessness, high vacuum, and freedom from interference that is due to surrounding objects. Further, the effects of solar flares and a fluctuating thermal radiation environment can be studied.

Power supplies for space operations constitute an important class of systems that can be tested. New types of solar cells can be evaluated, and the operation of fuel cells in a space environment can be studied. Advanced power-supply concepts will also be developed, and an evaluation can be made of the ability of the power supply to operate in the space environment.

### 3.1.2 Materials and Structures

The experiments relating to the second of the six categories are as follows:

- MS-1. Degradation of Organic Materials in a Space Environment
- MS-2. Behavior of Liquid Films in a Space Environment
- MS-3. Vaporization Rate of Molten Metals
- MS-4. Cold-Welding of Metals in a Space Environment
- MS-5. Spray Coating and Surface Contamination in a Space Environment

There are many and varied environments encountered by engineering materials during prolonged periods in space. It is highly desirable to conduct investigations of the effect of these environments on applicable materials. Broadly speaking, there are two major categories of environments: those environments introduced by the spacecraft itself (e.g., temperatures from cryogenic to high temperatures, launch and acceleration loads, and vibration) and those environments normally associated with space (vacuum, micro-meteoroid concentration, Van Allen radiation belts, steady solar and flare emissions, and cosmic rays). The effect of the environments on the behavior of metals, plastics, and ceramics can be evaluated.

The presence of a vacuum condition can significantly affect the structure and properties of materials. The molecule loss of elements and the weight loss in organic compounds can be calculated and verified by laboratory experiments; however, there may be a risk involved in superimposing the damage caused by vacuum upon that caused by ions, electrons, and gas atoms.

### 3.1.3 Multispectral Imagery of the Earth and Orbiting Objects

The experiments relating to the third of the six categories are as follows:

- MI-1. Multispectral Surveillance of Earth
- MI-2. Infrared Line-Scan Surveillance of Earth

- MI-3. Radar Surveillance of Earth
- MI-4. Electronic Image Motion Stabilization
- MI-5. Synoptic Earth Cartography

The use of a satellite platform for observation of the Earth provides the opportunity for observing large areas of the Earth simultaneously.

Infrared imagery will permit observation of ocean currents and, possibly, of air masses; in addition, new techniques of weather observation could be developed and large-scale surveys of water resources and plant life can be made.

Studies of the ionosphere over long periods of time will extend the information acquired by sounding rockets. Correlation of ionospheric phenomena with atmospheric electrical effects may be possible.

The reflectivity and emissivity of other satellite bodies can be investigated without the interference of atmospheric attenuation, refraction, and scattering. These studies can be carried out at various radiation wave lengths.

#### 3.1.4 Solid/Liquid/Gas Behavior

The experiments relating to the fourth of the six categories are as follows:

- SLG-1. Boiling in Zero-Gravity Environment
- SLG-2. Nucleate Condensation in Zero-Gravity
- SLG-3. Formation of Single Crystals
- SLG-4. Segregation of Immiscible Liquids Under Zero-Gravity Conditions
- SLG-5. Zero-Gravity Combustion

More knowledge of the behavior of liquid/gas mixtures in free fall is required for the design of such items as fuel containers, transfer systems, and heat exchangers; these effects are particularly important for conditions at which boiling occurs.

Free nucleate boiling, boiling at heater surfaces (nucleate and film boiling), dynamics of isolated liquid drops suspended in gas, and boiling of certain liquids in the presence of electric fields are typical phenomena that should be studied. Some parameters to be investigated are bubble dynamics, heat transfer rates, temperature distributions, and pressures.

The difficulties experienced in free-fall boiling, pumping, etc. arise from the fact that there is no buoyance and no distinct interface. In boiling, for example, these difficulties are due to (1) the failure to maintain intimate contact between the liquid and the heater and (2) the condition of small heat flux.

Liquids having high dipole moments develop pressure gradients (and therefore buoyant forces) when they are subjected to electric fields. This effect should be studied to determine what application the effect has on improving heat transfer rates in devices during free fall.

### 3.1.5 Microorganisms

The experiments relating to the fifth of the six categories are as follows:

- M-1. Soft Capture, Enumeration, and Identification of Space-Borne Microorganisms
- M-2. Effects of Space Flight on Morphology, Growth, and Liquid/Gas Separation in Microorganisms
- M-3. Inherent Mutation Rates in Microorganisms and Effects of Extended Space Flight on the Expression of the Mutation
- M-4. Determination of the Migration of Microorganisms in a Spacecraft Environment
- M-5. Production of Nutrients by Certain Microorganisms While in Space Flight.

There are several microorganism-related experiments that can be included as secondary payloads. Experiments of this type will play an important role in determining the capability of man to survive in space.

One possible experiment would result in the determination of the effect of extended space flight on the production of nutrients (e.g., vitamins) by certain microorganisms. Certain microorganisms are used to produce added or supplemental nutrients for higher animals, including man. These nutrients are essential to maintain a good state of health, and, in many cases (e.g., yeasts), the whole organism is of vital importance. The environment of a space vehicle will create a need for an added supply of nutrients, especially on

extended missions. An efficient method of producing essential growth factors and basic nutrients employs the activities of microorganisms under continuous culture. The state of weightlessness may produce an undesirable effect on metabolic processes of these organisms and, as a consequence, may produce unsatisfactory or undesirable products in a fermentation process.

Another experimental program would be designed to collect information on the effect of radiation on microorganisms while they are exposed to the levels of cosmic radiation encountered during extended space flight. Selected microorganisms will be placed in an area of the space vehicle in which they would receive cosmic-radiation exposure.

### 3.1.6 Observations of the Earth's Atmosphere, the Space Environment, and Astronomical Phenomena

The experiments relating to the sixth and final category are as follows:

- OEA-1. Radiation Environment Monitoring
- OEA-2. Study of Magnetic Field Lines
- OEA-3. Test of Prototype Star Tracker
- OEA-4. Cosmic-Ray Emulsion Experiment
- OEA-5. Emission Line Radiometry

Use of an Earth-orbiting satellite as a base for astronomical and astrophysical observations has great advantages over Earth-based observations because the inherent effects of the Earth's atmosphere are removed. Although most of the astronomical observations utilize such instruments as large-size telescopes, coronagraphs and radio telescopes (which require nearly full capacity of a space vehicle), some simple, but still important, observations may be made within a limited space.

## 3.2 RELATIONSHIP TO NASA SCIENTIFIC/TECHNICAL AREAS

It should be noted that these six categories were selected primarily for convenience in defining typical experiments; consequently, they are only a general indication of the broad range of experiment categories that are actually covered by the selected 30 experiments. The relationship of the 30 selected experiments to NASA'S major scientific/technical areas of interest is indicated in Table 3-1. This table gives some idea of the scope of the experiments to be contained in the experiment characteristics library of Program SEPTER.



TABLE 3-1  
 RELATIONSHIP OF THE THIRTY EXPERIMENTS  
 SELECTED BY GENERAL DYNAMICS FOR THE STUDY TO THE NASA  
 MAJOR SCIENTIFIC/TECHNICAL AREAS OF INTEREST

NASA	General Dynamics
<b>Space Science</b> 1. PHYSICAL SCIENCES 2. BIOSCIENCE 3. ASTRONOMY/ASTROPHYSICS	OEA-1, OEA-2, OEA-4, SLG-1, SLG-2, SLG-3 M-1, M-2, M-3 OEA-5
<b>Support for Space Operations</b> 4. BIOMEDICINE/BEHAVIOR 5. ADVANCED TECHNOLOGY AND SUPPORTING RESEARCH 6. EXTRAVEHICULAR ENGINEERING ACTIVITIES 7. OPERATIONS TECHNIQUES AND ADVANCED MISSION SPACECRAFT SUBSYSTEMS	NONE  SDT-3, SDT-4 MS-1, MS-2, MS-3, MS-4, MS-5, SDT-2, SDT-5  SDT-1
<b>Earth Oriented Applications</b> 8. ATMOSPHERIC SCIENCE AND TECHNOLOGY ● EARTH SCIENCES AND RESOURCES 9. AGRICULTURE/FORESTRY 10. GEOLOGY/HYDROLOGY 11. OCEANOGRAPHY/MARINE TECHNOLOGY 12. GEOGRAPHY 13. COMMUNICATIONS AND NAVIGATION/ TRAFFIC CONTROL	OEA-3  } SUPPORTED BY MI-1, MI-2, MI-3, MI-4 AND MI-5  NONE

Only two of the 13 major scientific/technical areas are not covered by at least one of the 30 experiments. These areas are (1) Biomedicine/Behavior and (2) Communications and Navigation/Traffic Control. The Biomedicine/Behavior area is not covered because the experiments in this category are not compatible with minimum astronaut participation. A number of experiments in the area of Communications and Navigation/Traffic Control listed in NASA Experiment Descriptions for Extended Apollo Earth-Orbit Flights are suitable for consideration as potential secondary experiments (e.g., measurement of radio frequency radiation, wide-bandwidth transmission in space, and deployment of RF reflective structures) and were listed among the 65 applicable experiments. These particular experiments were not considered further because of the limited scope of the study.

### 3.3 SUMMARY OF SELECTED EXPERIMENTS AND THEIR REQUIREMENTS

A summary of sensor requirements for the 30 selected experiments is presented in Table 3-2. From an examination of the table it can be seen that a considerable variety in requirements has been encountered in choosing these representative experiments. For example, duty cycle requirements range from a few minutes per day to continuous operation. The in-flight duration required varies from 2 hours to 1 year. As might be expected, the requirements for accuracy, resolution, and data recovery also tend to be peculiar to each particular experiment.

**TABLE 3-2  
SUMMARY OF SENSOR REQUIREMENTS**

Sensors	Duty Cycle	In-Flight Duration	Accuracy	Data Recovery	
				Telemetry	Capsule

<b>1. Systems Development and Test</b>	SDT-1	CO <sub>2</sub> CONCENTRATOR, RTEG, H <sub>2</sub> O EVAPORATOR	CONTINUOUS	60 DAYS	—————	✓	
	SDT-2	SOLAR COLLECTORS STANDARD CELLS	10-30 MINUTES EACH WEEK	1 YEAR	+0.5 VOLT +2°F TEMP ±0.1 AMPERE	✓	
	SDT-3	IMU, TRACKERS, HORIZON SCANNER, COMPUTER	30 MINUTE PERIODS 10-30 HOURS OPERATION	14 DAYS	POSITION 0.01 N.MI. ACCEL 10 <sup>-6</sup> g VELOCITY 0.01 FPS ANGLE 1 SEC.	✓	
	SDT-4	SUN SENSOR INSTRUMENTATION: TEMP, PRESS, FLOW	CONTINUOUS	4 DAYS	POINTING ±3 DEGREES	✓	
	SDT-5	ENERGETIC PARTICLES EXPLORER	—————	—————	—————		

<b>2. Materials and Structures</b>	MS-1	SUN SENSOR THERMOCOUPLES	2 HOURS EVERY 10 HOURS	30 DAYS	TEMP ±3°R		✓
	MS-2	LIQUID FILM SENSOR	10 MINUTES EACH APOGEE	27 HOURS	—————	✓	
	MS-3	THERMOCOUPLES VAPORIZATION SENSOR	18 PERIODS 20 MIN. TO 4 HOURS	29 HOURS	TEMP ±10°F	✓	
	MS-4	COLD WELD SENSOR	10 PERIODS 4 HOURS	15 HOURS	—————	✓	
	MS-5	SPRAY COATING SENSORS	3 PERIODS 2 HOURS & 10 MIN	2.5 HOURS	—————	✓	

<b>3. Multispectral Imagery of the Earth and Orbiting Objects</b>	MI-1	PHOTOGRAPHIC CAMERAS, SPECTRORADIOMETERS, V/h SENSOR	40 DATA RUNS 1 MINUTE EACH	2 WEEKS	POINTING ± 1.5 DEG	✓	✓
	MI-2	IR LINE SCANNER	15-20 DATA RUNS 3-4 MINUTES EACH	2 WEEKS	POINTING ± 2 DEG VERT, ± 3 DEG AZIM	✓	
	MI-3	SIDE LOOKING RADAR	1 HOUR PER DAY	2 WEEKS	30 METERS GROUND RESOLUTION (185 Km ORBIT)	✓	
	MI-4	CAMERA, TELESCOPE FINDER/TRACKER	50 PER DAY 20 SECONDS EACH	1 WEEK	12.2 METERS GROUND RESOLUTION (185 Km ORBIT)	✓	
	MI-5	CAMERA V/h SENSOR	5 RUNS PER DAY 11 MINUTES EACH	20 DAYS	15 m. HORIZ GRND RESOLUTION 25 m. VERT GRND RESOLUTION TIME 0.01 SEC		✓

<b>4. Solid/Liquid/Gas Behavior</b>	SLG-1	HI-SPEED CAMERA	1 OPERATIONAL CYCLE	2 HOURS	TEMPERATURE ± 1°K PRESSURE ± 2%	✓	✓
	SLG-2	PHOTOMETER	1 OPERATIONAL CYCLE	24 HOURS	TEMP 0.2°C TIME 0.1 SEC PRESS 0.1 psi	✓	
	SLG-3	SOLAR COLLECTOR PHOTOCELL PYROMETER	EACH ORBIT	15 HOURS	TEMP ± 20°C TIME 1 SEC PRESS 1 x 10 <sup>-1</sup> torr		✓
	SLG-4	CAMERAS	8 TEST CELLS 6-10 MINUTES EACH	2 HOURS	0.1 mm DROPLET DIAMETER		✓
	SLG-5	PRESSURE TRANSDUCERS, THERMOCOUPLES, GAS CHROMATOGRAPH	1 OPERATIONAL CYCLE	35 HOURS	1 mg DROPLET MASS, TIME 0.1 SEC TEMP 1°C PRESS 0.1 psi	✓	

<b>5. Microorganisms</b>	M-1	MICROSCOPE TV CAMERA	—————	14 DAYS	MICRON RESOLUTION	✓	
	M-2	SPECTROPHOTOMETER MICROSCOPE, GAS CHROMATOGRAPH	OBSERVATIONS EVERY 4-6 HOURS	3.5 DAYS	MICRON RESOLUTION	✓	
	M-3	MICROSCOPE TV CAMERA	1 HOUR EVERY 2 DAYS	10 DAYS	100 MICRONS RESOLUTION	✓	
	M-4	MICROSCOPE TV CAMERA	EVERY 2 DAYS	30 DAYS	10X MAGNIFICATION	✓	
	M-5	PHOTOMETER	EVERY HOUR FOR 5 DAYS THEN ONCE EVERY 2 DAYS	15 DAYS	TYPICAL PHOTOMETRIC RESOLUTION	✓	

<b>6. Observations of the Earth's Atmosphere, the Space Environment, and Astronomical Phenomena</b>	OE-1	SPECTROMETERS DETECTORS	CONTINUOUS	3.5 DAYS	57 DEG RESOLUTION	✓	
	OE-2	ELECTRON GUN MAGNETOMETER	CONTINUOUS	3.1 DAYS (50 ORBITS)	POINTING ± 5 DEG	✓	
	OE-3	2 STAR TRACKERS INERTIAL PLATFORM	6 - 1 MIN. READINGS EACH 4 ORBITS	5 DAYS	ANGLE RESOLUTION 1 SEC POINTING 0.5 DEG EA. AXIS	✓	
	OE-4	NUCLEAR EMULSION PACKAGE	1 OPERATIONAL CYCLE	5 DAYS	HALF CONE ANGLE 40 DEG POINTING ± 1 DEG		✓
	OE-5	INTERFEROMETER TELESCOPE	20 MINUTES EVERY 2 DAYS	14 DAYS	5%	✓	

SECTION 4  
DEFINITION OF ANCILLARY  
SYSTEMS

4.1 GENERAL

The definitions of experiment sensor requirements were used to determine the functional requirements to be specified for ancillary systems such as attitude control, data automation, communications, power, and thermal control. In the case of each experiment, an effort was made to employ the most promising system concepts possible with state-of-the-art components. Experiment-package configuration efforts were undertaken to ensure design feasibility, to obtain the required physical characteristics, and to allow interpretation of the experiment package/launch vehicle interface.

Power requirements, sensor pointing requirements, and the necessity, in some cases, of physically recovering a portion of the experiment package influenced the definition of the overall experiment-package physical characteristics. Other analyses have been made, and other requirements have been delineated for each experiment package to produce the total required outputs to be stored on the experiment-characteristics library tape. The required outputs consist of such characteristics as mass, volume/geometry, environmental data, reliability, deployment requirements, development time, and cost.

The following sections contain definitions of the ancillary systems to be used in each experiment for (1) attitude control, (2) data automation, (3) communications, (4) electric power, and (5) thermal control.

4.2 ATTITUDE CONTROL

The use of an attitude determination and control system enables the orientation of satellite body axes to be known in relation to some primary coordinate frame of reference and to be aligned precisely for sensor pointing. Normally, the design of attitude control, torque-producing mechanisms is based on a thorough knowledge of satellite size and configuration, mission duration, sensors, disturbance torques, and other factors. Candidate concepts for stabilization include the use of gas jets, spinning, gravity gradient, and (possibly) reaction wheels.

To simplify the task of determining the physical characteristics of an attitude control system for each experiment in which stabilization is required, parametric design data were generated by the use of experiment MI-1 (Multispectral Surveillance of Earth) as a reference example. This reference experiment required attitude stabilization for a lifetime of 2 weeks with a pointing accuracy of  $\pm 1.5$  degrees. Satisfaction of these requirements resulted in the choice of a 500-pounds-second impulse system having a mass of 58 pounds, a volume of 1565 cubic inches, and a power requirement of approximately 50 watts. As shown in Figure 4-1, the mass of the system is a function of the required total system impulse which in turn depends on lifetime and pointing accuracy requirements.

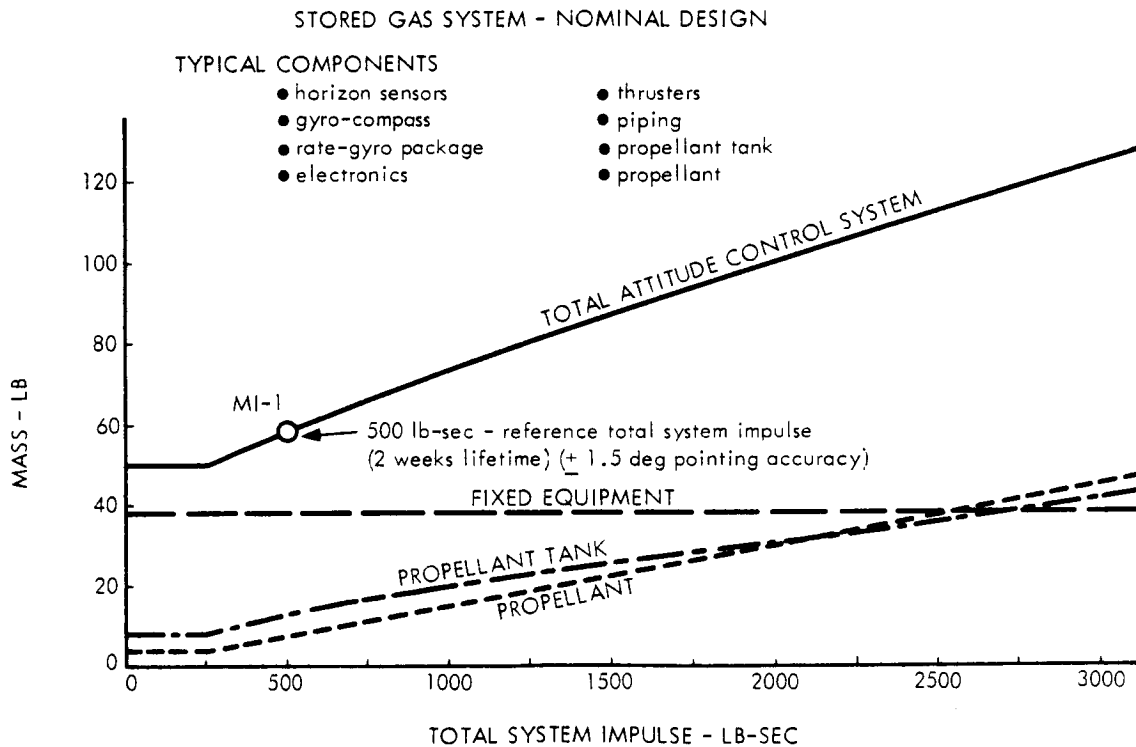

● SYNTHESIS APPROACH - CURVE FITS

Figure 4-1 ATTITUDE CONTROL

A stored-gas system was chosen on the basis of simplicity and reliability. It is assumed that the function of the attitude control system is to maintain the vehicle in one of two desired attitude throughout its specified lifetime (i.e., Earth or solar orientation). The vehicle is assumed to be ejected from its booster in this attitude. Initially, the attitude control system must remove ejection disturbances by driving the rates about all three body axes to zero. The body-mounted rate gyros furnish signals for this purpose and also provide damping in the control loop. Soon after ejection, the horizon sensors, in the case of earth-pointing situations, are activated to provide attitude error signals in the pitch and roll.

portions of the system. Yaw attitude-error signals are provided by an inertial gyro-compassing device. This system provides control for all orbit inclinations from equatorial to polar. For orbits in the equatorial plane, the gyro-compass could be replaced by a Polaris star sensor in order to reduce system mass. For orientation with respect to the sun, the horizon sensors could be replaced by sun sensors.

The mass of propellant and the propellant tank mass vary as a function of total-system impulse. The mass of remaining items is constant because these items are essentially fixed equipment.

### 4.3 DATA AUTOMATION

The data automation system is used to provide the optimum interface between the sensors and the communications system for the experiment. To assist in determining the applicable data automation equipment required for each experiment, a generalized flow diagram, shown in Figure 4-2, was produced to illustrate the processing of the following four specified types of data: scientific and engineering, television, infrared, and photographic. These data are routed and the duty cycles controlled by a central programmer in the manner described below.

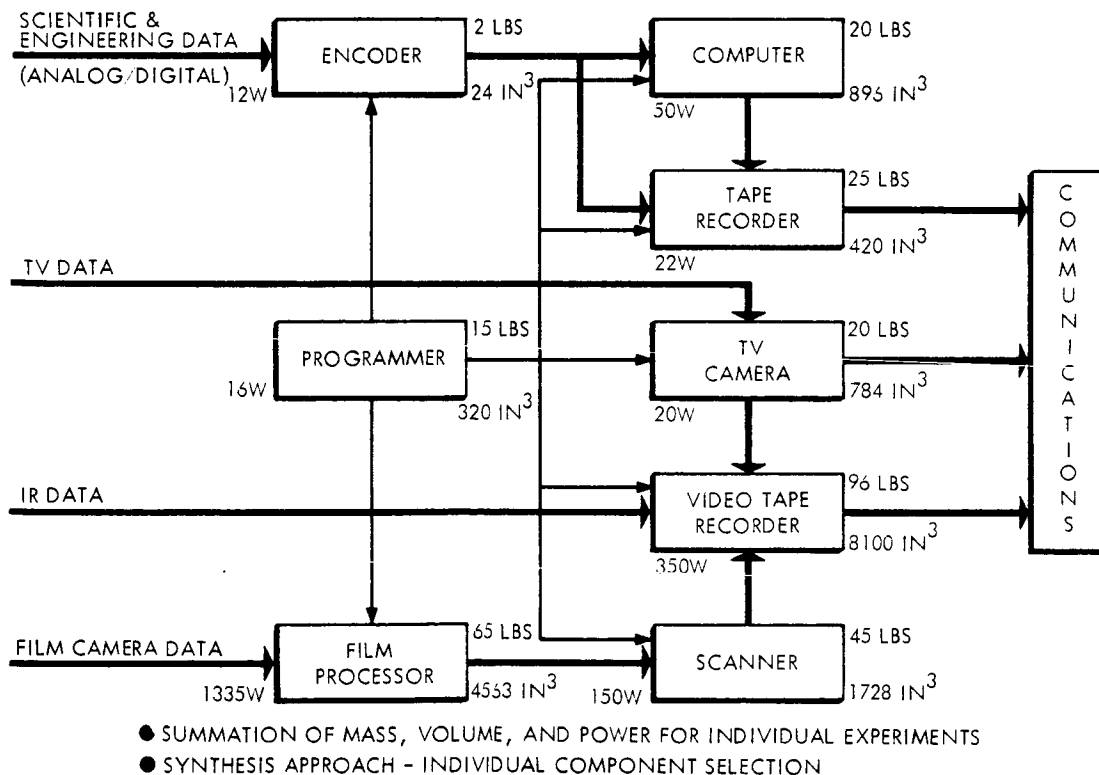

Figure 4-2 DATA AUTOMATION

1. Scientific and engineering information is routed through an encoder which multiplexes, conditions, digitizes (if necessary), and formats both analog and digital data. The data output of the encoder is either placed on a magnetic tape recorder or processed and compressed by a digital computer before being recorded. The data is then available for transfer to the communications system for transmission.
2. Television coverage is to be provided by one or more TV cameras whose output is either read out directly through the communications system or recorded by a video tape recorder for delayed playback.
3. Infrared data from the IR scanners are routed to a video tape recorder for delayed playback.
4. Exposed photographic film from the cameras is received by the automatic film processors. After being processed, selected frames are scanned by a flying-spot scanner whose output signals are placed on a video tape recorder. This information, like the television and infrared data, is then available for transmission whenever readout is desired. In some cases, it may be desired to recover film camera data physically by means of a re-entry capsule and to require no on-board film processing.

As detailed write-ups defining data automation requirements on each experiment were received, a comparison was made with the previously prepared generalized data automation flow diagram. This comparison resulted in an experiment-specific flow diagram which illustrated the required data processing between the sensor outputs and the communications system inputs.

A chart (see Appendix C) was compiled for each experiment which defined the individual and total size, mass, power, and environmental characteristics of the data automation system elements contained in the experiment-specific flow diagram. The physical characteristics of the experiment equipment were assigned by the experiment designer for each experiment. The characteristics of the data automation equipment were obtained from information acquired through a thorough search of various publications and vendor brochures.

To facilitate future automatic system definition, data-automation equipment size, weight, and power requirements were specified in a format compatible for input into a digital-computer storage and

retrieval program. Whenever the equipment had more than one distinct level of capability, a set of parameters was assigned to each level.

#### 4.4 COMMUNICATIONS

The communications system used in conjunction with each experiment is design limited to meet only those requirements peculiar to that experiment. The UHF equipment includes a command receiver and a digital or an analog transmitter. The S-band equipment includes a transmitter and a transponder. These units are considered to be standard equipment and within the present-day state of the art.

The communication capability has been divided in accordance with the functions to be performed. The information received from Earth will consist of commands to be used by the satellite programmer for starting and stopping the experiment and turning ancillary equipment on and off. Information to be relayed to Earth will consist of video, analog, and digital data obtained from the on-board sensors. The type of data will determine the number and type of output transmitters required and will vary with each experiment. The satellite construction and stability requirements affect the number of antennas needed on a specific experimental satellite. A line-of-sight capability is to be maintained at all times with the Earth station. Flush-mounted antennas are to be considered whenever mission requirements will permit; however, turnstile-type antennas appear to offer a better omnidirectional type of coverage so that fewer antennas are required.

The mass in pounds, volume in cubic inches, and input power in watts are shown in Figure 4-3 for each unit of the communications system. The final antenna design is considered to be a function of satisfying satellite physical and attitude-control requirements; therefore, antenna size and type are selected only after mission requirements are completed.

The peak power values shown are typical of present-day state-of-the-art components. It is anticipated that by 1970 power requirements for an S-band transponder and an S-band TV transmitter will be 10 and 15 watts respectively.



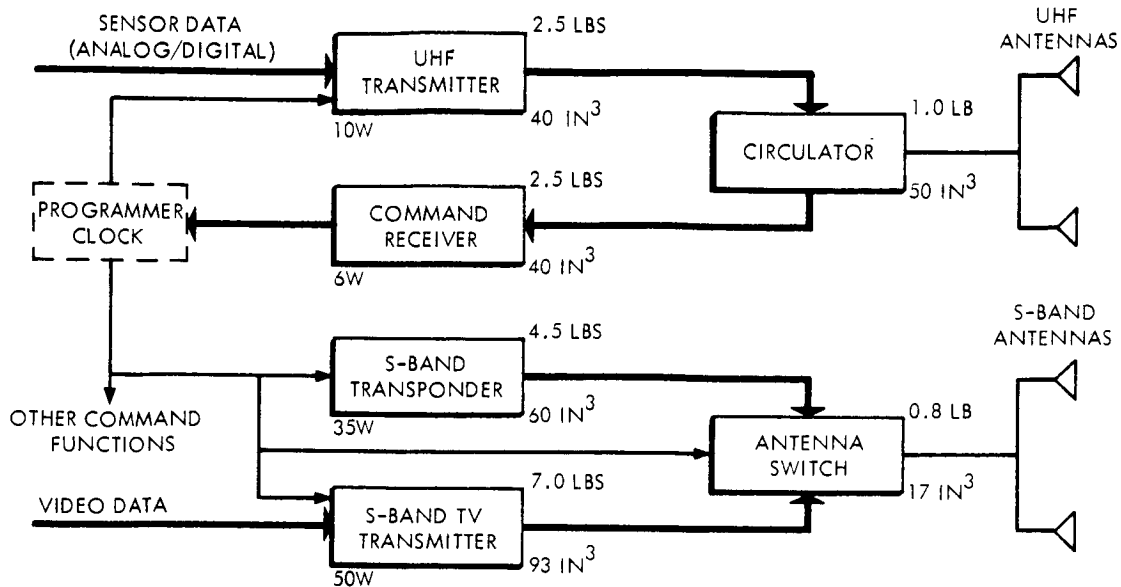

- SUMMATION OF MASS, VOLUME, AND POWER FOR INDIVIDUAL EXPERIMENTS
- SYNTHESIS APPROACH - INDIVIDUAL COMPONENT SELECTION

Figure 4-3 COMMUNICATIONS

#### 4.5 ELECTRIC POWER

Candidate power systems suitable for orbiting experiments include batteries, fuel cells, solar cells, and RTG's (Radioisotope-Thermoelectric-Generator). Each application must be analyzed to determine which system best serves a particular situation. Optimization may be performed in terms of mass, volume, reliability, dollar cost, or some combination thereof. The theoretical possibility exists of expressing all but one of the variables in terms of the other. Such a process is difficult to achieve practically, since sufficient data and value assessments do not exist to establish meaningful relative weighting. The high cost of launching a system into orbit and the extreme penalty involved with even minor performance malfunctions have resulted in an emphasis on mass optimization within acceptable reliability constraints.

1. BATTERY SYSTEM

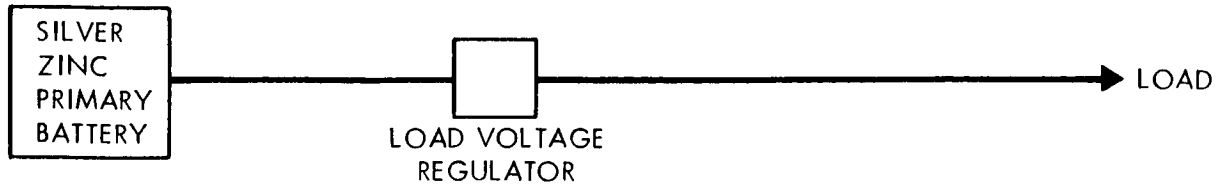

2. SOLAR PHOTOVOLTAIC & BATTERY

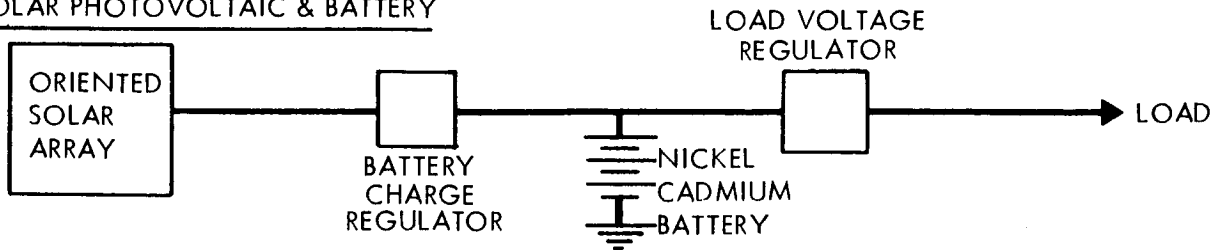

3. RADIOISOTOPE - THERMOELECTRIC - GENERATOR DIRECT

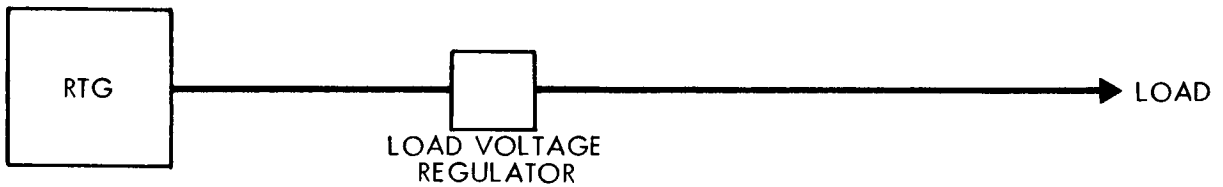

4. RADIOISOTOPE - THERMOELECTRIC - GENERATOR WITH BATTERY

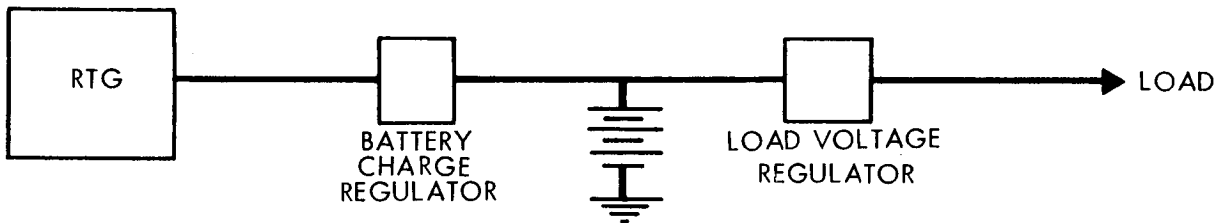

5. FUEL CELL DIRECT:

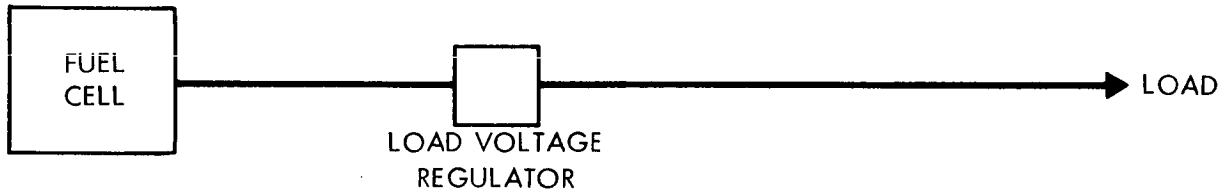

6. FUEL CELL WITH BATTERY:



Figure 4-5 POWER SYSTEM CONFIGURATIONS

Presented in Figure 4-4 is the well-known plot that illustrates the optimum power system in terms of mass as a function of power output versus duration time. The major portion of the secondary experiments analyzed in this study involve power and time requirements that either fall within or near the boundary of the battery area. Mass is less critical in these situations because of the nature of the secondary-experiment objectives.

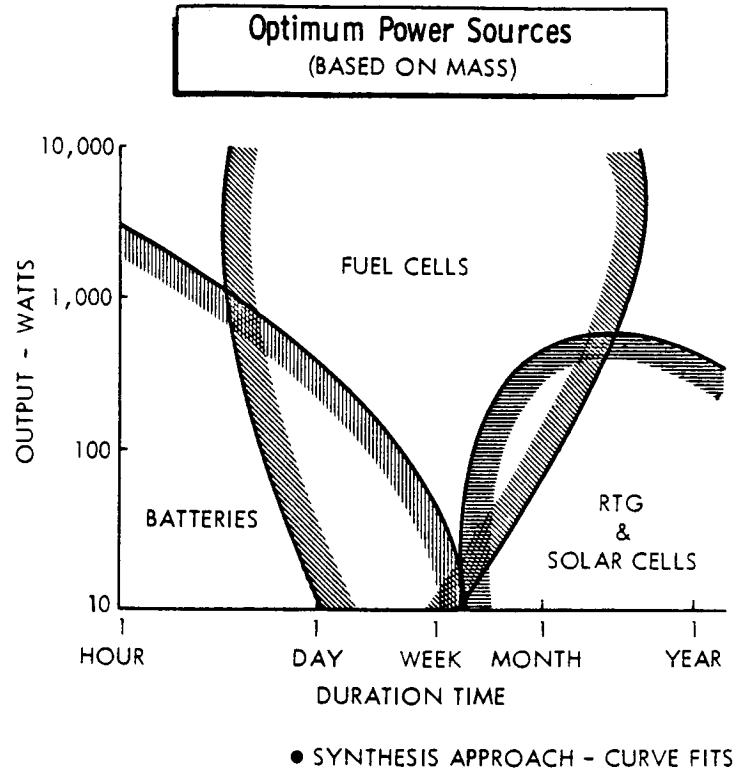

Figure 4-4 OPTIMUM POWER SOURCES

Several of the experiments involve requirements that fall well outside of the battery area and therefore require detailed analysis. Illustrated in Figure 4-5 are the six power-system configurations that were analyzed. A notable example of this analysis is the MI-3 experiment, Radar Surveillance of Earth. As shown in Table 4-1, a relative high-power requirement exists for one hour with a low demand at other times. Hence, consideration is given to the application of secondary batteries with each of the energy converters to enable continuous operation.

The results of the analysis are presented graphically in Figure 4-6. For periods of up to 5 days, the battery-system configuration is lighter. For the interval of from 5 to 25 days, the direct-fuel cell configuration is more advantageous. Beyond 25 days, the solar-photovoltaic and battery configuration is lightest. The remaining configurations were found to be overweight at all time periods.

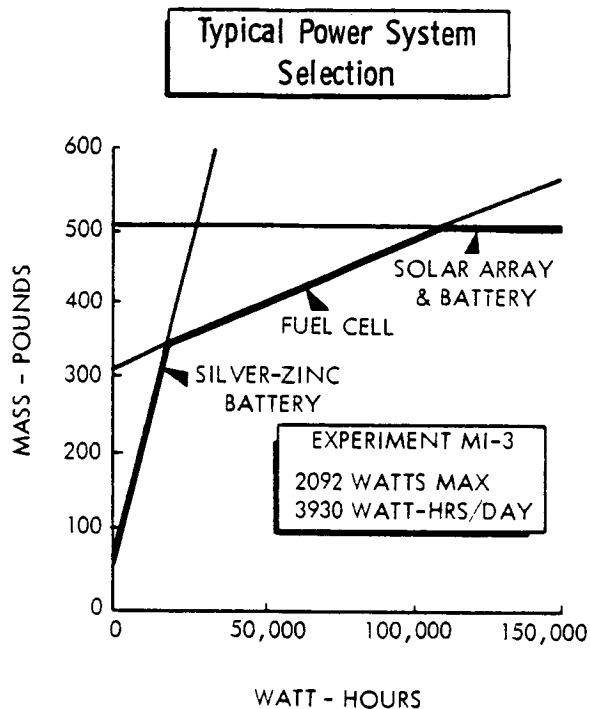

Figure 4-6 TYPICAL POWER SYSTEM SELECTION

General expressions which approximate the mass, volume, and area for five configurations have been developed. Each dimension was developed in terms of peak power (X), watt-hours/day (y), and days (D). The results are given in Figure 8-8 in Section 8 of this document.

#### 4.6 THERMAL CONTROL

Proper operation of the individual experiments will be dependent upon the inclusion of an adequate thermal control system within the experiment package design. A thermal analysis of each experiment was performed to size the system in terms of the mass, the volume, and the power requirements. The basic guidelines used to define the thermal control system were the following: (1) the system must

The numerical analyses are based on the following:

Primary Batteries

Type: zinc-silver oxide  
 Energy Density: 75 watt-hr/lb  
 Density: 100 lb/ft<sup>3</sup>

Secondary Batteries

Type: nickel cadmium  
 Energy Density: 12 watt-hr/lb  
 Density: 144 lb/ft<sup>3</sup>  
 Discharge-charge Efficiency: 75%

Solar-Photovoltaic Array

Type: single crystal silicon,  
 non P  
 Watts/ft<sup>2</sup> Oriented: 10  
 Watts/lb Active: 10

Fuel Cells

Converter Mass = 150 lb/kw  
 Reactant Mass = 1 lb/kw-hr  
 Tankage Mass = Reactant Mass

Power Conditioning & Battery  
 Charge Regulator

Mass = 5 + watts x 0.01 lb  
 Volume = 20 in<sup>3</sup>/lb

Distribution Mass

Taken to be equal to power  
 conditioning

Power conditioning and distribution combined efficiency: 80%

Table 4-1 EXPERIMENT MI-3 LOAD DATA

Item	Watts	Time*
Sensor	1700	1
Programmer	16	2
Data Automation	300	2
Data Transmission	15	1
Beacon & Command Receiver	16	24
Attitude Control	50	24

\* On time in hours/day

environment over the mission phases (prelaunch, launch, and orbit) were taken into account to ensure adequate performance throughout the mission.

#### 4.7 ANCILLARY SYSTEMS MASS SUMMARY

A summary of ancillary systems masses for the 30 sample experiments considered in the study is presented in Table 4-2. Values are shown for attitude control, data automation, communications, electric power, and thermal control systems.

TABLE 4-2  
ANCILLARY SYSTEMS MASS SUMMARY

SDT-1	SDT-2	SDT-3	SDT-4	SDT-5	MS-1	MS-2	MS-3	MS-4	MS-5	MI-1	MI-2	MI-3	MI-4	MI-5	SLG-1	SLG-2	SLG-3	SLG-4	SLG-5	M-1	M-2	M-3	M-4	M-5	OEA-1	OEA-2	OEA-3	OEA-4	OEA-5		
<b>Attitude Control</b>																															
118	⊗	52	50	⊗	95	*	*	*	*	58	58	124	96	124	*	*	42	*	*	⊗	*	⊗	⊗	⊗	⊗	*	50	43	50	58	
<b>Data Automation</b>																															
29	2	18	24	⊗	323	23	28	28	28	236	120	271	121	1023	110	29	329	100	19	10	12	20	10	29	36	13	19	101	29		
<b>Communications</b>																															
12	7	12	12	⊗	10	12	12	11	11	12	17	17	16	9	4	12	9	⊗	12	17	17	17	17	12	4	7	7	9	12		
<b>Electric Power</b>																															
336	⊗	222	211	⊗	179	41	82	60	50	405	378	445	234	321	27	97	74	34	72	94	38	100	57	124	183	64	130	137	314		
<b>Thermal Control</b>																															
24	3	5	10	2	2	1	1	3	2	8	36	36	19	20	5	3	16	9	3	18	1	6	7	4	1	5	4	4	28		

\* REMAINS ON-BOARD VEHICLE      ⊗ NO REQUIREMENT

not interfere with the primary payload, (2) the experiment must be self-contained, and (3) passive thermal control should be used if possible.

Selection of a thermal control concept for a particular experiment was based on consideration of the thermal requirements for the experiment (allowable temperature range and heat dissipation), the physical characteristics of the experiment, the probable thermal environment, and the relationship between the stored and operating periods and the mission phases (prelaunch, launch, and orbit). Generally speaking, thermal-control concepts may be categorized as passive, semi-active, or active, the latter of which allows a greater degree of thermal control at the expense of reliability. Examples of specific concepts within each category are included in Figure 4-7. In certain situations, combinations of concepts, e.g., insulation used in conjunction with a heater and thermostat may be used to advantage.

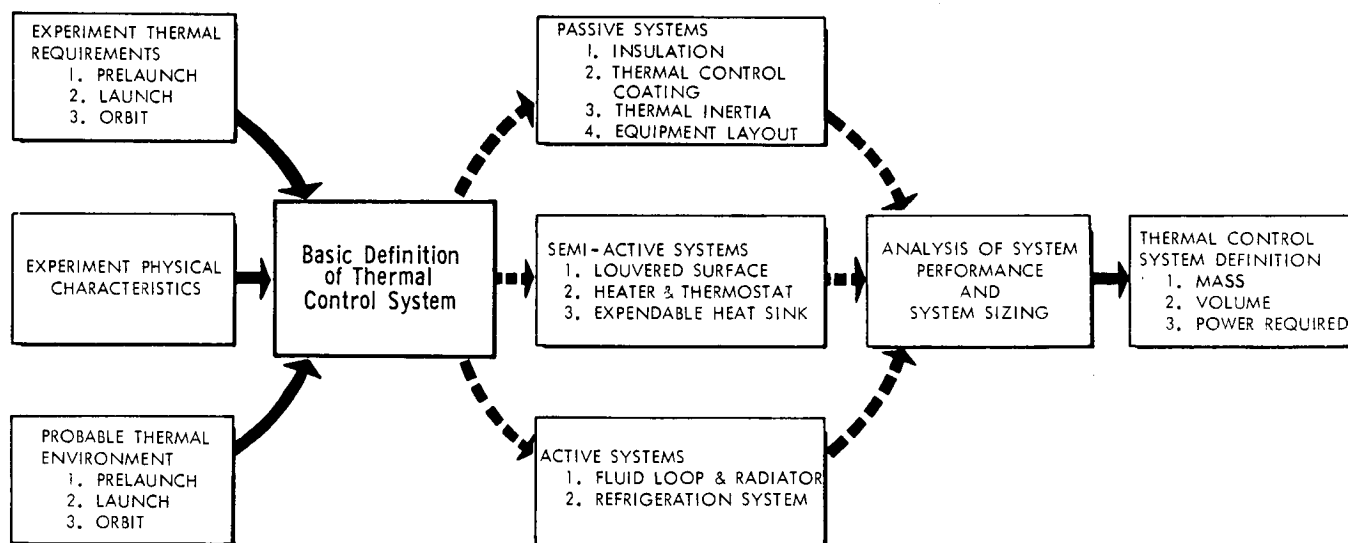

● Synthesis Approach - Curve Fit

Figure 4-7 APPROACH TO THERMAL CONTROL SYSTEM DESIGN

With the thermal control concept selected, analysis of thermal control system performance was undertaken with respect to the experiment thermal requirements and the probable thermal environment. Variations in the experiment thermal requirements and the thermal

SECTION 5  
EXPERIMENT ENVIRONMENTAL  
REQUIREMENTS

5.1 GENERAL

It was necessary to determine the environmental requirements of each experiment in order to:

1. Provide an environmental compatibility check between experiments and vehicle locations
2. Define environmental control system mass penalties.

The following environments were investigated for applicability and significance to this program: thermal, acoustic, vibration, shock, acceleration, humidity, pressure/vacuum, electromagnetic, radiation, and contamination (dust, fungus, salt spray, etc.). Since the primary objective of this study was the development of a computer methodology, the environments that would not significantly contribute to this methodology development were eliminated from further consideration. In general, those environments that were eliminated from consideration are those that are not peculiar to a specific launch vehicle or a specific location on the vehicle, thereby limiting the number of required compatibility checks to one. This check can best be accomplished externally of the program by the assignment to the experiments of qualification specifications that are compatible with the launch vehicle. The following environments were found to be applicable and significant to the development of the program: thermal, vibration, acoustic, and electromagnetic. The definition of requirements for each of these environments is shown in Figure 5-1.



**THERMAL**

- Maximum and Minimum Temperature
- Heat Dissipation Rate
- Total Heat Dissipation

**VIBRATION**

- Assume Qualified Per Spec MIL-E-5272C Procedure XII

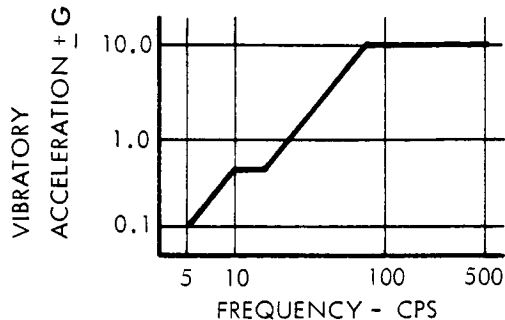

**ACOUSTICS**

- Noise Tolerance of 150 db Overall Per MIL Standard 810 Acoustical Test Method Grade B

**ELECTROMAGNETIC**

- Transmitter Signal Receiver Sensitivity

Figure 5-1 EXPERIMENT ENVIRONMENTAL REQUIREMENTS

## 5.2 THERMAL

In order to predict accurately the thermal environment of an equipment, the environment in which the experiment operates must be known. An actual experiment would be designed for a single mission and for a known thermal environment. For this study it was necessary to define a set of vehicle thermal environments to be used in predicting the experiment thermal environments. These vehicle environments, which are shown in Table 5-1, are based on a preliminary thermal analysis of the launch vehicle.

The thermal environment for each of the experiments was defined by three parameters:

1. Maximum and minimum allowable time-space averaged temperature
2. Heat dissipation rate
3. Total short-period heat dissipation.

Table 5-1

## LAUNCH VEHICLE THERMAL ENVIRONMENT

Mission Phase	Time-Space Averaged Environment Temperature °F	Maximum Rate of Heat Dissipation Btu/hr	Maximum Total Short Period Heat Dissipation Btu
Prelaunch	35 to 75	200	17
Launch	15 to 240	100	17
Orbit	-105 to 140	300	17

These parameters (refer to Table 5-2) were determined for each of three mission phases: launch, prelaunch, and orbit. Since those experiments that are ejected from the spacecraft must be compatible with an orbital operational environment not associated with the spacecraft, no thermal compatibility checks will be made in the orbit mission phase for ejected experiments. The time-space averaged temperatures are the maximum and minimum temperatures to which the experiment components can be subjected without causing malfunctions. These temperatures were obtained from an analysis of the temperature-sensitive components in each experiment. The heat dissipation rate and total short-period heat dissipation were obtained from an analysis of the power output of the experiment and the amount of heat absorbed within the experiment (i.e., by a water boiler). The data shown in Table 5-2 were based on preliminary analyses of experiment components and are to be considered only as reasonable estimates made for the purpose of the computer program.

## 5.3 VIBRATION

Because the experiment vibration tolerance is very difficult to determine by analysis, the only meaningful vibration tolerance levels are those levels to which the experiment components have been qualified by testing. Two types of specification can be used in describing the vibration tolerance: random and sinusoidal. Because many off-the-shelf components have not been qualified to the random vibration specification, only sinusoidal vibration levels were considered in the compatibility checks. For the purposes of the

TABLE 5-2  
EXPERIMENT THERMAL ENVIRONMENT

Self-Constrained Experiments

EXPERIMENT	Prelaunch				Launch				Orbit			
	T <sub>EMAX</sub> (°F)	T <sub>EMIN</sub> (°F)	Q̇ <sub>E</sub> (BTU/HR)	Q <sub>E</sub> (BTU)	T <sub>EMAX</sub> (°F)	T <sub>EMIN</sub> (°F)	Q̇ <sub>E</sub> (BTU/HR)	Q <sub>E</sub> (BTU)	T <sub>EMAX</sub> (°F)	T <sub>EMIN</sub> (°F)	Q̇ <sub>E</sub> (BTU/HR)	Q <sub>E</sub> (BTU)
SDT-1	100	0	0	0	250	0	0	0		EJECTED		
SDT-2	100	0	0	0	250	0	0	0		EJECTED		
SDT-3	80	35	0	0	250	35	0	0		EJECTED		
SDT-4	80	0	0	0	250	0	0	0		EJECTED		
SDT-5	100	0	0	0	250	0	0	0		EJECTED		
MS-1	75	35	0	0	240	35	0	0		EJECTED		
MS-2	75	14	27.3	N/A	260	0	27.3	N/A	65	-50	225	N/A
MS-3	75	14	27.3	N/A	240	0	27.3	N/A	65	-50	232	N/A
MS-4	75	14	27.3	N/A	250	0	27.3	N/A	65	-50	191	N/A
MS-5	75	14	27.3	N/A	250	0	27.3	N/A	65	-50	198	N/A
MI-1	80	30	0	0	300	30	0	0		EJECTED		
MI-2	100	20	0	0	400	20	0	0		EJECTED		
MI-3	100	0	0	0	400	0	0	0		EJECTED		
MI-4	100	0	0	0	400	0	0	0		EJECTED		
MI-5	90	10	0	0	400	10	0	0		EJECTED		
SLG-1	90	20	0	0	250	20	0	0	0	-50	1970	N/A
SLG-2	212	32	0	0	350	32	0	0	75	0	150	N/A
SLG-3	75	14	0	0	300	0	0	0		EJECTED		
SLG-4	75	35	0	0	250	35	0	0	65	20	392	N/A
SLG-5	75	14	0	0	250	0	0	0	75	-50	239	N/A
M-1	100	25	0	0	250	25	0	0		EJECTED		
M-2	80	0	17.1	N/A	250	0	17.1	N/A	80	0	17.1	N/A
M-3	80	0	20	N/A	250	0	20	N/A		EJECTED		
M-4	85	0	3.5	N/A	200	0	3.5	N/A		EJECTED		
M-5	90	0	3.5	N/A	250	0	3.5	N/A		EJECTED		
OEA-1	75	25	0	0	250	25	0	0	60	-50	394	N/A
OEA-2	100	0	0	0	200	0	0	0		EJECTED		
OEA-3	80	35	0	0	250	35	0	0		EJECTED		
OEA-4	75	35	0	0	250	35	0	0		EJECTED		
OEA-5	100	0	0	0	250	0	0	0		EJECTED		
Vehicle-Dependent Experiments												
MS-2A	75	14	27.3	N/A	260	0	27.3	N/A	65	-50	202	N/A
MS-3A	75	14	27.3	N/A	240	0	27.3	N/A	65	-50	196	N/A
MS-4A	75	14	27.3	N/A	250	0	27.3	N/A	65	-50	181	N/A
MS-5A	75	14	27.3	N/A	250	0	27.3	N/A	65	-50	132	N/A
SLG-1A	90	20	0	0	250	20	0	0	0	-50	1960	N/A
SLG-2A	212	32	0	0	350	32	0	0	75	0	112	N/A
SLG-4A	75	35	0	0	250	35	0	0	65	20	392	N/A
SLG-5A	75	14	0	0	250	0	0	0	75	-50	172	N/A
M-2A	80	0	17.1	N/A	250	0	17.1	N/A	80	0	14	N/A
OEA-1A	75	25	0	0	250	25	0	0	60	-50	362	N/A

T<sub>E</sub> - TIME-SPACE AVERAGED SINK TEMPERATURE  
Q̇<sub>E</sub> - HEAT DISSIPATION RATE  
Q<sub>E</sub> - TOTAL SHORT-PERIOD HEAT DISSIPATION

computer program, a vibration tolerance level which would apply to the majority of off-the-shelf components was assigned to all experiments. This maximum sinusoidal vibration level, shown in Figure 5-2, is per MIL-E-5272C, Procedure XII. In an actual case, the vibration level would be based on the vibration specification to which the experiment or its components had been qualified.

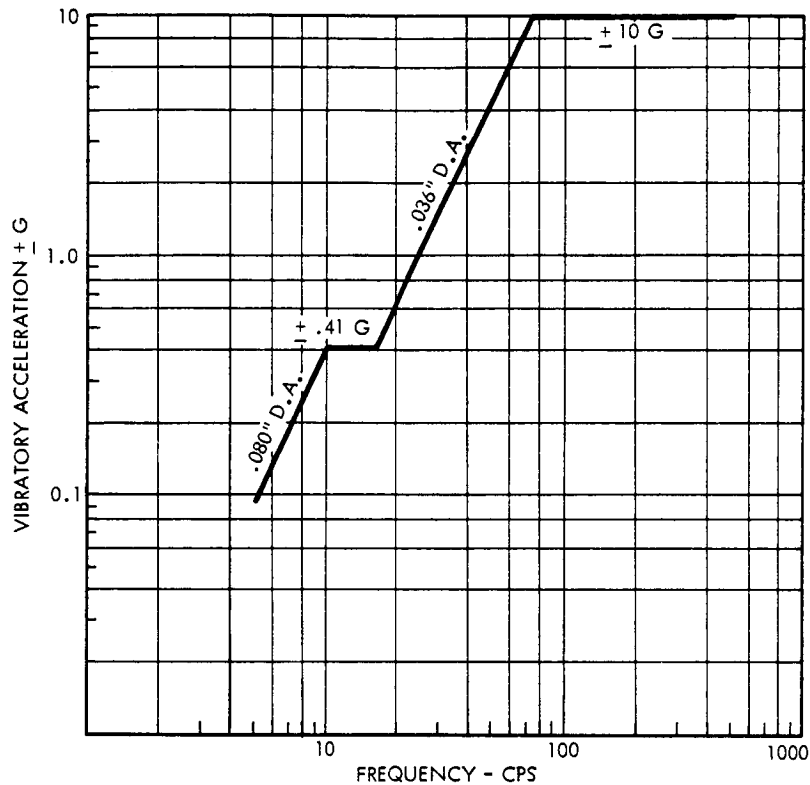

Figure 5-2 EXPERIMENT VIBRATION ENVIRONMENT

#### 5.4 ACOUSTICS

The same difficulty is encountered in defining the acoustical noise tolerance of the experiments as was encountered in defining the vibration tolerance. The tolerance levels assigned to the experiments can only be as high as the levels to which the experiment components have been qualified by testing. Because off-the-shelf components were used, whenever possible, in the experiment definitions, a maximum noise tolerance of 150 db overall was assigned to all experiments. This value is per MIL Standard 810, "Acoustical Test Method, Grade B." For an actual experiment, the noise tolerance would be determined by the acoustics specification to which the experiment or its components had been qualified.

## 5.5 ELECTROMAGNETIC

Electromagnetic compatibility can be defined as the ability of each component in an integrated system to perform its design function without interfering with the performance of the design function of any other component in the system. The basic parameters which determine whether one component will interfere with the function of another are:

1. Level and bandwidth of signal which a component is capable of emitting (transmitter signal)
2. Level and bandwidth of signal to which a component is capable of responding (receiver sensitivity)
3. "Coincident time interval" or the occurrence of simultaneous operation of components whose parameters (Items 1 and 2) overlap
4. Amount of isolation between components.

To provide for an electromagnetic compatibility check between the experiments and the launch vehicle, the transmitter signal and the receiver sensitivity must be defined for the selected experiments. The assumption was made that no electromagnetic interference exists between the experiments that are ejected as separate satellites and the launch vehicle. It is recognized that isolation is not infinite for these ejected packages; however, since isolation is a function of frequency and distance, the separation distances considered in this study make the assumption valid. Because of this assumption, only the ten experiments that remain aboard the launch vehicle were analyzed for the electromagnetic compatibility parameters.

Each experiment is described by a narrowband transmitter signal, a broadband transmitter signal, a narrowband receiver sensitivity, and a broadband receiver sensitivity as shown in Figure 5-3 and Table 5-3. The narrowband signals and sensitivities are presented by a plot of signal level in decibels above a milliwatt versus frequency in megacycles; the broadband signals and sensitivities are presented by a plot of signal energy in decibels above a milliwatt per megacycle versus frequency in megacycles. These curves do not show the electromagnetic compatibility characteristics of each piece of equipment but show the composite characteristics of the whole package. The narrowband signal levels shown in Figure 5-3 were determined by an analysis of the emission spectrums of the UHF transmitter and the S-band telemetry contained in the experiments.

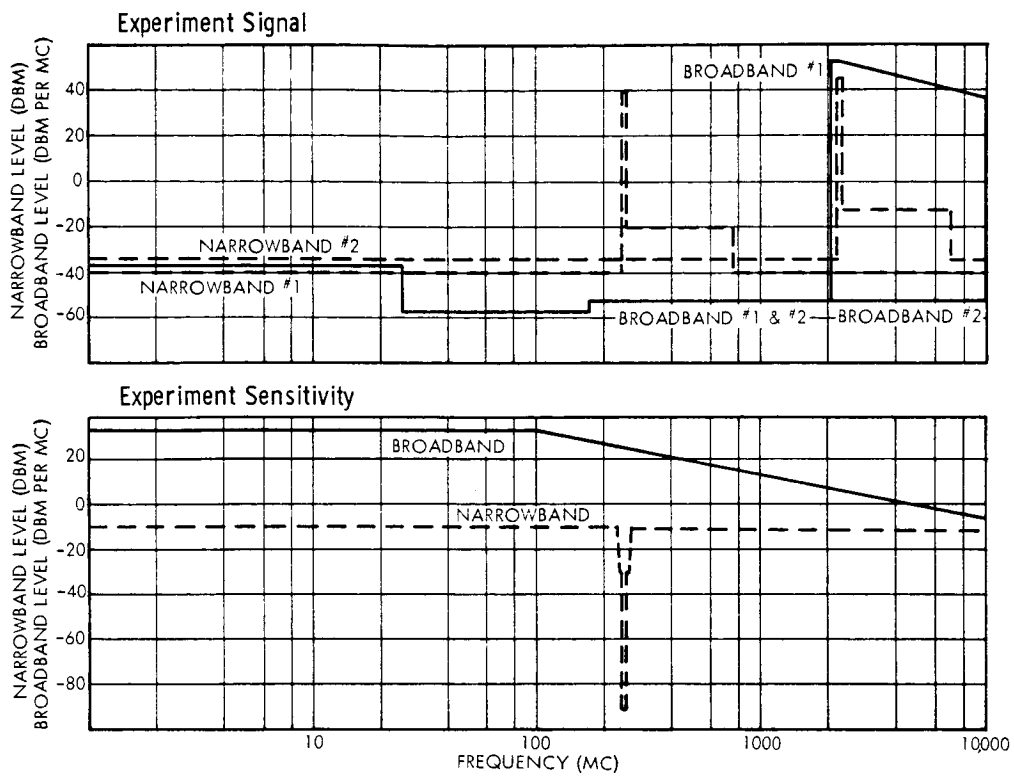

Figure 5-3 EXPERIMENT ELECTROMAGNETIC ENVIRONMENT

TABLE 5-3  
EXPERIMENT ELECTROMAGNETIC ENVIRONMENT

Applicable Curves	Experiments									
	MS -2	MS -3	MS -4	MS -5	SLG -1	SLG -2	SLG -4	SLG -5	M -2	OEA -1
NARROWBAND SIGNAL #1	✓	✓	✓	✓	✓	✓		✓		✓
NARROWBAND SIGNAL #2									✓	
BROADBAND SIGNAL #1	✓	✓	✓	✓		✓		✓	✓	
BROADBAND SIGNAL #2					✓		✓			✓
NARROWBAND SENSITIVITY	✓	✓	✓	✓	✓	✓		✓	✓	✓
BROADBAND SENSITIVITY	✓	✓	✓	✓	✓	✓	✓	✓	✓	✓

The broadband signals were based on the characteristics of S-band transponders and on emission limits outlined in the electromagnetic interference control specification MIL-I-6181D. The narrowband sensitivity level shown in Figure 5-3 was determined by the characteristics of the command receiver contained in the experiments. The broadband sensitivity was based on functional test specifications. Because these values were obtained by preliminary analysis, they should be considered only as approximations made for the purpose of the computer program development and checkout.

SECTION 6  
CONCEPTUAL DESIGN OF  
EXPERIMENTS

6.1 GENERAL

Experiment conceptual design drawings and mass and volume analyses were made for each of the 30 experiments selected for use in this study. This design effort was necessary to:

1. Provide mass and volume data for each experiment
2. Determine typical characteristics of the six scientific and technological categories
3. Ensure design feasibility
4. Interpret the experiment/launch vehicle interface.

A typical conceptual design drawing and a typical mass summary are shown in Figure 6-1 and Table 6-1; the remainder of the drawings and mass summaries are included in Appendices A and B of this volume. In these drawings, the experiment-package shape, the arrangement of components, the total package volume, the volume of basic components, the total package mass, and the critical-component shape are shown.

In establishing configuration designs for the 30 experiments, primary emphasis was placed on self-contained packages; that is, no consideration was given to the support capabilities of on-board equipment or to the sharing of subsystems with other experiments. However, to obtain a broader spectrum of data for use in the computer program checkout, the pertinent characteristics of certain vehicle-dependent experiments were also formulated. A vehicle-dependent experiment is defined as a self-contained experiment exclusive of power and communications systems; it is indicated by an "A" after the basic-experiment number. The experiments that were considered on both a self-contained and a vehicle-dependent basis are those ten experiments which remain aboard the launch vehicle and are not ejected as separate satellites.



NOTES

1. VOLUME (IN<sup>3</sup>)  
 BASIC COMPONENTS 7427  
 INSTALLED 17,400  
 2. TOTAL MASS (LBS) 233  
 CRITICAL COMP SHAPE 14.0 DIA x 18.5  
 3. ENTIRE EXPERIMENT PACKAGE TO BE  
 4. EJECTED FROM LAUNCH VEHICLE INTO  
 EARTH ORBIT.

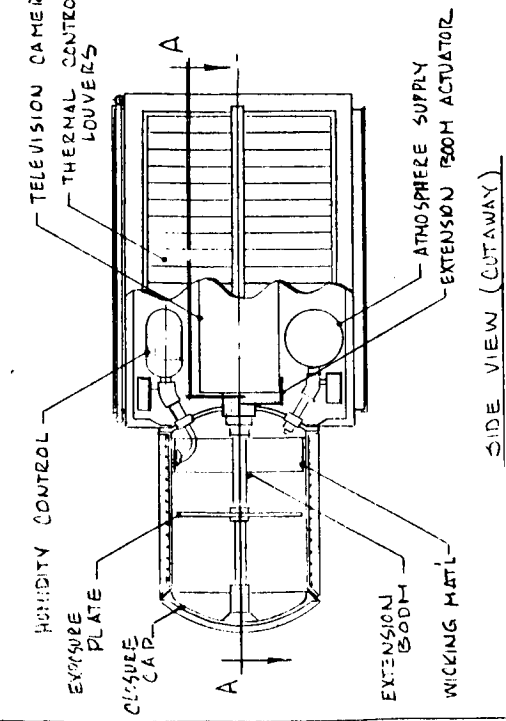
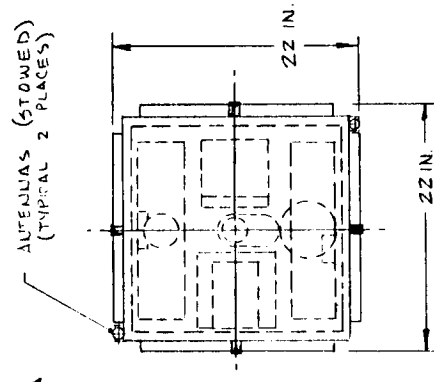
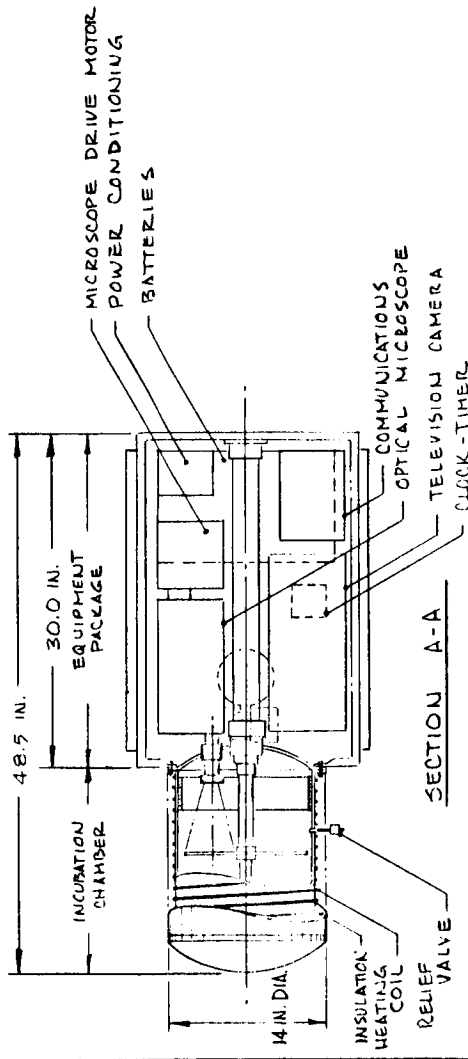

EXPERIMENT M-1  
 SOFT CAPTURE, ENUMERATION AND  
 IDENTIFICATION OF SPACE-BORNE  
 MICROORGANISMS  
 1/10 SCALE G.F. GIBSON 10-8-65

Figure 6-1 EXPERIMENT M-1 CONCEPTUAL DESIGN DRAWING

Table 6-1 MASS SUMMARY EXPERIMENT M-1

<u>ITEM</u>		<u>MASS-LBS</u>
Experiment Equipment		40.0
Exposure Plates	5.0	
Microscope	20.0	
Drive Motor	5.0	
Television Cameras	10.0	
Power Supply		94.0
Batteries	82.0	
Power Conditioning	6.0	
Distribution	6.0	
Communications		16.6
Command Receiver	2.5	
S-Band Transponder	4.5	
S-Band Telemetry	7.0	
Antennas	2.6	
Environmental Control		26.0
Satellite Structure		<u>36.0</u>
TOTAL MASS EXPERIMENT PACKAGE		212.6
Installation and Ejection Hardware		<u>20.0</u>
TOTAL INSTALLED MASS		232.6

## 6.2 EXPERIMENT CHARACTERISTICS

The purpose of the design effort was to obtain the experiment characteristics needed to formulate and check out the computer programs. The essential experiment characteristics that were obtained from the conceptual design effort are summarized in this section.

### 6.2.1 Deployment Requirements

During a mission, certain experiment requirements must be met in order to ensure success of any experiment. Of particular interest to this study are those requirements that are contingent on proper installation of the experiment relative to the launch vehicle. These experiment requirements include exposure to vacuum, extension of an experiment component from the launch vehicle, separation of the experiment payload from the launch vehicle, and separation of a data-recovery capsule. In order to fully describe

these requirements for each experiment, six deployment modes, Mode 0 through Mode 5, were defined as shown in Figure 6-2. The modes were devised so that it is necessary to describe each experiment by only one deployment mode. A list of the 30 experiments and their required deployment modes is presented in Table 6-2. By the assignment of acceptable deployment modes to the potential payload locations, experiment/vehicle location compatibility checks can easily be made.

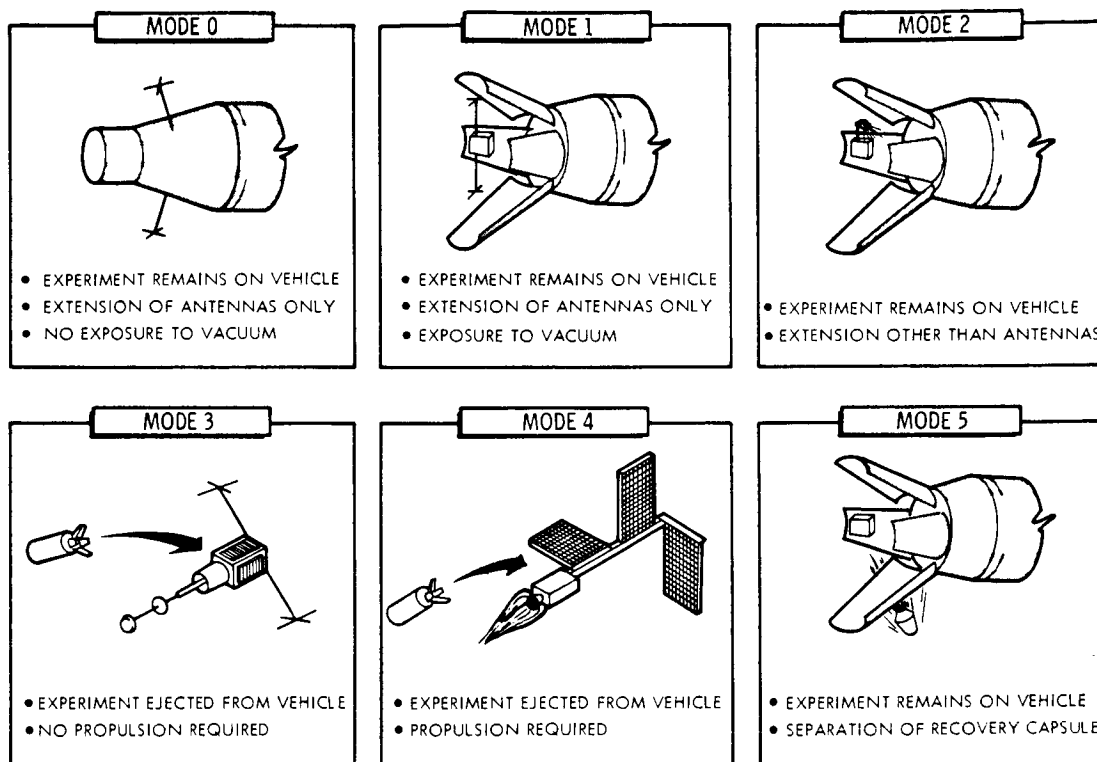

Figure 6-2 DEPLOYMENT MODE DEFINITION

### 6.2.2 Mass

A summary of the masses of the self-contained and vehicle-dependent experiments is presented in Table 6-3. For those experiments that are ejected from the launch vehicle as separate satellites, two sets of data are given. The total installed mass is the total experiment mass installed on the launch vehicle. The total mass of separate satellite is the total mass of the satellite after separation from the launch vehicle. The mass of the vehicle-dependent experiments was obtained by subtracting the communication and power-supply mass from the total mass of the basic self-contained experiment.

TABLE 6-2  
EXPERIMENT DEPLOYMENT MODES

Experiment	Mode	Experiment	Mode
SDT-1	3	SLG-1 & -1A	5
SDT-2	4	SLG-2 & -2A	0
SDT-3	3	SLG-3	3
SDT-4	3	SLG-4 & -4A	5
SDT-5	4	SLG-5 & -5A	0
MS-1	3	M-1	3
MS-2 & -2A	1	M-2 & -2A	0
MS-3 & -3A	1	M-3	3
MS-4 & -4A	1	M-4	3
MS-5 & -5A	2	M-5	3
MI-1	3	OEA-1 & -1A	2
MI-2	3	OEA-2	3
MI-3	3	OEA-3	4
MI-4	3	OEA-4	3
MI-5	3	OEA-5	3

TABLE 6-3  
EXPERIMENT MASS SUMMARY

Self-Contained Experiments					
EXPERIMENT	TOTAL INSTALLED MASS (LBS)	TOTAL MASS OF SEPARATE SATELLITE (LBS)	EXPERIMENT	TOTAL INSTALLED MASS (LBS)	TOTAL MASS OF SEPARATE SATELLITE (LBS)
SDT-1	1031	937	SLG-1	191	--
SDT-2	58	53	SLG-2	195	--
SDT-3	682	636	SLG-3	713	648
SDT-4	487	443	SLG-4	201	--
SDT-5	440	400	SLG-5	153	--
MS-1	795	723	M-1	233	213
MS-2	103	--	M-2	165	--
MS-3	154	--	M-3	205	186
MS-4	173	--	M-4	135	123
MS-5	135	--	M-5	230	209
MI-1	1082	984	OEA-1	308	--
MI-2	896	815	OEA-2	312	284
MI-3	1434	1310	OEA-3	378	344
MI-4	798	730	OEA-4	401	365
MI-5	2812	2562	OEA-5	691	632
Vehicle-Dependent Experiments					
MS-2A	50	--	SLG-2A	86	--
MS-3A	60	--	SLG-4A	167	--
MS-4A	102	--	SLG-5A	69	--
MS-5A	74	--	M-2A	119	--
SLG-1A	160	--	OEA-1A	121	--

### 6.2.3 Volume

A summary of the volumes, packaging factors, and critical-component sizes of the self-contained and vehicle-dependent experiments is presented in Table 6-4. The basic-component volume is the sum of the volumes of the individual components within the experiment package, and the installed volume is the minimum volume for practical installation. For the self-contained experiments, this installation volume was obtained from an analysis of the conceptual-design drawings. For the vehicle-dependent experiments, the installation volume was obtained by multiplying the basic-component volume by the packaging factor of that particular self-contained experiment. The packaging factor is defined as the ratio of the installed volume to the basic-component volume. The critical component is an envelope of such size and shape that it will contain, in turn, each of the undistortable components in the experiment package. The critical component, then, can be either the largest undistortable component in the experiment or a composite of several undistortable components.

### 6.3 CONFIGURATION DESCRIPTION

The conceptual designs of the 30 experiments are summarized on the following pages by brief descriptions, isometric drawings, and mass and volume statements. The experiments that are shown with the Earth and sky in the background are designed to be ejected as separate satellites; those shown with no background are designed for operation aboard the launch vehicle.

**TABLE 6-4  
EXPERIMENT VOLUME SUMMARY**

<b>Self-Contained Experiments</b>				
<b>EXPERIMENT</b>	<b>BASIC COMPONENT VOLUME (IN<sup>3</sup>)</b>	<b>INSTALLED VOLUME (IN<sup>3</sup>)</b>	<b>PACKAGING FACTOR</b>	<b>CRITICAL COMPONENT DIMENSIONS (IN)</b>
SDT-1	50,900	122,000	2.40	30.0 x 30.0 x 24.0
SDT-2	2,504	3,689	1.47	6.0 x 6.0 x 36.0
SDT-3	25,803	72,900	2.83	21.0 DIA x 42.0
SDT-4	22,465	47,595	2.12	20.0 DIA x 48.0
SDT-5		30,349		27.8 DIA x 50.0
MS-1	46,200	73,500	1.59	36.0 DIA x 48.0
MS-2	1,827	2,988	1.64	10.0 x 12.0 x 12.0
MS-3	2,809	3,750	1.33	3.0 x 10.0 x 14.0
MS-4	4,344	5,500	1.27	4.0 x 8.5 x 14.0
MS-5	3,350	4,650	1.39	8.3 x 17.0 x 10.0
MI-1	31,670	81,200	2.56	44.0 x 22.0 x 31.0
MI-2	21,000	39,468	1.88	30.0 x 15.0 x 20.0
MI-3	98,000	139,000	1.42	12.0 x 60.0 x 80.0
MI-4	27,110	79,083	2.92	15.0 DIA x 51.0
MI-5	200,903	469,800	2.34	44.0 x 60.0 x 132.0
SLG-1	7,338	13,500	1.84	18.0 DIA x 25.0
SLG-2	3,450	7,862	2.28	17.0 x 11.0 x 6.0
SLG-3	43,950	102,993	2.34	33.5 DIA x 42.0
SLG-4	4,720	10,090	2.14	18.0 DIA x 25.0
SLG-5	5,130	7,100	1.38	10.0 x 10.0 x 13.0
M-1	7,427	17,400	2.34	14.0 DIA x 18.5
M-2	3,218	6,916	2.15	16.0 x 8.0 x 8.0
M-3	3,500	8,700	2.49	7.0 x 7.0 x 16.0
M-4	4,117	13,696	3.33	20.0 x 20.0 x 12.0
M-5	4,299	8,757	2.04	8.0 x 11.0 x 16.0
OEA-1	7,333	11,600	1.58	5.0 x 11.0 x 13.0
OEA-2	7,700	19,600	2.55	13.5 x 15.2 x 21.0
OEA-3	6,838	17,512	2.56	5.0 x 11.0 x 14.0
OEA-4	8,818	22,140	2.51	18.0 DIA x 25.0
OEA-5	12,456	31,870	2.56	15.0 DIA x 20.0
<b>Vehicle-Dependent Experiments</b>				
MS-2A	972	1,594	1.64	10.0 x 12.0 x 12.0
MS-3A	1,229	1,635	1.33	30.0 x 10.0 x 14.0
MS-4A	2,998	3,807	1.27	4.0 x 8.5 x 14.0
MS-5A	2,004	2,786	1.39	8.3 x 17.0 x 10.0
SLG-1A	6,914	12,722	1.84	18.0 DIA x 25.0
SLG-2A	1,620	3,694	2.28	17.0 x 11.0 x 6.0
SLG-4A	4,220	9,031	2.14	18.0 DIA x 25.0
SLG-5A	3,760	5,226	1.38	10.0 x 10.0 x 13.0
M-2A	2,488	5,349	2.15	16.0 x 8.0 x 8.0
OEA-1A	4,294	6,785	1.58	5.0 x 11.0 x 13.0

### 6.3.1 Category I - Systems Development and Test

All of the experiments in Category I are designed to be ejected as separate satellites. One experiment, the Energetic Particles Explorer, is an existing Explorer satellite and, therefore, is considered a fixed-geometry configuration. The experiment masses range from 58 pounds for SDT-2 to 1,031 pounds for SDT-1. For the same experiments, the required volumes are 3,689 and 122,000 cubic inches, respectively.

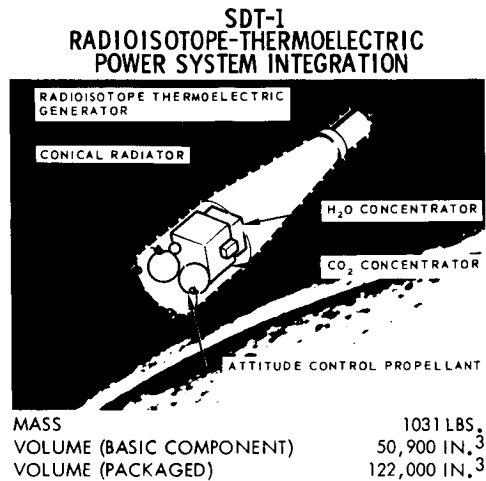

Figure 6-3 EXPERIMENT SDT-1 CONFIGURATION

#### 6.3.1.1 Experiment SDT-1

The objective of Experiment SDT-1 is the integration of an isotope power supply with components of an advanced life support system that will utilize the waste heat from the power system (Figure 6-3). The experiment satellite consists of a radioisotope thermoelectric generator, a conical thermal radiator, and an equipment package. The equipment package contains two life support components: a CO<sub>2</sub> concentrator and a water purification still. The package also includes communication, power, data automation, environmental control, attitude control, and propulsion systems.

#### 6.3.1.2 Experiment SDT-2

The objective of Experiment SDT-2 is to determine the response of cadmium-sulfide and other thin-film photovoltaic cells to the combined effects of free space environments (Figure 6-4). The experiment package consists of an equipment compartment, three thin-film solar panels, and a propulsion system. The equipment compartment contains the experiment sensors and communications subsystems. After the experiment is ejected from the launch vehicle, the propulsion system is used to achieve the desired orbit. The solar panels and the antenna are then erected into the operating configuration.

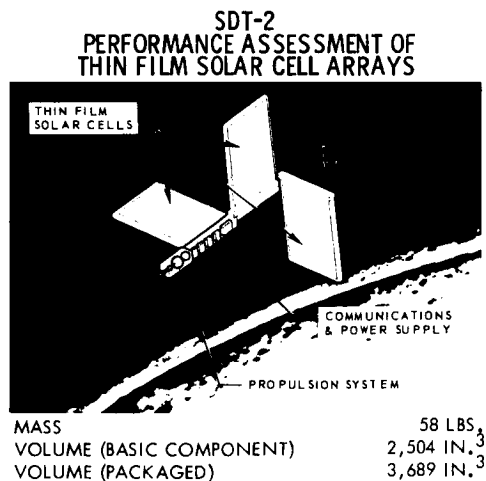

Figure 6-4 EXPERIMENT SDT-2 CONFIGURATION

SDT-3  
 PERFORMANCE ASSESSMENT OF SPACECRAFT  
 NAVIGATION, GUIDANCE AND CONTROL  
 HARDWARE AND TECHNIQUES

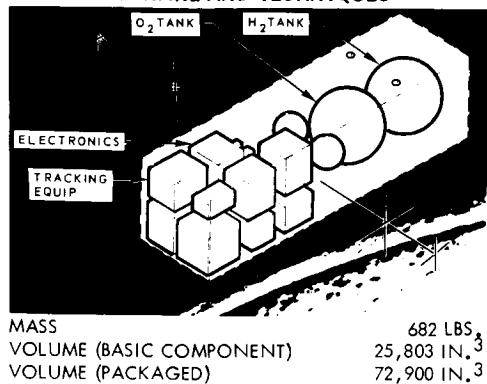

Figure 6-5 EXPERIMENT SDT-3 CONFIGURATION

6.3.1.3 Experiment SDT-3

The objective of Experiment SDT-3 is to investigate the feasibility of a self-contained space navigation system (Figure 6-5). The basic experiment package contains the experiment sensors (electromagnetic sensors, inertial measurement unit, and on-board navigation system), communications, power, and environmental control. Six attitude-control jets are mounted on the aft end to provide pitch, yaw, and roll control. A thermal radiator is installed on two surfaces of the experiment to provide for heat dissipation. Two turnstile antennas are extended from the satellite after it has separated from the launch vehicle.

6.3.1.4 Experiment SDT-4

SDT-4  
 CRYOGENIC PROPELLANT STORAGE  
 SYSTEM PERFORMANCE

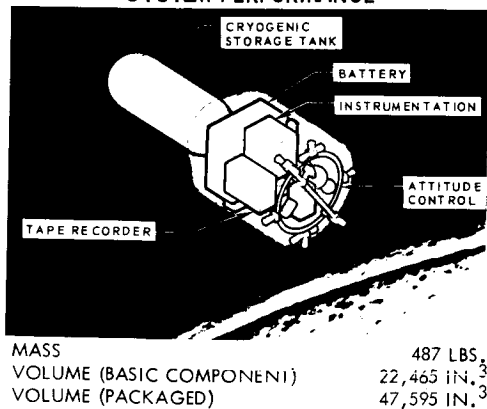
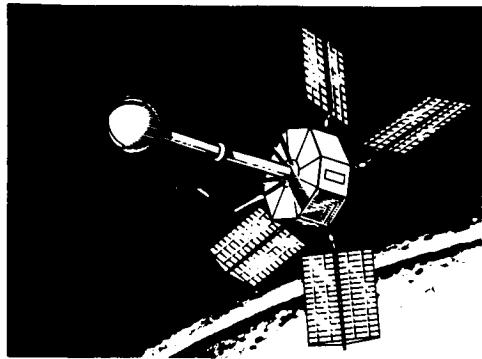

Figure 6-6 EXPERIMENT SDT-4 CONFIGURATION

The objective of Experiment SDT-4 is to evaluate the effectiveness of superinsulation and ullage orientation in cryogenic propellant-storage systems (Figure 6-6). The experiment contains a cylindrical cryogenic storage tank which is 15 inches in diameter and 40 inches long and covered with superinsulation. Attached to this tank is another cylindrical section containing the experiment sensors and the communications, data handling, power, and attitude control systems. Two antennas are extended from the experiment package after it has separated from the launch vehicle.



SDT-5  
ENERGETIC PARTICLES  
EXPLORER



MASS  
VOLUME (PACKAGED)

440 LBS.  
30,300 IN.<sup>3</sup>

Figure 6-7 EXPERIMENT SDT-5 CONFIGURATION

6.3.1.5 Experiment SDT-5

The objective of Experiment SDT-5 is to provide a portion of the boost trajectory for an existing unmanned satellite, thereby reducing the expense of individual satellite launches (Figure 6-7). The Energetic Particles Explorer is used to provide data on high-energy particles. It consists of an octagonal platform atop a truncated cone. Four solar panels are extended from the sides after the satellite has separated from the launch vehicle. A magnetometer is mounted on a 34-inch tube on top of the spacecraft. A propulsion system has been added to the spacecraft to enable it to reach the required orbit.

6.3.2 Category II - Materials and Structures

Experiment MS-1, The Degradation of Organic Materials in Space Environment, is the only experiment in this category to be ejected as a separate satellite. It also has the largest mass (795 pounds) and volume (73,500 cubic inches). The remainder of the experiments are designed to remain aboard the launch vehicle. Their masses range from 103 to 173 pounds and their volumes from 2,988 to 5,500 cubic inches.

MS-1  
DEGRADATION OF ORGANIC MATERIALS  
IN SPACE ENVIRONMENT

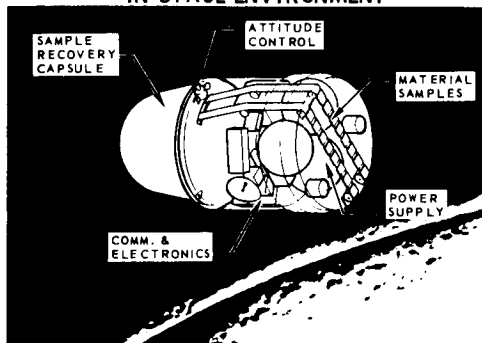

MASS  
VOLUME (BASIC COMPONENT)  
VOLUME (PACKAGED)

795 LBS.  
46,200 IN.<sup>3</sup>  
73,500 IN.<sup>3</sup>

Figure 6-8 EXPERIMENT MS-1 CONFIGURATION

6.3.2.1 Experiment MS-1

The objective of Experiment MS-1 is to determine the combined effects of space radiation, space vacuum, and temperature upon organic materials (Figure 6-8). The satellite is composed of a cylindrical section containing experiment sensors and communication, data automation, attitude control, power, and environmental control systems. The material samples are attached to a belt supported by a series of rollers. The samples can be exposed or retracted as directed by the programmer. After sufficient exposure, time, the samples are wound into a

modified Discoverer data-recovery capsule for return to Earth.

### 6.3.2.2 Experiment MS-2

The objective of Experiment MS-2 is to investigate the stability and potential coagulation of liquid-metal films under the effects of hard vacuum and weightlessness (Figure 6-9). The experiment package consists of a liquid film sensor and related communications, power, and data automation equipment. Because of the relatively short lifetime required of the experiment, it can remain aboard the launch vehicle. However, the liquid film sensor must be exposed to the space environment, and UHF and S-band antennas must be extended from the launch vehicle during experiment operation.

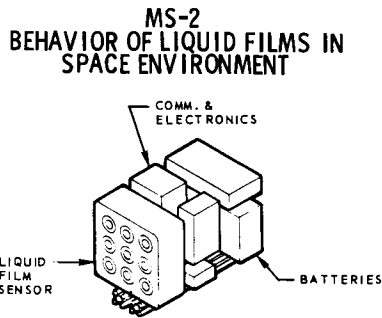

MASS	103 LBS.
VOLUME (BASIC COMPONENT)	1,827 IN. <sup>3</sup>
VOLUME (PACKAGED)	2,988 IN. <sup>3</sup>

Figure 6-9 EXPERIMENT MS-2 CONFIGURATION

### 6.3.2.3 Experiment MS-3

The objective of Experiment MS-3 is to determine the vaporization rate of molten metals at the ambient pressures of lower orbits (Figure 6-10). The experiment contains a molten metal sensor and several support systems. Although the experiment is not ejected as a separate satellite, the molten metal must be exposed to the space environment. Vaporization is measured by the interruption of electrical contacts in the wall of the receptacle that contains the sample metal. Antennas must be extended from the vehicle during experiment operation.

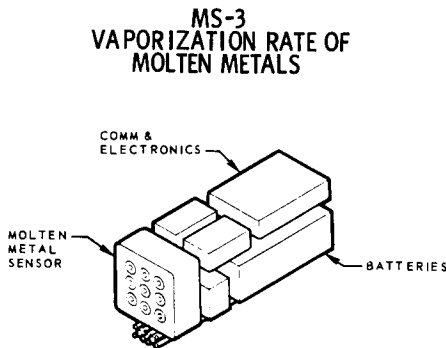

MASS	154 LBS.
VOLUME (BASIC COMPONENT)	2,809 IN. <sup>3</sup>
VOLUME (PACKAGED)	3,750 IN. <sup>3</sup>

Figure 6-10 EXPERIMENT MS-3 CONFIGURATION

**MS-4  
COLD WELDING OF METALS  
IN SPACE ENVIRONMENT**

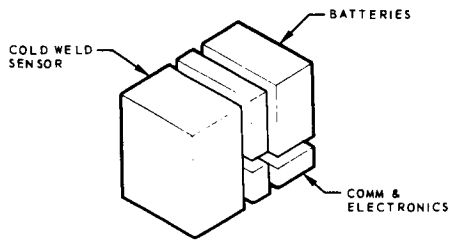

MASS	173 LBS.
VOLUME (BASIC COMPONENT)	4,344 IN. <sup>3</sup>
VOLUME (PACKAGED)	5,500 IN. <sup>3</sup>

Figure 6-11 EXPERIMENT MS-4 CONFIGURATION

**6.3.2.4 Experiment MS-4**

The objective of Experiment MS-4 is to investigate the feasibility of utilizing the seizing of metal surfaces in high vacua for producing welded joints (Figure 6-11). The experiment contains a sensor to measure simple contact welding. Another sensor measures the welding between surfaces of a disc and a slowly rotating cylinder. Magnets are used to separate the specimens. The required power input to the magnet is a measure of the surface adhesion. Communication, power, data automation, and environmental control systems are included in the experiment package.

**MS-5  
SPRAY COATING AND  
SURFACE CONTAMINATION**

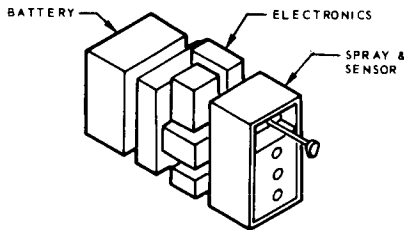

MASS	135 LBS.
VOLUME (BASIC COMPONENT)	3,350 IN. <sup>3</sup>
VOLUME (PACKAGED)	4,650 IN. <sup>3</sup>

Figure 6-12 EXPERIMENT MS-5 CONFIGURATION

**6.3.2.5 Experiment MS-5**

The objective of Experiment MS-5 is to determine the feasibility of surface-spraying in space for coating space assemblies and to determine the extent of contamination of vehicle surfaces with particles or vapors produced close to the surfaces (Figure 6-12). The primary-experiment package contains a spraying mechanism and a test plate equipped with devices to measure the spray coating on the test plate. Two other spray sensors are located in other areas of the vehicle to determine contamination from the spray. The experiment package also contains communication, data automation, and power systems.

**6.3.3 Category III - Multispectral Imagery of the Earth and Orbiting Objects**

Because of the long-lifetime requirements, all of the experiments in Category III were designed as separate satellites. The synoptic Earth Cartography experiment has the largest mass (2,812 pounds) and

volume (469,800 cubic inches). The masses of the other experiments vary between 798 and 1,434 pounds, and the volumes vary between 39,468 and 139,000 cubic inches.

### 6.3.3.1 Experiment MI-1

The objective of Experiment MI-1 is to obtain multispectral data of selected areas of the surface of the Earth (Figure 6-13). These data consist of aerial photographs and spectral radiometric data that will be obtained simultaneously. The experiment satellite consists of four cameras, a spectrometer, and a V/H sensor plus the required support systems (communications, data automation, power, attitude control, and environmental control). Two data-recovery capsules are required for film retrieval.

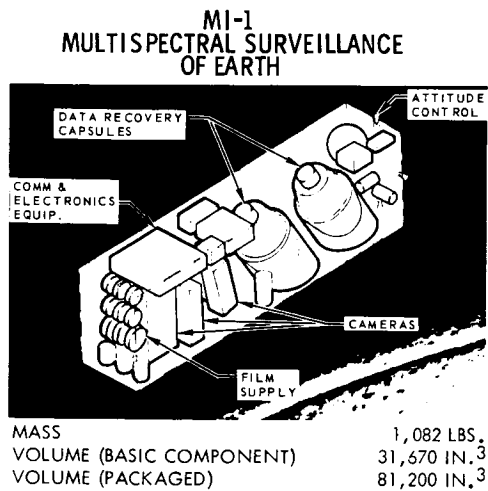

Figure 6-13 EXPERIMENT MI-1 CONFIGURATION

### 6.3.3.2 Experiment MI-2

The objective of Experiment MI-2 is the development and test of a satellite-borne infrared line scanner (Figure 6-14). The three primary items of equipment are an infrared line scanner, a video tape recorder, and a power supply. The infrared line scanner is similar in concept to existing line scanners used in reconnaissance aircraft. The satellite also includes an attitude control system and a communications system. An S-band antenna and a UHF antenna are extended from the satellite after it has separated from the launch vehicle.

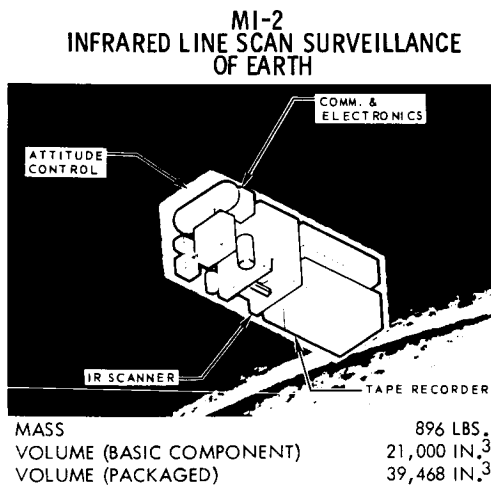

Figure 6-14 EXPERIMENT MI-2 CONFIGURATION

### 6.3.3.3 Experiment MI-3

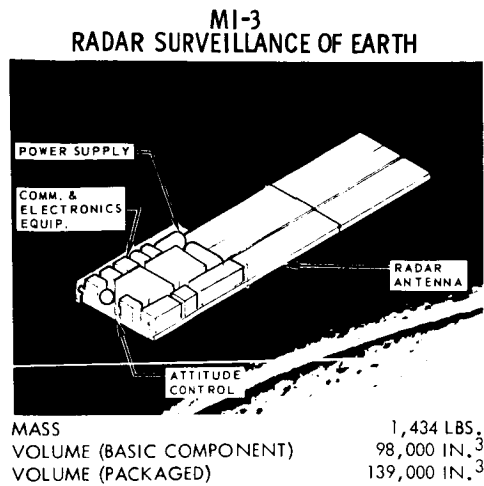

Figure 6-15 EXPERIMENT MI-3 CONFIGURATION

The objective of Experiment MI-3 is to obtain high-resolution radar images of the Earth's surface by means of a satellite-borne, coherent data-processing, side-looking radar (Figure 6-15). The side-looking radar antenna is designed to be folded into three segments for packaging aboard the launch vehicle. After ejection from the launch vehicle, the antenna is deployed as shown. The satellite contains equipment to process the radar image data during flight and to telemeter this information to a ground station.

### 6.3.3.4 Experiment MI-4

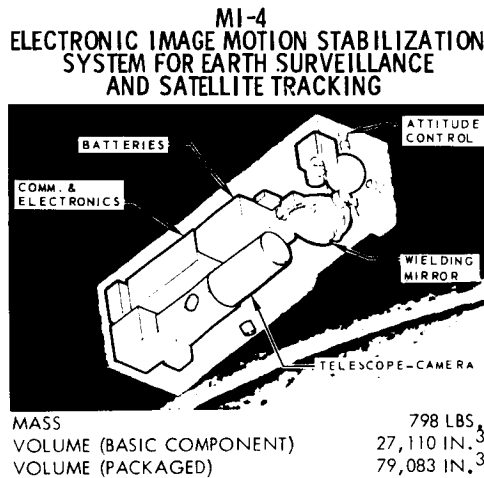
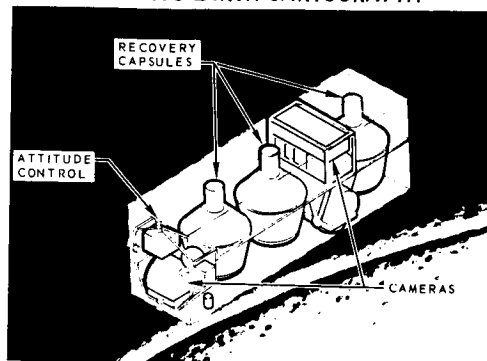

Figure 6-16 EXPERIMENT MI-4 CONFIGURATION

The objective of Experiment MI-4 is to obtain high-resolution imagery of either selected areas of the Earth's surface or satellites which are in the vicinity of the experiment satellite (Figure 6-16). The experiment sensor is a telescope-camera with an image motion stabilization capability based on optical feedback. A wedding mirror is provided to enable the line of sight to be pointed at any direction within a  $\pm 45$ -degree cone. The satellite also contains power, data automation, environmental control, attitude control, and communication systems.

MI-5  
SYNOPTIC EARTH CARTOGRAPHY



MASS	2,812 LBS.
VOLUME (BASIC COMPONENT)	200,903 IN. <sup>3</sup>
VOLUME (PACKAGED)	469,800 IN. <sup>3</sup>

Figure 6-17 EXPERIMENT MI-5 CONFIGURATION

### 6.3.3.5 Experiment MI-5

The objective of Experiment MI-5 is to obtain wide-area stereo photography, of cartographic quality, of selected Earth areas (Figure 6-17). Three identical frame cameras are installed in a transverse fan; one camera is vertical and the other two are left and right side oblique. The side oblique cameras are packaged in the vertical position and pivot to the oblique position during experiment operation. The satellite also includes attitude control, data automation, power, and communication systems. Because of the mass of the film to be retrieved, three data-recovery capsules are required.

### 6.3.4 Category IV - Solid/Liquid/Gas Behavior

Only one experiment in Category IV, the Formation of Single Crystals, was designed to be ejected as a separate satellite. The remaining four are contained aboard the launch vehicle for the entire mission. Physical data recovery by a recoverable capsule is used in the ejected experiment and in two of the contained experiments. Masses of the contained experiments vary from 153 to 201 pounds; the ejected experiment has a mass of 713 pounds. The volume requirements range from approximately 7,100 to 13,500 cubic inches for the contained experiments; for the ejected experiment, the volume requirement is 102,993 cubic inches.

**SLG-1  
BOILING IN ZERO-G ENVIRONMENT**

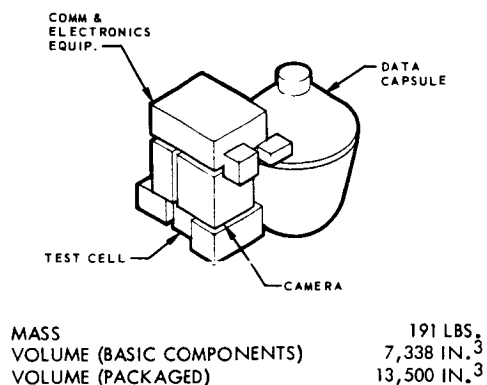

Figure 6-18 EXPERIMENT SLG-1 CONFIGURATION

**6.3.4.1 Experiment SLG-1**

The objective of Experiment SLG-1 is to measure the heat transfer rates from a solid heater to a liquid-vapor mixture and to study the details of the heat transfer mechanism (Figure 6-18). The experiment sensor consists of a test cell containing a liquid-vapor mixture. High-speed movies are taken of bubble formations when the mixture is heated. A tape recorder is provided to record temperature and pressure data. Physical recovery of the film and tape is achieved by the use of a data-recovery capsule. A UHF antenna must be extended from the launch vehicle during experiment operation.

**SLG-2  
NUCLEATE CONDENSATION  
IN ZERO-GRAVITY**

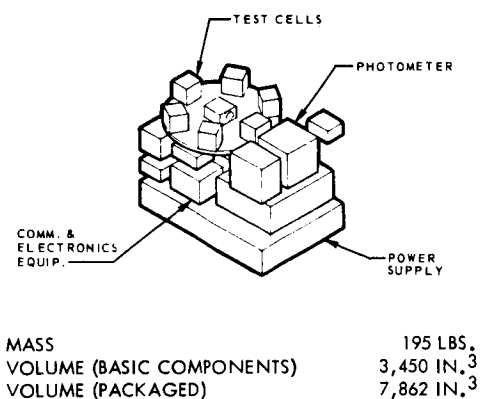

Figure 6-19 EXPERIMENT SLG-2 CONFIGURATION

**6.3.4.2 Experiment SLG-2**

The objective of Experiment SLG-2 is to study the initiation conditions for nucleate condensation and the concentration distributions of the resulting 2-phase mixture (Figure 6-19). Six transparent test cells containing a pure fluid are mounted on a turntable with a light fixed in the center. The fluid is heated to cause vaporization and then cooled to cause condensation. The condensation process is monitored for each cell by a light-scattering technique that uses a photometer. Communications, power, and data handling equipment are included in the experiment package.

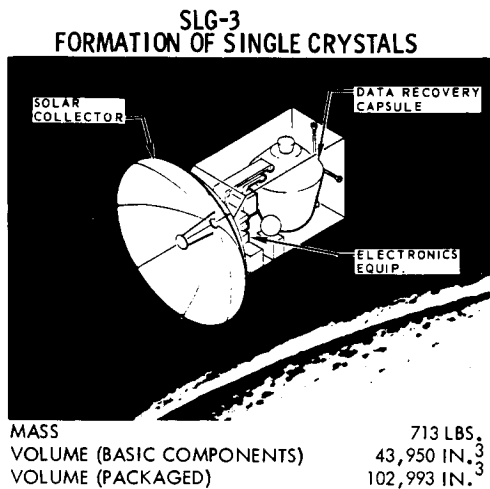

Figure 6-20 EXPERIMENT SLG-3 CONFIGURATION

### 6.3.4.3 Experiment SLG-3

The objective of Experiment SLG-3 is to form a single crystal that is free from the deleterious effects of gravity (Figure 6-20). A number of test cells are mounted on a belt and pulley system. The cells are positioned, one at a time, at the focal point of a solar collector to melt the material within the cells. At the completion of the experiment these cells, along with tape from the recorder, are fed into a data-recovery capsule for physical recovery. The collector is constructed from a number of petals which can be unfurled in space to form an efficient parabolic shape.

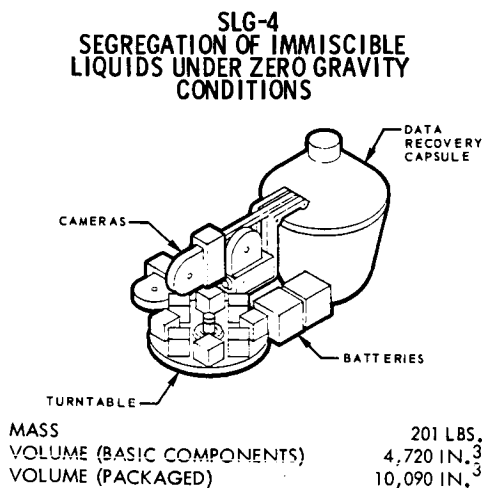

Figure 6-21 EXPERIMENT SLG-4 CONFIGURATION

### 6.3.4.4 Experiment SLG-4

The objective of Experiment SLG-4 is to observe the migration and coalescence of liquid droplets in the absence of gravity forces (Figure 6-21). Eight test cells containing two immiscible liquids are mounted on a turntable. The turntable is used to agitate the liquids and to position the cells so that they can be photographed by three mutually perpendicular cameras. The film from these cameras is fed into a data-recovery capsule for physical film retrieval. A power supply, a communications system, and an environmental control system are included in the package.



SLG-5  
ZERO-G COMBUSTION

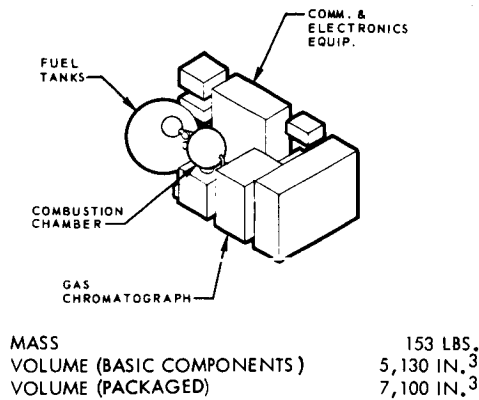

Figure 6-22 EXPERIMENT SLG-5 CONFIGURATION

6.3.4.5 Experiment SLG-5

The objective of Experiment SLG-5 is to observe the time-dependent behavior of fuel droplets burning in zero-g condition (Figure 6-22). The experiment contains a combustion chamber in which fuel droplets will be ignited in a given amount of oxidizer. A gas chromatograph is provided to monitor the combustion process. Communications, power, and environmental control system are included in the experiment package. Antennas must extend from the package during experiment operation.

6.3.5 Category V - Microorganisms

Four of the experimental payloads in Category V are designed to be ejected from the launch vehicle as separate orbiting satellites. Experiment M-2 is the only one designed to be contained in the launch vehicle. The total mass requirements for this category are all between 135 pounds and 233 pounds. Volume requirements vary from 6,916 to 17,400 cubic inches.

M-1  
SOFT CAPTURE, ENUMERATION AND  
IDENTIFICATION OF SPACE - BORNE  
MICROORGANISMS

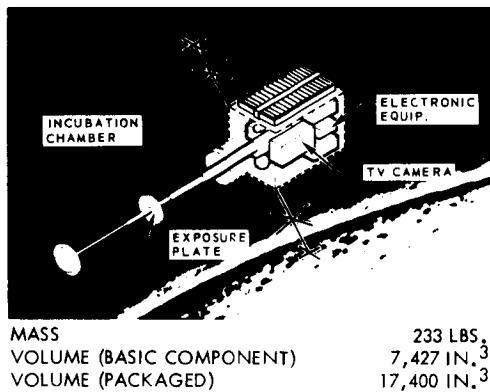
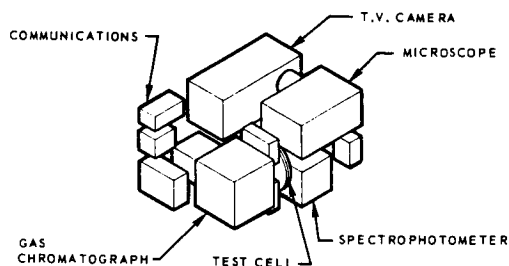

Figure 6-23 EXPERIMENT M-1 CONFIGURATION

6.3.5.1 Experiment M-1

The objective of Experiment M-1 is to capture and to cultivate anaerobic and aerobic life forms existing in space at orbital altitudes (Figure 6-23). The satellite is composed of an incubation chamber and an equipment package. During the capture operation, an exposure plate is extended from the incubation chamber by an extension boom. After the capture operation, the exposure plate is retracted into the incubation chamber for scanning by an optical microscope. Thermal control louvers are mounted on the surface of the satellite to provide for heat dissipation.

**M-2**  
**EFFECTS OF SPACE FLIGHT ON**  
**MORPHOLOGY, GROWTH, AND LIQUID/GAS**  
**SEPARATION IN MICROORGANISMS**



MASS	165 LBS.
VOLUME (BASIC COMPONENT)	3,218 IN. <sup>3</sup>
VOLUME (PACKAGED)	6,916 IN. <sup>3</sup>

Figure 6-24 EXPERIMENT M-2 CONFIGURATION

6.3.5.2 Experiment M-2

The objective of Experiment M-2 is to measure the effects of space flight environments on cell proliferation of coliform bacterium (Figure 6-24). The cultures are incubated in a suitable medium and contained in a transparent test cell. The test cell is mounted so that it can be rotated in front of a microscope and a spectrometer. A gas chromatograph is used to measure CO<sub>2</sub> evolved from metabolism. Support systems contained in the experiment package include communications, environmental control, power, and data handling.

**M-3**  
**GENETIC EFFECTS IN MICROORGANISMS**  
**AND MUTATION RATE IN EXTENDED**  
**SPACE FLIGHT CONDITIONS**

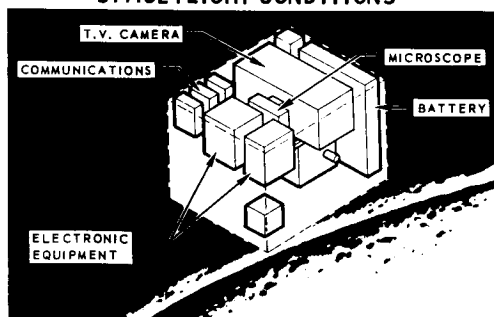

MASS	205 LBS.
VOLUME (BASIC COMPONENT)	3,500 IN. <sup>3</sup>
VOLUME (PACKAGED)	8,700 IN. <sup>3</sup>

Figure 6-25 EXPERIMENT M-3 CONFIGURATION

6.3.5.3 Experiment M-3

The objective of Experiment M-3 is to cultivate a sufficient number of bacterial cells to determine the rate of mutation and the ability of the mutants to grow in the presence of antibiotics (Figure 6-25). The bacterial cells are contained in a test cell which can be positioned to allow for complete scanning by the microscope. A television camera is used in conjunction with the microscope to transmit the photographs to Earth stations. The experiment package also contains communications equipment, a power-supply, and an environmental-control system.

#### 6.3.5.4 Experiment M-4

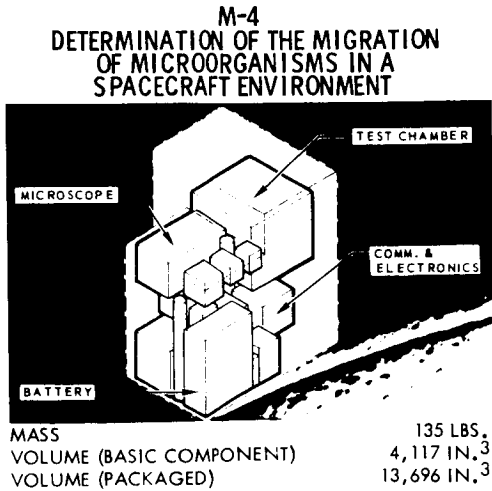

Figure 6-26 EXPERIMENT M-4 CONFIGURATION

The objective of Experiment M-4 is to determine the migration of fungal spores and bacterial cells under conditions of weightlessness (Figure 6-26). The test cell contains spores and cells that are allowed to circulate freely. Various incubation sites within the test cell are examined by means of a scanning, wide-angle, low-powered microscope lens equipped with a television camera. The experiment package also includes communication, data-automation, and power-supply systems.

#### 6.3.5.5 Experiment M-5

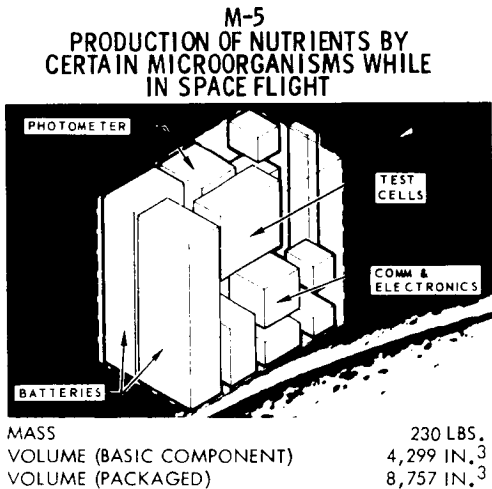

Figure 6-27 EXPERIMENT M-5 CONFIGURATION

The objective of Experiment M-5 is to determine the quality and quantity of growth of nutrient-requiring bacteria under space flight conditions (Figure 6-27). The primary experiment sensor is a test cell that contains a series of "U" tubes through which the test organisms pass. Turbidimetric measurements of organism growth are made by a photometer. Support systems included in the package are the following: power, communications, data automation, and environmental control. Antennas are extended from the satellite during experiment operation.

#### 6.3.6 Category VI - Observations of the Earth's Atmosphere, the Space Environment, and Astronomical Phenomena

As a result of the duration requirements for Category VI, only one experiment — OEA-1 — is designed to remain aboard the launch vehicle. The other four experiments are designed to be ejected as separate attitude-stabilized satellites for longer-duration missions. Mass and volume requirements for this category of experiments will vary from 308 to 691 pounds and from 11,600 to 31,870 cubic inches, respectively.

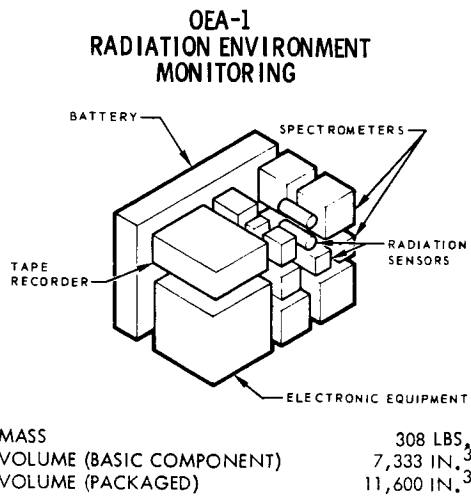

Figure 6-28 EXPERIMENT OEA-1 CONFIGURATION

### 6.3.6.1 Experiment OEA-1

The objective of Experiment OEA-1 is to measure both the radiation received by the crew and the external radiation environment (Figure 6-28). Film packs and pocket dosimeters are to be carried by the crew throughout the mission. Spectrometers and X-ray and neutron detectors are contained within the experiment package to record the environmental radiation. The data are stored on magnetic tape and relayed to Earth every orbit. Antennas must extend from the vehicle during experiment operation.

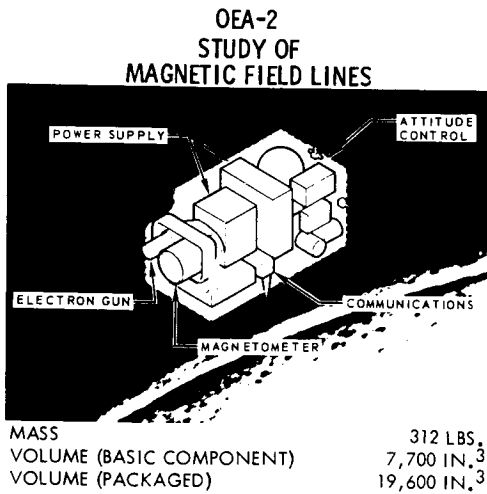
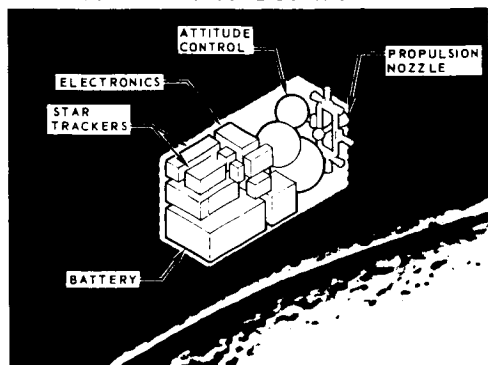

Figure 6-29 EXPERIMENT OEA-2 CONFIGURATION

### 6.3.6.2 Experiment OEA-2

The objective of Experiment OEA-2 is to study the geometry of the terrestrial magnetic field by measuring the paths followed by artificially injected electrons (Figure 6-29). An electron gun contained in the experiment is used to inject 1-millisecond-long pulses of 10-kilowatt electrons along a terrestrial magnetic field line. The gun is mounted on a gimbal assembly and oriented along the magnetic field lines by a flux-gate magnetometer. The experiment contains communications, attitude control, power, data automation, and environmental control systems.

OEA-3  
TEST OF PROTOTYPE STAR TRACKER



MASS	378 LBS.
VOLUME (BASIC COMPONENT)	6,838 IN. <sup>3</sup>
VOLUME (PACKAGED)	17,512 IN. <sup>3</sup>

Figure 6-30 EXPERIMENT OEA-3 CONFIGURATION

6.3.6.3 Experiment OEA-3

The objective of Experiment OEA-3 is to demonstrate the ability of a prototype star-tracker to lock on and track stars of the fourth magnitude when such stars are viewed near the horizon, beneath the airglow layer (Figure 6-30). Two star trackers are included in the experiment: a reference tracker to track a reference star about 20 degrees above the occulted star and the prototype tracker. A propulsion system is required to obtain the desired orbit. The satellite also contains power, attitude control, data automation, communications, and environmental control systems.

6.3.6.4 Experiment OEA-4

OEA-4  
COSMIC RAY EMULSION  
EXPERIMENTS

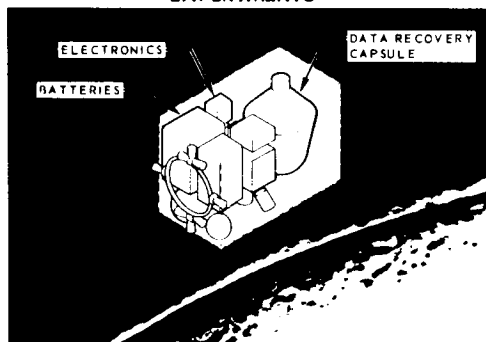

MASS	401 LBS.
VOLUME (BASIC COMPONENT)	8,818 IN. <sup>3</sup>
VOLUME (PACKAGED)	22,140 IN. <sup>3</sup>

Figure 6-31 EXPERIMENT OEA-4 CONFIGURATION

The objective of Experiment OEA-4 is to obtain a charge spectrum of the primary cosmic radiation and to measure the intensity and angular distribution at several times in the solar cycle (Figure 6-31). A stack of nuclear emulsion pellicles are stored in the data-recovery capsule and exposed during periods of pre-selected vehicle orientation. After the required exposure time, the emulsion is desensitized and returned to Earth in the recovery capsule. The experiment also contains power, communications, attitude control, and data automation systems.

OEA-5  
EMISSION LINE  
RADIOMETRY

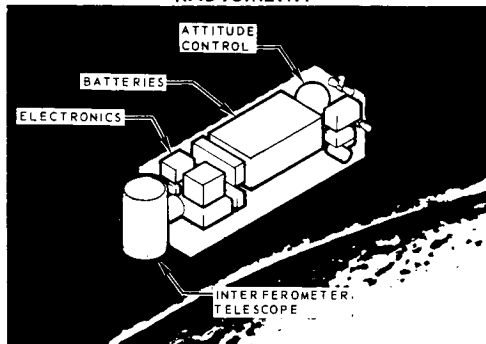

MASS	691 LBS.
VOLUME (BASIC COMPONENT)	12,456 IN. <sup>3</sup>
VOLUME (PACKAGED)	31,870 IN. <sup>3</sup>

Figure 6-32 EXPERIMENT OEA-5 CONFIGURATION

6.3.6.5 Experiment OEA-5

The objective of Experiment OEA-5 is to determine the density distribution patterns of interstellar gas (Figure 6-32). An interferometer technique is used because it affords optimum performance over broad ranges of the IR spectrum. The primary sensor is an interferometer-telescope mounted on the forward end of the satellite so that it can pivot on the satellite longitudinal axes. S-band and UHF antennas extend from the satellite during operation. The following support systems are also included: communications, power, attitude control, and data automation.

## S E C T I O N 7

### R E L I A B I L I T Y, D E V E L O P M E N T S C H E D U L E, A N D C O S T A N A L Y S E S

#### 7.1 RELIABILITY ANALYSIS

##### 7.1.1 General

A reliability study was conducted as part of the Saturn In-Flight Experiment Payload Study. The main purpose of the reliability study was to determine the predicted reliability of the individual experiments. The major tasks of this study were (1) to determine the predicted reliability of the equipments, (2) to develop a reliability model for the experiments, and (3) to predict the reliability of the individual experiments.

##### 7.1.2 Equipment Reliability

The predicted reliability for each equipment was determined by the use of (1) space failure rates when available, (2) aircraft failure rates modified by an aircraft-to-space environmental factor when space failure rates were not available, and (3) similarity in equipment design and best engineering judgment, when the exact equipment design was not available.

The predicted reliabilities for the equipment of the individual experiments are presented in Table 7-1.

##### 7.1.3 Reliability Model

A set of model equations was formulated for predicting the individual experiment reliabilities. For this analysis, the individual experiment reliability was defined as the probability that a completely checked out experiment will be boosted into orbit, that all the required information will be obtained, and the obtained information relayed in the prescribed manner. Partial information recovery was not considered as a success; for example, if an experiment called for obtaining data with three sensors, all three sensors were assumed to be required for successful performance of the experiment. Information loss due to booster failure, weather, etc., was not included in this analysis. The duration of each experiment mission and the equipment operational phases of each experiment were assumed to be those proposed in each experiment write-up.

**TABLE 7-1  
PREDICTED MEAN-TIME-BETWEEN FAILURE OF EXPERIMENT EQUIPMENT**

EQUIPMENT	SDT					MS					MI					
	1	2	3	4	5	1	2	3	4	5	1	2	3	4	5	
EXPERIMENT	6700	12500	1100	9100	NO RELIABILITY CALCULATIONS WERE DONE ON THIS EXPERIMENT	4800	2500	11000	10000	11000	8000	850	500	750	3600	
DATA AUTOMATION	5000	-	5000	5000		5000	2700	2700	2700	2700	2700	2700	2700	1300	2700	5000
COMMUNICATIONS	3100	4400	3100	3100		3100	3100	3100	3100	3100	3100	3100	3100	3100	3100	6300
POWER SUPPLY	6600	6600	5900	6600		5900	6600	6600	6600	6600	6600	6600	6600	5900	6600	6600
ATTITUDE CONTROL	1700	-	1700	1700		1700	--	-	-	-	1700	1700	1700	1300	1700	
DATA RECOVERY CAPSULE	--	-	--	--		.9998	*	--	-	-	-	.9996	*	--	--	--

EQUIPMENT	SLG					M					OEA				
	1	2	3	4	5	1	2	3	4	5	1	2	3	4	5
EXPERIMENT	5900	4800	3700	4700	14300	6200	3700	8300	6700	5000	1100	2500	2000	10000	6700
DATA AUTOMATION	2700	2700	2700	5600	5000	4200	5000	2700	5000	2700	4000	5000	5000	6000	5000
COMMUNICATIONS	9500	3100	6300	--	3100	3100	3100	3100	3100	3100	6000	5100	3100	3100	3100
POWER SUPPLY	6600	6600	6600	6600	6600	6600	6600	6600	6600	6600	6600	6600	6600	6600	6600
ATTITUDE CONTROL	--	--	1700	--	-	--	--	--	--	--	--	1700	1450	1700	1700
DATA RECOVERY CAPSULE	* .9988	--	* .9998	* .9998	-	--	--	--	--	--	--	--	--	* .9998	--

\*PROBABILITY



Based on the above data, mathematical model equations were developed which express the experiment reliabilities in terms of equipment reliabilities. A model equation in general form is presented in Figure 7-1.

• ALL EQUIPMENTS IN AN EXPERIMENT OPERATE AS SERIES ELEMENTS (I.E. NO EQUIPMENT REDUNDANCY CONSIDERED)

$$R_E = \prod_{a=1}^n e^{-\frac{1}{\theta_a} [t_{1a} \beta_a + t_{2a} + t_{3a} \alpha_a]} \prod_{b=1}^m P_b$$

WHERE:  $R_E$  = EXPERIMENT RELIABILITY

$t_{1a}$  = BOOST PHASE TIME IN HOURS

$\beta_a$  = BOOST ENVIRONMENTAL FACTOR

$t_{2a}$  = EQUIPMENT "OPERATE" TIME IN HOURS

$t_{3a}$  = EQUIPMENT "OFF" TIME IN HOURS

$\alpha_a$  = EQUIPMENT ENVIRONMENTAL FACTOR FOR "OFF" CONDITION

$P_b$  = PROBABILITY OF TIME INDEPENDENT EQUIPMENT OPERATING

$\prod_{a=1}^n e^{-\frac{1}{\theta_a} [t_{1a} \beta_a + t_{2a} + t_{3a} \alpha_a]}$  = PRODUCT OF ALL EXPERIMENT EQUIPMENT RELIABILITIES FOR THE IN-FLIGHT DURATION

$\prod_{b=1}^m P_b$  = PRODUCT OF ALL TIME INDEPENDENT PROBABILITIES

Figure 7-1 GENERAL RELIABILITY MODEL EQUATION FOR SATURN IN-FLIGHT EXPERIMENTAL PAYLOAD STUDY

#### 7.1.4 Individual Experiment Reliability Predictions

Using the reliability model equation in Figure 7-1, the experiment duration, the equipment operational phases of the experiment, and the equipment reliabilities, the reliability of each individual experiment was predicted.

The individual experiment reliability predictions are contained in Table 7-2. The predicted reliability of the individual experiments range from 0.62 for experiment SDT-1 to 0.98 for experiments SLG-1, SLG-4, SLG-7, MS-2, MS-4 and MS-5.

**TABLE 7-2  
EXPERIMENT PREDICTED RELIABILITY**

EXPERIMENT	RELIABILITY	EXPERIMENT	RELIABILITY
SDT-1	.62	SLG-1	.98
SDT-2	.68	SLG-2	.97
SDT-3	.92	SLG-3	.95
SDT-4	.94	SLG-4	.98
SDT-5	---	SLG-5	.96
MS-1	.83	M-1	.92
MS-2	.98	M-2	.96
MS-3	.96	M-3	.90
MS-4	.98	M-4	.90
MS-5	.98	M-5	.85
MI-1	.86	OEA-1	.87
MI-2	.84	OEA-2	.93
MI-3	.75	OEA-3	.91
MI-4	.89	OEA-4	.94
MI-5	.81	OEA-5	.93

The probability of successfully completing an experiment for the total mission duration is low for certain experiments, e.g., 0.75 for the 14-day experiment MI-3. However, if partial information recovery can be classified as a limited success, then the predicted experiment reliability for MI-6 as a function of in-flight duration would be as presented in Figure 7-2.

## 7.2 DEVELOPMENT SCHEDULE ANALYSIS

It is expected that development time will have a decided influence on the final selection of the experiments that make up the Saturn IB/Apollo secondary payloads. Accordingly, a preliminary analysis of experiment development schedules was performed in this study. The resulting time-span estimates have been incorporated into the SEPTER model and are available as outputs that may be used in screening the experiments on the basis of timing compatibility.

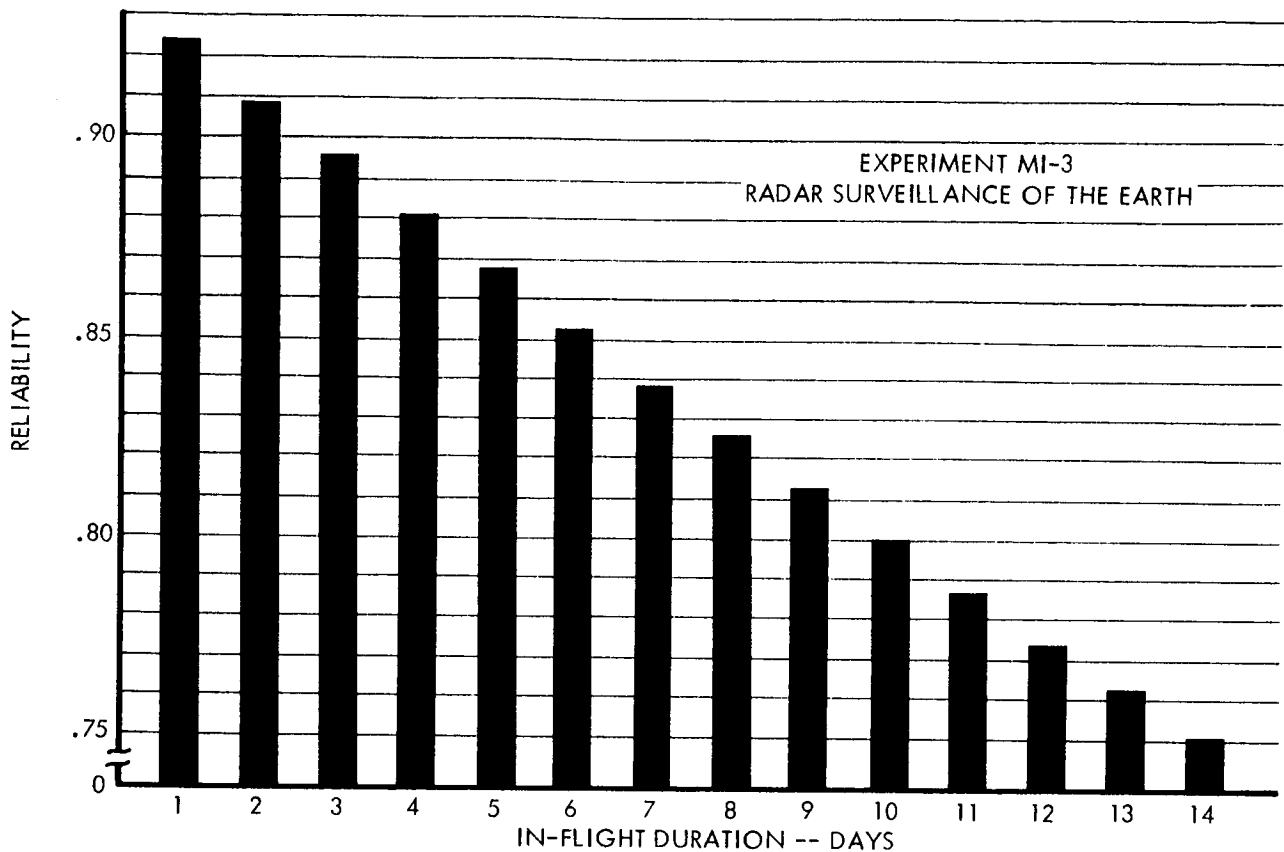

Figure 7-2 RELIABILITY FOR VARIOUS IN-FLIGHT DURATIONS

The technique employed in estimating the design/development spans may be summarized in two analytical steps. First, the experiments were ranked and categorized by considering for each experiment:

1. The expected difficulty in designing the individual pieces of equipment
2. The overall complexity of the integrated experimental and ancillary equipment
3. The extensiveness of the implied test programs.

Next, span times were estimated for each of the experiment categories by relating the experiment equipment to comparable equipment with known development spans. The results are tabulated in Table 7-3. The pacing features which are expected to significantly influence the development times for each experiment are noted in the table.

**TABLE 7-3  
DEVELOPMENT SCHEDULE ANALYSIS**

3/4 Year		
NO.	EXPERIMENT DESIGNATION	PACING FEATURE(S)
1.	MS-4	No problems - simple mechanism
2.	MS-2	No problems - simple technique
3.	SLG-2	Turntable apparatus, temperature control system
4.	MS-3	Power system for melting test specimens
5.	M-5	Culture cells, environmental control system
6.	M-2	T.V. system, environmental control system
7.	M-4	T.V. System, environmental control system (30 days)
8.	M-3	T.V. system, environmental control system (30 days)
9.	OEA-1	Sensors
10.	SDT-2	Propulsion system, data retrieval system (up to 1 year)

1 Year		
NO.	EXPERIMENT DESIGNATION	PACING FEATURE(S)
11.	MS-5	Sensors
12.	SLG-1	Environmental protection of film, recovery capsule
13.	SLG-4	Environmental protection of film, recovery capsule
14.	SLG-5	Test cell, relief chamber, specimen feed and ignition system
15.	M-1	Incubation chamber, exposure plates

1 1/2 Years		
NO.	EXPERIMENT DESIGNATION	PACING FEATURE(S)
16.	OEA-4	Attitude control system, dynamic tests, recovery capsule
17.	SLG-3	Attitude control system, temperature sensing servo, simulation tests
18.	SDT-4	Attitude control and Ullage orientation system, simulation tests
19.	OEA-5	Interferometer-telescope, attitude control & environmental control for long term mission
20.	MS-1	Fuel cell (at least 30 days), attitude control system, recovery capsule

2 1/4 Years		
NO.	EXPERIMENT DESIGNATION	PACING FEATURE(S)
21.	OEA-2	External observing optics, electron gun & gimbaling, complex test program
22.	MI-2	IR line scanner, attitude control (long term), integration tests
23.	OEA-3	Prototype star tracker, attitude control (accuracy), integration tests
24.	MI-5	Simulation/integration tests, attitude control (accuracy), cameras & gimbals
25.	MI-1	Sensors, complex integration tests
26.	MI-4	Telescope camera, welding mirror assembly, finder tracker, simulation/accuracy tests

3 Years		
NO.	EXPERIMENT DESIGNATION	PACING FEATURE(S)
27.	SDT-3	Navigation system, integrated systems design, complex test program
28.	MI-3	Side looking radar, test program
29.	SDT-1	Isotope power system, waste heat conversion components, proof of design tests

Notes: 1. Time span estimate are for "go-ahead" to first launch with Saturn IB/Apollo.  
2. Experiment SDT-5 (Launch of Unmanned Satellites and Probes) is not included because it involves the use of an existing satellite.

Since it is assumed that the experiments defined in this study are representative of those that finally may be considered, the magnitude and distribution of these estimated development spans may be used to indicate sensitivity and the importance of development time in the final selection process. The cumulative distribution of the experiment development times is plotted in Figure 7-3. Approximately one half of the experiments pose only a minor development problem; that is, their development spans are estimated to be one year or less. However, the development times associated with the remaining experiments are relatively long and are spread over a fairly wide range. Thus, the versatility of these latter experiments, in regard to secondary-payload grouping, is limited. This suggests the need for tradeoffs between (1) accelerated development and the attendant increase in costs and/or (2) shorter development spans, alternate experiment designs, and the possible increases in equipment weight and volume. While it was considered to be beyond the scope of this study, the addition of such tradeoffs as these to the experiment evaluation model would appear to be desirable.

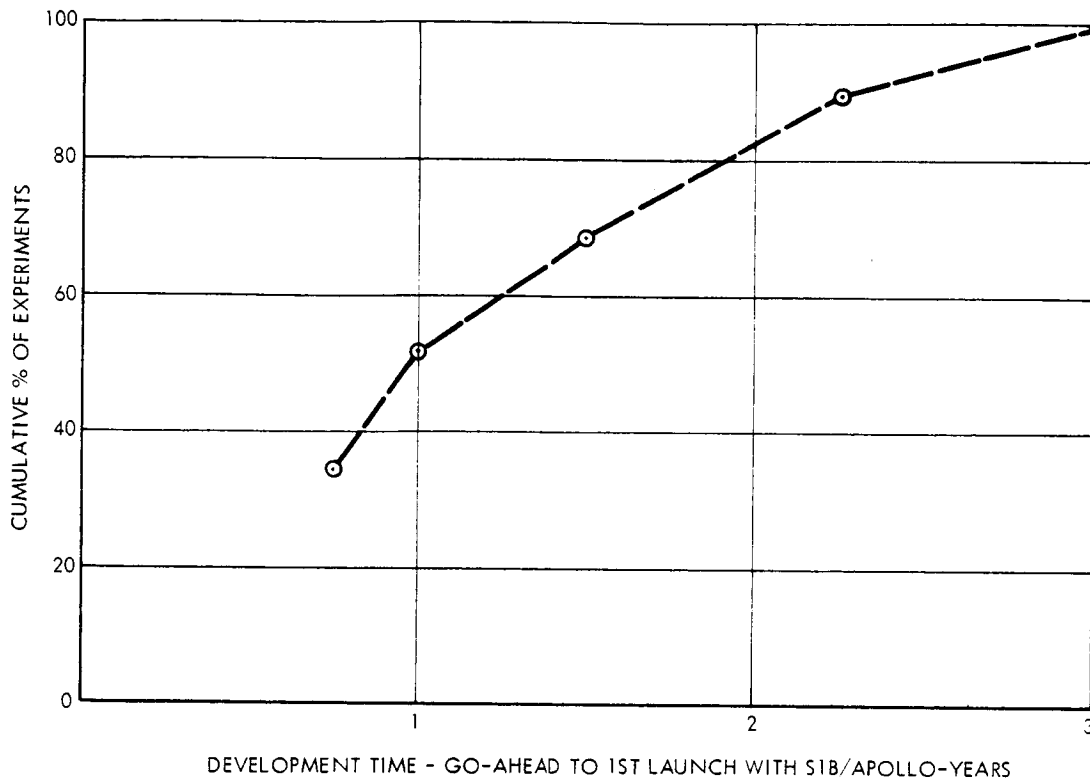

Figure 7-3 CUMULATIVE DISTRIBUTION OF DEVELOPMENT SPAN TIMES

### 7.3 COST ANALYSIS

Costs established for each experiment package are summarized in Table 7-4. These costs vary from \$288,000 for SDT-2 to \$3,343,000 for MI-3. The cost analysis was performed in the following steps:

1. Cost categories were established.
2. Estimating procedures were determined.
3. A historical data collection was made.
4. Costs were calculated and totaled.

Cost categories were determined largely from weight-statement breakdowns. Some simplifications were made for the sake of consistency and comparability of the various systems. In addition, development and system-integration costs were estimated. Ancillary subsystems were considered to be recurring cost categories, while the development and integration costs were considered to be non-recurring. The categories are summarized as follows:

TABLE 7-4  
COST ANALYSIS

Experiment Cost-\$1000

Subsystem/Experiment	SDT-1	SDT-2	SDT-3	SDT-4	MS-1	MS-2	MS-3	MS-4	MS-5
DATA HANDLING	41.3	2.0	18.0	19.0	23.0	23.0	28.0	28.0	28.0
POWER	168.0	5.2	54.0	105.5	89.4	20.5	41.0	30.0	25.0
STRUCTURE	23.8	.6	11.0	20.0	99.0	1.8	2.8	3.0	2.4
COMMUNICATIONS		7.0	11.1	12.0	8.6	12.3	11.3	10.5	10.5
ATTITUDE CONTROL	135.1	4.5	39.0	37.5	71.5				15.0
ENVIRONMENTAL CONTROL	8.7					15.0			
EXPERIMENT	100.0	10.0	180.0	70.0	20.0	10.0	10.0	50.0	50.0
TOTAL RECURRING	476.9	29.3	313.1	264.0	311.5	82.6	93.1	121.5	130.9
3 UNITS	1430.7	87.9	939.3	792.0	934.5	247.8	279.3	364.5	392.7
DEVELOP. & INTEGRATION	333.0	200.0	333.0	200.0	266.0	200.0	266.0	266.0	266.0
TOTAL EXPERIMENT	1763.7	287.9	1272.3	992.0	1200.5	447.8	545.3	630.5	658.7

	SLG-1	SLG-2	SLG-3	SLG-4	SLG-5	M-1	M-2	M-3	M-4	M-5
DATA HANDLING	30.0	30.0	30.0	20.0	19.0	.8	2.0		.8	29.0
POWER	13.5	48.5	37.0	17.0	36.0	13.5	14.5	43.7	21.0	56.0
STRUCTURE	19.2	3.3	6.2	19.0	2.6	7.2	3.0	10.0	6.0	11.8
COMMUNICATIONS	4.0	12.3	8.8		9.5	11.5	14.6	14.1	17.0	12.0
ATTITUDE CONTROL			31.5							
ENVIRONMENTAL CONTROL				6.6						
EXPERIMENT	11.0	53.0	34.0	18.0	11.0	52.0	75.0	22.0	42.0	52.0
TOTAL RECURRING	77.7	147.0	147.5	80.6	78.1	85.0	109.1	139.8	86.0	160.8
3 UNITS	233.1	441.3	442.5	241.8	234.3	255.0	327.3	419.4	258.0	482.4
DEVELOP. & INTEGRATION	200.0	200.0	200.0	200.0	200.0	266.0	266.0	266.0	200.0	200.0
TOTAL EXPERIMENT	433.1	641.3	642.5	441.8	434.3	521.0	593.3	685.4	458.0	682.4

	MI-1	MI-2	MI-3	MI-4	MI-5	OEA-1	OEA-2	OEA-3	OEA-4	OEA-5
DATA HANDLING	71.0	120.0	271.0	121.0	23.0	29.0	19.0	11.0	19.0	15.0
POWER	65.0	185.0	222.5	117.0	160.5	176.0	50.0	9.5	7.5	9.5
STRUCTURE	61.0	26.0	52.0	40.2	33.3	4.6	15.4	14.8	36.0	19.6
COMMUNICATIONS	12.1	17.1	42.1	16.0	8.6	4.0	7.0	7.0	9.0	12.3
ATTITUDE CONTROL	43.5	43.5	43.5	54.7	48.7		37.5	80.0	37.5	43.5
ENVIRONMENTAL CONTROL										
EXPERIMENT	100.0	100.0	350.0	70.0	173.0	186.0	150.0	100.0	100.0	100.0
TOTAL RECURRING	352.6	491.6	981.1	418.9	447.1	399.6	293.9	222.3	209.0	214.9
3 UNITS	1057.8	1474.8	2943.3	1256.7	1341.3	1198.8	881.7	666.9	627.0	644.7
DEVELOP. & INTEGRATION	465.0	333.0	400.0	266.0	465.0	333.0	266.0	400.0	266.0	333.0
TOTAL EXPERIMENT	1522.8	1807.8	3343.3	1522.7	1806.3	1531.8	1147.7	1066.9	993.0	977.7

1. Data Handling
2. Power
3. Structure
4. Communications
5. Attitude Control
6. Experiment
7. Development and Integration.

Estimating procedures were determined separately for recurring costs and nonrecurring costs. Recurring costs were estimated on a cost-per-pound basis for cost categories 1-5. A separate factor was determined for each category. Category 6, "Experiment," was estimated by use of weighting factors applied to a baseline estimate. The weighting factors were a combination of factors based on subjective analysis of the experiment description and the relative costs of various scientific instruments. Nonrecurring costs were estimated from a weighting factor applied to a subjective baseline. The weighting factor was a combination of three factors — complexity, data recovery, and state of the art — which were determined through an analysis of the experiment description.

There were not enough historical data available to form the basis for a pure statistical analysis. However, some information was available for establishing general guidelines. Most important was the IBM study on Extended Apollo Earth-Orbit Flights. Budgetary information was also available in gross form on Explorer XIV, OAO, OGO, Syncom, Relay and Nimbus.

Costs were calculated as explained in the estimating procedures. It was assumed that three payloads would be built in order to satisfy requirements of control experiments, system checkout, and the mission itself. No production learning was assumed.



## **PROGRAM DESIGN**



## S E C T I O N 8

### P R O G R A M D E S I G N M E T H O D O L O G Y

#### 8.1 GENERAL

A computer program (DESIGN) for determining the limited physical characteristics of arbitrary experiments was developed as a support program for computer Program SEPTER (Saturn Experimental Payload Technical Evaluation and Rating). This support program will provide gross inputs to SEPTER rather than detailed design data of experimental payloads. DESIGN replaces the manual system synthesis tasks involved in designing experimental payloads, and provides "first-pass" estimates of the mass and volume of the complete experimental payload. DESIGN does not provide geometric design data.

The methodology used in DESIGN was formulated on the basis of parametric data and design experience obtained during the initial phase of the study. The output characteristics of ancillary systems have been defined to satisfy given experiment input requirements. These characteristics are defined by means of analytical representations in the form of either curve fits (equations) or characteristics stipulated for required components.

#### 8.2 INPUT REQUIREMENTS

The input to the program includes: (1) the experiment sensor(s) requirements, (2) the experiment operational requirements, and (3) the systems functional requirements.

The experiment sensor(s) requirements are defined external to the program in terms of total mass, volume, peak power, and "on time" (time for each data acquisition cycle). Experiment operational requirements are defined by the mission duration and by specifying whether the experimental payload is deployed (ejected from the vehicle). The systems functional requirements are defined by numerical data and coded answers to a number of yes-or-no questions relative to each of the systems.

Additional inputs to the program include problem control data and options. Numerical constants used in the program are stored and provided to the program in the form of a library. This feature permits the user of the program to readily modify curve fits (equations) and component selection criteria as required by state-of-the-art changes.

### 8.3 CONSTRUCTION AND OPERATION

The overall construction and operation of program DESIGN is presented in Figure 8-1. The program utilizes the input data to select the systems and to define the characteristics of those systems that are required.

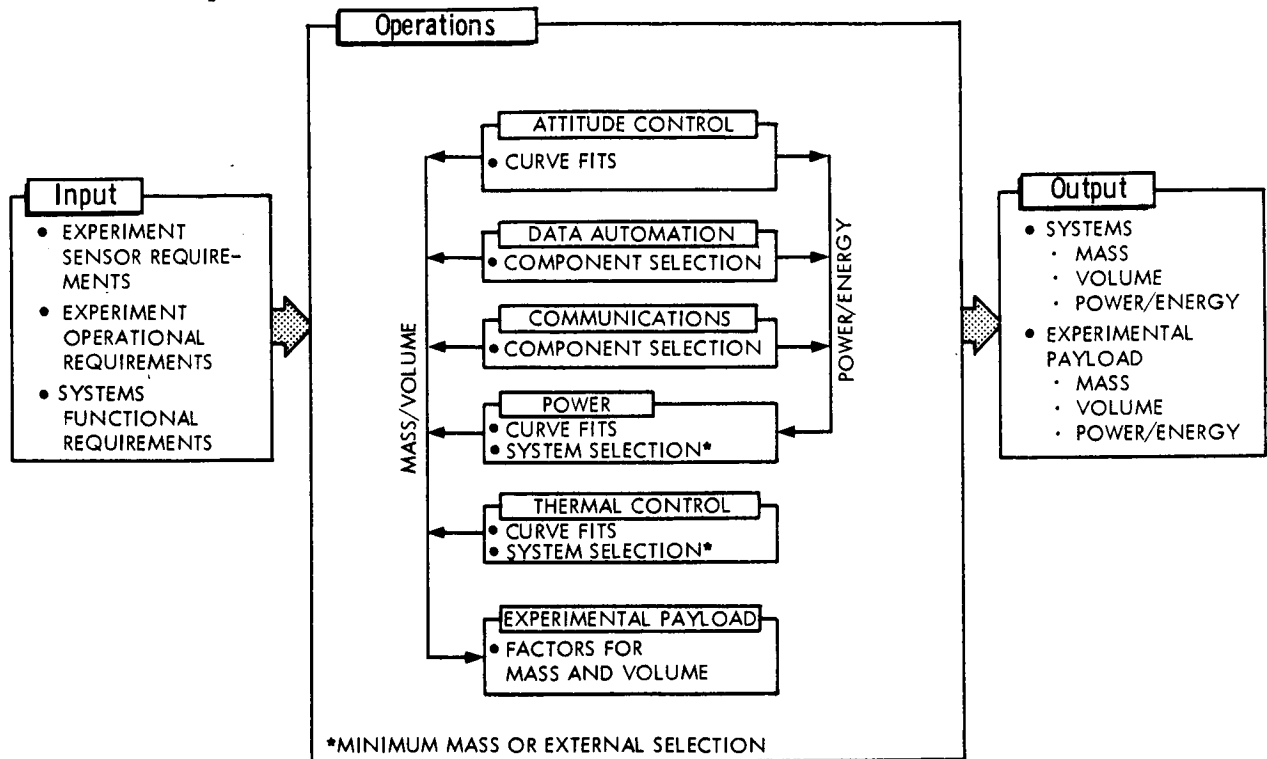

Figure 8-1 COMPUTER PROGRAM DESIGN CONSTRUCTION AND OPERATION

If stabilization of an experimental payload is required, an attitude control system is sized based on the mission duration and sensor pointing accuracy requirements. The program methodology used in the synthesis of attitude control systems is illustrated in Figures 8-2 and 8-3.

If the experimental payload requires a data automation system, component selection for this system is based on coded answers to yes-or-no questions in the input. The yes-or-no questions pertaining to data automation system requirements are shown in Figure 8-4, and a flow chart for component selection is given in Figure 8-5.

<b>Input Parameters</b> (MAXIMUM $L/\theta_E = 8$ WKS/DEG)	$L$ -- WEEKS $\theta_E$ -- DEGREES	MISSION DURATION* REQ'D POINTING ACCURACY
<b>Output Parameters</b> ( $50 \text{ LBS} \leq M_T \leq 124.28 \text{ LBS}$ ) ( $1112 \text{ IN.}^3 \leq V_T \leq 6089 \text{ IN.}^3$ )	$M_{TOTAL}$ -- LBS $V_{TOTAL}$ -- $\text{IN.}^3$	ATT CONT MASS ATT CONT VOLUME

Reference Case

**M1-1, Multispectral Surveillance of Earth**

- $L = 2$  WEEKS
- $\theta_E = \pm 1.5$  DEG.
- $M_{TOTAL} = 58$  LBS.
- $V_{TOTAL} = 1565$   $\text{IN.}^3$

Constants

•  $K_{REF} = \frac{1.5 \text{ DEG}}{2 \text{ WKS}} = 0.75 \text{ DEG/WK}$

- $K_{FIXED \text{ EQUIPMENT } -MASS} = 38.0 \text{ LBS}$
- $K_{PROPELLANT \text{ MASS-REF}} = 7.5 \text{ LBS}$
- $K_{TANK \text{ MASS-REF}} = 12.5 \text{ LBS}$

- $K_{FIXED \text{ EQUIPMENT } -VOL} = 660 \text{ IN.}^3$
- $K_{PROPELLANT \text{ TANK } -VOL-REF} = 288\pi \text{ IN.}^3$

\*POWER REQUIREMENTS - 50 WATTS CONTINUOUS

**Calculations**

- $M_{TOTAL} = K_{FIXED \text{ EQUIPMENT } -MASS} + \left(K_{REF} \frac{L}{\theta_E}\right) \cdot K_{PROPELLANT \text{ MASS-REF}} + \left(K_{REF} \frac{L}{\theta_E}\right)^{2/3} \cdot K_{TANK \text{ MASS-REF}}$
- $V_{TOTAL} = K_{FIXED \text{ EQUIPMENT } -VOL} + \left(K_{REF} \frac{L}{\theta_E}\right) \cdot K_{PROPELLANT \text{ VOL-REF}}$

$L/\theta_E \leq 0.67 \text{ WK/DEG}$

- $M_T = 50 \text{ LBS}$
- $V_T = 1112 \text{ IN.}^3$

Figure 8-2 ATTITUDE CONTROL SYNTHESIS

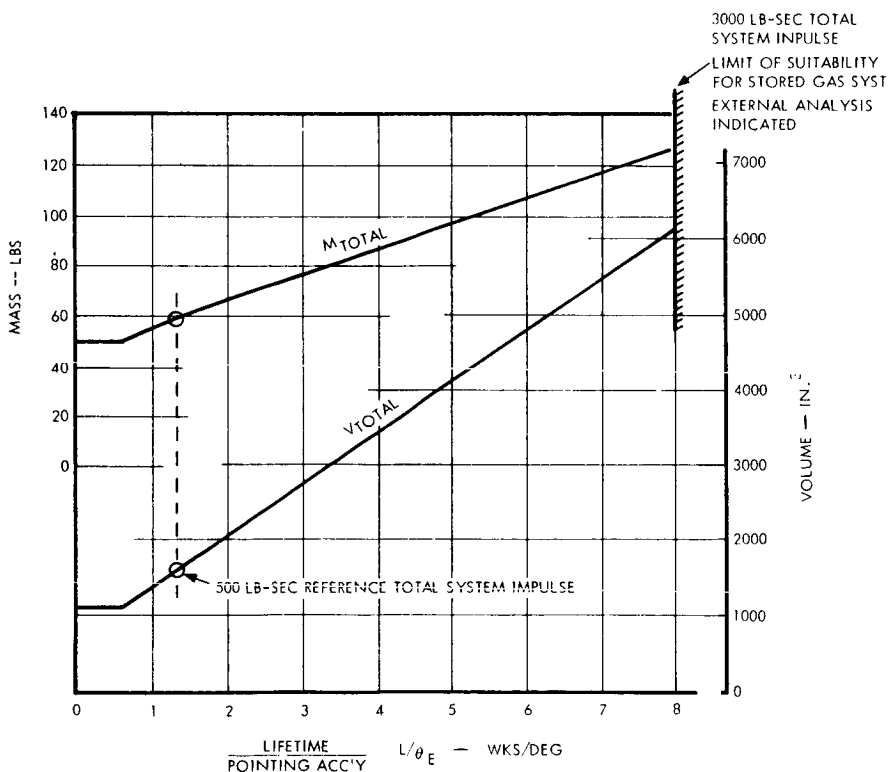

Figure 8-3 ATTITUDE CONTROL SYNTHESIS

Inputs		YES	NO
1.	Are there any data automation requirements?	_____	_____
2.	Are there events which occur in sequence at varying time intervals?	_____	_____
2.1	Can these times be determined before launch?	_____	_____
3.	Are there scientific or engineering data to be transmitted to Earth?	_____	_____
3.1	Is inflight processing of data required before recording?	_____	_____
3.2	Select size of tape recorder required:	_____	_____
3.2.1	Analog Tape Recorder 6 kHz bandwidth	_____	_____
3.2.2	Small Digital Tape Recorder 10 <sup>5</sup> bits	_____	_____
3.2.3	Large Digital Tape Recorder 10 <sup>8</sup> bits	_____	_____
4.	Select number of TV camers (800 line resolution) required: _____	_____	_____
4.1	Is storage of TV data for later playback required (3500' reel)?	_____	_____
5.	Are IR data to be recorded for later playback (3600' reel)?	_____	_____
6.	Are film camera data to be transmitted to Earth by telemetry?	_____	_____
7.	Should nuclear emulsion processing be initiated prior to recovery of nuclear emulsion package?	_____	_____
8.	Select number of data recovery capsules, (35 lbs. payload per capsule) _____ required for physical return to Earth of data or portions of experiment:	_____	_____

Outputs			
TOTAL DATA AUTOMATION SYSTEM	_____ LBS (MASS)	_____ IN. <sup>3</sup> (VOLUME)	_____ W (PEAK POWER)

Figure 8-4 DATA AUTOMATION SYNTHESIS - COMPONENT SELECTION

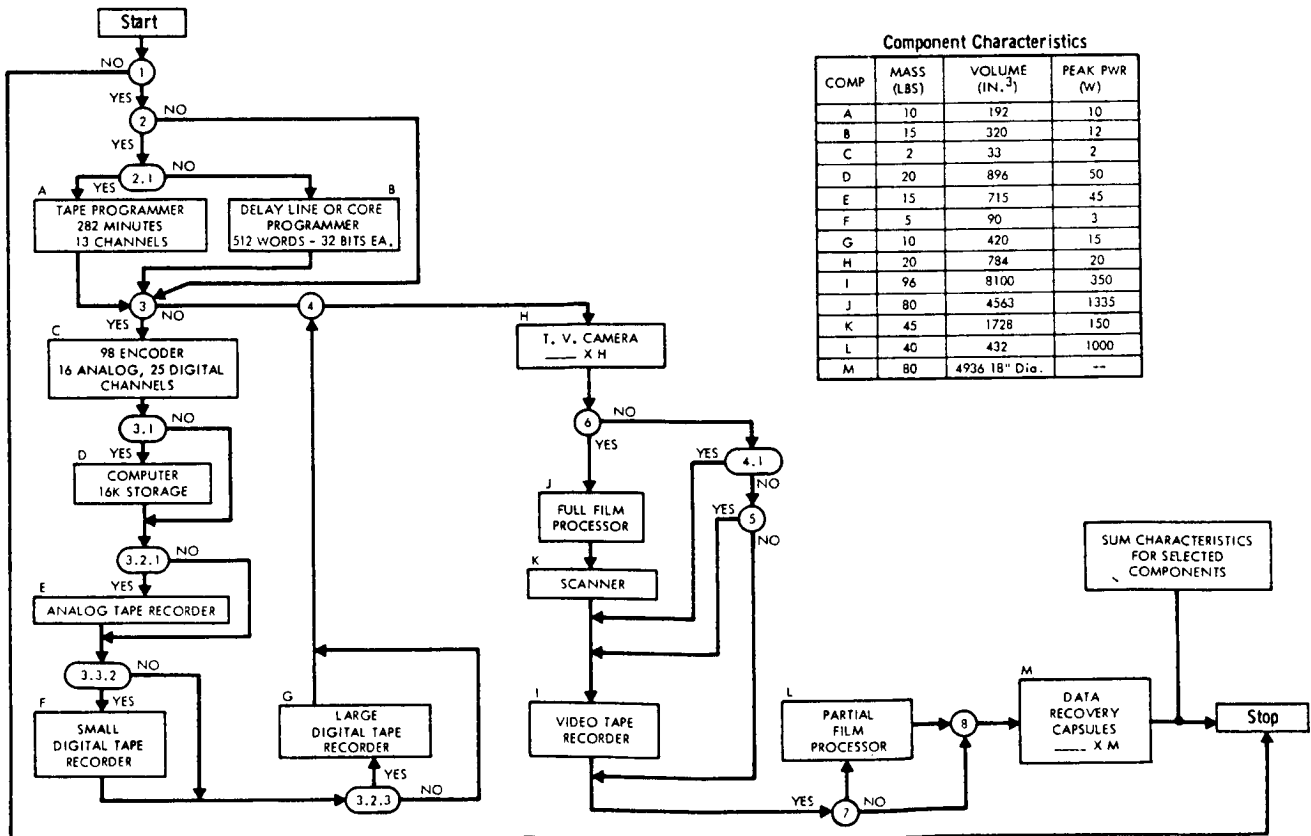

Figure 8-5 DATA AUTOMATION SYNTHESIS - FLOW CHART

The communications system synthesis is accomplished by the use of a method similar to that used for the data automation system. The questions pertaining to communications system requirements are given in Figure 8-6. A flow chart for component selection and component characteristics are given in Figure 8-7.

The electric power system synthesis utilizes the mission duration and the pertinent power/energy requirements of the various subsystems and sensors to determine the overall power/energy requirements of the experimental payload package. These overall power/energy requirements are computed by optionally specifying: (1) continuous operations for the mission duration, (2) duty cycles (hours of operation per day), or (3) average daily energy requirements. (However, the attitude control system, if required, is assumed to operate continuously at peak power). The type of power system can be specified as input or selected in the program on the basis of minimum mass.

Inputs		YES	NO
1	Are There Any Communication Requirements?	_____	_____
2	Is a Tracking Transponder Required for Locating Satellite?	_____	_____
3	Is Telemetry from Satellite to Earth Required?	_____	_____
4	Are Commands from Earth Otherwise Required?	_____	_____
5	Is either Analog or Digital (other than Video) Data Transmission Required?	_____	_____
5.1	Is Analog Data Transmission Required?	_____	_____
5.1.1	Are 30 Channels with Multiplex Capability Sufficient?	_____	_____
5.2	Is Digital Data Transmission Required?	_____	_____
5.2.1	Are 60 signals at 160 Samples/Second Sufficient?	_____	_____
6	Is Video Data Transmission Required?	_____	_____
6.1	Is a Capability from 0 to 5 MHz Bandwidth Sufficient.	_____	_____
7	Is Satellite to be Stabilized with Respect to Earth?	_____	_____

Component Characteristics			
	MASS (LBS)	VOLUME (IN. <sup>3</sup> )	PEAK PWR (W)
A S-BAND TRANSPONDER _____	0 or 4.5	0 or 60	0 or 35
B COMMAND RECEIVER _____	0 or 2.5	0 or 40	0 or 6
C UHF CIRCULATOR _____	0 or 1.0	0 or 50	_____
D UHF ANALOG TRANSMITTER (PAM/FM/FM) _____	0 or 2.5	0 or 40	0 or 10
E UHF DIGITAL TRANSMITTER (PCM/FM) _____	0 or 2.5	0 or 40	0 or 10
F S-BAND TV TRANSMITTER _____	0 or 7.0	0 or 93	0 or 50
G S-BAND ANTENNA SWITCH _____	0 or 0.8	0 or 17	_____
H <sub>s</sub> S-BAND ANTENNAS (STABILIZED W.R.T. EARTH) _____	0 or 1.5	0 or 62	_____
H <sub>u</sub> (UNSTABILIZED W.R.T. EARTH) _____	0 or 2.0	0 or 74	_____
I <sub>s</sub> UHF ANTENNAS (STABILIZED W.R.T. EARTH) _____	0 or 1.0	0 or 62	_____
I <sub>u</sub> (UNSTABILIZED W.R.T. EARTH) _____	0 or 1.5	0 or 74	_____

Outputs	
TOTAL COMMUNICATIONS SYSTEM _____	_____ LBS _____ IN. <sup>3</sup> _____ W

Figure 8-6 COMMUNICATIONS SYSTEM SYNTHESIS - COMPONENT SELECTION

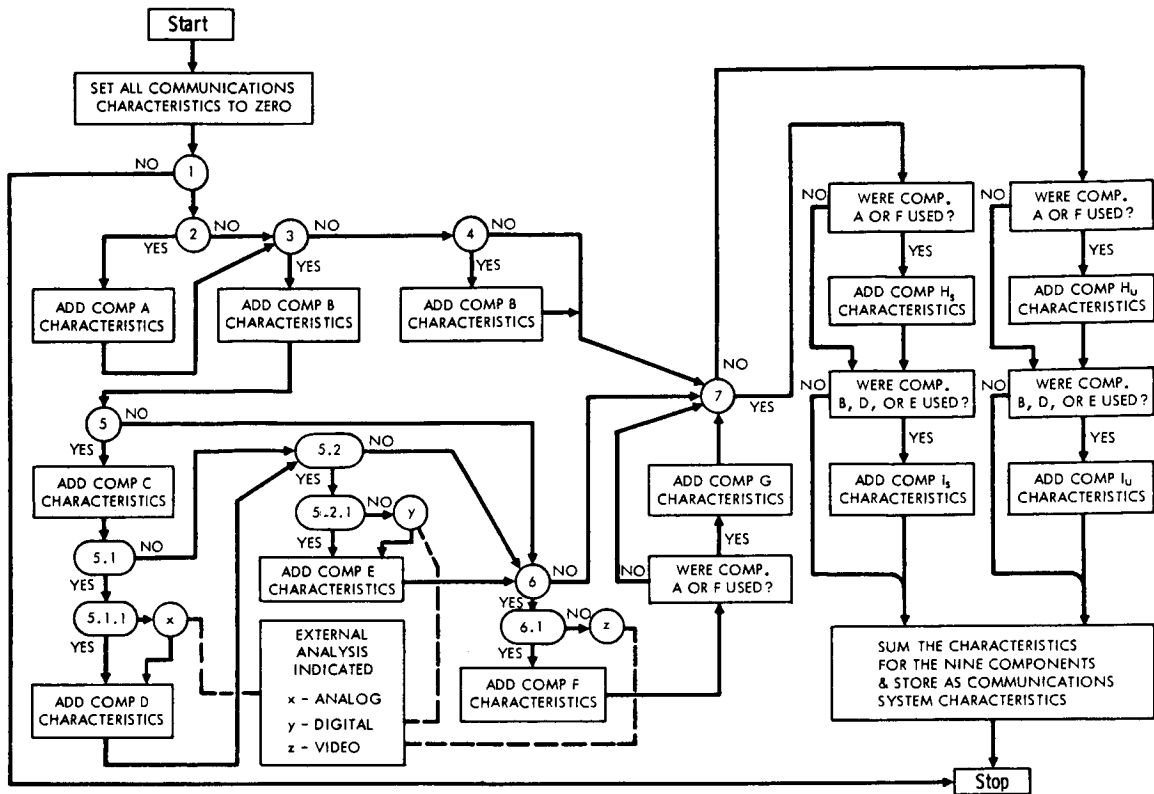

Figure 8-7 COMMUNICATIONS SYSTEM SYNTHESIS - FLOW CHART

Figure 8-8 contains the equations for the mass, volume, and deployed area applicable to various electric power systems which might be considered for use in experiments of the size and complexity similar to those synthesized in the study. These equations represent approximations to curves resulting from interpolations and/or extrapolations based on typical state-of-the-art systems.

A means for automatic selection of a power system has been provided as indicated in Figure 8-9. This method of selection is based on a minimum mass concept. Discriminants were derived as the result of comparisons between several equations for the system mass. Such a procedure cannot fully supplant the human judgment normally exercised in selecting a system. Hence, an option has been provided to allow external selection of the electric power system to be utilized in a given experiment package.

<b>Input Parameters</b>	$W_{PEAK}$ - WATTS _____ PEAK POWER REQUIRED
	$W_{H/D}$ - WATT-HOURS/DAY _____ DAILY ENERGY REQUIRED
	$D$ - DAYS _____ DURATION OF REQUIREMENT
<b>Output Parameters</b>	$M_{TOTAL}$ - LBS _____ POWER SYSTEM MASS
	$V_{TOTAL}$ - IN <sup>3</sup> _____ POWER SYSTEM VOLUME
	$A_{TOTAL}$ - IN <sup>2</sup> _____ EXPOSED AREA

**Limitation**

Approximation formulas below yield rough estimates of masses, volumes, and areas for power systems as function of peak watts, watt-hours/day, and days. Comparative conclusions based on these data must be used with care. (An external backup provision is available for system selection)

Calculations	MASS (LBS) VOLUME (IN. <sup>3</sup> )	AREA (IN. <sup>2</sup> )
	● SLIVER ZINC PRIMARY BATTERY	$W_{TOTAL} = 10. + 0.02 \cdot W_{PEAK} + 0.0167 \cdot W_{H/D} \cdot D$ $V_{TOTAL} = 100.2 + .2004 \cdot W_{PEAK} + .2886 \cdot W_{H/D} \cdot D$
● FUEL CELL DIRECT	$W_{TOTAL} = 10. + 0.17 \cdot W_{PEAK} + 0.0025 \cdot W_{H/D} \cdot D$ $V_{TOTAL} = 100.2 + 4.32 \cdot W_{PEAK} + 0.432 \cdot W_{H/D} \cdot D$	$A_{TOTAL} = 51.84 \cdot W_{PEAK}$
● SOLAR ARRAY & BATTERY	$W_{TOTAL} = 10. + 0.02 \cdot W_{PEAK} + 0.122 \cdot W_{H/D}$ $V_{TOTAL} = 100.2 + .2004 \cdot W_{PEAK} + 1.503 \cdot W_{H/D}$	$A_{TOTAL} = 14.170 \cdot W_{H/D}$
● RTG DIRECT	$W_{TOTAL} = 10. + 0.5 \cdot W_{PEAK}$ $V_{TOTAL} = 172.8 + 8.64 \cdot W_{PEAK}$	$A_{TOTAL} = 1382.4 + 69.12 \cdot W_{PEAK}$
● RTG & BATTERY	$W_{TOTAL} = 10. + 0.02 \cdot W_{PEAK} + 0.144 \cdot W_{H/D}$ $V_{TOTAL} = 100.2 + .2004 \cdot W_{PEAK} + 2.195 \cdot W_{H/D}$	$A_{TOTAL} = 5.53 \cdot W_{H/D}$

**Figure 8-8 POWER SYSTEM SYNTHESIS**

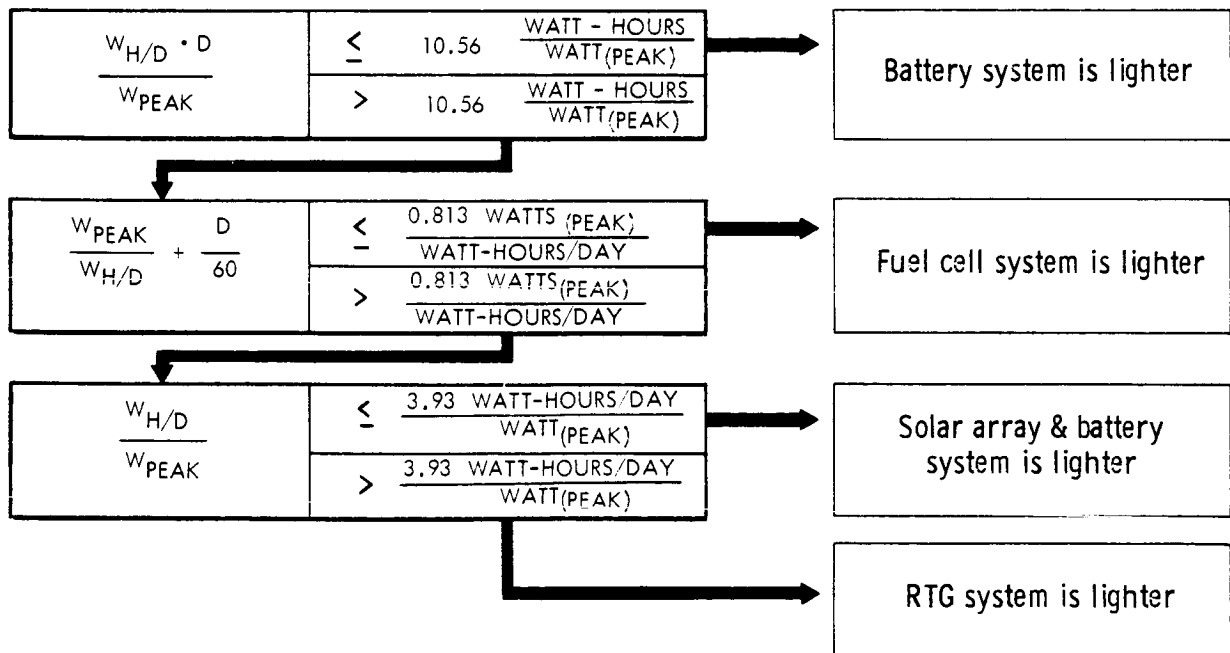

**Figure 8-9 POWER SYSTEM SYNTHESIS - AUTOMATIC SYSTEM SELECTION**

The relationships of the various parameters involved in electric power systems are illustrated in Figure 8-10. It can be seen that the mass of battery and fuel cell direct systems depend upon the requirements for peak watts and total watt-hours. The mass of a solar array and battery system is a function of peak power and daily energy requirements. Parametric data for four electric power systems are plotted separately in Figures 8-11 through 8-14.

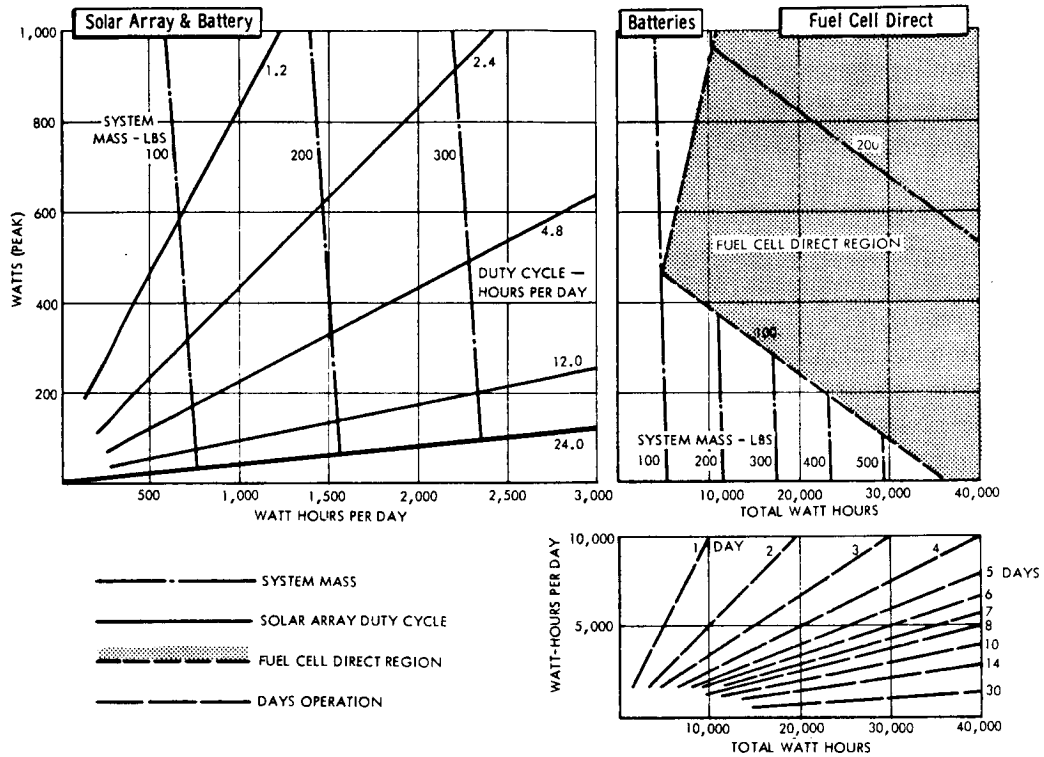

Figure 8-10 ELECTRIC POWER SYSTEM RELATIONSHIPS



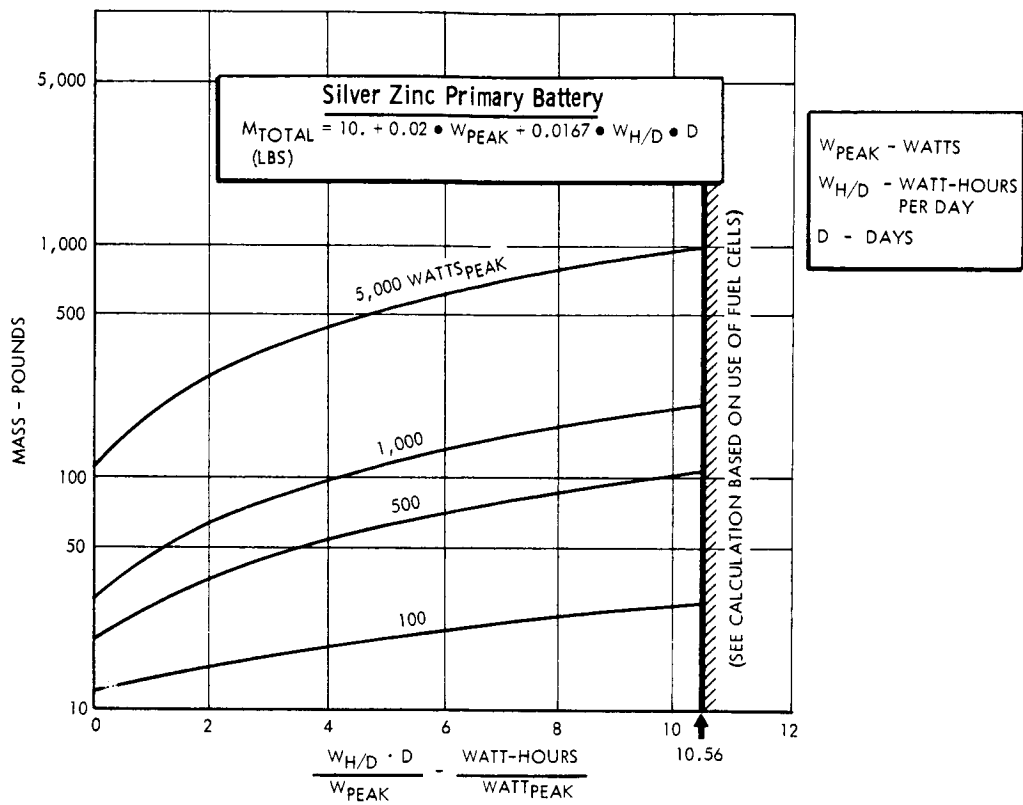

Figure 8-11 ELECTRIC POWER SYSTEM RELATIONSHIPS

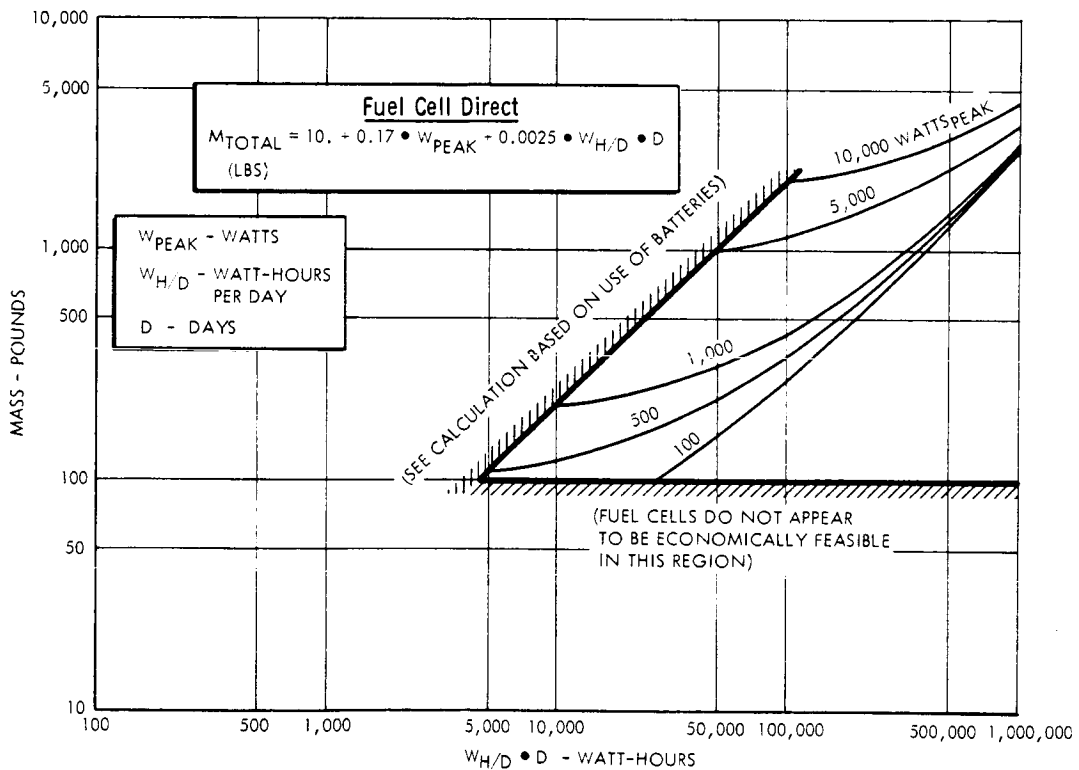

Figure 8-12 ELECTRIC POWER SYSTEM RELATIONSHIPS

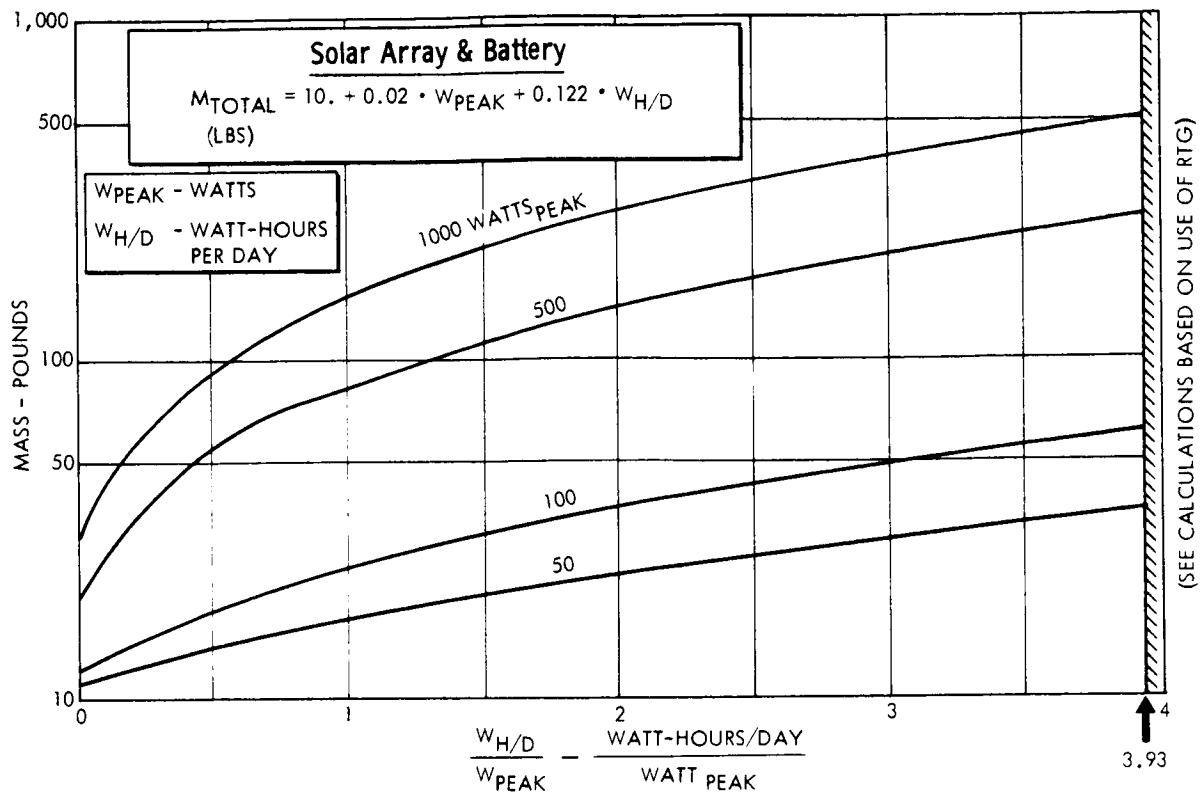

Figure 8-13 ELECTRIC POWER SYSTEM RELATIONSHIPS

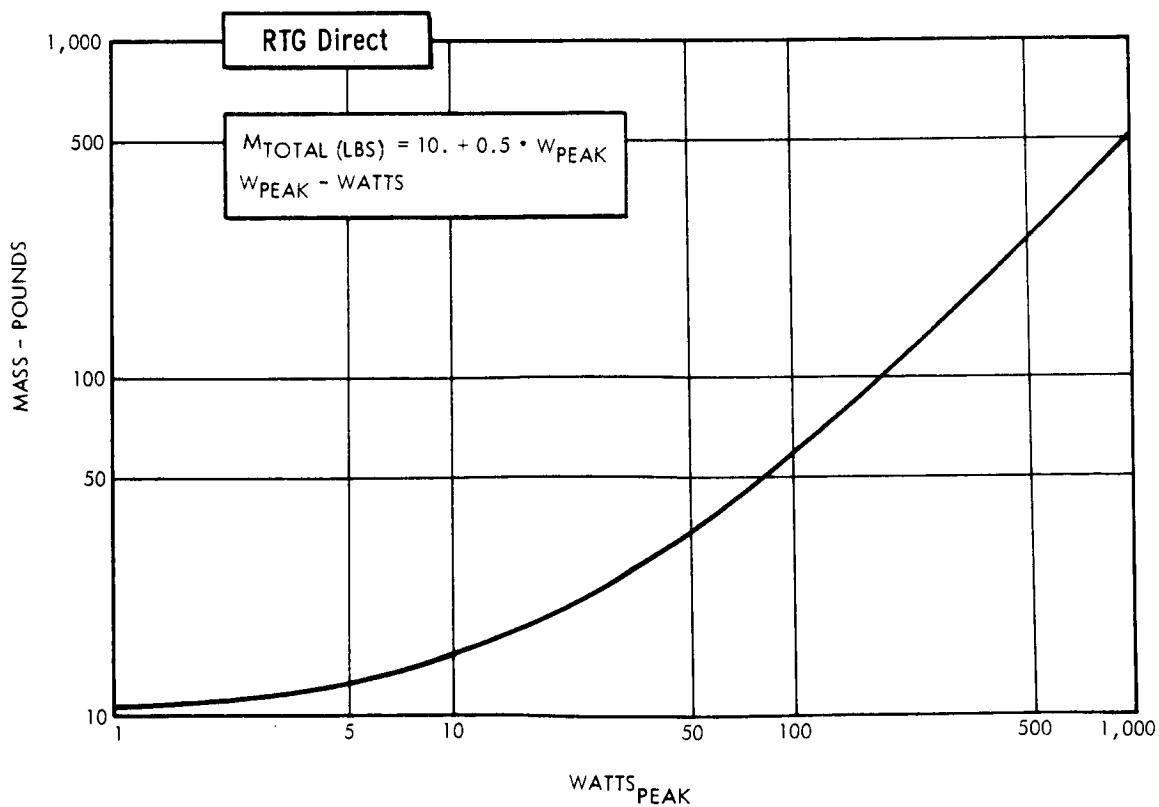

Figure 8-14 ELECTRIC POWER SYSTEM RELATIONSHIPS

It is assumed that the basic requirement of a thermal control system for an experimental payload is to remove excess heat, i.e., a cooling system. Two passive heat dissipation criteria are considered first: (1) total thermal inertia of the experimental payload mass, and (2) the radiative heat rejection capability of the experimental payload envelope area.

The total thermal inertia of the system is evaluated in terms of a thermal inertia parameter which relates equipment "on time," peak power, and overall mass, as expressed in the following equation:

$$E_t = \frac{(\Delta t) (\dot{Q}_p)}{M}$$

where:  $E_t$  = thermal inertia parameter  $\sim$  min.-watts/lb<sub>m</sub>

$\Delta t$  = equipment "on time"  $\sim$  min.

$\dot{Q}_p$  = total peak power  $\sim$  watts

$M$  = payload mass  $\sim$  lb<sub>m</sub>

If the calculated result is less than 140 min.-watts/lb<sub>m</sub> (which corresponds to a temperature rise of 40°F for a specific heat of 0.2), it is assumed that transient heat loads are absorbed by the equipment, and no external cooling is required.

If the above evaluation indicates that transient heat loads are not absorbed, the overall passive heat dissipation of the system is evaluated in terms of a passive heat dissipation parameter as expressed by the following equation:

$$H_p = \frac{\dot{Q}_{avg}}{A}$$

where:  $H_p$  = passive heat dissipation parameter  $\sim$  watts/in.<sup>2</sup>

$\dot{Q}_{avg}$  = total average power  $\sim$  watts

$A$  = experimental payload envelope area  $\sim$  in.<sup>2</sup>

If the calculated result is less than 1/16 watt/in.<sup>2</sup>, it is assumed that the heat is dissipated by radiation to an effective environment temperature of 0°F.

If a passive system is indicated by the above evaluations, the mass and volume requirements are assumed to be negligible (within the overall accuracy of the program).

In the event that the passive cooling modes are not effective, (as defined by the above evaluation) an active cooling system is calculated using the criteria given in Figures 8-15 and 8-16. The mass and volume equations for the water boiler system are given in terms of the average heat dissipation rate ( $\dot{Q}_{avg}$ ) in watts and the duration of the heat dissipation (t) in hours. In program DESIGN it is assumed that all input electric power for each component is dissipated in the form of heat. It can be seen that the mass and volume of the radiator system depends only on the dissipation rate and not on the duration of the dissipation.

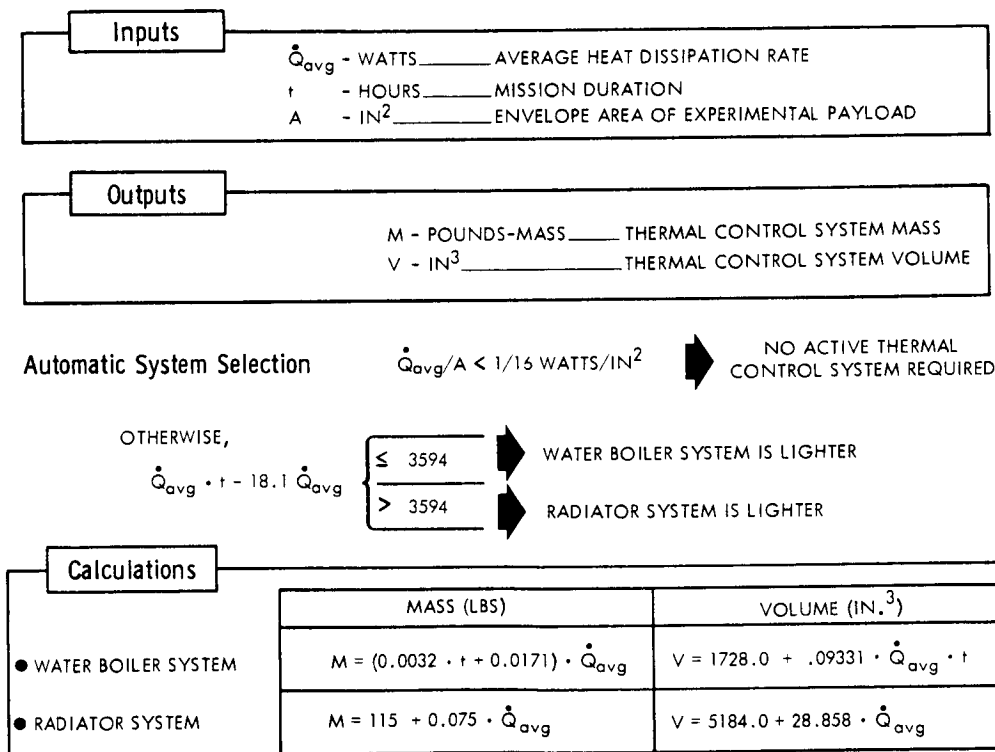

Figure 8-15 THERMAL CONTROL SYSTEM - ACTIVE SYSTEMS

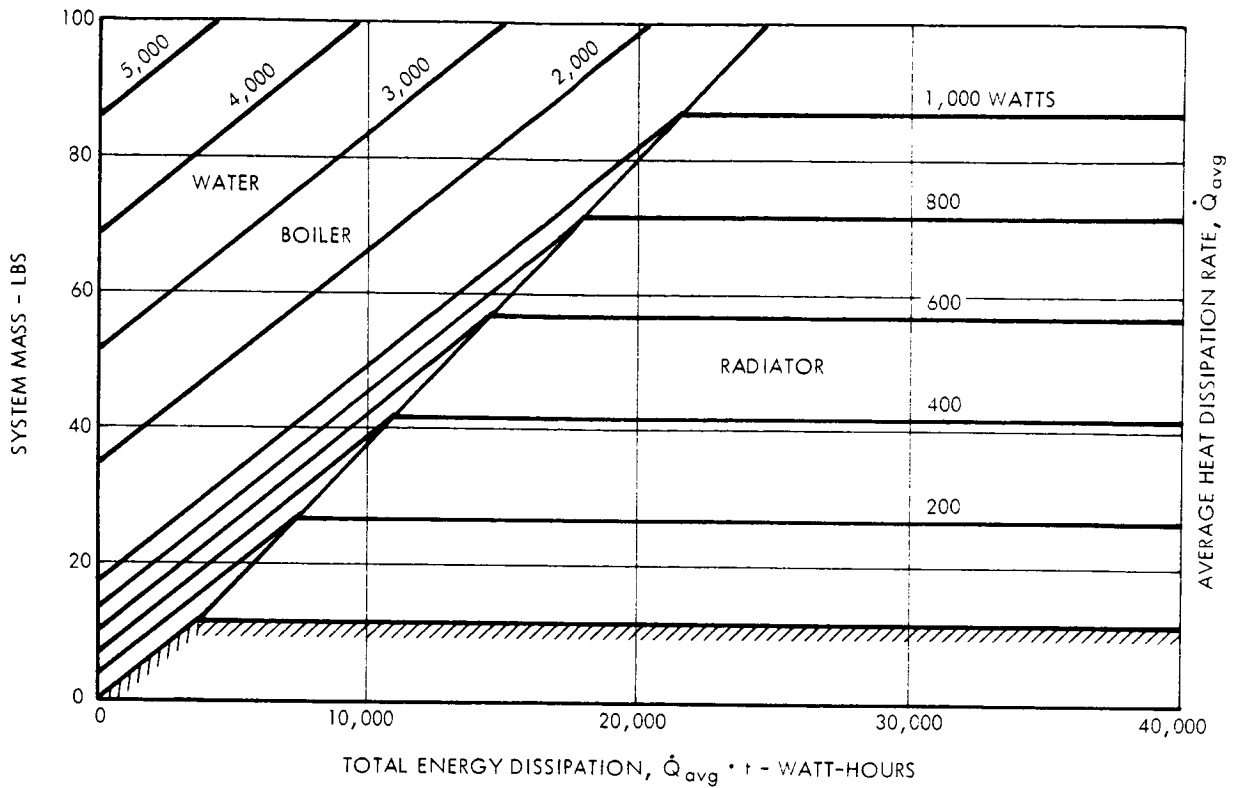

Figure 8-16 THERMAL CONTROL SYSTEM

The approximate total mass and volume of the experimental payload is determined by summing the masses and volumes of the systems and sensors and applying factors (based on manual design techniques and experience) to the sums. The experimental payload mass, including structure, is determined by multiplying the sum of the masses of the systems and sensors by a factor of 1.15. If, in addition, ejection equipment is required for deployment, the sum of the masses of the systems, sensors, and structure (as obtained by using the factor, 1.15) is multiplied by a factor of 1.10. The approximate total volume of the experimental payload is obtained by summing the volumes of the systems and sensors and multiplying this volume by a factor of 1.7 (if the experimental payload is not deployed). If deployment is required, a factor of 2.5 is used.

## 8.4 PROGRAM OUTPUT

The output of Program DESIGN consists of printed results containing the following types of data:

1. Input data (an optional print-out of the program). An example print-out of the input data is given in Figure 8-17.
2. Major heading listings of the systems which have been selected for the experimental payload.
3. Subheading listings of the components of each system. The mass, volume, and power requirements are given for each component, and the totals are given for each system. In the case of the power system synthesis, the peak power, daily energy, and total energy requirements of each system are listed, as well as the total requirements of the power system. The thermal control system synthesis output gives the type of system utilized and the values of the controlling criteria for the selection of either a passive or active system. If an active system is required, the type (water boiler or radiator) is specified.
4. An experimental payload summary in which the masses and volumes of all systems and sensors and the total mass and volume of the experimental payload package (including allowances for structure and ejection equipment, if required) are listed.

An example of the computer program output is given in Figure 8-18.

DESIGN-INPUT DATA

EXPERIMENT SDT- 4

EXPERIMENT SENSORS REQUIREMENTS

MASS (LB)	84.0
VOLUME (CU.IN.)	5147.0
PEAK POWER (WATTS)	6.0
ON TIME (MIN)	1440.0

EXPERIMENT OPERATION REQUIREMENTS

MISSION DURATION (DAYS)	4.0
DEPLOYMENT IS REQUIRED	YES

SYSTEMS FUNCTIONAL REQUIREMENTS

ATTITUDE CONTROL REQUIREMENTS

ATTITUDE CONTROL IS REQUIRED	YES
SENSOR POINTING ACCURACY (DEG)	3.0

DATA AUTOMATION REQUIREMENTS

JDA- 1 DATA AUTOMATION IS REQUIRED	YES
JDA- 2 EVENTS OCCUR IN SEQUENCE AT VARYING TIME INTERVALS	NO
JDA- 3 EVENTS TIMES CAN BE DETERMINED BEFORE LAUNCH	NO
JDA- 4 DATA IS TRANSMITTED TO EARTH	YES
JDA- 5 DATA PROCESSING IS REQUIRED BEFORE RECORDING	NO
JDA- 6 ANALOG TAPE RECORDER IS REQUIRED	YES
JDA- 7 SMALL DIGITAL TAPE RECORDER IS REQUIRED	NO
JDA- 8 LARGE DIGITAL TAPE RECORDER IS REQUIRED	NO
NUMBER OF TV CAMERAS	-0.
JDA- 9 STORAGE OF TV DATA FOR LATER PLAYBACK IS REQUIRED	NO
JDA-10 IR DATA IS RECORDED FOR LATER PLAYBACK	NO
JDA-11 FILM CAMERA DATA IS TRANSMITTED BY TELEMETRY	NO
JDA-12 NUCLEAR EMULSION PROCESSING IS REQUIRED	NO
NUMBER OF DATA CAPSULES(35 LB/CAPSULE)	-0.

COMMUNICATIONS SYSTEM REQUIREMENTS

JCS- 1 COMMUNICATIONS ARE REQUIRED	YES
JCS- 2 A TRACKING TRANSPONDER IS REQUIRED	YES
JCS- 3 TELEMETRY FROM SATELLITE TO EARTH IS REQUIRED	YES
JCS- 4 COMMANDS FROM EARTH ARE REQUIRED	NO
JCS- 5 ANALOG OR DIGITAL DATA TRANSMISSION IS REQUIRED	YES
JCS- 6 ANALOG DATA TRANSMISSION IS REQUIRED	NO
JCS- 7 30 ANALOG CHANNELS (MULTIPLEX) ARE SUFFICIENT	NO
JCS- 8 DIGITAL DATA TRANSMISSION IS REQUIRED	YES
JCS- 9 60 DIG. SIGNALS(160 SAMPLES/SEC) ARE SUFFICIENT	YES
JCS-10 VIDEO DATA TRANSMISSION IS REQUIRED	NO
JCS-11 VIDEO CAPABILITY FROM 0 TO 5 MHZ BANDWIDTH IS SUFFICIENT	NO
JCS-12 STABILIZATION IS REQUIRED	YES

POWER SYSTEM REQUIREMENTS

POWER SYSTEM SELECTION OPTION--  
BATTERY

DAILY ENERGY REQUIREMENT OPTION--  
1-DUTY CYCLE SPECIFIED

DUTY CYCLE(HR/DAY)--EXPERIMENT SENSORS	24.00
DUTY CYCLE(HR/DAY)--DATA AUTOMATIONS	24.00
DUTY CYCLE(HR/DAY)--COMMUNICATIONS	16.00
DUTY CYCLE(HR/DAY)--THERMAL CONTROL	24.00

Figure 8-17 DESIGN - PROBLEM INPUT DATA PRINTOUT

EXPERIMENT SDT- 4

ATTITUDE CONTROL SYSTEM SYNTHESIS

COMPONENTS	MASS (LB)	VOL (CU.IN.)
FIXED EQUIPMENT	38.0	660.0
PROPELLANT	3.8	
PROPELLANT TANKS	7.9	454.7
TOTALS	49.7	1114.7

DATA AUTOMATION SYSTEM SYNTHESIS

COMPONENTS	MASS (LB)	VOL (CU.IN.)	POWER (WATTS)
ENCODER	2.0	33.0	2.0
ANALOG TAPE RECORDER	15.0	715.0	45.0
TOTALS	17.0	748.0	47.0

COMMUNICATIONS SYSTEM SYNTHESIS

COMPONENTS	MASS (LB)	VOL (CU.IN.)	POWER (WATTS)
S-BAND TRANSPONDER	4.5	60.0	35.0
COMMAND RECEIVER	2.5	40.0	6.0
UHF CIRCULATOR	1.0	50.0	0.
UHF DIGITAL TRANSMITTER	2.5	40.0	10.0
S-BAND ANTENNAS- STABILIZED	1.5	62.0	0.
UHF ANTENNAS- STABILIZED	1.0	62.0	0.
TOTALS	13.0	314.0	51.0

POWER SYSTEM SYNTHESIS

MISSION DURATION(DAYS)= 4.0

SYSTEMS	PEAK POWER (WATTS)	DAILY ENERGY (WATT-HR/DAY)	TOTAL ENERGY (WATT-HR)
EXPERIMENT SENSORS	6.0	144.0	576.0
ATTITUDE CONTROL	50.0	1200.0	4800.0
DATA AUTOMATION	47.0	1124.0	4512.0
COMMUNICATIONS	51.0	816.0	3264.0
THERMAL CONTROL	0.	0.	0.
TOTAL POWER SYSTEM REQMT.	154.0	3284.0	13152.0

TYPE OF POWER SYSTEM-BATTERY

MASS OF POWER SYSTEM (LB) 232.7

VOLUME OF POWER SYSTEM (CU.IN.) 3926.4

EXPOSED AREA OF POWER SYSTEM (SQ.IN.) N/A

THERMAL CONTROL SYSTEM SYNTHESIS

TYPE OF SYSTEM-PASSIVE

HEAT DISSIPATION PARAMETER (0.014 WATTS/SQ.IN.) IS LESS THAN CRITICAL VALUE (0.062 WATTS/SQ.IN.)

MASS AND VOLUME ASSUMED TO BE NEGLIGIBLE

EXPERIMENTAL PAYLOAD SUMMARY

MASS SUMMARY

SENSORS (LB)	84.0
SYSTEMS (LB)	312.4
STRUCTURES (LB)	59.5
EJECTION EQUIPMENT (LB)	45.6
TOTAL MASS OF EXPERIMENT (LB)	501.4

VOLUME SUMMARY

SENSORS (CU.IN.)	15147.0
SYSTEMS (CU.IN.)	6103.1
TOTAL-BASIC COMPONENTS (CU.IN.)	21250.1
TOTAL VOLUME OF EXPERIMENT (CU.IN.)	63750.3

Figure 8-18 DESIGN - OUTPUT DATA PRINTOUT



part III

# APPENDICES

## A P P E N D I X A

### E X P E R I M E N T D E S C R I P T I O N S

The descriptions of each of the 30 representative experiments that were defined in the Saturn In-Flight Experimental Payload Study are presented in Sections A.1 through A.6 of this appendix. They are arranged in accordance with the categories established by the Fort Worth Division.

- A.1 Category I - Systems Development and Test (SDT)
- A.2 Category II - Materials and Structures (MS)
- A.3 Category III - Multispectral Imagery of the Earth and Orbiting Objects (MI)
- A.4 Category IV - Solid/Liquid/Gas Behavior (SLG)
- A.5 Category V - Microorganisms (M)
- A.6 Category VI - Observations of the Earth's Atmosphere, the Space Environment, and Astronomical Phenomena (OEA).

The experiment descriptions, which constitute the first step in the experiment design effort, were prepared by the individual experimenters working in the above-described disciplines. The objectives, sensors, and general scope of the experiments are defined therein. The data obtained from the descriptions served as a basis for the definition of the ancillary systems and the conceptual design drawings of each of the 30 experiments. The drawings are presented as the final page of each experiment description.

## A.1

### CATEGORY I - SYSTEMS DEVELOPMENT AND TEST (SDT)

The experiments in Category I provide for the development and test of advanced space systems in an environment very nearly identical to the one that would be experienced beyond the vicinity of the Earth. The five experiments in this category are designated as follows:

- SDT-1: Radioisotope-Thermoelectric Power System Integration
- SDT-2: Performance Assessment of Thin-Film Solar Cell Arrays
- SDT-3: Performance Assessment of Spacecraft Navigation, Guidance and Control Hardware, and Techniques
- SDT-4: Cryogenic Propellant Storage System Performance
- SDT-5: Launch of Unmanned Satellites and Probes.

A conceptual design drawing for each of the 5 experiments is presented on the last page of each experiment description. In many cases, illustrations and tabular data relating to the experiment are included in the final pages of the description.

1. EXPERIMENT SDT-1: Radioisotope-Thermoelectric Power System Performance
2. TECHNICAL AREA/APPLICATIONS:
  - 2.1 GENERAL AREA: Subsystems Development and Test
  - 2.2 EXPERIMENT APPLICATIONS: To space-qualify new subsystems and processes for Extended Mission Apollo.
3. EXPERIMENT OBJECTIVES AND SCOPE:
  - 3.1 OBJECTIVES
    - a. Specific Objectives: Qualification of the integration of the power system with components of advanced life support systems that will utilize the waste heat from the power system.
    - b. Key Techniques: Life support components that can utilize waste heat of the isotope power supply (such as evaporators and stills) will be integrated with heat sources from the power system and operated in a zero-g environment. Life support components are (1) CO<sub>2</sub> concentrator (molecular sieve) and (2) water purification still.
  - 3.2 MEASUREMENT AND DATA:
    - a. Phenomena and Characteristics to be Measured: Sufficient data will be taken at regular intervals in the form of temperature, pressure, humidity, flow rates and power consumption for the purpose of computing mass and energy balances for the various life support components. In addition, CO<sub>2</sub> partial pressure measurements will be taken to evaluate performance of the CO<sub>2</sub> concentrator. Purified water will be measured for electrical conductivity and pH at two locations: (1) as it comes from the still and (2) in a storage vessel where it is collected over a period of time. RTEG output voltage and current as well as fuel block hot and cold junction and radiator inlet/outlet temperatures will be monitored to evaluate performance and detect abnormal operating conditions.
    - b. Instrument Resolution: N/A

3.3 FLIGHT REGIME:

- a. Orbital Parameters: No restrictions.
- b. In-Flight Duration of Experiment: N/A.
- c. Seasonal, Launch-Date Requirements: None.
- d. Desired Flight Characteristics: Not sensitive to these.
- e. Reasons for Orbital Requirements: N/A.

3.4 SUPPORT EXPERIMENTATION:

- a. Simultaneous Earth/Space Observations: Continuous monitoring of orbit characteristics will be required in order to assure heat source recovery under all circumstances.
- b. Prerequisite Earth/Space Experimentation: Comprehensive system testing (power system plus life support components) will be required in ground facilities prior to orbital test. Tests to subject a simulated heat source to launch pad fire, launch abort, uncontrolled reentry, etc. will be required.

4. OPERATIONS:

4.1 DUTY CYCLE:

- a. Number and Duration of Operating Periods: Continuous for mission.
- b. Estimated Interval Between Operating Periods: N/A.

4.2 CREW REQUIREMENTS:

- a. Requirements for Crew Participation: Crew participation is not essential to this experiment. It would, however, greatly enhance the amount of data that could be obtained. It would also make possible the test of a catalytic contaminant control reactor with the other life support components and extend test time.
- b. Description of Crew Involvement: Water samples could be taken and stored for analysis on Earth.

Chromatographs and spectrometers could be operated to obtain a much more complete analysis of gas processed through the catalytic reactor and CO<sub>2</sub> concentrator. Crew participation would minimize the need for automatic control mechanisms, permit more effective utilization of instruments and recording devices, and provide normal maintenance of equipment. Crew time estimates are: checkout, 5 minutes, and experimentation, 1½ hours/day.

## 5. APPARATUS DESCRIPTION:

### 5.1 METHODS OF MEASUREMENT AND SENSOR DESCRIPTION:

- a. Methods of Measurement: Normal monitoring equipment required for life support subsystems will include thermocouples, pressure sensors, flowmeters, hygrometer, CO<sub>2</sub> partial pressure sensor, voltmeter, and ammeter. RTEG performance and operating conditions will be monitored using thermocouples and voltage and current sensors. If crew participation is included, gas analysis will extend to the use of a gas chromatograph, mass spectrometer, and an infrared spectrometer.
- b. Sensor Description: The sensors will include the list of equipment tabulated in Table A.1-1 in addition to a complement of temperature, pressure, and flow measuring devices. Equipment stored and operating sizes are the same. The pertinent sensor characteristics are included in Table A.1-1.

### 5.2 DATA COLLECTION:

- a. Format: Unknown, probably magnetic tape or some type of film recordings.
- b. Total Bulk of Data: It is estimated that 300-1000 bits of data will be recorded per orbit. In addition a small number of bits would be hand recorded if there is crew participation.
- c. Necessity for Recovery: It is expected that there will be a requirement to recover the RTEG. Also, water samples taken in the case of crew participation will be recovered.

- 5.3 ANCILLARY EQUIPMENT: There may be a requirement to supply the water and atmosphere for the life support components, particularly if the experiment is on an unmanned vehicle. If the experiment is on a manned vehicle, it is expected that atmosphere and water from the crew compartment would be utilized.
6. CONCEPTUAL DESIGN: See Figure A.1-1.

Table A.1-1 SENSOR CHARACTERISTICS

Equipment Name	Size (in.)	Weight (lb.)	Power (Watts)	Development status	Reliability	Environmental Considerations
RTEG (500 watt module)	19 x 10 x 24	155	Delivers 500 watts	125 watt unit built, not for space. Matls. & SOA		Shield of crew against $\alpha$ & $\gamma$ Radiation 3-6 REM over 45-to day mission anticipated dissipate approx. 2400 BTU/HR cont. 2000°F.
Radiator	75 ft <sup>2</sup>	75	---	New design but radiators have been built		Must view space during entire mission. May view higher temp. (than 300°F) for short periods.
Pumps (2) Ea.	2.5D x 5	3	40 watt	Existing Component		Operate at Fluid temperature
Radiation shield	?	100	---	SOA design		---
ECS Heat exchanger	4 x 6 x 10	10	---	SOA, New design		Associated with RTEG pressurized
ECS pumps ea. (2)	2.5D x 5	3	40 watt	Existing Component		Operate at Fluid temperature 400°F, pressurized
CO <sub>2</sub> concn.	30 x 30 x 24	120	4 watt cont. 20 watt, int.	Modification of development unit to use waste heat		Operate from 75 - 160°F, pressurized.



Table A.1-1 SENSOR CHARACTERISTICS  
(Sheet 2)

Equipment Name	Size in.	Weight lb.	Power Watts	Development status	Reliability	Environmental Considerations
H <sub>2</sub> O evaporator	24 x 24 x 12	50	4 watt 7 watt	cont. In development, modify to use waste heat		Requires cooling at approx. 100°F, 4,000 BTU/HR, pressurized
Catalytic React.*	8 x 4 x 4	11	---	Modify existing unit to use waste heat		400°F, insulated pressurized
Gas chromatograph	600 in <sup>3</sup>	10	10	Existing Component		Inside Crew Compartment, pressurized
Mass Spectrometer	900 in <sup>3</sup>	15	25	Existing Component		"
Infra-red spectrometer	1090 in <sup>3</sup>	15	25	Existing Component		"

\*Used if crew participation only.

**NOTES**

- VOLUMES (IN<sup>3</sup>):  
 BASIC COMPONENTS INSTALLED: 50,900  
 127,000  
 1031
- TOTAL MASS (LBS): 50,900
- CRITICAL COMPONENT SHAPES:  
 A - 30 IN X 30 IN X 24 IN.  
 B - RADIATOR REQUIRES 75 FT<sup>2</sup> EXPOSED SURFACE AREA (SHAPE IS FRUSTUM OF CONE W/DIAMETERS OF 4 FT. & 2 FT. & HEIGHT 3 FT.)
- 60-DAY LIFETIME IN ORBIT
- EXPERIMENT PACKAGE EJECTED FOR OPERATION
- ACCESS REQUIRED TO INSTALL HEAT BLOCK (STG) JUST PRIOR TO LAUNCH
- AUXILIARY COOLING REQUIRED FOR RTG: PRELAUNCH - EXTERNAL HEAT EXCHANGER (H.O.) LAUNCH - WATER BOILER (I.R. RADIATOR) ORIENTATION - LAUNCH VEHICLE
- ORIENTATION - LAUNCH VEHICLE  
 UNMANNED - NO RESTRICTION  
 MANNED VEHICLE - RADIATION SHIELD MUST BE POSITIONED BETWEEN VEHICLE AND RTG MODULE
- RTG MODULE  
 MID-DISK DISPOSITION AT EXPERIMENT TERMINATION ASSUMED TO BE EXHAUSTIVE DESTRUCTION (SOME QUESTION REMAINS AT THIS TIME AS TO THE VALUE OF THE ABOVE ASSUMPTION.)
- NO SIZE PARTICIPATION
- ALL DATA TELEMETRED - NO PHYSICAL RECOVERY OF EXP. SAMPLES
- ALL PRIMARY EQUIPMENT: WATER, VENTILATION, ETC. SUPPLIES NOT INCLUDED.

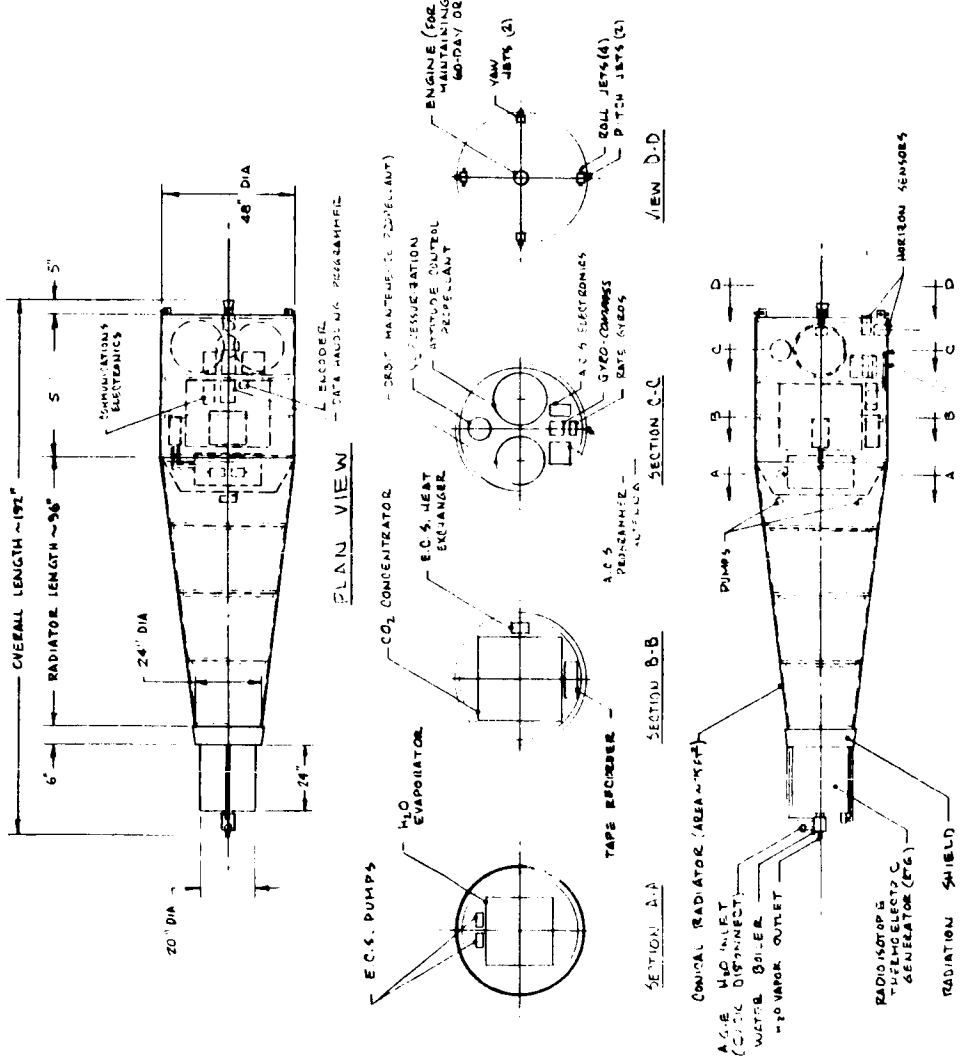

EXPERIMENT	SDT-1
RADIOISOTOPE - THERMOELECTRIC POWER SYSTEM INTEGRATION	
1/40 SCALE	G.F. GIBSON 9-30-65

Figure A.1-1 SDT-1 CONCEPTUAL DESIGN DRAWING

1. EXPERIMENT SDT-2: Performance Assessment of Thin-Film Solar Cell Arrays.

2. TECHNICAL AREA/APPLICATIONS:

2.1 GENERAL AREA: Systems Development and Test

2.2 EXPERIMENT APPLICATIONS: To verify the performance characteristics of thin-film solar cells in the space environment.

3. EXPERIMENT OBJECTIVES AND SCOPE:

3.1 OBJECTIVES:

a. Specific Objectives: To determine the response of cadmium-sulfide and other thin-film photovoltaic cells to the combined effects of free space environments with emphasis on sunlight, high-energy electron and proton radiation, and micrometeoroid impingement.

b. Key Techniques: The thin-film solar cell experiment will be performed by ejecting an experiment package and modifying its orbit to a minimum of 300 n.mi.perigee, after which a release mechanism will be operated to erect three mutually perpendicular collector panels. The package will be permitted to tumble at random in space. Quality of performance will be based upon a comparison with the output of standard silicon cells mounted on the vehicle in positions parallel to the plane of each test specimen. The test panels will be arranged to form a power system in conjunction with a nickel-cadmium battery and voltage control unit. Energy for the operation of the monitoring, communication and other satellite systems will be supplied by the test panels:

3.2 MEASUREMENTS AND DATA:

a. Data to be measured include:

(1) Current output of each of the six test and six standard photovoltaic cell panels

SDT-2  
(Sheet 2)

- (2) Combined array output voltage
- (3) System output voltage and current
- (4) Temperature of each of the test and standard photovoltaic panels
- (5) A simple radiation monitoring device would add to the significance of test results, but is not essential.

b. Instrumentation resolution required:

- (1)  $\pm 0.5$  volt and  $\pm 0.1$  ampere or better
- (2)  $\pm 2^{\circ}\text{F}$  temperature
- (3) Radiation level optional, depending on convenience and availability

Data sampling rate of once per minute is adequate. Numbers of parameters are approximately as follows. Voltages, 2; currents, 13; and temperatures, 12. Total parameters 27; 8 bits each of 216 bits per minute.

3.3 FLIGHT REGIME:

- a. Orbital Parameters: A minimum of 300 n.mi. perigee at an inclination of 30 or more degrees is desired to assure exposure to the radiation belts.
- b. Duration: One-year orbit desired.
- c. Seasonal Requirements: Time of season of launch optional.

3.4 SUPPORT EXPERIMENTATION:

Earth support is limited to that of data reception.

4. OPERATIONS:

DUTY CYCLE:

Degradation of the thin-film solar array is a continuous process. Documentation consists of interrogation performed for periods of 10 to 30 minutes at weekly intervals.

4.2 CREW REQUIREMENTS: None

5. APPARATUS DESCRIPTION:

The experiment apparatus is illustrated in Figure A.1-2. In the stowed position, the experiment package is 6 x 6 x 72 inches and is divided into four near equal compartments of 3 x 6 x 36 inches. One compartment houses a battery, voltage controller, data automation, and communication equipment. The other three compartments house collapsed thin-film solar array elements. Each array element is constructed about five, 4-inch-diameter flexible plastic tubes five feet in length. The tubes are joined together at the sides to form an "air mattress" type of assembly. A 2.3-x 4.5-foot thin-film collector is attached to the tangent surface of the five plastic tubes. The entire assembly is rolled and stowed as illustrated in sections M-N and P-Q of Figure A.1-2. The stowed enclosure is covered by a sealed membrane and filled with a dry gas to prevent moist air from contacting the thin-film arrays.

The array which deploys in the XZ plane is housed in enclosure AB. When the operational orbit is achieved, the first step in the deployment procedure involves the operation of a release to permit segment AB to spring out to a position perpendicular to the main assembly body AD. At that time, three gas generators are triggered, filling each "air mattress" and extending the arrays. Last, a form technique is applied to rigidize the assemblies.

Apparatus summary data:

- (1) Equipment name: Thin-film solar collector.
- (2) Equipment size stored: 6 x 6 x 72 inches.
- (3) Equipment size operating: 7.5 x 10 x 5 feet.
- (4) Equipment weights:
  - (a) Test solar collectors: 1.2 pounds each or 7.2 pounds total. This is active portion only. It does not include plastic tubes, inflation mechanism, structure, etc.

- (b) Standard cells: 0.03 pound each, or 0.18 pound total.
- (c) Nickel-cadmium battery, 28-volt, 1.9-ampere-hour, composed of 24 D size sealed cells; each cell is 1.33 inches in diameter and 2.4 inches high and weighs 5.5 grams. Battery is assembly 5.4 x 8.1 x 2.75 inches and weighs 9.25 pounds.
- (d) Voltage and charge rate control unit 2 x 3 x 3.5 inches, 1.24 pounds.
- (5) The thin-film test array and battery combination will produce 10 watts continuously with pulse capabilities to 50 watts. The power is available to operate the monitoring, data processing, and communication system.
- (6) Environment limitations apply to the battery which should be maintained within the 0 to 100°F range. The effect of unaltered space environment on the array is the prime purpose of the experiment.
- (7) Frequency spectrum: N/A.
- (8) Accuracy consideration: N/A.
- (9) No orientation required, however an attitude control system would be required to position the package prior to firing a booster to achieve the 300 n.m. orbit.
- (10) Development status: Available now.
- (11) Reliability data is one of the goals of the experiment.

6. CONCEPTUAL DESIGN: See Figure A.1-3.

PACKAGE FOLDED 6" x 6" x 72"

FOLDED ARRANGEMENT:

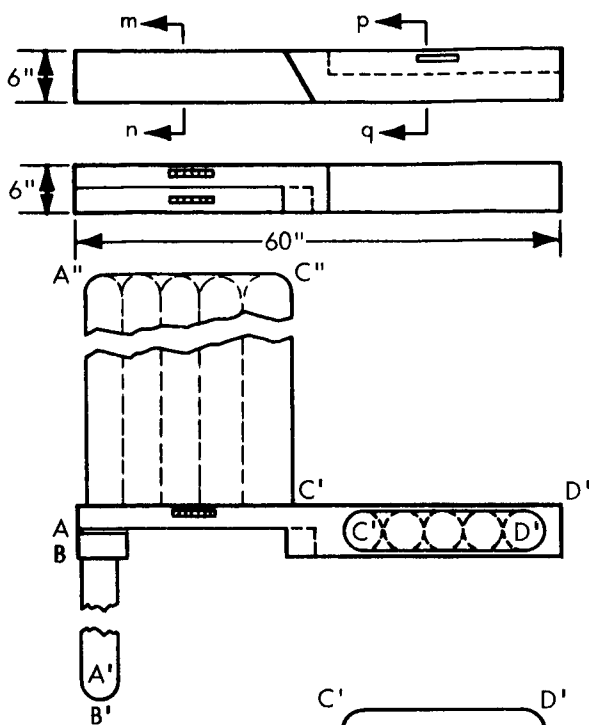

ABA'B' XZ PLANE COLLECTOR  
 AC A''C'' XY PLANE COLLECTOR

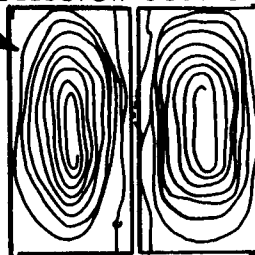

SECTION m-n

CDC'D' - ZY PLANE COLLECTOR

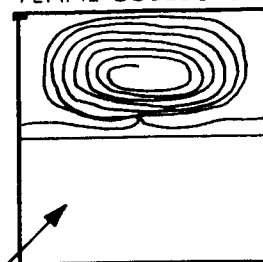

SECTION p-q

3" x 6" x 36"  
 STORAGE BAT.  
 DATA AUTOMATION  
 & COMMUNICATION  
 EQUIP. COMP.

Rolled collectors stored within a sealed enclosure by a rupturable diaphragm. Collectors are extended by inflating 5 plastic tubes which are rigidized with foam. Each collector expose 10 Sq. Ft. of thin film on each surface

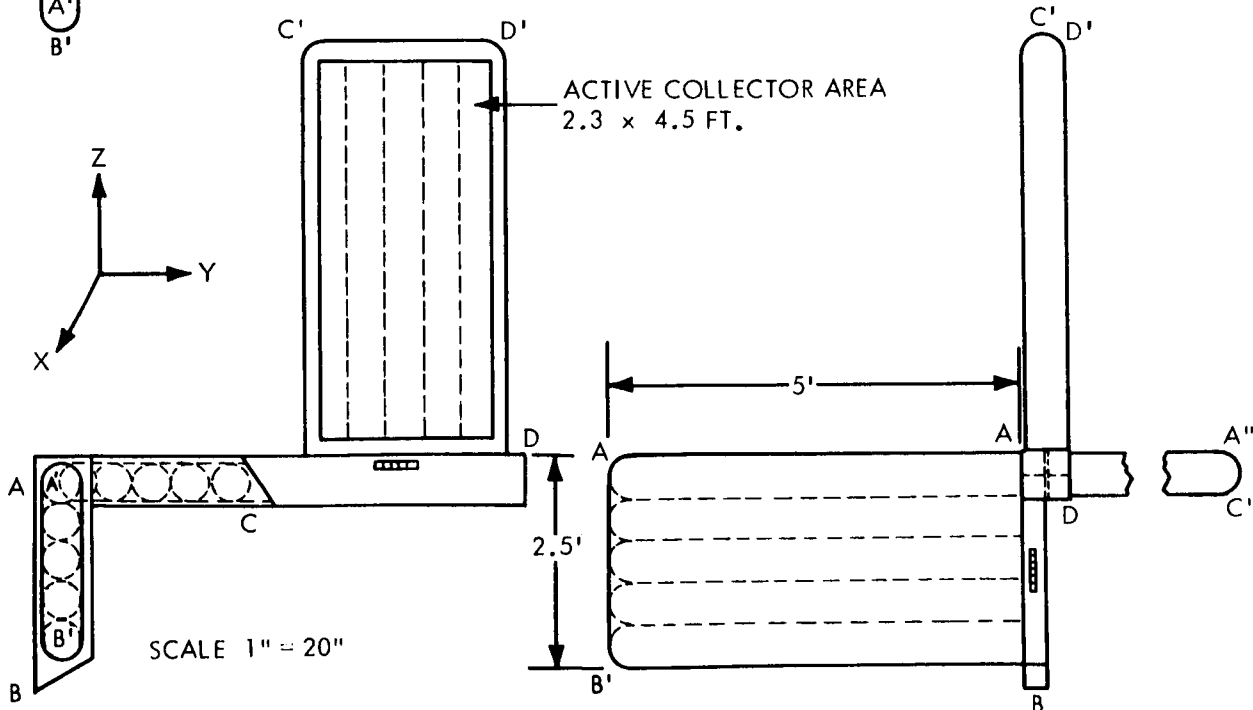

Figure A.1-2 SDT-2 THIN-FILM CADMIUM - SULPHIDE PHOTOVOLTAIC IN-FLIGHT EXPERIMENT PACKAGE

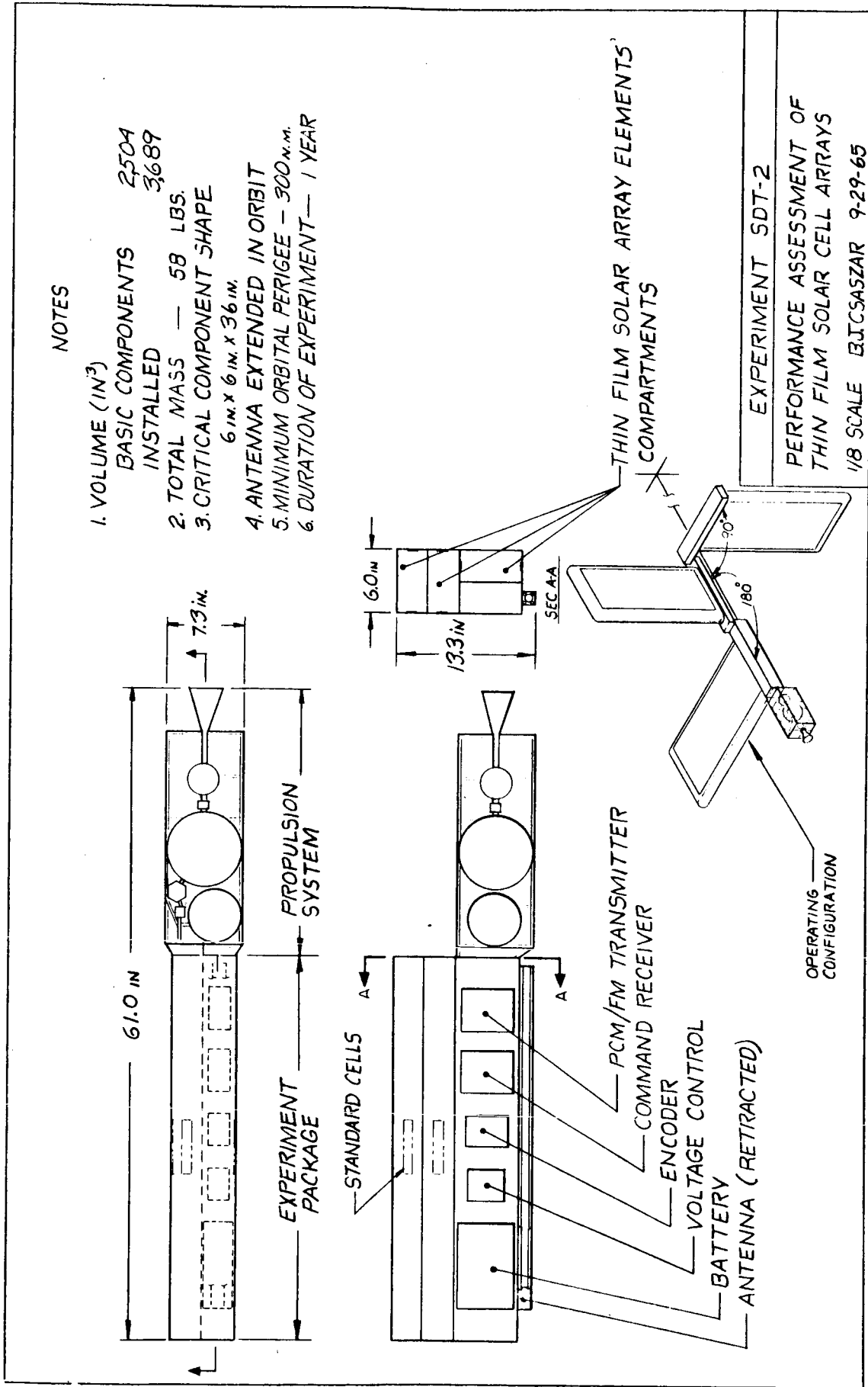

Figure A.1-3 SDT-2 CONCEPTUAL DESIGN DRAWING



1. EXPERIMENT SDT-3: Performance Assessment of Spacecraft Navigation, Guidance and Control Hardware, and Techniques.
2. TECHNICAL AREA/APPLICATIONS:
  - 2.1 GENERAL AREA: Systems Development and Test.
  - 2.2 EXPERIMENT APPLICATION: To demonstrate the practicality and evaluate the performance of "on-board" space flight navigation, guidance, and control hardware and software which requires a minimum of astronaut attention. The tests are to be conducted within the environment of an Earth satellite vehicle.
3. EXPERIMENT OBJECTIVES AND SCOPE:
  - 3.1 OBJECTIVES:
    - a. Specific Objectives: The objective of this group of experiments is to investigate the feasibility of a self-contained space navigation system. It is felt that fully self-contained navigation systems have a vast potential for the space missions of the future. This experiment is designed to evaluate the individual component techniques, complete systems, and the navigation and guidance software. These investigations will be conducted under the constraint that they involve as little of the astronaut's time as possible. This does not imply that the techniques and systems envisioned for on-board space navigation must be fully automatic in operation. It only implies that the experiments to demonstrate feasibility and performance should be designed to occupy a second role on manned orbital flights of the near future. However, the entire experiment could be ejected as a separate orbiting satellite. The possibility of fully automatic and self-contained systems for space flight is a natural extension of the technology required for any on-board navigation system. It may be feasible eventually, to provide such a system which will require only a minimum of human monitoring and maintenance. This experiment is actually a series of sub-experiments covering the individual sensors, both inertial and

electromagnetic, and finally an autonomous space navigation system.

b. Key Techniques: This experiment will consist of three primary parts as follows:

- (1) Evaluation of electromagnetic sensors and techniques (to include sun trackers, star trackers, sextants, and the like).
- (2) Evaluation of an inertial measurement unit.
- (3) Evaluation of the complete, self-contained navigation system.

The tests will involve the guidance and navigation hardware in several configurations and various operating modes. The electromagnetic sensors experiment will be designed to test the feasibility of the sensor, the interface with the spacecraft and the functional performance in making a variety of measurements, for the following sensors:

- (1) Planet trackers
- (2) Star trackers
- (3) Sun sensors
- (4) Automatic sextants.

The measurements to be made include (1) sun, star, and planet elevation and relative bearing and (2) the included angles measured at the spacecraft between lines of sight to the sun and a star, a planet edge and a star, a lunar or planetary landmark and a star, and others. In the case of the horizon scanner set, the outputs will consist of planetary angular diameters and local vertical determinations. These measurements will be implemented by a computer of some type which receives attitude and position data from the primary spacecraft system and programs the various sensors to acquire their objectives and carry out the measurements. Automatic recording of measurements along with time and spacecraft position

and attitude will be required. In this manner, a minimum of astronaut involvement will be required. The attitude changes required to facilitate the experiment can be performed by the astronaut or may be tied in with the sensor control computer, permitting automatic attitude changes. Without use of the sensor control computer, a larger part of the experiment task must be performed by the astronaut.

The best measure of sensor performance in terms of angular resolution is obtained through laboratory methods or indirectly through the accuracy of state estimation based on the angular measurements. Since this phase of the experiment does not involve data processing and navigational computations, no accurate measure of sensor errors is envisioned.

The inertial measurement unit experiment will be designed to test the feasibility and performance of an inertial reference unit and horizon scanner system to determine spacecraft attitude and to monitor thrust applications. The platform will be leveled through tie-in to the horizon scanner and aligned to the orbit plane by orbital gyrocompassing. Attitude is then referenced to the orbit plane and the local vertical. During thrust applications, the local vertical leveling is stopped and the platform operates as a pure inertial reference with coordinates defined by the orbit azimuth and local vertical at the initial point of the thrust application.

The on-board navigation system experiments are designed to compare the performance of the self-contained, on-board system to determine spacecraft attitude, position, and velocity with the performance of ground-based systems. The complete system may be configured in several ways depending on what sensors are used.

### 3.2 MEASUREMENTS AND DATA

#### a. Types of measurements to be made:

SDT-3  
(Sheet 4)

- (1) With respect to the individual sensor tests, the following measurements should be made:
  - (a) Altitude and relative bearing for star tracker, sun tracker, planet trackers.
  - (b) Angles included between two lines of sight for automatic sextant.
- (2) With respect to the inertial measurement unit tests, the following measurements should be made:
  - (a) Spacecraft attitude
  - (b) Gyrocompass time
  - (c) Acceleration (during thrust)
  - (d) Velocity changes
- (3) With respect to the autonomous navigation system tests, the following measurements should be made:
  - (a) Estimated position
  - (b) Estimated velocity
  - (c) Attitude
  - (d) Time
  - (e) Acceleration levels and  $\Delta V$  during thrust maneuvers.

b. Measurement resolution required

- (1) All angular measurements should be made to the highest precision possible with the sensors being used. The recording accuracies should be compatible with the sensor being used. In general, the recording device should be capable of arc-second precision.

- (2) Acceleration or deceleration levels from  $10^{-5}$  to 1 g with accuracy of  $\sim 10^{-6}$ g.
- (3) Velocity changes from 0.1 fps to 100 fps with an accuracy of 0.01 fps.
- (4) Time: 1 part in  $10^{10}$ .
- (5) Position and velocity estimates are to be made with the highest precision possible with the sensors and software employed. Recording must be accurate to 0.01 n.mi. in position and 0.01 fps in velocity.

### 3.3 FLIGHT REGIME:

- a. **Orbital Parameters:** There are not firm requirements as to specific orbit parameters needed for these tests. In general, any satellite orbit of low eccentricity ( $e < .05$ ) and with inclination of  $\sim 30^\circ$  will satisfy the requirements.
- b. **Duration:** The required orbital duration varies from 5-7 days for the sensor and IMU tests to a minimum of 14 days for the full system tests.
- c. **Seasonal Requirements:** None
- d. **Other Flight Requirements:** It is desirable for the IMU and full system tests that a vehicle be used which has some orbit change capability.
- e. **Reasons:** To efficiently conduct the three phases of this experiment, three flights should be used.

### 3.4 SUPPORT EXPERIMENTATION:

- a. **Simultaneous Activity:** The third phase of this experiment in which the complete, autonomous navigation system is exercised requires periodic tracking and orbit determination by ground-based facilities for purposes of comparison with on-board system estimates.

- b. Prerequisite Experimentation: No requirement exists for prerequisite Earth/Space experimentation in direct support of this experiment.

#### 4. OPERATIONS:

##### 4.1 DUTY CYCLE:

Wide latitude may be exercised in the scheduling of test periods within the flight itself and in the duration of the tests. In general, the tests may be conducted any time that primary mission functions do not preclude the achievement of the spacecraft attitude which may be required to operate certain sensors. Since operation of the experiment equipments involves very little of the astronaut's time, it is likely that the experiments may be run concurrent with primary mission operations. Individual test durations on the sensor and IMU investigations will require a minimum of 30 minutes at a time with a total operate time over the entire flight of from 10 to 30 hours.

##### 4.2 CREW REQUIREMENTS:

Crew involvement is slight for all phases of this experiment. Some attitude maneuvering may be required to bring certain sensors into proper orientation prior to experiment periods. The astronaut will then be required to initiate the experiment but will not need to further assist or monitor the experiment. The entire experiment could be ejected as a separate orbiting satellite.

#### 5. APPARATUS DESCRIPTION:

##### 5.1 METHODS OF MEASUREMENT AND SENSOR DESCRIPTION:

- a. Methods of Measurement: The hardware being investigated under this experiment is largely measuring devices, and their normal outputs are the data of interest to the experiment. These measurements are the angles from the sextant, the sun tracker, the star trackers and horizon scanners, plus the acceleration measurements from the IMU. Other derived quantities such as  $\Delta V$  and the spacecraft position and velocity must be recorded.

SDT-3  
(Sheet 7)

- b. Sensor Description: The equipment physical characteristics and parameters are shown in Table A.1-2.
- c. Equipment Required per Phase (see attached table):
  - (1) Experiment phase one requires equipment items 1,2,3,4,5,6,11.
  - (2) Experiment phase two requires equipment items 6,7,8,9,11.
  - (3) Experiment phase three requires equipment items 1,3,4,5,6,7,8,9,10,11.

5.2 DATA COLLECTION:

- a. Format: Data is to be recorded with an automatic tape recording device provided as a part of the experiment hardware.
- b. Amount: Total data to be recorded will run  $0.5 \times 10^6$  bits per experiment phase or a grand total of 1.5 million bits.

- 6. CONCEPTUAL DESIGN: See Figure A.1-4.

TABLE A.1-2  
SDT-3 SIGNIFICANT PHYSICAL CHARACTERISTICS

Name	Size (Stored)	Size (In Operation)	Weight	Power	Duty Cycle	Environmental Parameters	Devel. Status	Reliability	Phase One	Phase Two	Phase Three
1 Star Tracker	12x12x12	12x12x12	25	5	50%	0°-150°F			x		x
2 Planet Tracker	10x10x12	10x10x12	25	5	50%	0°-150°F			x		
3 Tracker Electronics	10x8x8	10x8x8	20	10	Cont.	0°-120°F			x		x
4 automatic sextant	15x10x12	15x10x12	20	5	25%	0°-150°F			x		x
5 sextant electronics	10x8x8	10x8x8	20	10	25%	0°-120°F			x		x
6 experiment control computer	14x12x10	14x12x10	30	25	Cont.	35°-120°F			x	x	x
7 IMU	12x10x10	12x10x10	25	100	Cont.	temp. control req. by forced air, 40°-80°F				x	x
8 IMU electronics	10x8x8	10x8x8	20	40	Cont.	0°-120°F				x	x
9 horizon scanner	10x5x6	10x5x6	15	10	Cont.	10°-140°F				x	x
10 digital computer	14x10x8	14x10x8	30	50	Cont.	0°-120°F					x
11 tape recorder unit	12x8x5	12x8x5	15	15	Cont.	35°-120°F			x	x	x



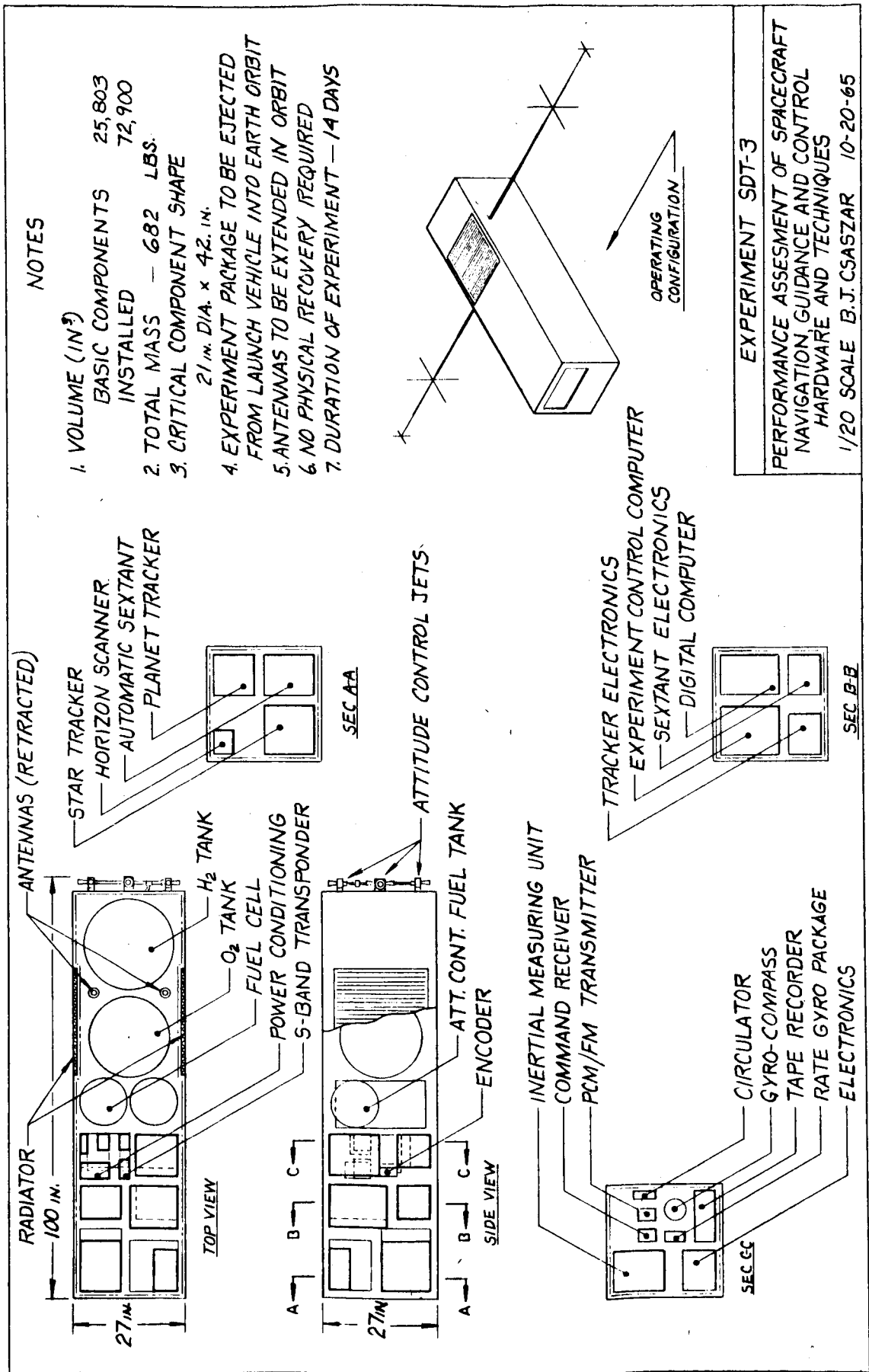

Figure A.1-4 SDT-3 CONCEPTUAL DESIGN DRAWING

1. EXPERIMENT SDT-4: Cryogenic Propellant Storage System Performance
2. TECHNICAL AREA/APPLICATIONS:
  - 2.1 GENERAL AREA: Systems Development and Test
  - 2.2 EXPERIMENT APPLICATIONS: To evaluate the performance of certain cryogenic propellant storage systems.
3. EXPERIMENT OBJECTIVES AND SCOPE:
  - 3.1 OBJECTIVES:
    - a. Specific Objectives:
      - (1) To determine the effectiveness of super-insulation in reducing the heat transfer to cryogenic propellants.
      - (2) To determine the degree of stratification within the propellant tank.
      - (3) To evaluate the performance of an ullage orientation system for reduction of propellant stratification.
    - b. Key Techniques: A series of experiments will be performed to measure the heat transfer to LH<sub>2</sub> in a superinsulated tank by measuring the boil-off. Measurements will also be taken to determine the level of stratification within the tank and to evaluate stratification reduction by means of ullage orientation. The experiment package will be ejected from the launch vehicle after orbit is attained and will orbit alone with its own attitude-control system.
  - 3.2 MEASUREMENTS AND DATA:
    - a. Phenomena to be Measured: Measurements of temperature, tank pressure, flow rate (of boil-off), and tank acceleration will be taken at intervals to meet the objectives of the experiment. In particular, sufficient temperature

measurements must be obtained within the tank to establish the degree of stratification. Pressure and flow rate measurements, combined with the temperature measurements, will establish the heating rate and the accuracy of the heat balance. Tank-wall temperatures will be obtained for comparison with predicted values. Finally, tank acceleration will be measured to compare the stratification measurements with predictions.

- b. Resolution: Temperature and pressure measurements at approximately 2-minute intervals.

### 3.3 FLIGHT REGIME:

- a. Orbital Parameters: Terminator orbit required; circular orbit is desirable.
- b. In-Flight Duration of Experiment: 3 to 4 days at minimum; longer duration desirable but will be limited by power requirements.
- c. Launch Date Requirements: None
- d. Desired Flight Characteristics: After ejection of the experiment package, orientation of the propellant tank along the velocity vector will be required.
- e. Reasons for Above Orbital Requirements: Long flight duration is necessary to permit stratification of propellant. Orientation requirement is necessary to allow accurate prediction of heat transfer for comparison purposes.

### 3.4 SUPPORT EXPERIMENTATION:

- a. Simultaneous Earth/Space Observations: Monitoring of orbit characteristics will be required.
- b. Prerequisite Earth/Space Experimentation: Not applicable.

## 4. OPERATIONS:

### 4.1 DUTY CYCLE:

- a. Number and Duration of Operational Periods:  
The experiment will run continuously beginning with ejection from the orbiting portion of the launch vehicle. The overall experiment comprises several small experiments that will be conducted in the following operational sequence:
- (1) Orbit injection of parent vehicle.
  - (2) Experiment package ejected (no propulsion system).
  - (3) Orientation of superinsulated tank with longitudinal axis along the velocity vector.
  - (4) Ullage orientation and venting to establish initial conditions.
  - (5) Stratification measurements.
  - (6) Stratification reduction by ullage orientation.
  - (7) Ullage orientation and venting back to initial pressure with simultaneous measurement of boil-off flow rate.
- b. Estimated Interval Between Operating Periods:  
Not applicable.

#### 4.2 CREW REQUIREMENTS:

- a. Crew Participation: Not required.
- b. Crew Involvement: Not applicable.

#### 5. APPARATUS DESCRIPTION:

##### 5.1 METHODS OF MEASUREMENT AND SENSOR DESCRIPTION:

- a. Methods of Measurement: Monitoring equipment will include thermocouples, pressure sensors, flow meters, and accelerometers.

- b. **Sensor Description:** The experimental apparatus includes that described in the attached table in addition to the temperature, pressure, flow, and acceleration measuring devices. Equipment-stored and-operating sizes are the same.

5.2 **DATA COLLECTION:**

- a. **Format:** Magnetic tape
- b. **Total Bulk of Data:** 500 to 1000 bits/orbit
- c. **Necessity of Recovery:** No requirement for recovery of any portion of the experiment package.

5.3 **ANCILLARY EQUIPMENT:** Data recorders will be required and equipment to relay the data to the Earth receiving station.

6. **CONCEPTUAL DESIGN:** See Figure A.1-5.

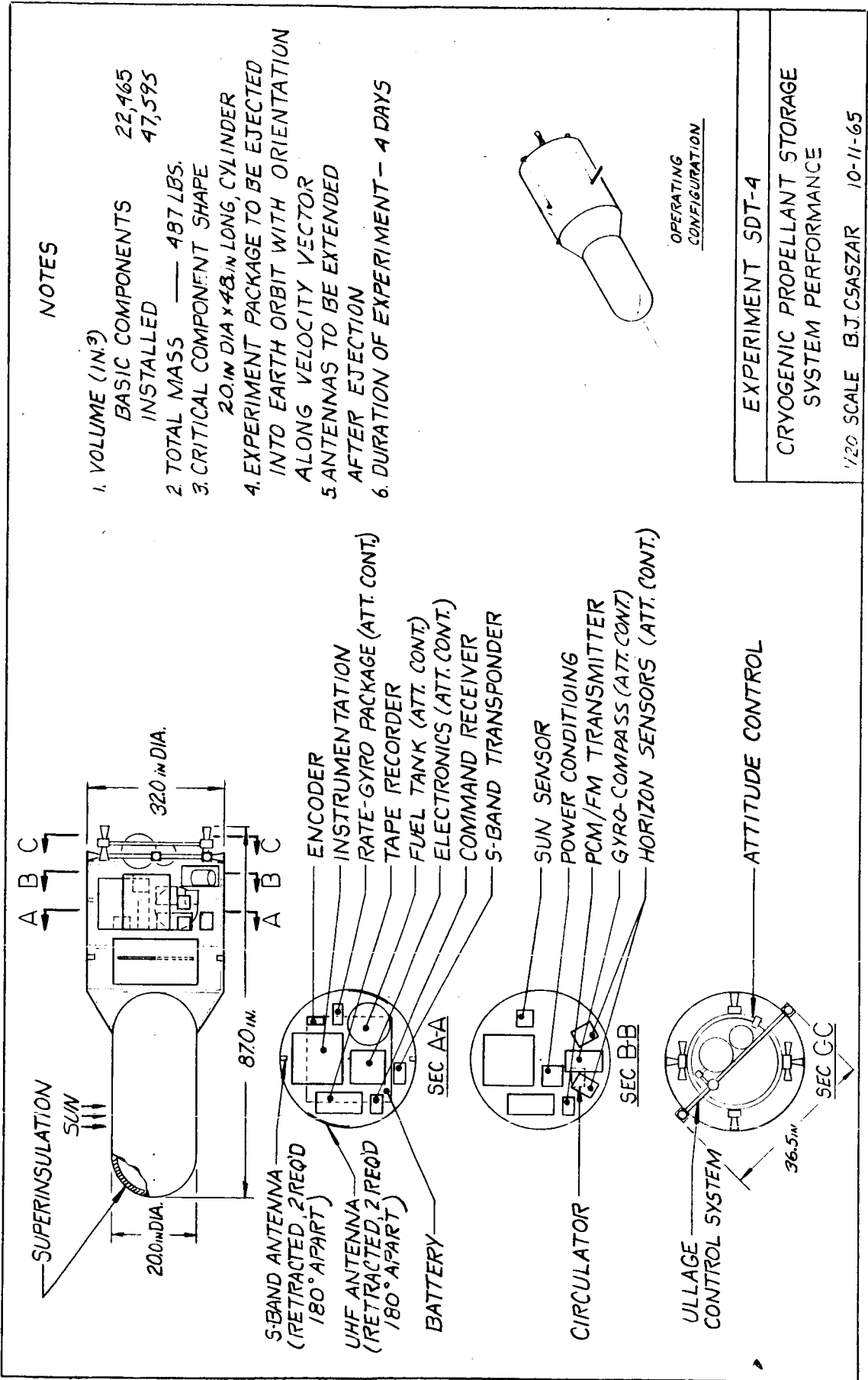

Figure A.1-5 SDT-4 CONCEPTUAL DESIGN DRAWING

1. EXPERIMENT SDT-5: Launch of Unmanned Satellites and Probes
2. TECHNICAL AREA/APPLICATIONS:
  - 2.1 GENERAL AREA: Systems Development and Test
  - 2.2 EXPERIMENT APPLICATIONS: To provide free ride and ejection of one or more unmanned satellites and probes, including the following types.
    - (1) COMSATS
    - (2) Applications Technology Satellites
    - (3) Topside Sounders
    - (4) Advanced Weather Satellites
    - (5) Advanced Orbiting Solar Observatories
    - (6) Orbiting Geophysical Observatories
    - (7) Orbiting Astronomical Observatories
    - (8) Advanced Navigational and Geodetic Satellites
    - (9) Air Density-Injun Explorers
    - (10) Advanced Nuclear Event Detection Satellites
    - (11) Advanced Special-Purpose Satellites
    - (12) Micrometeoroid Detection Satellites
    - (13) Magnetosphere Explorers
    - (14) Energetic Particles Explorers
    - (15) Biosatellites
3. EXPERIMENT OBJECTIVES AND SCOPE:
  - 3.1 OBJECTIVES:

- a. **Specific Objectives:** To provide a portion of the boost trajectory of one or more auxiliary pickaback satellites as a secondary and autonomous part or parts of a large payload to achieve a considerable reduction in the expenses of individual satellite launches.
- b. **Key Techniques:** The auxiliary pickaback satellites will be fitted with the necessary propulsion and guidance systems which will be used to transfer the pickaback satellites from the "parking" orbit achieved by the SIU-SIVB booster systems to the desired orbits of the individual satellites. The pickaback satellite/third-stage booster packages will be mounted on erectable or fixed launch platforms installed on or in the SIU-SIVB structure. After reasonable separation of the CM-SM-LEM and the SIU-SIVB components, the launch platforms will be erected, and the pickaback satellite packages will be readied for launch. Through the use of the normal satellite tracking and data handling facilities, the parking orbit parameters of the SIU-SIVB vehicle and the appropriate launch points for the separate pickaback satellites will be determined. The launch sequence for the individual satellites will be initiated on ground command. Visual verification of the separate launches could be performed by the crew in the CM-SM-LEM vehicle.

### 3.2 MEASUREMENTS AND DATA:

- a. **Phenomena to be Observed:** The measurements and data acquired by the operation of the individual pickaback satellites will take place subsequent to their launch and separation from the SIU-SIVB stage. Acquisition of the satellite data will be accomplished by use of normal satellite tracking and data handling facilities.
- b. **Measurement Rate Accuracy:** N/A.

### 3.3 FLIGHT REGIME:

- a. **Orbital Parameters:** The orbital parameters of the SIU-SIVB stage must be such that the parking orbit



does indeed exist for more than a small fraction of an orbit. The launch requirements of most of the pickaback satellites could be satisfied within one orbit of the SIU-SIVB stage. The necessary propulsion to be included as a third-stage booster package on the individual satellites will be sized as a function of the orbital parameters of the parking orbit, the desired orbital parameters of the individual satellites, and the masses of the satellites. The desired orbital parameters and the masses of the individual satellites are given in paragraph 5.1.

- b. Duration: See Item 3.3-a.
- c. Seasonal Requirements: The launch of individual satellites might be keyed to seasonal and solar cycle variations and to such a periodic activity as the IGY and the IQSY.
- d. Other Flight Characteristics: See Item 3.3-a.
- e. Reasons: See Item 3.3-a.

#### 3.4 SUPPORT EXPERIMENTATION:

- a. Simultaneous Activity: Through the use of the normal satellite tracking and data handling facilities, the parking orbit parameters of the SIU-SIVB stage and the appropriate "launch" points for the separate pickaback satellites will be determined. The launch sequence for the individual satellites will be initiated on ground command. The measurements and data acquired by the operation of the individual pickaback satellites will take place subsequent to their launch and separation from the SIU-SIVB stage. Acquisition of the satellite data will be accomplished by use of the normal satellite tracking and data handling facilities. In this regard, there is the possibility that the ground tracking and data handling requirements of the primary mission could conflict with the corresponding requirements of the secondary satellites.

b. Prerequisite Experimentation:

4. OPERATIONS:

4.1 DUTY CYCLE:

- a. Operational Periods: The duration of the operational period as far as the SIU-SIVB stage is concerned would be the duration of the parking orbit (i.e., less than the first 90 minutes of the SIVB orbit, in most cases).
- b. Interval: There is no operational period required of the SIU-SIVB stage after launch of the pickaback satellites.

4.2 CREW REQUIREMENTS:

- a. Astronaut Participation: Astronaut participation is not required. Visual verification of the SIU-SIVB attitude stability, pickaback launch platform erection, and the separate launches of the individual satellites could be performed by the crew in the CM while the SIU-SIVB stage was still in view, but such verification would not enhance experiment effectiveness.
- b. Crew Involvement: See Item a.

5. APPARATUS DESCRIPTION:

5.1 METHODS OF MEASUREMENT AND SENSOR DESCRIPTION:

- a. Methods of Measurement: Not pertinent.
- b. Sensor Description: Satellite characteristics and nominal orbit parameters of each type of satellite are listed below.

(1) COMSATS

Weight: 86 pounds

Description: Cylinder 28 inches in diameter and 15.5 inches high.

Orbit: Synchronous equatorial orbit

(2) APPLICATIONS TECHNOLOGY SATELLITES

Weight: 700 pounds (1550 pounds with apogee kick motor)

Description: Cylinder 66 inches high and 59 inches in diameter.

Orbit: 6000-mile circular orbit, 28 to 30 degree inclination

(3) TOPSIDE SOUNDERS

Weight: 97 pounds

Description: Cylinder 26 inches in diameter and 46.5 inches high.

Orbit: Period: 103.9 minutes  
Perigee: 540 miles  
Apogee: 634 miles  
Inclination: 79.9 degrees

(4) ADVANCED WEATHER SATELLITES

Weight: 305 pounds

Description: 18-sided polyhedron, 22 inches high and 42 inches in diameter.

Orbit: Sun-synchronized circular orbit, 750-n.mi. altitude, 113-minute period, and 81-degree retrograde inclination.

(5) ADVANCED ORBITING SOLAR OBSERVATORIES

Weight: 1450 pounds

Description: Cylinder 125 inches long and 48 inches in diameter. Eight solar panels with a span of 20 feet are mounted on one end of the cylinder; UHF and VHF antennas are mounted on the ends of opposing solar panels

Orbit: 82-degree retrograde orbit, 300-nautical mile altitude

(6) ORBITING GEOPHYSICAL OBSERVATORIES

Weight: 1046 pounds

Description: Aluminum main body, 67 inches long and 31 inches square. Two solar panels are mounted on the sides of the body. A 30-foot radio astronomy antenna is deployed from one solar panel. Two 22-foot and four 6-foot experiment booms are extended from the ends of the body.

Orbit: Period: 64 hours  
Perigee: 175 miles  
Apogee: 92,827 miles  
Inclination: 31.1 degrees

(7) ORBITING ASTRONOMICAL OBSERVATORIES

Weight: 3600 pounds

Description: Octagonal aluminum structure, 116 inches long and 80 inches wide, with four solar panels mounted on the sides.

Orbit: 500-mile circular orbit

(8) ADVANCED NAVIGATIONAL AND GEODETIC SATELLITES

Weight: 135 pounds

Description: Octagonal body, 12 inches high and 18 inches across, with four solar panels mounted on the sides and a self-erecting boom with damping spring and end mass extending from the top.

Orbit: Period: 99.2 minutes  
Perigee: 432 miles  
Apogee: 455 miles  
Inclination: 90.7 degrees

(9) AIR DENSITY-INJUN EXPLORERS

Weight: 109 pounds (19 pounds air density;  
90 pounds INJUN)

SDT-5  
(Sheet 7)

Description: Aluminum shell with 40 sides, 24 inches in diameter. Cylindrical tube on top contains air density inflatable balloon. Three short experiment booms extend from spacecraft.

Orbit: Period: 116.3 minutes  
Perigee: 345 miles  
Apogee: 1547 miles  
Inclination: 81.4 degrees

(10) ADVANCED NUCLEAR EVENT DETECTION SATELLITES

Weight: 319 pounds (516 pounds with apogee kick motor)

Description: Icosahedron (20 sides), 54 inches in diameter

Orbit: Period: 100.3 hours  
Perigee: 63,369 miles  
Apogee: 65,024 miles  
Inclination: 39.5 degrees

(11) ADVANCED SPECIAL-PURPOSE SATELLITES

Weight: 5000 pounds

Description: Unavailable

Orbit: Period: 90.2 minutes  
Perigee: 121 miles  
Apogee: 227 miles  
Inclination: 82.3 degrees

(12) MICROMETEOROID DETECTION SATELLITES

Weight: 295 pounds

Description: Cylinder 24 inches in diameter and 92 inches long

Orbit: Period: 99.2 minutes  
Perigee: 288 miles  
Apogee: 610 miles  
Inclination: 51.9 degrees

(13) MAGNETOSPHERE EXPLORERS

Weight: 140 pounds

Description: Octagonal platform atop a truncated cone, 27 3/4 inches across and 17 inches high. Four solar panels extend from the sides, and a 34-inch tube supporting the magnetometer is mounted on top of the spacecraft.

Orbit: Perigee: from 100 to 2000 miles  
Apogee: 185,000 miles  
Inclination: 36 degrees

(14) ENERGETIC PARTICLES EXPLORERS

Weight: 101 pounds

Description: Same basic design as Magnetosphere Explorers.

Orbit: Period: 456 minutes  
Perigee: 190 miles  
Apogee: 16,280 miles  
Inclination: 20.2 degrees

(15) BIOSATELLITES

Weight: 875 to 1250 pounds

Description: Cylindrical vehicle about 93 inches long and 44 inches in diameter. Recoverable reentry capsule forms the nose of the vehicle.

Orbit: 200-mile circular orbit; inclination; 20 to 80 degrees

5.2 DATA COLLECTION:

- a. Format: Not pertinent.
- b. Amount: Not pertinent.
- c. Recovery Advantages: Not pertinent.

- 5.3 ANCILLARY EQUIPMENT: Package design for the launch of unmanned satellites and probes will consist of (1) the definition of third-stage boosters to satisfy the orbital requirements of the individual satellites, as listed in Section 5.1.b, (2) the definition of guidance and control systems to function during third-stage boost, and (3) the definition of launch platforms and erection mechanisms on the SIVB stage. Stabilization of the SIVB stage before and during launch will be provided by the SIU equipment. Commands to erect the launch platforms and launch the satellites can be obtained on unused telemetry channels in the SIU. Electrical power required to perform the erection and launch can also be derived from the SIU.
6. CONCEPTUAL DESIGN: See Figure A.1-6.

NOTES

1. FIXED GEOMETRY PACKAGE.
2. EXPERIMENT STANDARD SHAPE  
27.8" DIA X 50.0" CYLINDER
3. ENTIRE EXPERIMENT PACKAGE TO BE  
EJECTED FROM LAUNCH VEHICLE INTO  
EARTH ORBIT.
4. TOTAL MASS LESS PROPULSION  
SYSTEM = 141 LBS.
5. PROPULSION SYS. WEIGHT = 299, LBS

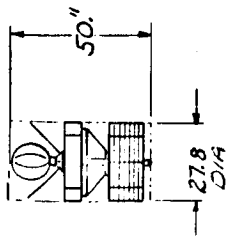

INSTALLED CONFIG.  
1/40 SIZE

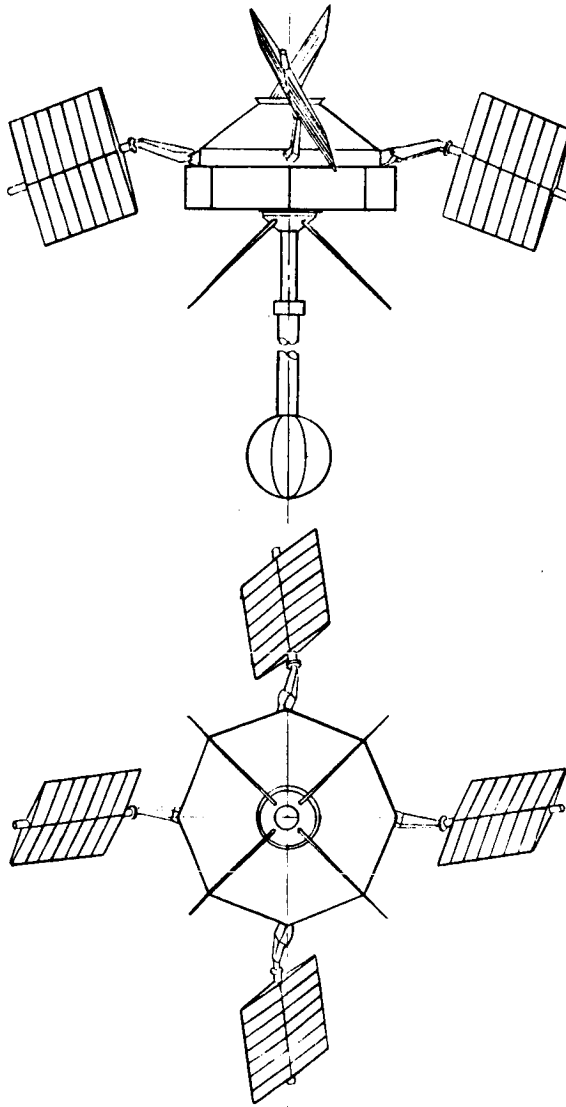

DEPLOYED CONFIGURATION  
1/15 SIZE

EXPERIMENT SDT-5  
ENERGETIC PARTICLES  
EXPLORER

SCALE NOTED // OCT 65 *Baron*

Figure A.1-6 SDT-5 CONCEPTUAL DESIGN DRAWING



CATEGORY II - MATERIALS AND STRUCTURES (MS)

The experiments in Category II provide for the evaluation of the effects of space environments on metals, plastics, and ceramics. The five experiments in this category are designated as follows:

- MS-1: Degradation of Organic Materials in a Space Environment.
- MS-2: Behavior of Liquid Films in a Space Environment.
- MS-3: Vaporization Rate of Molten Metals.
- MS-4: Cold Welding of Metals in a Space Environment.
- MS-5: Spray Coating and Surface Contamination in a Space Environment.

A conceptual design drawing for each of the 5 experiments is presented on the last page of each experiment description. In many cases, illustrations and tabular data relating to the experiment are included in the final pages of the description.

1. EXPERIMENT MS-1: Degradation of Organic Materials in Space Environment.
2. TECHNICAL AREA/APPLICATIONS:
  - 2.1 GENERAL AREA: Materials and Structures
  - 2.2 EXPERIMENT APPLICATIONS: To determine the stability of organic materials for their use in spacecraft structures. Results will serve two purposes:
    - a. To make selection of most suitable existing materials.
    - b. To obtain basic data on degradation as a basis for the development of improved compositions.
3. EXPERIMENT OBJECTIVES AND SCOPE:
  - 3.1 OBJECTIVES:
    - a. Specific Objective: To determine the combined effect of various, partly unknown, species of space radiation (far UV and high energy), space vacuum, and temperature upon organic materials.
    - b. Key Techniques: Samples of typical organic structural materials (plastics) will be exposed to space environment for a minimum period of two months and returned to earth for detailed analysis.
  - 3.2 MEASUREMENTS AND DATA:
    - a. Phenomena to be Observed: No flight observation will be made except sensing of specimen temperature in regular intervals. Measurement of total time of exposure and orbital characteristics are provided by the basic mission.
    - b. Measurement Rate, Accuracy: Temperature measurements every 10 hours for 2 hours duration with an accuracy of  $\pm 3^{\circ}$  R.
  - 3.3 FLIGHT REGIME:
    - a. Orbital Parameters: As provided by basic mission, minimum altitude 150 miles.

- b. Duration: One to three months continuous.
- c. Seasonal Requirements: None
- d. Other Flight Characteristics: Vehicle attitude control by sun sensor. Experiment located at sun-exposed side.
- e. Reasons: In the post-recovery evaluation, results will be related to total orbital conditions as provided by basic mission.

#### 3.4 SUPPORT EXPERIMENTATION:

- a. Simultaneous Activities: None
- b. Prerequisite Experimentation: Detailed laboratory analysis of sample materials before installation with regard to composition and molecular, physical, thermal, and electromagnetic properties.

#### 4. OPERATIONS:

##### 4.1 DUTY CYCLE:

- a. Operational Periods:
  - (1) Duration of each operational period: 2 hours.
  - (2) Number of periods: 120 to 240.
  - (3) For timing of individual measurements, see Figure A.2-1.
- b. Interval: 10 hours between operational periods.

##### 4.2 CREW REQUIREMENTS:

- a. Astronaut Participation:
  - (1) None, if experiment can be located in a recovery section together with other recoverable experiments.
  - (2) Recovery of specimen package and tape by astronaut, if automatic recovery is not available.
- b. Crew Involvement: None

5. APPARATUS DESCRIPTION:

5.1 METHODS OF MEASUREMENT AND SENSOR DESCRIPTION:

a. Methods of Measurement:

- (1) Deployment of sample package by automatic signal upon attaining orbit.
- (2) Intermittent measuring and in-package recording of sample temperatures, using thermocouples and tape recorder.
- (3) Retraction of sample package after 2-4 months.
- (4) Return to ground and recovery.
- (5) Laboratory evaluation.

b. Sensor Description:

- (1) Sensor A (Figure A.2-2) MS-1 Temperature Recorder.
- (2) Sensor B (Figure A.2-2) MS-1 Sun Sensor

5.2 DATA COLLECTION:

- a. Format: Temperature measurement stored on tape, which is recovered together with sample package.
- b. Amount: One tape containing 2880 (min) to 5760 (max) measuring cycles of 28,800 (min) to 57,600 (max) individual data.
- c. Recovery Advantages: As experiment postulates sample package recovery, recording tape is returned in same package in lieu of telemetering.

5.3 ANCILLARY EQUIPMENT: See Figures A.2-1 and A.2-2.

SENSOR A

1. Equipment Name: MS-1 Temperature Recorder Unit
2. Equipment Size Stored (lxwxh): Approximately 8 x 4 x 2 inches
3. Equipment Size Operating (lxwxh): Same
4. Equipment Weight: Approximately 4 pounds

(SENSOR A Continued)

5. Power Requirements (peaks and duty cycles): 50 watts in 40-sec periods intermittent over 2 hours. Accumulated requirements over 4-month period = 3.2 kwh.
6. Environmental Considerations (heat output, limiting temperatures, pressurization vibration, etc.): Recovery package not to exceed 100°F during recovery.
7. Frequency Spectrum: Not applicable.
8. Accuracy Considerations:  $\pm 3^{\circ}$  R recorded temperature.
9. Pointing Accuracy Considerations: Not applicable.
10. Development Status: Standard components and techniques.
11. Reliability: Must function for 4 months (58,000 readings).

SENSOR B

1. Equipment Name: Sun Sensor
2. Equipment Size Stored (lxwxh): Included in apparatus package description.
3. Equipment Size Operating (lxwxh): Not applicable.
4. Equipment Weight: Approximately 2 pounds.
5. Power Requirements (peaks and duty cycles): 10 watts continuous for each period (maximum accumulated time = 480 hours).
6. Environmental Considerations (heat output, limiting temperatures, pressurization vibration, etc.): None
7. Frequency Spectrum: Not applicable.
8. Accuracy Considerations: Moderate, since only used for on-off control.
9. Pointing Accuracy Considerations: Covering hemisphere over vehicle surface as base.
10. Development Status: Available
11. Reliability: Maximum Operation time = 4 months

APPARATUS DESCRIPTION

- APPARATUS: MS-1 Apparatus Package (to be recovered).
- FUNCTION: Stores, deploys and retracts 16 material samples. Records sample temperatures on tape. Complete package is recovered.
- COMPONENTS:
1. Apparatus container
  2. Cover plate
  3. MS-1 sample package
    - a. Holder
    - b. Samples
    - c. Thermocouples
  4. Deployment and Retraction System
    - a. Mechanism
    - b. Command actuator
  5. Temperature recorder (Sensor A)
  6. Sun sensor (Sensor B)
- DESIGN: See Figure A.2-3
- LOCATION: At the surface of the recovery section, together with other recoverable experiments. (It is assumed that, at least, part of the basic missions include such recovery.) Preferred location: Area 1 - LEM adapter.
- DIMENSIONS: 30 x 16-inch surface area x 12-inch depth.
- WEIGHT: 28 pounds, excluding reentry heat protection and power supply.
- POWER REQTS: Approximately 200 watts intermittent over 4 months max. Total accumulated requirement: 4.2 kwh, net. See Tables A.2-1 and A.2-2.
6. CONCEPTUAL DESIGN: See Figure A.2-4

TABLE A.2-1

MEASURING/AMOUNT (MS-1)

Each Cycle:	10 measurements, 4 sec each	= 40 sec
Each Period:	24 cycles, 40 sec each	= 960 sec = 16 min
2-Month Operation:	120 periods	= 1920 min = 32 hr
4-Month Operation (max time):		= 64 hr

TABLE A.2-2

POWER REQUIREMENTS (MS-1)

Measuring: 50 watts		
2 months operation:	0.05 x 32	= 1.6 kwh
4 months operation:	0.05 x 64	= 3.2 kwh
Deployment: 150 watts (incl. Sun Sensor)		
1 deployment cycle		= 20 sec
Each period: 3 cycles		= 1 min
2-month period = 120 periods		= 120 min = 0.3 kwh
4-month period		= 0.6 kwh
Total Maximum		= 3.8 kwh
+ 10% for losses		= 4.2 kwh

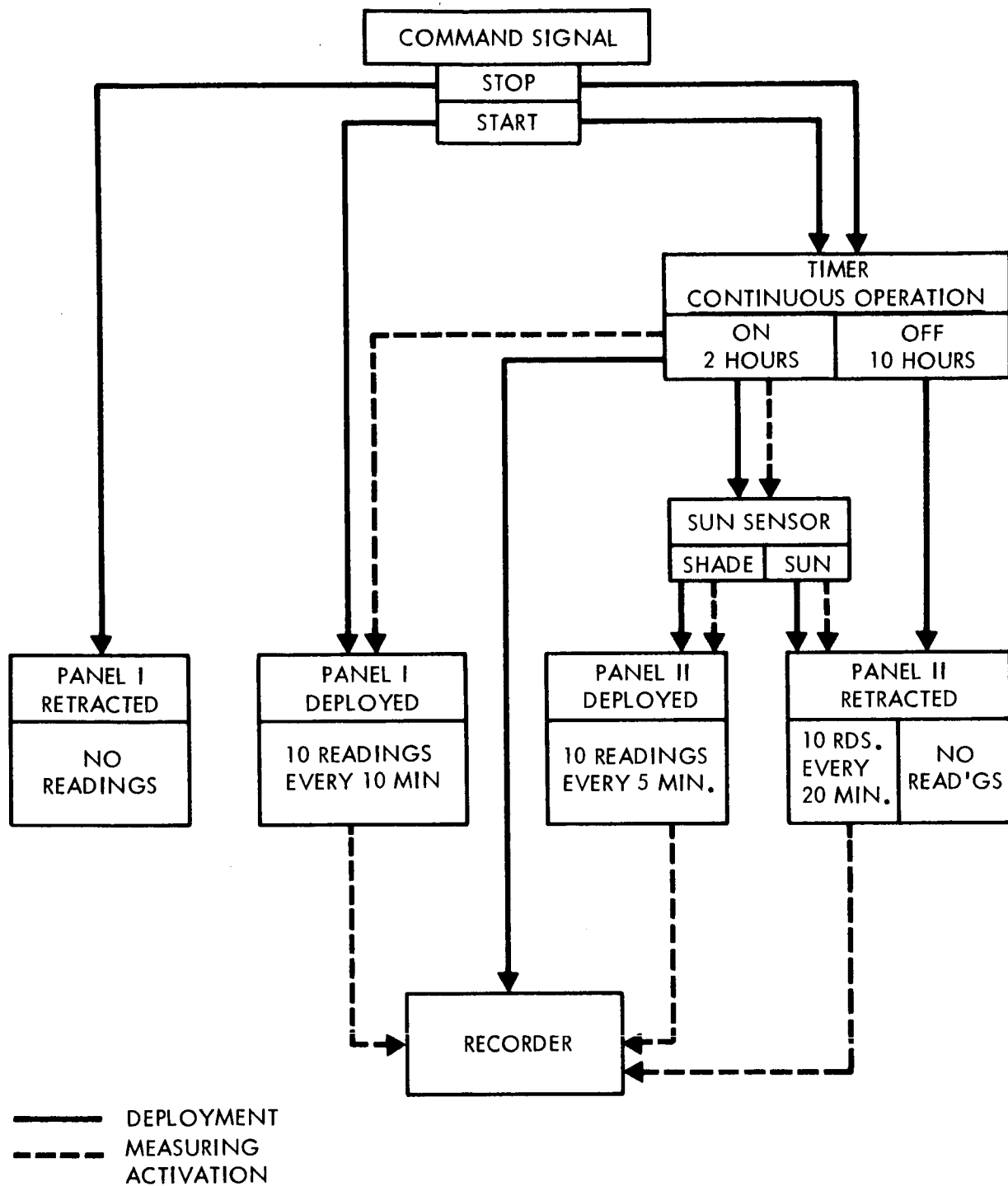

Figure A. 2-1 MS-1 TIMING SYSTEM



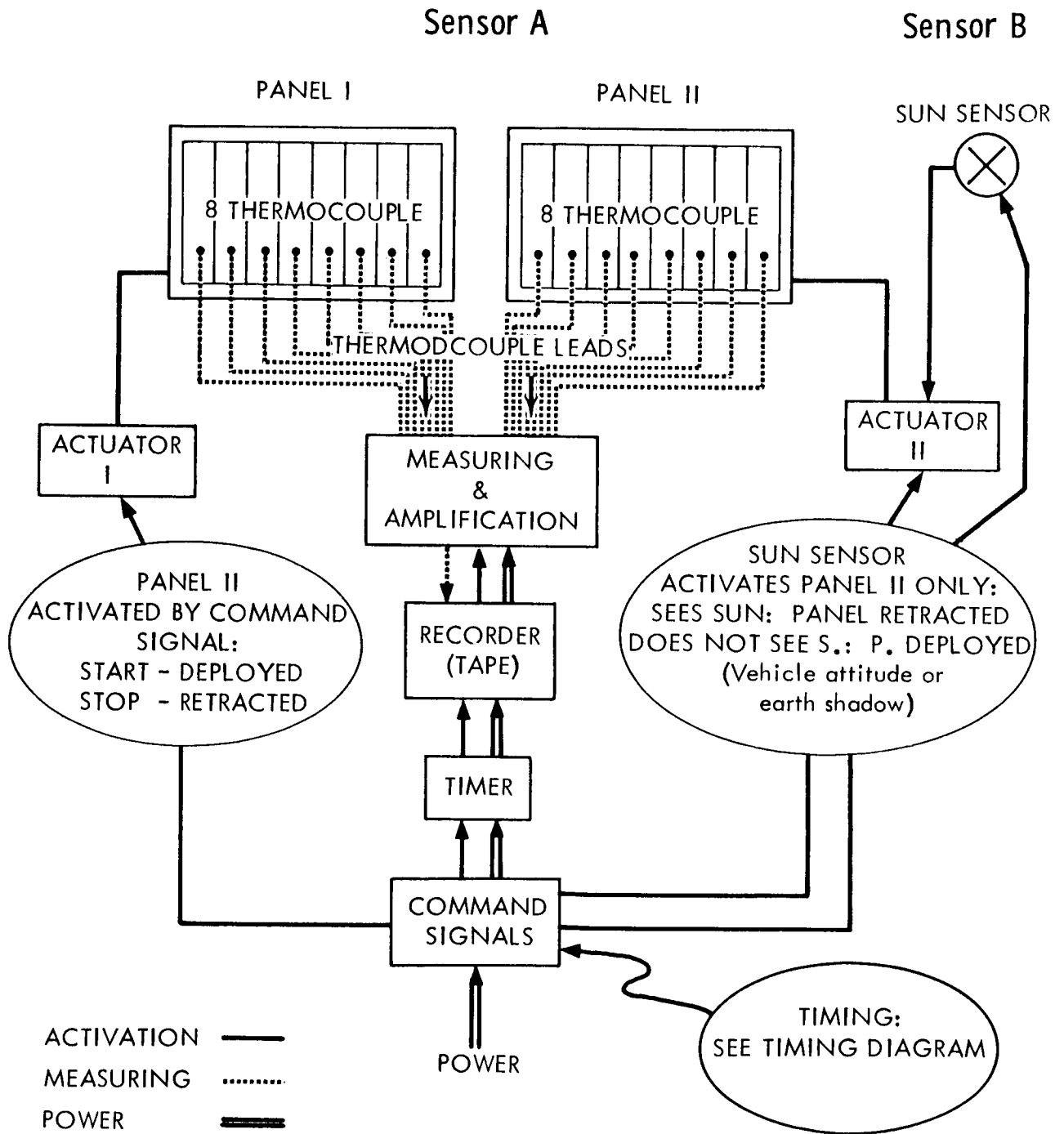
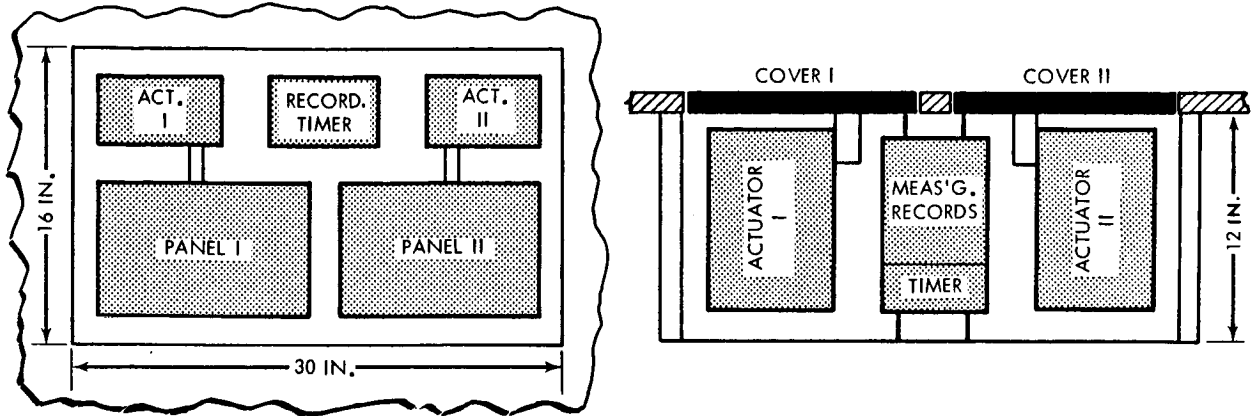
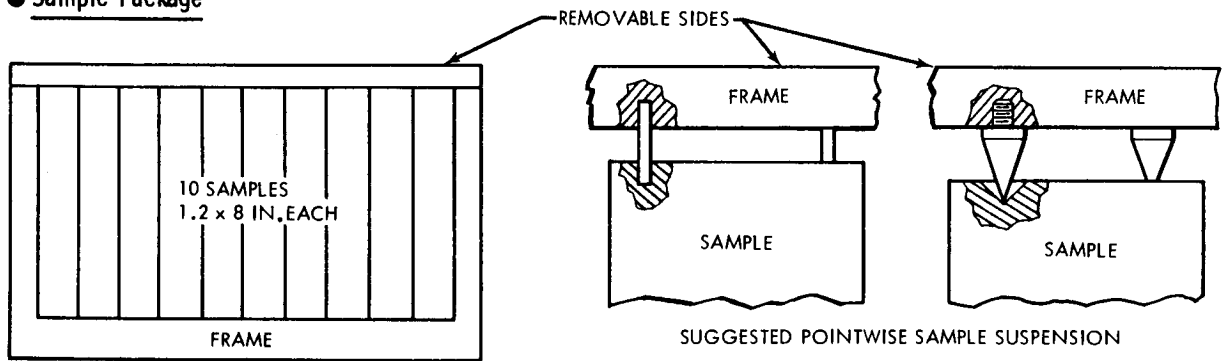

Figure A.2-2 MS-1 SENSOR SYSTEM: TEMPERATURE RECORDING

● Component Identification & Assembly



● Sample Package



● Deployment Schemes

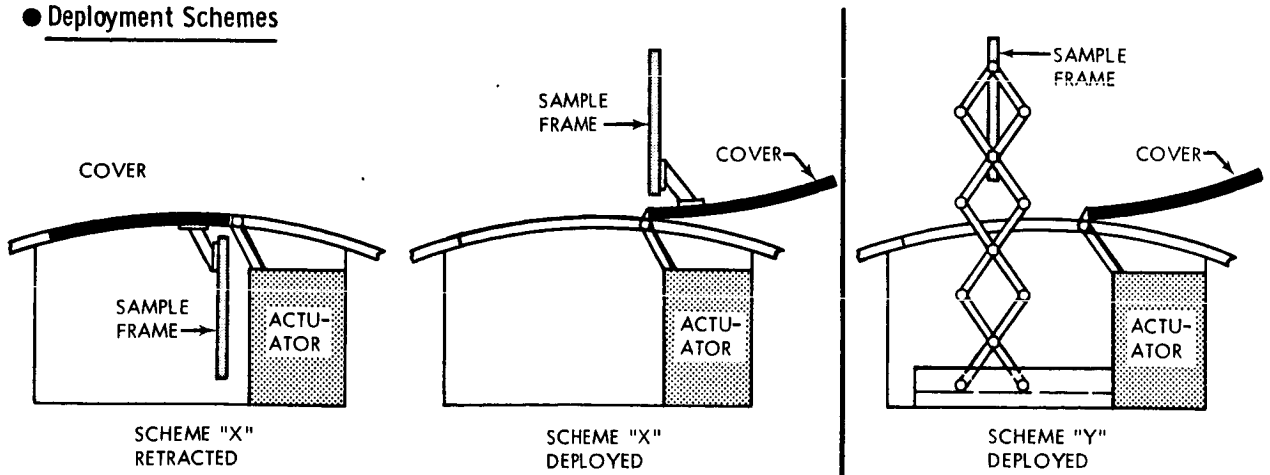
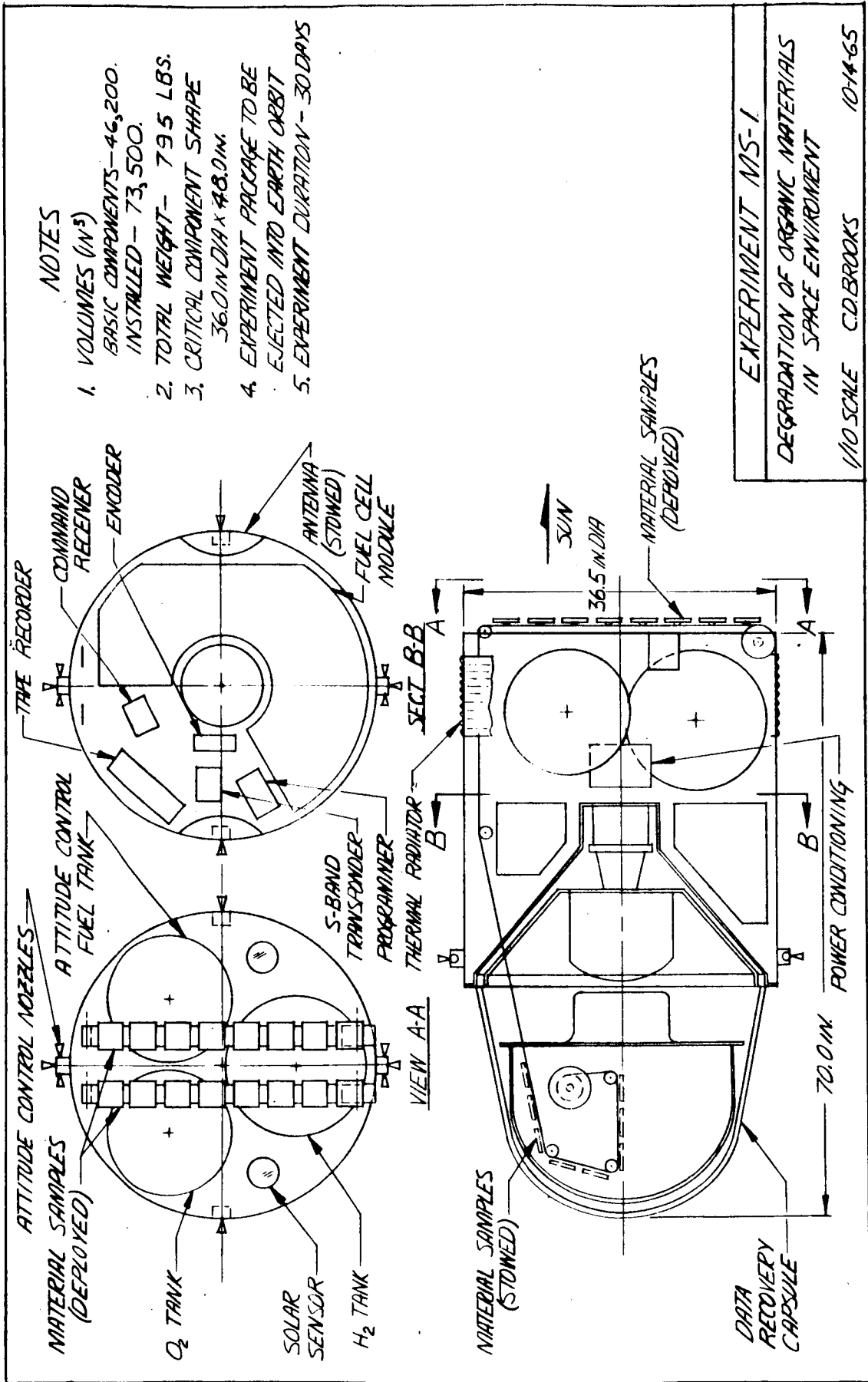

Figure A. 2-3 MS-1 EXPERIMENT PACKAGE



**NOTES**

1. VOLUMES (IN<sup>3</sup>)  
 BASIC COMPONENTS - 46,200.  
 INSTALLED - 73,500.
2. TOTAL WEIGHT - 795 LBS.
3. CRITICAL COMPONENT SHAPE  
 36.0 IN DIA x 48.0 IN.
4. EXPERIMENT PACKAGE TO BE  
 EJECTED INTO EARTH ORBIT
5. EXPERIMENT DURATION - 30 DAYS

**EXPERIMENT MS-1**  
 DEGRADATION OF ORGANIC MATERIALS  
 IN SPACE ENVIRONMENT  
 1/10 SCALE CD. BROOKS 10-14-65

Figure A.2-4 MS-1 CONCEPTUAL DESIGN DRAWING

1. EXPERIMENT MS-2: Behavior of Liquid Films in Space Environment

2. TECHNICAL AREA/APPLICATIONS:

2.1 GENERAL AREA: Materials and Structures

2.2 EXPERIMENT APPLICATIONS: To develop welding, coating, and cleaning techniques for orbital assembly and repair. The behavior of liquid films may also be of general interest for advanced applications and for physical sciences.

3. EXPERIMENT OBJECTIVES AND SCOPE:

3.1 OBJECTIVES:

- a. Specific Objective: To investigate the stability and potential coagulation of liquid metal films, under the effect of hard vacuum and weightlessness, upon the interplay between surface tension and adhesion.
- b. Key Techniques: Nine ceramic discs  $7\frac{1}{2}$  inches in diameter and  $1\frac{1}{2}$  inches high are inserted in a payload surface panel. Each outer disc surface has a cone-shape indentation, coated with a metallic film.

After reaching orbit, metal coatings are melted by means of a built-in heat element. Film behavior is measured with several (8) electric contacts in the ceramic cone surface. Coagulation is detected by opening of contacts as the conductive metal film recedes toward the cone tip.

3.2 MEASUREMENTS AND DATA:

- a. Phenomena to be Observed: Movement of liquid film, such as potential coagulation and rate of coagulation, observed by means of contact signals transmitted to ground station by telemetry.
- b. Measurement Rate, Accuracy: Simple on-off signals at intervals in terms of seconds or minutes. Eight distinguishable signals in each test, indicating position of sensor contact.

3.3 FLIGHT REGIME:

- a. Orbital Parameters: Experiment operation during apogee periods only. Timing selected by command signals from ground.

- b. Duration: Experiment requires 18 orbits maximum.
- c. Seasonal Requirements: None
- d. Other Flight Characteristics: Desired minimum apogee altitude 150 miles.
- e. Reason for Item d: Vacuum  $10^{-7}$  minimum Hg (min) required.

3.4 SUPPORT EXPERIMENTATION:

- a. Simultaneous Activities: None
- b. Prerequisite Experimentation: None, except usual ground simulation and checkout.

4. OPERATIONS:

4.1 DUTY CYCLE:

- a. Operational Periods: Total of 18 tests periods (max) of 10 minutes duration each during apogee periods. One or two test periods per apogee period. Total operation (and telemetry recorders) time 3 hours in 18 ten-minute periods.
- b. Interval:
  - (1) Orbit intervals between apogee periods.
  - (2) Time dependent upon orbital characteristics.See also the attached "Sequence of Operations."

4.2 CREW REQUIREMENTS:

- a. Astronaut Participation: As specified, experiment does not require astronaut participation. However, if flight is manned, all telemetry and ground observation may be replaced by on-board operations (command signals, observation and recording of sensor signals).
- b. Crew Involvement: None

5. APPARATUS DESCRIPTION:

5.1 METHODS OF MEASUREMENT AND SENSOR DESCRIPTION:

a. Methods of Measurement:

(1) Test Data: 8 contacts located in each sensor surface are initially closed by metal film. Measurement of film movement is detected and observed by opening of contacts (identifiable), transmitted to ground station by telemetry. (If manned, observation and recording by astronaut.)

(2) Temperature controls by thermostat, automatic.

b. Sensor Description: Sensor A (see attached description).

5.2 DATA COLLECTION:

a. Format: Single signals on ground recorder.

b. Amount:

(1) Maximum: 8 signals per test period (10 min), total of 144 signals during 18 (max) apogee periods.

(2) Maximum total recording time: 3 hours.

c. Recovery Advantages: No recovery required, as specified. However, if basic mission provides for recovery of experiment section, valuable additional evaluations of experiment (sensors) can be made.

5.3 ANCILLARY EQUIPMENT: Power supply or battery for 0.6 kwh.

SENSOR A

1. Equipment Name: Liquid Film Sensor
2. Equipment Size Stored (lxwxh): 12 x 12 (surface) x 5 inches, excluding power supply
3. Equipment Size Operating (lxwxh): Same as Item 2.
4. Equipment Weight: Approximately 12 pounds.
5. Power Requirements (peaks and duty cycles): 200 watts for total of 3 hours in 10-minute periods, total of 0.6 kwh.

(SENSOR A Continued)

6. Environmental Considerations (heat output, limiting temperatures, pressurization vibration, etc.):
  - a. Vehicle attitude control: spinning not acceptable.
  - b. Heat flow to vehicle: 2 Btu/min = 20 Btu/period (max).
7. Frequency Spectrum: Not applicable
8. Accuracy Considerations: Not applicable
9. Pointing Accuracy Considerations: None
10. Development Status: Experiment not developed, and as yet does not present any problems.
11. Reliability: Extremely high, because of deliberate simplicity of technique and data transmission.

### APPARATUS DESCRIPTION

APPARATUS: MS-2 Experiment Package

FUNCTION: Melts metal coating on 9 specimens, to produce liquid film. Measures physical behavior (movement) of film.

COMPONENTS:

1. Apparatus container (no cover)
2. Sample Package
  - a. Holder plate
  - b. Ceramic blocks with heating element, measuring contacts, and lead wires
  - c. Metallic coating
3. Insulation
4. Switch unit
5. Switch and insulation support

DESIGN: See Figures A.2-5 and A.2-6

LOCATION: At vehicle surface, anywhere.

DIMENSIONS: 12 x 12-inch surface x 5-inch depth

WEIGHT: Approximately 12 pounds, excluding power supply or battery and telemetry support.

POWER REQMTS: 200 watts for 10-minute (max) periods, total of 0.6 kwh.

SEQUENCE OF OPERATIONS

1. Command Signal 1 (Figure A.2-5): Time switch proceeds to Position 1.
  - a. Heating and telemetry of Sensor A-1 operating
  - b. Temperature controlled by preset thermostat
  - c. After melting of metal coating, movement of liquid film is indicated by opening of Contact 1 to 8.
  - d. After 10 minutes operation, time switch proceeds to next (0) position and awaits new command signal.
2. Command Signal 2: Time switch proceeds to Position 2 etc., as above.

Number of tests in each apogee period depends on orbital characteristics. If no new signal is given, time switch moves after 10 minutes operation to next zero position, disconnecting all lines, and awaits new signal.

After completion of one round (9 tests), behavior of remaining metal film may be observed in a second round, repeating above sequence of operations. Power supply of 0.6 kwh is based on two rounds.

6. CONCEPTUAL DESIGN: See Figure A.2-6.



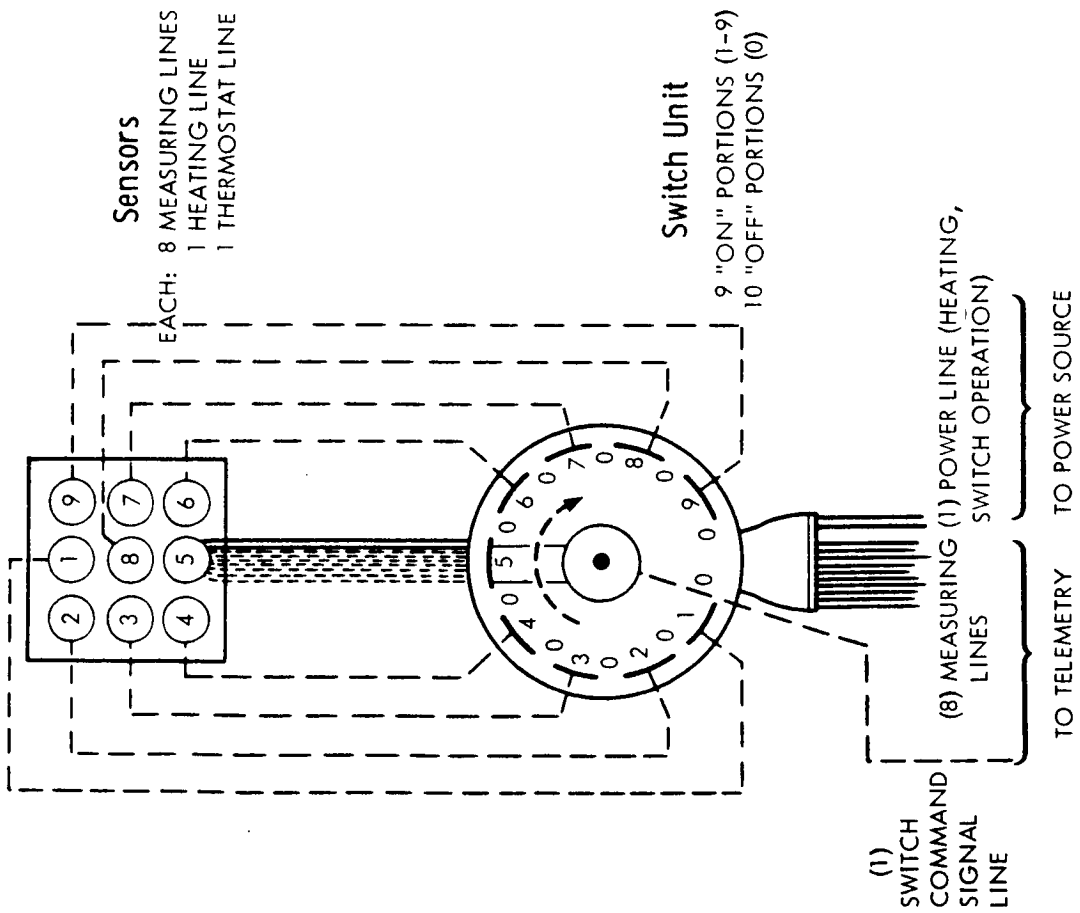

Assembly

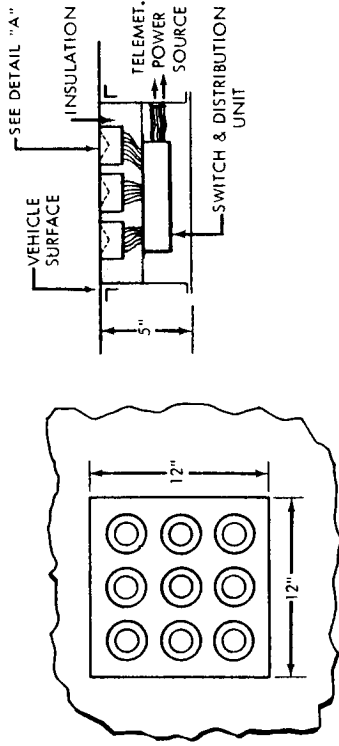

Detail "A": Sensor A

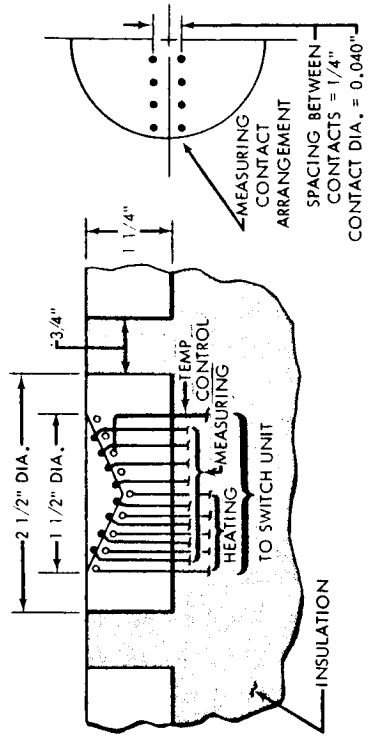

WIRING DIAGRAM

APPARATUS

Figure A. 2-5 MS-2 WIRING DIAGRAM AND APPARATUS

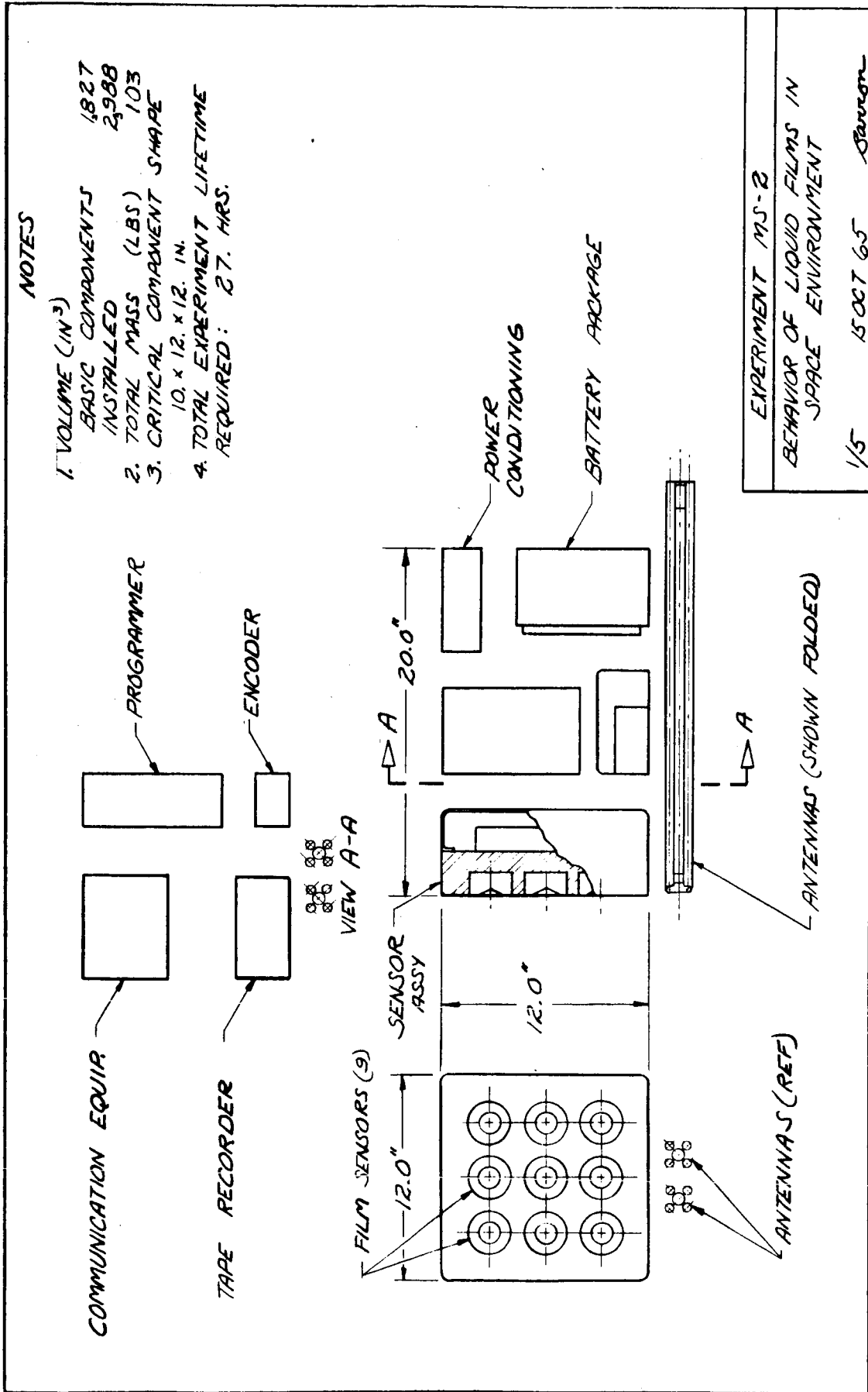

Figure A. 2-6 MS-2 CONCEPTUAL DESIGN DRAWING

1. EXPERIMENT MS-3: Vaporization Rate of Molten Metals
2. TECHNICAL AREA/APPLICATIONS:
  - 2.1 GENERAL AREA: Materials and Structures
  - 2.2 EXPERIMENT APPLICATIONS: To produce reliable data on the vaporization rates of molten metals, for the feasibility of fusion welding and brazing in orbital repair and assembly.
3. OBJECTIVES AND SCOPE:
  - 3.1 OBJECTIVES:
    - a. Specific Objective: To determine the vaporization rate of molten metals at the ambient pressures of lower orbits ( $10^{-6}$  to  $10^{-8}$  mm Hg).
    - b. Key Techniques: A ceramic insert for the payload surface of approximately 2-inch-diameter contains test metal in a 3/4-inch-diameter conical receptacle connected with the environment by a 1/2-inch hole. Metal is melted after reaching orbit by heating element embedded in the ceramic material. Vaporization is measured by interruption of electrical contacts in receptacle wall. The experiment calls for 9 inserts containing pure metals with varying ratios of melting and boiling (sublimation) temperatures, as well as three typical alloys for space structures.
  - 3.2 MEASUREMENTS AND DATA:
    - a. Phenomena to be Observed:
      - (1) Temperature of test metal.
      - (2) Vaporization of test metal: Depletion of receptacle detected by the opening of electrical contacts in the metal-covered surface.
    - b. Measurement Rate, Accuracy:
      - (1) Temperature: Continuous over test period ( $\pm 10^{\circ}\text{F}$ )

- (2) Metal depletion: Continuous observation over test period, yet only 10 signals (maximum) per test period.
- (3) Total number of measuring points: 81 (maximum)

### 3.3 FLIGHT REGIME:

#### a. Orbital Parameters

- (1) Vehicle attitude control: Spinning not acceptable.
- (2) Circular (or close to circular) orbit desired.\*

b. Duration: Test periods vary between 20 minutes and 4 hours. Total time, approximate periods: 26 hours.

c. Seasonal Requirements: None

d. Other Flight Characteristics: Short period tests are carried out during apogee position, to obtain highest vacuum.

e. Reasons: Regarding Item A(2), too much deviation from circular orbit reduces value of experiment (correlation with pressure).

### 3.4 SUPPORT EXPERIMENTATION:

a. Simultaneous Activities: None

b. Prerequisite Experimentation: None, except ground calibration and checkout.

---

\*Value of 2/3 of the tests decreases with increasing apogee/perigee ratio, because of wider variation of ambient pressure.

4. OPERATIONS:

4.1 DUTY CYCLE:

a. Operational Periods:

2 periods of 4 hours duration

6 periods of 2 hours duration

4 periods of 1 hour duration

6 periods of 20 minutes duration

Timing (start) should provide maximum time at high altitude. Short tests at apogee.

b. Interval: Intervals immaterial; interval time depends on timing (above) and orbital characteristics.

4.2 CREW REQUIREMENTS:

a. Astronaut Participation: Experiment as specified does not require astronaut participation. In manned flights, however, command signal and data recording can be carried out on board, replacing telemetry.

b. Crew Involvements: None.

5. APPARATUS DESCRIPTION:

5.1 METHODS OF MEASUREMENT AND SENSOR DESCRIPTION:

a. Methods of Measurement:

(1) Temperature by thermocouple and telemetry; continuous during each period.

(2) Metal depletion: Opening of electrical contacts located in receptacle, effected by receding metal. Location of contacts identified by different resistance. Telemetry to ground.

b. Sensor Description: Sensor A, described on following pages.

5.2 DATA COLLECTION:

a. Format:

- (1) Temperature: Temperature/time curve, continuous.
- (2) Vaporization rate: Individual signals of different magnitude (resistance) versus time.

b. Amount:

- (1) Temperature: Total of 26 hours sensing and transmission
- (2) Vaporization rate: Maximum of 81 individual signals, total.

c. Recovery Advantages: None

5.3 ANCILLARY EQUIPMENT:

a. Central power supply or battery for 3.0 kwh.

b. Telemetry

SENSOR A

1. Equipment Name: Molten Metal Vaporization Sensor.
2. Equipment Size Stored (lxwxh): 11 x 11-inch (surface) x 5-inch deep.
3. Equipment Size Operating (lxwxh): Same.
4. Equipment Weight: Approximately 10 pounds.
5. Power Requirements (peaks and duty cycles): Peaks: 250 watts; duty: 100 watts; total: 3.0 kwh..
6. Environmental Consideration:(heat output, limiting temperatures, pressurization, vibration, etc.)
  - (a) Vehicle attitude control: Spinning not acceptable.
  - (b) Heat flow to vehicle = 2 Btu/min.

- 7. Frequency Spectrum: N/A
- 8. Accuracy Considerations: N/A
- 9. Pointing Accuracy Considerations: None.
- 10. Development Status: Experiment not developed, yet does not present any problems.
- 11. Reliability: Extremely high, because of deliberate simplicity of technique and data transmission.

APPARATUS DESCRIPTION

APPARATUS: MS-3 experiment package

FUNCTIONS: Melts 9 metal samples and measures their dissipation by vaporization.

COMPONENTS:

- 1. Apparatus container (no cover)
- 2. Sample holder plate
- 3. Sample Assembly
  - a. Ceramic body
  - b. Sensing contacts with lead wires
  - c. Thermocouple with lead wires
  - d. Heating element with lead wires
  - e. Test metal
- 4. Insulation
- 5. Switch unit
- 6. Insulation and switch support

DESIGN: See Figure A.2-7 and A.2-8.

LOCATION: At vehicle surface, anywhere.

WEIGHT: Approximately 11 pounds.

POWER REQMTS: 250 watts maximum, total 3.0 kwh

TIMER AND WIRING: See Figure A.2-7. Timer carries out 2 revolutions.

SEQUENCE OF OPERATIONS

As soon as orbital characteristics of basic mission have been determined, a complete experiment schedule is established, which provides optimum conditions (starting time) for each test period.

1. In accordance with experiment schedule, start signal moves by ground command, move switch to Position 1, activating heating, measuring and temperature control circuits.
2. Observations:
  - (a) Temperature: continuous
  - (b) Sensing contact signals
  - (c) Relation to altitude from basic mission tracking
3. Regardless of whether experiment is finished or not, timer moves to next (0) position after preset time for Period 1. Duration of periods, see below.
4. Timer awaits new start signal to move to Position 2, activating Period 2.

Continuation through all 18 periods, repeating sequence 1-4, above.

Table A.2-3

Duration of Test Periods

<u>Periods</u>	<u>Minutes</u>
1, 10	20
2, 11	120
3, 12	120
4, 13	20
5, 14	60
6, 15	60
7, 16	20
8, 17	120
9, 18	240

6. CONCEPTUAL DESIGN: See Figure A.2-8.



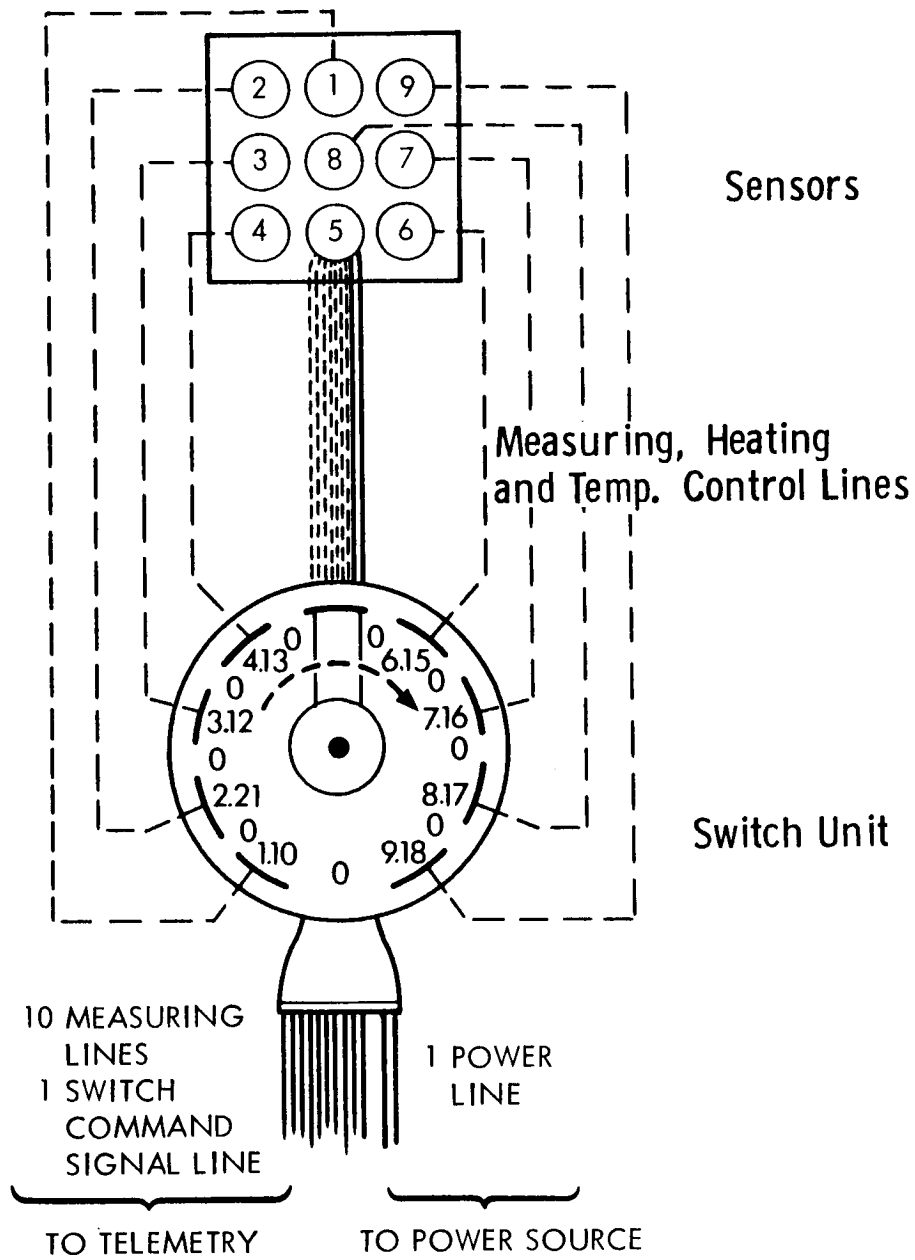

Sensors

Measuring, Heating and Temp. Control Lines

Switch Unit

Figure A. 2-7 MS-3 SWITCH UNIT AND WIRING

- NOTES -

1. VOLUMES:  
 BASIC COMPONENTS INSTALLED  
 2,809 IN<sup>3</sup>  
 3,750 IN<sup>3</sup>  
 154 LBS.  
 26 HRS
2. TOTAL MASS
3. EXPERIMENT DURATION
4. PACKAGE NOT EJECTED
5. STABILIZATION UNNECESSARY BUT TUMBLING RATE, IF ANY, MUST BE VERY LOW
6. EXPERIMENT SENSORS REQUIRE EXPOSURE TO SPACE ENVIRONMENT DURING OPERATION
7. CRITICAL COMPONENT SHAPE ~3"X10"X14"
8. ACTUAL ANTENNA LOCATIONS TO BE DETERMINED ON THE BASIS OF MECHANICAL DEPLOYMENT AND LINE-OF-SIGHT ORIENTATION REQUIREMENTS

TAPE RECORDER

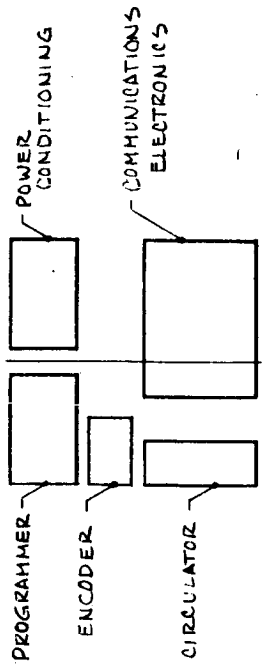
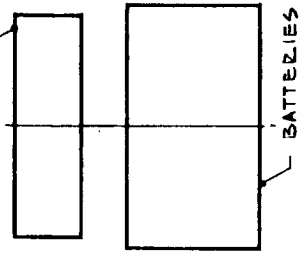

SECTION B-B

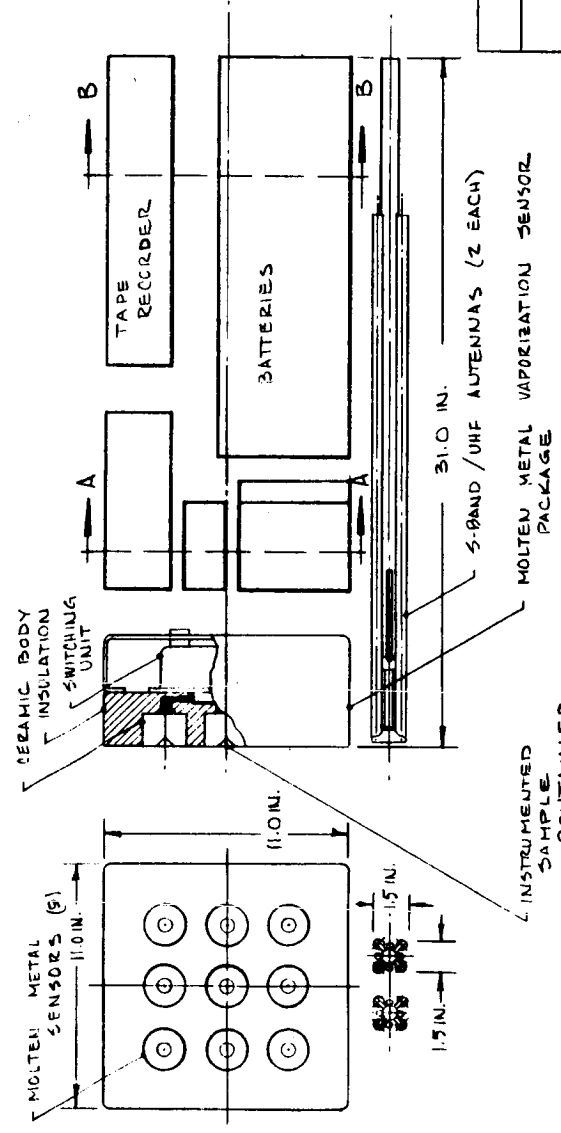

EXPERIMENT	MS-3
VAPORIZATION RATE OF MOLTEN METALS	
1/7 SCALE	G.F. GIBSON 10-15-65

Figure A. 2-8 MS-3 CONCEPTUAL DESIGN DRAWING

1. EXPERIMENT MS-4: Cold Welding of Metals in Space Environment

2. TECHNICAL AREA/APPLICATIONS:

2.1 GENERAL AREA: Materials and Structures

2.2 EXPERIMENT APPLICATIONS: To investigate the feasibility of utilizing the diffusion boundary between outgassed metal surfaces for producing welding joints in space without application of heat and moderate application of contact pressure.

3. EXPERIMENT OBJECTIVES AND SCOPE:

3.1 OBJECTIVES:

- a. Specific Objective: To produce static and sliding contact between clean metal surfaces at various contact pressures and contact times, and to measure the obtained bond strength.
- b. Key Technique: Pairs of metallic sample surfaces are brought on contact at contact pressures from 1-50 psi and times from 1-100-200 seconds, and pulled apart gradually, measuring required force for separation. Apparatus consists of two test assemblies (sensors) for static and sliding contact, which are operated concurrently for 5 duty cycles with 5 apogee periods (lowest ambient pressure).

3.2 MEASUREMENTS AND DATA:

- a. Phenomena to be Observed: Force required for separation of samples:
  - (1) by measuring time-power input characteristic of pulling magnet (Magnet d)
  - (2) by measuring time-output characteristic of a pair of strain gages.

b. Measurement Rate, Accuracy:

- (1) 5 duty cycles
- (2) Each duty cycle = two sets of measurements, recorded separately and concurrently:

Sensor A: 8 periods of 2 min = 16 min, total 80 min.

Sensor B: 6 periods of 2 min = 12 min, total 60 min.

(3) Accuracy  $\pm$  3% of full range.

### 3.3 FLIGHT REGIME:

- a. Orbital Parameters: To obtain lowest pressure environment, duty cycles are programmed at apogee periods ( 5 orbits).
- b. Duration: Each of 5 duty cycles from 12 minutes before to 12 minutes after apogee position; 24 minutes each cycle.
- c. Seasonal Requirements: None
- d. Other Flight Characteristics: None
- e. Reasons: Not applicable

### 3.4 SUPPORT EXPERIMENTATION:

- a. Simultaneous Activities: Not applicable
- b. Prerequisite Experimentation: Development and check-out tests in ground vacuum chamber capable of 10<sup>-8</sup> mm Hg.

## 4. OPERATIONS:

### 4.1 DUTY CYCLE:

- a. Operational Periods:
  - (1) 5 duty cycles of 24 minutes duration during 5 consecutive apogee periods.
  - (2) Further breakdown of duty cycles in test periods and tests shown on attached pages.
- b. Interval: 5 intervals from 12 minutes past apogee to 12 minutes before next apogee.

### 4.2 CREW REQUIREMENTS:

- a. Astronaut Participation: None
- b. Crew Involvement: None

5. APPARATUS DESCRIPTION:

5.1 METHODS OF MEASUREMENT AND SENSOR DESCRIPTION:

- a. Methods of Measurement: To be recorded on tape, with time marks, and played back by telemetry: 4 strain gage outputs (2 each sensor); 2 magnet current inputs (1 each sensor); and 1 electric motor power input (Sensor B) each for a maximum duration of 80 minutes (16 minutes each duty cycle).
- b. Sensor Description:
  - (1) Sensor A: See attached pages.
  - (2) Sensor B: See attached pages.

5.2 DATA COLLECTION:

- a. Format: Tape recordings for playback to ground station.
- b. Amount: 7 separate measurements (5.1a) for 5 x 24 minutes (5 orbits) including intervals, or 5 x 16 minutes active time.
- c. Recovery Advantages: None

5.3 ANCILLARY EQUIPMENT: Telemetry channels for playback. Power supply (1.1 kw level for 2 hours) total of 2.2 kwh. (See attached "Complete Experiment Data.")

SENSOR A

1. Equipment Name: Static Contact Weld Tester
2. Equipment Size Stored (lxwxh): 14 x 8-1/2 x 5 inches.
3. Equipment Size Operating (lxwxh): Same as above
4. Equipment Weight: Approximately 15.5 pounds
5. Power Requirements (peaks and duty cycles): 300 watts for 2 hours; total 0.6 kwh.
6. Environmental Considerations (heat output, limiting temperatures, pressurization vibration, etc.): No excessive vibrations.

(SENSOR A Continued)

7. Frequency Spectrum: Not applicable
8. Accuracy Considerations: Not applicable
9. Pointing Accuracy Considerations: Not applicable
10. Development Status: Apparatus and instrumentation within state of art.
11. Reliability: High because of deliberate simplicity at the expense of sophistication. See also "Reliability Provisions"

Design and Operation - Complete sensor consists of 5 test-sub-assemblies. On each, 2 material samples a and b, are brought in contact by arm c and activation of magnet d. Contact pressure is controlled by magnet current. After a preset period magnet d is switch off, magnet e activated exerting increasing pull between samples, until weld connection (if any) is broken. Both magnet forces are measured by (a) power input (b) strain gages on arm c.

The five test assemblies are operated successively during 5 successive apogee duty cycles.

Timing of Test Periods: Five test periods with increasing pressure levels ( $p_1$ ;  $p_2$  etc.). Program of each period, controlled by central switch unit, as follows:

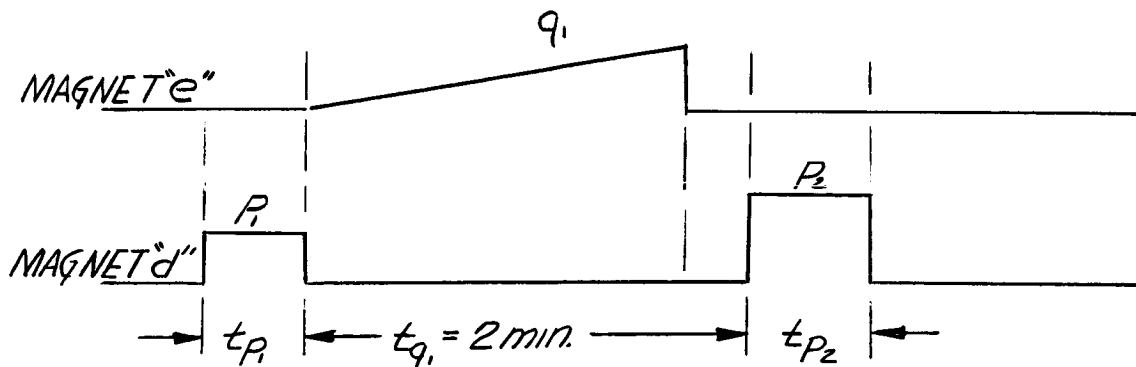

Test Schedule - Variation of contact pressure,  $p$ , contact time,  $t_p$ , and pulling time,  $t_g$ , for each duty cycle (test station) are as follows:

## (SENSOR A Continued)

<u>Test</u>	<u>p(psi)</u>	<u>tp(sec)</u>	<u>tg(sec)</u>
1	1	10	120
2	1	100	120
3	3	10	120
4	3	100	120
5	10	10	120
6	10	100	120
7	50	10	120
8	50	140	120

Total times (sec)      480              960

Total cycle 1440 seconds = 24 minutes

SENSOR B

1. Equipment Name: Sliding Contact Weld Tester
2. Equipment Size Stored (lxwxh): 14 x 8-1/2 x 5 inches
3. Equipment Size Operating (lxwxh): Same as above
4. Equipment Weight: 25.5 pounds
5. Power Requirements (peaks and duty cycles): 450 watts for 2 hours = 0.9 kwh.
6. Environmental Considerations (heat output, limiting temperatures, pressurization vibration, etc.): No excessive vibrations.
7. Frequency Spectrum: Not applicable
8. Accuracy Considerations: Not applicable
9. Pointing Accuracy Considerations: Not applicable
10. Development Status: Apparatus and instrumentation within state of art.
11. Reliability: High because of deliberate simplicity at the expense of sophistication. See also "Reliability Provision."

Design and Operation - Complete sensor consists of 5 test sub-assemblies. On each, a materials sample a is brought in contact with a rotating disc-shaped sample b by means of arm c and magnet d. Contact pressure is controlled by magnet current. Disc is

(SENSOR B Continued)

by main shaft f via electrically operated clutch. Motor remains in operation throughout entire experiment.

After a preset time, central time switch unit disengages clutch and magnet d, and, after a small waiting period, activates magnet c, exerting increasing pull on sample a, until weld connection, if any, is broken. Increasing contact welding, i.e., friction, is measured by motor power input. Pulling force is measured by magnet e current and strain gages on arm c.

If complete welding (seizing) between samples occurs before end of rotating time, clutch circuit is interrupted immediately.

The five test stations are operated successively during 5 successive apogee duty cycles.

Timing of Test Periods - Five test periods with increasing pressure levels. Program of each period, controlled by central switch unit, as follows:

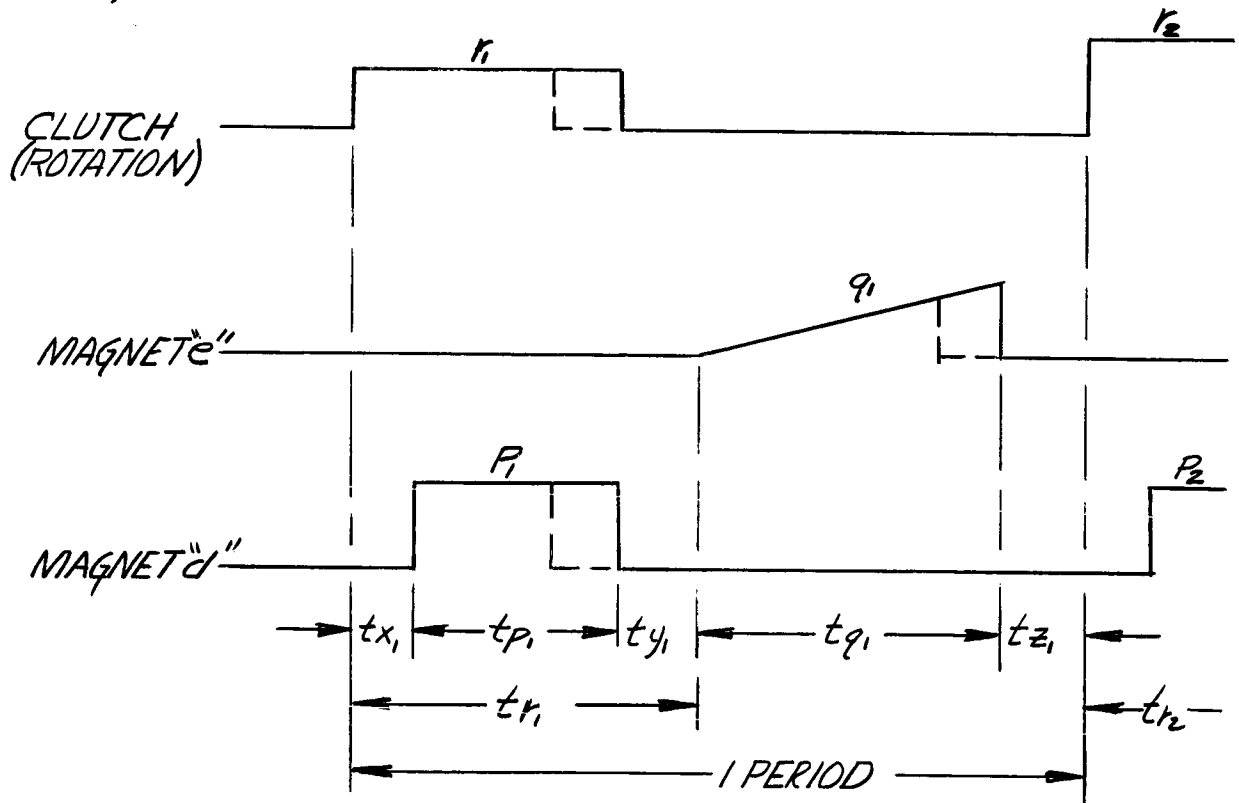



(SENSOR B Continued)

Test Schedule - For each duty cycle (test station), variation of contact pressure, p, rotation time, tr, contact time, tp, pulling time, tg, and interval times, tx, ty, and tz are as follows:

<u>Time in Seconds</u>							
<u>Test</u>	<u>p(psi)</u>	<u>tp</u>	<u>tr</u>	<u>tg</u>	<u>tx</u>	<u>ty</u>	<u>tz</u>
1	1	10	20	120	10	30	10
2	1	100	110	120	10	30	10
3	3	10	20	120	10	30	10
4	3	100	110	120	10	30	10
5	10	10	20	120	10	30	10
6	10	200	210	120	10	30	0
Total times (sec)			490	720		180	50

Total period 1440 seconds = 24 minutes

COMPLETE EXPERIMENT DATA

1. Assembly

Both sensor assemblies are installed in rectangular container together with time switch unit and instrumentation as shown in Figure A.2-12. Box top (vehicle surface) consists of flange frame and pre-stressed skin sheet. Box does not have to be sealed to ambient environment.

2. Deployment

Ground signal activates:

- a. Pyrotechnic cover release
- b. Switch Unit

Upon activation of pyrotechnic circuit, pre-stressed cover sheet rolls to one side of frame and remains in coiled condition. Ground signal is given 42 minutes before apogee position (i.e., 12 minutes prior to first duty cycle start) to permit sample surface to attain ambient pressure ( $10^{-6}$  mm Hg.).

3. Switch Unit Operation - Thirty minutes after activation by ground signal, switch unit starts timing of first duty cycle, as specified in sensor description, simultaneously on both sensors. After completion of 24-minute duty cycle, switch arrives in "0" position,

COMPLETE EXPERIMENT DATA (Continued)

deactivating all circuits, until another ground signal is given 42 minutes before second duty cycle, and so on until completion of all 5 duty cycles.

4. Power Requirements -

Total operation time = 5 cycles  
24 minute duration = 2 hours

Sensor A Magnets	300 watts	=	0.6 kwh
Sensor B Magnets	300 watts		0.6 kwh
Sensor B Motor	150 watts		0.3 kwh
Sensor B Clutch	50 watts		0.1 kwh
Switch Unit	100 watts		0.2 kwh
Instrumentation	<u>200 watts</u>		<u>0.4 kwh</u>
Total	1,100 watts		2.2 kwh

Power level during each duty cycle: 1.1 kw  
Total power requirement: 2.2 kwh

5. Reliability Provision - The time-force program of the pulling magnet d is preset and ground-calibrated. If, for any reason, the measurements or transmitter signals should be of low quality, the only important measurement, the force at welding fracture (weld strength) can still be calculated with satisfactory accuracy, as long as the time to fracture (rather than magnitude of force) can be determined for either the magnet power input or the strain gage output.

6. CONCEPTUAL DESIGN: See Figure A.2-9

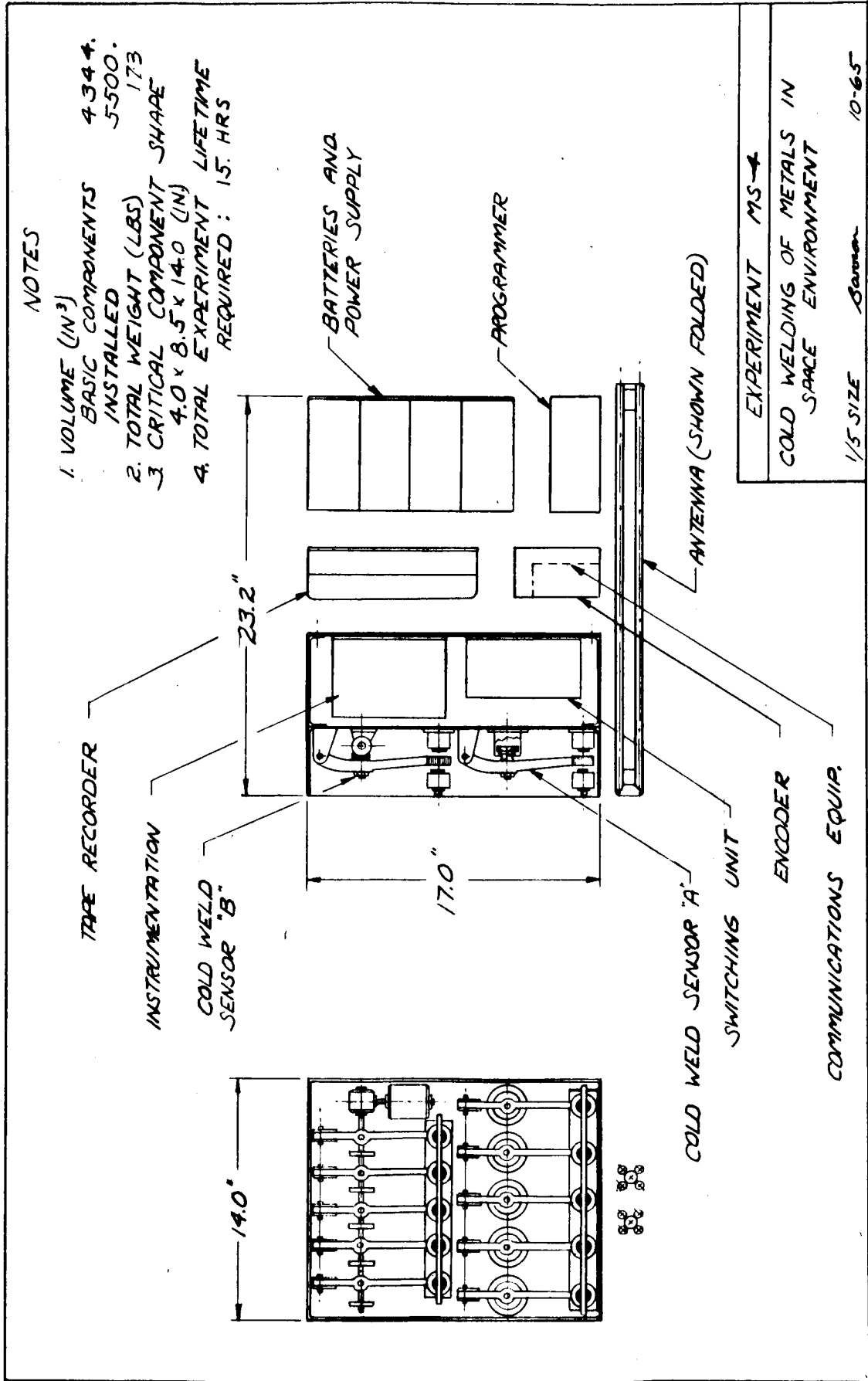

Figure A. 2-9 MS-4 CONCEPTUAL DESIGN DRAWING

1. EXPERIMENT MS-5: Spray Coating and Surface Contamination
2. TECHNICAL AREA/APPLICATIONS:
  - 2.1 GENERAL AREA: Materials and Structures
  - 2.2 EXPERIMENT APPLICATIONS:
    - a. To investigate the feasibility of using spraying techniques for outer surface coating of space vehicles, as it is required for the application and restoration of temperature control coatings.
    - b. To investigate the potential contamination of vehicle surfaces by dust or vapor due to mass forces.
3. OBJECTIVES AND SCOPE:
  - 3.1 OBJECTIVES:
    - a. Specific Objective: To perform spraying experiments at the vehicle surface and to determine (1) dispersion of the spray material, (2) coating effectiveness, and (3) contamination of remote vehicle surface by dispersed spray particles and vapor.
    - b. Key Techniques: Upon reaching orbital altitude, a spraying head and a test plate are deployed at the vehicle surface. A predetermined amount of coating material is sprayed on the test plate. The thickness and consistency of the deposit are measured and recorded. Simultaneously, potential contaminating deposits are measured at two additional vehicle locations.
  - 3.2 MEASUREMENTS AND DATA:
    - a. Phenomena to be Observed
      - (1) Coating thickness at the test plate (Sensor A).
      - (2) Vehicle surface contamination by photoelectric observation of deposit on test windows, (Sensor B).

b. Measurement Rate, Accuracy:

- (1) Sensor A: 3 pickup points, each one reading every 9 seconds, staggered; total rate = one reading every 3 seconds. Total time: 10 minutes; total of 200 readings. Accuracy:  $\pm 5\%$ .
- (2) Sensor B: One pickup point each with reading every 30 seconds for 2 hours = 240 readings; total of 480 readings for both sensors. Accuracy  $\pm 5\%$ .

3.3 FLIGHT REGIME:

a. Orbital Parameters:

- (1) Minimum eccentricity (eccentric orbits acceptable).
- (2) Vehicle altitude control desirable.

b. Duration: N/A

c. Seasonal Requirements: N/A

d. Other Flight Characteristics: Experiment precludes other experiments involving sensitive surface (e.g., optical) due to contamination. Entire program has to be planned accordingly.

e. Reasons: Contamination of entire vehicle surface is very likely. (This potential effect is one of the objectives of the experiment.)

3.4 SUPPORT EXPERIMENTATION:

a. Simultaneous Activities: N/A

b. Prerequisite Experimentation: Conventional ground development and checkout tests.

4. OPERATIONS:

4.1 DUTY CYCLE:

a. Operational Periods:

- (1) Deployment: 5 seconds (Second 0 to 5)
- (2) Spraying: 20 seconds (Second 61 to 90)
- (3) Sensor A Total operation: 10 minutes, 200 readings (Seconds 61 to 660)
- (4) Sensor B Total operation: 2 hours (Seconds 61 to 7260)

b. Interval: 55 seconds between deployment and spraying (Second 6 to 60).

c. Deployment and Operation: Ground Signal

- (1) Ignites pyrotechnic release for top cover, which coils away and exposes test plate. Spray arm swings in extended position.
- (2) Starts timer, which in turn
  - (a) Activates ultrasonic unit
  - (b) Activates Sensor B
  - (c) Activates spray unit
  - (d) Alternates pickups on Sensor A
  - (e) Terminates Sensor A operation after 10 minutes
  - (f) Terminates Sensor B operation after 2 hours

4.2 CREW REQUIREMENTS:

- a. Astronaut Participation: None. Although performance of experiment by astronaut outside the vehicle would be highly desirable, it has been deliberately omitted in order to facilitate early performance of experiment.
- b. Crew Involvement: None (See note above).

5. APPARATUS DESCRIPTION:

5.1 METHODS OF MEASUREMENT AND SENSOR DESCRIPTION:

- a. Methods of Measurement:

- (1) Deployment and operation of spray unit
- (2) Ultrasonic measurement of deposit thickness (see attached drawing) on one plate (Sensor A)
- (3) Photoelectric measurement of vehicle surface contamination at two points (Sensor B)

b. Sensor Description:

- (1) Sensor A: See Figure A.2-10
- (2) Sensor B: See Figure A.2-10

5.2 DATA COLLECTION:

- a. Format: Data recorded on tape for playback via telemetry
- b. Amount: N/A
- c. Recovery Advantages: Experiment designed to eliminate recovery. Recovery would increase effectiveness, but require redesign of experiment.

5.3 ANCILLARY EQUIPMENT: None.

SENSOR A

1. Equipment Name: Spray Assembly
2. Equipment Size Stored (lxwxh): 18 x 11 inches (surface) x 9 inches (depth)
3. Equipment Size Operating (lxwxh): 18 x 11 inches (surface) x 9 inches (depth) x 8 inches (above surface)
4. Equipment Weight: Approximately 22 pounds.
5. Power Requirements (peaks and duty cycles):  
 $50 \text{ watts} \times 2 \text{ hr} = 0.1 \text{ kwh}$   
 $600 \text{ watts} \times 10 \text{ min} = 0.1 \text{ kwh}$  total: 0.2 kwh
6. Environmental Considerations (heat output, limiting temperatures, pressurization vibration, etc.): Potential contamination of vehicle surface, other experiments (see 3.2.d,e).

7. Frequency Spectrum: N/A
8. Accuracy Considerations: Measuring accuracy as defined in ground test will be adequate.
9. Pointing Accuracy Considerations: Sun-pointing vehicle attitude stabilization will increase effectiveness of experiment.
10. Development Status: Using state-of-art techniques and instrumentation.
11. Reliability: High because of simplicity.
12. Objective:
  - a. Deployment and operation of spray unit.
  - b. Measuring of deposited coating on test plate (9 x 11 in.)
13. Measuring:
  - a. 3 ultrasonic ( $10^6 - 10^9$  cps) pickups (probes) and single energy source and responder unit; probes measured alternately, in 1 second intervals, actuated by timer.
  - b. Direct recording of measurements on tape for subsequent transmission to ground.
14. Operational Periods:
  - a. 20 seconds spraying.
  - b. 10 minutes measuring.
15. Power Requirements
  - a. Sensor A Timer: 50 watts, two hours, 0.1 kwh
  - b. Sensor A Ultrasonics: 600 watts, 10 minutes, 0.1 kwh

SENSOR B

1. Equipment Name: Contamination Sensor (2 each)
2. Equipment Size Stored (lxwxh): 3.5 inches in diameter (surface) x 6 inches deep.



(SENSOR B Continued)

3. Equipment Size Operating (lxwxh): Same as Item 2.
4. Equipment Weight: Approximately 2.5 lbs.
5. Power Requirements (peaks and duty cycles) 50 watts x 2 hrs. each, total 0.2 kwh
6. Environmental Considerations (heat output, limiting temperatures, pressurization vibration, etc.): N/A
7. Frequency Spectrum: N/A
8. Accuracy Considerations: Measuring accuracy as defined in ground tests will be adequate.
9. Pointing Accuracy Considerations: Sun-pointing vehicle attitude stabilization necessary for Sensor B operation.
10. Development Status: Using state-of-art instrumentation.
11. Reliability: High because of simplicity.
12. Arrangement: Located in various distances from Sensor A (see sketches) for (c) measuring contamination of uncoated vehicle areas.
13. Measuring: Photoelectric cell measuring change of light input through window.
14. Operational Periods: 2 hours.
15. Power Requirements:  
Sensor B -1) 100 watts, 2 hours, 0.2 kwh  
Sensor B -2)
6. CONCEPTUAL DESIGN: See Figure A.2-10.

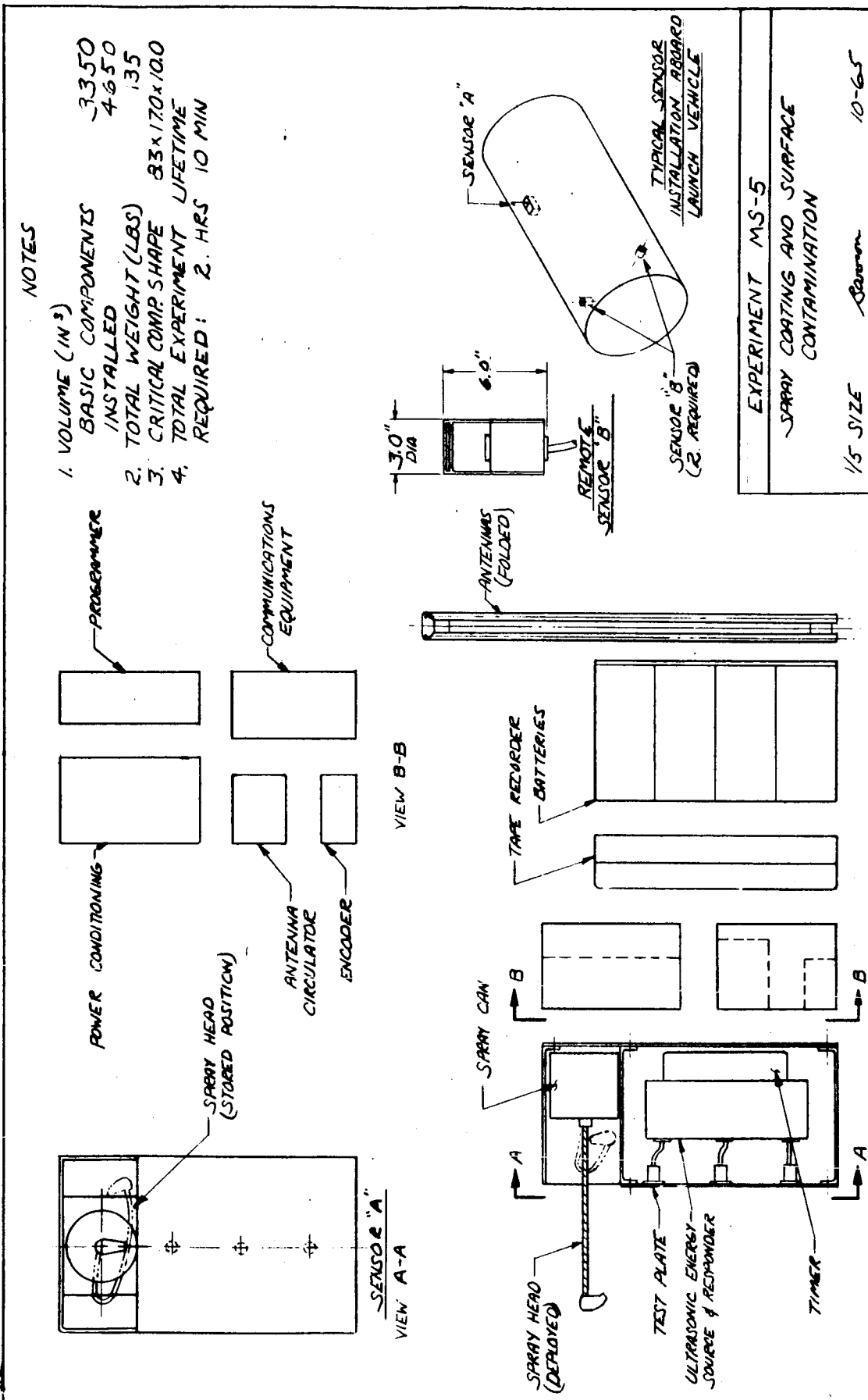

Figure A. 2-10 MS-5 CONCEPTUAL DESIGN DRAWING

### A.3

## CATEGORY III - MULTISPECTRAL IMAGERY OF THE EARTH AND ORBITING OBJECTS (MI)

The experiments in Category III provide for the observation of both orbiting objects and large areas of the Earth's surface. The five experiments in this category are designated as follows:

- MI-1: Multispectral Surveillance of Earth
- MI-2: Infrared Line-Scan Surveillance of Earth
- MI-3: Radar Surveillance of Earth
- MI-4: Electronic Image Motion Stabilization
- MI-5: Synoptic Earth Cartography.

A conceptual design drawing for each of the 5 experiments is presented on the last page of each experiment description. In many cases, illustrations and tabular data relating to the experiment are included in the final pages of the description.

1. EXPERIMENT MI-1: Multispectral Surveillance of Earth
2. TECHNICAL AREA/APPLICATIONS:
  - 2.1 GENERAL AREA: Multispectral Imagery of the Earth and Orbiting Objects
  - 2.2 EXPERIMENT APPLICATIONS: To obtain multispectral imagery and other multispectral data of selected areas of the Earth's surface to permit analysis of geographic and geologic features, agricultural and economic resources, ocean currents, snow cover and ice caps, and meteorological conditions.
3. EXPERIMENT OBJECTIVES AND SCOPE:
  - 3.1 OBJECTIVES:
    - a. Data Collection: Obtain multispectral data of selected areas of the Earth's surface. This data will consist of a set of aerial photographs and spectral radiometric data obtained simultaneously in various spectral bands of the visible and infrared spectrum (of from 0.35 to 14 microns). The selected areas of the Earth's surface will represent a variety of surface types, including farm land, forest, cities, mountains, deserts, jungles, rivers, lakes and oceans. The data will be returned to Earth, and data reduction will be accomplished on the ground.
    - b. Data Reduction: Develop data reduction techniques for the multispectral data. Advanced data reduction and data interpretation techniques will be developed to identify various types of ground targets by means of their spectral signatures, i.e., the spectral distribution of their reflected and emitted radiation in the visible and infrared spectral bands. Particular attention will be given to determination of:
      - (1) Agricultural resources (types of forestry and vegetation, status of crops, moisture conditions and irrigation requirements, etc.)

- (2) Economic resources (land utilization, Water resources, population patterns, evidences of minerals and oil, etc.)
  - (3) Geographic and geologic features (mountains, geologic formations and faults, water drainage patterns, types of soils and rocks, snow and ice cover, etc.)
  - (4) Oceanography (ocean currents, water temperature, sea state, storms, icebergs, etc.).
- c. Growth Potential: The multispectral techniques developed in this experiment will be directly applicable to future expanded programs to survey the entire earth's surface or to survey the surface of Mars and other planets.
- d. Key Techniques: This experiment is an extension of a multiband spectral technique developed by Itek Corporation for the VELA program of ARPA, under the sponsorship of the Air Force Cambridge Research Laboratories. The principal instrument in the Itek program was a special 9-lens camera, which was used to obtain nine simultaneous aerial photographs, each in a different region of the visible and near-infrared spectrum. Auxiliary equipment included infrared spectrometers and secondary cameras. Photo interpretation techniques were developed to determine the nature of various types of ground targets by analyzing their spectral signatures. A primary technique consisted of analyzing the differences between the various photographs. Some experimental work was done to produce "difference" photographs, in which false colors were arbitrarily assigned to certain spectral contrast levels in order to portray vividly the key elements of the photographs.

### 3.2 MEASUREMENTS AND DATA:

- 3.2.1 TYPES OF DATA: For each ground target area, the instrumentation equipment will be designed to obtain a set of 14 aerial photographs, each in a different

MI-1  
(Sheet 3)

spectral range, and a set of infrared spectroradiometer data. The data will consist of the following items:

- a. **Nine-lens Multiband Photographs:** A multiband camera with nine lenses will take a set of nine black-and-white photographs of the Earth's surface directly beneath the satellite. Six of the pictures will be taken on Plus-X Aerographic type film, and three will be taken on Infrared Aerographic type film. The spectral bands will be obtained by use of suitable filters over the lenses, and will be approximately as follows: 0.40-0.50 micron, 0.45-0.51 micron, 0.52-0.55 micron, 0.55-0.60 micron, 0.59-0.64 micron, 0.67-0.72 micron, 0.70-0.81 micron, 0.81-0.90 micron, and one photo covering the full sensitivity range of the infrared film.
- b. **Color Photographs:** Two small cameras will take a set of two color photographs of the Earth's surface directly beneath the satellite. One of the pictures will be taken on Ektachrome-type film, and the other will be taken on Infrared Ektachrome-type film.
- c. **Wide-Angle Photograph:** One small camera with a wide-angle lens will take a black-and-white photograph of the Earth's surface directly beneath the satellite. The purpose of this photograph is to provide a wide area scene to aid in the geographic orientation of the other photographs.
- d. **Stereo Photographs:** Two cameras will take a pair of stereo photographs of the Earth's surface. One of the cameras will be installed to look forward at an angle of 15 degrees from the vertical, and the other camera will be installed to look aft at an angle of 15 degrees from the vertical. The stereo photograph will cover the same ground area as the multiband photographs and the color photographs (items a and b above). It

is recommended that one of the photographs be taken in black-and-white and the other in color, although both can be in black-and-white, if desired.

- e. Infrared Spectroradiometer Data: Three spectroradiometers of the scanning interferometer type will sense the radiation intensity from the Earth's surface in the wavelength bands from 0.35 to 14 microns. The spectroradiometers will be aligned so that the radiometric data is from the same ground area as the multiband photographs and the color photographs (items a and b above).
- f. Auxiliary Data: Navigation data and sensor pointing data must be recorded to facilitate the data reduction of the aerial photographs and infrared spectroradiometric data. As a minimum time must be recorded for each set of data, with a precision of 0.1 second or better. Orbit ephemeris data must be available during the data reduction process in order to determine the geographic position and orientation of each photograph.

### 3.2.2 GENERAL DATA REQUIREMENTS:

- a. Resolution: The multiband camera will be designed to have a resolution of at least 50 lines/mm in the focal plane. With a focal length of 300 mm, this is equivalent to an angular resolution of about 13.5 arc seconds. At an altitude of 185 kilometers (100 n.mi.), this is equivalent to a ground resolution of 12 meters (about 40 feet). The resolution of the color cameras and the stereo cameras will be about the same as that of the multiband camera.
- b. Data Rate: During a data run, the cameras and spectroradiometer must be able to obtain a complete set of data once every three seconds. A typical data run will last for about one minute, and will continue about 20 sets of data. The stereo cameras may run longer than the other sensors by a factor of about 25 per cent to ensure complete stereo coverage of the ground area covered by the other sensors. The total mission will contain about 40 data runs, each of about one-minute duration.

- c. Typical Target Areas: Prior to flight, a number of typical target areas will be selected on the earth's surface. These will include farm lands, cities, mountains, jungles, forests, rivers and oceans. All of these areas should be accessible areas so that ground inspections can be made to verify or check the validity of the satellite data. Alternate sites of each general type should also be picked so that data runs can be performed in case bad weather prevents data acquisition of the primary sites.
- d. Pointing Accuracy: The field of view of each sensor, except the wide-angle camera, is about 11 degrees. The field of view of the wide-angle camera is about 41 degrees. The sensors will be aligned so that all of them point in the same direction, except the stereo cameras which are pointed 15 degrees fore and aft. The sensor package is nominally pointed straight down at the ground nadir point beneath the satellite. However, since the selected ground targets in most cases will not lie directly beneath the satellite, provisions must be incorporated which permit the sensors to be pointed to either side of the flight path, up to  $\pm 30$  degrees from the vertical. An obvious means of accomplishing this is to roll the entire vehicle. If this is not feasible, it will be necessary to incorporate provisions for rotating the line of sight of the sensor package itself. The pointing of the sensor package should be accurate to within  $\pm 1.5$  degrees.
- e. Image Motion Compensation: In order to meet the resolution requirements, each camera is provided with moving-film-type image-motion compensation (IMC). Based on a nominal shutter speed of 0.02 second, the IMC must be controlled to within  $\pm 2.5$  percent. The IMC is based on the V/H ratio (velocity/height) of the vehicle, which can be obtained from the navigation system or from a separate V/H sensor installed specifically for the purpose. Each of the cameras must be installed so that the direction of the moving film IMC is parallel to the effective ground track vector to within  $\pm 1.5$  degrees. An obvious means of accomplishing this is to align the vehicle itself



MI-1  
(Sheet 6)

parallel to the ground track vector. If this is not feasible, it will be necessary to provide a local means of aligning the sensor package with the ground track.

3.3 FLIGHT REGIME:

- a. Altitude above Terrain: Most of the data runs will be performed over the United States. Data runs taken over land should, if possible, be performed at altitudes of from 185 to 250 kilometers (100 to 135 n.mi.) above terrain. Data runs over land at altitudes between 250 and 370 kilometers may be useful for some purposes, but are judged to have reduced effectiveness as the altitude increases; altitudes above 370 kilometers (200 n.mi.) are judged not acceptable for this experiment. Data runs over the ocean may be at higher altitudes, with acceptable performance up to about 370 kilometers. A near-circular orbit is convenient for this experiment; but is not essential, provided the data runs occur within the acceptable ranges defined above.
- b. Illumination Conditions: The primary sensors in the instrument package are photographic cameras, and they require daylight illumination. The illumination will be judged to be acceptable, provided the sun angle is at least 30 degrees above the Earth horizon, measured at the Earth's surface.
- c. Orbit Inclination: The inclination must be great enough to cover the latitude of all the selected target areas. If ice cover and icebergs are included in the list of desired targets, it will be necessary to select a time of year and an inclination which will permit daytime surveillance of these targets, and a near-polar orbit will be indicated. For all targets in the temperature zones, the inclination of the orbit is not critical, and all that is necessary is to provide daytime surveillance over the selected targets.

- d. **Seasonal Requirements:** Certain aspects of the experiment may have seasonal variations. For example, agricultural conditions and the status of crops vary considerably with the time of year. Similarly, ocean currents and water temperature vary with the time of year. For this reason, this experiment should be repeated at different times of the year; and at least two experiments--one in the summer and one in the winter--are indicated as a minimum. Additional flights in the spring and fall are also desirable. If suitable target sites in the southern hemisphere are selected, it may be possible to combine some summer and some winter conditions on the same flight.
  
  - e. **Duration of Experiment:** The duration of the experiment depends on the location of the selected target areas and on the weather visibility conditions over these targets. If the selected targets are commensurate with the orbit path, and if these targets are not obscured by clouds, it should be possible to obtain 40 data runs over a variety of targets in two or three days, or less. On the other hand, longer mission durations of two weeks or longer are desirable in order to improve the probability of obtaining data from all the desired targets.
- 3.4 **SUPPORT EXPERIMENTATION:** Since the final result of the experiment will be a photographic interpretation of selected target areas, it is necessary to check the validity of the interpretation by means of ground inspection or airplane inspection of the target areas. In the case of oceanographic targets, the validation must be done at approximately the same time that the satellite photos are taken. In the case of agricultural or economic targets, the validation must be done within a few days of the time that the satellite photos are taken. These validation checks will enable the experimenters to build up confidence in their data interpretation techniques, and will eventually lead to building up a catalog of key spectral signatures which can be used in the interpretation of unknown target areas.

4. OPERATIONS:

- 4.1 DUTY CYCLE: The total data collection operation will consist of 40 data runs, each data run being approximately one minute in duration. The data runs will be taken over preselected target areas on the Earth's surface. All data runs will be taken during daylight conditions; none will be taken at night. If a target area lies to the right or left side of the ground track, it will be necessary prior to the data run to point the line of sight of the sensor package to the right or left so that the target will be in the field of view. This may be done either by rolling the entire vehicle or by rotating portions of the sensor package.
- 4.2 CREW REQUIREMENTS: Astronaut participation in the experiment is not essential. However, if the services of the astronaut are available, he could be helpful in two areas, and it would also be possible to simplify the overall system. The two areas of possible crew participation are:
- a. Target Identification: If crew participation is not used, the sensors will turn on and off either by programmed command or by telemetered commands from ground stations. If the services of the crew are available, the judgment of the astronaut could be used instead to decide whether the targets are visible and whether the sensors should be turned on or off.
  - b. Film Retrieval: At the end of the experiment when the cameras have completed their job, it will be necessary to remove the film from the cameras, in a light-proof manner, and to return the film to earth for processing and data reduction. If crew participation is not used, it will be necessary to provide an automatic means of loading the exposed film into a returnable cassette, perhaps similar to a Discoverer reentry capsule. On the other hand, if the services of the astronaut are available, it may be possible for the astronaut to bring the film cassette into the Command Module for the return to Earth.

5. APPARATUS DESCRIPTION:

5.1 METHODS OF MEASUREMENT AND SENSOR DESCRIPTION: The sensor package is an integrated package consisting of six photographic cameras, three scanning spectroradiometers, and one V/H sensor. All of the sensors are installed and aligned so that their lines of sight are pointed in the same direction (except the stereo cameras, which are tilted for and aft to provide the correct stereo viewing angle). The details of each sensor are given below:

- a. Multiband Camera: Contains 9 lenses, each with 300-mm focal length, contains 3 rolls of 70-mm film, each 500 feet long, format  $2\frac{1}{2} \times 2\frac{1}{2}$  inches, with IMC.
- (1) Equipment size: About 22 inches high x 12 inches x 12 inches, both stored or operating.
  - (2) Equipment weight: About 25 pounds, not including film. Power requirements: About 200 watts during operation.
  - (3) Duty cycle: Takes pictures during 40 data runs, each approximately one minute in duration. Cycling rate is one set of 9 pictures approximately every 3 seconds.
  - (4) Environmental considerations: Maintain temperature of film and camera between 5 and 35°C; pressurization is probably not required except on missions longer than about 7-10 days (film becomes brittle when it dries out in a hard vacuum).
  - (5) Pointing accuracy: To within  $\pm 1.5$  degrees (see paragraph 3.2.2, Item d).
  - (6) Development status: Nonexistent; this design would be a modified design of an existing 9-lens multiband camera built by Itek; the principal modification is the use of 12-inch lenses instead of 6-inch lenses.

MI-1  
(Sheet 10)

- (7) Reliability: Unknown, should be quite high since standard aerial cameras are fairly reliable.
- b. Color Cameras: Two cameras, each with 300-mm focal length lens, format  $2\frac{1}{2} \times 2\frac{1}{2}$  inches, with IMC, each containing one roll of 70-mm film about 200 feet long. Film types are Ektachrome and Infrared Ektachrome.
- (1) Equipment size: Each camera about 20 inches high x 8 inches long x 5 inches wide, both stored and operating.
- (2) Equipment weight: About 15 pounds each, not including film.
- (3) Power requirements: About 100 watts each during operation.
- (4) Duty cycle: Takes pictures during 40 data runs, each approximately one minute in duration. Cycling rate is approximately one picture per 3 seconds.
- (5) Environmental considerations: Maintain temperature of film and camera between 5 and 35 degrees Centigrade; pressurization is probably not required except on missions longer than about 7-10 days.
- (6) Pointing accuracy: To within  $\pm 1.5$  degrees (see paragraph 3.2.2, Item d).
- (7) Development status: These cameras may be a modification of an existing camera type, such as the Maurer P-220.
- (8) Reliability: Unknown, probably fairly good.
- c. Wide-angle Camera: This camera is for general orientation purposes. It has a 75 mm focal length lens, with a  $2\frac{1}{2} \times 2\frac{1}{2}$  inch format, and contains one roll of 70-mm film about 200 feet long.

MI-1  
(Sheet 11)

- (1) Equipment size: About 11 inches high x 8 inches long x 5 inches wide, both stored and operating.
  - (2) Equipment weight: About 10 pounds, not including film.
  - (3) Power requirements: About 100 watts during operation.
  - (4) Duty cycle: Takes pictures during 40 data runs, each approximately one minute in duration. Cycling rate is approximately one picture per 3 seconds.
  - (5) Environmental considerations: Maintain temperature of film and camera between 5 and 35°C; pressurization is probably not required except on missions longer than about 7 to 10 days.
  - (6) Pointing accuracy: To within + 1.5 degrees (see paragraph 3.2.2, Item d).
  - (7) Development status: This camera may be a modification of an existing camera type, such as the Maurer P-220.
  - (8) Reliability: Unknown, probably fairly good.
- d. Stereo Cameras: Two cameras, installed in a fore-and-aft convergent stereo configuration, each camera installed at an angle of 15° from the vertical. Each camera has a 300-mm focal length, 2½ x 2½ inch format, and contains one roll of 70-mm film about 200 feet long.
- (1) Equipment size: Each camera about 20 inches high x 8 inches long x 5 inches wide, both stored and operating.
  - (2) Equipment weight: Each camera about 15 pounds, not including film.
  - (3) Power requirements: About 100 watts each during operation.

MI-1  
(Sheet 12)

- (4) Duty cycle: Takes pictures during 40 data runs, each about 1.25 minutes in duration (The length of each data run is longer for the stereo cameras than for the other sensors because of the convergent stereo angle). Cycling rate is approximately one picture pair per 3 seconds.
  - (5) Environmental considerations: Maintain temperature of film and cameras between 5 and 35 degrees Centigrade; pressurization is probably not required except on missions longer than about 7 to 10 days.
  - (6) Pointing accuracy: To within  $\pm 1.5^{\circ}$  (see paragraph 3.2.2, Item d).
  - (7) Development status: These cameras may be a modification of an existing camera type, such as the Maurer P-220.
  - (8) Reliability: Unknown, probably fairly good.
- e. Spectroradiometers: Three units, each of the scanning Michelson interferometer type.
- (1) Operating bands: One unit in the spectral range from 0.35 to 0.94 microns, another unit from 0.8 to 3.5 microns, and the third unit from 7.5 to 14 microns.
  - (2) Equipment size: Each unit about 6 inches high x 6 inches long x 4 inches wide, both stored and operating.
  - (3) Equipment weight: Each unit about 5 pounds.
  - (4) Power requirements: Estimated each unit 30 watts.
  - (5) Duty cycle: Takes radiometric data during 40 data runs, each about 1 minute in duration.
  - (6) Data recording: On magnetic tape.

MI-1  
(Sheet 13)

- (7) Field of view: 11 degrees, to match photographic cameras.
  - (8) Environmental considerations: Careful vibration isolation is required. Estimated temperature requirements are to maintain each unit at about  $20 \pm 5$  degrees Centigrade.
  - (9) Pointing accuracy: To within  $\pm 1.5$  degrees (see paragraph 3.2.2, Item d).
  - (10) Calibration: Each unit contains an internal reference black body which will be monitored before and after each data run.
  - (11) Development status: The units may be a modification of an existing type of spectroradiometer, such as units designed and built by Block Associates.
  - (12) Reliability: Unknown.
- f. V/H Sensor: This is an auxiliary sensor for the purpose of providing correct image motion compensation (IMC) command signals to the photographic cameras; it senses the angular velocity required for optically tracking an object on the earth's surface and sends this signal (V/H) to the camera control system.
- (1) Equipment size: About 10 inches high x 5 inches x 5 inches.
  - (2) Equipment weight: About 5 pounds.
  - (3) Power requirements: Estimated about 15 watts.
  - (4) Duty cycle: Same as cameras.
  - (5) Environmental considerations: None.
  - (6) Pointing accuracy: Same as cameras.
  - (7) Development status: Nonexistent.. May be designed and built based on modifications of existing V/H sensors, such as have been built by various manufacturers, including Perkin-Elmer, Chicago Aerial Industries, Goodyear Aerospace, and Itek.



- (8) Reliability: Unknown.
- (9) Aternate approach: The V/H sensor may be eliminated if the vehicle velocity and the altitude above terrain can be obtained from other sources, such as the vehicle navigation system and a suitable altimeter.

## 5.2 DATA COLLECTION:

- a. Data format: All photographic cameras use 70-mm film with  $2\frac{1}{2} \times 2\frac{1}{2}$  inch formats; some of these photographs are in black-and-white and some are in color. The spectroradiometer data is recorded on magnetic tape; three channels are required, one for each unit; the signals are analog and will require a bandwidth not exceeding about 6 kilocycles/second.
- b. Total bulk of data: The total mission requires 40 data runs, each about one minute in duration. The total data consists of 8 rolls of photographic film and one roll of magnetic tape, as follows:
  - (1) 3 rolls of 70-mm film x 500 feet long (weight 5 pounds per roll, spool diameter 7 inches per roll).
  - (2) 5 rolls of 70-mm film x 200 feet long (weight 2 pounds per roll, spool diameter 4.5 inches per roll).
  - (3) 1 roll of magnetic tape with at least 3 channels, 750 feet long (weight 1 pound, 5-inch diameter).
- c. Data return to Earth: The 8 rolls of photographic film must be physically returned to earth, either in a reentry capsule like the Discoverer capsule or in the Command Module with the astronauts. The data recorded on magnetic tape can either be physically returned to earth along with the photographic film, or it can be telemetered back to a ground station.

- d. Data correlation: The photographic film and the magnetic tape must include correlation index data to identify each set of data. This index data will include time accurate to 0.1 second, and any other significant data such as orbit ephemeris data, navigation data, and the pointing angle of the sensor line-of-sight. This data will facilitate correlation of the various photographs and spectrographic data with each other, and will enable the data interpreters to determine the geographic position and orientation of each photograph and each data block on the magnetic tape. The other navigational data and pointing data may be recorded on an extra channel of the magnetic tape, if desired.

5.3 ANCILLARY EQUIPMENT: The following supporting equipment will be required:

- a. Magnetic tape recorder: For recording the spectroradiometer data and the auxiliary navigation and pointing data.
- b. Telemetering equipment: For transmitting the magnetic tape data back to a ground station. This may not be needed for this experiment if the magnetic tape is physically returned to Earth.
- c. Power supply.
- d. Programmer: This will be needed to turn the sensors on and off for each of the 40 data runs over the selected target areas. It may also be required to send signals to the vehicle attitude control system to roll the sensor line of sight so that the target areas will be in the sensor field of view (see paragraph 3.2.2, Item d). An alternate approach is to do the programming on the ground and to transmit the programming commands to the equipment in the vehicle.
- e. Environmental control equipment.

6. CONCEPTUAL DESIGN: See Figure A.3-1

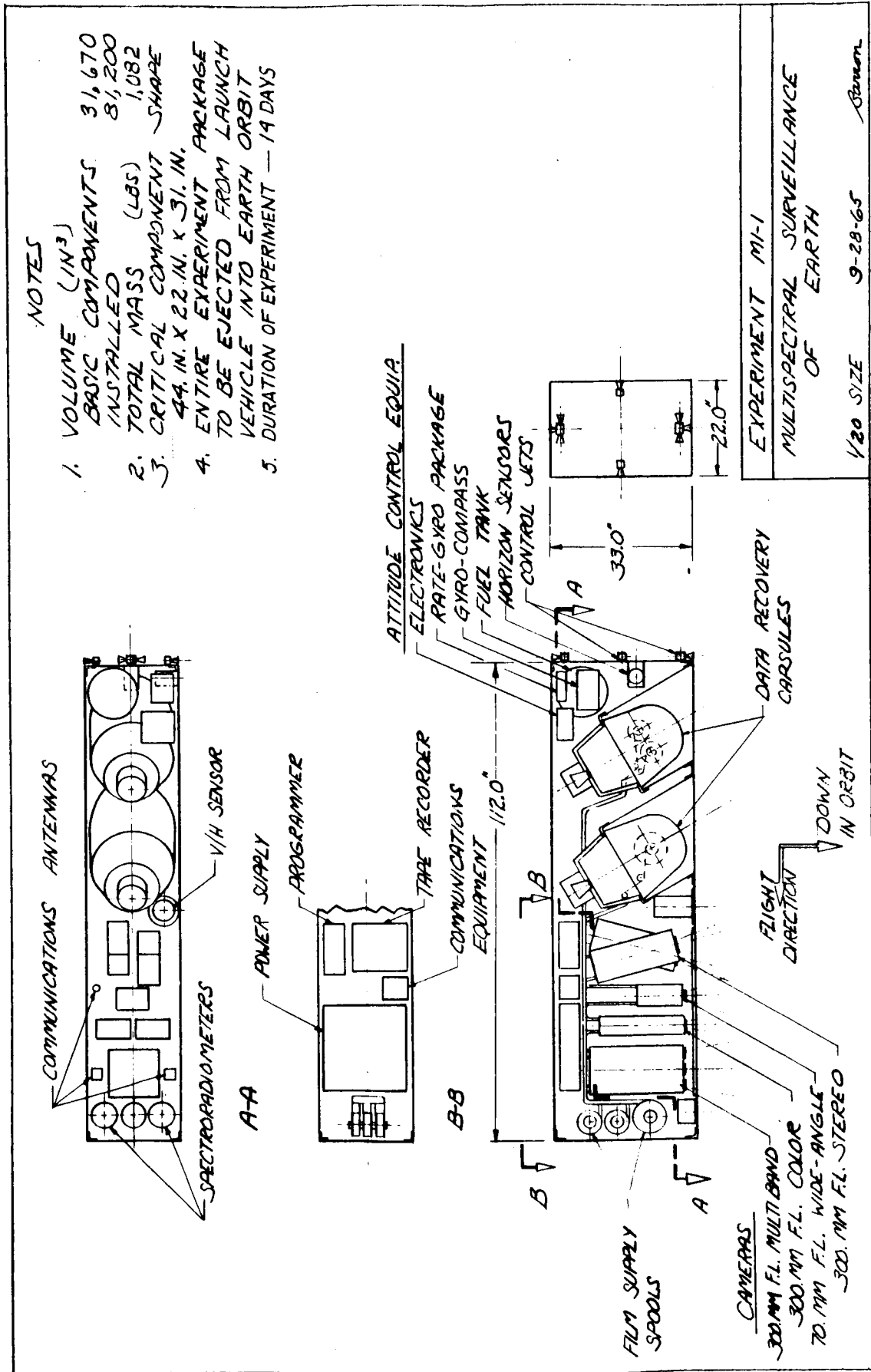

Figure A. 3-1 MI-1 CONCEPTUAL DESIGN DRAWING

1. EXPERIMENT MI-2: Infrared Line Scan Surveillance of Earth
2. TECHNICAL AREA/APPLICATIONS:
  - 2.1 GENERAL AREA: Multispectral Imagery of the Earth and Orbiting Objects.
  - 2.2 EXPERIMENT APPLICATIONS: To obtain day and night infrared imagery of selected areas of the Earth's surface to permit analysis of geographic and geological features, man-made hot spots (such as factories and power plants), ocean currents, snow cover and ice caps, and cloud cover.
3. EXPERIMENT OBJECTIVES AND SCOPE:
  - 3.1 OBJECTIVES:
    - a. Specific Objectives: Develop and test a satellite-borne infrared line scanner. Obtain infrared imagery of selected areas of the Earth's surface under both day and night time conditions. The selected areas of the Earth's surface will represent a variety of surface types, including farm lands, forests, cities, mountains, rivers, lakes and oceans. The data will be temporarily stored on video tape and telemetered back to ground stations at convenient intervals. The images will be reconstructed on the ground, both as video displays and as line-scan photographs. The displays and photographs will be analyzed to determine (1) geographic and geological features, (2) man-made hot spots (factories and power plants), (3) ocean currents, (4) snow cover and ice caps, and (5) cloud cover. The difference between day and nighttime operation will also be investigated.
    - b. Key Techniques: The line scanner utilizes a rotating mirror optical assembly to generate a transverse line scan and to focus the infrared radiation onto a sensitive infrared detector. The technique is similar in concept to that of existing line-scan devices which have been developed for use in reconnaissance airplanes by such companies as HRB-Singer, Texas Instruments, and Servo Corporation of America.

c. Growth Potential: The techniques developed in this experiment will be useful for future systematic surveillance of the Earth's surface and for surveillance of the Moon and Mars. Of particular importance is the ability to perform surveillance under nighttime conditions.

3.2 MEASUREMENTS AND DATA: The data collected in this experiment is a continuous strip image of the Earth's surface underneath the satellite. The strip image is generated one scan line at a time by means of a rotating mirror optical assembly which focuses the infrared radiation onto a sensitive infrared detector. In the vehicle the image exists in the form of a video signal having a bandwidth of about 3.0 megacycles per second. It is stored temporarily on video tape and telemetered to ground station at convenient intervals. On the ground the image is reconstructed into either a video display on a CRT monitor or a line-scan photograph.

a. Resolution: The instantaneous field of view corresponding to a single detector (i.e., one spot size) will be 0.10 milliradian in the along-track direction by 0.14 milliradian in the cross-track direction. For a nominal altitude of 185 kilometers (100 n.mi.), this is equivalent to a ground resolution of 52 meters per line pair (170 feet per line pair). This resolution estimate includes a "Kell factor" of 0.71 in the direction of flight. Also it may be noted that one "line pair" is equivalent to two "TV lines."

b. Swath Width: Transverse scan of  $\pm 60$  degrees. For a nominal altitude of 185 kilometers, the ground swath width will be 640 kilometers (346 n.mi.).

c. Infrared Wavelength: Operation is recommended in the 8- to 13-micron region, since this is an atmospheric window and is the region in which peak radiation occurs for objects at normal outdoor temperatures (about 250 to 320 degrees). An alternate region which could be used is the band of from 3 to 5 microns.

MI-2  
(Sheet 3)

- d. Data Rate: Continuous during a data run; the bandwidth is about 3.0 megacycles per second.
- e. Pointing Accuracy: Verticality should be maintained to within  $\pm 2$  degrees. The scanner should be aligned in azimuth with the effective ground track to within about  $\pm 3$  degrees. The vehicle (or at least the infrared scanner) should be stabilized in roll, pitch, and azimuth to within less than 400 arc seconds per second.
- f. V/H Rate: The scan rate of the scanner is proportional to the V/H rate. The V/H rate is the angular velocity required to track an object on the ground, and is equal to the velocity of the vehicle divided by the altitude above the Earth's surface. The scanner will obtain the V/H rate signal from the vehicle navigation system and from an altimeter. The V/H rate should be accurate to within  $\pm 5$  per cent.
- g. Auxiliary Data: Navigational data and time index data, together with appropriate fiducial marks, will be recorded so that the photo interpreter will be able to determine the geographic position and orientation of any object in the infrared strip photograph. The fiducial marks will be introduced into the video signal at appropriate times. The navigational data and time index data will be recorded on an auxiliary audio channel of the video tape. The time index will correspond to the fiducial marks, and will be recorded at least once every five or ten seconds, with a precision of 0.1 second or better.

3.3 FLIGHT REGIME:

- a. Orbital Parameters: The infrared surveillance data runs should be performed at altitudes of about 185 to 250 kilometers above the Earth's surface (100 to 135 n.mi.). The ground resolution degrades as the altitude increases, and altitudes above 370 kilometers will be considered unacceptable for this experiment. A near-circular orbit is desirable, but is not essential. The inclination of the orbit is not critical.

- b. In-flight Duration of Experiment: This is not critical; it may range from two or three days to several weeks.
- c. Diurnal and Seasonal Requirements: Both day and night surveillance is required of selected areas of the Earth's surface. Since infrared radiation will not penetrate through clouds, it is necessary to have reasonably clear weather over the major areas of interest. Seasonal requirements are not critical, but it would be desirable to compare the results of a summer flight with a winter flight.
- d. Vehicle Attitude Control: The attitude of the vehicle must be controlled sufficiently to meet the pointing accuracy requirements specified in paragraph 3.2, Item e.

3.4 SUPPORT EXPERIMENTATION: The infrared photographs contain images of selected target areas on the earth's surface. For comparison purposes, it is desirable to have a set of aerial photographs of the same target areas. In the case of ocean currents and other targets which vary from time to time, the aerial photographs should, if possible, be taken at about the same time as the infrared strip picture; however, this may involve a delay of several hours because the infrared picture may be taken at night and the aerial photograph can be taken only during the day.

#### 4. OPERATIONS:

4.1 DUTY CYCLE: The infrared strip pictures are recorded on video tape which has a total recording capacity of about one hour. This amount of data will be accumulated in segments, which are taken on different orbits and at different times of day and night. On a typical mission, the 1-hour recording capacity may be made up of about 15 or 20 separate data runs, each averaging about 3 or 4 minutes long. The video recording will be done in real time with a bandwidth of about 3.0 megacycles per second. At a later time the data will be telemetered back to one or more ground

stations, either directly or by way of a relay communications satellite. The transmission will probably be done at a relatively slow rate, perhaps at a bandwidth of about 500 kilocycles per second. This will require a total satellite-to-ground transmission time of about 6 hours; however, this can not be done at one time but must be done piece-meal over a period of many hours, since the transmission can take place only when the transmitter is within line-of-sight of the receiving station. This seriously restricts the transmission time, particularly for a low-altitude orbit, and it is therefore recommended that a high-altitude relay communications satellite be used to transmit the infrared picture to the ground. After the data on the video tape has been transmitted, the tape can be erased and used again for another set of data runs, if desired. On long missions, if a relay communications satellite is used for transmitting to the ground, it is estimated that it will be possible to obtain and transmit about one hour of data runs per day. If a relay communications satellite is not used, the rate will be much slower--about one hour of data runs every three weeks.

4.2 CREW REQUIREMENTS: Astronaut participation is not required in this experiment. However, one possible use of an astronaut would be to physically recover the video tape (one reel about 10½ inches in diameter) and bring it back to earth in the Command Module.

## 5. APPARATUS DESCRIPTION:

### 5.1 METHODS OF MEASUREMENT AND SENSOR DESCRIPTION:

Three items of equipment will be described: an infrared line scanner, a video tape recorder, and a power supply.

a. Infrared Line Scanner: The infrared line scanner proposed for this experiment has not been developed at the present time, but it is considered feasible under the present state of the art. It is similar in concept to existing line scanners which have been built for use in reconnaissance airplanes. The



MI-2  
(Sheet 6)

following description of the performance and physical characteristics is a preliminary estimate, and may be subject to moderate changes after the trade-offs are considered during a development program.

- (1) Equipment name: Infrared line scanner.
- (2) Equipment size: About 24L x 20W x 15H inches, both stored and operating.
- (3) Equipment weight: About 100 pounds, not including power supply.
- (4) Power requirements: Estimated 700 watts during operation of the scanner. See duty cycle requirements, paragraph 4.1.
- (5) Environmental considerations: The infrared detectors will be cooled to about 20 degrees Kelvin by a self-contained closed cycle cooling unit located in the infrared scanner package.
- (6) Wavelength: The operating region will probably be from 8 to 13 microns. The specific detector has not been selected, but may possibly be zinc-doped or gold-doped germanium.
- (7) Installation considerations: The line scan is generated by a rotating mirror optical assembly. Since the line scan must be transverse to the ground track, it will be necessary to install the line scanner so that the axis of rotation of the mirror assembly is parallel to the ground track. Optical clearance is required for a 120-degree transverse field of view. A window is not required.
- (8) Pointing accuracy: See paragraph 3.2, Item e.
- (9) V/H rate: See paragraph 3.2, Item f.

MI-2  
(Sheet 7)

- (10) Scan Rate: About 400 scan lines per second. This is based on a spot size of 0.10 milliradian in the along-track direction, and a V/H rate of about 0.04 radian per second.
  - (11) Elements per scan line: About 15,000 elements (spots) per line. This is based on a spot size of 0.14 milliradian in the cross-track direction and a transverse scan of 120 degrees.
  - (12) Bandwidth: About 3.0 megacycles per second. This is based on direct analog recording of the video signal. Digital recording is not considered feasible.
  - (13) Optical aperture: At least 15 cm (6 inches).
  - (14) Development status: Nonexistent, will be similar to existing line scanners built for use in reconnaissance airplanes.
  - (15) Reliability: Unknown, probably moderate in the first test models.
- b. Video Tape Recorder: The estimated characteristics of a satellite-borne video tape recorder are as follows:
- (1) Equipment name: Video tape recorder.
  - (2) Equipment size: About 30L x 18W x 12H inches, both stored and operating.
  - (3) Equipment weight: About 95 pounds, including one reel of tape, but not including power supply.
  - (4) Power requirements: About 300 watts during operation, both recording and real-outs into the transmitter. See duty cycle requirements, paragraph 4.1.
  - (5) Environmental considerations: None

MI-2  
(Sheet 8)

- (6) Bandwidth: Video recording about 3.0 megacycles per second. At least one auxiliary audio channel for navigational and time index data, 15 kilocycles per second bandwidth.
- (7) Recording capacity: One hour total, one reel of 2-inch tape, 1.0-mil mylar, on 10½-inch reel.
- (8) Tape speed: 12.5 inches per second (recording).
- (9) Development status: Modification of existing airborne tape recorders.
- (10) Reliability: Unknown, probably about 4,000 hours MTBF.

c. Power Supply: This unit will provide proper voltages for the infrared line scanner and the video tape recorder. The estimated size is about 12L x 12W x 12H inches. The estimated weight is about 30 pounds.

5.2 DATA COLLECTION: The infrared line scan data is recorded on video tape, then transmitted to ground stations by way of a relay communications satellite. The recording capacity is one hour per reel of tape. This amount of data can be transmitted back to the ground at an average rate of about one reel per day (see paragraph 4.1 for a description of the duty cycle). There is no requirement for physical recovery of the tape.

5.3 ANCILLARY EQUIPMENT:

a. Telemetry Transmitter: This is required to transmit the video signals from the satellite to ground stations by way of a relay communications satellite. The transmitter should have a capability of transmitting signals with a bandwidth of at least 500 kilocycles per second; a wider bandwidth capability is desirable.

MI-2  
(Sheet 9)

- b. Programmer: This is required to turn the infrared line scanner and the video tape recorder on or off at appropriate times. An alternate approach is to turn the equipment on or off in accordance with command signals from ground stations.
6. CONCEPTUAL DESIGN: See Figure A.3-2.

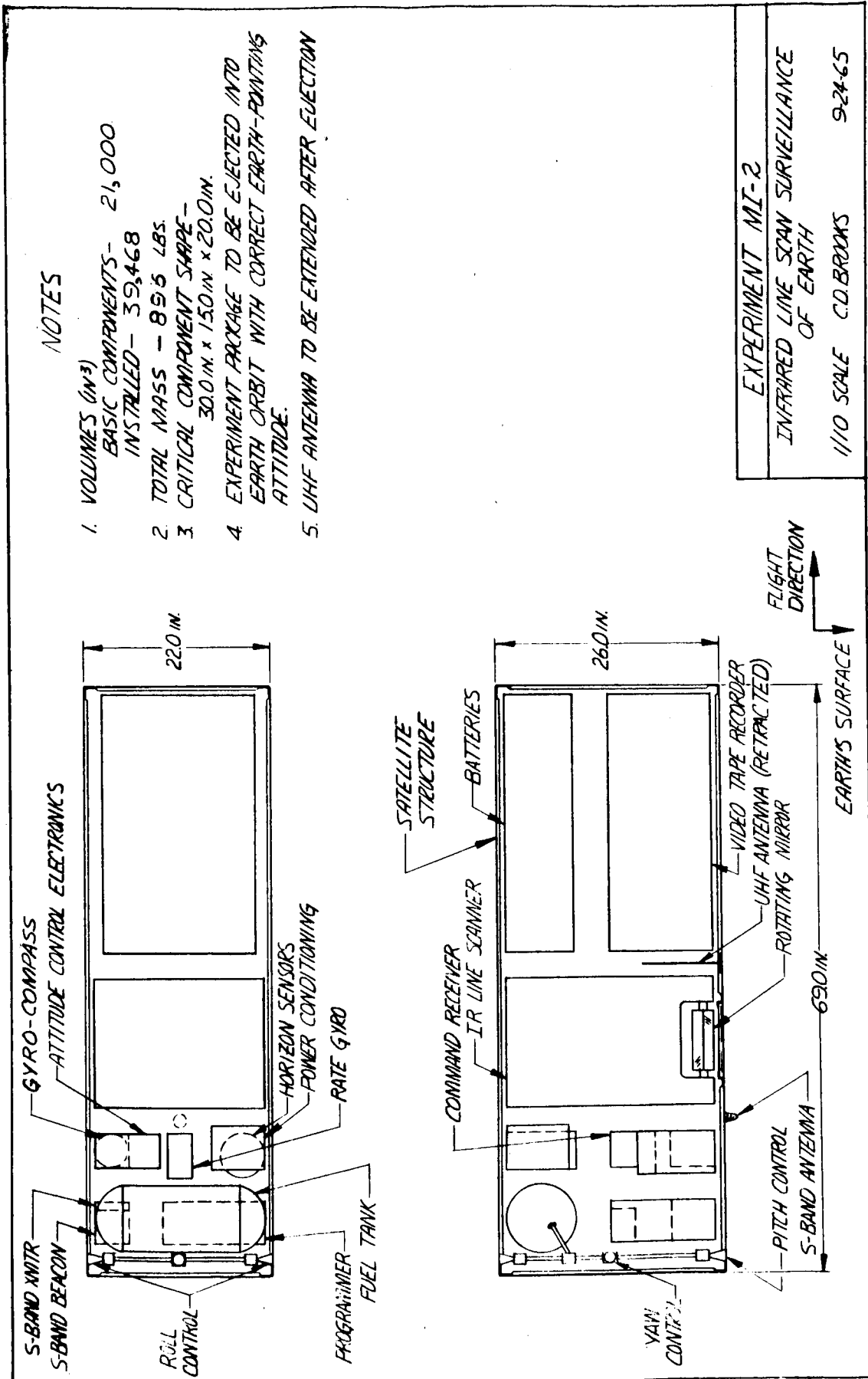

Figure A. 3-2 MI-2 CONCEPTUAL DESIGN DRAWING

1. EXPERIMENT MI-3: Radar Surveillance of Earth
2. TECHNICAL AREA/APPLICATIONS:
  - 2.1 GENERAL AREA: Multispectral Imagery of the Earth and Orbiting Objects
  - 2.2 EXPERIMENT APPLICATIONS: To obtain high-resolution side-looking radar images of selected portions of the earth's surface. This can be done under both day and night conditions and through normal cloud cover.
3. EXPERIMENT OBJECTIVES AND SCOPE:
  - 3.1 OBJECTIVES:
    - a. Specific Objectives: The primary objective is to develop a capability of obtaining high-resolution radar images of the earth's surface by means of a satellite-borne coherent data processing side-looking radar. Data processing of the radar image will take place during flight.
    - b. Key Techniques: Modern high-resolution side-looking radars have been developed for use in airplanes, by groups such as the University of Michigan, Goodyear Aerospace, and Conductron. Similar techniques can be used to develop side-looking radars for use in orbiting satellites. The high-resolution side-looking radar utilizes the principle of a synthetic aperture which is many times longer than the physical length of the antenna. As the vehicle moves, the side-looking beam scans across each target on the ground. Because of the horizontal beam width, each target is sampled several times (on successive sweeps). Each sample return signal from a target has a characteristic time-phase relationship with respect to a standard reference frequency. The phase relationship is, in effect, a type of Doppler shift which depends on bearing angle (in azimuth).

The high-resolution picture is obtained by correlating all the sample return signals for each ground target in a coherent manner, i.e., integrating them together, taking into consideration their time-phase relationships. The use of multiple sample returns from each target enables a high azimuth resolution to be obtained which is equivalent to that obtained by a long synthetic aperture. For each target, the length of the synthetic aperture is equivalent to the distance flown during the time when all the radar samples are being taken from the target. In general, the more samples that are taken from a target, the higher will be the resolution. The correlation process can be done either optically or electronically, but in this experiment it is recommended that electronic correlation be used, especially since optical processing requires photographic film processing, and this ought to be avoided if possible in space applications.

- c. Growth Potential: Side-looking radar surveillance of a planetary surface from a satellite offers great potential usefulness for future surveillance programs, especially of a planet like Venus, because radar can penetrate cloud cover and can operate under both day and night conditions. No other sensors can match radar from the all-weather standpoint. Although the side-looking radar in this experiment will be used to survey the earth's surface, its parameters have been chosen to be suitable for performing surveillance of other planetary surfaces as well, particularly that of Venus.

### 3.2 MEASUREMENTS AND DATA:

- a. Phenomena to be Observed: Continuous radar surveillance of a strip of the Earth's surface on one side of the satellite's flight path. The strip will be at least 50 kilometers wide and can be as long as desired. Radar images will be obtained of many different types of terrain, including farm lands, mountains, deserts, and

MI-3  
(Sheet 3)

populated areas. Images will be obtained both day and night and with various types of weather conditions, including clouds and rain.

- b. Resolution: The final radar image, after data processing, will have a ground resolution of 30 meters in both range and azimuth (for an attitude of 185 kilometers).
- c. Measurement rate: Continuous.
- d. Frequency: Possible radar frequencies which can be used are L-band (about 1 gigacycle per second), S-band (about 3 gigacycles per second), or X-band (about 9 gigacycles per second). In this experiment, it is assumed that L-band will be utilized on account of its superior cloud penetration capability. An L-band radar has an excellent future potential for surveying the surface of Venus through its thick cloud cover.
- e. Antenna Pointing Accuracy: Provisions must be included for insuring that the antenna remains parallel to the effective ground track during operation. This must be accomplished to within  $\pm 0.1$  degree. If this cannot be done, it will be necessary to add a clutter-lock capability to the radar to compensate for the lack of parallel alignment.

3.3 FLIGHT REGIME:

- a. Orbital Parameters: It is assumed that the orbit altitude will be 370 kilometers or less. However, higher orbit altitudes can be used provided that the radar power is increased. Orbit inclination is not critical.
- b. In-Flight Duration: Not critical.
- c. Seasonal and Diurnal Requirements: Not critical.

3.4 SUPPORT EXPERIMENTATION: There is no requirement for supporting Earth/space observations or activities.



4. OPERATIONS:

4.1 DUTY CYCLE: The recording bandwidth for the final radar image, after data processing, is about 1 megacycle per second. This data can be transmitted back to a ground station only when the vehicle is within line-of-sight of the ground station, unless a relay communications satellite is used. Assuming that a relay communications satellite is not used, it can be seen that the radar images can be collected faster than they can be transmitted back to ground stations. Therefore, on an average basis, it will be necessary to limit the radar operation to about one hour per day.

4.2 CREW REQUIREMENTS: Astronaut participation not required.

5. APPARATUS DESCRIPTION:

5.1 METHODS OF MEASUREMENT AND SENSOR DESCRIPTION: The side-looking radar is a high-resolution coherent data processing type radar. Its chief characteristics are as follows:

- a. Ground Coverage: The radar will cover a continuous swath on one side of the flight path. The sweep range is about 50 kilometers at 185 kilometers altitude, and is correspondingly greater at higher altitudes. Vertical beam width is 0.25 radian (about 15 degrees). Depression angle of the near-side of the beam is 80 degrees.
- b. Frequency: The radar will operate on L-band with a frequency of about 1.0 gigacycle per second.
- c. Ground Resolution: 30 meters in both range and azimuth at an altitude of 185 kilometers, correspondingly greater at higher altitudes.
- d. Antenna Size: The horizontal antenna dimension is 6 meters (about 20 feet); this dimension is aligned parallel to the ground track. The vertical antenna dimension depends on the wave length; for L-band it is 1.5 meters (about 5 feet).

MI-3  
(Sheet 5)

(The vertical dimension would be about 0.5 meter for S-band and about 0.2 meter for X-band).

- e. Equipment Size and Weight: Estimated as follows:

	<u>Volume(ft<sup>3</sup>)</u>	<u>Weight(lb.)</u>
Antenna	---	100
Transmitter	1.8	80
Receiver	1.0	30
Distribution & control	0.8	35
Data Processor	3.0	150
Waveguide or Coax	<u>---</u>	<u>10</u>
TOTAL	6.6	405

- f. Equipment power: Based on an altitude of 370 kilometers, the radar must provide about 200 watts average output power. The estimated input power requirements are as follows: transmitter 650 watts, receiver 150 watts, distribution and control 150 watts, and data processor 750 watts--for a total of 1700 watts.
- g. Environmental Considerations: It will probably be necessary to pressurize the waveguides. Temperature is not critical. Vibration must be minimized.
- h. Antenna Pointing Accuracy: The antenna must be stabilized so that it is aligned parallel to the effective ground track to within  $\pm 0.1$  degree. The direction of the effective ground track is defined by the resultant of two vectors, one being the velocity of the satellite in its orbital plane and the other being the eastward velocity of the earth as it turns on its axis. The direction of the effective ground track varies with earth latitude, and will be computed by an on-board navigation system. The radar will probably include a clutter-lock capability to compensate for small errors in the antenna alignment.

MI-3  
(Sheet 6)

- i. Recording: After the radar image has been correlated by the data processor, it will be recorded on video tape for subsequent transmittal back to a ground station. Auxiliary data and fiducial timing marks will be recorded to enable the photo interpreter to determine the geographical position and orientation of objects seen in the radar photograph.
- j. Development Status: Nonexistent. A fairly expensive development program will be required to develop a side-looking radar with all the capability described for this experiment. However, such a radar is feasible within the state-of-the-art, and can be built using existing techniques.
- k. Reliability: Unknown. A MTBF of 500 hours can probably be achieved in a reasonable development program.

5.2 DATA COLLECTION:

- a. Data recording: The final radar image will be recorded on magnetic tape as an analog video signal having a bandwidth of about 1 megacycle per second. (See requirements under Duty Cycle, paragraph 4.1).
- b. Data Quantity: One hour of recording per day.
- c. Auxiliary Data Recording: Navigational data and fiducial timing marks will be recorded to facilitate ground data reduction of the radar images.
- d. Data Recovery: Physical recovery is not required since the images will be telemetered back to a ground station. However, physical recovery of the recorded data and radar images can be accomplished, if desired.

5.3 ANCILLARY EQUIPMENT

MI-3  
(Sheet 7)

- a. Attitude Control Equipment: for controlling and maintaining the antenna alignment parallel with the effective ground track.
  - b. Data Recording Equipment: for recording the radar images on magnetic tape.
  - c. Data Link to Ground Station: for transmitting the radar images back to a ground station.
  - d. Programmer: For turning radar on and off.
6. CONCEPTUAL DESIGN: See Figure A.3-3.

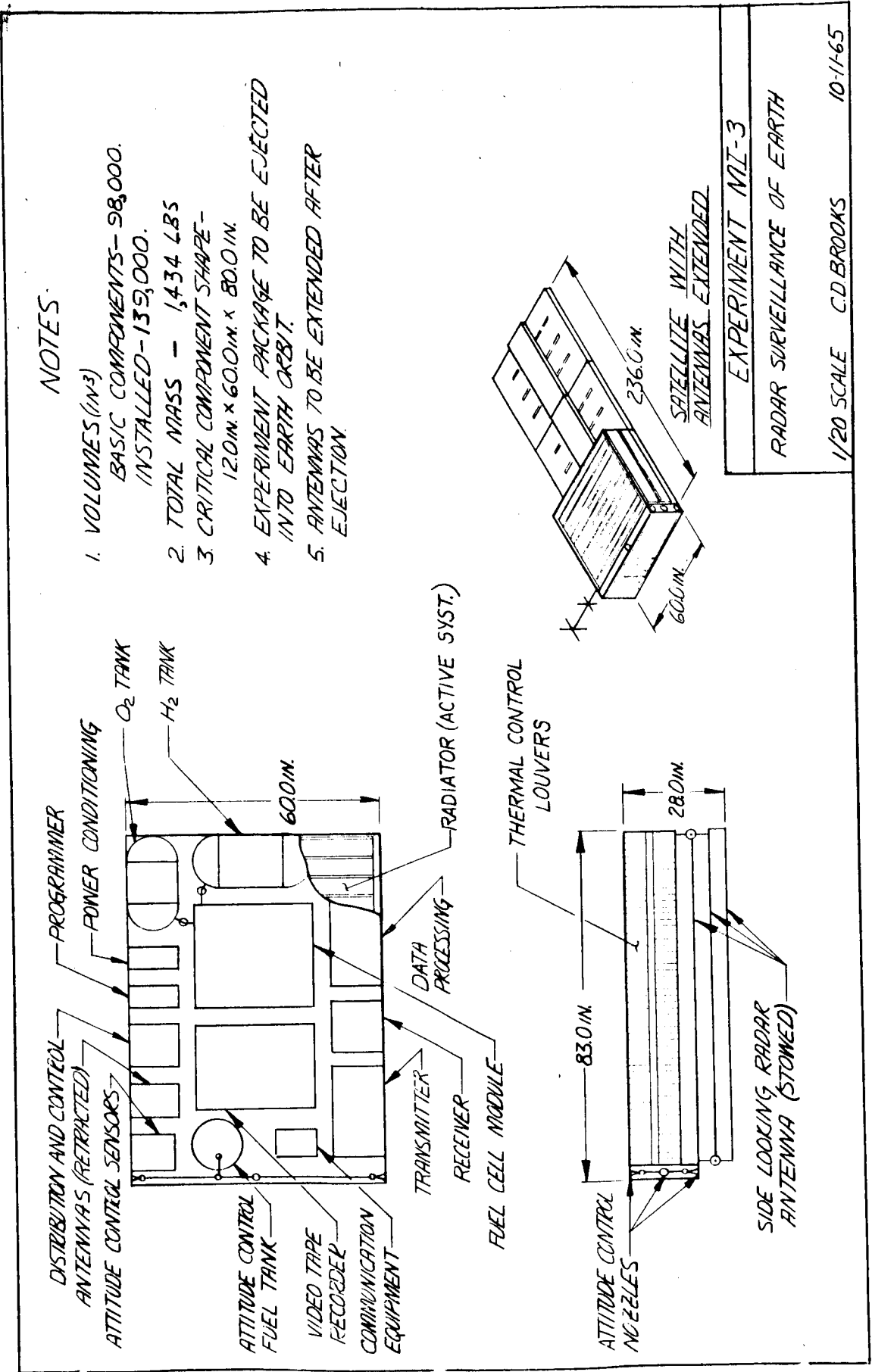

Figure A. 3-3 MI-3 CONCEPTUAL DESIGN DRAWING

1. EXPERIMENT MI-4: Electronic Image Motion Stabilization System for Earth Surveillance and Satellite Tracking.
2. TECHNICAL AREA/APPLICATIONS:
  - 2.1 GENERAL AREA: Multispectral Imagery of the Earth and Orbiting Objects
  - 2.2 EXPERIMENT APPLICATIONS: To obtain high-resolution imagery of either (1) selected areas of the Earth's surface or (2) satellite vehicles which may be in the vicinity of the experimental vehicle. The primary sensor is an electronic image tube camera which has an electronic image motion stabilization capability based on the use of optical feedback. This capability enables the camera to obtain high-resolution images of slow- or fast-moving objects because of the accurate compensation of all image motions. It also permits the use of relatively long-exposure intervals, and this in turn enables high-quality images to be obtained under relatively low-light-level conditions.
3. EXPERIMENT OBJECTIVES AND SCOPE:
  - 3.1 OBJECTIVES:
    - a. Specific Objectives: The primary objectives are:
      - (1) To obtain high-resolution imagery of selected areas of the Earth's surface under daytime illumination conditions.
      - (2) To investigate the capability of obtaining high-quality imagery of selected areas of the Earth's surface under various low-light-level conditions, including twilight and bright moonlight conditions.
      - (3) To obtain high-resolution imagery of any satellite vehicles which may happen to be in the vicinity of the experimental vehicle. This may be done in conjunction with rendezvous experiments or in conjunction with American or other satellites which may be passing by.

- b. Key Techniques: The electronic image motion stabilization technique has recently been developed by Itek Corporation. It is a highly effective method for preventing the degradation of optical images when relative angular motion exists between the object and the viewing instrument. The technique makes use of a special electron image tube camera with optical feedback. The front end of the camera consists of an optical telescope which focuses the optical image on the front face of the image tube. The image tube converts the optical image to an electron stream which is focused by deflection coils onto the tube's phosphor screen, appearing again as an optical image. The position of the image with respect to the center of the screen is sensed by a quadruple-cell sensor, whose error signal outputs are fed back to the deflection coils of the image tube to keep the image stable on the phosphor screen at all times, regardless of the motions and perturbations of the image at the front face of the tube.

### 3.2 MEASUREMENTS AND DATA:

- a. Targets: Two types of objects will be observed:
- (1) Selected areas of the Earth's surface, such as farm lands, cities, industrial complexes; this will be done under various illumination conditions, including bright daylight, twilight and bright moonlight.
  - (2) Orbiting satellite vehicles, illuminated by sunlight.
- b. Measurement Requirements:
- (1) Resolution: The resolution on the phosphor screen of the image tube must be equivalent to at least 400 TV lines per inch, including the effects of a Kell factor if a line scan raster is used for readout and recording. With a focal length of 2.0 meters, this is equivalent to a resolution of 12.7 arc seconds per optical line pair. At an altitude of 185 kilometers, the ground resolution will be about 12 meters per line pair (40 feet).

- (2) Field of View: About 0.71 x 0.71 degrees.
- (3) Cycling Rate: The exposure time for each frame will depend on illumination conditions, but in most cases it will be 0.25 second or longer. Continuous ground coverage can be obtained at cycling rates of about 2 frames per second. A similar rate will be used for observing satellite vehicles.
- (4) Pointing Accuracy: A wielding mirror or prism will be installed in front of the camera telescope to enable the line of sight to be pointed in any desired direction within a cone of about  $\pm 45$  degrees with respect to a normal from the vehicle. The pointing accuracy must be sufficient to get the object within the central portion of the field of view, and therefore must be accurate to within about  $\pm 0.2$  degree. For observation of objects on the Earth's surface, the pointing will be done in accordance with command signals either from a ground station or from an on-board programmer. For observation of satellite vehicles, a different pointing mode is necessary; in this case, an auxiliary infrared or radar finder/tracker will be used to search, find, and track the satellite vehicle. Signals from the finder/tracker will control the line-of-sight of the telescope camera to an accuracy within  $\pm 0.2$  degree. The search field of the finder/tracker will be about  $\pm 45$  degrees.

### 3.3 FLIGHT REGIME:

- a. Earth Observation: For observation of objects on the Earth's surface, altitudes of less than 370 kilometers are desired. The orbital inclination and the in-flight duration of the experiment are not critical. At least some of the observations of the Earth's surface should be performed under bright moonlight conditions.



- b. **Satellite Vehicle Observation:** If possible, the viewing distance to the satellite vehicle should be between 10 and 50 kilometers, although greater distances can also be used with some degradation of detail in the image due to insufficient focal length. The relative angular motion of the satellite vehicle with respect to the telescope camera should be minimized, if possible, to less than 0.25 radian per second. To achieve these conditions it will be necessary to select an appropriate launch time and an appropriate orbital altitude and inclination to intercept the satellite vehicle. It may also be necessary to do some maneuvering in space to optimize the viewing conditions.

#### 3.4 SUPPORT EXPERIMENTATION:

- a. **Simultaneous Activities:** Observation of a satellite vehicle requires synchronization of the experiment with the orbital passage of the satellite vehicle. This may be done in conjunction with rendezvous experiments or with other satellite vehicles.
- b. **Prerequisite experimentation:** None.

#### 4. OPERATIONS:

- 4.1 **DUTY CYCLE:** Each observational period will consist of a series of pictures taken at a rate of about 2 frames per second for a period of about 10 to 30 seconds. It is unlikely that more than one or two satellite observations will take place on a given flight. On the other hand, many observations of ground objects can take place on a given flight. For planning purposes, it is assumed that 50 observations per day, each averaging 20 seconds, will be taken of various ground objects with various illuminations condition, ranging from bright daylight to bright moonlight.
- 4.2 **CREW REQUIREMENTS:** Astronaut participation is not required. It is assumed that the pictures are recorded on magnetic tape and telemetered back to

ground stations. However, if a decision were made to record the pictures on photographic film instead of magnetic tape, an astronaut could be used to recover the film and return it in the Command Module.

## 5. APPARATUS DESCRIPTION:

5.1 METHODS OF MEASUREMENT AND SENSOR DESCRIPTION: The primary sensing equipment consists of a telescope camera, a welding mirror assembly, and an auxiliary finder/tracker.

a. Telescope Camera: The telescope camera is a special type camera with an electronic image motion stabilization capability based on optical feedback. The key element in the camera is a special electron image tube. The front end of the camera consists of an optical telescope which focuses the optical image onto the front face of the image tube. The image tube converts the optical image to an electron stream which is focused by deflection coils onto the tube's phosphor screen, to appear again as an optical image. The position of the image with respect to the center of the screen is sensed by a quadruple-cell sensor (four multiplier phototubes arranged in quadrature), and the error signal outputs from the quadruple-cell sensor are fed back to the deflection coils of the image tube to keep the image stable on the phosphor screen at all times, regardless of the motions and perturbations of the image at the front face of the tube. This technique has been developed and demonstrated by Itek Corporation.

The general characteristics of the telescope camera are as follows:

- (1) Telescope optics: Almost any conventional telescope design can be used. However, the following characteristics are recommended: Maksutov Cassegrain folded configuration, 2.0-meter focal length, aperture at least 25 cm (f/8), field of view of at least 0.71 x 0.71 degree, format on the front face of the image tube about 1.0 x 1.0 inches, lightweight construction.

- (2) Equipment size: The estimated size of the camera (without telescope) is 24L x 12W x 6H inches. The estimated size of the telescope is 24 inches long x 12 inches diameter. The telescope is installed in front of the camera for a total length of 48 inches. In addition, a welding mirror assembly is installed in front of the telescope to enable the line-of-sight to be pointed in any desired direction within a  $\pm 45$ -degree cone.
  - (3) Equipment weight: The estimated weight of the camera (without telescope) is 40 pounds. The estimated weight of the telescope (not including the welding mirror assembly) is 50 pounds.
  - (4) Power requirements: Estimated 200 watts for camera.
  - (5) Environmental considerations: The temperature gradient across the telescope should not exceed  $\pm 5$  degrees C. The temperature of the image tube in the camera should be maintained below 40 degrees C.
  - (6) Frequency spectrum: visible light.
  - (7) Recording: optical scan of the phosphor screen with conversion to video signal, recording on magnetic tape.
  - (8) Development status: Nonexistent, will be based on existing developmental phototypes which have been built by Itek Corporation.
  - (9) Reliability: Unknown; reliability should be similar to that of simple television equipment.
- b. Welding Mirror Assembly: This assembly consists of a movable flat mirror in a servo-controlled two-axis gimbal system, and it is installed in front of the telescope camera to enable the line of sight to be pointed in any desired direction

within a  $\pm 45$ -degree cone. The pointing accuracy must be good enough to place the desired object in the central portion of the field of view of the telescope camera; the accuracy of pointing must be within  $\pm 0.2$  degree. For observation of objects on the Earth's surface, the welding mirror will be positioned in accordance with command signals from either ground stations or from an on-board programmer. For observation of satellite vehicles, the welding mirror will be positioned in accordance with tracking command signals from the auxiliary finder/tracker. The general characteristics of the welding mirror assembly are as follows:

- (1) Search field of view:  $\pm 45$  degrees.
- (2) Tracking accuracy:  $\pm 0.2$  degrees. The welding mirror assembly provides coarse tracking, and the image motion stabilization capability of the camera provides fine tracking. The combination of both coarse and fine tracking enables relatively long exposure intervals to be used, on the order of from 0.25 to 1.0 second or longer.
- (3) Equipment size: The flat mirror is approximately 15 inches in diameter. The welding mirror assembly, including the roll and pitch gimbals, will occupy a space of about 24 x 24 x 12 inches, the exact dimensions depending on the installation configuration.
- (4) Equipment weight: The estimated weight of the welding mirror assembly, including gimbals and servo amplifiers, is 40 pounds.
- (5) Power requirements: Estimated 100 watts during operation.
- (6) Environmental considerations: Not critical. Depending on the installation configuration, it may be desirable to stow the assembly during take-off in a different configuration than during operation.

- (7) Development Status: Nonexistent. Can be built using state-of-the-art techniques.
  - (8) Reliability: Unknown. Probably fairly high.
- c. Auxiliary Finder/Tracker: This device is not needed for observation of objects on the ground, but it is needed for observation of satellite vehicles. Its purpose is to search, acquire, and track the satellite vehicle when it is in the vicinity, and to provide tracking command signals to the welding mirror assembly so that the image of the satellite vehicle can be picked up by the telescope camera. The finder/tracker can be either an infrared or a radar type device, but it is assumed that an infrared type device will be used since it is capable of a higher angular pointing accuracy. The general characteristics of the auxiliary finder/tracker are as follows:
- (1) Search field of view:  $\pm 45$ -degree cone.
  - (2) Modes of operation: Search mode and track mode. The device will be capable of discriminating nearby satellite vehicles from the star background.
  - (3) Tracking accuracy:  $\pm 0.2$  degree or better.
  - (4) Equipment size: Estimated 12 x 12 x 12 inches.
  - (5) Equipment weight: Estimated 25 pounds.
  - (6) Power requirements: Estimated 75 watts.
  - (7) Environmental considerations: Closed-cycle cooling is probably required for the infrared detector.
  - (8) Frequency spectrum: Infrared wavelength of from 1 to 5 microns.
  - (9) Development status: Nonexistent. Can be developed with existing state-of-the-art techniques.

(10) Reliability: Unknown.

5.2 DATA COLLECTION:

- a. Data Recording: For each frame, the optical image on the phosphor screen of the image tube will be read-out by a line scan raster technique, and converted to a video signal. The video signal will be recorded on magnetic tape and then transmitted to a ground station at a later time. If analog video recording is done at a rate of 0.125 second per frame, a recording bandwidth of about 1.2 megacycles per second will be required. Telemetering to the ground will be done at a slower rate, with a bandwidth of about 0.4 megacycle per second.
- b. Data Quantity: A nominal mission will collect a total of 2,000 frames per day. These will be obtained in short bursts of about 40 frames each, with an average cycling rate of 2 frames per second.
- c. Photographic Recording: Photographic recording of the images on the phosphor screen is not planned, but could be easily added, if desired. In this case, physical recovery of the film would be required.
- d. Auxiliary Data Recording: Navigational data, pointing data, and time (to the nearest 0.1 second) must be recorded simultaneously with each frame to enable the photo interpreter to determine the position and orientation of the objects in each picture. This data may be recorded on magnetic tape.

5.3 ANCILLARY EQUIPMENT:

- a. Magnetic Tape Recorder: For recording the video images collected by the telescope camera. An analog recording bandwidth of 1.2 megacycles per second is required.

MI-4  
(Sheet 10)

- b. Telemetering Data Link: For transmitting the video images to one or more ground stations. The video signals will be readout from the video tape, and transmitted to ground stations at convenient times. Transmission can be done at any convenient rate, but it is suggested that a bandwidth of about 400 kilocycles per second be used.
- c. Programmer: This device may be needed to turn the equipment on and off at the correct times and to point the line of sight towards pre-selected target areas on the ground. However, the functions of programming can be done by ground stations, if desired, instead of by an on-board programmer.

6. CONCEPTUAL DESIGN: See Figure A.3-4.

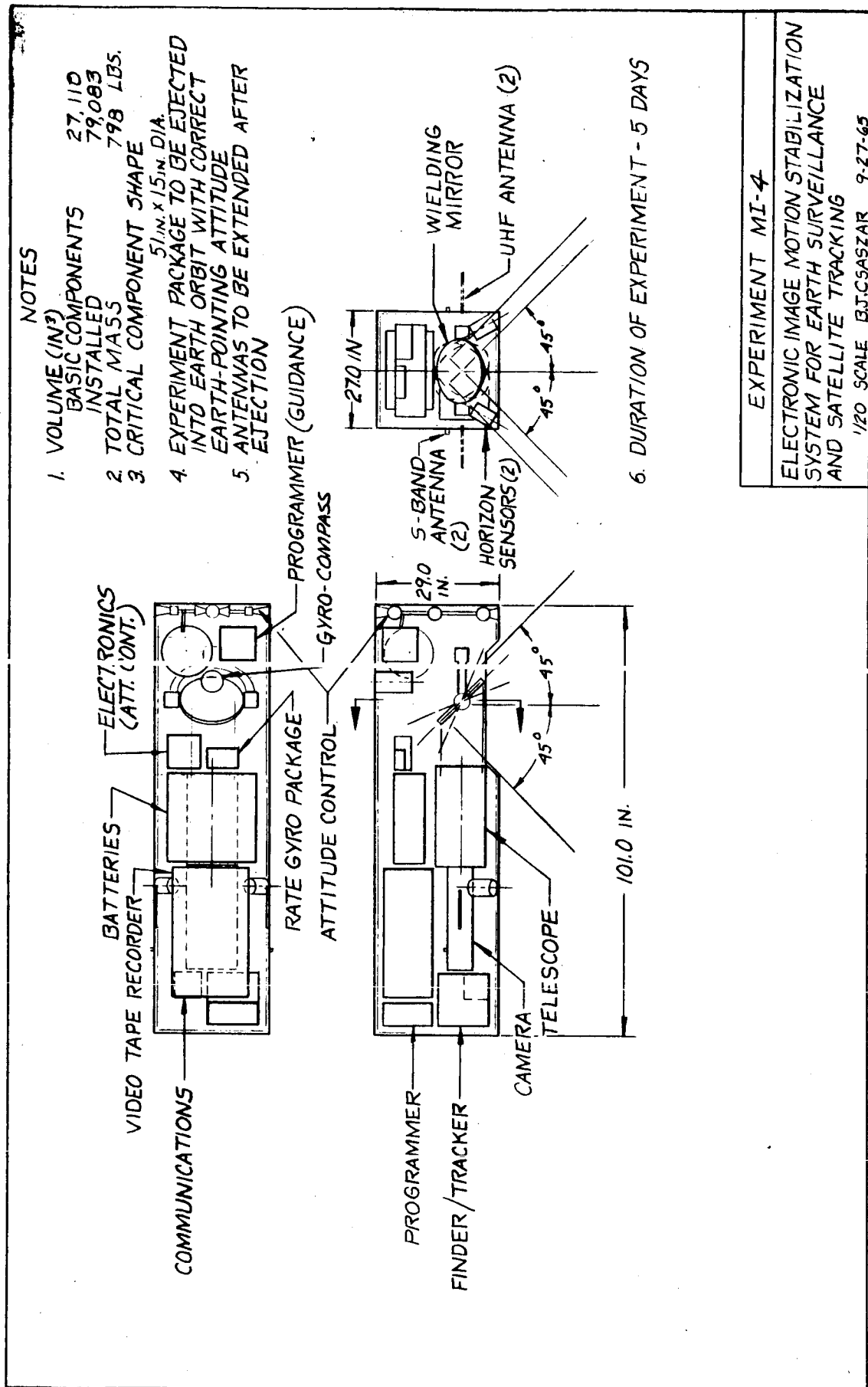

Figure A.3-4 MI-4 CONCEPTUAL DESIGN DRAWING



1. EXPERIMENT MI-5: Synoptic Earth Cartography

2. TECHNICAL AREA/APPLICATIONS:

2.1 GENERAL AREA: Multispectral Imagery of the Earth and Orbiting Objects

2.2 EXPERIMENT APPLICATIONS: To obtain wide-area stereo photography of cartographic quality of selected Earth areas. Photo processing and cartographic data reduction will be accomplished on the ground.

3. EXPERIMENT OBJECTIVES AND SCOPE:

3.1 OBJECTIVES:

a. Specific Objectives:

- (1) Develop and test a satellite-borne cartographic system for obtaining wide-area stereo photography.
- (2) Obtain a complete set of overlapping stereo photography of selected Earth areas. Large geographic areas will be covered, consisting of one or more of the major continents.
- (3) Develop and test a ground data reduction capability by making an accurate map from the photographs collected in orbit. The map will be as accurate as possible and will include elevation contours obtained by stereo techniques. Modern computer techniques will be used for adjusting the data for a best fit.

b. Key Techniques:

- (1) The satellite system will be based on modifications of existing aerial mapping techniques. Stereo photography will be used for determination of elevation contours. The cameras will be designed specifically to meet the geometric accuracy requirements of modern cartography.

(2) The ground cartographic data reduction system will employ modern analytic techniques using a large digital computer for adjusting the data.

c. Growth Potential: In addition to mapping continental areas of the Earth, the system will have potential usefulness for mapping other planetary surfaces, such as Mars or the Moon.

### 3.2 MEASUREMENTS AND DATA

- a. Data to be Observed: The primary data will be a set of aerial photographs covering one or more continental areas of the Earth's surface. These photographs will overlap by about 60 percent in the forward direction in order to provide a stereo capability. These photographs will also overlap to some extent in the transverse direction; this is achieved by photographing the area on several orbit passes. Photography will be obtained only during the day time.
- b. Auxiliary Data: Auxiliary data is required for each photograph to facilitate the ground data reduction process and to enable the photo cartographer to determine the geographic location and orientation of each photograph.

The auxiliary data includes the following:

- (1) Navigational data (orbit ephemeris)
  - (2) Pointing data of camera group
  - (3) Time (recorded to nearest 0.01 second)
  - (4) Lens and camera calibration data (such as distortion curves, fiducial marks, and geometric reseau).
- c. Specific Data Requirements: Several types of cartographic systems are possible, depending on various trade-offs between ground coverage

and ground resolution (i.e., between field of view and focal length). Based on a middle-of-the-road approach, the following characteristics are recommended:

- (1) Horizontal ground resolution: about 15 meters
- (2) Vertical ground resolution: about 25 meters as viewed on a stereo plotter with a stereo base/height ratio of 0.3.
- (3) Multicamera configuration: Three frame cameras, installed as a vertical camera and left and right side oblique cameras.
- (4) Format: 9 x 9 inches, each camera.
- (5) Focal length: 12 inches, each camera.
- (6) Field of View: 41 x 41 degrees, each camera. The two side oblique cameras are each installed at 35 degrees from the vertical. The three-camera fan provides a transverse field of view of ± 55.5 degrees.
- (7) Cycling rate: Each camera operates at a rate to provide 60-percent forward overlap; this rate is about 8 seconds per frame.
- (8) Ground Coverage: For planning purposes, it is assumed that each of the three cameras will contain one roll of film 9.5 inches wide by 5500 feet long. At an altitude of 200 kilometers this amount of film will provide a total ground coverage equal to 83 photo runs, each averaging 5000 kilometers long by 580 kilometers wide. This amount is enough to repeat the coverage of any major continent several times.

- (9) Pointing Accuracy: Verticality of the vertical camera should be maintained to within 0.25 degree RMS.
- (10) Image Motion Compensation: Each of the cameras require image motion compensation of the moving-film type. Based on a nominal shutter speed of 0.01 second, the IMC rate must be accurate to within  $\pm 5$  percent. Alignment of the film transport with respect to ground track must be accurate to within  $\pm 2.5$  degrees. The IMC control signals will be based on a V/H signal either from the navigation system or from an auxiliary V/H sensor.

### 3.3 FLIGHT REGIME:

- a. Orbital Parameters: A near-circular orbit is desired with an altitude of about 200 kilometers. Coverage of the major continents implies that the inclination must be at least 70 degrees. For each cartographic mission, it will be necessary to choose an altitude, inclination and launch time to provide the most efficient coverage of the selected geographic area during day time illumination conditions.
- b. In-Flight Duration of Experiment: Depending on weather conditions and the orbital period, the experiment will require an in-flight duration of 20 to 40 days.
- c. Seasonal or Diurnal Requirements: Daytime illumination is necessary for aerial photography. Adequate illumination occurs when the sun angle is more than 30 degrees above the horizontal. A retrograde inclination of about 83 degrees would enable the experimental satellite to be synchronized with a constant daytime illumination condition, and would therefore be an excellent choice for the cartographic mission. However, other inclinations may also be used, but greater care must be taken to insure adequate daytime coverage of the target area.

3.4 SUPPORT EXPERIMENTATION:

- a. Simultaneous Earth/Space Activities: An accurate orbit ephemeris is essential for cartographic purposes. A network by ground transponders, such as SECOR or AROD, is recommended to determine the position of the satellite as accurately as possible.
- b. Prerequisite Earth/Space Activities: None.

4. OPERATIONS:

- 4.1 DUTY CYCLE: The aerial cameras will be operated only when they are over the continental target area during suitable daytime illumination conditions. Furthermore, they will not operate if the area is covered by heavy cloud cover. On an average, the cameras will make about 5 photo runs per day, each about 11 minutes long (equivalent to 5000 kilometers ground cover per photo run). The interval between successive photo runs will be at least one hour.
- 4.2 CREW REQUIREMENTS: Astronaut participation is not required. The photographic film will be automatically wound up into a suitable reentry capsule for return to Earth. Command signals for turning the cameras on or off will be furnished either from an on-board programmer or from ground stations.

5. APPARATUS DESCRIPTION:

5.1 METHODS OF MEASUREMENT AND SENSOR DESCRIPTION:

The cartographic camera group consists of three identical frame cameras installed in traverse fan. One camera is vertical and the other two are left and side oblique, each at an angle of 35 degrees from the vertical. In principle, this configuration resembles the conventional "tri-metrogon" installation which has been used for many years. Each camera contains one roll of film which is wound up into a reentry capsule for return to Earth. The principal characteristics of the camera group are as follows:

MI-5  
(Sheet 6)

- a. Focal Length: 12 inches
- b. Format: 9 x 9 inches per frame
- c. Resolution: 50 line pairs per millimeter, equivalent to 13.7 arc seconds. At an altitude of 200 kilometers this provides a ground resolution of 13.4 meters in the vertical photographs.
- d. Field of View: Each camera has a field of view of 41 x 41 degrees. The three-camera fan provides a swath width of  $\pm$  55.5 degrees.
- e. Forward Overlap: 60%. This provides a stereo base/height ratio of 0.3.
- f. Film Quantity: Each of the three cameras contains one roll of thin-base film 9.5 inches wide by 5500 feet long. This film is exposed at a rate of about 13.2 feet of film per 1000 kilometers of ground travel. Each roll of film weighs about 110 pounds (including spool) and occupies a 17-inch diameter.
- g. Equipment Size: Each camera consists of a camera body plus a camera magazine. The size of the camera body is 18W x 18L x 15H inches. The shape of the camera magazine depends on the method used for winding the exposed film into the reentry capsule. The camera magazine adds several inches to the height of the camera and must be large enough to accommodate a roll of film 9.5 inches wide by 17 inches in diameter.
- h. Equipment Weight: The estimated weight of each camera (including camera body and magazine, but not including film) is 125 pounds. A camera control box weighs about 30 pounds. The total weight of the system is:

<u>System</u>	<u>Weight(lb)</u>
3 cameras	375
3 rolls of film	330
1 camera control box	<u>30</u>
TOTAL	735

- i. Electrical Power Requirements: estimated at 600 watts for the total system during operation.
- j. Environmental Considerations: The chief environmental requirements are concerned with handling the photographic film. If possible, the film should be kept in a pressurized condition with a relative humidity between 25 and 75 per cent; this prevents the film from losing its moisture content. When film dries out, it becomes brittle, and film transport becomes difficult. Film flattening at the platen is another problem which must be considered. The conventional solution is to use a partial vacuum differential to hold the film against the platen during exposure. However, in a zero-g environment it may be sufficient to hold the film flat by mechanical tension on the film. It is also necessary to consider radiation protection of the film against solar flares and other radiation in space. Partial shielding may be a satisfactory answer. Another possible technique may be to lower the temperature of the film during long term storage. The sensitivity of the photographic emulsion to radiation and visible light becomes very low at reduced temperatures. However, it would be necessary to raise the temperature to about 10 to 30 degrees centigrade prior to exposure in order to restore the photographic sensitivity. The chief environmental requirement for the optical system is to minimize vibration.
- k. Special Camera Features: image motion compensation, automatic exposure control, auxiliary data recording on each frame, accurate fiducial marks, and a special cartographic reseau (fiducial grid marks throughout the frame).

1. Pointing Accuracy: Verticality of vertical camera to within 0.25 degree RMS. Alignment of film transport IMC with ground track to within  $\pm 2.5$  degrees.
- m. Development Status: The specific cameras described above are nonexistent. However, except for the 12-inch lens, they are similar to existing cartographic cameras, such as the KC-6A or the KC-1. A new 12-inch cartographic lens must be developed for the cameras.
- n. Ground Data Reduction: The cartographic data reduction techniques will be similar, in principle, to existing cartographic techniques used by various agencies, such as the Army Map Service, the Air Force Aeronautical Chart and Information Center, or the Coast and Geodetic Survey. The ground data reduction requirements must be definitized as early in the program as possible in order to insure a complete cartographic capability.
- o. Reliability: Unknown. Probably very high.

#### 5.2 DATA COLLECTION:

- a. Format: Overlapping photography. Each frame is 9 x 9 inches.
- b. Bulk of Data: Total data bulk is three rolls of film, each 9.5 inches wide by 5500 feet long. (See Duty Cycle requirements, paragraph 4.1.)
- c. Data Recovery: The data bulk is too large to return by telemetry. It is therefore necessary to return the film physically in a reentry capsule. A total of 330 pounds of film must be returned.

#### 5.3 ANCILLARY EQUIPMENT:

- a. Auxiliary Data Recording: navigational data, pointing data, and time (to the nearest 0.01 second) must be recorded. This data can be recorded on magnetic tape (which returns in the



reentry capsule), but significant amounts of this data must also be recorded between frames on the photographic film.

- b. V/H Signals: This data controls the image motion compensation of the cameras. It comes either from the navigation system or from an auxiliary V/H sensor.
- c. Programmer: An on-board programmer is recommended to turn the cameras on and off at the correct times.
- d. Telemetry: This is required if ground station commands are used in the cartographic operation.

6. CONCEPTUAL DESIGN: See Figure A.3-5.

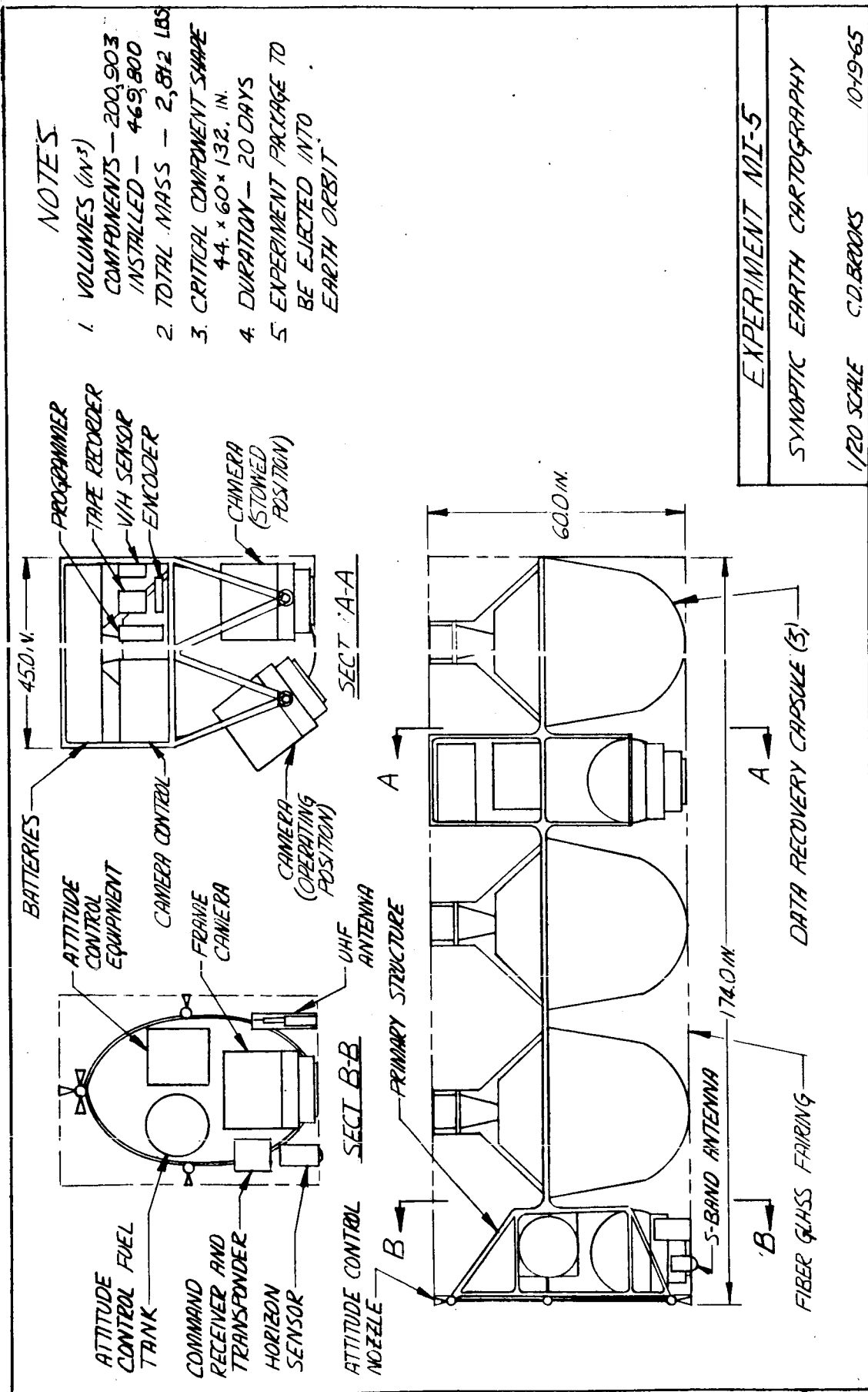

Figure A. 3-5 MI-5 CONCEPTUAL DESIGN DRAWING

CATEGORY IV - SOLID/LIQUID/GAS BEHAVIOR (SLG)

The experiments in Category IV provide information on the behavior of solid/liquid/gas mixtures in a zero-gravity environment. The five experiments in this category are designated as follows:

SLG-1: Boiling in Zero-Gravity Environment

SLG-2: Nucleate Condensation in Zero-Gravity

SLG-3: Formation of Single Crystals

SLG-4: Segregation of Immiscible Liquids Under Zero-Gravity Conditions

SLG-5: Zero-Gravity Combustion.

A conceptual design drawing for each of the 5 experiments is presented on the last page of each experiment description. In many cases, illustrations and tabular data relating to the experiment are included in the final pages of the description.

1. EXPERIMENT SLG-1: Boiling in Zero-g Environment
2. TECHNICAL AREA/APPLICATIONS:
  - 2.1 GENERAL AREA: Solid/Liquid/Gas Behavior
  - 2.2 EXPERIMENT APPLICATIONS: To understand heat transfer in the absence of buoyant forces.
3. EXPERIMENT OBJECTIVES AND SCOPE:
  - 3.1 OBJECTIVES:
    - a. Specific Objective: To measure heat transfer rates from a solid heater to a liquid-vapor mixture, and to study the details of the heat transfer mechanism.
    - b. Key Techniques: A liquid vapor mixture contained in a closed chamber will be heated by an electrical resistance heater. The heat flux will be varied by regulation of the current to the heater and temperatures of the liquid and the heater and pressures will be recorded. High-speed movies will be made so that bubble dynamics can be analyzed.
  - 3.2 MEASUREMENTS AND DATA:
    - a. Phenomena to be Observed: The pressure in the cell, the temperature of the fluid at three points, and the temperature of the heater are to be recorded. High-speed movies during boiling at various heat fluxes are required. The power consumed by the heater must be recorded.
    - b. Measurement Rate, Accuracy: All temperatures should be measured to  $\pm 1^{\circ}\text{K}$  in the range of  $280^{\circ}\text{K}$  to  $400^{\circ}\text{K}$ . The pressure should be measured to  $\pm 2\%$  in the range of 5 psi to 200 psi. The power to the heater should be known to  $\pm 2\%$  in the range from 0 to 50 watts. The camera should record images of bubbles as small as 1 mm and have a framing rate of about 10,000 frames per second and make 10 frames in a series.

SLG-1  
(Sheet 2)

3.3 FLIGHT REGIME:

- a. Orbital Parameters: Any orbit.
- b. Duration: Two hours.
- c. Seasonal Requirements: None
- d. Other Flight Characteristics: g less than  $10^{-4}$  g.
- e. Reasons: The object of the experiment is to study boiling under condition d.

3.4 SUPPORT EXPERIMENTATION:

- a. Simultaneous Activities: None
- b. Prerequisite Experimentation: The equipment must be checked on the ground.

4. OPERATIONS

4.1 DUTY CYCLE:

- a. Operational Periods: One operational cycle of two hours.
- b. Interval: Not applicable.

4.2 CREW REQUIREMENTS:

- a. Astronaut Participation: Crew must retrieve film. If the camera is not used, the other data will be much less useful.
- b. Crew Involvement: Retrieve film from camera.

5. APPARATUS DESCRIPTION:

5.1 METHODS OF MEASUREMENT AND SENSOR DESCRIPTION:

SLG-1  
(Sheet 3)

- a. **Methods of Measurement:** Temperature can be measured with thermocouples. Pressure can be measured with strain gage transducer. Power to the heater requires a voltmeter and an ammeter. The high-speed pictures require a framing camera with provision for automatically advancing the film.
- b. **Sensor Description:** The test cell will be about a 10-cm cube with optical windows. The cell will be partially filled with a liquid, and its vapor will occupy the rest of the cell.

5.2 DATA COLLECTION

- a. **Format:** The output from each of the sensors is a voltage which can be recorded in the most convenient of several ways. The camera, of course, records on film.
- b. **Amount:** Ten sets of ten frames of film and 1,000 temperature and pressure points will be required.
- c. **Recovery Advantages:** The photograph will contain the most valuable information because it will reveal the dynamics of bubble growth and motion.

5.3 ANCILLARY EQUIPMENT: Equipment to record or telemeter the temperatures and pressures.

6. CONCEPTUAL DESIGN: See Figure A.4-1.

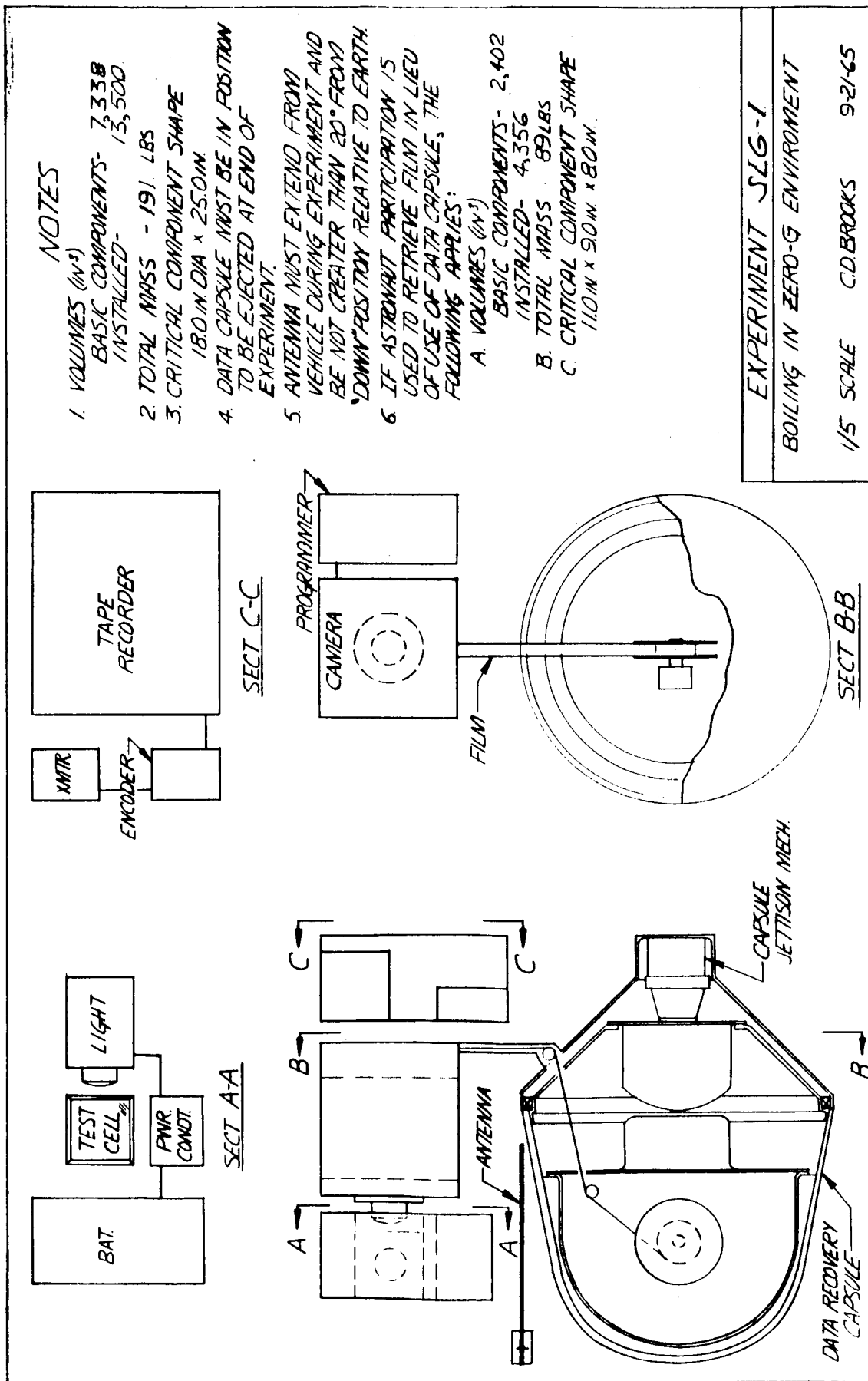

Figure A. 4-1 SLG-1 CONCEPTUAL DESIGN DRAWING

1. EXPERIMENT SLG-2: Nucleate Condensation in Zero-Gravity
2. TECHNICAL AREA/APPLICATIONS:
  - 2.1 GENERAL AREA: Solid/Liquid/Gas Behavior
  - 2.2 EXPERIMENT APPLICATIONS: To provide basic information on the problem of providing habitable environmental conditions in shirt-sleeve enclosures (e.g., manned orbiting laboratory).
3. EXPERIMENT OBJECTIVES AND SCOPE:

### 3.1 OBJECTIVES

- a. Specific Objective: The specific objectives are (1) study of the initiation conditions for condensation and (2) the concentration distribution of the resulting two-phase mixture as a function of time after initiation.

After the temperature of a fluid decreases past the saturation condition, liquid droplets begin to form. The droplets usually originate at nucleation sites provided by foreign particles or trace contaminants. In a 1-g environment, the latent heat given up during condensation induces convective currents which facilitate droplet growth. In zero-gravity, a pure material may exhibit a different condensation mechanism in the absence of convective effects and nucleation sites.

- b. Key Techniques: A pure fluid, contained in a transparent test cell with chemically clean walls, will be heated until completely vaporized. Gradual cooling will then be initiated, and the condensation process will be monitored by a light-scattering technique.

### 3.2 MEASUREMENTS AND DATA:

- a. Phenomena to be Observed: Temperature and pressure of fluid in test cell as a function of time. Output from photocells (light scattering).



- b. Measurement Rate, Accuracy: Temperature - 0.2°C  
Pressure - .1 psi (689 N/m<sup>2</sup>) Time - .1 sec

3.3 FLIGHT REGIME:

- a. Orbital Parameters: Any
- b. Duration: 24 hours
- c. Seasonal Requirements: None
- d. Other Flight Characteristics: Accelerations acting on test cell during condensation period should not exceed 0.01 g.
- e. Reasons: It is desired to observe the entire condensation process for approximately 6 fluids.

3.4 SUPPORT EXPERIMENTATION:

- a. Simultaneous Activities: Data recorded on tape shall be transmitted and monitored upon completion of experiment.
- b. Prerequisite Experimentation: Test apparatus shall be operated Earthside to provide a catalog of light-scattering signatures against which the zero-g data can be compared.

4. OPERATIONS:

4.1 DUTY CYCLE:

- a. Operational Periods: One operational period 24 hrs. in duration; data collected on tape during condensation phase only.
- b. Interval: None

4.2 CREW REQUIREMENTS:

- a. Astronaut Participation: Not essential except for initiation.
- b. Crew Involvement: Turn experiment on.

5. APPARATUS DESCRIPTION:

5.1 METHODS OF MEASUREMENT AND SENSOR DESCRIPTION:

- a. Methods of Measurement: Pressure transducers will be piezoelectric. Thermistors will monitor test cell temperature. The onset of nucleation and concentration distribution will be determined by light source/photo cell arrangement. Photo-cell output, affected by scattering, will be compared with that from preliminary experiments conducted Earthside. Cooling will be done thermoelectrically.
- b. Sensor Description: Condensation experiment apparatus
  - (1) Equipment Size Stored: 10 x 10 x 20 inches (.25 m x .25 m x .5 m)
  - (2) Equipment Size Operating: As above
  - (3) Equipment Weight: 20 lbs (approx. 10 kg)
  - (4) Power Requirements: 300 watts peak, minimum 10 watts continuous
  - (5) Environmental Considerations: About 200 watts will be expended as heat from the apparatus; environmental temperature 0°C - 100°C.
  - (6) Frequency Spectrum: N/A
  - (7) Accuracy Considerations: None
  - (8) Pointing Accuracy Considerations: None
  - (9) Development Status: All components available. Experiment apparatus requires development
  - (10) Reliability: Excellent

5.2 DATA COLLECTION:

- a. Format: Data collected periodically on magnetic tape then transmitted en masse.

SLG-2  
(Sheet 4)

b. Amount: Approx. 30 minutes of tape per orbit

c. Recovery Advantages: None

5.3 ANCILLARY EQUIPMENT:

None

6. CONCEPTUAL DESIGN: See Figure A.4-2.

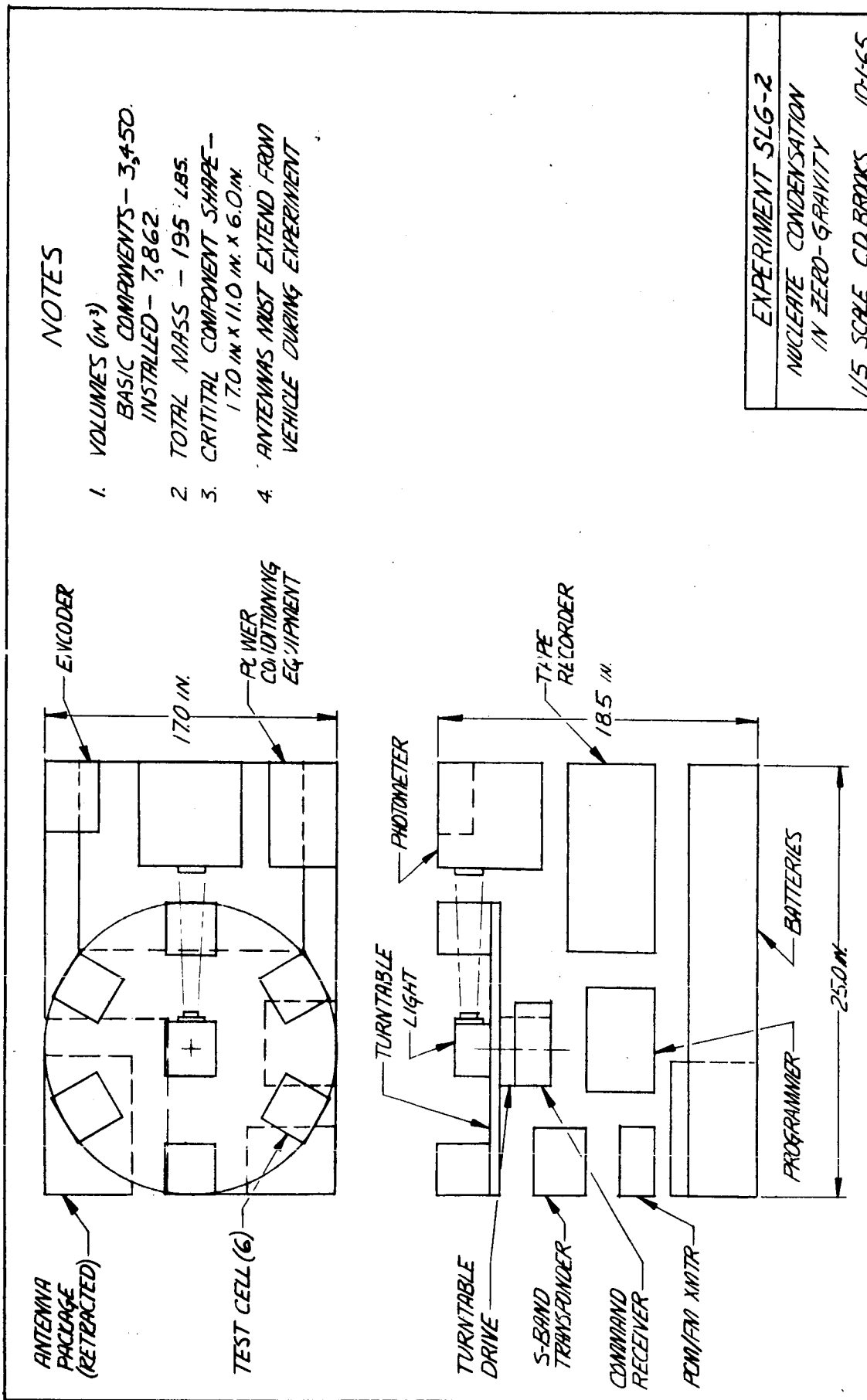

Figure A. 4-2 SLG-2 CONCEPTUAL DESIGN DRAWING

1. EXPERIMENT SLG-3: Formation of Single Crystals

2. TECHNICAL AREA/APPLICATIONS:

2.1 GENERAL AREA: Solid/Liquid/Gas Behavior

2.2 EXPERIMENT APPLICATIONS: To investigate laser crystals of higher monochromaticity: Single crystals with minimum dislocations, maximum purity, and greater size for solid-state investigations.

3. EXPERIMENT OBJECTIVES AND SCOPE:

3.1 OBJECTIVES:

- a. Specific Objective: Primary aim is to form a single crystal free from the deleterious effects of 1-g. The limitations to size of pure and near ideal single crystals of material with low surface tensions, such as H<sub>2</sub>O, organic compounds, alkali metals, etc., do not exist at zero-g. These limitations arise since the surface tension hoop stresses must balance the stresses caused by gravitational body forces. Thus in the absence of g-forces a clearer understanding of the relationship between the surface energies of the various crystalline faces and that of the liquid surface may be obtained.
- b. Key Techniques: Samples (approx. 6) of various pure materials and compounds will be melted in a solar furnace and allowed to recrystallize, i.e., the sample will be fed into the focus of a solar collector by a temperature-sensing servo. The solid samples will be returned to earth for metallographic examination, etc. Recrystallization from a floating zone and wholly molten mass will be accomplished. Data such as melting temperatures and ambient pressures will be telemetered in real or compressed time.

3.2 MEASUREMENT AND DATA:

- a. Phenomena to be Observed: Sample temperature and ambient pressure. Travel rate of floating zone.

SLG-3  
(Sheet 2)

b. Measurement Rate, Accuracy:

Temperature -  $\pm 20^{\circ}\text{C}$   
Pressure -  $\bar{1} \times 10^{-1}$  torr  
Time - 1 sec.

3.3 FLIGHT REGIME:

- a. Orbital Parameters: Orient orbit for maximum sunlit time.
- b. Duration: Minimum ten orbits.
- c. Seasonal Requirements: None
- d. Other Flight Characteristics: Accelerations acting on experiment should not exceed  $10^{-4}$  g.
- e. Reasons: Maximize time available per orbit for melting of specimens.

3.4 SUPPORT EXPERIMENTATION:

- a. Simultaneous Activities: Telemetered data may require monitoring during sunlit hours of experiment.
- b. Prerequisite Experimentation: Duplication of space experiment to provide reference crystals.

4. OPERATIONS:

4.1 DUTY CYCLE:

- a. Operational Periods: One operational period per orbit. Minimum 10 orbits.
- b. Interval: Maximum of one-half orbit.

4.2 CREW REQUIREMENTS:

- a. Astronaut Participation: Astronaut participation is essential but minimum action is required.

SLG-3  
(Sheet 3)

- b. Crew Involvement: Astronaut will activate experiment and recover samples for return to Earth. During experiment, pilot will orient experiment within required pointing accuracy.

5. APPARATUS DESCRIPTION:

5.1 METHODS OF MEASUREMENT AND SENSOR DESCRIPTION:

- a. Methods of Measurement: Melting temperatures will be measured with a photocell optical pyrometer; ambient pressures, with ionization gage, cold cathode, etc., depending on vapor pressures of chosen samples. Travel rate of molten zone will be determined from operation of sample feed servo.
- b. Sensor Description:
  - (1) Equipment Name: Single crystal experiment
  - (2) Equipment Size Stored: 1 m x 1 m x .5 m
  - (3) Equipment Size Operating: 2 m x 2 m x 2 m
  - (4) Equipment Weight: 40 kg
  - (5) Power Requirements: 500 watts peak - 50 watts continuous
  - (6) Environmental Considerations: Equipment will be erected on exterior of spacecraft; hence thermal radiation from molten specimen will require shielding. Sample will require insulation for controlled recrystallization.
  - (7) Frequency Spectrum: N/A
  - (8) Accuracy Considerations: N/A

SLG-3  
(Sheet 4)

- (9) Pointing Accuracy Considerations: Solar collector must be oriented within  $2^{\circ}$  of solar radius during a sample run.
- (10) Development Status: Solar collector development satisfactory; temperature-sensing feed servo requires development.
- (11) Reliability: Unknown

5.2 DATA COLLECTION:

- a. Format: Magnetic tape
- b. Amount: approx. 45 minutes of tape per orbit
- c. Recovery Advantages: The experiment depends almost totally on recovery intact of processed samples.

5.3 ANCILLARY EQUIPMENT:

On-board data recorder for storage and re-transmission on taped information.

Note: Pointing accuracies and duration thereof, if untenable by astronaut, would require complete separation of experiment from spacecraft. Hence, (1) a thrust system for placing experiment in desirable orbit, (2) an attitude control system, and (3) a recovery system would then become part of the experiment package.

6. CONCEPTUAL DESIGN: See Figure A.4-3.



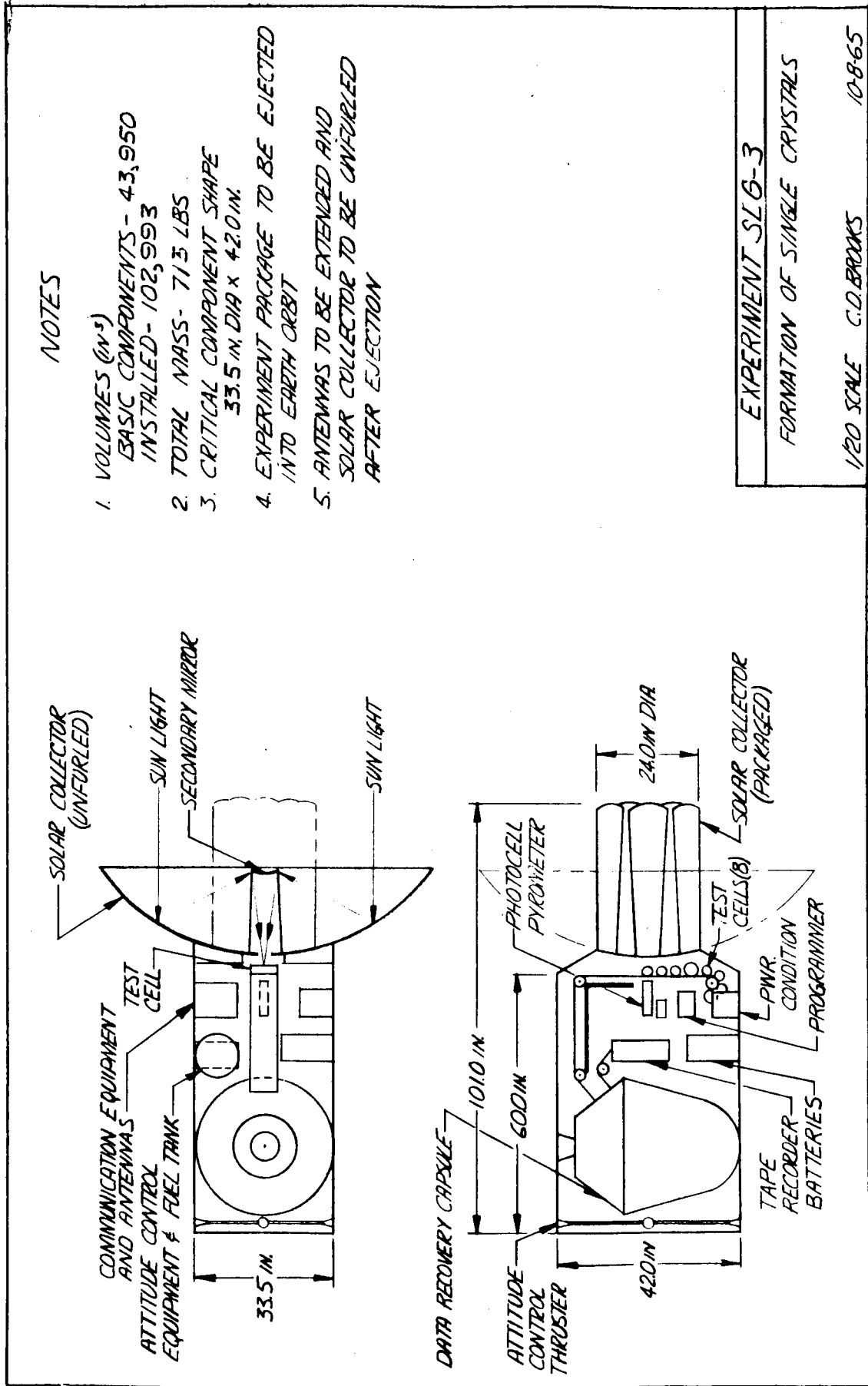

Figure A. 4-3 SLG-3 CONCEPTUAL DESIGN DRAWING

1. EXPERIMENT SLG-4: Segregation of Immiscible Liquids Under Zero-Gravity Conditions
2. TECHNICAL AREA/APPLICATIONS:
  - 2.1 GENERAL AREA: Solid/Liquid/Gas Behavior
  - 2.2 EXPERIMENT APPLICATIONS: To obtain basic information on the migration and coalescence of liquid droplets when unaided by gravity forces.
3. EXPERIMENT OBJECTIVES AND SCOPE:
  - 3.1 OBJECTIVES:
    - a. Specific Objective: To increase our understanding of surface tension effects and cohesion of liquid drops by observing the action of such forces when their influence is not masked by the dominant force of gravity. To determine the influence of liquid density and viscosity on such mechanisms.
    - b. Key Techniques: Cubic test cells containing two immiscible liquids will be vigorously agitated to produce a suspension of isolated droplets of one liquid in the other. When the agitation has produced the proper size droplets, it will be discontinued. Motion picture cameras will then be used to observe the motion of the droplets and the details of the coalescence process which takes place under the zero-gravity conditions.
  - 3.2 MEASUREMENTS AND DATA:
    - a. Phenomena to be Observed: Size distribution of suspended droplets will be determined as a function of time for each test cell. Temperature of fluid in test cell will be recorded at time of photographing.
    - b. Measurement Rate, Accuracy: Film resolution should permit droplet diameter measurement to 0.1 mm. Camera framing rate of 2 frames per second shall be accurate to  $\pm 0.1$  frames per second.

3.3 FLIGHT REGIME:

- a. Orbital Parameters: None
- b. Duration: Two hours
- c. Seasonal Requirements: None
- d. Other Flight Characteristics: Accelerations acting on the test cell during the period of camera observation shall not exceed 0.01 g.
- e. Reasons: Acceleration forces would greatly influence the segregation rate and obscure the surface tension effects.

3.4 SUPPORT EXPERIMENTATION:

- a. Simultaneous Activities: None
- b. Prerequisite Experimentation: All space experiments will be conducted in the laboratory previous to the space flight in order to select, calibrate, and package cameras and determine the appropriate liquids and proportions to be used.

4. OPERATIONS:

4.1 DUTY CYCLE:

- a. Operational Periods: Approximately eight test cells will be observed in zero gravity. Each will be agitated for a period of 1-5 minutes, then photographed for 5 minutes.
- b. Interval: Interval between operational periods not critical.

4.2 CREW REQUIREMENTS:

- a. Astronaut Participation: Astronaut participation is not essential, but could be used to reduce the weight of the experimental package.
- b. Crew Involvement: Manual shaking of the sealed test cells by the crew could be used to eliminate the agitator mechanism.

5. APPARATUS DESCRIPTION:

5.1 METHODS OF MEASUREMENT AND SENSOR DESCRIPTION:

a. Methods of Measurement: Three mutually orthogonal views will be photographed on 16 mm film of the motion and coalescence of suspended droplets within transparent test cells.

b. Sensor Description:

- (1) Equipment Name: Immiscible Fluids Apparatus
- (2) Equipment Size Stored: 0.5 m x 0.5 m x 0.5 m
- (3) Equipment Size Operating: Same as in Item 2
- (4) Equipment Weight: 25 kilograms
- (5) Power Requirements: 250 watts peak
- (6) Environmental Considerations: Temp approx. 25°C; pressure: 5 psi
- (7) Frequency Spectrum: N/A
- (8) Accuracy Considerations: None
- (9) Pointing Accuracy Considerations: Rigid mounting of all cameras will eliminate on-board pointing.
- (10) Development Status: All components are commercially available.
- (11) Reliability: Very reliable.

5.2 DATA COLLECTION:

a. Format: Data will be collected in the form of rolls of film.

b. Amount: Three 100-foot rolls of 16 mm film

SLG-4  
(Sheet 4)

- c. Recovery Advantages: Since all the data will be recorded on film rolls, it is essential to recover these rolls.

5.3 ANCILLARY EQUIPMENT: None

6. CONCEPTUAL DESIGN: See Figure A.4-4.

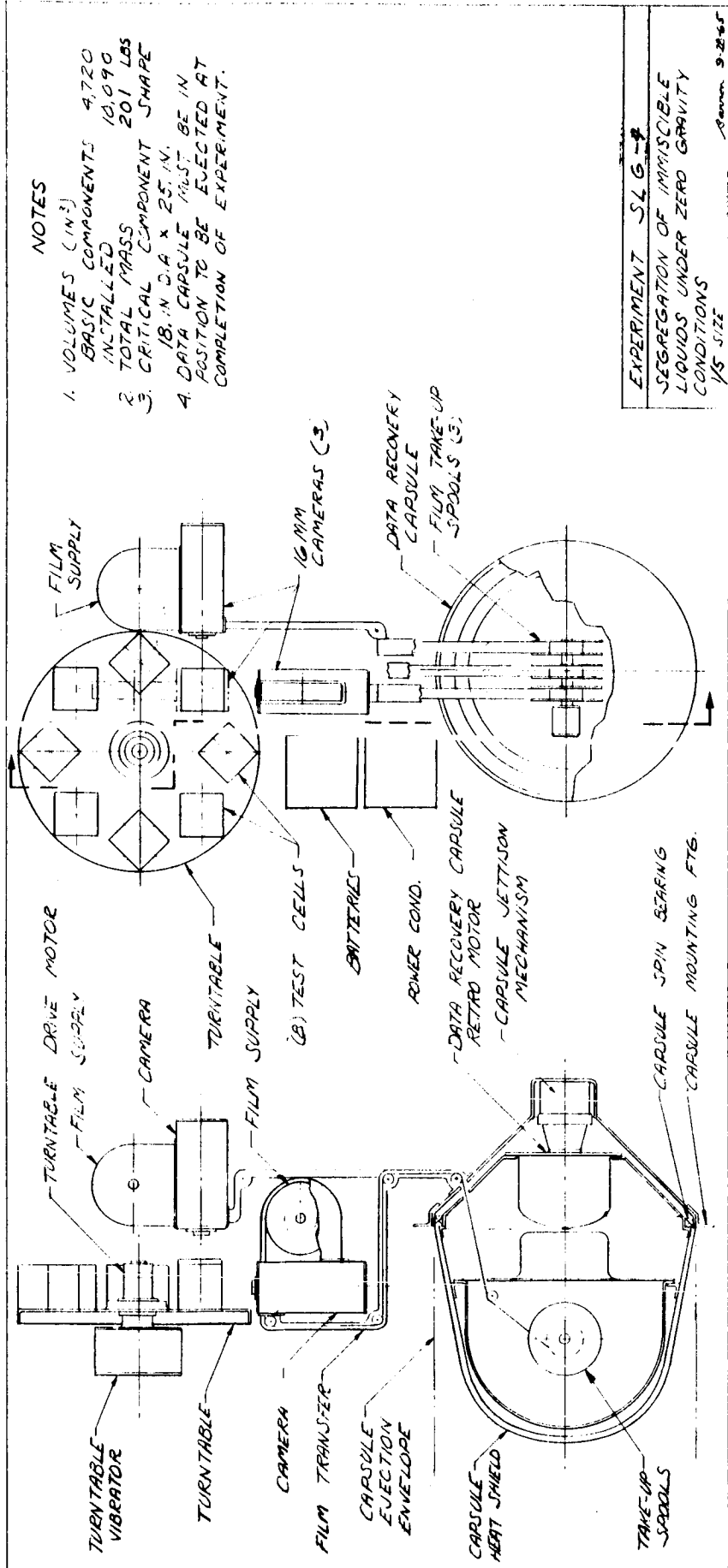

**NOTES**

1. VOLUMES (IN<sup>3</sup>)  
 BASIC COMPONENTS 4,720  
 INSTALLED 10,090
2. TOTAL MASS 201 LBS
3. CRITICAL COMPONENT SHAPE  
 18 IN DIA X 25 IN.
4. DATA CAPSULE MUST BE IN POSITION TO BE EJECTED AT COMPLETION OF EXPERIMENT.

EXPERIMENT SLG-4

SEGREGATION OF IMMISCIBLE LIQUIDS UNDER ZERO GRAVITY CONDITIONS  
 1/5 SIZE

Rev. 9-24-67

Figure A. 4-4 SLG-4 CONCEPTUAL DESIGN DRAWING

1. EXPERIMENT SLG-5: Zero-g Combustion

2. TECHNICAL AREA/APPLICATIONS:

2.1 GENERAL AREA: Solid/Liquid/Gas Behavior

2.2 EXPERIMENT APPLICATIONS: Data on combustion phenomena will be applied to the evaluation of possible safety hazards on manned space vehicles (especially manned orbiting laboratory).

3. EXPERIMENT OBJECTIVES AND SCOPE:

3.1 OBJECTIVES:

- a. Specific Objective: Time-dependent behavior of fuel droplets burning in zero-g condition will be recorded. The combustion process in the absence of convective effects will be observed from initiation to extinction.
- b. Key Techniques: A series of fuel droplets or other combustibles will be ignited in a given amount of oxidizer contained in a test cell. A gas chromatograph will monitor the combustion process. Excess products will be vented to a relief chamber. Upon extinction, the test cell will be purged with oxidizer. The next combustible will then be inserted and ignited.

3.2 MEASUREMENTS AND DATA:

- a. Phenomena to be Observed: Test cell and relief chamber pressures vs time. Temperature-time at 10 points within test cell and 2 points in relief chamber. Amount, type, and time of formation of combustion products. Droplet mass vs time.

- b. Measurement Rate, Accuracy:

Temperature -  $1^{\circ}\text{C}$   
Pressure - .1 psi ( $689 \text{ n/m}^2$ )  
Time - .1 sec  
Droplet mass - 1 milligram

3.3 FLIGHT REGIME:

- a. Orbital Parameters: any
- b. Duration: 35 hours
- c. Seasonal Requirements: none
- d. Other Flight Characteristics: Accelerations acting on the test cell should not exceed 0.01 g.
- e. Reasons: It is desired to observe the entire combustion process, including extinction.

3.4 SUPPORT EXPERIMENTATION:

- a. Simultaneous Activities: Telemetered data shall be monitored for duration of experiment.
- b. Prerequisite experimentation: Test apparatus shall be operated Earthside to provide comparative 1-g data for all specimens.

4. OPERATIONS:

4.1 DUTY CYCLE:

- a. Operational Periods: one operational period 35 hours in duration
- b. Interval: None.

4.2 CREW REQUIREMENTS:

- a. Astronaut Participation: Participation not essential except to recharge gas supplies if all test specimens not utilized on initial fillings.
- b. Crew Involvement: Check gas pressures; refill.

5. APPARATUS DESCRIPTION:

5.1 METHODS OF MEASUREMENT AND SENSOR DESCRIPTION



SLG-5  
(Sheet 3)

- a. Methods of Measurement Pressure transducers will be piezoelectric. Thermocouples will measure temperature. The droplet mass can be measured by capacitance techniques (i.e., use droplet mass as dielectric). Time of formation, amount, and type of combustion product will be determined by the surveyor gas chromatograph designed by Beckman for JPL (Ref. 1).
- b. Sensor Description: Combustion experiment apparatus
  1. Equipment Size Stored: 10 in. x 10 in. x 20 in. (25 m x .25 m x .5 m)
  2. Equipment Size Operating: As above
  3. Equipment Weight: 22 lb (10 kg)
  4. Power Requirements: 10 watts continuous; 40 watts peak
  5. Environment Considerations: Survival temperature range: -185 to +125°C  
Operating temperature range: -50 to +125°C  
Vibration: 42 g peak-to-peak from 20-1500 cps.  
Heat output: Dependent on latent heat of combustibles; will require insulation of test cell and relief chamber plus safety vent for extreme pressure build-up.
  6. Frequency Spectrum: Telemetry modulation approximately 400 cps
  7. Accuracy Considerations: N/A
  8. Pointing Accuracy Considerations: N/A
  9. Development Status: Gas chromatograph available. Test cell, relief chamber, specimen feeding, and ignition system to be developed.
  10. Reliability: Gas chromatograph - good; remainder of apparatus - unknown

SLG-5  
(Sheet 4)

5.2 DATA COLLECTION:

- a. Format: Pulse height and pulse time analysis with some detector amplification of output required for recording. Either real-time transmission or storage on tape for retransmission.
- b. Amount: 35 hours total transmission time of approximately 12 temperatures, 2 pressures, 24 gas components.
- c. Recovery Advantages: N/A

5.3 ANCILLARY EQUIPMENT:

- a. Remote pressure gauges available to astronaut.
- b. Refill system for carrier gas and oxidizer actuated by astronaut.

6. CONCEPTUAL DESIGN: See Figure A.4-5.

REFERENCE: Wilhite, W.F., The Development of the Surveyor Gas Chromatograph, JPL Tech. Rep. No. 32-425, May 15, 1963.

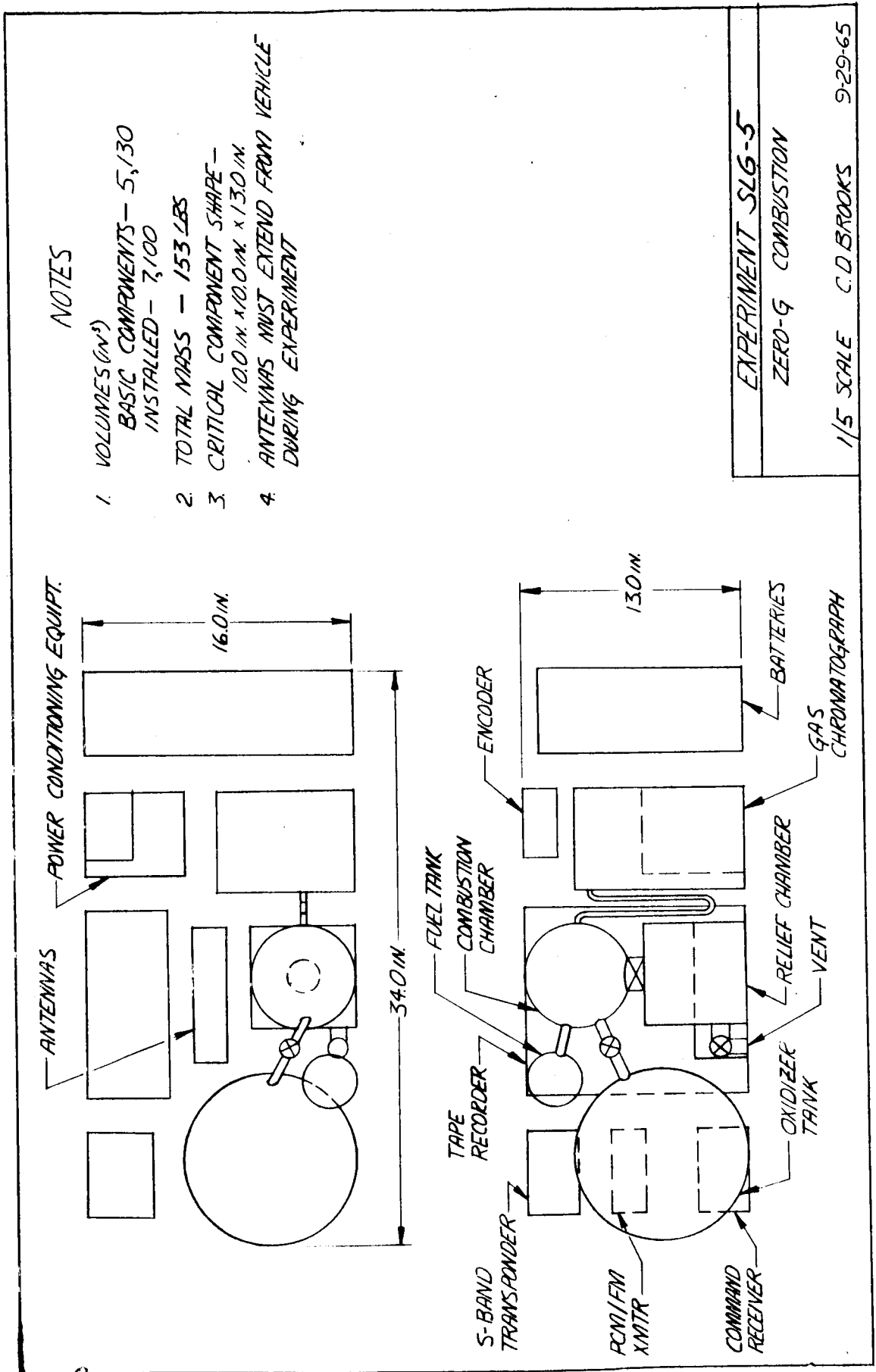

Figure A. 4-5 SLG-5 CONCEPTUAL DESIGN DRAWING

**CATEGORY V - MICROORGANISMS (M)**

The experiments in Category V provide information on the effects of extended space flight on certain microorganisms. The five experiments in this category are designated as follows:

- M-1: Soft Capture, Enumeration, and Identification of Space-Borne Microorganisms**
- M-2: Effects of Space Flight on Morphology, Growth, and Liquid/Gas Separation in Microorganisms**
- M-3: Inherent Mutation Rates in Microorganisms and Effects of Extended Space Flight on the Expression of the Mutation**
- M-4: Determination of the Migration of Microorganisms in a Spacecraft Environment**
- M-5: Production of Nutrients by Certain Microorganisms While in Space Flight.**

A conceptual design drawing for each of the 5 experiments is presented on the last page of each experiment description. In many cases, illustrations and tabular data relating to the experiment are included in the final pages of the description.

1. EXPERIMENT M-1: Soft Capture, Enumeration, and Identification of Space-Borne Microorganisms

2. TECHNICAL AREA/APPLICATIONS:

2.1 GENERAL AREA: Microorganisms

2.2 EXPERIMENT APPLICATIONS: To demonstrate the possibility of free forms of living matter existing in space at orbital altitudes as potential vehicle contaminants.

3. EXPERIMENT OBJECTIVES AND SCOPE:

3.1 OBJECTIVES:

a. Specific Objectives: To soft-capture and cultivate anaerobic and aerobic life forms on exposed plates of adhesive silicon resins adapted to space environments and to determine the presence or absence of growth, both aerobic and anaerobic.

b. Key Techniques: Transparent plates covered with an adhesive silicon resin adapted to space environments are deployed into the orbital atmosphere for an extended period. Life forms in the orbital atmosphere adhere to the surface of the plates. The plates are withdrawn into the vehicle and incubated for a specified period, after which they are observed for presence of growth exhibited by most Earth organisms. Results of scanning by microscope are transmitted to an Earth laboratory and evaluated.

3.2 MEASUREMENTS AND DATA:

a. Phenomena to be Observed:

(1) Morphological characteristics of micro-particles

(2) Growth phenomena of living forms, if present

(3) Number of particles occurring on plate area

(4) Probability of occurrence of living forms in orbital environments/unit area.

b. Measurement Rate, Accuracy: Resolution necessary to observe the phenomena identified above successively: Microscope with micron resolution.

### 3.3 FLIGHT REGIME:

a. Orbital Parameters: None

b. Duration: In-flight duration of experiment should be as long as possible.

c. Seasonal Requirements: No seasonal, launch-year, diurnal, etc., requirements.

### 3.4 SUPPORT EXPERIMENTATION:

a. Simultaneous Activities: Pictures of Microscopic scanning of the incubating plates will be transmitted by television to an Earth station where they will be monitored and studied.

b. Prerequisite Experimentation: Evaluation of instrumentation should be made in simulated space environment as prerequisite to Earth/space experimentation.

## 4. OPERATIONS:

### 4.1 DUTY CYCLE:

a. Operational Period: Soft capture plates will be exposed for duration of the flight. Flight to last as long as possible. There is no dependence on spatial location of measurements as presently conceived.

- b. Interval: After plates are exposed they will be scanned microscopically. Following an incubation period of 2-3 days the plates will be scanned again for presence of growth.

#### 4.2 CREW REQUIREMENTS:

- a. Astronaut Participation: Astronaut participation not essential.
- b. Crew Involvement: Crew involvement is not necessary.

### 5. APPARATUS DESCRIPTION:

#### 5.1 METHODS OF MEASUREMENT AND SENSOR DESCRIPTION:

- a. Methods of Measurement: An optical microscope will be set up equipped with a television camera to transmit data to an Earth laboratory where photomicrographs can be developed and evaluated.
- b. Sensor Description:
  - (1) Exposure plates: 11 x 11 x 1/16-inch dimensions at stored and operating conditions. Boom plus plates weighs approximately 2-5 pounds. Power requirement is 50 watts. Retracted plates (in experimental package) will be in constant temperature of 80°F, approximately 90% relative humidity, and sea-level atmospheric pressure. Frequency spectrum: not applicable. Accuracy and pointing are negligible considerations. Development status is in preliminary stages. Reliability is good.
  - (2) Optical microscope: 12 x 6 x 6-inch dimensions at stored and operating conditions. Weight is 15-20 pounds. Power requirements are 50 watts. The microscope will be at a constant temperature of 80°F, approximately 90% relative humidity, and sea-level atmospheric pressure. Frequency spectrum is not applicable. Accuracy down to 1-micron optical resolution. Reliability excellent.

- (3) Television setup on microscope: The miniaturized TV transmitter weighs 10 pounds. Power requirements are 5 watts. The transmitter will be at a constant temperature of 80°F, approximately 90% relative humidity, and sea-level atmospheric pressure. The frequency spectrum is not applicable. The developmental status of miniaturized television transmitters is unknown. The reliability should be excellent.

5.2 DATA COLLECTION:

- a. Format: Data will be in the form of photographs illustrating the presence of growth or distinctive morphology of the captured organisms or living particles. The photomicrographs, transmitted to an Earth station by television, will be available for permanent access for evaluation.
- b. Amount: Number of pictures may vary from 100 to 500.
- c. Recovery Advantages: Recovery of the package would greatly facilitate the examination of the plates and enable the experimenter to identify the organism as to genus and species.

- 5.3 ANCILLARY EQUIPMENT: No ancillary equipment is anticipated.

CONCEPTUAL DESIGN: See Figure A.5-1.



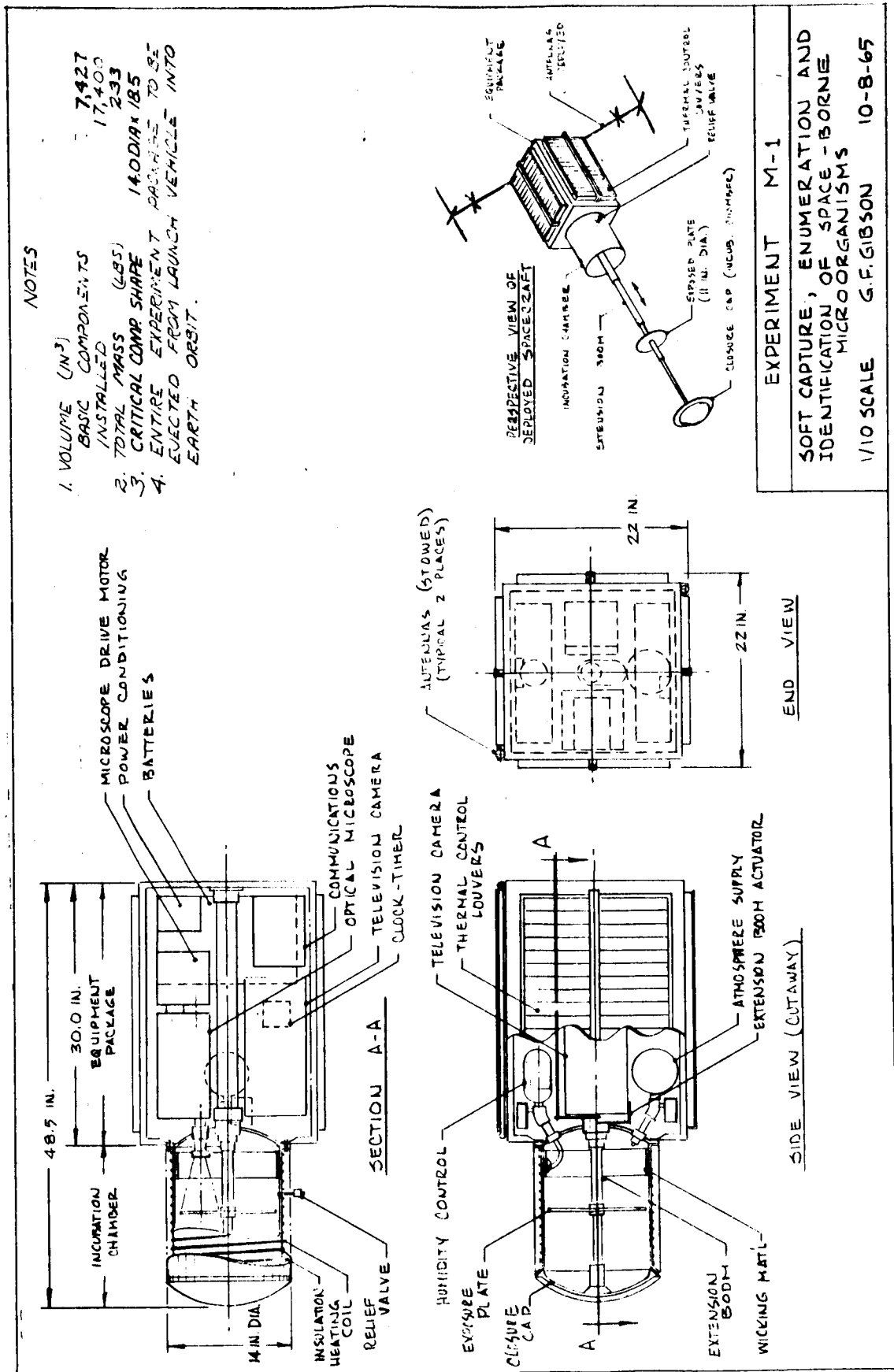

Figure A. 5-1 M-1 CONCEPTUAL DESIGN DRAWING

1. EXPERIMENT M-2: Effects of Space Flight on Morphology, Growth, and Liquid/Gas Separation in Microorganisms.
2. TECHNICAL AREA/APPLICATIONS:
  - 2.1 GENERAL AREA: Microorganisms
  - 2.2 EXPERIMENT APPLICATIONS: To determine the effects of space flight on possible changes in size or shape of microorganisms exposed to a space environment, and to detect changes in growth rate, if present. The hypothesis that gaseous metabolic products of a non-motile organisms remain as an envelope surrounding the cell in quiescent aqueous solutions and consequently interfere with normal metabolism will be tested. Changes observed will provide information of such effects applicable to man and related to biomedical investigations.
3. EXPERIMENTAL OBJECTIVES AND SCOPE:
  - 3.1 OBJECTIVES:
    - a. Specific Objectives: The specific objectives are to measure the effects of space flight environments on cell proliferation of E. coli (coliform bacterium) and to observe the influence of these environments on size and shape of this organism by means of microscopy.
    - b. Key Techniques: Cultures of E. coli will be incubated in a suitable liquid culture medium and observed under high-power magnification (micron resolution) for changes in shape and size as affected by space environments. The rate of multiplication will be measured by means of a spectrophotometric record of increase in density. Consideration will be given to the need to provide a small growth chamber shielded from radiation and a microscope permitting high-resolution photomicrography with a built-in culture chamber. The experiment package will contain necessary electronic circuitry for input to a subcarrier oscillator.
  - 3.2 MEASUREMENTS AND DATA:
    - a. Phenomena to be Observed: Phenomena and characteristics to be observed are differences in cell size and shapes

under the adverse environments compared with those exhibited in the control environment. Probability estimates will be determined of the number of cells affected. The gas envelope, if present, will be observed under phase microscopy at high magnification, and the presence or absence determined by observation.

- b. Measurement Rate, Accuracy: The resolution needed to successfully observe the phenomena identified above is at the micron level. Examinations of the cultures and photographs would be taken during active growth stages (logarithmic stage) as well as the lag growth stage. CO<sub>2</sub> will be measured at the 20-50 ppm quantity.

### 3.3 FLIGHT REGIME:

- a. Orbital Parameters: No required values of orbital parameters.
- b. Duration: In-flight duration of experiment should not be less than three days when culture temperatures and pressures are at sea level.
- c. Seasonal Requirements: No seasonal, launch year, diurnal, etc., requirements.

### 3.4 SUPPORT EXPERIMENTATION:

- a. Simultaneous Activities: Simultaneous Earth laboratory observation in experimental setup and observations of space activities of experimental setup through telemetry.
- b. Prerequisite Experimentation: Evaluation of instrumentation should be made in simulated space environment as a prerequisite to Earth/space experimentation.

## 4. OPERATIONS:

### 4.1 DUTY CYCLE:

- a. Operational Period: Duration of operational periods will be approximately 3-6 days.
- b. Interval: Observations will take place approximately every 4-6 hours.

4.2 CREW REQUIREMENTS:

- a. Astronaut Participation: Astronaut participation not essential.
- b. Crew Involvement: No crew involvement necessary.

5. APPARATUS DESCRIPTION:

5.1 METHODS OF MEASUREMENT AND SENSOR DESCRIPTION:

- a. Methods of Measurement: Methods of measurement will include:
  - (1) Optical density
  - (2) Photomicrographs
  - (3) Spectrophotometry
  - (4) Chemical determination of CO<sub>2</sub> from metabolism
- b. Sensor Description: Expected experiment sensors are:
  - (1) Optical microscope set up, including photomicrograph, measures approximately 12 x 6 x 6 inches in stored and operating conditions. Weight is 15-20 pounds. Power requirements are negligible. Experimental package should be kept at approximately 80°F, 90% relative humidity, and pressure maintained at sea level. No frequency spectrum considered at this time. The photo-optical setup should be accurate in the micron resolution range. Development status of apparatus is unknown, but theoretical reliability is judged excellent.

- (2) Spectrophotometry: Miniature spectrometer set at a specific wavelength with appropriate circuitry would measure approximately 6 x 6 x 6 inches in stored and operating conditions. Weight is 20-25 pounds. Power requirements are negligible. Instrumentation should be in atmosphere of package (80°F, 90% relative humidity, and sea level pressure). No frequency spectrum considered at this time. Accuracy of the standard spectrophotometer will be sufficient. Analysis of the data will determine accuracy of density determinations.
- (3) Gas chromatograph unit: Miniature gas chromatographic unit with appropriate circuitry would measure approximately 8 x 8 x 8 inches in stored and operating conditions. Weight is 30-40 pounds and power requirements are minimum. Instrumentation should be in atmosphere of package (80°F, 90% relative humidity, and sea level pressure). No frequency spectrum considered at this time. Accuracy of the standard gas chromatograph will be sufficient.

## 5.2 DATA COLLECTION:

- a. Format: Pictorial data will be gathered, and the photographs will be evaluated for the presence of gaseous envelopes surrounding the cells. Density measurements of colony growth will be made, and growth of the organism determined by these results. CO<sub>2</sub> evolved will be considered as another means of evaluating metabolic changes occurring in growth of the organism.
- b. Amount: Total bulk of data to be gathered with reference to photomicrographs will include 100 to 500 photographs through the experimental period. Turbidity or density measurements will take place every hour for the period of the experiment. Carbon-dioxide volume measurements will be taken every hour for the period of the experiment.

- c. Recovery Advantages: Physically recovering the experiment package would not appreciably facilitate the data collection.

5.3 ANCILLARY EQUIPMENT: None anticipated.

6. CONCEPTUAL DESIGN: See Figure A.5-2.

NOTES

1. VOLUMES (in<sup>3</sup>)  
    BASIC COMPONENTS- 3,218  
    INSTALLED- 6,916
2. TOTAL MASS - 165 LBS.
3. CRITICAL COMPONENT SHAPE - 160x80x80
4. ANTENNAS MUST EXTEND FROM VEHICLE DURING EXPERIMENT

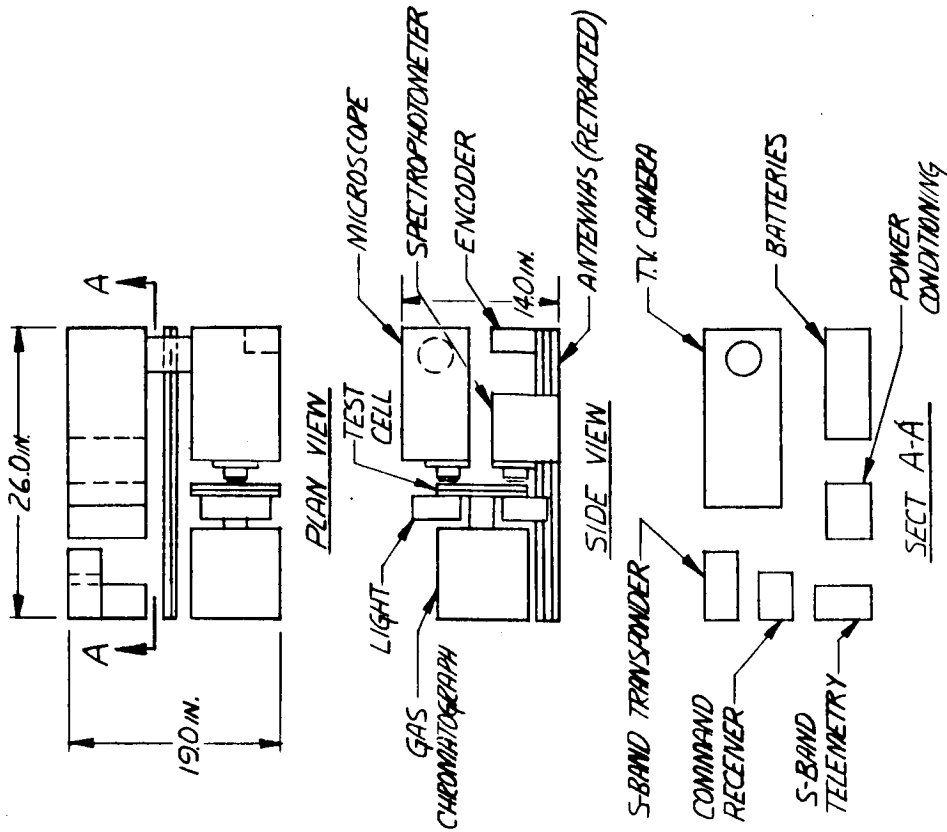

EXPERIMENT M-2

EFFECTS OF SPACE FLIGHT ON  
 MORPHOLOGY, GROWTH, AND LIQUID/GAS  
 SEPARATION IN MICROORGANISMS  
 1/10 SCALE C.D. BROOKS 9-28-65

Figure A. 5-2 M-2 CONCEPTUAL DESIGN DRAWING

1. EXPERIMENT M-3: Inherent Mutation Rates in Microorganisms and Effects of Extended Space Flight on the Expression of the Mutation
2. TECHNICAL AREA/APPLICATIONS:
  - 2.1 GENERAL AREA: Microorganisms
  - 2.2 EXPERIMENT APPLICATIONS:
    - a. To demonstrate the effects of zero gravity on the expression of naturally occurring mutations of a gastrointestinal organism normally resistant to antibiotics. The effect is related to genetic studies on antibiotic resistance of human inhabiting microorganisms.
    - b. To investigate the fundamental relationship of weightlessness and the physiological responses of naturally occurring mutants of human inhabiting organisms to a specific substrate, such as antibiotics. The results may be extrapolated to the effects possible with other organisms and undergoing natural mutations of one type or another. The results also may be associated with health aspects of future long-term flights and planetary explorations.
3. EXPERIMENT OBJECTIVES AND SCOPE:
  - 3.1 OBJECTIVES:
    - a. Specific Objectives:
      - (1) To cultivate a sufficient number of bacterial cells of E. coli for each replication, so that the probability of natural mutation is high.
      - (2) To include these cells in a spacecraft experimental package and determine the rate of mutation which has occurred, as well as the extent of the ability of the mutant cells to grow in the presence of the antibiotic at specified concentrations.



- b. Key Techniques: Optical equipment with about 100-micron resolution will be provided. The replications contained on micropore filters, or similar-type materials, will be observed through an optical microscope every 2 days for a period of from 1 to 30 days, or extent of the mission. Photographs transmitted to an Earth station will be studied and the number, size, and characteristics of colonies measured for each replication.

### 3.2 MEASUREMENT AND DATA:

- a. Phenomena to be Observed: The number, size, and growth characteristics of colonies present in the test and control situations will be determined. No measurement of secondary environmental factors is anticipated; however, package environmental factors will be monitored to determine the efficiency of their function.
- b. Measurement Rate, Accuracy: The resolution needed to measure and observe the above phenomena successfully will necessitate the use of a wide-angle optical microscope with a resolution of approximately 100 microns.

### 3.3 FLIGHT REGIME:

- a. Orbital Parameters: No required values of parameters necessary.
- b. Duration: Desired in-flight duration of the experiment is as long as possible.
- c. Seasonal Requirements: No seasonal, launch year, diurnal, etc. requirements.

### 3.4 SUPPORT EXPERIMENTATION:

- a. Simultaneous Activities: Simultaneous Earth/space observations should be carried out on identical setup in Earth station. The bacterial population will be divided: one-half to remain in Earth station under conditions identical with those of the space package (except weightlessness) and other half to be used in the space package.

M-3  
(Sheet 3)

- b. Prerequisite Experimentation: Experimental setup should be tested in Earth laboratory to determine workability of the package.

4. OPERATIONS:

4.1 DUTY CYCLE:

- a. Operational Periods: The experimental package proposed is not dependent upon spatial location as long as conditions simulating Earth atmosphere (14 psi, 80-90°F., 80-90% R.H.) are present in the package.
- b. Interval: Estimated interval between operational periods of equipment will be every 2 days, beginning after 24 hours and continuing until completion of the flight.

4.2 CREW REQUIREMENTS:

- a. Astronaut Participation: Astronaut participation not essential.
- b. Crew Involvement: No crew involvement necessary

5. APPARATUS DESCRIPTION:

5.1 METHODS OF MEASUREMENT AND SENSOR DESCRIPTION:

- a. Proposed Methods of Measurement: Replicated plates containing the test organism will be scanned under approximately 10x-40x (wide angle) magnification (optical microscope), and observations transmitted to Earth station via television camera attached to microscope.
- b. Sensor Description: Optical Microscope: 24 x 6 x 6 inches in a stored position and approximately the same in operation. Weight: approximately 10-15 pounds. Power requirements will be in the range of 25-50 watts for approximately  $\frac{1}{2}$  to 1 hour every two days. The package should be maintained at 80-90°F, 80-90% relative humidity, and at sea level

M-3  
(Sheet 4)

pressure. No heat output, except microscope lamp, is anticipated, vibration should be kept negligible. Frequency spectrum does not appear to be significant. Accuracy of the observations will be dependent upon the quality of optical equipment and resolution of the TV equipment. Development of this set up is preliminary; however, the reliability of the setup appears excellent.

5.2 DATA COLLECTION:

- a. Format: Data will be collected through an optical wide-angle microscope and transmitted to an Earth station by television; photographs taken are to be evaluated by experimenter in Earth laboratory.
- b. Amount: Estimated total bulk of data will be 100-500 photographs for duration of the flight.
- c. Recovery Advantages: Physical recovery of the package would be beneficial but not essential to quality of the results obtained.

5.3 ANCILLARY EQUIPMENT: None anticipated.

6. CONCEPTUAL DESIGN: See Figure A.5-3.

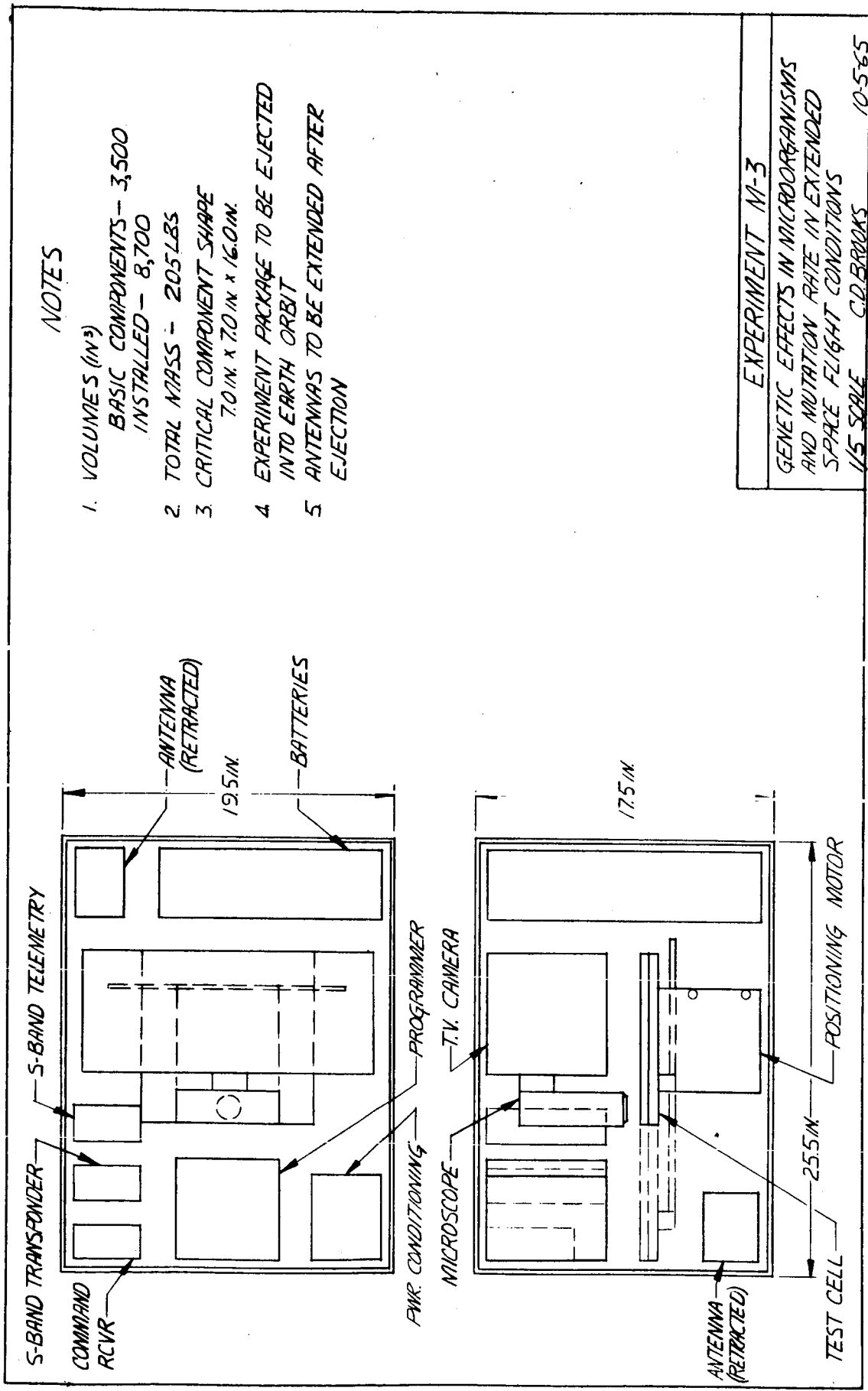

Figure A. 5-3 M-3 CONCEPTUAL DESIGN DRAWING

1. EXPERIMENT M-4: Determination of the Migration of Microorganisms in a Spacecraft Environment
2. TECHNICAL AREA/APPLICATIONS: To demonstrate the migration of fungal spores and bacterial cells which may occur in a space cabin environment as found under space conditions.
  - 2.1 GENERAL AREA: Microorganisms
  - 2.2 EXPERIMENT APPLICATIONS: To determine the migration of microorganisms, fungal spores, and bacterial cells, in the environment of a space cabin under conditions of weightlessness. As a consequence of migration, the spores may come in contact with foodstuffs or other items causing deterioration. Contact with astronaut's skin may provide medium for growth; consequently areas of inflammation may occur if organisms are pathogenic.
3. EXPERIMENT OBJECTIVES AND SCOPE:
  - 3.1 OBJECTIVES: Sporulating colonies of fungi and freeze-dried cells of bacteria will be established at particular points in confined areas of the spacecraft. The spores and cells will be allowed to circulate freely throughout the areas as dictated by the space environment. Sterile nutrient media (incubation sites) are placed at various points within the space environment. The media are examined after 3 through 30 days for evidence of the presence of growth of fungal and/or bacterial colonies.
  - 3.2 MEASUREMENTS AND DATA:
    - a. Phenomena to be Observed: Observations will be made on the pre-selected incubation sites for the presence of growth on the plates by means of a scanning wide-angle low powered microscope lens equipped with a TV camera. The number of colonies on the plates will be determined, and a migration factor calculated considering time, number of colonies, and distance of migration from the original sites. The time required for the migration of the spores will be determined, and the distances the spores or cells have traveled will be estimated in relation to time.

- b. Measurement Rate, Accuracy: Resolution will be of sufficient quality to detect presence or absence of fungal or bacterial colony growth at the incubation sites as represented by the number of colonies per incubation site. The observations will be made at 2-day intervals throughout the flight.

### 3.3 FLIGHT REGIME:

- a. Orbital Parameters: No requirements of orbital parameters, such as perigee, apogee, or inclination. Rolling and pitching should not have an effect on migration in a weightless state.
- b. Duration: In-flight duration of the experiment should be as long as possible.
- c. Seasonal Requirements: No seasonal, launch year, or diurnal, etc. requirements are necessary.

### 3.4 SUPPORT EXPERIMENTATION:

- a. Simultaneous Activities: An Earth laboratory setup will serve as a control for the space flight experiment. Observations will be made in the Earth laboratory experimental setup simultaneously with those in the spacecraft environment.
- b. Prerequisite Experimentation: Prerequisite Earth/space experimentation will be negligible.

## 4. OPERATIONS:

### 4.1 DUTY CYCLE:

- a. Operational Periods: The operational period will be for the duration of the flight. Operational periods for observations by telemetry will be every two days for the duration of the flight. There is no dependence on location of the experimental package in the spacecraft.

- b. Interval: Interval between operational periods will be two days.

4.2 CREW REQUIREMENTS:

- a. Astronaut Participation: No astronaut participation essential for this experiment.
- b. Crew Involvement: No crew involvement.

5. APPARATUS DESCRIPTION:

5.1 METHODS OF MEASUREMENT AND SENSOR DESCRIPTION:

- a. Methods of Measurement: Proposed method of observation will be by low power microscopy with images transmitted to earth station by television.
- b. Sensor Description: Low powered microscope (approximately 10x magnification) with wide angle lens system equipped with television camera and transmission unit. Size of stored and operating unit about 12 x 12 x 6 inches. Weight approximately 30 pounds. Power requirements minimum. Package should be kept at 75-85°F, relative humidity 90-95%, and sea level pressure. Frequency spectrum unknown at present. Development status: theoretical reliability postulated as good. Postulated size of working chamber (interior): 1 x 1 x 1 foot, not including sensor apparatus.

5.2 DATA COLLECTION:

- a. Format: Data will be collected on video tape in a ground station and studied at the convenience of the experimenters.

M-4  
(Sheet 4)

- b. Amount: Total bulk of data will be estimated on volume per day after 3, 5, 7, 9, 11, 13, etc. days (arbitrary intervals). Photographs of individual incubation sites will be taken at the intervals mentioned throughout the duration of a flight of 30 days. Total number of photographs would approximate 100-200.
- c. Recovery Advantages: Physically recovering any portion of the experiment package would not facilitate interpretation of results.

5.3 ANCILLARY EQUIPMENT: Not anticipated.

6. CONCEPTUAL DESIGN: See Figure A.5-4.



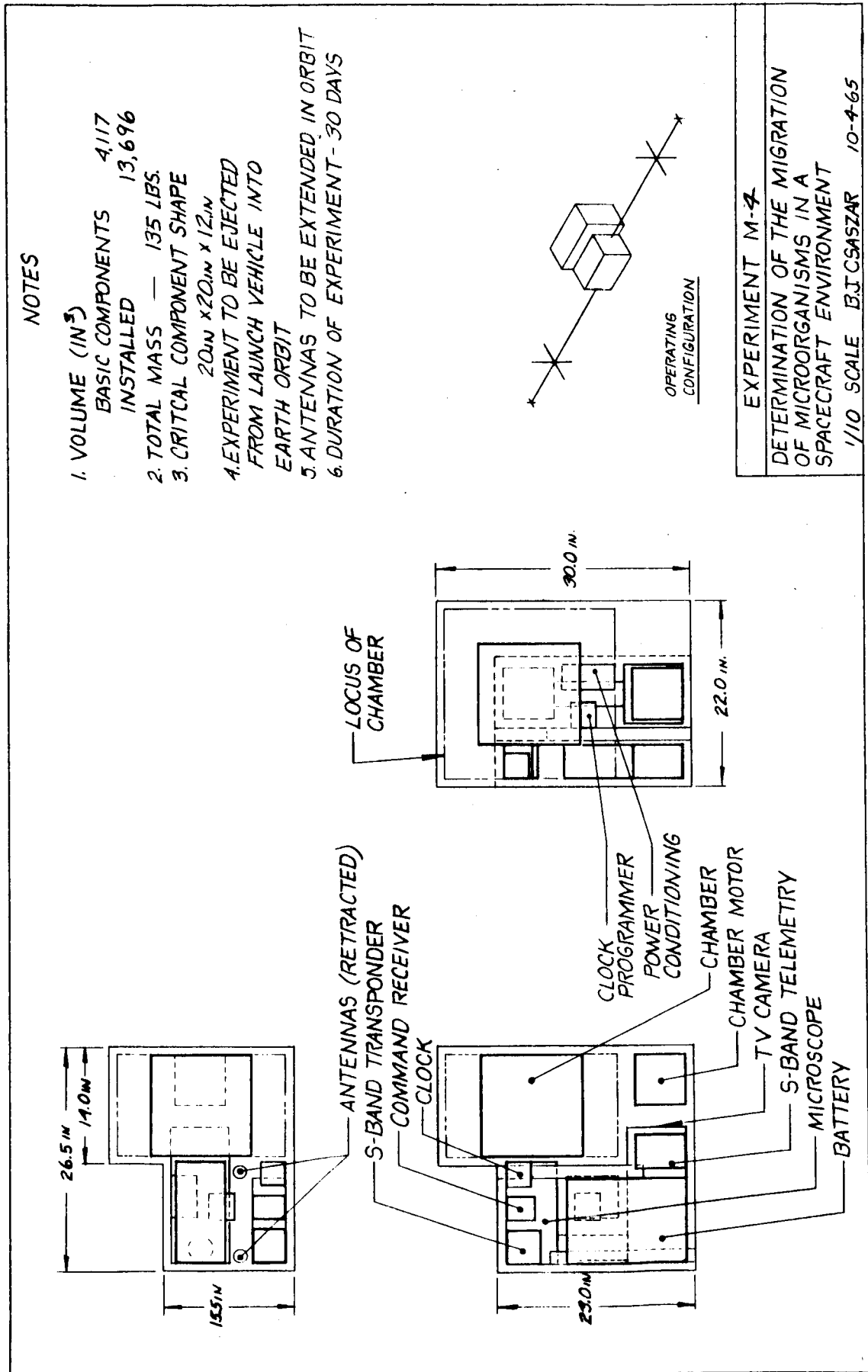

Figure A. 5-4 M-4 CONCEPTUAL DESIGN DRAWING

1. **EXPERIMENT M-5: Production of Nutrients by Certain Microorganisms While in Space Flight.**
2. **TECHNICAL AREA/APPLICATIONS:** To demonstrate the effects of extended space flight on the production of nutrients by microorganisms. In this experiment the utilization of microorganisms in the production of nutrients in a weightless condition and the use of these nutrients as food supplements is considered.
  - 2.1 **GENERAL AREA: Microorganisms**
  - 2.2 **EXPERIMENT APPLICATIONS:** To indicate fundamental problems arising in the production of nutrients by microorganisms where more complex waste materials are used as substrate. The resulting products would be a source of nutrients for astronauts of space explorers.
3. **EXPERIMENT OBJECTIVES AND SCOPE:**
  - 3.1 **OBJECTIVES:**
    - a. **Specific Objective:** A sufficiently replicated experimental setup incorporating nutrient precursor-dependent mutants of selected bacteria and mutants requiring the nutrient will be enclosed in a growth environment separated by bacterial filters (but not nutrient). Demonstration of quality and quantity of growth of nutrient-requiring bacteria will indicate quality and quantity of nutrient production under space flight conditions.
    - b. **Key Techniques:** A series of "U" tubes, each tube divided by a sintered glass filter through which the test organisms will not pass but of sufficient pore size for nutrient diffusion, is inoculated just prior to launch. One arm of the tube is inoculated with a mutant strain dependent on the test nutrient precursor, and the other arm inoculated with a mutant strain producing the nutrient precursor. The nutrient precursor diffuses through the sintered glass filter and is utilized by the mutant requiring the precursor.

Growth rate of the nutrient precursor-dependent mutant will indicate effects of weightlessness on (1) nutrient production and (2) diffusion and utilization of the nutrient precursor. Growth of both organisms will be measured by turbidometric means.

### 3.2 MEASUREMENTS AND DATA:

- a. Phenomena to be Observed: Turbidometric measurements will be made with the aid of a photometer, and the readings electronically transmitted to an Earth station.
- b. Measurement Rate, Accuracy: Resolution of the readings will be of the quality required with generally used photometric instrumentation. Readings should be made hourly for a time period necessary for the cultures to at least reach the log phase in growth. This may require up to ten days, depending upon the effects of the space environment on diffusion of the nutrient precursor and growth of the organism.

### 3.3 FLIGHT REGIME:

- a. Orbital Parameters: No required values of orbital parameters are necessary.
- b. Duration: The desired in-flight duration of the experiment is ten days; however, under Earth conditions growth may be completed after three days.
- c. Seasonal Requirements: No seasonal, launch year, diurnal, etc. requirements.

### 3.4 SUPPORT EXPERIMENTATION:

- a. Simultaneous Activities: Turbidometric readings transmitted to the Earth laboratory are received and stored. Similar readings on Earth laboratory controls are taken.

- b. Prerequisite Experimentation: Prior to Earth/space experimentation, the procedure for space experimentation phase should be evaluated for its effectiveness. It is postulated that the setup will give excellent results.

4. OPERATIONS:

4.1 DUTY CYCLE:

- a. Operational Periods: For the first five days photometric equipment will be in operation for 15-20 minutes every hour; thereafter, once every two days. Spatial location of measurements is not critical.
- b. Interval: Interval between operational period: 1 hour.

4.2 CREW REQUIREMENTS:

- a. Astronaut Participation: Astronaut participation is not essential.
- b. Crew Involvement: No crew involvements.

5. APPARATUS DESCRIPTION:

5.1 METHODS OF MEASUREMENT AND SENSOR DESCRIPTION:

- a. Methods of Measurement: Turbidometric measurements may be taken with the aid of a stationary photometer. The tubes will pass through the light source automatically, and the readings will be transmitted to an Earth station and compared with Earth laboratory controls.
- b. Sensor Description: Photometer: Equipment size stored and operating, approximately 6 x 6 inches. Weight, 8-10 pounds. Power requirements, 20-50

watts for 15 to 20 minutes every two days for duration of flight. The environmental chamber should be kept at 80-90°F, sea level pressure, and 80-90% relative humidity. Frequency spectrum appears insignificant. Development status is preliminary, but reliability is postulated as excellent.

5.2 DATA COLLECTION:

- a. Format: Data to be collected from photoelectric cell, transmitted to Earth station, and recorded with any applicable electronic system.
- b. Amount: Total amount of data will range from 30 to 100 readings for each two-day period for 10-15 days.
- c. Recovery Advantages: There would be no distinct advantages to recovery of the experiment package.

5.3 ANCILLARY EQUIPMENT: No ancillary equipment foreseen at this stage.

6. CONCEPTUAL DESIGN: See Figure A.5-5.

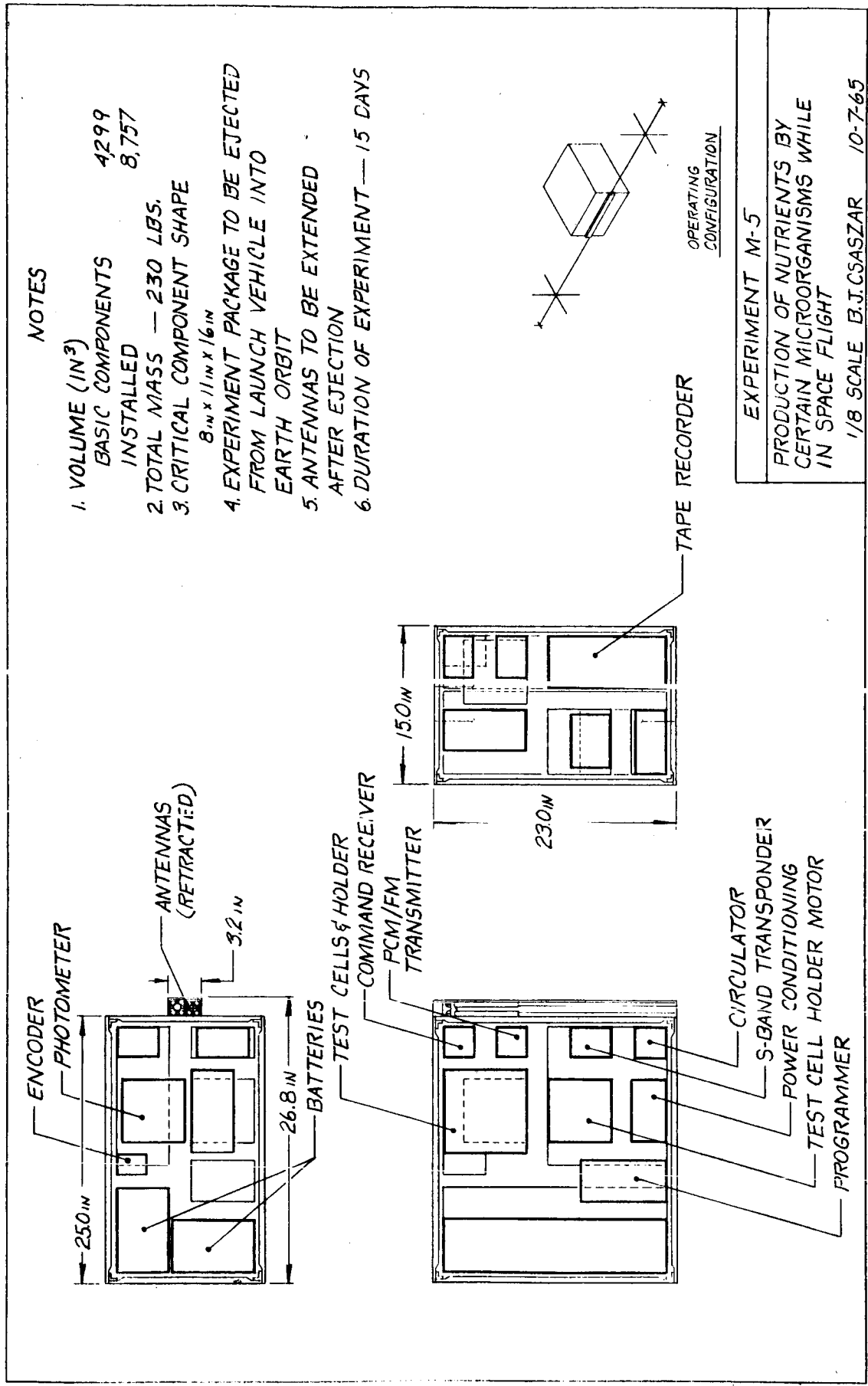

Figure A. 5-5 M-5 CONCEPTUAL DESIGN DRAWING

**CATEGORY VI - OBSERVATIONS OF THE EARTH'S ATMOSPHERE, THE  
SPACE ENVIRONMENT, AND ASTRONOMICAL PHENOMENA (OEA)**

The experiments in Category VI use an Earth-orbiting satellite as a base for astronomical and astrophysical observations. The five experiments in this category are designated as follows:

OEA-1: Radiation Environment Monitoring

OEA-2: Study of Magnetic Field Lines

OEA-3: Test of Phototype Star Tracker

OEA-4: Cosmic-Ray Emulsion Experiment

OEA-5: Emission Line Radiometry.

A conceptual design drawing for each of the 5 experiments is presented on the last page of each experiment description. In many cases, illustrations and tabular data relating to the experiment are included in the final pages of the description.

1. EXPERIMENT OEA-1: Radiation Environment Monitoring
2. TECHNICAL AREA/APPLICATIONS:
  - 2.1 GENERAL AREA: Observations of the Earth's Atmosphere, the Space Environment, and Astronomical Phenomena
  - 2.2 EXPERIMENT APPLICATION: To investigate radiation monitoring.
3. EXPERIMENT OBJECTIVES AND SCOPE:
  - 3.1 OBJECTIVES:
    - a. Specific Objective: The radiation monitoring equipment is used to provide a record of the radiation received by the crew, to supply the external radiation environmental data to other experiments, and to compare the two radiation environments. If the external radiation package is left in orbit, it will provide additional radiation data following the completion of the manned portion of the mission.
    - b. Key Techniques: Techniques which have been established for measuring the external environment and crew dose, such as those used in radiation environments on Earth or those for the Apollo mission or those proposed for operational satellites, will be utilized. The following radiation detection devices are used in these techniques.
      - (1) Proton-alpha spectrometer
      - (2) Electron-spectrometer
      - (3) Tissue equivalent ionization chambers
      - (4) Film packs and pocket dosimeters
      - (5) Linear energy transfer spectrometer
      - (6) X-ray detector
      - (7) Gamma-ray detector
      - (8) Neutron detector.



### 3.2 MEASUREMENTS AND DATA:

a. Phenomena to be Observed: The following measuring devices and measurements are to be employed:

- (1) Tissue equivalent ionization chambers to record dose rates in the range 0.2 rad/hr to 500 rad/hr.
- (2) Film pack for a permanent record of doses greater than one rad received by the crew.
- (3) Electron spectrometer to measure the external electron environment  $40 \text{ keV} < E_e < 3 \text{ MeV}$ .
- (4) Proton spectrometer to measure the external proton environment for  $E_p$  from 1 to 60 Mev and  $E_p > 60 \text{ MeV}$ .
- (5) Alpha spectrometer to measure the external alpha-particle environment for  $E > 10 \text{ MeV}$ .
- (6) Linear energy transfer spectrometer capable of measuring the LET from 0.2 keV/ $\mu$  to 500 keV/ $\mu$ .
- (7) X-ray detector such as an end-window Geiger counter for measuring 0.1 to 10 keV X-rays.
- (8) Gamma-ray spectrometer for measuring gamma-ray spectrum between 0.1 and 10 Mev.
- (9) Neutron detector to measure neutrons over the energy range of from 0.1 to 30 Mev.

Certain modifications, such as range changes, may be made, depending on the orbit selected; and some items, such as the X-ray and gamma-ray sensors, could be omitted from low-inclination orbits if weight limitations call for reduction.

b. Measurement Rate, Accuracy: A 57-degree resolution.

### 3.3 FLIGHT REGIME:

a. Orbital Parameters: This experiment may be performed in all orbits but is particularly significant in polar or synchronous orbits.

- b. Duration: For duration of mission or for the measurement associated with the crew for the period of occupancy by a particular flight crew.
- c. Seasonal Requirements: None
- d. Other Flight Characteristics: None
- e. Reasons: Orbit may be chosen to eliminate interference from geomagnetically trapped particles, but this is not an absolute necessity.

3.4 SUPPORT EXPERIMENTATION:

- a. Simultaneous Activity: None, except report of solar flare activity and prediction of possible hazard from Earth.
- b. Prerequisite Experimentation: The Apollo command module shielding verification should be completed and the results analyzed before the orbit missions are undertaken.

4. OPERATION:

4.1 DUTY CYCLE:

- a. Operational Periods: The data will be collected continuously. The film packs will be collected and returned to Earth at the end of the mission.
- b. Interval: None

4.2 CREW REQUIREMENTS:

- a. Astronaut Participation: It is essential that the individual dosimeter be carried by the astronaut inside the vehicle. While it would still be valuable to obtain the data without astronaut participation, the objective of analyzing the radiation received by an astronaut during normal operations for his stay time would not be as validly met without the astronaut's participation. The collection and preparation of the film packs for return to Earth will be enhanced by the availability of the astronaut.

OEA-1  
(Sheet 4)

- b. Crew Involvement: The crew members would have to wear small dosimeters constantly and read off the results and recharge them, normally once a day. This operation would take five minutes per day. The other instruments would operate automatically. If there is an unusual event, it may be decided to obtain measurements immediately afterward.

These unusual events may occur once every two weeks. It will take 30 minutes to collect the film packs at the end of the experiment period and 30 minutes to prepare them for return to Earth.

5. APPARATUS DESCRIPTION: See Table A.6-1

5.1 METHODS OF MEASUREMENT AND SENSOR DESCRIPTION:

- a. Methods of Measurement. The spectrometers and X-ray and neutron detectors will be mounted in locations suitable for their measurement and will be turned on at the beginning of the mission and run continuously. The data will be stored on magnetic tape and relayed to Earth every orbit (or as required). There will also be a simple computer, commutator, pulse height analyzer, and recorder. It is assumed that an Earth telemetry system is available.

For the individual astronaut dosimeters see Item 4.2-b. These will not require a tape for the storage of data.

The film packs and nuclear emulsions will be returned to Earth where they will be processed and analyzed.

- b. Development Status: All of the instrumentation discussed in this experiment will be available and will not require any special development work other than adapting instruments to the particular mission.

5.2 DATA COLLECTION:

a. Format:

- (1) Data from the film packs will require recovery, packaging, and return to Earth for processing.
- (2) Data from the pen dosimeters will be read daily by the astronaut, recorded, and relayed to Earth.
- (3) Data from the spectrometers, the tissue-equivalent ionization chamber, and the nuclear counters will be stored on magnetic tape; as the tape is purged once per orbit on command from an Earth station, the data are telemetered to Earth. (If the data are purged less than once per orbit, the magnetic memory storage will have to be increased by 12,500 bits per orbit.)

- b. Amount: The film packs and emulsions will be returned at the end of the mission or during a crew change. There will be no other data requirements.

The remainder of the equipment will yield approximately 12,500 bits per orbit.

- c. Recovery Advantages: The film packs and nuclear emulsions will have to be recovered in order to develop and analyze them.

5.3 ANCILLARY EQUIPMENT: Pulse-height analyzer and magnetic memory storage of approximately 12,500-bit capacity for recovery of data every orbit.

6. CONCEPTUAL DESIGN: See Figure A.6-1.

TABLE A. 6-1  
OEA-1 EQUIPMENT LIST

Equipment Name	Volume		Weight (lbs.)	Peak (Watts)	Duty (Watts)	Environmental Considerations	Data Spectrum	Accuracy Considerations	Pointing Accuracy	Reliability
	Stored	Operating								
Electron Spectrometer Detector	3"x3"x6" 54 cu. in.	3"x3"x6"	4			0 - 160°F	Electron Energy 40 Kev. to 3 Mev	5%	None req'd	95%
Proton-alpha Spectrometer Detector	6"x6"x12" 432 cu. in.	6"x6"x12"	6			"	Photo Energy 1 Mev to 60 Mev & those over 60 Mev	5%	"	95%
Tissue-Equivalent Ionization Chambers	2"dia x 5" long 8"cu in	2"dia x 5" long	3	0.1		"	Dosage 0.2 rad/hr to 500 rad/hr	5%	"	90 - 95%
Film Packs and Pen Dosimeter & Charger	2"x2"x4" 16 cu in	2"x2"x4"	1	N/A	N/A	25-30°F	Dosage	5%	"	"
LEI Spectrometer Detector	6"x6"x6" 216 cu in	6"x6"x6"	3	0.1		0 - 160°F	0.2Kev/ to 500 Kev/	5%	"	"
X-ray Spectrometer Detector	2" Dia x 6" long 5π cu in	2" Dia x 6" long	1	2.0		"	X-ray energy 0.1 Kev to 10 Kev	5%	"	"
Gamma Ray Spectrometer Detector	4"x4"x2" 32 cu in	4"x4"x12"	5	0.1		"	Gamma Ray Energy 0.1 Kev to 10 Kev	5%	"	"
Neutron Detectors	3"x3"x3" 27 cu in	3"x3"x6"	7	0.1		"	Neutron Energy 0.1 Mev to 30 Mev	5%	"	"
Accessory Electronics	<u>1 cu.ft.</u> 2543 cu.in.	1 cu.ft.	<u>15</u> 45	<u>3.0</u> 5.4 watts		"				

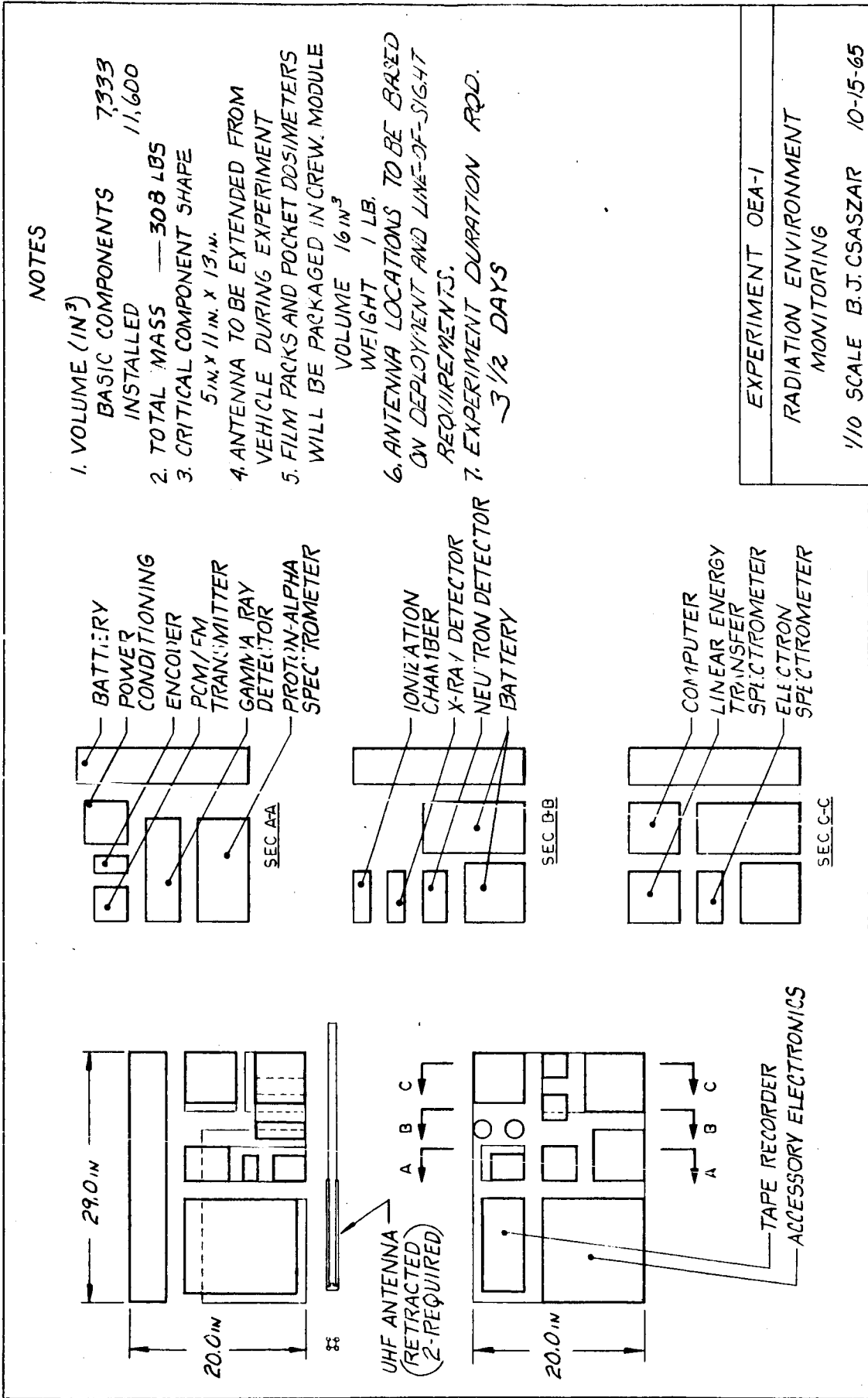

Figure A. 6-1 OEA-1 CONCEPTUAL DESIGN DRAWING

1. EXPERIMENT OEA-2: Study of Magnetic Field Lines

2. TECHNICAL AREA/APPLICATIONS:

2.1 GENERAL AREA: Observations of the Earth's Atmosphere, the Space Environment, and Astronomical Phenomena

2.2 EXPERIMENT APPLICATIONS: To provide more accurate definition of the geometry of the Earth's magnetic field lines.

3. EXPERIMENT OBJECTIVES AND SCOPE:

3.1 OBJECTIVES:

a. Specific Objective: The objectives of this experiment are to observe and study the geometry of the lines of force of the terrestrial magnetic field by measuring the paths followed by artificially injected electrons.

b. Key Techniques: A linear accelerator will be used to inject 1-millisecond-long pulses of 10-kw electrons along a terrestrial, magnetic field line. When these electrons contact the atmosphere, an auroral spot is produced which can be tracked visibly by motion picture photography or radar from stations other than the AES spacecraft. Several types of motion of field lines are expected, such as diurnal and solar cycle motions due to quiescent solar wind-magnetosphere interaction and the perturbations due to magnetic storms. By changing the beam energy, one could learn about large-scale electric fields from the  $\vec{E} \times \vec{B}$  drift.

The electrons will be injected from a low-altitude satellite. The satellite position at the time of injection, in connection with the local magnetic field direction at this point, will determine one conjugate point. The electrons spiral along the field line to a conjugate point in the opposite hemisphere where, because of the dispersion of energy, the pulse of electrons will arrive over a period of 50 to 100 msec. Since the radius of

gyration of a 10-kev electron in an 0.2-gauss field is about 17 meters, the rate of energy deposition of a 1-msec, 0.1-amp pulse of electrons in a square centimeter column of the atmosphere will be

$$(10^4 \text{ ev}) \left( \frac{0.1}{1.6 \times 10^{-19}} \text{ SEC}^{-1} \right) \left( \frac{1}{100} \right) \left( \frac{1 \text{ cm}^{-2}}{\pi (17)^2 10^4} \right) = 6.9 \times 10^{13} \text{ ev cm}^{-2} \text{ sec}^{-1}$$

The satellite moves only 6 to 7 meters during the injection, and, therefore, this motion makes only a negligible increase in the area of the spot. It has been found that the strongest auroral emission line is the 3914A line of  $N_2$ . For this line, about  $2100 \text{ ev cm}^{-2} \text{ sec}^{-1}$  of ionizing energy must be deposited per emitted quantum. Thus the electron pulse will cause the emission of about  $3 \times 10^{10}$  quanta per second (30 kilorayleigh) over an area of about  $900 \text{ M}^2$  for a period of about 50 milliseconds. Since an auroral display with an intensity as low as 50 rayleigh is observable in auroral patrol spectrographs, this bright spot should be easily detectable.

### 3.2 MEASUREMENTS AND DATA:

- a. Phenomena to be Observed: The conjugate points of terrestrial magnetic field lines will be measured by observing them optically and obtaining a time function measurement of their geometry and spatial coordinates. The measurements may be made from Earth, aircraft, balloons, or from a second spacecraft.
- b. Measurement Rate, Accuracy: The electron gun that injects electrons must be aligned within five degrees of the magnetic field line at the point of injection. The observing and recording instruments will have to be able to observe a visible spot 35 meters in diameter.



3.3 FLIGHT REGIME:

- a. Orbital Parameters: Orbit should be relatively low: 200 n.mi. or below. The inclination should be as close to 90 degrees as feasible so that all field lines will be crossed.
- b. Duration: The duration of the experiment may be as long as the mission, but for an optimum orbit a figure of 50 orbits may be used.
- c. Seasonal Requirements: None
- d. Other Flight Characteristics: None
- e. Reasons: To cross all magnetic field lines, and to avoid interference from the Earth's natural radiation belts.

3.4 SUPPORT INSTRUMENTATION:

- a. Simultaneous Activity: There will have to be Earth-based (or equivalent) observatories to observe the auroral displays.
- b. Pre-requisite Experimentation: None

4. OPERATIONS:

4.1 DUTY CYCLE:

- a. Operation Periods: 15 minutes per operation for 50 operations.
- b. Interval: Approximately one-half day.

4.2 CREW REQUIREMENTS:

- a. Astronaut Participation: Initial instrument checkout, once per mission, 30 minutes. During experiment operation 10 minutes/day instrument check.

- b. Crew Involvement: The crew involvement will be to perform the initial instrument setup and checkout and to perform periodic checks at intervals defined above. Also possibly 10 minutes/day will be required to turn instruments on and off.

5. APPARATUS DESCRIPTION:

5.1 METHODS OF MEASUREMENT AND SENSOR DESCRIPTION:

- a. Methods of Measurement: The measurements and acquisition of data will be done by optical methods and will be accomplished from observation points other than the spacecraft.

The electron gun will be operated from the spacecraft. A flux-gate magnetometer will be used to orient the gun along the magnetic field lines.

- b. Sensor Description:

- (1) Equipment Name: Electron Gun Assembly

- (2) Equipment size, stored:

- (a) Electron Gun: 4-inch diameter x 9-inch length

- (b) Gimbal Mount: 9 x 9 x 12 inches

- (c) Power Supply: 12 x 14 x 10 inches

- (d) Magnetometer: 8-inch diameter x 12-inch length

- (3) Equipment size, operating: Same as Item (2).

- (4) Equipment weight: Approximately 100 pounds.

- (5) Power requirements: Duty cycle, 200 watts for 15 minutes. Off other times (15 min/orbit).

- (6) Environmental considerations: Normal for electronics

- (7) Frequency Spectrum: N/A
- (8) Accuracy considerations: Orientation accuracy 1/2 degree on each of the coordinate axes.
- (9) Pointing accuracy: Within 5 degrees of magnetic field lines.
- (10) Development status: This type of electron gun would require development. There is presently none available. The observing optics would also have to be developed or present systems modified.
- (11) Reliability: 95 percent

5.2 DATA COLLECTION:

- a. Format: Information on electron gun position, pointing, and electron pulse can be stored on magnetic tape, and the information telemetered to Earth.
- b. Amount: Total bits per experiment for on-board equipment data is approximately 1000. (There will be film records taken from other stations.)
- c. Recovery Advantages: If the information were telemetered to Earth, there would be no distinct advantage in physically recovering any portion of the experiment package.

5.3 ANCILLARY EQUIPMENT: On-board magnetic tape storage of instrument data. Flux-gate magnetometer for aligning along magnetic field lines.

6. CONCEPTUAL DESIGN: See Figure A.6-2.

NOTES

1. VOLUME (IN<sup>3</sup>)  
 BASIC COMPONENTS 7,700  
 INSTALLED 19,600
2. TOTAL MASS (LBS) 312
3. CRITICAL COMPONENT SHAPE  
 13.5 x 15.2 x 21.0
4. ENTIRE EXPERIMENT PACKAGE TO  
 BE EJECTED FROM LAUNCH VEHICLE  
 INTO EARTH ORBIT

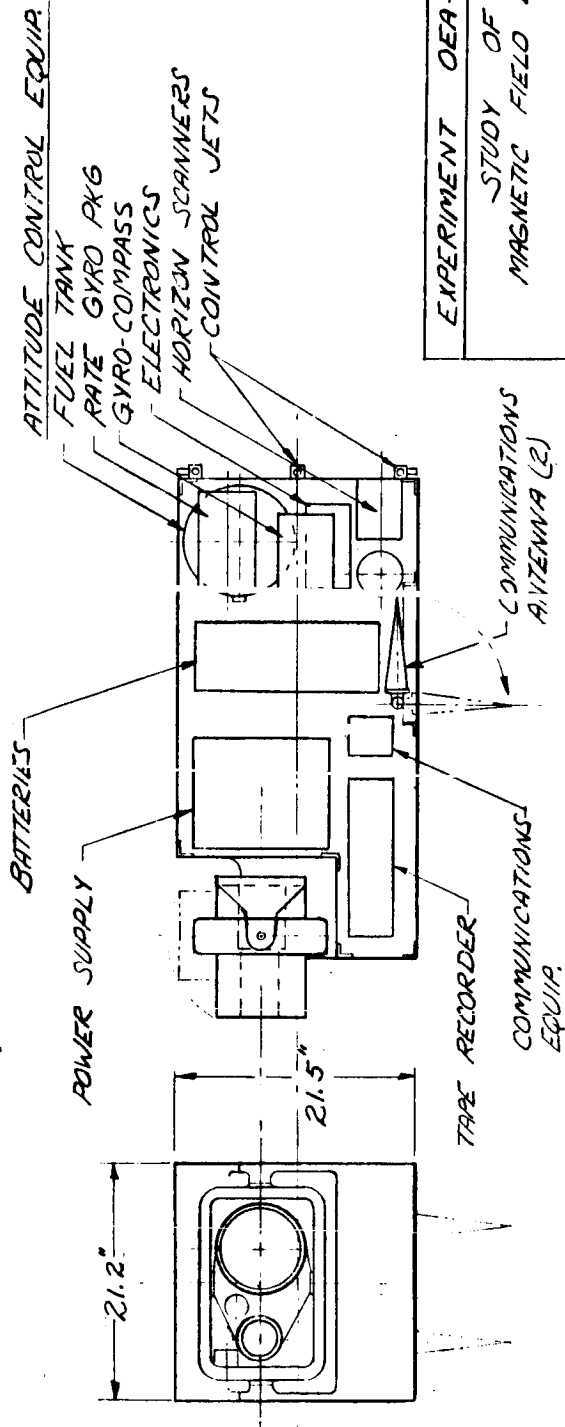
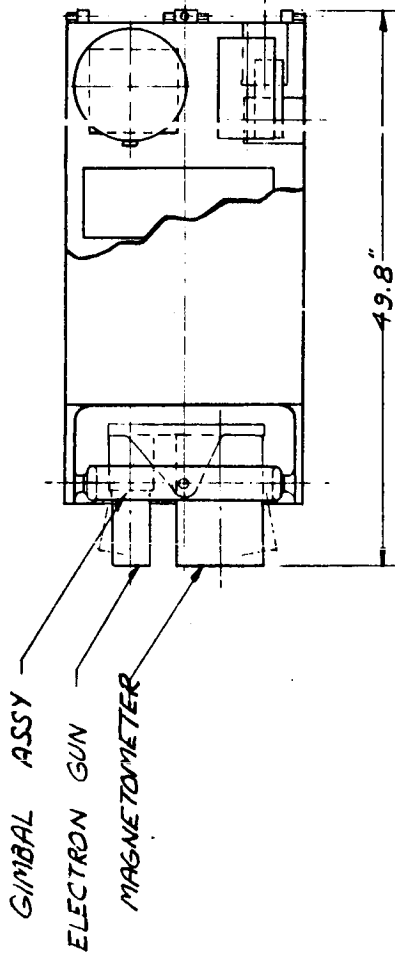

EXPERIMENT OEA-2

STUDY OF  
 MAGNETIC FIELD LINES

1/10 SIZE

9-30-65

Barrow

Figure A. 6-2 OEA-2 CONCEPTUAL DESIGN DRAWING

1. EXPERIMENT OEA-3: Test of Prototype Star Tracker
2. TECHNICAL AREA/APPLICATIONS:
  - 2.1 GENERAL AREA: Observations of the Earth's Atmosphere, the Space Environment, and Astronomical Phenomena.
  - 2.2 EXPERIMENT APPLICATIONS: To demonstrate the ability of a star-tracker to lock on and track stars of the fourth magnitude when viewed near the horizon, beneath the airglow layer.
3. EXPERIMENT OBJECTIVES AND SCOPE:
  - 3.1 OBJECTIVES:
    - a. Specific Objective: To demonstrate the ability of a prototype star-tracker to lock on and track stars of the fourth magnitude when viewed near the horizon, beneath the air-glow layer. From these data it will be possible to determine the feasibility of and test the concept of interferred atmospheric vertical pressure distribution.
    - b. Key Techniques: The star-tracker would search for and acquire stars of the fourth magnitude below the air-glow maximum, and the star would then be tracked during occultation by the Earth (and atmosphere). The vertical pressure distribution within the atmosphere would be derived from the measurement of atmospheric refraction of the starlight during occultation.
  - 3.2 MEASUREMENTS AND DATA:
    - a. Phenomena to be Observed: The phenomenon to be measured is the refraction angle of starlight. The actual measurement will be of the observed angle of the star from a reference axis as a time function. The calculated angle for the apparent movement of the star without refraction will be

subtracted from the actual measurement, thus yielding a refraction angle that will be transformed to be position-dependent, or more explicitly, dependent upon the pressure gradient in the Earth's atmosphere. The spacecraft's motion will cause the stars to set beyond the limit of the Earth. The view of the star will be acquired as it appears just beneath the brightest air-glow, at a tangent ray height of about 60 to 70 km. The star will then be tracked during occultation. The angle that will actually be measured will be between the selected occulted star and a reference star about 20 degrees above it. The reference starlight will not be refracted; therefore, the angular separation between the stars will indicate the refraction of the occulted star.

- b. Measurement Rate, Accuracy: The reference axes would have to be provided by a stable platform or by use of stellar monitors. It is possible that this experiment can be conducted during a primary astronomical measurement or any other in which it is required to know or fix reference axes in space. The motion of the star must be resolved to about one arc second and measured with a RMS error of several arc seconds. Two measurements per second are required. About 40 seconds will be required for one occultation (the amount of time is dependent upon orbital parameters).

### 3.3 FLIGHT REGIME:

- a. Orbital Parameters: Orbital altitude: 200 to 800 nautical miles.  
  
Inclination: 20 to 90 degrees.
- b. Duration: One minute.
- c. Seasonal Requirements: None
- d. Other Flight Characteristics: None

- e. Reasons: Star must "set" behind Earth's limb.

#### 3.4 SUPPORT EXPERIMENTATION:

- a. Simultaneous Activity: None
- b. Prerequisite Experimentation: None

#### 4. OPERATIONS:

##### 4.1 DUTY CYCLE:

- a. Operational Periods: Total of about six readings, about one minute each.
- b. Interval: Once per four orbits.

##### 4.2 CREW REQUIREMENTS:

- a. Astronaut Participation: Astronaut participation is not absolutely essential to the accomplishment of the task; however, the reliability and accuracy of the experiment will be enhanced because of his participation.
- b. Crew Involvement: Check operation and possibly install telescope on stable platform. Using a built-in light source, check electronic display and recording. Start sequence at proper time by turning on equipment and locating selected star.
  - (1) Setup and checkout: 9 minutes.
  - (2) Experimentation: 1 minute.

#### 5. APPARATUS DESCRIPTION:

##### 5.1 METHODS OF MEASUREMENT AND SENSOR DESCRIPTION:

- a. Equipment Name: Prototype star tracker
- b. Equipment Size Stored: 4-inch diameter x 14-inch length.
- c. Equipment Size Operating: 3-inch diameter x 12-inch length.
- d. Equipment Weight: 15 pounds.

- e. Power Requirements: 5 watts during operation (5 minutes) none at other times.
- f. Environmental Considerations: None
- g. Frequency Spectrum: N/A.
- h. Accuracy Considerations: Position of star to reference star - one arc second.
- i. Pointing Accuracy Considerations: Stable platform to within 0.5 degrees for each axis.
- j. Development Status: Components are state-of-the-art; would require approximately 6 months to assemble and test instrument.
- k. Reliability: 98 percent.

5.2 DATA COLLECTION:

- a. Format: Data will be collected on magnetic tape and transmitted to Earth (may be transmitted directly if possible).
- b. Amount: 4000 bits/experiment.
- c. Recovery Advantages: If the instrument package were recovered, it would be reusable on a future mission.

5.3 ANCILLARY EQUIPMENT: On-board tape storage of data. Test and calibration equipment will be built into the operational instrument.

6. CONCEPTUAL DESIGN: See Figure A.6-3.



NOTES

1. VOLUME (IN<sup>3</sup>)  
 BASIC COMPONENTS 6838  
 INSTALLED 17,512
2. TOTAL MASS — 378 LBS.
3. CRITICAL COMPONENT SHAPE  
 5 IN. X 11 IN. X 14 IN
4. EXPERIMENT TO BE EJECTED FROM  
 LAUNCH VEHICLE INTO EARTH ORBIT
5. ANTENNAS TO BE EXTENDED IN ORBIT
6. DURATION OF EXPERIMENT - 5 DAYS

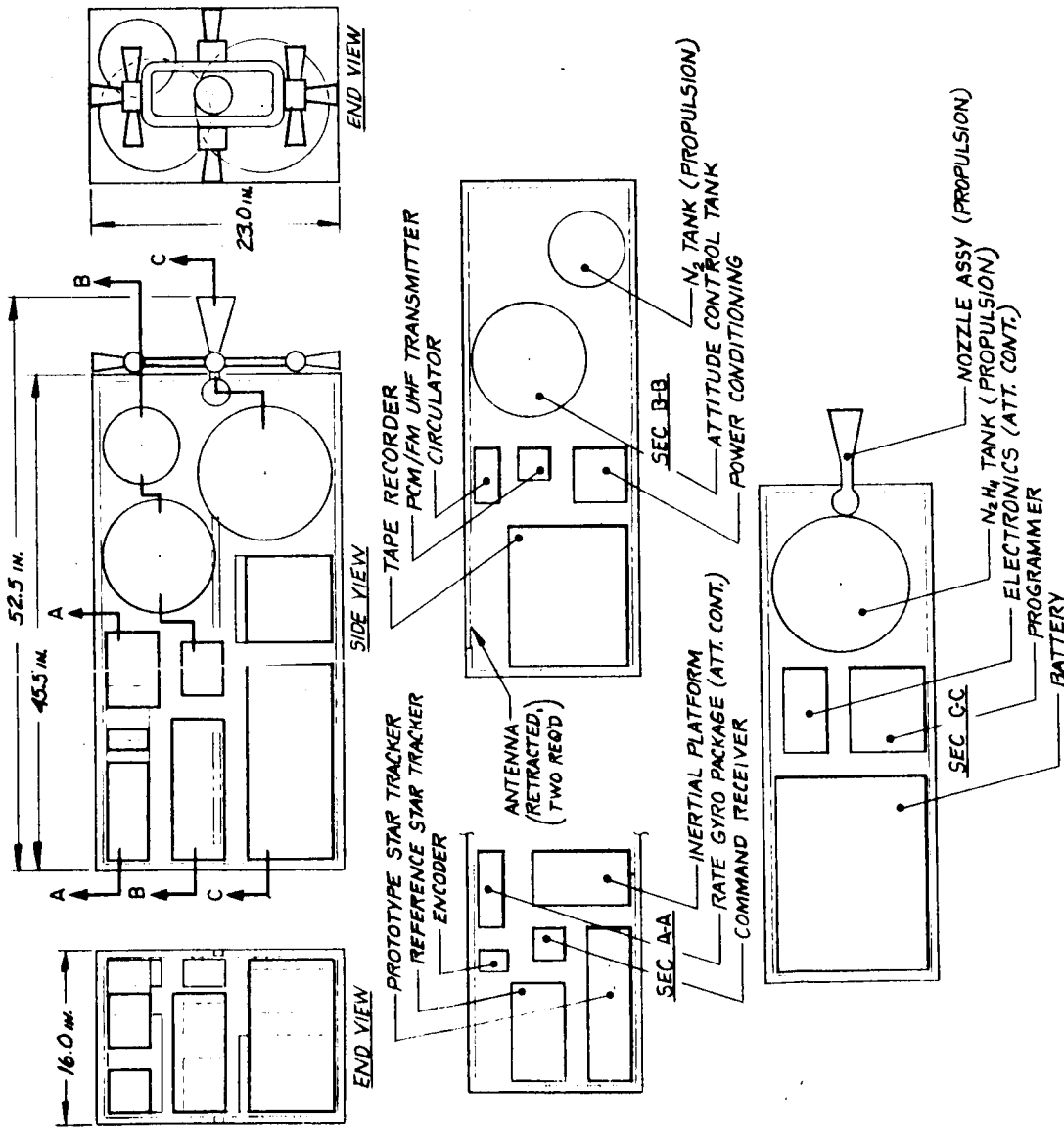

EXPERIMENT OEA-3

TEST OF PROTOTYPE  
 STAR TRACKER

1/10 SCALE B.J.CSASZAR 10-12-65

Figure A. 6-3 OEA-3 CONCEPTUAL DESIGN DRAWING

1. EXPERIMENT OEA-4: Cosmic-Ray Emulsion
2. TECHNICAL AREA/APPLICATIONS:
  - 2.1 GENERAL AREA: Observations of the Earth's atmosphere, the Space Environment, and Astronomical Phenomena.
  - 2.2 EXPERIMENT APPLICATIONS: To detect and measure the intensity and angular distribution of primary cosmic rays.
3. EXPERIMENT OBJECTIVES AND SCOPE:
  - 3.1 OBJECTIVES:
    - a. Specific Objective: To obtain a charge spectrum of the primary cosmic radiation and, indirectly, a measure of the intensity and angular distribution at several times in the solar cycle.
    - b. Key Techniques: The experiment outlined above is to be carried out with a nuclear emulsion package less than two liters in size, weighing about ten to fifteen pounds, and consisting of emulsions of various sensitivities. Additional equipment for preparing the emulsions for exposure may be required on the space station. Unless the nuclear emulsions could be returned to Earth in a week or two, it would be necessary to perform at least the initial phases of development in flight. The astronaut will assemble the emulsions in the pack, extend the pack when the satellite is properly oriented, retrieve the emulsions, and terminate the emulsion sensitivity by initiating development.
  - 3.2 MEASUREMENTS AND DATA:
    - a. Phenomena to be Observed: The phenomena to be observed are primary cosmic rays and gamma rays. The cosmic rays and the secondary electron pairs from the gamma rays will leave tracks in the nuclear emulsions which will be developed and analyzed in accordance with standard procedures.

OEA-4  
(Sheet 2)

The types of measurements to be made include space angle, grain density, secondary electron density, mean angle of deflection, and the solid angle factor.

- b. Measurement Rate, Accuracy: For the experiment, the detector need only be oriented within a cone with a half angle of 40 degrees centered about the vertical. The experiment is performed once on any given flight, with exposure going for as long as practical, up to two weeks. A period as short as two hours, however, would be worthwhile.

3.3 FLIGHT REGIME:

- a. Orbital Parameters: As low as possible; at least below 230 km at apogee. Inclination: Not equatorial.
- b. Duration: At least 2 hours, and as long as 2 weeks.
- c. Seasonal Requirements: None.
- d. Other Flight Characteristics: None
- e. Reasons: The orbit must avoid the Van Allen belt radiation.

3.4 SUPPORT EXPERIMENTATION:

- a. Simultaneous Activity: None.
- b. Prerequisite Experimentation: None

4. OPERATIONS:

4.1 DUTY CYCLE:

- a. Operational Periods: The emulsions will be exposed for at least two hours and may be exposed for as long as two weeks.
- b. Interval: Experiment is performed once per mission.

4.2 CREW REQUIREMENTS:

- a. Astronaut Participation: Astronaut participation is essential to prepare the emulsions for exposure and to desensitize the exposed emulsions.
- b. Crew Involvement: To prepare the emulsions in the pack, 0-60 minutes; to place the pack in observing position after orienting the vehicle, 20 minutes; to initiate development to desensitize the emulsions, 20 minutes.

5. APPARATUS DESCRIPTION:

5.1 METHODS OF MEASUREMENT AND SENSOR DESCRIPTION

- a. Methods of Measurement: A stack of nuclear emulsions pellicles would be exposed during periods of preselected vehicle orientation. This orientation may be required for accomplishment of a primary mission. Upon completion of the experiment, the emulsion is desensitized and stored and returned to Earth for complete development and analysis.
- b. Sensor Description:
  - (1) Equipment name: Cosmic- and Gamma-Ray Emulsion Pack
  - (2) Equipment size stored: 3 liters (with associated equipment)
  - (3) Equipment size deployed: 2 liters
  - (4) Equipment weight: 20 pounds.
  - (5) Power requirements: None
  - (6) Environmental considerations: 35-75°F
  - (7) Frequency spectrum: N/A
  - (8) Accuracy considerations: N/A

OEA-4  
(Sheet 4)

- (9) Pointing accuracy considerations:  $\pm 1$  degree
- (10) Development status: State-of-the-art
- (11) Reliability: 99 percent

5.2 DATA COLLECTION

- a. Format: Nuclear emulsion pack
- b. Amount: One pack per mission; mission duration variable from 2 hours to 2 weeks.
- c. Recovery Advantages: The pack must be recovered and returned to Earth.

5.3 ANCILLARY EQUIPMENT: The on-board equipment will consist of an emulsion holder and the necessary equipment (chemicals) to desensitize the emulsions.

6. CONCEPTUAL DESIGN: See Figure A.6-4.

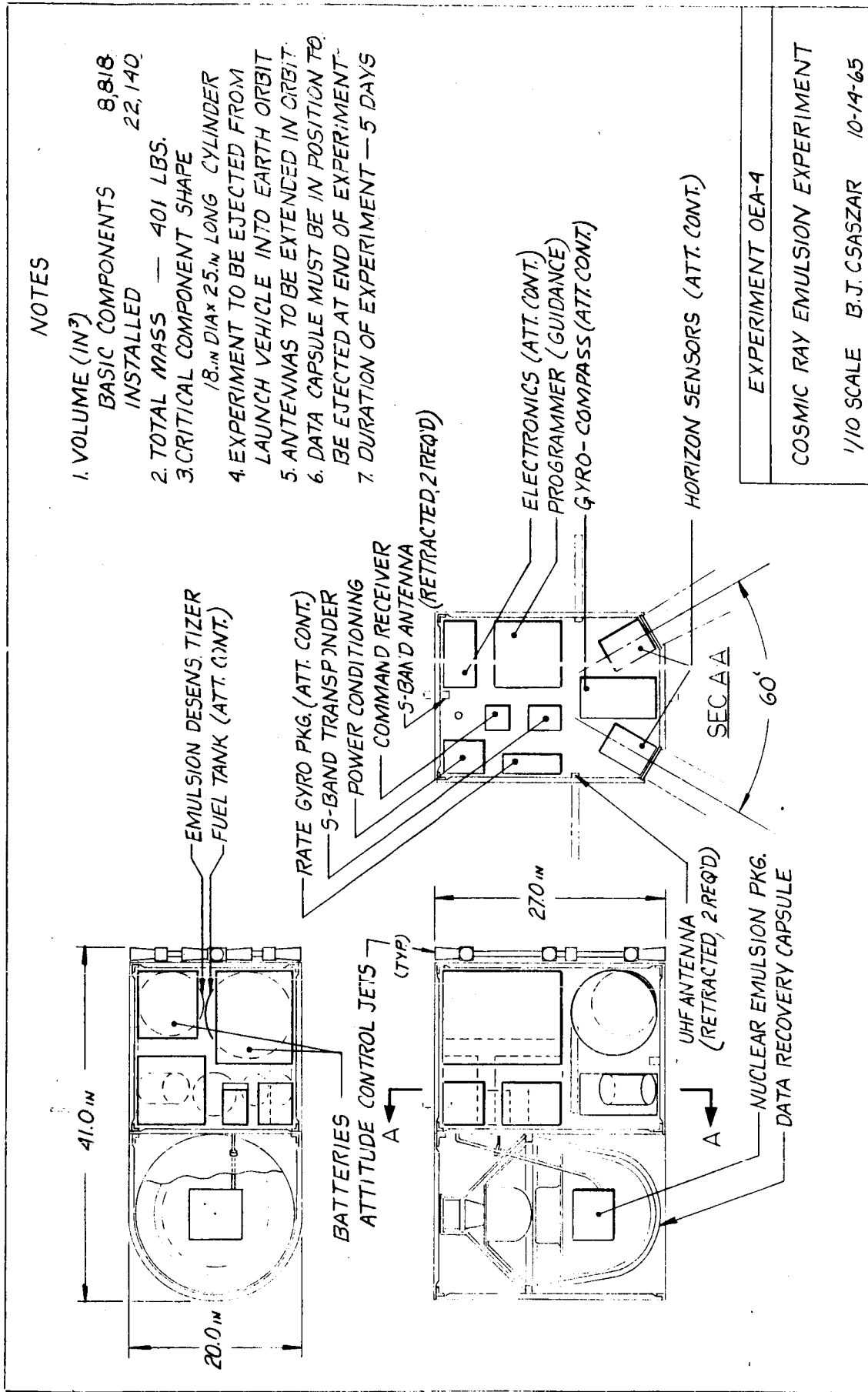

Figure A. 6-4 OEA-4 CONCEPTUAL DESIGN DRAWING

1. EXPERIMENT OEA-5: Emission Line Radiometry
2. TECHNICAL AREA/APPLICATIONS:
  - 2.1 GENERAL AREA: Observations of the Earth's Atmosphere the Space Environment, and Astronomical Phenomena.
  - 2.2 EXPERIMENT APPLICATIONS: To determine the density distribution patterns of interstellar gas. This work will have application to analysis of the evolution and processes of galaxies and stars.

3. EXPERIMENT OBJECTIVES AND SCOPE:

- 3.1 OBJECTIVES:

- a. Specific Objective: This experiment will seek to determine the density distribution patterns of interstellar gas. Since hydrogen is considered to be, by far, the major constituent of this medium, spectral analysis at the prescribed low-energy levels and consequent long wavelength will be concentrated in the IR regime. The requirements associated with this measurement suggest the use of an interferometer technique because of its ability to afford optimum performance over broad ranges of the IR spectrum.
- b. Key Techniques: The mapping of the density distribution of interstellar gas is of importance in ascertaining the physical processes occurring in space and, possibly, in providing some indication of the origins of the galaxies and stars.

The investigation may also include the detection of other elements, such as Helium and Oxygen, in the IR region.

- 3.2 MEASUREMENTS AND DATA:

- a. Phenomena to be Observed: The amplitude of an a-c modulated signal from the detector

instrument will be measured. The strength of this signal will be dependent upon the strength of an isolated spectral line associated with the interstellar gas.

- b. Measurement Rate, Accuracy: The measurements may be taken continuously with an approximate accuracy of five percent.

### 3.3 FLIGHT REGIME:

- a. Orbital Parameters: The observation of certain areas of the celestial sphere will have more interest than others. The inclusion of the galactic plane (of the Milky Way) should be included in the orbit.
- b. Duration: There is no set duration, but the entire celestial sphere should eventually be mapped for several spectral windows. The measurements may thus be taken for the duration of the mission.
- c. Seasonal Requirements: None
- d. Other Flight Characteristics: None
- e. Reasons: The galactic plane will have a higher concentration of interstellar gas than other areas of the celestial sphere.

### 3.4 SUPPORT EXPERIMENTATION:

- a. Simultaneous Activities: OAO data may contribute background material for this experiment.
- b. Prerequisite Experimentation: None

## 4. OPERATIONS:

### 4.1 DUTY CYCLE:

- a. Operational Periods: Approximately one 20-minute period every second day for duration of the mission.



4.2 CREW REQUIREMENTS:

- a. Astronaut Participation: Enhance and/or optimize performance of instruments by adjustment and/or modification to suit requirements (change filters and mirror spacings).
- b. Crew Involvement: An astronaut will perform a change of the filters in the instrument to vary the spectral window.

5. APPARATUS DESCRIPTION:

5.1 METHODS OF MEASUREMENT AND SENSOR DESCRIPTION:

- a. Methods of Measurement: The measurement of a weak emission or absorption line in the visible or infrared in the presence of a strong background continuum can be accomplished using the channel spectrum of a Michelson interferometer-spectrometer in conjunction with an optical telescope. For unequal arm spacing, the transmission of a Michelson interferometer is a cosine squared function of the path difference. By oscillating one of the interference mirrors sinusoidally with an amplitude sufficient to oscillate the transmission channels approximately one-half of a channel spacing, the weak spectral line is modulated at the frequency of oscillation whereas the background is effectively unmodulated. The signal can then be coherently detected using the mirror driving signal as reference. The sharp line must first be isolated by a narrow band (10A) interference filter. Details of line structure are not obtained.

The experiment procedure is as follows:

- (1) Radiation incident on the telescope is directed to the interferometer. A sweep generator controls the movable mirror of the interferometer.

OEA-5  
(Sheet 4)

- (2) The detector, cryogenically cooled, senses changes in the fringe pattern and sends this signal (interferogram) to an amplifier.
- (3) The amplifier output is sent to a tape recorder where it is stored.
- (4) The tape or the signal from the tape is sent to Earth for data reduction. During the signal acquisition the interferogram can be monitored by the astronaut by earphones.

b. Sensor Description:

- (1) Equipment name: Interferometer-telescope
- (2) Equipment size stored: 15-inch diameter x 20-inch length, tubular
- (3) Equipment size operating: 15-inch diameter x 20-inch length, tubular
- (4) Equipment weight: 90 pounds.
- (5) Power requirements: 50 watts for 30 minutes for each measurement (none when not performing measurement).
- (6) Environmental considerations: Unpressurized; vibration tolerance is essentially none allowable; temperature requirement is not critical for the instrument as a whole; however, the detectors will have to be cryogenically cooled.
- (7) Frequency spectrum:  $0.4\mu$  to  $40\mu$
- (8) Accuracy considerations: 5 percent
- (9) Pointing accuracy considerations:  $\pm 2^\circ$  of arc about each axis. (Note: The instrument will not have to be pointed to this accuracy, but this is the accuracy relating to where the instrument is pointing.)

OEA-5  
(Sheet 5)

(10) Development Status: This type of instrument used from a space platform is presently in the development stage. The JPL is in the process of development of a similar instrument for its lunar-interplanetary programs.

(11) Reliability: 95 percent

c. Associated Equipment:

(1) Equipment name: Accessory electronics and data storage.

(2) Equipment size stored: 8 x 8 x 10 inches

(3) Equipment size operating: 8 x 8 x 12 inches

(4) Equipment weight: 12 pounds

(5) Power requirements: Included in above.

(6) Environmental conditions: Unpressurized; temperature requirements will be that for normal electronic components.

(7) Frequency spectrum: N/A

(8) Accuracy consideration: N/A

(9) Pointing accuracy consideration: N/A

(10) Development status: Available, only adaptive development required.

(11) Reliability:

5.2 DATA COLLECTION:

a. Format: Magnetic tape information telemetered to Earth.

b. Amount: 30,000 bits/orbit

OEA-5  
(Sheet 6)

- 5.3 ANCILLARY EQUIPMENT: Tape Recorder. Astronaut monitoring device (earphones).
6. CONCEPTUAL DESIGN: See Figure A.6-5.

NOTES

1. VOLUME (IN<sup>3</sup>)  
 BASIC COMPONENTS 12,456  
 INSTALLED 31,870
2. TOTAL MASS (LBS)  
 CRITICAL COMPONENT SHAPE 69
3. CRITICAL COMPONENT SHAPE  
 15. IN. DIA. X 20. IN.
4. ENTIRE EXPERIMENT PACKAGE  
 TO BE EJECTED FROM LAUNCH  
 VEHICLE INTO EARTH ORBIT

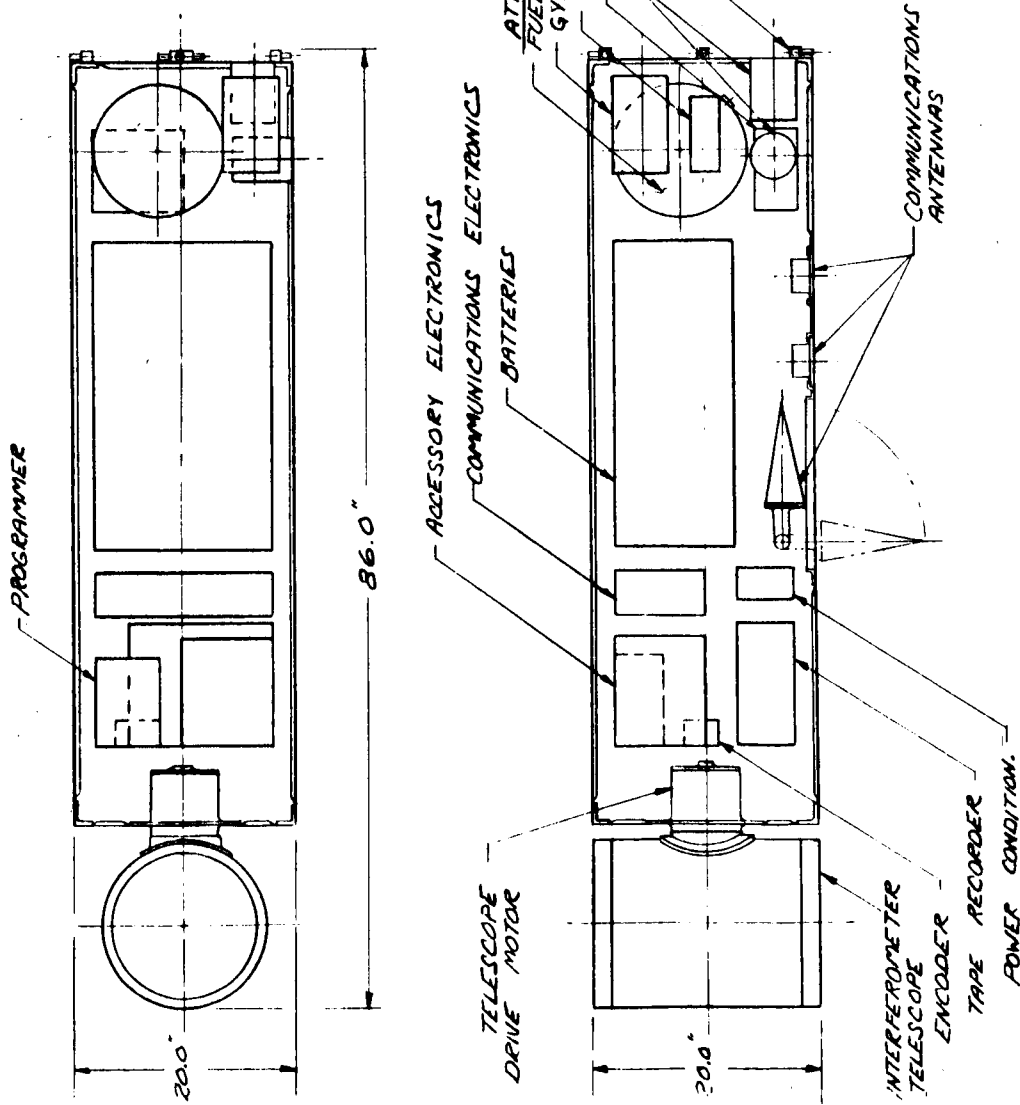

EXPERIMENT OEA-5
EMISSION LINE RADIOMETRY
1/10 SIZE 10-7-65 <i>Barman</i>

Figure A. 6-5 OEA-5 CONCEPTUAL DESIGN DRAWING

## A P P E N D I X B

### E X P E R I M E N T M A S S S U M M A R I E S

This appendix contains mass summaries for 29 of the 30 experiments described in Appendix A. Each summary is a tabulation of the total installed mass of a particular experiment. A summary for Experiment SDT-5 is not included because it is assumed to be an existing, self-contained satellite that will be launched into orbit from the parent vehicle.

MASS SUMMARY  
EXPERIMENT SDT-1

<u>ITEM</u>	<u>MASS-LBS</u>
Experiment Equipment	186.0
Data Automation	29.0
Attitude Control	118.0
Communications	12.3
Power Supply	336.0
Environmental Control	36.0
Propulsion	91.8
Destruct System	7.0
Satellite Structure	<u>121.0</u>
TOTAL MASS EXPERIMENT PACKAGE	937.1
Installation and Ejection Hardware	<u>94.0</u>
TOTAL INSTALLED MASS	1031.1

MASS SUMMARY  
EXPERIMENT SDT-2

<u>ITEM</u>		<u>MASS-LBS</u>
Experiment Equipment		14.6
Solar Collector	14.4	
Standard Cells	0.2	
Data Automation		2.0
Encoder	2.0	
Communications		7.0
Command Receiver	2.5	
PCM/FM Transmitter	2.5	
Antenna Assembly	2.0	
Power Supply		10.5
Battery	9.3	
Power Conditioning	1.2	
Environmental Control		3.0
Propulsion		9.0
Satellite Structure		<u>6.9</u>
TOTAL MASS EXPERIMENT PACKAGE		53.0
Installation and Ejection Hardware		<u>5.3</u>
TOTAL INSTALLED MASS		58.3



MASS SUMMARY  
EXPERIMENT SDT-3

<u>ITEM</u>		<u>MASS-LBS</u>
Experiment Equipment		230.0
Star Tracker	25.0	
Planet Tracker	25.0	
Tracker Electronics	20.0	
Automatic Sextant	20.0	
Sextant Electronics	20.0	
Experiment Control Computer	30.0	
Inertial Measuring Unit	25.0	
I.M.U. Electronics	20.0	
Horizon Scanner	15.0	
Digital Computer	30.0	
Communications/Data Automation		30.1
Encoder	2.0	
Tape Recorder (incl. Tape)	16.0	
Command Receiver	2.5	
PCM/FM Transmitter	2.5	
S-Band Transponder	4.5	
UHF Antenna (2 required)	0.8	
Circulator	1.0	
S-Band Antenna (2 required)	0.8	
Power Supply		221.9
Fuel Cell Module & Controls	50.0	
Radiator	7.2	
Coolant & Piping	7.2	
Hydrogen Fuel Tank	32.0	
Hydrogen Fuel	9.5	
Oxygen Fuel Tank	24.0	
Oxygen Fuel	76.0	
Power Conditioning	8.0	
Distribution	8.0	
Attitude Control		52.0
Control Moment Gyro	15.7	
Rate-Gyro Package	4.8	
Electronics	7.5	
Thrusters	1.5	
Piping/Miscellaneous	2.5	
Propellant Tank	12.5	
Propellant	7.5	
Structure		100.0
Environmental Control		<u>1.5</u>
TOTAL MASS EXPERIMENT PACKAGE		635.5
Installation and Ejection Hardware		<u>46.0</u>
TOTAL INSTALLED MASS		681.5

MASS SUMMARY  
EXPERIMENT SDT-4

<u>ITEM</u>		<u>MASS-LBS</u>
Experiment Equipment		84.0
Sun Sensor	2.0	
LH <sub>2</sub> Tank	56.0	
Superinsulation	8.0	
Instrumentation	5.0	
Ullage Control	13.0	
Data Automation		19.0
Encoder	2.0	
Tape Recorder	17.0	
Attitude Control		50.0
Communications		12.0
Power Supply		211.0
Environmental Control		10.0
Satellite Structure		<u>57.0</u>
TOTAL MASS EXPERIMENT PACKAGE		443.0
Installation and Ejection Hardware		<u>44.0</u>
TOTAL INSTALLED MASS		487.0

MASS SUMMARY  
EXPERIMENT MS-1

<u>ITEM</u>		<u>MASS-LBS</u>
Experiment Equipment		20.0
Material Samples (16)	6.0	
Deployment Motor (2)	4.0	
Belts and Pulleys	5.0	
Programmer	5.0	
Communications		9.6
Command Receiver	2.5	
Command Receiver Clock	1.0	
S-Band Transponder	4.5	
Antennas	1.6	
Data Automation		23.0
Tape Recorder and Tape	21.0	
Encoder	2.0	
Attitude Control		95.3
Sun Sensor (2)	6.0	
Rate-Gyro	4.8	
Electronics	7.5	
Thrusters	1.5	
Piping	2.5	
Fuel Tank and Fuel	73.0	
Fuel Cell Power Supply		178.9
Module and Controls	68.0	
Radiator	7.2	
Coolant and Piping	7.2	
H <sub>2</sub> Tank	21.5	
O <sub>2</sub> Tank	57.0	
Power Conditioning	9.0	
Distribution	9.0	
Satellite Structure		94.0
Data Recovery Capsule		300.0
Environmental Control		<u>2.0</u>
 TOTAL MASS EXPERIMENT PACKAGE		 722.8
 Installation and Ejection Hardware		 <u>72.0</u>
 TOTAL INSTALLED MASS		 794.8

MASS SUMMARY  
EXPERIMENT MS-2

<u>ITEM</u>		<u>MASS-LBS</u>
Liquid Film Sensor		12.0
Data Automation		23.0
Encoder	2.0	
Tape Recorder	16.0	
Programmer	5.0	
Communications		12.3
Power Supply		41.0
Environmental Control		1.0
Structural Installation		<u>13.3</u>
TOTAL INSTALLED MASS		102.6

MASS SUMMARY  
EXPERIMENT MS-3

<u>ITEM</u>		<u>MASS-LBS</u>
Experiment Equipment		11.0
Molten Metal Vaporization Sensors	11.0	
Power Supply		82.0
Batteries	70.0	
Power Conditioning	6.0	
Distribution	6.0	
Communications		12.3
Command Receiver	2.5	
PCM/FM Transmitter	2.5	
S-Band Transponder	4.5	
Combination UHF/S-Band Antennas (2)	1.8	
Circulator	1.0	
Data Automation		28.0
Programmer	5.0	
Tape Recorder	21.0	
Encoder	2.0	
Structural Installation		20.0
Environmental Control		<u>1.0</u>
<b>TOTAL INSTALLED MASS</b>		<b>154.3</b>

MASS SUMMARY  
EXPERIMENT MS-4

<u>ITEM</u>		<u>MASS-LBS</u>
Cold Weld Sensor		49.0
Data Automation		28.0
Programmer	5.0	
Tape Recorder	21.0	
Encoder	2.0	
Communications		10.5
Power Supply		60.0
Environmental Control		3.0
Structural Installation		<u>22.0</u>
TOTAL INSTALLED MASS		172.5

MASS SUMMARY  
EXPERIMENT MS-5

<u>ITEM</u>		<u>MASS-LBS</u>
Experiment Equipment		27.0
Spray and Sensor Unit "A"	22.0	
Sensor Unit "B"	5.0	
Data Automation		28.0
Programmer	5.0	
Tape Recorder	21.0	
Encoder	2.0	
Communications		10.5
Power Supply		50.0
Environmental Control		2.0
Structural Installation		<u>17.5</u>
TOTAL INSTALLED MASS		135.0

MASS SUMMARY  
EXPERIMENT MI-1

<u>ITEM</u>		<u>MASS-LBS</u>
Experiment Equipment		115.0
Multiband Camera	25.0	
Color Cameras	30.0	
Wide Angle Camera	10.0	
Stereo Cameras	30.0	
Spectroradiometers	15.0	
V/H Sensor	5.0	
Data Automation		76.0
Programmer	25.0	
Tape Recorder	16.0	
Tape and Film	30.0	
Data Transfer	5.0	
Attitude Control		58.0
Communications		12.1
Power Supply		405.0
Data Recovery Capsule (2)		160.0
Environmental Control		7.5
Satellite Structure		<u>150.0</u>
 TOTAL MASS EXPERIMENT PACKAGE		 983.6
 Installation and Ejection Hardware		 <u>98.0</u>
 TOTAL INSTALLED MASS		 1081.6



MASS SUMMARY  
EXPERIMENT MI-2

<u>ITEM</u>	<u>MASS-LBS</u>
IR Line Scanner	100.0
Data Automation	120.0
Video Tape Recorder	95.0
Programmer	25.0
Attitude Control	58.0
Horizon Sensors (2)	6.0
Control Moment Gyro	15.7
Rate Gyro	4.8
Thrusters and Piping	4.0
Electronics	7.5
Fuel. Tank and Fuel	20.0
Communications	17.1
S-Band Beacon	4.5
S-Band Transmitter	7.0
Command Receiver	2.5
Antennas	3.1
Power Supply	378.0
Batteries	348.0
Power Conditioning	15.0
Wiring and Interconnection	15.0
Environmental Control	35.5
Satellite Structure	<u>106.0</u>
TOTAL MASS EXPERIMENT PACKAGE	814.6
Installation and Ejection Hardware	<u>81.0</u>
TOTAL INSTALLED MASS	895.6

MASS SUMMARY  
EXPERIMENT MI-3

<u>ITEM</u>	<u>MASS-LBS</u>
Experiment Equipment	255.0
SLR Antenna	100.0
SLR Transmitter	80.0
SLR Receiver	30.0
Distribution and Control	35.0
Waveguides or Coax	10.0
Data Automation	271.0
Data Processor	150.0
Video Tape Recorder & Tape	96.0
Programmer	25.0
Communications	17.1
Command Receiver	2.5
S-Band Transponder	4.5
S-Band Telemetry	7.0
Antennas	3.1
Fuel Cell Power Supply	445.0
Module and Controls	187.0
Radiator	62.5
Coolant and Piping	62.5
H <sub>2</sub> Tank	23.0
O <sub>2</sub> Tank	80.0
Power Control	30.0
Attitude Control	124.0
Horizon Sensors (2)	6.0
Control Moment Gyro	15.7
Rate Gyro	4.8
Thrusters	1.5
Piping	2.5
Attitude Control Electronics	7.5
Fuel Tank and Fuel	86.0
Satellite Structure	162.0
Environmental Control	<u>36.0</u>
TOTAL MASS EXPERIMENT PACKAGE	1310.1
Installation and Ejection Hardware	<u>124.0</u>
TOTAL INSTALLED MASS	1434.1

MASS SUMMARY  
EXPERIMENT MI-4

<u>ITEM</u>	<u>MASS-LBS</u>
Experiment Equipment	155.0
Finder Tracker	25.0
Camera	40.0
Telescope	50.0
Welding Mirror	40.0
Data Automation	121.0
Video Tape Recorder	96.0
Programmer	25.0
Attitude Control	96.0
Communications	16.0
S-Band Transmitter	7.0
S-Band Transponder	4.5
Command Receiver	2.5
Antennas	2.0
Power Supply	234.0
Environmental Control	19.0
Satellite Structure	<u>89.0</u>
 TOTAL MASS EXPERIMENT PACKAGE	 730.0
 Installation and Ejection Hardware	 <u>68.0</u>
 TOTAL INSTALLED MASS	 798.0

MASS SUMMARY  
EXPERIMENT MI-5

<u>ITEM</u>		<u>MASS-LBS</u>
Experiment Equipment		765.0
Frame Camera (3)	300.0	
Film Magazine (3)	75.0	
Film	330.0	
Camera Control	30.0	
Programmer	25.0	
V/H Sensor	5.0	
Communications		8.6
Command Receiver	2.5	
S-Band Transponder	4.5	
UHF Antenna	.8	
S-Band Antenna	.8	
Data Automation		23.0
Tape Recorder and Tape	21.0	
Encoder	2.0	
Attitude Control		124.0
Horizon Sensors (2)	6.0	
Control Moment Gyro	15.7	
Rate-Gyro Package	4.6	
Electronics	7.5	
Thrusters	1.5	
Piping	2.5	
Fuel Tank and Fuel	86.0	
Power Supply		321.0
Battery	297.0	
Power Conditioning	12.0	
Distribution	12.0	
Data Recovery Capsule (3)		975.0
Satellite Structure		325.0
Environmental Control		<u>20.0</u>
 TOTAL MASS EXPERIMENT PACKAGE		 2561.5
 Installation and Ejection Hardware		 <u>250.0</u>
 TOTAL INSTALLED MASS		 2811.5

MASS SUMMARY  
EXPERIMENT SLG-1

<u>MASS</u>		<u>MASS-LBS</u>
Experiment Equipment		21.0
Test Cell	2.0	
Lights	3.0	
High-Speed Camera	16.0	
Data Automation		29.0
Tape Recorder	17.0	
Encoder	2.0	
Programmer	10.0	
Communications		4.0
PCM/FM Transmitter	2.5	
Antenna	1.5	
Power Supply		27.0
Batteries	15.0	
Power Conditioning	4.0	
Wiring	8.0	
Data Recovery Capsule		80.0
Environmental Control		4.8
Structural Installation		<u>25.0</u>
TOTAL INSTALLED MASS		190.8

MASS SUMMARY  
EXPERIMENT SLG-2

<u>ITEM</u>		<u>MASS- POUNDS</u>
Experiment Equipment		28.0
Test Cells (6)	6.0	
Light	2.0	
Photometer	10.0	
Turntable and Motor	10.0	
Communications		12.3
Command Receiver	2.5	
PCM/FM Transmitter	2.5	
S-Band Transponder	4.5	
UHF Antennas	2.0	
S-Band Antennas	0.8	
Power Supply		
Batteries	84.0	97.0
Power Conditioning	7.0	
Wiring and Interconnection	6.0	
Data Automation		29.0
Tape Recorder and Tape	17.0	
Encoder	2.0	
Programmer	10.0	
Structural Installation		25.5
Environmental Control		<u>3.0</u>
 TOTAL INSTALLED MASS		 194.8

MASS SUMMARY  
EXPERIMENT SLG-3

<u>ITEM</u>	<u>MASS- POUNDS</u>
Attitude Control	42.3
Experiment Equipment	94.0
Solar Collector	50.0
Test Cells (8)	30.0
Photocell Pyrometer	4.0
Positioning Motor	10.0
Communications	8.8
Command Receiver	2.5
S-Band Transponder	4.5
Antennas	1.8
Data Automation	29.0
Tape Recorder and Tape	17.0
Encoder	2.0
Programmer	10.0
Power Supply	74.0
Battery	50.0
Power Conditioning	12.0
Wiring and Interconnection	12.0
Satellite Structure	84.0
Data Recovery Capsule	300.0
Environmental Control	<u>16.0</u>
 TOTAL MASS EXPERIMENT PACKAGE	 648.1
 Installation and Ejection Hardware	 <u>64.8</u>
 TOTAL INSTALLED MASS	 712.9

MASS SUMMARY  
EXPERIMENT SLG-4

<u>ITEM</u>		<u>MASS-LBS</u>
Experiment Equipment		35.0
Camera (3)	16.2	
Agitator	4.4	
Fluid Cells	7.8	
Lights	2.2	
Turntable and Motor	4.4	
Programmer		15.0
Power Supply		34.0
Data Recovery Capsule		80.0
Environmental Control		8.8
Structural Installation		<u>28.0</u>
TOTAL INSTALLED MASS		200.8



MASS SUMMARY  
EXPERIMENT SLG-5

<u>ITEM</u>		<u>MASS-LBS</u>
Experiment Equipment		27.0
Combustion Chamber	22.0	
Fuel Tank	5.0	
Communications		12.3
S-Band Transponder	4.5	
Command Receiver	2.5	
PCM/FM Transmitter	2.5	
Antennas	2.8	
Power Supply		72.0
Batteries	60.0	
Power Conditioning	6.0	
Wiring	6.0	
Data Automation		19.0
Tape Recorder	17.0	
Encoder	2.0	
Environmental Control		2.5
Structural Installation		<u>20.0</u>
 TOTAL INSTALLED MASS		 152.8

MASS SUMMARY  
EXPERIMENT M-1

<u>ITEM</u>	<u>MASS-LBS</u>
Experiment Equipment	40.0
Exposure Plates	5.0
Microscope	20.0
Drive Motor	5.0
Television Cameras	10.0
Power Supply	94.0
Batteries	82.0
Power Conditioning	6.0
Distribution	6.0
Communications	16.6
Command Receiver	2.5
S-Band Transponder	4.5
S-Band Telemetry	7.0
Antennas	2.6
Environmental Control	26.0
Satellite Structure	<u>36.0</u>
 TOTAL MASS <u>EXPERIMENT PACKAGE</u>	 212.6
 Installation and Ejection Hardware	 <u>20.0</u>
 TOTAL <u>INSTALLED MASS</u>	 232.6

MASS SUMMARY  
EXPERIMENT M-2

<u>ITEM</u>		<u>MASS-LBS</u>
Experiment Equipment		85.0
Microscope	20.0	
Spectrophotometer	25.0	
Gas Chromatograph	40.0	
Data Automation		12.0
T.V. Camera	10.0	
Encoder	2.0	
Communications		17.1
Command Receiver	2.5	
S-Band Transponder	4.5	
S-Band Telemetry	7.0	
Antennas	3.1	
Power Supply		29.1
Batteries	15.1	
Power Conditioning	7.0	
Wiring	7.0	
Environmental Control		1.0
Structural Installation		<u>21.0</u>
 TOTAL INSTALLED MASS		 165.2

MASS SUMMARY  
EXPERIMENT M-3

<u>ITEM</u>	<u>MASS-LBS</u>
Experiment Equipment	25.0
Test Cell	5.0
Microscope	15.0
Positioning Motor	5.0
Communications	26.6
T.V. Camera	10.0
Command Receiver	2.5
S-Band Transponder	4.5
S-Band Telemetry	7.0
Command Receiver Antenna	1.0
S-Band Antenna and Switch	1.6
Programmer	10.0
Power Supply	95.0
Batteries	80.0
Power Conditioning	7.5
Wiring and Interconnection	7.5
Satellite Structure	24.0
Environmental Control	<u>5.5</u>
 TOTAL MASS EXPERIMENT PACKAGE	 186.1
 Installation and Ejection Hardware	 <u>19.0</u>
 TOTAL INSTALLED MASS	 205.1

**MASS SUMMARY  
EXPERIMENT M-4**

<u>ITEM</u>		<u>MASS-LBS</u>
Experiment Equipment		30.0
Microscope	20.0	
Chamber	5.0	
Chamber Motor	5.0	
Data Automation		11.0
T.V. Camera	10.0	
Programmer	1.0	
Communications		17.0
Command Receiver	2.5	
S-Band Transponder	4.5	
S-Band Telemetry	7.0	
Antennas	3.0	
Power Supply		42.0
Batteries	32.0	
Power Conditioning	5.0	
Wiring	5.0	
Environmental Control		7.0
Satellite Structure		<u>16.0</u>
<b>TOTAL MASS EXPERIMENT PACKAGE</b>		<b>123.0</b>
 Installation and Ejection Hardware		 <u>12.0</u>
<b>TOTAL INSTALLED MASS</b>		<b>135.0</b>

MASS SUMMARY  
EXPERIMENT M-5

<u>ITEM</u>		<u>MASS-LBS</u>
Experiment Equipment		25.0
Tests Cells	10.0	
Photometer	10.0	
Test Cell Motor	5.0	
Data Automation		29.0
Encoder	2.0	
Programmer	10.0	
Tape Recorder	17.0	
Communications		12.0
Command Receiver	2.5	
PCM/FM Transmitter	2.5	
S-Band Transponder	4.5	
Antennas	2.5	
Power Supply		112.0
Batteries	100.0	
Power Conditioning	6.0	
Wiring	6.0	
Environmental Control		4.0
Satellite Structure		<u>27.0</u>
 TOTAL MASS EXPERIMENT PACKAGE		 209.0
 Installation and Ejection Hardware		 <u>21.0</u>
 TOTAL INSTALLED MASS		 230.0

MASS SUMMARY  
EXPERIMENT OEA-1

<u>ITEM</u>		<u>MASS-LBS</u>
Experiment Equipment		44.0
Electron Spectrometer	4.0	
Proton-Alpha Spectrometer	6.0	
Ionization Chamber	3.0	
Energy Transfer Spectrometer	3.0	
X-Ray Detector	1.0	
Gamma Ray Detector	5.0	
Neutron Detector	7.0	
Accessory Electronics	15.0	
Data Automation		36.0
Tape Recorder	17.0	
Computer	17.0	
Encoder	2.0	
Communications		4.0
PCM/FM Transmitter	2.5	
Antennas	1.5	
Power Supply		183.0
Batteries	169.0	
Power Conditioning	6.0	
Wiring	8.0	
Environmental Control		1.0
Structural Installation		<u>40.0</u>
 TOTAL INSTALLED MASS		 308.0

MASS SUMMARY  
EXPERIMENT OEA-2

<u>ITEM</u>		<u>MASS-LBS</u>
Experiment Equipment		100.0
Electron Gun		
Magnetometer		
Power Supply		
Gimbal Assembly		
Communications		7.0
Command Receiver	2.5	
PCM/FM UHF TX	2.5	
UHF Antenna System	2.0	
Tape Recorder and Tape		11.0
Power Supply		64.0
Attitude Control		50.0
Environmental Control		5.0
Satellite Structure		<u>47.0</u>
 TOTAL MASS EXPERIMENT PACKAGE		 284.0
 Installation and Ejection Hardware		 <u>28.0</u>
 TOTAL INSTALLED MASS		 312.0



MASS SUMMARY  
EXPERIMENT OEA-3

<u>ITEM</u>		<u>MASS-LBS</u>
Experiment Equipment		37.0
Prototype Star Tracker	15.0	
Reference Star Tracker	6.0	
Inertial Platform	16.0	
Data Automation		19.0
Tape Recorder	17.0	
Encoder	2.0	
Communications		7.0
Command Receiver	2.5	
PCM/FM Transmitter	2.5	
Antennas	2.0	
Attitude Control		43.0
Power Supply		130.0
Battery	120.0	
Power Conditioning	5.0	
Wiring	5.0	
Propulsion		30.0
Environmental Control		4.0
Satellite Structure		<u>74.0</u>
 TOTAL MASS EXPERIMENT PACKAGE		 344.0
 Installation and Ejection Hardware		 <u>34.0</u>
 TOTAL INSTALLED MASS		 378.0

MASS SUMMARY  
EXPERIMENT OEA-4

<u>ITEM</u>	<u>MASS-LBS</u>
Experiment Equipment	21.0
Nuclear Emulsion	15.0
Emulsion Desensitizer	6.0
Programmer	15.0
Communications	9.0
Command Receiver	2.5
S-Band Transponder	4.5
Antennas	2.0
Power Supply	137.0
Batteries	127.0
Power Distribution	5.0
Wiring	5.0
Attitude Control	50.0
Data Recovery Capsule	80.0
Environmental Control	3.5
Satellite Structure	<u>49.0</u>
 TOTAL MASS EXPERIMENT PACKAGE	 364.5
 Installation and Ejection Hardware	 <u>36.0</u>
 TOTAL INSTALLED MASS	 400.5

MASS SUMMARY  
EXPERIMENT OEA-5

<u>ITEM</u>		<u>MASS-LBS</u>
Experiment Equipment		108.0
Interferometer Telescope	90.0	
Drive Motor	6.0	
Accessory Electronics	12.0	
Data Automation		19.0
Encoder	2.0	
Tape Recorder	17.0	
Communications		12.3
Command Receiver	2.5	
PCM/FM Transmitter	2.5	
S-Band Transponder	4.5	
Antennas	2.8	
Power Supply		320.0
Battery	305.0	
Power Conditioning	7.5	
Wiring	7.5	
Attitude Control		58.0
Environmental Control		27.5
Satellite Structure		<u>87.0</u>
TOTAL MASS EXPERIMENT PACKAGE		631.8
Installation and Ejection Hardware		<u>59.0</u>
TOTAL INSTALLED MASS		690.8

## A P P E N D I X C

### D A T A A U T O M A T I O N W O R K S H E E T S

The data automation worksheets applicable to each of the six scientific and technological categories of experiments are presented herein. The volume, mass, and power required for data automation in the experiments described in Appendix A are indicated in the worksheets. Data automation requirements are not given for Experiment SDT-5 since it is assumed to be an existing, self-contained satellite that will be launched into orbit from the parent vehicle. The data automation systems are described in detail in subsection 4.3 of this report.

DATA AUTOMATION  
SYSTEMS DEVELOPMENT AND TEST

Item	Length In.	Width In.	Height In.	Volume In. <sup>3</sup>	Mass Lbs	Power Watts
SDT-1 Programmer	4	6	8	192	10	10
Encoder	4	3	2	24	2	12
Tape Recorder	13	5	11	715	16	45
Tape	-	-	-	-	1	-
TOTALS				931	29	67
SDT-2 Encoder	4	3	2	24	2	12
SDT-3 Encoder	4	3	2	24	2	12
Tape Recorder	12	8	5	480	15	15
Tape	-	-	-	-	1	-
TOTALS				504	18	27
SDT-4 Instrumentation	12	12	12	1728	5	1
Encoder	4	3	2	24	2	12
Tape Recorder	13	5	11	715	16	45
Tape	-	-	-	-	1	-
TOTALS				2467	24	58

DATA AUTOMATION  
MATERIALS AND STRUCTURES

Item	Length In.	Width In.	Height In.	Volume In. <sup>3</sup>	Mass Lbs	Power Watts	
MS-1							
Encoder	4	3	2	24	2	12	
Tape Recorder	10	14	3	420	20	22	
Tape	-	-	-	-	1	-	
Data Recovery Capsule					300	-	
				TOTALS	444	323	34
					Plus		
					D.R.C.		
MS-2							
Programmer	3	5	8	120	5	8	
Encoder	4	3	2	24	2	12	
Tape Recorder	6	6	3	108	15	20	
Tape	-	-	-	-	1	-	
				TOTALS	252	23	40
MS-3							
Programmer	3	5	8	120	5	8	
Encoder	4	3	2	24	2	12	
Tape Recorder	10	14	3	420	20	22	
Tape	-	-	-	-	1	-	
				TOTALS	564	28	42
MS-4							
Programmer	3	5	8	120	5	8	
Encoder	4	3	2	24	2	12	
Tape Recorder	6	6	3	108	20	20	
Tape	-	-	-	-	1	-	
				TOTALS	252	28	40
MS-5							
Programmer	3	5	8	120	5	8	
Encoder	4	3	2	24	2	12	
Tape Recorder	6	6	3	108	20	20	
Tape	-	-	-	-	1	-	
				TOTALS	252	28	40

DATA AUTOMATION

MULTISPECTRAL IMAGERY OF THE EARTH AND ORBITING OBJECTS

Item	Length In.	Width In.	Height In.	Volume In. <sup>3</sup>	Mass Lbs	Power Watts	
MI-1 Programmer	12	12	5	720	25	16	
Tape Recorder	13	5	11	715	16	45	
Film & Tape	-	-	-	-	30	-	
Data Transfer Equipment					5	-	
Data Recovery Capsules (2)					160	-	
				TOTALS	1435	236	61
					Plus		
					D.R.C.		
MI-2 Programmer	12	12	5	720	25	16	
Video Tape Recorder	30	18	12	5880	95	300	
				TOTALS	6600	120	316
MI-3 Data Processor	36	12	12	5184	150	750	
Programmer	12	12	5	720	25	16	
Video Tape Recorder	30	18	12	5880	95	300	
Tape	-	-	-	-	1	-	
				TOTALS	11,784	271	1066
MI-4 Programmer	12	12	5	720	25	16	
Video Tape Recorder	30	18	12	5880	95	300	
Tape	-	-	-	-	1	-	
				TOTALS	6600	121	316
MI-5 Programmer	12	12	5	720	25	16	
Encoder	4	3	2	24	2	12	
Tape Recorder	10	14	3	420	20	22	
Tape	-	-	-	-	1	-	
Data Recovery Capsules (3)					975	-	
				TOTALS	1164	1023	50
					Plus		
					D.R.C.		

DATA AUTOMATION  
SOLID/LIQUID/GAS BEHAVIOR

Item	Length In.	Width In.	Height In.	Volume In. <sup>3</sup>	Mass Lbs	Power Watts
SLG-1						
Programmer	4	6	8	192	10	10
Encoder	4	3	2	24	2	12
Tape Recorder	13	5	11	715	16	45
Tape & Film	-	-	-	-	2	-
Data Recovery Capsule					80	
				TOTALS	931	110
					Plus	67
					D.R.C.	
SLG-2						
Programmer	4	6	8	192	10	10
Encoder	4	3	2	24	2	12
Tape Recorder	13	5	11	715	16	45
Tape	-	-	-	-	1	-
				TOTALS	931	29
						67
SLG-3						
Programmer	4	6	8	192	10	10
Encoder	4	3	2	24	2	12
Tape Recorder	13	5	11	715	16	45
Tape	-	-	-	-	1	-
Data Recovery Capsule					300	
				TOTALS	931	329
					Plus	67
					D.R.C.	
SLG-4						
Programmer	4	6	8	192	15	10
Film (Three 100' rolls)	6 ea	6 ea	1 ea	108	3	-
Data Transfer Equipment					2	
Data Recovery Capsule					80	
				TOTALS	300	100
					Plus	10
					D.R.C.	
SLG-5						
Encoder	4	3	2	24	2	12
Tape Recorder	13	5	11	715	16	45
Tape	-	-	-	-	1	-
				TOTALS	739	19
						57



DATA AUTOMATION

MICROORGANISMS

Item	Length In.	Width In.	Height In.	Volume In. <sup>3</sup>	Mass Lbs	Power Watts	
M-1 Television Camera	7	7	16	784	10	5	
M-2 Encoder	4	3	2	24	2	12	
M-2 Television Camera	7	7	16	784	10	5	
				TOTALS	808	12	17
M-3 Programmer	4	6	8	192	10	10	
M-3 Television Camera	7	7	16	784	10	5	
				TOTALS	976	20	15
M-4 Television Camera	7	7	16	784	10	5	
M-5 Programmer	4	6	8	192	10	10	
M-5 Encoder	4	3	2	24	2	12	
M-5 Tape Recorder	13	5	11	715	16	45	
M-5 Tape	-	-	-	-	1	-	
				TOTALS	931	29	67

DATA AUTOMATION

OBSERVATIONS OF THE EARTH'S ATMOSPHERE,  
THE SPACE ENVIRONMENT, AND ASTRONOMICAL PHENOMENA

Item	Length In.	Width In.	Height In.	Volume In. <sup>3</sup>	Mass Lbs	Power Watts	
OEA-1							
Encoder	4	3	2	24	2	12	
Tape Recorder	13	5	11	715	16	45	
Tape	-	-	-	-	1	-	
Computer	8	8	12	768	17	53	
				TOTALS	1507	36	110
OEA-2							
Encoder	4	3	2	24	2	12	
Tape Recorder	14	14	4	784	10	2	
Tape	-	-	-	-	1	-	
				TOTALS	808	13	14
OEA-3							
Encoder	4	3	2	24	2	12	
Tape Recorder	13	5	11	715	16	45	
Tape	-	-	-	-	1	-	
				TOTALS	739	19	57
OEA-4							
Emulsion Desensitizer (7.5 in. dia. sphere)				221	6	-	
Programmer	8	8	5	320	15	16	
Data Recovery Capsule					80	-	
				TOTALS	541	101	16
					Plus		
					D.R.C.		
OEA-5							
Programmer	4	6	8	192	10	10	
Encoder	4	3	2	24	2	12	
Tape Recorder	13	5	11	715	16	45	
Tape	-	-	-	-	1	-	
				TOTALS	931	29	67

A P P E N D I X    D

A T T I T U D E    C O N T R O L    A S S U M P T I O N S

As indicated in subsection 4.2 of this report, experiment MI-1 (Multispectral Surveillance of Earth) was used as a reference example in order to generate parametric design data for use in sizing attitude control systems.

The physical characteristics of the reference attitude control system are estimated to be as follows:

	<u>Mass</u> <u>lb</u>	<u>Volume</u> <u>in.<sup>3</sup></u>	<u>Power</u> <u>Watt</u>
<b>FIXED EQUIPMENT</b>			
Horizon Sensors (2)	6.0	140	8
Gyro-compass	15.7	180	7
rate-gyro Package (3 gyros)	4.8	90	15
Electronics	7.5	250	15
Thrusters	1.5	-	5
Piping, miscellaneous	<u>2.5</u>	<u>-</u>	<u>-</u>
	38.0	660	50
<b>VARIABLE EQUIPMENT</b>			
Propellant Tank	12.5	905	-
Propellant	<u>7.5</u>	<u>-</u>	<u>-</u>
<b>TOTAL SYSTEM</b>	58.0	1565	50

The conservative estimate for the volume of the attitude control electronics is based on a density of 50 pounds per cubic foot. Further analysis might possibly justify reducing this volume estimate by 50 percent.

The figures for propellant and propellant tank are based on the use of a stored gas (N<sub>2</sub>) system having a useful impulse of 500 lb-sec. This impulse was selected somewhat arbitrarily as a reasonable figure for a satellite of this type. It will vary with the many system parameters, particularly lifetime. The normal procedure would be to define the required system performance and then calculate the impulse. However, the results are quite sensitive to the particular assumptions made. It appears to be more meaningful to proceed in reverse, i.e., select a reasonable result (tank size, propellant weight, etc.) and then determine what performance is obtained. This latter approach was followed.

Based on an assumed preliminary configuration and mass estimate, the following data were selected as typical for use in performance calculations:

Mass = 17.1 slugs  
 Pitch/Yaw Moment of Inertia,  $I_1 = 100 \text{ slug-ft}^2$   
 Roll Moment of Inertia,  $I_2 = 8 \text{ slug-ft}^2$   
 Moment Arms:  $l_1 = 5 \text{ ft}$ , pitch/yaw  
 $l_2 = 2.75 \text{ ft}$ , roll (couple)

Since an attitude accuracy of  $\pm 1.5$  degrees is specified for the reference experiment, the limit-cycle deadband,  $\theta_E$ , is set at this value (the sensor threshold is about  $\pm 0.5$  degree). The desired mission lifetime,  $L$ , is specified to be about 2 weeks.

The total system impulse of 500 lb-sec must be split among the three control axes. The following breakdown is assumed:

Limit-cycle Impulse:  $\text{Imp}_1 = 150 \text{ lb-sec}$ , pitch  
 $= 150 \text{ lb-sec}$ , yaw

$\text{Imp}_2 = 50 \text{ lb-sec}$ , roll

Miscellaneous, all axes: 150 lb-sec

Total 500 lb-sec

The unit pulses, average pulse spacing, and limit-cycle peak rate are determined below:

Pitch/Yaw Axes: 
$$\Delta I_1 = \left[ \frac{4(I_1)(\theta_E/57.3)(Imp_1)}{(l_1)(L \times 6.048 \times 10^5)} \right]^{\frac{1}{2}} = .0161 \text{ lb-sec}$$

$= (.32 \text{ lb for } .05 \text{ sec}) \text{ unit pulse}$

$t_1 = \frac{4(I_1)(\theta_E/57.3)}{(\Delta I_1)(l_1)} = 130 \text{ sec, average spacing}$

$\dot{\theta}_{E1} = \frac{(\Delta I_1)(l_1)}{2(I_1)} = .0004025 \text{ rad/sec, peak rate}$

Roll Axis: 
$$\Delta I_2 = \left[ \frac{2(I_2)(\theta_E/57.3)(Imp_2)}{(l_2)(L \times 6.048 \times 10^5)} \right]^{\frac{1}{2}} = .0025 \text{ lb-sec}$$

$= (.05 \text{ lb for } .05 \text{ sec}) \text{ unit pulse}$

$t_2 = \frac{4(I_2)(\theta_E/57.3)}{(\Delta I_2)(l_2)} = 122 \text{ sec, average spacing}$

$\dot{\theta}_{E2} = \frac{(\Delta I_2)(l_2)}{2(I_2)} = .00043 \text{ rad/sec, peak rate}$

The above characteristics are reasonable and indicate that the assumptions are within feasible limits. For the reference case, the limit-cycle peak rates are well below the rate at which blurring of photographic pictures would result.

The requirements at other values of pointing accuracy,  $\theta_E$ , and lifetime,  $L$ , can be obtained by a proportional change in the amount of propellant provided. The propellant mass and volume are assumed to vary directly as does the lifetime and inversely as the pointing accuracy, while the tank mass is assumed to vary directly as does the tank surface area ( $\pi d^2$ ). The reference tank is a sphere with diameter,  $d$ , equal to 12 inches. Thus, the following expressions may be written for tank diameter and total attitude control mass and volume:

$$d = 12 \left( \frac{1.5L}{2\theta_E} \right)^{1/3} \text{ inches}$$

$$\text{Total System Mass} = 38.0 + \left( \frac{1.5L}{2\theta_E} \right) (7.5) + \left( \frac{1.5L}{2\theta_E} \right)^{2/3} (12.5) \text{ pounds}$$

$$\text{Total System Volume} = 660 = \left( \frac{1.5L}{2\theta_E} \right) (288 \pi) \text{ cubic inches}$$

where: L = mission lifetime in weeks  
 $\theta_E$  = pointing accuracy in degrees

It is indicated that a stored gas system is suitable for attitude control in the case of total system impulse requirements up to 3000 lb-sec, corresponding to the ratio  $L/\theta_E = 8$  weeks per degree.

## A P P E N D I X E

### C O M M U N I C A T I O N S W O R K S H E E T S

The volume, mass, and power required for communications systems in the experiments described in Appendix A are indicated in the following worksheets. Ancillary communications systems are not required for Experiments SDT-5 and SLG-4. The communications systems are described in detail in subsection 4.4 of this report.

## SDT-1

## COMMUNICATION REQUIREMENTS

<u>Unit</u>	<u>Volume (cu in.)</u>	<u>Mass (lb)</u>	<u>Power (watt)</u>
Command Receiver	40	2.5	6
Antenna (Turnstile)	50	1.0	-
Digital UHF Transmitter	40	2.5	10
Antenna (SW)	62	1.0	-
S-Band Transponder	60	4.5	10
S-Band Antenna (turnstile - mount on same boom)	17	0.8	-
	—	—	—
TOTAL	269	12.3	26



## SDT-2

## COMMUNICATION REQUIREMENTS

<u>Unit</u>	<u>Volume (cu in.)</u>	<u>Mass (lb)</u>	<u>Power (watt)</u>
Command Receiver	40	2.5	6
PCM/FM Transmitter	40	2.5	10
Antenna Assembly	52	2.0	-
	—	—	—
TOTAL	132	7.0	16

## Remarks:

1. Satellite not stabilized; therefore, a turnstile antenna system is required.
2. PMC/FM transmitter is "OFF" until turned on by a Command Receiver signal.
3. Duty cycle limited to L.O.S. conditions with ground stations; consequently, data taken from magnetic tape storage or direct.
4. Same antenna system used for Command Receiver and PCM/FM transmitter; circulator used for isolation.
5. Because of low available power, no transponder for location included. Due to physical size, the satellite detected by radar.

## SDT-3

## COMMUNICATION REQUIREMENTS

<u>Unit</u>	<u>Volume (cu in.)</u>	<u>Mass (lb)</u>	<u>Power (watt)</u>
Command Receiver	40	2.5	6
PCM/FM Transmitter	40	2.5	10
S-Band Transponder	60	4.5	10
UHF Antenna			
1. 2 Antennas	38	0.8	-
2. 1 Circulator	50	1.0	-
S-Band Antenna			
(2 required)	17	0.8	-
	<hr/>	<hr/>	<hr/>
TOTAL	245	12.1	26

## Remarks:

1. Satellite stabilized; therefore, only two UHF and two S-Band antennas required to provide adequate lower hemisphere coverage.
2. Antennas mounted so that L.O.S. conditions with one antenna always maintained.
3. Same antenna system used for Command Receiver and PCM/FM transmitter; circulator used for isolation.

## SDT-4

## COMMUNICATION REQUIREMENTS

<u>Unit</u>	<u>Volume (cu in.)</u>	<u>Mass (lb)</u>	<u>Power (watt)</u>
Command Receiver	40	2.5	6
PCM/FM Transmitter	40	2.5	10
S-Band Transponder	60	4.5	10
UHF Antenna			
1. 2 Antennas	38	0.8	-
2. 1 Circulator	50	1.0	-
S-Band Antenna			
(2 required)	17	0.8	-
	<hr/>	<hr/>	<hr/>
TOTAL	245	12.1	26

## Remarks:

1. Satellite stabilized; therefore, only two UHF and two S-Band antennas required to provide adequate lower hemisphere coverage.
2. Same antenna system used for Command Receiver and PCM/FM transmitter; circulator used for isolation.

MS-1

COMMUNICATION REQUIREMENTS

<u>Unit</u>	<u>Volume (cu in.)</u>	<u>Mass (lb)</u>	<u>Power (watt)</u>
Command Receiver	40	2.5	6
Command Receiver Clock	27	1.0	-
S-Band Transponder	60	4.5	10
UHF Antenna	38	0.8	-
S-Band Antenna	17	0.8	-
	—	—	—
TOTAL	182	9.6	16

Remarks:

1. Satellite stabilized with respect to the Sun in order to perform the experiment.
2. All material used in the experiment recovered as well as the tape recording of the temperature variations.
3. A Command Receiver required to control the on-board programmer and initiate the recovery mode.
4. An S-Band transponder required to aid in location and tracking. However, because of the long experiment time (2 months), the transponder turned off by the Command Receiver after orbit predicted. An alternate approach: schedule on-off cycles by use of the on-board programmer.

## MS-2

## COMMUNICATION REQUIREMENTS

<u>Unit</u>	<u>Volume (cu in.)</u>	<u>Mass (lb)</u>	<u>Power (watt)</u>
Command Receiver	40	2.5	6
PCM/FM Transmitter	40	2.5	10
S-Band Transponder	60	4.5	10
UHF Antenna			
1. 2 Turnstile	62	1.0	-
2. Circulator	50	1.0	-
S-Band Antenna (2 required) (mount on same turnstile)	17	0.8	-
		—	—
TOTAL	269	12.3	26

## Remarks:

1. Satellite not stabilized; therefore, two turnstile antennas required. Same turnstile arm mounting support used for both UHF and S-Band antennas.
2. The Command Receiver required to control the timing selection for each experiment. The on-off type signals, indicative of the position of the sensor contacts, transmitted by the PCM/FM.
3. S-Band transponder required for location and tracking of the satellite.

## MS-3

## COMMUNICATION REQUIREMENTS

<u>Unit</u>	<u>Volume (cu in.)</u>	<u>Mass (lb)</u>	<u>Power (watt)</u>
Command Receiver	40	2.5	6
PCM/FM Transmitter	40	2.5	10
S-Band Transponder	60	4.5	10
UHF Antenna			
1. 2 Turnstile	62	1.0	-
2. Circulator	50	1.0	-
S-Band Antenna (2 required (mount on same turnstile))	17	0.8	-
	—	—	—
TOTAL	269	12.3	26

## Remarks:

1. Satellite not stabilized; therefore, two turnstile antennas required. Same turnstile arm mounting support used for both UHF and S-Band antennas.
2. The Command Receiver required to control the timing selection for each experiment. The on-off type signals, indicative of the position of the sensor contacts, transmitted by the PCM/FM transmitter.
3. S-Band transponder required for location and tracking of the satellite.

## MS-4

## COMMUNICATION REQUIREMENTS

<u>Unit</u>	<u>Volume (cu in.)</u>	<u>Mass (lb)</u>	<u>Power (watt)</u>
Command Receiver	40	2.5	6
UHF Digital Transmitter	40	2.5	10
UHF Circulator	6	1.0	
S-Band Transponder	60	4.5	10
Antennas (Vehicle unstable)*			
1. 3 UHF	-	-	-
2. 3 S-Band	-	-	-
	<hr/>	<hr/>	
TOTAL	146	10.5	26

\*Antennas spaced equally about the satellite to ensure communication with the Earth for all satellite positions.

## MS-5

## COMMUNICATION REQUIREMENTS

<u>Unit</u>	<u>Volume (cu in.)</u>	<u>Mass (lb)</u>	<u>Power (watt)</u>
Command Receiver	40	2.5	6
UHF Digital Transmitter	40	2.5	10
Circulator	6	1.0	-
S-Band Transponder	60	4.5	10
Antennas (Vehicle uninstalbe)8	-	-	-
1. UHF (3 minimum)			
2. S-Band (3 minimum)			
	—	—	—
TOTAL	146	10.5	26

\*Antennas spaced equally about the satellite to ensure continuous communication with the Earth for all satellite positions.



MI-1

COMMUNICATION REQUIREMENTS

<u>Unit</u>	<u>Volume (cu in.)</u>	<u>Mass (lb)</u>	<u>Power (watt)</u>
Command Receiver	40	2.5	6
Command Receiver Antenna	38	0.8	-
Analog Telemetry Transceiver	40	2.5	10
Telemetry Transceiver Antenna	62	1.0	-
S-Band Transponder	60	4.5	10
S-Band Antenna	62	0.8	-
	<hr/>	<hr/>	<hr/>
TOTAL	302	12.1	26

MI-2

COMMUNICATION REQUIREMENTS

<u>Unit</u>	<u>Volume (cu in.)</u>	<u>Mass (lb)</u>	<u>Power (watt)</u>
S-Band Beacon*	60	4.5	10
S-Band Transmitter	93	7.0	30
Command Receiver	43	2.5	6
Antennas	117	3.1	-
1. 1 Command UHF Antenna			
2. 1 S-Band Transmitter Antenna			
	—	—	—
TOTAL	313	17.1	46

\*Antenna switch only used to change from beacon to transmitter.

## MI-3

## COMMUNICATION REQUIREMENTS

<u>Unit</u>	<u>Volume (cu in.)</u>	<u>Mass (lb)</u>	<u>Power (watt)</u>
Command Receiver	40	2.5	6
S-Band Transponder	60	4.5	10
S-Band Telemetry	93	7.0	15
Antennas			
1. Command Receiver	38	0.8	-
2. S-Band Transponder (Switch)	17	0.8	-
3. S-Band Telemetry	62	1.5	-
TOTAL	310	17.1	31

## Remarks:

1. Analog data of 1 Mc taken from tape recorder.
2. Recorder and S-Band telemetry link controlled by command data from ground station.
3. Location, tracking, range and range rate information provided by S-Band transponder.
4. Timing and position and synchronization data transmitted with wideband analog data on subcarrier.
5. Satellite space stabilized; therefore, one antenna system required for S-Band transponder and S-Band telemetry; switch used to control output as directed by Command Receiver.

MI-4

COMMUNICATION REQUIREMENTS

<u>Units</u>	<u>Volume (cu in.)</u>	<u>Mass (lb)</u>	<u>Power (watt)</u>
S-Band Transmitter	93	7.0	30
S-Band Beacon	60	4.5	10
S-Band Antenna	62	1.5	-
Command Receiver	43	2.5	6
Command Receiver Antenna	38	0.8	-
	—	—	—
TOTAL	296	16.3	46

## MI-5

## COMMUNICATION REQUIREMENTS

<u>Unit</u>	<u>Volume (cu in.)</u>	<u>Mass (lb)</u>	<u>Power (watt)</u>
Command Receiver	40	2.5	6
S-Band Transponder	60	4.5	10
UHF Antenna	38	0.8	-
S-Band Antenna	17	0.8	-
	—	—	—
TOTAL	155	8.6	16

## Remarks:

1. Satellite stabilized in order to perform the photographic experiments.
2. All photographic data and auxiliary magnetic tape information physically received.
3. Command Receiver required to control the on-board programmer.
4. S-Band transponder required to aid in location and tracking of the satellite.

SLG-1

COMMUNICATION REQUIREMENTS

<u>Unit</u>	<u>Volume (cu in.)</u>	<u>Mass (lb)</u>	<u>Power (watt)</u>
PCM/FM Transmitter	40	2.5	10
UHF Antenna	74	1.5	-
	—	—	—
TOTAL	114	4.0	10

SLG-2

COMMUNICATION REQUIREMENTS

<u>Unit</u>	<u>Volume (cu in.)</u>	<u>Mass (lb)</u>	<u>Power (watt)</u>
Command Receiver	40	2.5	6
PCM/FM Transmitter	40	2.5	10
S-Band Transponder	60	4.5	10
UHF Antenna			
1. 2 Turnstile	62	1.0	-
2. Circulator	50	1.0	-
S-Band Antenna (2 required) (mount on same turnstile)	17	0.8	-
	---	---	---
TOTAL	269	12.3	26

Remarks:

1. Satellite not stabilized; therefore, two turnstile antennas required. Same turnstile arm mounting support used for both UHF and S-Band antennas.
2. Same antenna system used for Command Receiver and PCM/FM transmitter; circulator used for isolation.
3. S-Band transponder required to locate and track the satellite.

SLG-3

COMMUNICATION REQUIREMENTS

<u>Unit</u>	<u>Volume (cu in.)</u>	<u>Mass (lb)</u>	<u>Power (watt)</u>
Command Receiver	40	2.5	6
S-Band Transponder	60	4.5	10
Antennas			
1. Command Receiver	38	1.0	-
2. S-Band	17	0.8	-
	—	—	—
TOTAL	155	8.8	16

Remarks:

1. Satellite not stabilized with respect to Earth; therefore, two antennas required.
2. Command Receiver required to control the experiment and initiate the recovery sequence.
3. The S-Band transponder required to locate and track the satellite.



SLG-5

COMMUNICATION REQUIREMENTS

<u>Unit</u>	<u>Volume (cu in.)</u>	<u>Mass (lb)</u>	<u>Power (watt)</u>
Command Receiver	40	2.5	6
Digital UHF Transmitter	40	2.5	10
S-Band Beacon	60	4.5	10
UHF Antennas (turnstile)	62	1.0	-
S-Band Antenna (turnstile)	17	0.8	-
	—	—	—
TOTAL	269	12.3	26

Remarks:

1. Satellite not stabilized; all antennas mounted on beam turnstile type.

## M-1

## COMMUNICATION REQUIREMENTS

<u>Unit</u>	<u>Volume (cu in.)</u>	<u>Mass (lb)</u>	<u>Power (watt)</u>
Command Receiver	40	2.5	6
S-Band Transponder	60	4.5	10
S-Band Telemetry	93	7.0	15
Antennas (See 4, below)			
1. Command Receiver turnstile	50	1.0	-
2. S-Band turnstile	17	0.8	-
3. Antenna switch	17	0.8	-
	—	—	—
TOTAL	277	16.6	31

## Remarks:

1. TV data taken directly from camera on command and transmitted to Earth over S-Band telemetry transmitter.
2. Command data from ground station.
3. S-Band transponder required for satellite location, and range and range rate information.
4. No astronaut participation required; consequently, the satellite independent and unstabilized. In unstable satellites, omni-coverage antennas required to ensure reception of command data and transmission of collected experiment data.
5. Turnstile type antennas required for both S-Band telemetry and UHF Command Receiver. Antennas mounted on extended booms whereby one (each band) always in L.O.S. of the Earth. Two booms are normally required to provide adequate coverage.

## M-2

## COMMUNICATION REQUIREMENTS

<u>Unit</u>	<u>Volume (cu in.)</u>	<u>Mass (lb)</u>	<u>Power (watt)</u>
Command Receiver	40	2.5	6
S-Band Transponder	60	4.5	10
S-Band Telemetry	93	7.0	15
Antennas			
1. Command Receiver	38	0.8	-
*2. S-Band Transponder (Switch)	17	0.8	-
*3. S-Band Telemetry	62	1.5	-
		<hr/>	<hr/>
TOTAL	310	17.1	31

## Remarks:

1. TV data.
2. Command data from ground station.
3. Range and range rate information for location and tracking.
4. Timing and position data transmitted with TV on subcarrier.
5. Satellite space stabilized.

\*One antenna system for S-Band transponder and S-Band telemetry;  
a switch used to control output as directed from Command Receiver.

## COMMUNICATION REQUIREMENTS

<u>Unit</u>	<u>Volume (cu in.)</u>	<u>Mass (lb)</u>	<u>Power (watt)</u>
Command Receiver	40	2.5	6
S-Band Transponder	60	4.5	10
S-Band Telemetry	93	7.0	15
Antennas (See 4, below)			
1. Command Receiver turnstile	50	1.0	-
2. S-Band turnstile	17	0.8	-
3. Antenna switch	17	0.8	-
	—	—	—
TOTAL	277	16.6	31

## Remarks:

1. TV data taken directly from camera on command and transmitted to Earth over S-Band telemetry transmitter.
2. Command data from ground station.
3. S-Band transponder required for satellite location, and range and range rate information.
4. Satellite not stabilized; therefore, turnstile antennas required for S-Band telemetry and Command Receiver. Antennas mounted on extended booms whereby one antenna (each band type) always in L.O.S. of the Earth. Two booms normally required for adequate coverage.
5. One antenna system used for the S-Band transponder and S-Band telemetry; a switch used to control output as directed from the Command Receiver.

## M-4

## COMMUNICATION REQUIREMENTS

<u>Unit</u>	<u>Volume (cu in.)</u>	<u>Mass (lb)</u>	<u>Power (watt)</u>
Command Receiver	40	2.5	6
S-Band Transponder	60	4.5	10
S-Band Telemetry	93	7.0	15
Antennas (See 4, below)			
1. Command Receiver turnstile	50	1.0	-
2. S-Band turnstile	17	0.8	-
3. Antenna switch	17	0.3	-
	—	—	
TOTAL	277	16.6	31

## Remarks:

1. TV data taken directly from camera on command.
2. Command data from ground station.
3. Transponder required for satellite location, and range and range rate information.
4. Satellite not stabilized; therefore, turnstile antennas required for S-Band telemetry and Command Receiver. Antennas mounted on extended booms whereby one antenna (each band type) always in L.O.S. of the Earth. Two booms normally required for adequate coverage.
5. One antenna system used for the S-Band transponder and S-Band telemetry; a switch used to control output as directed from the Command Receiver.

## M-5

## COMMUNICATION REQUIREMENTS

<u>Unit</u>	<u>Volume (cu in.)</u>	<u>Mass (lb)</u>	<u>Power (watt)</u>
Command Receiver	40	2.5	6
PCM/FM Transmitter	40	2.5	10
S-Band Transponder	60	4.5	10
UHF Antenna			
1. 2 Turnstile (See 1, below)	62	1.0	-
2. Circulator	50	1.0	-
S-Band Antenna (2 required) (See 1, below)	17	0.8	-
	<hr/>	<hr/>	<hr/>
TOTAL	269	12.3	26

## Remarks:

1. Satellite not stabilized; therefore, two turnstile antennas required. Same boom arm mounting support used for both UHF and S-Band antennas.
2. Same antenna system used for Command Receiver and PCM/FM transmitter; circulator used for isolation.
3. S-Band transponder required for location and tracking of the satellite.
4. Command Receiver required to control experiment and turn UHF transmitter on-off.
5. Telemetry data taken from tape recorder.

OEA-1

COMMUNICATION REQUIREMENTS

<u>Unit</u>	<u>Volume (cu in.)</u>	<u>Mass (lb)</u>	<u>Power (watt)</u>
UHF Transmitter	40	2.5	10
Antenna (Stab.)	74	1.5	-
	—	—	—
TOTAL	114	4.0	10

OEA-2

COMMUNICATION REQUIREMENTS

<u>Unit</u>	<u>Volume (cu in.)</u>	<u>Mass (lb)</u>	<u>Power (watt)</u>
Command Receiver	40	2.5	6
PCM/FM UHF Transmitter	40	2.5	10
UHF Antenna System (Combination receiver and trans- mitter using two antennas and circulator)	52	2.0	-
	—	—	—
TOTAL	132	7.0	16

Remarks:

1. Satellite space stabilized.
2. Separate command and PCM/FM telemetry required.
3. Single antenna system of two (2) 9-inch verticals spaced for maximum coverage; circulator used for isolation between the transmitter and receiver.
4. Crew participation required for aiming of the electronic gun and for experiment equipment check-out.



OEA-3

COMMUNICATION REQUIREMENTS

<u>Unit</u>	<u>Volume (cu in.)</u>	<u>Mass (lb)</u>	<u>Power (watt)</u>
Command Receiver	40	2.5	6
PCM/FM UHF Transmitter	40	2.5	10
UHF Antenna System (Combination receiver and trans- mitter using two antennas and circulator)	52	2.0	-
	—	—	—
TOTAL	132	7.0	16

Remarks:

1. The satellite stabilized because of the experiment requirements; data to be stored on magnetic tape and transmitted to Earth on command.
2. The data transmission link will be accomplished by use of a PCM/FM UHF telemetry system.
3. A single antenna system used for Command Receiver and the PCM/FM transmitter; circulator used for isolation.

OEA-4

COMMUNICATION REQUIREMENTS

<u>Unit</u>	<u>Volume (cu in.)</u>	<u>Mass (lb)</u>	<u>Power (watt)</u>
Command Receiver	40	2.5	6
S-Band Transponder	60	4.5	10
<b>Antennas</b>			
1. Command Receiver	38	1.0	-
2. S-Band	17	0.8	-
	—	—	—
<b>TOTAL</b>	<b>155</b>	<b>8.8</b>	<b>16</b>

OEA-5

COMMUNICATION REQUIREMENTS

<u>Unit</u>	<u>Volume (cu in.)</u>	<u>Mass (lb)</u>	<u>Power (watt)</u>
Command Receiver	40	2.5	6
PCM/FM Transmitter	40	2.5	10
S-Band Transponder	60	4.5	10
UHF Antenna			
1. 2 Turnstile	62	1.0	-
2. Circulator	50	1.0	-
S-Band Antenna (2 required) (mount on same turnstile)	17	0.8	-
	—	—	—
TOTAL	269	12.3	26

Remarks:

1. Satellite not stabilized; therefore, two turnstile antennas required. Same turnstile arm mounting support used for both UHF and S-Band antennas.
2. Same antenna system used for Command Receiver and PCM/FM transmitter; circulator used for isolation.
3. S-Band transponder required for location and tracking of the satellite.
4. Command Receiver required to control experiment and turn UHF transmitter on-off.
5. Telemetry data taken from tape recorder.

## A P P E N D I X F

### E L E C T R I C P O W E R W O R K S H E E T S

The worksheets in this appendix contain the following data in tabular form: applicable electric peak power, duty cycle (ratio of "on" time to total mission time), and energy requirements for the experiments described in Appendix A. The mass, volume, and deployed area of the electric power systems are also indicated. Data on ancillary electric power systems for Experiments SDT-1, SDT-2, and SDT-5 are not included because the electric power requirements for these experiments are assumed to be satisfied by the definitions of the experiments. A detailed discussion of electric power systems is presented in subsection 4.5 of this report.

## ELECTRIC POWER

	Power (watt)	Duty Cycle*	On Time (hour)	Energy (watt-hour)
Mission Duration: 14 Days = 336 Hours				
Star tracker	5	0.5	168	840
Planet tracker	5	0.5	168	840
Tracker electronics	10	1.0	336	3360
Automatic sextant	5	0.25	84	420
Sextant electronics	10	0.25	84	840
Exp. control computer	25	1.0	336	8400
IMU	100	1.0	336	33600
IMU electronics	40	1.0	336	14440
Horizon scanner	10	1.0	336	3360
Digital computer	50	1.0	336	16800
Tape recorder	15	1.0	336	5040
Command receiver	6	1.0	336	2016
Transponder	10	1.0	336	3360
Transmitter	10	0.25	84	840
TOTAL	301			94156
		Mass (lb)	Volume (cu in.)	Area (sq in.)
Fuel cell module & controls		50	1990	
Radiator		7.2		1040
Coolant and piping		7.2		
H <sub>2</sub> tank		32	4849	
O <sub>2</sub> tank		24	3591	
H <sub>2</sub>		9.5		
O <sub>2</sub>		76		
Power conditioning		8	160	
Distribution		8		
TOTAL		222	10590	1040

\* Ratio of "on" time to total mission time.

SDT-4

ELECTRIC POWER

	Power (watt)	Duty Cycle	On Time (hour)	Energy (watt-hour)
Mission Duration: 4 Days = 96 Hours				
Sensors	6	1.0	96	576
Data automation	57	1.0	96	5472
Attitude control	50	1.0	96	4800
Command receiver	6	1.0	96	576
Transponder	10	1.0	96	960
Transmitter	<u>10</u>	0.083	8	<u>80</u>
TOTAL	139			12464

	Mass (lb)	Volume (cu in.)
Battery	200	3400
Power conditioning	5	100
Distribution	6	
TOTAL	<u>211</u>	<u>3500</u>

MS-1

ELECTRIC POWER

	Mission Duration:	30 Days	Power	Duty Cycle	On Time	Energy
	=	720 Hours	(watt)	(hour)	(hour)	(watt-hour)
Experiment sensors			130			300
Sun sensor			10	0.2	144	1440
Tape recorder			22	0.2	144	3168
Programmer			8	0.2	144	1152
Encoder			12	0.2	144	1728
Command receiver			6	0.2	144	864
Transponder			10	0.2	144	1440
Attitude control			<u>50</u>	1.0	720	<u>36000</u>
	TOTAL		248			46092

	Mass	Volume	Area
	(lb)	(cu in.)	(sq in.)
Fuel cell module & control	68	1990	
Radiator	7.2		1040
Coolant and piping	7.2		
H <sub>2</sub> tank	16	2483	
O <sub>2</sub> tank	12	1563	
H <sub>2</sub>	5.5		
O <sub>2</sub>	45		
Power conditioning	9	180	
Distribution	<u>9</u>		
	TOTAL	6216	1040

MS-2

ELECTRIC POWER

	Power (watt)	Duty Cycle	On Time (hour)	Energy (watt-hour)
Mission Duration: 27 Hours				
Sensors	200	0.111	3	600
Encoder	12	0.111	3	36
Tape recorder	20	0.111	3	60
Programmer	8	0.111	3	24
Command receiver	6	1.0	27	162
Transponder	10	1.0	27	270
Transmitter	<u>10</u>	0.111	3	<u>30</u>
TOTAL	266			1182

	Mass (lb)	Volume (cu in.)
Battery	25	425
Power conditioning	8	160
Distribution	8	
TOTAL	41	585



MS-3

ELECTRIC POWER

Mission Duration: 26 Hours	Power (watt)	Duty Cycle	On Time (hour)	Energy (watt-hour)
Sensor	100	1.0	26	2600
Encoder	12	1.0	26	312
Tape recorder	22	1.0	26	572
Programmer	8	1.0	26	208
Communications	<u>26</u>	1.0	26	<u>676</u>
TOTAL	168			4368

394

	Mass (lb)	Volume (cu in.)
Battery	70	1190
Power conditioning	6	120
Distribution	<u>6</u>	<u>        </u>
TOTAL	82	1310

MS-4

ELECTRIC POWER

Mission Duration:	15 Hours	Power (watt)	On Time (hour)	Energy (watt-hour)	Mass (lb)	Volume (cu in.)
Sensors		500	2	1000		
Data automation		40	2	80		
Command receiver		6	15	90		
Transponder		10	15	150		
Transmitter		<u>10</u>	2	<u>20</u>		
	TOTAL	566		1340		
Battery					46	782
Power conditioning					7	140
Distribution					<u>7</u>	
	TOTAL	60			60	922

MS-5

ELECTRIC POWER

	Mission Duration: 2.5 Hours	Power (watt)	On Time (hour)	Energy (watt-hour)
Sensors		40	0.25	10
Data automation		40	0.25	10
Command receiver		6	2.5	15
Transponder		10	2.5	25
Transmitter		<u>10</u>	0.25	<u>2.5</u>
	TOTAL	106		62.5

Battery	Mass (lb)	Volume (cu in.)
Power conditioning	40	680
Distribution	5	100
	<u>5</u>	<u>      </u>
	TOTAL	780

MI-1

ELECTRIC POWER

	Power (watt)	Duty Cycle (hour)	On Time (hour)	Energy (watt-hour)
Sensors	805	-	1.33	1070
Sequencer	50	-	1.33	66
Data automation	45	-	2.67	120
Attitude control	50	1.0	336	16800
Command receiver	6	1.0	336	2016
Transponder	10	1.0	336	3360
Transmitter	10	-	1.33	14
<b>TOTAL</b>	<b>976</b>			<b>23446</b>

Mission Duration: 14 Days  
= 336 Hours

	Mass (lb)	Volume (cu in.)
Battery	375	6370
Power conditioning	15	300
Distribution	15	
<b>TOTAL</b>	<b>405</b>	<b>6670</b>

MI-2

ELECTRIC POWER

Mission Duration: 14 Days  
= 336 Hours

	Power (watt)	On Time (hour)	Energy (watt-hour)
Sensor	700	10	7000
Data automation	316	18.3	5700
Communications	46	8.3	382
Attitude control	50	168	8400
Cryogenic cooler	200	2.5	500
TOTAL	<u>1312</u>		<u>21982</u>

398

Battery	Mass (lb)	Volume (cu. in.)
Power conditioning	348	4350
Distribution	15	300
	15	
TOTAL	<u>378</u>	<u>4650</u>

MI-3

ELECTRIC POWER

	Power (watt)	Duty Cycle	On Time (hour)	Energy (watt-hour)
Mission Duration: 14 Days = 336 Hours				
Sensors	1700	0.0416	14	23800
Programmer	16	0.0833	28	448
Video tape recorder	300	0.0833	28	8400
Attitude control	50	1.0	336	16800
Command receiver	6	1.0	336	2016
Transponder	10	1.0	336	3360
Transmitter	15	0.0416	14	210
<b>TOTAL</b>	<b>2097</b>			<b>55034</b>

	Mass (lb)	Volume (cu in.)	Area (sq in.)
Module & controls	187	7850	
Radiator	62.1		9000
Coolant and piping	62.1		
H <sub>2</sub> tank	16	2572	
O <sub>2</sub> tank	24	1900	
H <sub>2</sub>	7		
O <sub>2</sub>	56		
Power conditioning	30	600	
<b>TOTAL</b>	<b>445</b>	<b>12922</b>	<b>9000</b>

MI-4

ELECTRIC POWER

	Power (watt)	Duty Cycle	On Time (hour)	Energy (watt-hour)
Mission Duration: 7 Days = 168 Hours				
Sensor	375	0.0348	5.85	2190
Programmer	16	0.0348	5.85	94
Video tape recorder	300	0.0696	11.7	3510
Attitude control	50	1.0	168	8400
Command receiver	6	1.0	168	1008
Transponder	10	1.0	168	1680
Transmitter	30	0.0348	5.85	175
	<u>787</u>			<u>17057</u>
TOTAL	787			17057

	Mass (lb)	Volume (cu in.)
Battery	206	3300
Power conditioning	14	280
Distribution	14	
	<u>234</u>	<u>3580</u>
TOTAL	234	3580

MI-5

ELECTRIC POWER

	Power (watt)	On Time (hour)	Energy (watt-hour)
Mission Duration: 20 Days = 480 Hours			
Cameras	570	16	9100
Camera control	30	16	480
Programmer	16	32	512
Tape recorder	22	16	352
V/H Sensor	15	16	240
Encoder	12	16	192
Command receiver	6	480	2880
Transponder	<u>10</u>	480	<u>4800</u>
	681		18556
TOTAL			

	Mass (lb)	Volume (cu in.)
Battery	197	5050
Power conditioning	12	240
Distribution	<u>12</u>	<u>        </u>
TOTAL	321	5290



SLG-1

ELECTRIC POWER

Mission Duration: 2 Hours	Power (watt)	Duty Cycle	On Time (hour)	Energy (watt-hour)
Heater	50	1.0	2	100
Lights	500	-	0.167	84
Camera	1000	-	0.167	167
Sequence controller	10	1.0	2	20
Data automation	57	1.0	2	114
Communication	<u>10</u>	1.0	2	<u>20</u>
<b>TOTAL</b>	<b>1627</b>			<b>505</b>

	Mass (lb)	Volume (cu in.)
Battery	15	250
Power conditioning	4	60
Distribution	<u>8</u>	<u>      </u>
<b>TOTAL</b>	<b>27</b>	<b>310</b>

SLG-2

ELECTRIC POWER

Mission Duration:	24 Hours	Power (watt)	Duty Cycle	On Time (hour)	Energy (watt-hour)
Sensors		125	1.0	24	3000
Programmer		10	1.0	24	240
Data automation		57	1.0	24	1368
Communication		<u>26</u>	1.0	24	<u>624</u>
<b>TOTAL</b>		218			5232

	Mass (lb)	Volume (cu in.)
Battery	83.5	1420
Power conditioning	7	140
Distribution	<u>6</u>	—
<b>TOTAL</b>	96.5	1560

SLG-3

ELECTRIC POWER

Mission Duration: 15 Hours	Power (watt)	On Time (hour)	Energy (watt-hour)
Sensor	50	7.5	375
Programmer	10	20	200
Data automation	57	7.5	470
Attitude control	50	20	1000
Communications	<u>16</u>	24	<u>384</u>
TOTAL	183		2429

404

	Mass (lb)	Volume (cu in.)
Battery	50	850
Power conditioning	12	240
Distribution	<u>12</u>	<u>        </u>
TOTAL	74	1090

SLG-4

ELECTRIC POWER

Mission Duration: 2 Hours	Power (watt)	On Time (hour)	Energy (watt-hour)
Camera	75	1	75
Agitator	100	0.7	70
Lights	50	2	100
Positioner	100	0.1	10
Programmer	<u>10</u>	4	<u>40</u>
TOTAL	335		295

405

	Mass (lb)	Volume (cu in.)
Battery	14	250
Power conditioning	12	240
Distribution	<u>8</u>	—
TOTAL	34	490

SLG-5

ELECTRIC POWER

Mission Duration: 35 Hours	Power (watt)	On Time (hour)	Energy (watt-hour)
Combustion equipment	10	35	350
Data automation	57	40	2280
Communication	<u>26</u>	40	<u>1040</u>
TOTAL	93		3670

	Mass (lb)	Volume (cu in.)
Battery	60	1020
Power conditioning	6	120
Distribution	<u>6</u>	—
TOTAL	72	1140

M-1

ELECTRIC POWER

	Power (watt)	On Time (hour)	Energy (watt-hour)
Motor	25	24	600
Exposure plates	50	24	1200
Microscope	50	24	1200
TV camera	5	24	120
Command receiver	6	45	270
Transponder	10	45	450
Transmitter	<u>15</u>	24	<u>360</u>
TOTAL	161		4200

Mission Duration: 14 Days  
= 336 Hours

	Mass (lb)	Volume (cu in.)
Battery	80	1360
Power conditioning	7	140
Distribution	<u>7</u>	<u>      </u>
TOTAL	94	1500

ELECTRIC POWER

	Power (watt)	On Time (hour)	Energy (watt-hour)
Mission Duration: 3.5 Days = 84 Hours			
Microscope	50	2.4	120
Spectrometer	50	14	700
Gas chromatograph	100	3	300
Encoder	12	14	168
TV camera	5	2.4	12
Command receiver	6	10	60
Transponder	10	10	100
Transmitter	<u>15</u>	14	<u>210</u>
TOTAL	248		1670

	Mass (lb)	Volume (cu in.)
Battery	24	407
Power conditioning	7	140
Distribution	<u>7</u>	—
TOTAL	38	547

M-3

ELECTRIC POWER

	Power (watt)	Duty Cycle	On Time (hour)	Energy (watt-hour)
Sensors	155	-	6	930
Programmer	10	-	6	60
TV camera	5	-	6	30
Command receiver	6	1.0	240	1440
Transponder	10	1.0	240	2400
Transmitter	15	-	6	90
Heater	-	-	-	<u>250</u>
<b>TOTAL</b>	<b>201</b>			<b>5200</b>

Mission Duration: 10 Days  
= 240 Hours

	Mass (lb.)	Volume (cu in.)
Battery	84	1430
Power conditioning	8	160
Distribution	<u>8</u>	<u>          </u>
<b>TOTAL</b>	<b>100</b>	<b>1590</b>



M-4

ELECTRIC POWER

	Power (watt)	On Time (hour)	Energy (watt-hour)
Mission Duration: 30 Days = 720 Hours			
Sensors	75	2.5	188
TV camera	5	2.5	13
Command receiver	6	50	300
Transponder	10	50	500
Transmitter	15	2.5	38
Heater	-	-	<u>750</u>
TOTAL	111		1789

	Mass (lb)	Volume (cu in.)
Battery	43	727
Power conditioning	7	140
Distribution	<u>7</u>	-
TOTAL	57	867

M-5

ELECTRIC POWER

Mission Duration: 15 Days  
= 360 Hours

	Power (watt)	On Time (hour)	Energy (watt-hour)
Sensors	75	42	3150
Sequencer	10	42	420
Data automation	57	57	325
Command receiver	6	135	810
Transponder	10	135	1350
Transmitter	10	15	150
Heater	-	-	500
<b>TOTAL</b>	<b>168</b>		<b>6705</b>

	Mass (lb)	Volume (cu in.)
Battery	108	1840
Power conditioning	8	160
Distribution	8	-
<b>TOTAL</b>	<b>124</b>	<b>2000</b>

OEA-1

ELECTRIC POWER

	Mission Duration: 3.5 Days = 84 Hours	Power (watt)	On Time (hour)	Energy (watt-hour)
Sensors		5.4	84	454
Computer and display		53	84	4452
Tape recorder		45	84	3780
Encoder		12	84	1008
Communication		<u>10</u>	84	<u>840</u>
<b>TOTAL</b>		125.4		10534

	Mass (lb)	Volume (cu in.)
Battery	169	2865
Power conditioning	6	120
Distribution	<u>8</u>	<u>          </u>
<b>TOTAL</b>	183	2985

OEA-2

ELECTRIC POWER

	Mission Duration: 3.1 Days = 75 Hours	Power (watt)	On Time (hour)	Energy (watt-hour)
Sensors		200	14	2800
Encoder		12	14	168
Tape recorder		2	14	28
Command receiver		6	14	84
Transmitter		<u>10</u>	14	<u>140</u>
	TOTAL	230		3220

	Mass (lb)	Volume (cu in.)
Battery	52	880
Power conditioning	6	120
Distribution	<u>6</u>	<u>        </u>
TOTAL	64	1000

OEA-3

ELECTRIC POWER

	Power (watt)	Duty Cycle	On Time (hour)	Energy (watt-hour)
Mission Duration: 5 Days = 120 Hours				
Sensors	50	1.0	120	6000
Encoder	12	0.1	12	144
Tape recorder	45	0.1	12	540
Command receiver	6	1.0	120	720
Transmitter	<u>10</u>	0.05	6	<u>60</u>
TOTAL	123			4764

	Mass (lb)	Volume (cu in.)
Battery	120	2040
Power conditioning	5	100
Distribution	<u>5</u>	<u>        </u>
TOTAL	130	2140

OEA-4

ELECTRIC POWER

	Mission Duration: 5 Days = 120 Hours	Power (watt)	Duty Cycle	On Time (hour)	Energy (watt-hour)
Programmer		16	0.1	12	192
Attitude control		50	1.0	120	6000
Command receiver		6	1.0	120	720
Transponder		<u>10</u>	1.0	120	<u>1200</u>
TOTAL		82			8112

	Mass (lb)	Volume (cu in.)
Battery	127	2150
Power conditioning	5	100
Distribution	<u>5</u>	<u>    </u>
TOTAL	137	2250

OEA-5

ELECTRIC POWER

Mission Duration: 14 Days  
= 336 Hours

	Power (watt)	Duty Cycle	On Time (hour)	Energy (watt-hour)
Sensor	10	-	3.5	35
Encoder	12	-	7	84
Tape recorder	45	-	7	315
Programmer	10	-	7	70
Command receiver	6	1.0	336	2016
Transponder	10	1.0	336	3360
Transmitter	10	-	7	70
Attitude Control	50	1.0	336	16800
Heater	---			<u>750</u>
TOTAL	153			23500

	Mass (lb)	Volume (cu in.)
Battery	296	5030
Power conditioning	9	180
Distribution	<u>9</u>	---
TOTAL	314	5210

## A P P E N D I X G

### T H E R M A L C O N T R O L W O R K S H E E T S

Data on the mass, volume, and power required for thermal control in the experiments described in Appendix A are presented in tabular form on the following worksheets. The system concept selected for each experiment is also indicated. A detailed discussion of thermal control systems is presented in subsection 4.6 of this report.



SATURN IB SECONDARY PAYLOADS STUDY  
ENVIRONMENTAL CONTROL SYSTEM DESCRIPTION  
FOR EXPERIMENT SDT-1

EXPERIMENT TITLE: RADIOISOTOPE THERMOELECTRIC POWER SYSTEM  
INTEGRATION

1. System Concept

Prelaunch cooling provided by cooling water, 1 gpm. During launch, heat dissipated by water boiler. Insulation used to prevent excessive heating of other components by the RTG and to isolate life support components. Thermal control surface coatings also used in orbit.

2. System Weight

Water boiler/heat-exchanger (including 2.4 lb water)	14.4 lb
Insulation	10.0 lb

3. System Volume

Water boiler/heat exchanger - 6" x 8" x 12"

Insulation - 1" over RTG  
Rest distributed over life support  
components, density = 4 lb/ft<sup>3</sup>.

4. Power Requirement

None

5. Remarks

SATURN IB SECONDARY PAYLOADS STUDY  
ENVIRONMENTAL CONTROL SYSTEM DESCRIPTION  
FOR EXPERIMENT SDT-2

EXPERIMENT TITLE: PERFORMANCE ASSESSMENT OF THIN-FILM SOLAR  
CELL ARRAYS

1. System Concept

Temperature control maintained by suitable use of insulation and proper selection of thermal control coatings. A small amount of high-temperature insulation required to insulate the catalyst bed of the propulsion system.

2. System Weight

Insulation - 3 lbm

High-temperature insulation - negligible

Thermal control coating negligible

3. System Volume

Insulation - 1/4" on exterior of equipment package, propulsion package, and base compartments of cell arrays.

4. Power Requirement

No additional power requirement.

5. Remarks

Thermal control coating may be required on portion of inflatable structure not covered with thin-film cells.

SATURN IB SECONDARY PAYLOADS STUDY  
ENVIRONMENTAL CONTROL SYSTEM DESCRIPTION  
FOR EXPERIMENT SDT-3

EXPERIMENT TITLE: PERFORMANCE ASSESSMENT OF SPACECRAFT NAVIGATION,  
GUIDANCE AND CONTROL HARDWARE AND TECHNIQUES

1. System Concept

Adequate thermal control achieved by use of a suitable  
thermal control coating and insulation.

2. System Weight

Insulation - 5 lbm

3. System Volume

Small thickness (negligible on drawing) of insulation  
on package exterior.

4. Power Requirement

None

5. Remarks

SATURN IB SECONDARY PAYLOADS STUDY  
ENVIRONMENTAL CONTROL SYSTEM DESCRIPTION  
FOR EXPERIMENT SDT-4

EXPERIMENT TITLE: CRYOGENIC PROPELLANT STORAGE SYSTEM  
PERFORMANCE

1. System Concept

Insulation on the LH<sub>2</sub> tank, a basic part of the experiment. Use of suitable thermal control coating and insulation sufficient for thermal control of the equipment package during launch and orbit.

2. System Weight

Insulation - 10 lbm

3. System Volume

1/2" insulation on LH<sub>2</sub> tank

1/4" insulation over equipment package

4. Power Requirement

None

5. Remarks

A continuous supply of LH<sub>2</sub> required during the prelaunch phase as make-up for hydrogen boil-off.

SATURN IB SECONDARY PAYLOADS STUDY  
ENVIRONMENTAL CONTROL SYSTEM DESCRIPTION  
FOR EXPERIMENT SDT-5

EXPERIMENT TITLE: LAUNCH OF UNMANNED SATELLITES AND PROBES

1. System Concept

Insulation and a suitable thermal control coating  
sufficient for thermal control.

2. System Weight

Insulation - 1.5 lbm

3. System Volume

1/4" insulation over tank surface

4. Power Requirement

None

5. Remarks

SATURN IB SECONDARY PAYLOADS STUDY  
ENVIRONMENTAL CONTROL SYSTEM DESCRIPTION  
FOR EXPERIMENT MS-1

EXPERIMENT TITLE: DEGRADATION OF ORGANIC MATERIALS IN SPACE  
ENVIRONMENT

1. System Concept

Temperature control achieved by use of a suitable  
thermal control coating and insulation.

2. System Weight

Insulation - 2 lbm

3. System Volume

1/4" insulation over cylindrical surface

4. Power Requirement

None

5. Remarks

SATURN IB SECONDARY PAYLOADS STUDY  
ENVIRONMENTAL CONTROL SYSTEM DESCRIPTION  
FOR EXPERIMENT MS-2

EXPERIMENT TITLE: BEHAVIOR OF LIQUID FILMS IN SPACE  
ENVIRONMENT

1. System Concept

Insulation and proper thermal control coatings sufficient  
for thermal control.

2. System Weight

Insulation - 1 lbm

3. System Volume

Negligible

4. Power Requirement

None

5. Remarks

SATURN IB SECONDARY PAYLOADS STUDY  
ENVIRONMENTAL CONTROL SYSTEM DESCRIPTION  
FOR EXPERIMENT MS-3

EXPERIMENT TITLE: VAPORIZATION RATE OF MOLTEN METALS

1. System Concept

Insulation and a suitable coating sufficient for thermal control.

2. System Weight

Insulation - 1 lbm

3. System Volume

Negligible

4. Power Requirement

None

5. Remarks



SATURN IB SECONDARY PAYLOADS STUDY  
ENVIRONMENTAL CONTROL SYSTEM DESCRIPTION  
FOR EXPERIMENT MS-4

EXPERIMENT TITLE: COLD WELDING OF METALS IN SPACE ENVIRONMENT

1. System Concept

Proper thermal control coating with insulation  
sufficient for thermal control.

2. System Weight

Insulation - 3 lbm

3. System Volume

Negligible

4. Power Requirement

None

5. Remarks

SATURN IB SECONDARY PAYLOADS STUDY  
ENVIRONMENTAL CONTROL SYSTEM DESCRIPTION  
FOR EXPERIMENT MS-5

EXPERIMENT TITLE: SPRAY COATING AND SURFACE CONTAMINATION

1. System Concept

Insulation with proper thermal control coating sufficient.

2. System Weight

Insulation - 2 lbm

3. System Volume

Negligible

4. Power Requirement

None

5. Remarks

SATURN IB SECONDARY PAYLOADS STUDY  
ENVIRONMENTAL CONTROL SYSTEM DESCRIPTION  
FOR EXPERIMENT MI-1

EXPERIMENT TITLES: MULTI-SPECTRAL SURVEILLANCE OF EARTH

1. System Concept

Operating temperature maintained by use of programmer heat dissipation with superinsulation around the experiment package and a thermal control coating. Separate heater and thermostat required for the spectroradiometers to allow close temperature control.

2. System Weight

Superinsulation - 7.5 lbm  
Heater - negligible

3. System Volume

Superinsulation - 1.9 ft<sup>3</sup>

4. Power Requirement

4 watts required for heater for spectroradiometers

5. Remarks

Thermal control coating will be selected to yield a mean sink temperature over the orbit in the range 0-70°F.

SATURN IB SECONDARY PAYLOADS STUDY  
ENVIRONMENTAL CONTROL SYSTEM DESCRIPTION  
FOR EXPERIMENT MI-2

EXPERIMENT TITLE: INFRARED LINE SCAN SURVEILLANCE OF EARTH

1. System Concept

20°K, required for the IR detector-scanner, achieved by a cryogenic cooler similar to that used on the F-111. Estimated that adequate temperature control of the remainder of the package achieved by the appropriate use of insulation and thermal control coatings.

2. System Weight

IR cooling unit - 22 lb

Insulation - 13.5 lb

3. System Volume

IR unit - 12" x 12" x 4"

Insulation - 1/4" assumed on outer surface of package.

4. Power Requirement

IR unit - 200 watts: assumed in operation during time line scanner used plus allowance of 10 minutes cool-down for each scan.

5. Remarks

SATURN IB SECONDARY PAYLOADS STUDY  
ENVIRONMENTAL CONTROL SYSTEM DESCRIPTION  
FOR EXPERIMENT MI-3

EXPERIMENT TITLE: RADAR SURVEILLANCE OF EARTH

1. System Concept

Louvers required to maintain thermal control during the peak heat dissipation period. Equipment mounted on the louvered surfaces. Insulation required to isolate the radiator and to insulate the electronic components.

2. System Weight

Louvers - 16 lbm

Insulation - 20 lbm

3. System Volume

4. Power Requirement

No additional power requirement

5. Remarks

SATURN IB SECONDARY PAYLOADS STUDY  
ENVIRONMENTAL CONTROL SYSTEM DESCRIPTION  
FOR EXPERIMENT MI-4

EXPERIMENT TITLE: ELECTRONIC IMAGE MOTION STABILIZATION SYSTEM  
FOR EARTH SURVEILLANCE AND SATELLITE TRACKING

1. System Concept

Telescope thermally isolated to reduce gradients. Temperature level dictated by compartment. Exterior surface of package and exposed area of mirror cavity generally insulated. Thermal control coatings used on package and equipment surfaces.

2. System Weight

Insulation - 18.5 lb

3. System Volume

Insulation - 1/4" over exterior surface

4. Power Requirement

None

5. Remarks

SATURN IB SECONDARY PAYLOADS STUDY  
ENVIRONMENTAL CONTROL SYSTEM DESCRIPTION  
FOR EXPERIMENT MI-5

EXPERIMENT TITLE: SYNOPTIC EARTH CARTOGRAPHY

1. System Concept

A suitable thermal control coating and insulation sufficient for thermal control.

2. System Weight

Insulation - 20 lbm

3. System Volume

1/4" insulation around electronic equipment sections of package.

4. Power Requirement

None

5. Remarks

SATURN IB SECONDARY PAYLOADS STUDY  
ENVIRONMENTAL CONTROL SYSTEM DESCRIPTION  
FOR EXPERIMENT SLG-1

EXPERIMENT TITLE: BOILING IN ZERO-G ENVIRONMENT

1. System Concept

Maintenance of an adequate operating temperature allowed by means of heat dissipation by electronic equipment together with insulated equipment and a thermal control coating.

2. System Weight

Insulation - 4.8 lbm

3. System Volume

Insulation - 1.6 ft<sup>3</sup>

4. Power Requirement

No additional power requirement

5. Remarks



SATURN IB SECONDARY PAYLOADS STUDY  
ENVIRONMENTAL CONTROL SYSTEM DESCRIPTION  
FOR EXPERIMENT SLG-2

EXPERIMENT TITLE: NUCLEATE CONDENSATION IN ZERO-GRAVITY

1. System Concept

Insulation and thermal control coatings sufficient to maintain temperature control.

2. System Weight

Insulation - 3 lbm

3. System Volume

1/4" over package exterior.

4. Power Requirement

No additional power requirement.

5. Remarks

SATURN IB SECONDARY PAYLOADS STUDY  
ENVIRONMENTAL CONTROL SYSTEM DESCRIPTION  
FOR EXPERIMENT SLG-3

EXPERIMENT TITLE: FORMATION OF SINGLE CRYSTALS

1. System Concept

Adequate temperature control of package provided by means of thermal control coating and insulation. High-temperature insulation required to insulate the samples.

2. System Weight

High temperature insulation - 6 lbm

Super insulation - 10 lbm

Thermal control coating - negligible

3. System Volume

Insulation - 1/4" over package exterior

4. Power Requirement

No additional power requirements

5. Remarks

SATURN IB SECONDARY PAYLOADS STUDY  
ENVIRONMENTAL CONTROL SYSTEM DESCRIPTION  
FOR EXPERIMENT SLG-4

EXPERIMENT TITLE: SEGREGATION OF IMMISCIBLE LIQUIDS UNDER  
ZERO-G CONDITIONS

1. System Concept

Adequate operating temperature in conjunction with insulation and thermal control coatings maintained by means of equipment heat dissipation. Separate heater required for data capsule.

2. System Weight

Insulation - 7.6 lbm

Heater - 1.2 lbm

Thermal control coatings - negligible

3. System Volume

Insulation - 2.5 ft<sup>3</sup>

4. Power Requirement

16 watts required for data capsule heater.

5. Remarks

SATURN IB SECONDARY PAYLOADS STUDY  
ENVIRONMENTAL CONTROL SYSTEM DESCRIPTION  
FOR EXPERIMENT SLG-5

EXPERIMENT TITLE: ZERO-G COMBUSTION

1. System Concept

Adequate temperature control achieved by use of insulation and proper thermal control coatings. High-temperature insulation required on the combustion chamber and relief chamber.

2. System Weight

Insulation - 2.5 lbm

3. System Volume

Insulation - 1" high-temperature insulation on combustion chamber and relief chamber - 0.2 ft<sup>3</sup>

- 1/4" on exterior surface of package - 0.4 ft<sup>3</sup>

4. Power Requirement

No additional power requirement

5. Remarks

SATURN IB SECONDARY PAYLOADS STUDY  
ENVIRONMENTAL CONTROL SYSTEM DESCRIPTION  
FOR EXPERIMENT M-1

EXPERIMENT TITLE: SOFT CAPTURE, ENUMERATION AND IDENTIFICATION  
OF SPACE-BORNE MICROORGANISMS

1. System Concept

A louvered surface required for the equipment package because of the wide variation in heat dissipation over the mission. Insulation and a heater and thermostat required for incubation chamber to maintain the required temperature during the two-day incubation period. Suitable thermal control coatings will also be required.

2. System Weight

Louvers - 14 lbm

Insulation - 3 lbm

Heater - 1 lbm

3. System Volume

1/4" insulation over exterior of incubation chamber.

Louvers on 4 surfaces of equipment package.

4. Power Requirement

0.35 kw-hr required for heater

5. Remarks

SATURN IB SECONDARY PAYLOADS STUDY  
ENVIRONMENTAL CONTROL SYSTEM DESCRIPTION  
FOR EXPERIMENT M-2

EXPERIMENT TITLE: EFFECTS OF SPACE FLIGHTS ON MORPHOLOGY, GROWTH,  
AND LIQUID/GAS SEPARATION IN MICROORGANISMS

1. System Concept

Adequate temperature level maintained by means of a combination of thermal control coating and insulation with heater and thermostat. Components enclosed in a sealed package to retain pressure.

2. System Weight

Insulation - 1 lbm

Heater - negligible

3. System Volume

Insulation - 0.3 ft<sup>3</sup>

4. Power Requirement

5 watts required for heater.

5. Remarks

SATURN IB SECONDARY PAYLOADS STUDY  
ENVIRONMENTAL CONTROL SYSTEM DESCRIPTION  
FOR EXPERIMENT M-3

EXPERIMENT TITLE: INHERENT MUTATION RATES IN MICROORGANISMS AND  
EFFECTS OF EXTENDED SPACE FLIGHT IN THE  
EXPRESSION OF THE MUTATION

1. System Concept

Heater and thermostat required to maintain test cell and microscope temperature in addition to insulation and thermal control coating. Humidity maintained by means of saturated wick within test cell.

2. System Weight

Insulation - 5 lbm

Heater - 0.5 lbm

3. System Volume

Insulation - 1/2" over package exterior

- 1/4" over microscope and test cell

Heater - negligible

4. Power Requirement

0.25 kw-hr required for heater.

5. Remarks

SATURN IB SECONDARY PAYLOADS STUDY  
ENVIRONMENTAL CONTROL SYSTEM DESCRIPTION  
FOR EXPERIMENT M-4

EXPERIMENT TITLE: DETERMINATION OF THE MIGRATION OF MICRO-ORGANISMS IN A SPACECRAFT ENVIRONMENT

1. System Concept

Heater and thermostat required to maintain operating temperature in addition to insulation and thermal control coating. Saturated wick sealed into working chamber to maintain humidity.

2. System Weight

Insulation - 6 lbm

Heater - 1 lbm

3. System Volume

Insulation - 1/2" over package exterior

Heater - negligible

4. Power Requirement

0.75 kw-hr required for heater.

5. Remarks



SATURN IB SECONDARY PAYLOADS STUDY  
ENVIRONMENTAL CONTROL SYSTEM DESCRIPTION  
FOR EXPERIMENT M-5

EXPERIMENT TITLE: PRODUCTION OF NUTRIENTS BY CERTAIN MICRO-ORGANISMS WHILE IN SPACE FLIGHT

1. System Concept

Heater and thermostat will be required to maintain test chamber temperature. Insulation and thermal control coating required for the experiment package. Saturated work sealed into chamber to maintain humidity.

2. System Weight

Insulation - 3 lbm

Heater - 0.5 lbm

3. System Volume

Insulation - 1/4" over package exterior

Heater - negligible

4. Power Requirement

0.5 kw-hr required for test chamber heater

5. Remarks

SATURN IB SECONDARY PAYLOADS STUDY  
ENVIRONMENTAL CONTROL SYSTEM DESCRIPTION  
FOR EXPERIMENT OEA-1

EXPERIMENT TITLE: RADIATION ENVIRONMENT MONITORING

1. System Concept

Adequate thermal control provided by means of the continuous heat dissipation within the package coupled with insulation and a suitable thermal control coating.

2. System Weight

Insulation - 0.9 lbm

3. System Volume

Insulation - 0.22 ft<sup>3</sup>

4. Power Requirement

None

5. Remarks

Small portions of the package surface may have to be left uncovered to allow detection (alpha particle spectrometer, for example).

SATURN IB SECONDARY PAYLOADS STUDY  
ENVIRONMENTAL CONTROL SYSTEM DESCRIPTION  
FOR EXPERIMENT OEA-2

EXPERIMENT TITLE: STUDY OF MAGNETIC FIELD LINES

1. System Concept

Adequate thermal control attained by use of insulation and proper selection of thermal control coatings.

2. System Weight

Insulation - 5 lbm

3. System Volume

Insulation - 0.7 ft<sup>3</sup>

- 1/4" over exterior of package

4. Power Requirement

No additional power requirement

5. Remarks

SATURN IB SECONDARY PAYLOADS STUDY  
ENVIRONMENTAL CONTROL SYSTEM DESCRIPTION  
FOR EXPERIMENT OEA-3

EXPERIMENT TITLE: TEST OF PROTOTYPE STAR TRACKER

1. System Concept

Insulation and a suitable thermal control coating sufficient for thermal control.

2. System Weight

Insulation - 4 lbm

3. System Volume

1/8" insulation over package exterior

4. Power Requirement

None

5. Remarks

SATURN IB SECONDARY PAYLOADS STUDY  
ENVIRONMENTAL CONTROL SYSTEM DESCRIPTION  
FOR EXPERIMENT OEA-4

EXPERIMENT TITLE: COSMIC RAY EMULSION EXPERIMENT

1. System Concept

Heater and thermostat required to maintain the desired temperature of the emulsion pack. Insulation and a suitable thermal control coating required for equipment package.

2. System Weight

Insulation - 3.5 lbm

3. System Volume

Negligible thickness over package exterior ( $< 1/4''$ ).

4. Power Requirement

0.60 kw-hr required for emulsion pack heater.

5. Remarks

SATURN IB SECONDARY PAYLOADS STUDY  
ENVIRONMENTAL CONTROL SYSTEM DESCRIPTION  
FOR EXPERIMENT DEA-5

EXPERIMENT TITLE: EMISSION LINE RADIOMETRY

1. System Concept

A thermal control coating and insulation sufficient for thermal control of the electronics package. A heater and thermostat, in addition to insulation and a thermal control coating, required for interferometer telescope. A cryogenic cooler required for the IR detector.

2. System Weight

Insulation - 4 lbm

Heater - 1.5 lbm

IR cooling unit - 22 lbm

3. System Volume

Insulation - 1/4" over package exterior

IR unit - 12" x 12" x 4"

4. Power Requirement

0.7 kw-hr required for interferometer telescope heater.

IR unit - 200 watts required for 40-min periods

Total: 1 kw-hr

5. Remarks

# L I S T   O F   F I G U R E S

<u>Number</u>		<u>Page</u>
1-1	Saturn Experimental Payload Technical Evaluation and Rating	2
1-2	Basic Program Plan	4
2-1	Approach to Definition of Experiments	11
2-2	Approach to Limited Synthesis of Experiments	13
4-1	Attitude Control	24
4-2	Data Automation	25
4-3	Communications	28
4-4	Optimum Power Sources	29
4-5	Power System Configurations	30
4-6	Typical Power System Selection	32
4-7	Approach to Thermal Control System Design	33
5-1	Experiment Environmental Requirements	36
5-2	Experiment Vibration Environment	39
5-3	Experiment Electromagnetic Environment	41
6-1	Experiment M-1 Conceptual Design Drawing	44
6-2	Deployment Mode Definition	46
6-3	Experiment SDT-1 Configuration	50
6-4	Experiment SDT-2 Configuration	50
6-5	Experiment SDT-3 Configuration	51
6-6	Experiment SDT-4 Configuration	51
6-7	Experiment SDT-5 Configuration	52
6-8	Experiment MS-1 Configuration	52
6-9	Experiment MS-2 Configuration	53
6-10	Experiment MS-3 Configuration	53
6-11	Experiment MS-4 Configuration	54
6-12	Experiment MS-5 Configuration	54
6-13	Experiment MI-1 Configuration	55
6-14	Experiment MI-2 Configuration	55
6-15	Experiment MI-3 Configuration	56
6-16	Experiment MI-4 Configuration	56
6-17	Experiment MI-5 Configuration	57
6-18	Experiment SLG-1 Configuration	58
6-19	Experiment SLG-2 Configuration	58
6-20	Experiment SLG-3 Configuration	59
6-21	Experiment SLG-4 Configuration	59
6-22	Experiment SLG-5 Configuration	60
6-23	Experiment M-1 Configuration	60
6-24	Experiment M-2 Configuration	61

LIST OF FIGURES (Cont'd)

<u>Number</u>		<u>Page</u>
6-25	Experiment M-3 Configuration	61
6-26	Experiment M-4 Configuration	62
6-27	Experiment M-5 Configuration	62
6-28	Experiment OEA-1 Configuration	63
6-29	Experiment OEA-2 Configuration	63
6-30	Experiment OEA-3 Configuration	64
6-31	Experiment OEA-4 Configuration	64
6-32	Experiment OEA-5 Configuration	65
7-1	General Reliability Model Equation for Saturn In-Flight Experimental Payload Study	69
7-2	Reliability for Various In-Flight Durations	71
7-3	Cumulative Distribution of Development Span Times	73
8-1	Computer Program DESIGN Construction and Operation	80
8-2	Attitude Control Synthesis	81
8-3	Attitude Control Synthesis	81
8-4	Data Automation Synthesis - Component Selection	82
8-5	Data Automation Synthesis - Flow Chart	82
8-6	Communications System Synthesis - Component Selection	83
8-7	Communications System Synthesis - Flow Chart	84
8-8	Power System Synthesis	85
8-9	Power System Synthesis - Automatic System Selection	85
8-10	Electric Power System Relationships	86
8-11	Electric Power System Relationships	87
8-12	Electric Power System Relationships	87
8-13	Electric Power System Relationships	88
8-14	Electric Power System Relationships	88
8-15	Thermal Control System - Active Systems	90
8-16	Thermal Control System	91
8-17	DESIGN - Problem Input Data Printout	93
8-18	DESIGN - Output Data Printout	94



LIST OF FIGURES (Cont'd)

<u>Number</u>		<u>Page</u>
A.1-1	SDT-1 Conceptual Design Drawing	105
A.1-2	SDT-2 Thin-Film Cadmium - Sulphide Photo-voltaic In-Flight Experiment Package	110
A.1-3	SDT-2 Conceptual Design Drawing	111
A.1-4	SDT-3 Conceptual Design Drawing	120
A.1-5	SDT-4 Conceptual Design Drawing	125
A.1-6	SDT-5 Conceptual Design Drawing	135
A.2-1	MS-1 Timing System	143
A.2-2	MS-1 Sensor System: Temperature Recording	144
A.2-3	MS-1 Experiment Package	145
A.2-4	MS-1 Conceptual Design Drawing	146
A.2-5	MS-2 Wiring Diagram and Apparatus	152
A.2-6	MS-2 Conceptual Design Drawing	153
A.2-7	MS-3 Switch Unit and Wiring	160
A.2-8	MS-3 Conceptual Design Drawing	161
A.2-9	MS-4 Conceptual Design Drawing	170
A.2-10	MS-5 Conceptual Design Drawing	177
A.3-1	MI-1 Conceptual Design Drawing	194
A.3-2	MI-2 Conceptual Design Drawing	204
A.3-3	MI-3 Conceptual Design Drawing	212
A.3-4	MI-4 Conceptual Design Drawing	223
A.3-5	MI-5 Conceptual Design Drawing	233
A.4-1	SLG-1 Conceptual Design Drawing	238
A.4-2	SLG-2 Conceptual Design Drawing	243
A.4-3	SLG-3 Conceptual Design Drawing	248
A.4-4	SLG-4 Conceptual Design Drawing	253
A.4-5	SLG-5 Conceptual Design Drawing	258
A.5-1	M-1 Conceptual Design Drawing	264
A.5-2	M-2 Conceptual Design Drawing	270
A.5-3	M-3 Conceptual Design Drawing	275
A.5-4	M-4 Conceptual Design Drawing	280
A.5-5	M-5 Conceptual Design Drawing	285
A.6-1	OEA-1 Conceptual Design Drawing	293
A.6-2	OEA-2 Conceptual Design Drawing	299
A.6-3	OEA-3 Conceptual Design Drawing	304
A.6-4	OEA-4 Conceptual Design Drawing	309
A.6-5	OEA-5 Conceptual Design Drawing	316

# L I S T   O F   T A B L E S

<u>Number</u>		<u>Page</u>
3-1	Relationship of the Thirty Experiments Selected by General Dynamics for the Study to the NASA Major Scientific/ Technical Areas of Interest	20
3-2	Summary of Sensor Requirements	22
4-1	Experiment MI-3 Load Data	31
4-2	Ancillary Systems Mass Summary	34
5-1	Launch Vehicle Thermal Environment	37
5-2	Experiment Thermal Environment	38
5-3	Experiment Electromagnetic Environment	41
6-1	Mass Summary - Experiment M-1	45
6-2	Experiment Deployment Modes	47
6-3	Experiment Mass Summary	47
6-4	Experiment Volume Summary	49
7-1	Predicted Mean-Time-Between Failure of Experiment Equipment	68
7-2	Experiment Predicted Reliability	70
7-3	Development Schedule Analysis	72
7-4	Cost Analysis	74
A.1-1	SDT-1 Sensor Characteristics	103
A.1-2	SDT-3 Significant Physical Characteristics	119
A.2-1	MS-1 Measuring Amount	142
A.2-2	MS-1 Power Requirements	142
A.2-3	MS-3 Duration of Test Periods	159
A.6-1	OEA-1 Equipment List	292