

HIGH TEMPERATURE PROTECTIVE
COATINGS FOR REFRACTORY METALS

by

J. M. Criscione, J. Rexer, and R. G. Fenish

YEARLY SUMMARY REPORT
Prepared under Contract No. NASw-1030

UNION CARBIDE CORPORATION
CARBON PRODUCTS DIVISION
PARMA, OHIO

for

NATIONAL AERONAUTICS AND SPACE ADMINISTRATION

TABLE OF CONTENTS

<u>Section</u>	<u>Page</u>
I. INTRODUCTION	1
II. SUMMARY	1
III. RESEARCH PROGRAM	2
A. Sample Preparation	3
B. Chemical Compatibility	3
C. Mechanical Compatibility	4
D. Oxidation Studies	4
IV. EXPERIMENTAL	4
A. Materials	4
B. Sample Preparation	5
1. Fused Salt Electrodeposition of Iridium	5
2. Roll Bonding	6
3. Pressure Bonding	7
4. Electrodeposition of Refractory Metals	8
C. Sample Evaluation Techniques	8
1. Diffusion Studies	8
2. Mechanical Compatibility	10
3. Oxidation Tests	11
a. Oxygen-Methane Torch Tests	11
b. Air Furnace Tests	12
c. Coating Recession Rate Determinations	13
4. Visual Examination	15
V. RESULTS AND DISCUSSION	15
A. Coating Methods	15
1. Pressure and Roll Bonding	15
2. Fused Salt Electrodeposition of Iridium	16
a. Substrate Preparation Prior to Electrodeposition	16
b. Cell Chemistry	17
c. Voltage-Current Characteristics of the Fused Salt Cell	21
B. Diffusion Studies	23
C. Mechanical Compatibility	29
D. Oxidation Tests	30
1. Air Furnace Oxidation of Pressure Bonded Samples	31
a. Results of Duration-to-Failure Tests	31
b. Results of 15-Hour Tests	32

TABLE OF CONTENTS (Con't)

<u>Section</u>	<u>Page</u>
(1) Iridium-Tantalum System	32
(2) Iridium-Tungsten System	32
(3) Iridium-Niobium System	33
2. Air Furnace Oxidation of Electroplated Samples .	33
3. Summary of Air Furnace Oxidation Test Results .	34
4. Oxygen-Methane Torch Tests	35
E. Mechanical Behavior of Iridium	36
VI. FUTURE PLANS	39

HIGH TEMPERATURE PROTECTIVE COATINGS FOR REFRACTORY METALS

by

J. M. Criscione, J. Rexer, and R. G. Fenish

I. INTRODUCTION

Under Contract NASw-1030, a preliminary investigation was conducted on the use of iridium as a high temperature oxidation protective coating for tantalum, niobium, molybdenum, and tungsten. The results of the one year program are presented in this report.

II. SUMMARY

Iridium-coated specimens of all of the substrate metals, prepared by pressure bonding or electrodeposition techniques, were subjected to oxidation tests in slow moving air and in an oxygen-methane flame. The time-to-failure (36 hours to 117 hours for 0.005-inch thick pressure bonded coatings) experienced with iridium continues to point out its high promise as an oxidation protective coating for refractory metals. Premature failure of many of the electroplated samples was due to poor adherence of the coating. The overall oxidation study indicated that for some of the substrate metals the time-to-failure for an iridium coating can be increased by placing a diffusion barrier between the substrate metal and the iridium coating.

The rate of interdiffusion of iridium and tantalum was determined at various temperatures in the range 1200° to 1655°C. An apparent activation energy of 53.5 kcal per mole was obtained for the overall diffusion process. Efforts were made, unsuccessfully, to determine the growth kinetics of each of the intermetallic phases and the rate controlling step for the diffusion process. However, evidence indicates that a new intermetallic phase formed that may be stable over only a limited temperature range.

Pressure bonding was found to be an effective method of consistently producing coherent and adherent iridium coatings on small sheet samples of all of the refractory metals studied. Indications are that roll bonding can be adapted to coating large sheets of refractory metals with iridium. Insufficient knowledge of the chemistry and parameters that must be controlled in an electroplating operation prevented the production with any degree of consistency of adherent and coherent electrodeposited iridium coatings.

III. RESEARCH PROGRAM

This program, involving a study of the application of iridium coatings to the refractory metals (Ta, Nb, Mo, and W) and the suitability of such coatings as protection against oxidation at elevated temperatures, was concerned with four main areas of research. As shown diagrammatically in Figure 1, these areas consist of (1) sample preparation, (2) chemical compatibility studies, (3) mechanical compatibility studies, and (4) oxidation studies.

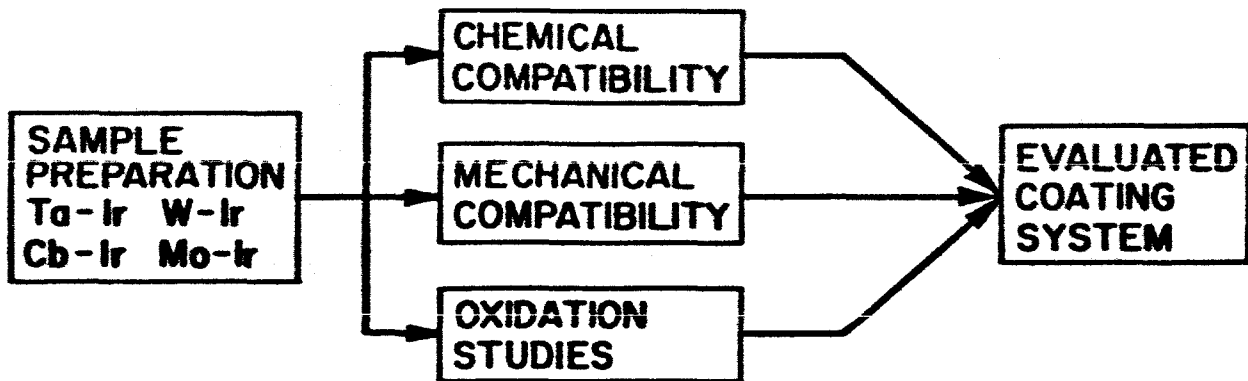

Figure 1. Diagrammatic Representation of the Research Program
N-7308

A. Sample Preparation

Iridium electrodeposited from a fused salt is the most promising of the coating techniques amenable to coating large, intricate geometrical shapes and, therefore, was selected as one of the main methods of sample preparation. Electroplating not only provided specimens for further study, but this coating method also allowed an assessment of the influence of process variables on obtaining adherent and coherent coatings.

In addition to electroplating, roll bonding and pressure bonding provided other means of obtaining specimens. Since roll bonding often results in preferred crystallite orientation, this method of composite fabrication may alter the physical and chemical characteristics of the coating-substrate system. In addition, the latter methods are particularly amenable to the fabrication of coated sheets. Since many test specimens were required, all three methods of sample preparation were used.

B. Chemical Compatibility

The character of the interface between coating and substrate was established by optical metallographical means. This work established

the extent of interdiffusion and intermetallic phase formation as a function of time and temperature for the Ta-Ir system. Although unalloyed iridium is impermeable to oxygen, the behavior of intermetallic phases and the influence of interdiffusion on the oxidation resistance of the iridium was not known.

C. Mechanical Compatibility

The strength of the coating substrate bond was determined qualitatively at room temperature with a micro-bend tester.

D. Oxidation Studies

For oxidation studies, both furnace and torch heating were used in general accordance with Materials Advisory Board specifications outlined in report MAB-201-M.

IV. EXPERIMENTAL

A. Materials

The high purity iridium sheet used in these experiments was obtained from Engelhard Industries, Incorporated. Sheet thicknesses of 0.005, 0.010, 0.020, and 0.040-inch were used, depending on the specific application.

The tantalum and niobium ($\frac{1}{4}$ -inch diameter rods and 0.005-inch and 0.020-inch thick sheet) were purchased from the Stellite Division of Union Carbide Corporation. Molybdenum and tungsten sheet (0.005 and 0.020-inch thick) were purchased from the Fansteel Metallurgical Corporation.

The sodium and potassium cyanides were high purity analytical reagent grades.

B. Sample Preparation

Emphasis was placed on preparing iridium-coated samples by electrodeposition from a fused salt electrolyte. However, because coherent and adherent deposits could not be obtained consistently, samples were also prepared by roll bonding, pressure bonding, and by the electrodeposition of niobium on iridium and tantalum on iridium. The alternate coating methods were also used to provide assurance that a "representative" coating-substrate system would be examined.

1. Fused Salt Electrodeposition of Iridium

The fused salt system developed by Withers and Ritt⁽¹⁾ for the electrodeposition of iridium on nickel and/or gold was used. A schematic diagram of the apparatus used is shown in Figure 2. The recrystallized alumina crucible (3 1/2 inches outside diameter by 6 inches high) contained the 70 w/o sodium cyanide--30 w/o potassium cyanide molten salt. Granulated alumina was used as insulation between the alumina crucible, the steel jacket, and the furnace.

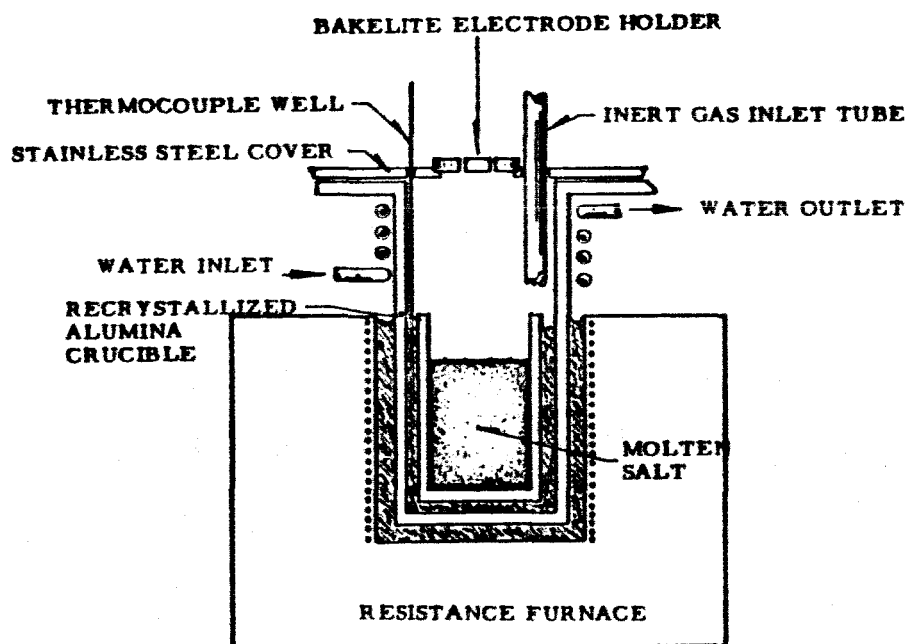

Figure 2. Schematic of Iridium Electrodeposition Apparatus
(Not to Scale)

N-6711

Initially, the cell was operated with the bath exposed to the ambient atmosphere. Later, to minimize oxidation and moisture pickup, an argon atmosphere was maintained inside the stainless steel enclosure. The temperature of the bath was determined by means of a Chromel-Alumel thermocouple positioned between the alumina crucible and steel enclosure. The molten bath temperature was maintained around 600°C during the plating operation.

Anodes for the molten salt bath consisted mainly of strips of iridium about $\frac{3}{8}$ inch wide. The cathodes consisted of 20-mil sheet and $\frac{1}{4}$ -inch diameter rods of tantalum, niobium, tungsten, and molybdenum. For most plating operations, both electrodes were positioned in the cell by means of graphite rods inserted through Bakelite or Teflon holders which were supported and centered above the molten bath by the stainless steel enclosure cover.

A solid-state power source capable of supplying direct current of 10 to 1000 ma was used for plating. To charge the molten bath with iridium, alternating current was passed through two iridium electrodes for a day or two. It later became evident that alternating current and two iridium electrodes were not necessary, since the anode efficiency always tended to be much higher than the cathode efficiency. Therefore, during the bath conditioning treatment, which consisted of electroplating using spectroscopically pure graphite rods as anodes until a coherent iridium deposit was obtained, the bath was also being charged with iridium. As soon as a satisfactory coating was obtained on the graphite rods, the refractory metal substrates were immersed in the bath.

Since adherence of the coating to the substrate can be strongly influenced by the prior substrate surface preparation, various substrate preparations were used. The substrate surface preparations are discussed in Section V, A, 2.

2. Roll Bonding

Roll bonding of iridium to tantalum and niobium was performed using the Stellite Division facilities at Kokomo, Indiana. The substrates, 0.020-inch x $\frac{1}{4}$ -inch x 1-inch, were sandwiched in "Hastelloy" Alloy X "cans" which

were evacuated and welded. Rolling was done at 1200°C with reheats after each pass through the mill. A single rolling direction was maintained. The reduction in thickness of the "cans" was between 25 and 35 per cent.

In the first two cans, alumina was sprinkled between the Hastelloy can and the specimens to prevent bonding of the samples to the "can." In a subsequent run, graphite foil was used as the spacer material.

3. Pressure Bonding

Vacuum hot-pressing techniques were also used to prepare specimens in picture-frame type composites (Figures 3a and 3b). Initially, the picture-frame composite consisted of a $\frac{5}{8}$ -inch diameter x 0.005-inch thick substrate disk sandwiched between two $\frac{3}{4}$ -inch diameter x 0.005-inch thick iridium disks with the iridium "picture frame" around the substrate disk (Figure 3a). This geometry was later modified to a square composite containing a cylindrical insert (Figure 3b), a design which allowed additional iridium protection at the edges and facilitated suspension of the specimens in the oxidation test apparatus.

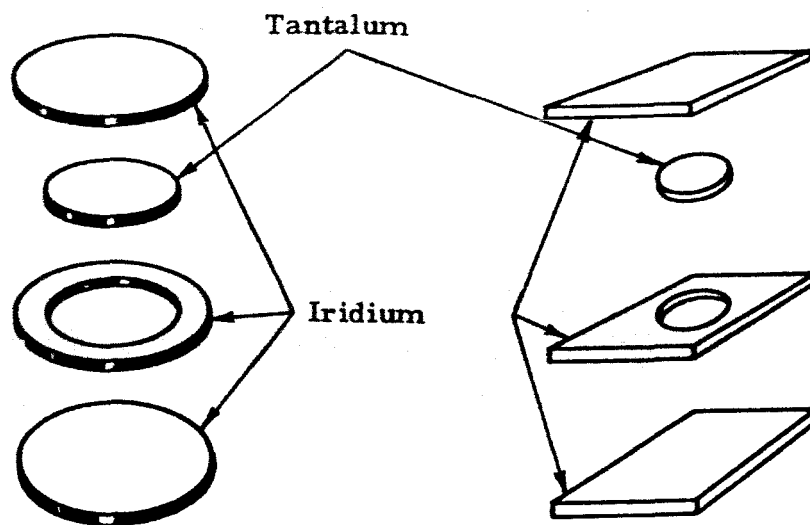

Figure 3a

Figure 3b

Figure 3. Schematic of Picture-Frame Composites Prepared for Pressure Bonding

N-7839

The composites were hot pressed at 1200°C at an ambient pressure of less than 0.3 torr. A pressure of 2700 lbs/in² was applied for one hour. The die and plunger were machined from Union Carbide Corporation, Grade ATJ Stock. As many as four composites were hot pressed simultaneously by inserting Union Carbide 'Grafoil' as a separator between each composite.

4. Electrodeposition of Refractory Metals

Several samples of ten-mil thick iridium sheet were electroplated with either niobium or tantalum by the techniques developed by Mellors and Senderoff⁽²⁾ of this Laboratory. Coherent and adherent deposits of the refractory metals were formed by the electrolysis in molten fluoride baths.

C. Sample Evaluation Techniques

1. Diffusion Studies

Specimens prepared by electroplating iridium on the substrate metal, by the reverse process, and by pressure-bonding techniques were used for preparing diffusion couples. Most specimens were heated under vacuum to the desired temperature (in the apparatus shown in Figure 4), held at temperature for a predetermined length of time, and then furnace cooled to room temperature. Some specimens were preheated to establish a good chemical bond prior to annealing. After the specimens were subjected to a particular heat treatment, they were metallographically polished on an edge showing the coating, the substrate metal, and the reaction zone. The thickness of the reaction zone was then determined from photomicrographs and by direct measurement using a Tukon Hardness Tester with a calibrated eyepiece. Because of irregularities in the reaction zone boundary, all measurements of thickness represent an average value of several determinations. A single measurement by either method was reproducible to within ± 0.4 micron.

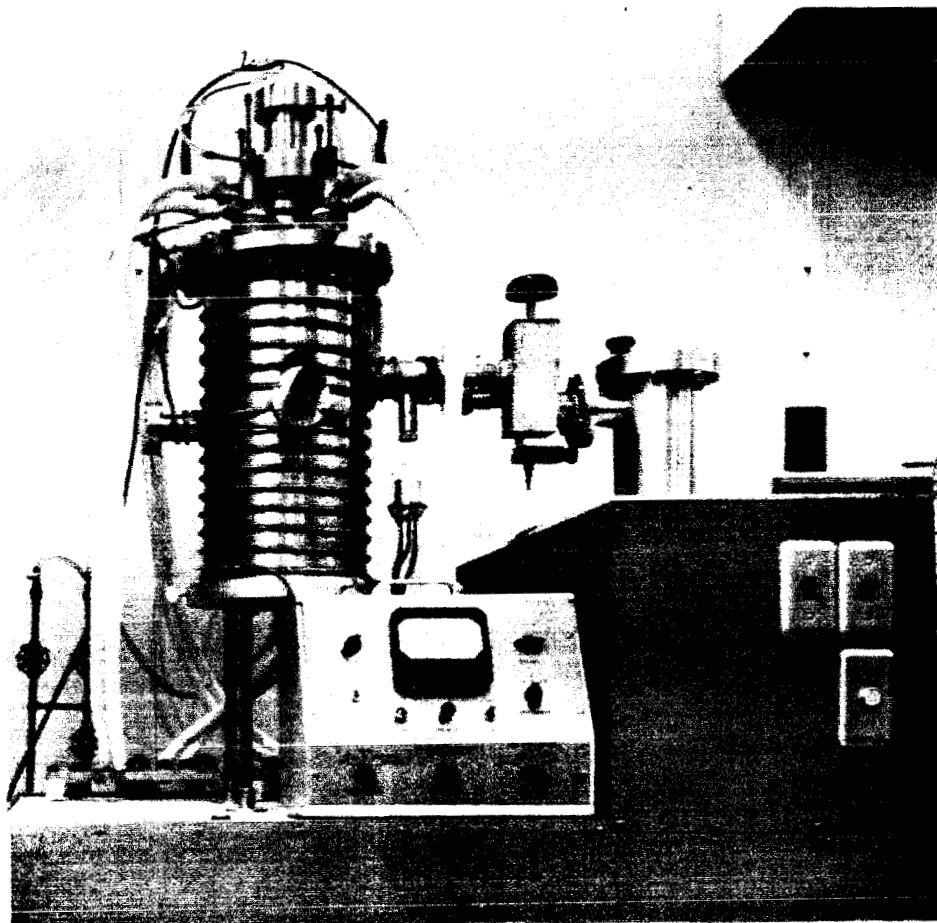

Figure 4. Vacuum Annealing Apparatus

N-6405

Normally, thirty minutes are required to attain a temperature of 1200°C in the apparatus shown in Figure 4. In order to determine the thickness of the diffusion zone resulting from heating and cooling the sample, a specimen (an iridium-tantalum couple) was heated to 1200°C , held at temperature for thirty minutes, and then furnace cooled. The resulting diffusion zone was less than one micron thick. Since only a few

minutes were required to heat the sample from 1200° to 1500°C, the heating and cooling periods were considered to have a negligible effect on annealing times at 1500°C.

An L and N optical pyrometer was used to measure specimen temperatures. The pyrometer was calibrated by means of a National Bureau of Standards calibrated tungsten ribbon lamp and a standard arc with sectorized disks as radiation sources. Corrections were made for glass absorption.

2. Mechanical Compatibility

To provide a better understanding of failure modes than can be gained from a simple bend test and to conserve material until coatings are considered representative, a fixture was constructed to allow direct observation of the microstructure as a bending stress was applied to a coating-substrate system. The microbend test, first proposed by Finn and Trojan⁽³⁾, involves bending a small specimen, approximately $\frac{1}{4}$ -inch x $\frac{1}{8}$ -inch x 1-inch, in the fixture shown in Figure 5 while viewing the metallographically prepared surface with a microscope. The entire stress gradient is visible, from maximum tension on the outer edge to maximum compression on the surface butting against the center loading pin.

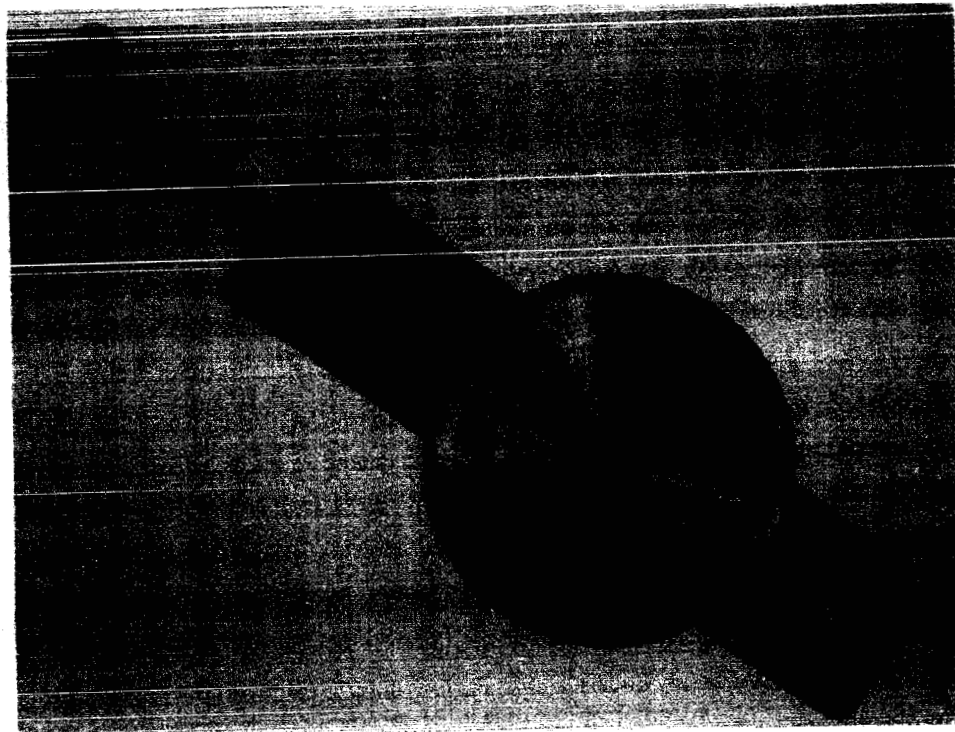

Figure 5. Microbend Fixture

N-6513

3. Oxidation Tests

Oxidation tests were conducted in an oxygen-methane flame and in an air furnace.

a. Oxygen-Methane Torch Tests

A National Welding Equipment Company Type 3A Blowpipe with an OX-4 tip was used in conducting the oxidation tests in an oxygen-methane flame. The gas flow rates were maintained at 11 CFH of oxygen and 5 CFH of methane (natural gas) with Brooks-Rotameters to assure an oxidizing environment. A 10-volume per cent excess of oxygen for the combustion of methane was used.

In a typical oxidation experiment, the test sample was supported in a vertical position by a zirconia holder which was slotted to accommodate the thickness of the sample. Graphite baffles were used to protect the flame from room drafts. Surface temperatures were regulated by varying the distance between the torch flame and test specimen, a distance which ranged from 0.5 to 5 inches. Temperatures were measured with a micro-optical pyrometer, which could be read to $\pm 2^{\circ}\text{C}$, by sighting on the side of the specimen which was opposite to the side exposed to the oxidizing flame. Corrections were made for the emissivity of iridium by comparing the temperature of a "black body" hole with the brightness temperature of the adjacent surface. The corrections were determined for both highly polished and matt iridium surfaces.

b. Air Furnace Tests

A high temperature thermogravimetric unit consisting of an Ajax Magnothermic Induction Furnace and an automatic recording balance was used to conduct oxidation tests in slow moving air (one volume change per minute). The furnace portion of the system is shown in Figure 6. A sample support (1) suspended from an automatic recording balance maintained the sample (2) in the center of an impervious alumina furnace liner tube (3). An alumina thermowell (4) and gas inlet tubes (5) were sealed to the bottom of the furnace liner tube with alumina cement (6). The entire assembly was insulated from a graphite susceptor (7) with graphite felt (8). A quartz envelope (9) was used to contain the felt. A thermowell, gas inlet, and a furnace flush inlet (10) were inserted in the bottom (11) of the quartz envelope and sealed with Sauereisen cement. Alumina plates (12) were used to enclose the tops of both the furnace liner and quartz envelope. The induction coil (13) was energized with a 6 KW Ajax Magnothermic spark gap converter.

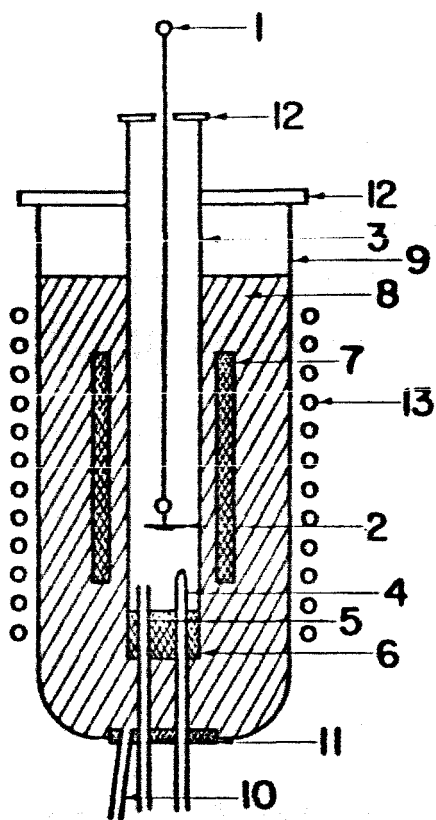

1. Sample support
2. Sample
3. McDanel impervious alumina tube
4. McDanel impervious alumina thermowell
5. McDanel impervious alumina gas inlet tube
6. Morganite 961 alumina cement
7. Graphite susceptor (grade ATJ)
8. Graphite felt (grade WDF) insulation
9. Amersil opaque quartz envelope
10. Quartz furnace flush tube
11. Sauereisen No. 1 cement
12. Sintered alumina plates
13. Ajax Northrup 309 Induction furnace powered with a 6 KW Type "C" converter

Figure 6. 2000°C TGA Furnace

N-6317

The automatic recording balance unit consisted of an Ainsworth Type BB balance, a Fisher Scientific Company balance recorder, and a Model 75 Fisher Recording Analytical Balance control unit.

c. Coating Recession Rate Determinations

Three methods of determining the recession of iridium were used:

Method 1

The first method consisted of measuring the cross-sectional dimensions of the components (coating, substrate, and diffusion zone) by metallographic techniques after oxidation. Figure 7 is a schematic of a specimen before and after oxidation, showing the iridium, the diffusion zone, and the tantalum thicknesses. The iridium thickness after oxidation was 3.4 mils, 1.2 mils of which were consumed by the diffusion

zone and 0.4 mil by oxidation. The outer iridium surface recession rate was 0.02 mil /hour for specimens oxidized at 1850°C.

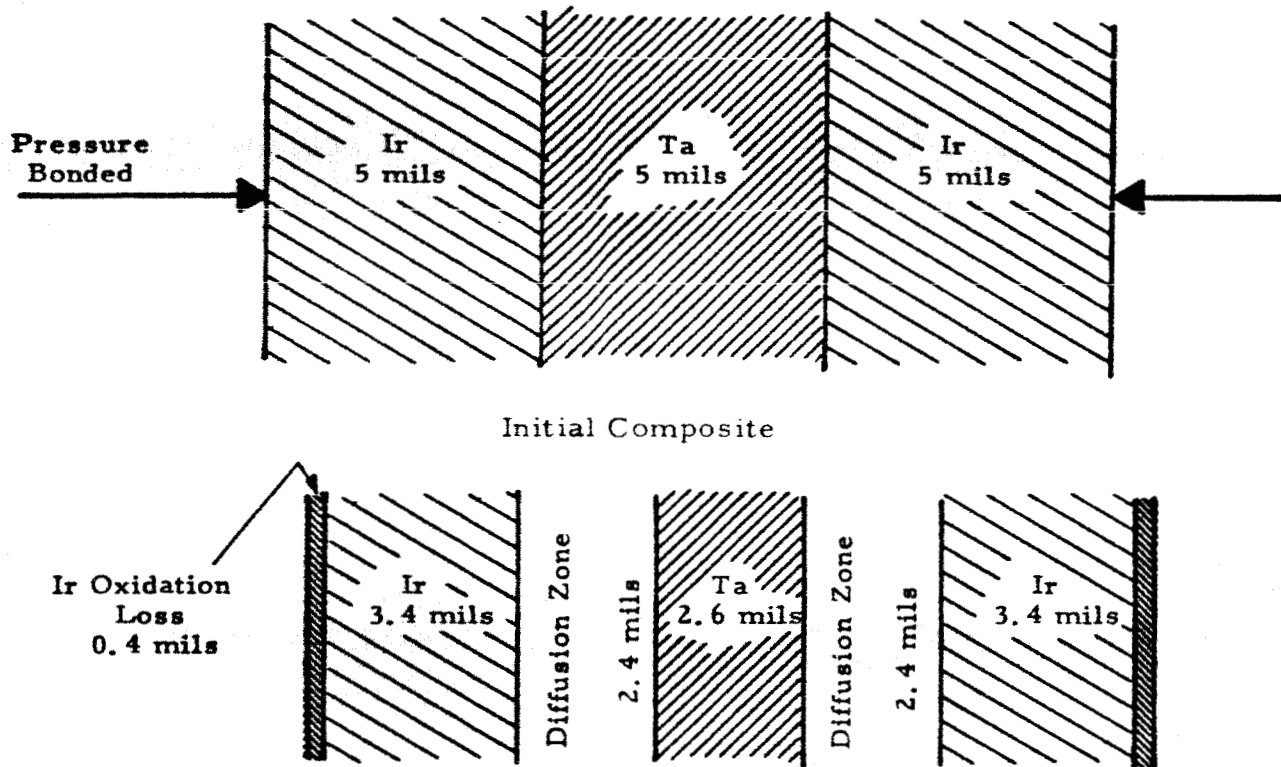

After 15 Hours in Slow Moving Air at 1850°C (3362°F)

Figure 7. Schematic of Ir-Ta Composite After Oxidation at 1850°C for 15 Hours

N-7840

Method II

The second method consisted of measuring an iridium portion of the composite where tantalum diffusion did not occur, i. e., at the ends of the composite where only the iridium-iridium bond is present. The thickness of the iridium at the ends of the composite prior to oxidation was 15 mils. After oxidation, the average thickness of 15 measurements was 14.2 mils, corresponding to an iridium decrease of 0.8 mil on each side of the specimen. Again, the iridium recession rate was 0.02 mil /hour for the 15 hour test.

Method III

The third method consisted of measuring the weight loss of the specimen as a function of time. In this case, the recession rate was determined by considering the weight loss, area, and density of iridium. For example, the weight loss of iridium per cm^2 of surface represents a certain thickness of the metal which can be calculated from the expression,

$$R = \frac{K}{d} \times \frac{390 \text{ mils cm}^2}{1 \text{ cm}^3} = 17.4 \times 10^{-3} K,$$

where R = the recession rate in mils/hour,

K = linear rate constant $\text{mg}/\text{cm}^2/\text{hr.}$,

and d = density of iridium = $22.42 \text{ g}/\text{cm}^3$.

A uniform weight loss of 10 mg per hour was obtained for the oxidation of the Ir-Ta composite at 1850°C for 15 hours. Since the surface area was 7.56 cm^2 , the recession rate was $1.32 \text{ mg}/\text{cm}^2/\text{hr.}$ Using the above equation, $R = 0.02 \text{ mil /hour}$.

4. Visual Examination

All coating substrate composites, regardless of the method of preparation, were examined for external flaws with the unaided eye and with a low-powered microscope. Specimens that could be sectioned, such as those used for studying diffusion effects and some of the electroplated samples, were metallographically polished and microscopically examined.

V. RESULTS AND DISCUSSION

A. Coating Methods

1. Pressure and Roll Bonding

Of the three coating methods used in this investigation, the pressure bonding method was the only one that consistently produced small sheets of the refractory metals coherently and adherently coated with iridium.

High temperature pressure bonding provided a reaction zone between the substrate and the coating that resulted in good adherence. Roll bonding should yield the same results as pressure bonding; however, the contact time of substrate metal to the iridium coating, while under pressure, is much shorter. The first two attempts at roll bonding resulted in adherence between iridium and tantalum, but not between iridium and niobium. The third attempt, in which the substrate metal was completely surrounded with iridium, failed. In the third attempt, "Grafoil" was used to prevent the samples from bonding to the "Hastalloy" alloy X can, instead of the alundum powder used in the prior attempts. Since the precise potentials of iridium as a high temperature protective coating for the refractory metals is still being investigated and since the roll bonding was not performed at this Laboratory, it was felt that continued experimentation with roll bonding was not warranted. However, roll bonding looks extremely promising for coating large sheets of the refractory metals with iridium. Pressure bonding is a relatively fast and reliable method of producing small sheet samples, since the parameters (temperature, pressure, and time-at-pressure) are easily controlled.

2. Fused-Salt Electrodeposition of Iridium

a. Substrate Preparation Prior to Electrodeposition

Improper substrate surface preparation prior to electroplating invariably results in an irregular coating which is often nonadherent. The inability to produce adherent iridium coatings on the refractory metals with any degree of consistency necessitated trying a variety of surface preparations. The following cleaning processes were tried singly and in combination: (1) degreasing with acetone, ether, or alcohol, (2) vacuum degassing at elevated temperatures, (3) mechanical abrasion, (4) applying a prior subcoat of iridium by the slurry dip and sinter technique, and (5) various chemical cleaning methods (e. g., acid dip, base dip, or anodic and cathodic etching). In addition, some of the substrates were subjected to the elaborate surface treatments recommended by the Defense Materials Information Center (DMIC Memorandum 35, October 9, 1959) "Procedures for Electroplating Coatings on Refractory Metals." Most of the cleaning methods tried provided some iridium-coated samples in which the iridium

was adherent. However, none of the above methods resulted consistently in the production of adherent coatings.

A method of surface preparation was developed and standardized for use on all of the substrate metals. This standardized method yielded results as good as or better than the above treatments, even though we were still not able consistently to produce adherent iridium coatings. The procedure involved (1) polishing the substrate metal surface with wet abrasion papers through 600 grit, (2) scrubbing with hot Alconox solution, (3) rinsing with distilled water, (4) dipping into a dilute sulfuric acid solution (7-8 per cent) to insure neutralization of a residual basic solution, (5) washing again with distilled water, and (6) washing with 95 per cent ethyl alcohol. The specimens were dried in air before being placed into the fused salt electroplating bath.

b. Cell Chemistry

The electroplating procedure was described in the experimental section of this report. Since none of the refractory metal surface preparations could be relied upon consistently to provide adherent iridium coatings, efforts were made to eliminate the introduction of impurities (e. g., oxygen and moisture) into the electrolyte.

Interactions of the refractory metals with impurities in the hot electrolyte may also cause nonadherence of the electrodeposited coatings. An extremely dark layer between the coating and substrate often was present on those specimens on which the iridium did not adhere. This dark barrier layer may very likely have formed as a result of chemical reactions between the substrate metals and chemical species present in the molten salt. The possibility also exists that the current density exceeded the diffusion limited current, and alkali metals were deposited together with iridium. The deposition of alkali metals would have a pronounced effect on the deposits, producing powders, dendrites, and even slimes. Both X-ray diffraction and X-ray fluorescence methods of analyses were used to examine the dark barrier layer that formed on tantalum. Because of the very small thickness of this layer, no positive identification of this material could be made.

Several precautions were taken to prevent the contamination of the substrate metals by impurities present in the fused salt bath. These precautions were: (1) purging the bath with dry, high purity argon to assist in the removal of water which is a commonly known contaminant in fused salt baths even at high temperatures, (2) pre-electrolyzing using high purity graphite as cathodes to remove cation impurities, and (3) precoating the substrate metal with iridium by slurry coating and sintering to provide a surface which would be inert to attack by contaminants in the fused salt bath. Although these precautions and prior surface treatment of the substrate did in many instances improve the coating, adherent coatings were still not consistently produced.

Efforts were made to chemically analyze portions of the electrolyte of an operating cell to correlate the visual appearance of the electrolyte with the appearance of the deposit obtained, the total iridium content, and the iridium mean valence in the electrolyte. Bright metallic coherent deposits were generally obtained when the electrolyte was a transparent dark red color. An electrolyte that was light red to straw colored usually produced a deposit that was dull gray, rough, and quite often nonadherent. Apparently, then, the transparent dark red color indicates that the iridium in the electrolyte is in the proper valence state and the redder the bath, the higher the concentration of the iridium complex in the bath. It was observed time-and-again that, upon standing overnight at the plating temperature, the electrolyte changed from a dark to a light red. Often, on standing at plating temperature over a weekend, the electrolyte changed from red to straw yellow. Once an electrolyte became straw yellow, it never again produced a bright metallic coherent deposit.

A literature survey by the analytical group at this Laboratory failed to disclose procedures that could be used directly to determine the total iridium content and the mean valence of the iridium in the electrolyte. From the literature on iridium cyanide complexes, it was assumed that the $\text{Ir (II)} \rightarrow \text{Ir(III)}$ reaction could be followed potentiometrically as in the case of $\text{Fe (II)} \rightarrow \text{Fe(III)}$. Iridium forms divalent⁽⁴⁾ and trivalent cyanide complexes which are analogous to the ferro-ferric cyanides. Tetravalent

and univalent iridium as a cyanide complex are unknown. J. Kleinberg⁽⁵⁾ lists a platinum-cyanide complex in which platinum has a zero valence. This compound, when pure, disproportionates in water to yield, among other substances, platinum metal. On the basis of the known valences of iridium in cyanide complexes, one could suggest a mean valence of three or lower in the electrolyte.

Preliminary chemical analysis indicates that electrolyte samples that were colored straw yellow or white may contain iridium with a mean valence of three, whereas samples colored dark red had a calculated mean iridium valence of two or less. One electrolyte sample actually indicated a mean valence close to one. The preliminary analysis indicates that iridium must be maintained in a low valency state. The thermodynamic stability of the complex iridium anion responsible for producing a coherent deposit seems to be either on the threshold of instability (i. e., it has too large a dissociation constant) or it readily oxidizes to a higher valence state. It is therefore necessary to avoid all types of oxidizing conditions, such as oxygen and moisture contamination of the electrolyte or insufficient anode area, that may raise the valence of iridium. The data obtained thus far are insufficient to distinguish between electrolyte deterioration due to (1) a gradual build-up of impurities to a critical level that prohibits the deposition of a coherent iridium deposit, or (2) the thermodynamic instability of the iridium complex giving rise to the noncoherent deposit. It may be possible to overcome thermodynamic instability by continuous electrolysis. However, achieving the proper cell conditions necessary for the consistent production of coherent iridium deposits does not necessarily mean that the deposits obtained will be adherent. The presence of moisture or oxygen in the hot electrolyte cannot only affect the valence state of the iridium in the complex anion, but it can also oxidize the substrate metal surface and prevent a coherent iridium deposit from being adherent.

To overcome some of the difficulties experienced, a new cell is being constructed that will prevent atmospheric contamination of the electrolyte. The new cell will contain two chambers separated by a gate valve. With the gate valve closed, the chamber containing the hot

electrolyte may be kept under an inert atmosphere while the electrodes are inserted or removed through the upper chamber. When new electrodes are introduced, it will be possible to evacuate and/or purge the upper chamber, then open the gate valve and lower the electrodes into the electrolyte.

Several experiments were conducted using iridium as both the anode and cathode. The objects of these experiments were to determine (1) the steady state conditions of an operating cell, (2) the anode and cathode efficiencies, and (3) the anode and cathode reactions occurring on the basis of the number of electrons involved. To date, insufficient data have been obtained to permit a complete definition of the system. However, some observations can be made. When a new bath is started (the fused salts contain no iridium), both the anode and cathode lose weight even though a current is present. The anode initially oxidized, adding iridium to the electrolyte (as a complex compound) with a valence of two. A negative cathode efficiency may indicate that not only was the cathode reducing the valence of iridium in the electrolyte, but it also may have acted like a battery, the emf of which opposed that of the power source. The net result was a loss of iridium at both the anode and cathode, an increase in the iridium content of the bath, and a very low cell emf. As the iridium concentration in the bath increases, calculations indicate that four or five electron reactions may be occurring. At the anode, iridium with a valence of two may still be going into the bath, and, at the same time the divalent iridium, is being oxidized to a higher valence state. At the cathode, the higher valent iridium is reduced to the divalent state and, in a step-wise fashion, the divalent iridium is reduced to the free metal state. Calculations also show that the cathode efficiency was always less than that of the anode for any assumed valence state. Also, steady-state conditions were never achieved. Explanations of this behavior may be: (1) the baths may not have been fully saturated, (2) these characteristics are typical of this particular salt system, (3) the operating parameters of temperature, current density, or anode to cathode area ratio chosen on the basis of our work and that of Withers and Ritt⁽¹⁾ may not lead to the establishment of a

steady-state condition, or (4) there may be a gradual increase in the contaminant concentration of the electrolyte to a detrimental level. Since the operation of any bath for a period of time always led to bubbling at both electrodes, oxygen and/or moisture build-up in the electrolyte are very probably the most serious problems.

c. Voltage-Current Characteristics of the Fused Salt Cell

A constant voltage, direct current power source was used to obtain the voltage-current characteristic curve for the fused salt plating bath. Although the method used for determining the current was not very precise (a standard cell is normally used instead of an ammeter), the results give an approximate indication of the cell potential limits within which the desired results would be expected to occur. The results, which are applicable only to our specific plating operation, are shown in Figures 8 and 9 for the electrodeposition of iridium on copper and tantalum, respectively. The results indicate that the cell potential range needed to produce an iridium coating that increased in thickness with time was between approximately 0.4 and 1.5 volts. Above 1.5 volts, an increase in the current may be due to the motion of charged species other than the iridium complex; in addition, the cell potential may be sufficient to decompose the electrolyte. Within 0.4 and 1.5 volts, the higher the cell potential, the greater the current density and, therefore, the deposition rate. The nature of the deposit (such as the formation of dendrites or a porous coating) may vary considerably with deposition rate; and, as reported by Withers and Ritt⁽¹⁾ the cathode efficiency is strongly dependent upon current density.

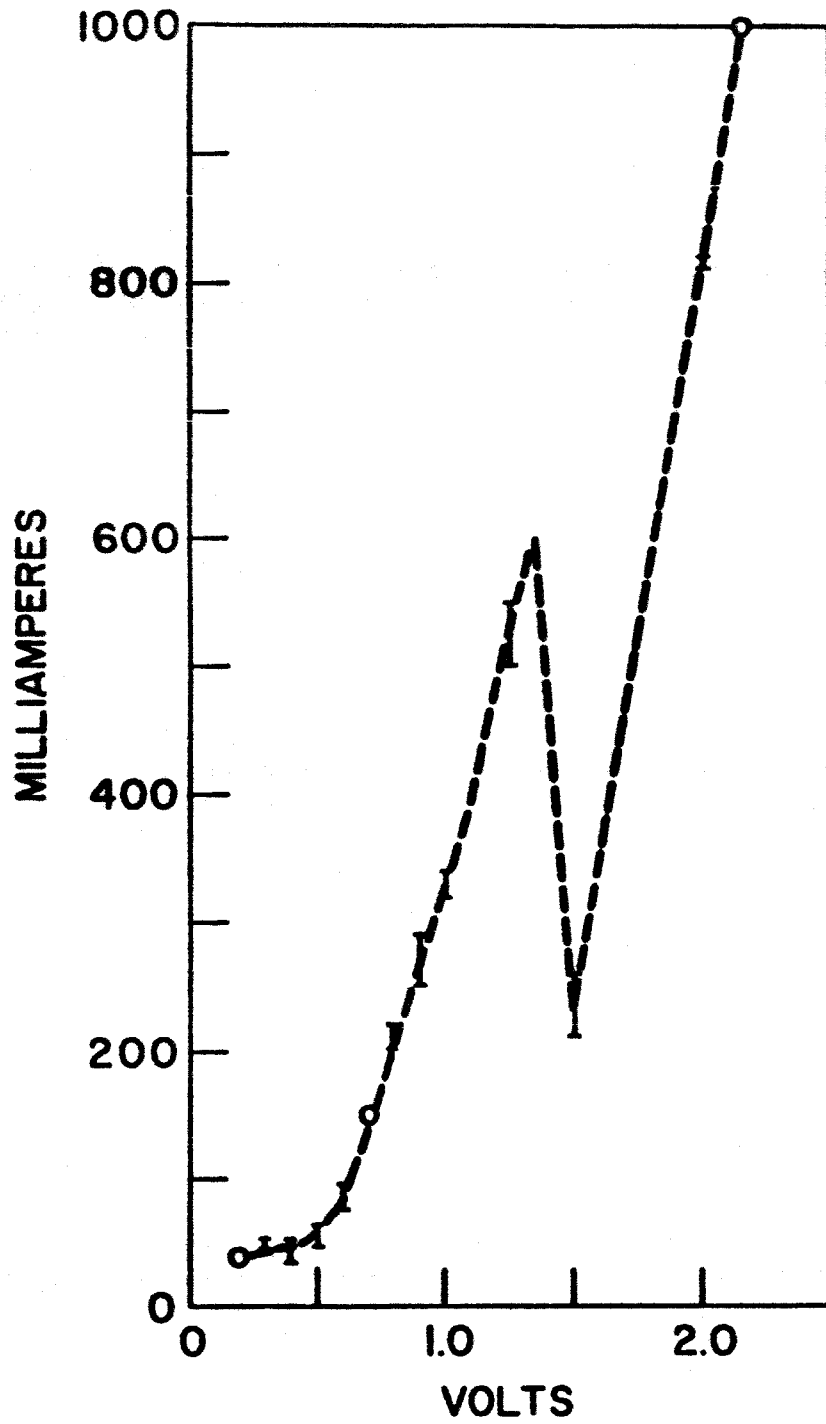

Figure 8. Voltage-Current Characteristic, Copper Substrate

N-7096

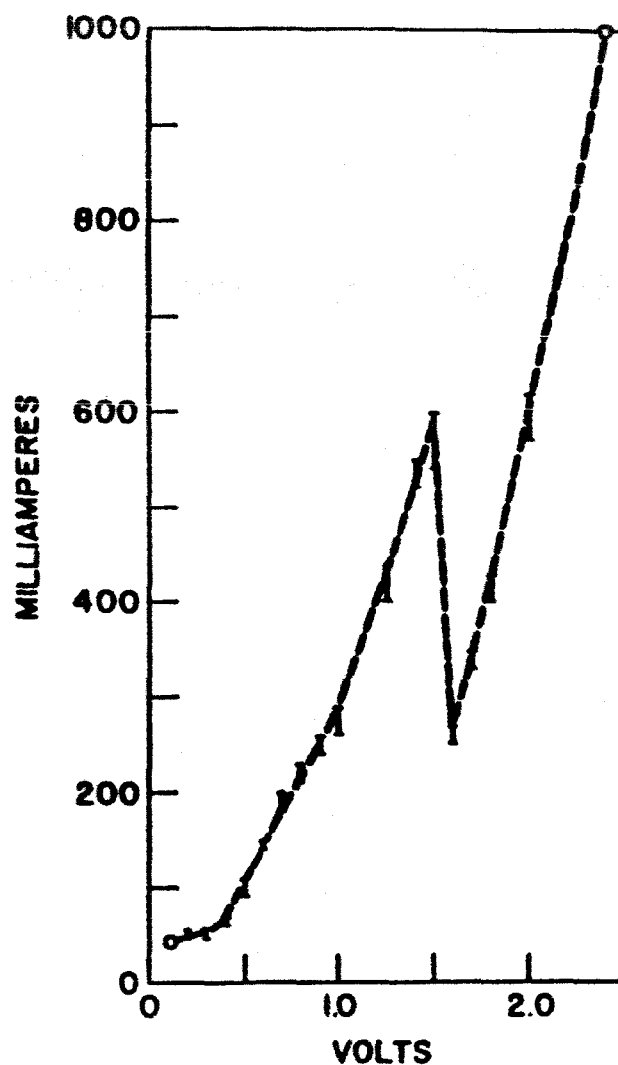

Figure 9. Voltage-Current Characteristic Curve, Tantalum Substrate
N-7095

B. Diffusion Studies

The rate of growth of the reaction zone for iridium in contact with tantalum was determined at various temperatures in the range 1200° to 1655°C. The data are summarized in Table I. Figure 10 is a graph of the square of the total reaction zone thickness versus time. Since the data points at each of the temperatures can be represented by straight lines, the reaction rate obeys a parabolic rate law, and the reaction zone growth is diffusion controlled. The straight lines shown in Figure 10

represent a least-squares treatment of the data excluding the data at 1570°C and 1655°C), and the slopes of the lines represent the rate of growth of the reaction zone at each temperature. From the reaction zone temperature dependent data, shown in Figure 11 as an Arrhenius plot, apparent activation energy of 53.5 kcal per mole is obtained for the total diffusion process.

TABLE I
HIGH TEMPERATURE DIFFUSION DATA FOR
THE IRIIDIUM-TANTALUM SYSTEM

Annealing Time Minutes	Total Diffusion Zone Thickness, Microns	Growth Rate Microns ² /Minute
<u>1200°C</u>		
30	1.0	} 0.0523*
60	1.5	
120	2.13	
180	3.0	
240	4.0	
<u>1300°C</u>		
60	3.2	} 0.177*
120	3.9	
180	5.4	
240	6.6	
<u>1400°C</u>		
5	2.0	} 0.455*
15	2.3	
30	3.6	
90	6.4	
<u>1500°C</u>		
5	2.8	} 1.10*
15	3.9	
30	6.9	
90	9.8	
<u>1570°C</u>		
120	19.0	} 2.2**
240	25.0	
<u>1600°C</u>		
5	3.9	} 2.84*
15	6.4	
30	9.8	
90	16.0	
<u>1655°C</u>		
30	20.5	} 4.4**
60	23.5	

* Least Squares Calculations
** Average Values

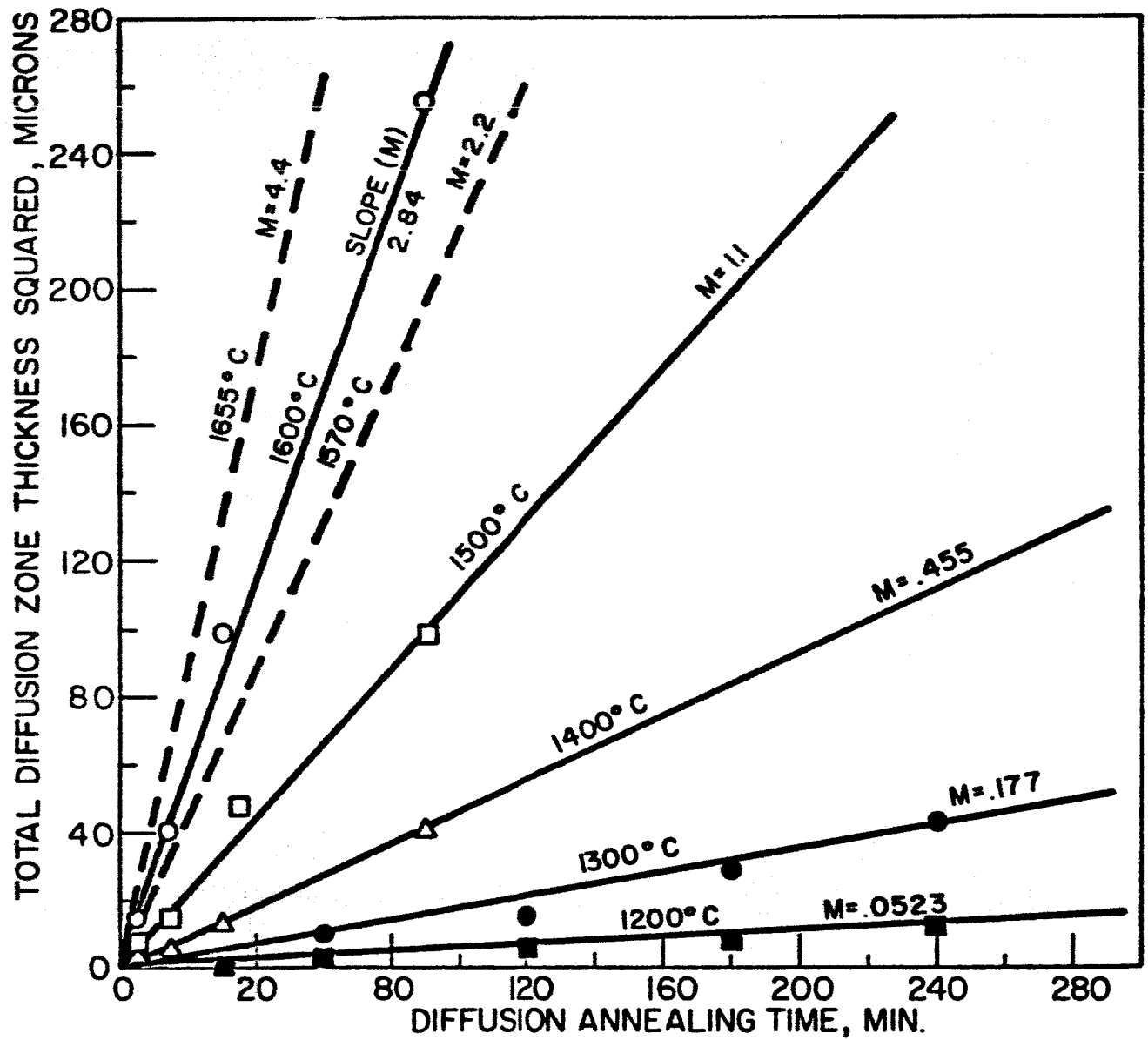

Figure 10. Reaction Zone Growth as a Function of Time, Ta-Ir System
N-7842

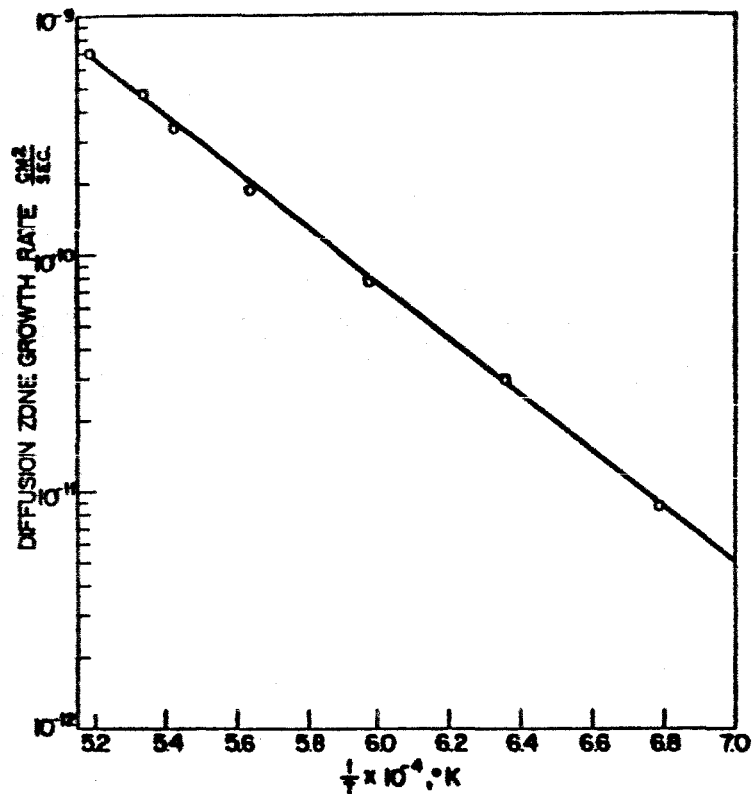

Figure 11. Log Reaction Zone Growth Rate Versus Reciprocal, Degrees Kelvin

N-7841

The distribution of the intermetallic phases comprising the total reaction zone, illustrated in the photomicrograph of Figure 12, is of a tantalum iridium sample. The metallographic specimen was electro-etched in hydrochloric acid at five volts D. C. in accordance with the method used by Rapperport et al. ⁽⁶⁾ Four phases are discernable between the light layer of iridium and the dark layer of tantalum in keeping with the reported phase diagram. However, specimens annealed at 1570° and 1655°C indicate that a new intermediate phase may be present that grows at the expense of the α_2 phase. At 1570° and 1655°C, the duration of the anneals were chosen to provide intermetallic phases sufficiently thick to be measurable. Although the etching and/or staining techniques needed to reveal in a manner which is reproducible, the individual intermetallic phases have not been obtained, indications are that a new, or fifth, intermediate phase may be present.

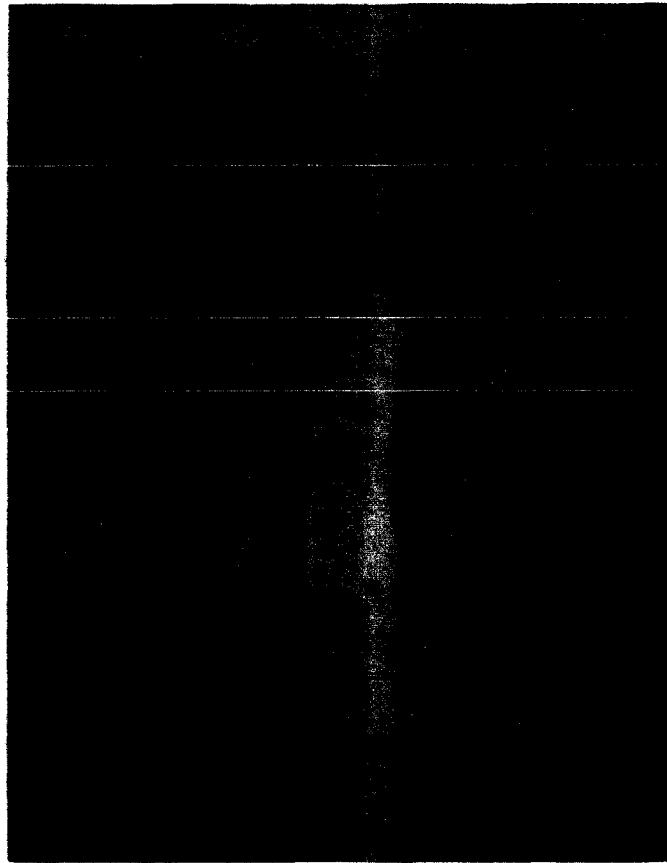

Figure 12. Representative Diffusion Annealed Tantalum-Iridium Sample
750 X Magnification

N-7858

Efforts were made, unsuccessfully, to determine the growth kinetics of each of the intermetallic phases and the rate controlling step for the diffusion process. Traversing polished cross sections of annealed specimens with a microhardness tester failed to reveal the thickness of the individual phases. Similarly, improvements in the etching and/or staining techniques are needed before the individual phases can be measured in a reproducible manner by metallographic techniques. Figures 13 and 14 show the change in thickness of the reported intermetallic phases as a function of

time at 1570° and 1655°C, respectively. The α_1 , σ , and $TaIr_3$ phases increased in thickness with time-at-temperature. However, the α_2 phase was observed to be decreasing in thickness with time at both temperatures. Whether the decrease in thickness of α_2 with time is an artifact, produced by the polishing and etching techniques employed, or is caused by the formation of a newly discovered intermetallic phase is presently unresolved. Microscopic examination of some of the specimens indicates that a new intermetallic phase is formed that may be stable over only a limited temperature range. Although no attempt was made to examine the specimens with a microprobe, microprobe analysis may simplify measuring the positions of the intermetallic phase boundaries and identification of the individual phases.

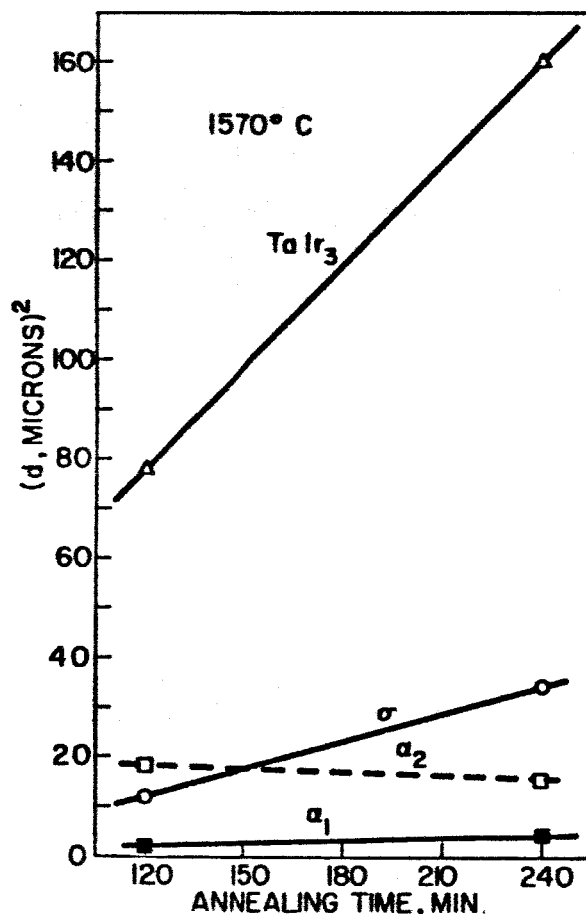

Figure 13. Intermetallic Phase Growth as a Function of Time at 1570°C
N-8695

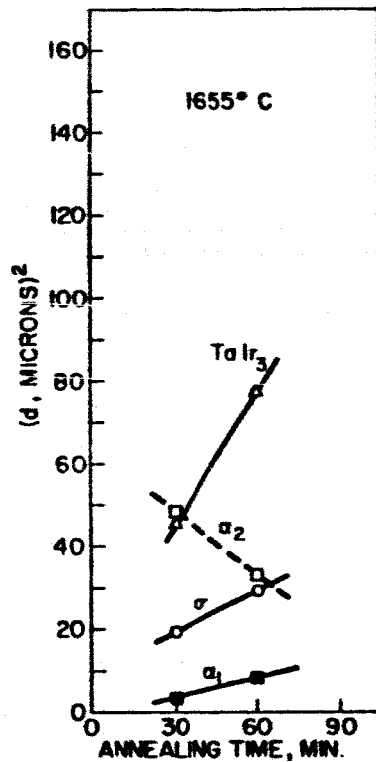

Figure 14. Intermetallic Phase Growth as a Function of Time at 1670°C
N-8810

C. Mechanical Compatibility

The microbend test fixture was used to evaluate the mechanical compatibility of the refractory metals coated with iridium. Differences were observed in the mechanical behavior between specimens prepared by roll bonding and pressure-bonded and electroplated samples.

A tantalum-iridium specimen that was reduced 20 per cent by hot rolling was sectioned to provide two specimens for microbend tests. One specimen was tested in the as-rolled condition, and the other was vacuum annealed for four hours at 1500°C before testing. Annealing produced a diffusion zone of approximately 15 microns and recrystallized the elongated iridium grains produced by rolling. The specimen in the as-rolled condition was bent to an angle greater than 90 degrees, and no cracks were observed in the coating or the substrate. The annealed specimen

developed cracks in the diffusion zone when a very small load was applied. However, in spite of the diffusion zone cracks, bending was continued to an angle of approximately 21 degrees before the iridium coating began to fracture. The cracks that appeared in the iridium initiated on the side of maximum tension and propagated along the grain boundaries. Similarly, a strip of iridium which was hot-rolled with niobium but which did not adhere to the niobium was bent to an angle greater than 90 degrees without the formation of observable cracks.

Pressure bonded specimens containing five mil iridium coatings on molybdenum, tungsten, and niobium were tested in the "as pressure bonded" condition, and one iridium-on-molybdenum specimen was tested after an oxidation test at 1800°C for 62 hours in the air furnace. Similarly, electroplated specimens were tested in the as-plated condition. In all of the specimens, microcracks started on the side of maximum tension (the iridium-air interface) and propagated through the iridium coating, through the reaction zone, and finally, into the substrate metal. The bend angle at which the tests were discontinued was ten degrees or less.

Since the iridium coatings in the pressure bonded and electroplated specimens fractured at very small bend angles, no specimens were subjected to tests in the standard-sized bend tester. The tests performed demonstrated the extreme brittle behavior of iridium. The formation of a reaction zone between the substrate metal and the iridium coating does not drastically alter the mechanical behavior of a composite.

D. Oxidation Tests

Oxidation in slow moving air (one furnace volume change of air per minute) was conducted on the substrate metals coated with iridium by electrodeposition and by pressure bonding. The electroplated coatings ranged in thickness from 2.5 to 3 mils, and the pressure bonded coatings were five mils thick. Small sheet specimens were oxidized at temperatures ranging from 1100°C to 1850°C. The oxidation behavior was followed by continuously recording the specimen weight change as a function of time. Coating failures were denoted by changes in the oxidation rates. Two

separate tests were performed on each of the coated substrate metals: (1) oxidation continued until failure, and (2) oxidation discontinued after 15 hours or longer but before the coating failed. The duration test provided information on the life expectancy of the coating at temperatures above 1800°C. Oxidation tests discontinued before failure provided data on the recession rate of iridium under the specific conditions of these tests and provided specimens that could be sectioned and analyzed metallographically. Metallographic examination of specimens which did not fail provided data on the rates of growth of the reaction zones between iridium and the substrate metals in addition to permitting an examination of the substrate metals for indications of internal oxidation prior to failure.

1. Air Furnace Oxidation of Pressure-Bonded Samples

a. Results of Duration-to-Failure Tests

Efforts were made to oxidize one composite from each of the systems investigated until failure above 1800°C. The five mil iridium coating protected tantalum and molybdenum at 1850°C for 51 and 76 hours, respectively. Duration-to-failure time for the iridium-niobium samples tested at 1800°C was 36 hours. Since the reaction zone growth rate in the iridium-niobium system was significantly greater than the growth rates for the other systems, the reduced life was expected. The lowest reaction zone growth rate observed was in the iridium-tungsten system. The air furnace oxidation test of an iridium-tungsten specimen resulted in no failure after exposure for 117 hours at 1850°C. Metallographic examination of the cross-sectional specimen after the 117 hour exposure disclosed no signs of oxidation in the tungsten substrate. The total reaction zone measured 45 μ and consisted of two phases tentatively identified as the σ and ϵ phases reported by Rapperport et al. ⁽⁶⁾

The relationship between reaction zone growth rate and duration-to-failure life observed in these tests indicates the importance of future diffusion studies with respect to the reaction zone.

b. Results of 15-Hour Tests

(1) Iridium-Tantalum System

A total reaction zone thickness of 61.5 microns (2.42 mils) was revealed by metallography after air furnace testing for 15 hours at 1850°C. Four (possibly five) phases were observed in the reaction zone microstructure. The four compounds reported in the literature⁽⁶⁾ were tentatively identified as σ , α_1 , α_2 , and $TaIr_3$. A new phase was observed between σ and α_1 , that could be observed only by staining electrolytically for long periods of time. This new phase was also observed in diffusion-annealed specimens but was only present when the annealing temperature exceeded 1570°C. A similar high temperature phase was also tentatively identified by Rapperport, et al.⁽⁶⁾ in the investigation of the Ta-Rh equilibrium diagram.

Iridium recession due to oxidation during the 15-hour air furnace test at 1850°C was calculated to be .024 mil/hour. Metallographic analyses referred to as Method I in Section IV, C of this report was used to make the calculation. Iridium loss to the reaction zone by diffusion occurred at the rate of .082 mil/hour. Iridium diffusing to the reaction zone during hot pressing was considered negligible, since examination of specimens in the "as pressure bonded" condition resulted in reaction zones less than a micron thick. The first pressure bonded specimen reported previously (see NASw-1030, Progress Report No. 3) having a reaction zone of 16 microns resulted from too high a pressing temperature and holding time.

Metallographic examination of the specimen after the air furnace test revealed no internal oxidation to the tantalum substrate.

(2) Iridium-Tungsten System

A total reaction zone thickness of 24.5 μ (0.97 mil) was observed by metallography after air furnace testing for 15 hours at 1850°C. Two phases were revealed after electrolytic etching which correspond to the σ and ϵ phases reported by Rapperport et al.⁽⁶⁾

The iridium recession rate calculated by the weight change before and after exposure was .066 mil/hour. Metallography revealed that all the total diffusion zone (0.97 mil) was a result of Ir loss, since the thickness of

the W substrate was unchanged. Therefore, the rate of iridium lost to the diffusion zone was .065 mil/hour. The slightly higher rate obtained by weight change is probably due to the heavier tungsten compounds being formed at the reaction zone which would affect the weight change.

Metallography revealed no internal oxidation of the tungsten substrate after air furnace testing.

(3) Iridium-Niobium System

A reaction zone thickness of 66.6 microns (2.62 mils) resulted from the 15-hour exposure at 1800°C. Difficulties in preparing the metallographic specimen and etching techniques failed to reveal the phases present in the reaction zone.

The iridium recession rate calculated by the weight change before and after the oxidation test was 0.034 mil/hour. Metallographic techniques revealed that the Ir was being consumed by the reaction zone at the rate of 0.17 mil /hour.

A metallographic examination of the cross-sectioned specimen after oxidizing revealed no internal oxidation of the Nb substrate.

2. Air Furnace Oxidation of Electroplated Samples

All of the electroplated specimens showed initial failure during high temperature oxidation tests at a small fraction of the time estimated for the coating life. Premature failure was attributed to lack of adherence of the coatings to the substrate metals, since submerging the coated specimens in hot acids (e. g., 1:1 HNO₃ with HF solution added) indicated that the specimens had coherent coatings void of pinholes and microcracks. Exposure of the electroplated specimens to elevated temperatures, under air or argon atmospheres, usually produced blisters that could easily rupture. Since iridium coatings are not self-healing, localized coating failure quickly results in complete oxidation of the substrate metal. However, it was observed that when the substrate oxidation products were volatile, complete oxidation of the substrate metal left a hollow shell of iridium having the same shape it had prior to oxidation. This study strongly indicates that annealing the coated specimens to provide a diffusion bond will

eliminate specimen failure due to blister formation.

3. Summary of Air Furnace Oxidation Test Results

The five-mil-thick iridium coatings pressure bonded to the substrate metals provided complete oxidation protection for from 36 to at least 117 hours at temperatures from 1800° to 1850°C. Test temperatures of 1850°C were used for the Ir-Mo, Ir-W, and Ir-Ta composites and 1800°C for the Ir-Nb composite (the binary system contains a eutectic at about 1840°C). The results of the air furnace tests are tabulated in Table II.

TABLE II
AIR FURNACE OXIDATION OF PRESSURE-BONDED COMPOSITES

Substrate*	Test Number	Duration to Failure		Total Exposure, hrs.
		Test Temperature °C	Time to Failure, hrs.	
Ta	64-30-61	1850	No failure	15.60
Ta	64-30-65	1850	51	61
Nb	64-30-80	1800	No failure	15.75
Nb	64-30-83	1800	36	70
Mo	64-30-72	1800-1850	No failure	62
Mo	64-30-75	1850	76	200
W	64-30-79	1850	No failure	15.25
W	64-30-81	1850	No failure	117

* The iridium coating on all substrate metals was five mils thick

The loss of iridium was controlled by two factors: (1) the rate of oxidation and (2) the rate of interaction with the substrate metals. An average recession rate of 0.02 mil of iridium per hour, due to oxidation, was calculated from weight loss measurements. The life of an iridium-coated specimen was therefore greater for those substrate metals (e. g., molybdenum and tungsten) that reacted slowly with iridium, and the total life was shorter for the Ir-Nb system (in which the rate of interdiffusion

seemed to be the highest). The W-Ir specimen did not fail after being oxidized for 117 hours. In addition, metallographic examination of a cross section of the specimen did not reveal any internal oxidation.

One pressure-bonded composite of each of the metal substrates was oxidized at elevated temperatures and the test was terminated prior to failure. The results of these tests (Table II) indicate that the iridium loss by diffusion proceeds at a greater rate than does the iridium lost by volatile oxide formations. The observed diffusion rates of .065 mil/hour for W, .082 mil/hour for Ta, and .166 mil/hour for Nb correspond to the duration-to-failure specimens in which the Ir-Nb specimen failed after 36 hours, the Ir-Ta specimen failed after 51 hours, and the Ir-W specimen showed no signs of failure after 117 hours. As expected from reported permeability studies, no internal oxidation of the substrate metals or the reaction zones was evident in any of the composites.

Since the growth of the reaction zones in all of the systems studied are diffusion controlled, the data obtained from the oxidation tests cannot be used to predict the life expectancy of an iridium coating. An investigation of the parabolic growth rates in each system would yield the additional data needed to predict the coating life expectancy.

4. Oxygen-Methane Torch Tests

The oxygen-methane torch was used to thermally cycle pressure-bonded specimens in an oxidizing atmosphere. Each cycle consisted of heating the specimen rapidly to the test temperature, maintaining that temperature to within $\pm 15^\circ$ for five minutes, and then air cooling the specimen to room temperature. The arrest temperatures for the cycles to which Ir-Mo and Ir-W specimens were subjected were 1100°, 1400°, 1700°, and 1900°C. For the Ir-Nb specimen, the maximum temperature was 1800°C. For the Ir-Ta system, the arrest temperatures were around 1460°, 1550°, 1795°, and 1870°C. The specimens were examined with the unaided eye after each cycle. There were no apparent signs of failure.

E. Mechanical Behavior of Iridium

Iridium exhibits a high degree of work hardening, a behavior which is unusual for a metal having a face-centered cubic structure. The latest study on the deformation characteristics of iridium by Hieber, Mordike, and Haasen⁽⁷⁾ suggests that very small amounts of impurities segregated at the grain boundaries are the cause of the unusual work hardening behavior. Unfortunately, the impurities causing the embrittlement are not known and seem to be very much lower than those usually required to produce grain boundary weakness. In a similar investigation of the deformation characteristics of rhodium, Calverley and Rhys⁽⁸⁾ also concluded that grain boundary segregation of unknown impurities was the cause of embrittlement.

The unusual brittle behavior of iridium was also observed during this investigation. However, of greater significance was the observation that many of the iridium coatings that were electrodeposited on copper were as ductile as would be expected of face-centered cubic metals. Quite often, an iridium-coated copper sheet could be folded repeatedly by hand along the same line without the formation of cracks. Iridium electrodeposited on tantalum and niobium, however, was not ductile. Microbend tests of these latter composites produced cracks at a bend angle of less than 10 degrees, the cracks propagating along the grain boundaries. On the other hand, iridium roll-bonded with tantalum or niobium was bent to an angle greater than 90 degrees with no observable cracks forming.

A comparison was made between roll-bonded and electroplated iridium by means of X-ray diffraction and X-ray fluorescence analyses. The X-ray diffraction patterns of iridium electroplated on tantalum showed a random orientation of the crystallites, whereas the X-ray diffraction patterns of iridium roll bonded to tantalum showed preferred orientation. Both X-ray diffraction patterns and X-ray fluorescent patterns of the roll-bonded specimens showed the presence of aluminum. Although the preferred orientation of the iridium was expected, the presence of aluminum metal was not. In the roll-bonding operation, aluminum oxide powder was used as a barrier to prevent bonding between the specimen and the metal can. Apparently, the aluminum oxide was reduced to aluminum, which may have diffused into the iridium.

Sheet iridium is fabricated in a manner similar to the treatment used for roll bonding (exclusive of the canning operation needed to protect the substrate metals from oxidizing). Although iridium which was roll bonded to tantalum and niobium was bent to an angle greater than 90 degrees in the microbend tester with no observable cracks forming, at a bend angle of less than 10 degrees, cracks developed in a 0.020-inch thick piece of as-received iridium. The cracks propagated along the grain boundaries as shown in Figure 15, a photomicrograph taken at a magnification of 250 X. Efforts were made to enhance the plastic behavior of sheet iridium by heat treating small pieces ($\frac{1}{8}$ -inch by 1-inch) of 0.020-inch thick and 0.040-inch thick specimens in the following manner: Two specimens of 0.020-inch thick iridium were held at 1400°C for ten minutes under a pressure of about 5×10^{-6} torr. One of the specimens was quenched into a silicon oil bath and the other slowly cooled to room temperature. Both samples were bent to 33 degrees before microscopic examination revealed cracks; subsequently, they were bent through angles greater than 90 degrees without complete destruction. Evidently, quenching did not eliminate grain boundary cracking, and the increased plasticity resulted from strain relief, grain growth, or recrystallization and grain growth. Specimens cut from a 0.040-inch thick sheet of iridium were given the following heat treatments: (1) one specimen was held for two hours and another for 6.5 hours at between 970° and 1000°C, under vacuum, and slowly cooled, (2) one specimen was held for 1.5 hours and another for 72 hours at 970°C while encapsulated in a quartz tube containing powdered alumina, and (3) one specimen was held for two hours and a second for 64 hours between 600° and 630°C while encapsulated in a quartz tube containing powdered aluminum. All of the 0.040-inch thick specimens, except the one encapsulated with aluminum powder and heated for 64 hours, started cracking on the sides of maximum tension at bend angles less than ten degrees. Slip lines were evident during deformation, especially on the compression sides of the specimens; these slip lines terminated at the grain boundaries. The specimen heated for a prolonged period surrounded by aluminum powder reacted with the aluminum. When the sample was bent, cracks first appeared at an angle of about 37 degrees.

In this case, the cracks did not seem to start on the side of maximum tension but, rather, inside of what appeared to be a reaction zone. At approximately 44 degrees, a large crack propagated halfway through the specimen and fractured the reaction zone.

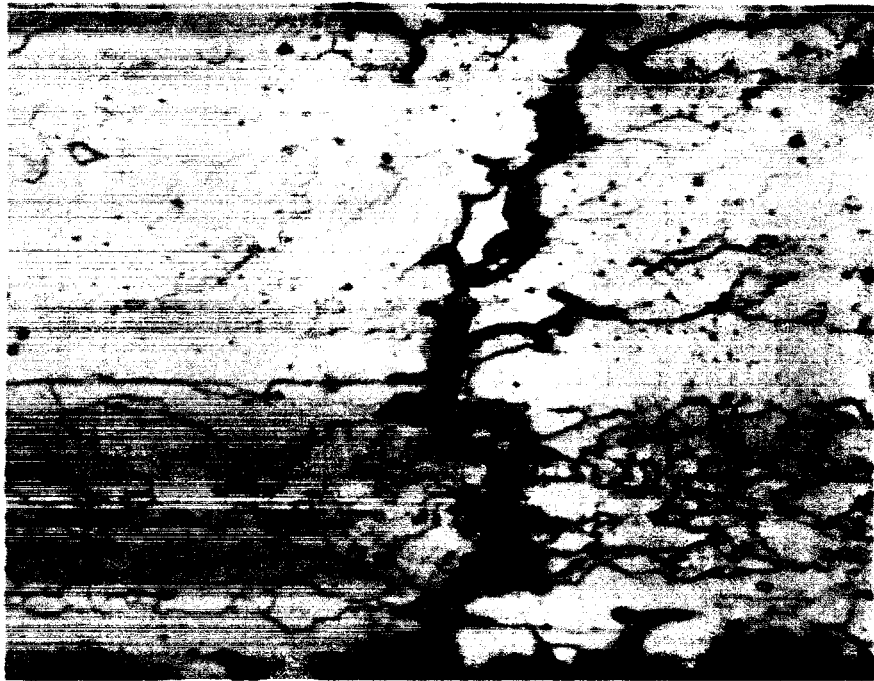

Figure 15. Photomicrograph of an Iridium Strip Bent to less than 10 Degrees.
250 X Magnification

N-7420

Neg. No. 1404-1

Although the above experiments are not sufficient for a detailed analysis of the mechanical behavior characteristic of iridium, they nevertheless substantiate the grain boundary weakness discovered by other investigators.^(7,8) Iridium can be plastically deformed at elevated temperatures. Cracks that appear upon deformation at room temperature and propagate along grain boundaries are usually indicative of an impurity that

is soluble in the metal at elevated temperature but precipitates out and agglomerates at the grain boundaries upon cooling to room temperature. The meager evidence accumulated in this and other investigations emphasizes the need for a research program designed to determine the effect of specific impurities on the deformation characteristics of iridium. A clear understanding of the deformation characteristics of iridium would be of interest both from the practical and theoretical standpoint.

VI. FUTURE PLANS

A proposal was submitted for the extension of this contract, Contract NASw-1030, for one year. This proposal outlines the basis for our recommendation that a systematic effort be made to determine:

- (1) a suitable method of applying the iridium coating and
- (2) a more detailed study of the rate of interdiffusion of the coating and substrates for the Ir-Mo, Ir-W, and Ir-Nb systems.

Evidence indicates that the major obstacle towards obtaining, consistently, adherent and coherent iridium coatings by electrochemical means stems from a gradual build-up of impurities in the electrolyte to a critical level. To overcome these difficulties, a new cell was constructed that will prevent atmospheric contamination of the electrolyte.

The interaction of iridium with the substrate metals niobium, molybdenum, and tungsten may affect the deformation characteristics of the composite materials. In addition, the life of an iridium coating during oxidation is controlled by two factors: (1) the rate of oxidation, and (2) the rate of interaction with the substrate metals. The former has been adequately investigated; the latter has received some attention under the present NASw-1030 program, in which the rate of interdiffusion of tantalum and iridium was investigated as a function of temperature. To fully predict the life of an iridium coating in contact with niobium, molybdenum, or tungsten, one must study the rate of growth of the diffusion zone between iridium and these metals.

REFERENCES

1. Withers, J.C., and Ritt, P.E., Proc. Am. Electroplaters Soc., pp. 124-129, June 17-20, 1957.
2. Mellors, G.W., and Senderoff, S., Electrochem. Soc. Abstract No. 89, October 1963.
3. Flinn, R.A., and Trojan, P.K., Metals Progress, July 1955.
4. Sedgwick, Chemical Elements and their Compounds, Oxford Press, 1950.
5. Kleinberg, J., Unfamiliar Oxidation States, University of Kansas Press, 1950.
6. Rapperport, E.J., Smith, M.F., Wulff, J., Brophy, J., Grant, N.J., Giessen, B.C., Taylor, A., and Doyle, N., "Refractory Metal Constitution Diagrams, Part II" TR CO-132, Wright-Patterson Air Force Base, Ohio, September 1962.
7. Hieber, H., Mordike, B.L., and Haasen, P. Platinum Metals Review 8, 102-106 (July 1964).
8. Calverley, A., and Rhys, D.W., Nature 183, 599 (1959).

DISTRIBUTION

NASA Headquarters (15)
Code RRM
Washington, D. C. 20546

NASA Headquarters
Code RRM
Washington, D. C. 20546
Attn.: Mr. Joseph Maltz

Attn: NASA Representative (2)
Scientific and Technology Information Facility
P. O. Box 5700
Bethesda, Maryland

Inspector of Naval Materials
Ferguson Building
1793 East 11 Street
Cleveland, Ohio 44114

**SAMPLE
PREPARATION**
T₀-Ir W-Ir
Cb-Ir Mo-Ir

