

NATIONAL BUREAU OF STANDARDS REPORT

9338

MOBIDIC - TELETYPE INTERFACE

GPO PRICE \$ _____

CFSTI PRICE(S) \$ _____

by

Hard copy (HC) \$2.00

Microfiche (MF) 150

Orrington R. Hall

653 July 65

Center for Computer Sciences and Technology

Institute for Applied Technology

N66 31377

FACILITY FORM 602

(ACCESSION NUMBER)	(THRU)
<u>37</u>	<u>1</u>
(PAGES)	(CODE)
<u>CR-76349</u>	<u>08</u>
(NASA CR OR TMX OR AD NUMBER)	(CATEGORY)



U.S. DEPARTMENT OF COMMERCE
NATIONAL BUREAU OF STANDARDS

THE NATIONAL BUREAU OF STANDARDS

The National Bureau of Standards is a principal focal point in the Federal Government for assuring maximum application of the physical and engineering sciences to the advancement of technology in industry and commerce. Its responsibilities include development and maintenance of the national standards of measurement, and the provisions of means for making measurements consistent with those standards; determination of physical constants and properties of materials; development of methods for testing materials, mechanisms, and structures, and making such tests as may be necessary, particularly for government agencies; cooperation in the establishment of standard practices for incorporation in codes and specifications; advisory service to government agencies on scientific and technical problems; invention and development of devices to serve special needs of the Government; assistance to industry, business, and consumers in the development and acceptance of commercial standards and simplified trade practice recommendations; administration of programs in cooperation with United States business groups and standards organizations for the development of international standards of practice; and maintenance of a clearinghouse for the collection and dissemination of scientific, technical, and engineering information. The scope of the Bureau's activities is suggested in the following listing of its three Institutes and their organizational units.

Institute for Basic Standards. Applied Mathematics. Electricity. Metrology. Mechanics. Heat. Atomic Physics. Physical Chemistry. Laboratory Astrophysics.* Radiation Physics. Radio Standards Laboratory.* Radio Standards Physics. Radio Standards Engineering. Office of Standard Reference Data.

Institute for Materials Research. Analytical Chemistry. Polymers. Metallurgy. Inorganic Materials. Reactor Radiations. Cryogenics.* Materials Evaluation Laboratory. Office of Standard Reference Materials.

Institute for Applied Technology. Building Research. Information Technology. Performance Test Development. Electronic Instrumentation. Textile and Apparel Technology Center. Technical Analysis. Office of Weights and Measures. Office of Engineering Standards. Office of Invention and Innovation. Office of Technical Resources. Clearinghouse for Federal Scientific and Technical Information.**

* Located at Boulder, Colorado, 80301.

** Located at 5285 Port Royal Road, Springfield, Virginia, 22171.

NATIONAL BUREAU OF STANDARDS REPORT

NBS PROJECT

4236427

NBS REPORT

9338

April 1966

MOBIDIC - TELETYPE INTERFACE

by

Orrington R. Hall

Center for Computer Sciences and Technology

Institute for Applied Technology

IMPORTANT NOTICE

NATIONAL BUREAU OF STANDARDS REPORTS are usually preliminary or progress accounting documents intended for use within the Government. Before material in the reports is formally published it is subjected to additional evaluation and review. For this reason, the publication, reprinting, reproduction, or open-literature listing of this Report, either in whole or in part, is not authorized unless permission is obtained in writing from the Office of the Director, National Bureau of Standards, Washington 25, D.C. Such permission is not needed, however, by the Government agency for which the Report has been specifically prepared if that agency wishes to reproduce additional copies for its own use.



U. S. DEPARTMENT OF COMMERCE
NATIONAL BUREAU OF STANDARDS

CONTENTS

	Page
I. INTRODUCTION	1
II. DESCRIPTION OF TELETYPE	1
III. DESCRIPTION OF MOBIDIC I/O	2
IV. DESCRIPTION OF INTERFACE	5
V. CONCLUSIONS	12
ACKNOWLEDGMENTS	12

LIST OF FIGURES

1. Over-all Block Diagram of MOBIDIC System
2. Partial Block Diagram of I/O Converter
3. MOBIDIC-Teletype Interface Block Diagram
4. Teletype Character Buffer (BF1) and Control Logic
5. Control Logic
6. BF2 and Associated Transfer Gates
7. DSU --- BF2 XFER Logic
8. "Read" Timing Diagram
9. "Write" Timing Diagram
10. Indicators

ABSTRACT

This document is a detailed engineering report concerning a device which is specifically designed to furnish a logic and electrical interface between the MODIDIC B twin digital computer and a standard eight-level code teletypewriter.

Among the features embodied in the unit are facility for handling a full "ASCII" character and a means of checking the character most recently transmitted to the teletype. This latter feature, which will be referred to hereafter in this report as an "echo" check, may be implemented in either a full-duplex or half-duplex system.

In either mode of operation, random manual depression of a teletype key while that teletype is receiving information will result in a disparity between the character transmitted and the character remaining in the interface at the end of transmission. Upon detection of such a disparity, an appropriate response may be obtained from the system. This feature affords the operator at the remote teletype the ability to communicate with the system during a long system-to-remote-station-transmission and thus has considerable utility.

Two of these units have been operating on a full-time basis since the second week of August 1965. Details of their operation have been recorded in the system engineering log, and substantial useful information has been derived therefrom.

MOBIDIC - TELETYPE INTERFACE

by

Orrington R. Hall

I. INTRODUCTION

The MOBIDIC-Teletype Interface is a device designed to enable two-way (half-duplex) communication between a teletypewriter and the MOBIDIC "B" twin digital computer. Data are received from the teletype in serial form with eight information bits per character. One MOBIDIC word of 36 bits is used for each teletype character.

Philosophy

All teletypes are serviced one character at a time. In this manner the MOBIDIC can service several teletypes simultaneously, taking in or printing out several different messages.

During input operations the teletype interface initiates an interrupt to the computer whenever a teletype character is received.

During output operations the computer transfers a character to the interface and proceeds to other programs. The interface initiates an interrupt as soon as the transmission of the character to the teletype is completed.

II. DESCRIPTION OF TELETYPE

The teletype described here is a standard Series 33 ASR machine. However, this discussion is applicable, in essence, to other models.

The American Standard Code for Information Interchange (ASCII) used by the teletype is a seven bit code with an eighth bit for parity sent or received serially. A binary "ONE" is represented by the presence of a predetermined direct current in the signal line to another teletype or related terminal device. In teletype terminology,

this condition is known as "marking". Conversely, a binary "ZERO" is represented by an absence of current in this signal line, and this condition is known as "spacing".

The eight intelligence elements in this code are preceded in time by a "Start" element (spacing) and are followed by two "STOP" elements (marking), thus giving eleven time elements, in all, per character. The standby state of the signal line, therefore, is "marking". All elements are approximately 9.09 milliseconds in duration, giving 100 milliseconds per character or 10 characters per second.

a) In full-duplex operation, a character transmitted by the computer to the printing unit of the teletype is simultaneously transmitted back to the interface by the teletype. The character thus received by the interface may then be compared with the character just transmitted by the computer.

b) In half-duplex operation, since simultaneous bi-directional information transfer is not possible, a simulated "echo" check is used. The character being transmitted to the remote teletype is simultaneously "ended around" in an interface buffer. At the end of transmission, the character in the buffer may be compared with the character just transmitted by the computer.

III. DESCRIPTION OF MOBIDIC I/O

A. General Philosophy

Figure 2* shows a block diagram of the I/O set-up and typical data and control paths between the I/O and a bilateral peripheral device. The I/O Converter has its own instruction register which contains, among other things, the address of the peripheral device selected for an I/O operation. Each such device has at least one Device Switching Unit (DSU) which has an address decoder set-up for a unique device address. (This address may be altered, if desired, by altering the arrangement of a set of toggle switches provided for this purpose). As the MOBIDIC I/O was originally conceived, there is one DSU per I/O Converter per I/O device. The DSU, in summary, performs the following functions:

1. Decodes the device address sent from the I/O Converter.

*All Figures appear in consecutive order in back of the text.

2. Routes appropriate control information between the I/O Converter and the selected device.
3. Transfers data between the I/O Converter and the selected device.

B. I/O Converter

The I/O Converter serves to effect a logic interface between the central processor and its associated peripheral devices. It has its own instruction register, which stores the current I/O instruction until it has been carried out, thus allowing the processor to attend to other matters during the I/O operation.

The MOBIDIC I/O system is organized in terms of 6-bit data characters, in order to accommodate the Field-data code. The I/O converter is designed to convert back and forth between 36-bit MOBIDIC words and 6-bit data characters.

During an input operation, data characters with six information bits are shifted in parallel through a succession of four buffers (Fig. 2) into the least significant six bit positions in the converter's Word Buffer Register (BFR). As each character reaches the BFR it is shifted six bit positions to the left in order to make room for the next character. This process is repeated until the BFR is filled with six characters, at which time a memory access is initiated. If a "STOP CODE" is detected at the first of the four character buffers (TAR), no further data is accepted from the input device. The Stop Code and remaining characters are propagated into the BFR and shifted left, with zeros being entered into any unused character positions. A memory access is then initiated and the input operation terminated.

During an output operation, the machine word to be transferred to the peripheral device is first sent from memory to the BFR. The six most significant bits are transferred in parallel through the four character buffers while the remaining contents of the BFR are shifted serially six bit positions to the left. This process is repeated each time a six bit character is sent to the selected output device from the last character buffer (TAR) until the number of words specified in the I/O instruction have been sent.

Operation of I/O With Regard to Teletype

As the MOBIDIC system is presently set up, only one I/O Converter is accessible to teletypes; therefore, only one DSU is necessary for each such device.

When a teletype key is pressed, an eight-bit ASCII character (seven bits plus parity) from the teletype is sent to the interface.

The eight-bit character is reorganized in the Interface into two six-bit characters to fit the required MOBIDIC I/O character configuration. For clarity, we may number these characters one and two. Character one contains the six most significant bits of the eight-bit teletype character. Character two contains, in its two most significant bit positions, the two least significant bits of the eight bit character. The remaining four bits of the second six-bit character are irrelevant. However, since a character containing all zeros is unacceptable to the MOBIDIC I/O, a one is placed in the least significant bit position of the second character to preclude this.

Characters one and two along with a third character, containing a "STOP CODE", are presented sequentially, in parallel, to the MOBIDIC I/O. The "STOP CODE" is detected, interpreted as a terminal character, and the input operation terminated. Two data characters, the "STOP CODE" character (in most cases*) and three blank characters, thus make up an entire 36-bit machine word. For the present, it is considered convenient to utilize one complete machine word for every teletype character.

During an input operation, information is presented to the Converter eight bits in parallel (Fig. 1). Bits one thru six are data bits, and so enter memory. Bits seven and eight are the control and parity bits respectively for the six-bit character. They influence the I/O, but are not stored in memory. After a character from the teletype has been transferred to the converter, the Interface generates a "STOP CODE" character (octal 57 with a one in the control position). This causes the computer to take in a single teletype character and proceed to other programs.

*If the octal digit formed by the three most significant bits of the character preceding the "STOP CODE" has a value less than 2, the "STOP CODE" is not stored and the four least significant characters in memory are blank.

During an output operation, the 36-bit word from memory is presented, six bits at a time and from the most significant end, to the Converter output lines. The "STOP CODE" has no meaning in an output operation.

Since there is only one Teletype character per MOBIDIC word, each word represents a complete output operation. As the transmission of a character to the Teletype is completed an interrupt is produced so that the Echo Check may be performed and another character transmitted, if desired.

In an output operation, the two six-bit characters containing the teletype character are sent back to the Interface, where the original eight-bit character is reassembled and serially transmitted back to the teletype. An "end around" capability is designed into the Interface so that at the end of the transmission, the character just transmitted remains in an Interface buffer accessible to the MOBIDIC I/O. The machine, depending upon the "software", may examine the Interface many times during the 100 msec. serial transmission to the teletype.

Each such examination will result in the detection of the "STOP CODE" (thus freeing the I/O until such time as the transmission is completed, whereupon the machine will detect the character transmitted. This "Echo Check" may be quite useful in sensing errors in or the end of transmission to the teletype).

IV. DESCRIPTION OF THE INTERFACE

A. General Description

An eight-bit ASCII character is reassembled, by the MOBIDIC-Teletype Interface into two six-bit characters. Character 1 contains the six most significant bits of the ASCII characters, while character 2 contains the remaining two, plus four irrelevant bits. One MOBIDIC word contains one ASCII character.

The Interface, during the appropriate input instruction (Read One Word into Specified Cell of Memory), serially shifts the eight-bit ASCII character from the teletype into BF1 (Fig. 4). Immediately after the shifting action is completed, the central processor is signaled that a teletype character is in the interface and the character is transferred in parallel to BF2. The central processor initiates a

"READ" operation, which causes the interface to start strobing data through the DSU into the TAR from BF2. At the first strobe, bits three thru eight are transferred to the TAR, and bits one and two are transferred from bit positions one and two of BF2 to positions seven and eight respectively. A "ONE" is set into bit three of BF2 and bits four, five, and six are zeroed. The second strobe then transfers the second six-bit character to the TAR. A third strobe transfers the "STOP CODE" into the TAR and the operation is halted.

For an output operation (write one word from specified cell of memory) a "WRITE" instruction is first sent to the DSU by the central processor. The DSU signals the interface, which then starts strobing data from the TAR. The first strobe transfers the first six-bit character into the six most significant bit positions of BF2. The second strobe transfers the two most significant bits of the second six-bit character into bit positions one and two of BF2. The other four bits of this second character plus characters three thru six (comprising the remainder of the MOBIDIC word) are strobed out of the converter, but are not used. The entire eight-bit ASCII character is sent to BF1, the "Write" operation is terminated, and a serial transfer of BF1 to the teletype is initiated. As BF1 is being shifted, the data are "ended around" so that at the end of the teletype cycle, the character just transferred is again in BF1. The central processor is signaled, BF1 is shifted back to BF2, and the processor may check the character.

B. Detailed Discussion of Interface Operation

1. Read one word into a selected memory address.

Figure 4 shows the serializing buffer (BF1) and associated control circuitry. The 560 ohm resistor in the collector circuit of the 2N404 transistor (upper center of the drawing) in conjunction with the -12V collector supply comprises the 20ma current source to the teletype signal line. The teletype, when transmitting data, furnishes only contact openings and closures. The normal state of the signal line is "marking", which means that the teletype contacts are closed, and the transistor is turned on, thus ensuring closed circuit and a 20ma direct current in the line. The combination of the Zener diode and the 200ua current source at the base of Power Driver C11-10 gives the input circuit 6V of noise immunity. In addition, the 560 ohm current source resistor and the 0.5 μ fd capacitor just forward of the Zener diode form a filter circuit which ensures that no noise spike, whatever the magnitude of its voltage, will be seen by the input unless

its duration exceeds 200 μ sec. Power drivers C11-10, C14-15, and C4-6 serve to restore the signal to a rate of rise in excess of $6V/\mu$ sec.

One-shots A5 and A6 form a pulse generator, the repetition rate of which exactly corresponds to that of the teletype at 110 bits/sec. Flip-flops A9-16, A10-4, and A10-16 comprise an eight bit counter which controls the pulse generator, so that eight pulses are generated for each ASCII character.

When a teletype key is depressed, current in the line is initially interrupted for a period of 9.09 msec. (Start Element). The line voltage swings, consequently, from ground potential to between eight and twelve volts negative. This voltage excursion triggers One-shot A7, the period of which matches the 9.09 msec start element. The trailing edge of A7 sets Control Flip-flop A9-9, which releases the clamps on the time element counter, inhibits the "SET" input of One-shot A7, and starts the pulse generator. This initiates a series of eight shift pulses which have a one-to-one correspondence, timewise, with the eight elements of the ASCII character. After the character has been serially shifted into BF1, the time element counter overflows, thus resetting the Control Flip-flop, which:

- a. Clamps the counter.
- b. Stops the pulse generator.
- c. Sets Flip-flop C6-9 (Fig. 5).

If a "Read" operation is not already in progress, C6-9 triggers One-shot All, which sends an "Interrupt" signal to the processor, releases the "STOP CODE", clamps in BF2, and generates a "Character 1 to Buffer 2" (Ch1-BF2) (R) transfer signal. The trailing edge of All resets C6-9. If a "Read" operation is already in progress, C6-9 does not trigger All, but allows the next "Read" operation to do so.

(Ch1-BF2) (R), on its trailing edge, performs the following:

- a. Sets the Character Flip-flop B5-9 to the Ch 2 state.
- b. Transfers the character from BF1 to BF2.

There are two control lines from the DSU to the interface. One, "DSU ON", goes negative whenever the DSU in question is selected by the

I/O converter, and maintains the level (-4V) until the end of the operation. The other, which we shall call the "Write" line, initially goes negative for either a "Read" or "Write" operation. However, in the former case the "Write" line returns to ground 18 μ sec later, thus hitting trigger gate B4-4 (Fig. 5) which has been previously armed by One-shot B3. This action sets "Read" Flip-flop B2-9, which performs the following:

- a. Starts the Strobe Generator (C9 and C10).
- b. Completes the arming of "AND" gate B13, thus allowing the 1st strobe pulse to generate a Character 2 to Buffer 2 transfer (Ch2 \rightarrow BF2) (R).
- c. Initiates (Ch1 \rightarrow BF2) (R) and the computer interrupt signal if Pulse Gate C7-11 has previously been armed by Flip-flop C6-9. This was discussed earlier. As may be seen from Fig. 5, the Strobe Generator furnishes two signals to the I/O Converter. "Data Enable" places the appropriate information on the input lines. After approximately 1.5 usec delay due to the inherent propagation time of Inverters A2-7 and A2-9, the Strobe Pulse strobos the information into the Converter. Thus the first Strobe enters the first six-bit character into the Converter while generating (Ch2 \rightarrow BF2) (R) which performs the following:
 - (1) Transfers the two least significant bits of the ASCII character in BF2 to the two most significant bit positions in BF2 (Fig. 6).
 - (2) Places a "one" in bit position 3 of BF2 and zeros bits 4, 5, and 6. It will be remembered that these bits have a one-to-one correspondence with bits 1, 2, 3, and 4 of the six-bit MO BIDIC character. Bits 1, 2, 3, and 4 of the second MO BIDIC character are irrelevant since the remaining bits of the ASCII character are in bits 5 and 6, but a "one" is placed in bit 1 to prevent the TAR from being presented with a "zero" character, which is prohibited.

- (3) Resets the character flip-flop to the Ch1 state. The second strobe pulse strobes the second character into the TAR and clamps the Stop Code back into BF2. The third strobes the Stop Code into the TAR. Three "zero" characters are then entered by the Converter into the BFR in order to fill it, a memory access is initiated and the "DSU ON" signal is turned off by the Converter, thus stopping the Strobe Generator and resetting the "Read" flip-flop.

In the event of a "Read" operation from the computer when there is no ASCII character in BF2, Stop Code is strobed into the TAR.

2. Write one word from a selected memory address.

Initiation of an I/O operation is sensed at the interface, as before, by the lowering of the "DSU ON" and "Write" lines from the DSU. However, it will be remembered that the identity of the operation cannot be ascertained until 18 μ sec later, when the "Write" line will return to ground, as in the "Read" operation, or remain at -4V, as in the "Write" operation. In a previous paragraph, it was shown that the return of the "Write" line initiated the appropriate function in the Interface for an input operation. For an output operation, One-shot B3 (Fig. 5) waits the necessary time interval for the first character to be transferred to the TAR, then strobes the "Write" line. The "Write" flip-flop is thus set, and performs the following:

- a. Releases the Stop Code clamps in BF2.
- b. Ensures that the Character flip-flop is in the Ch1 state.
- c. Arms Pulse Gate C7-16.
- d. Triggers the Strobe Pulse Generator.

"Data Enable" is put on the appropriate control line as before, but has no function in an output operation. The first Strobe transfers the contents of the TAR onto the output lines, then generates (Ch1-BF2) (W), which transfers the first six-bit character from the

output lines into the six most significant bit positions of BF2. The Character flip-flop is also set to the Ch2 state at this time. In like manner, the second strobe transfers the two most significant bits of the TAR into the two least significant bit positions of BF2. The four least significant bits of this second character from the TAR are discarded. The entire ASCII character is now assembled in BF2. The consequent resetting of the Character Flip-flop by (Ch2→BF2) (W) sets Flip-flop C6-21, which inhibits strobes to Power Drivers C4-17 and C4-15. C6-21 also arms "AND" gate C3-24 to permit the third pulse from the Strobe Generator to generate BF2→BF1. BF2→BF1 performs the following:

- a. Transfers the contents of BF2 to BF1.
- b. Clamps the Stop Code back into BF2.
- c. Sets the Xmit/Rcv-flip-flop in the Xmit state (Fig. 4).

In this state, the Xmit/Rcv flip-flop performs the following:

- a. Inhibits further generation of BF2→BF1.
- b. Initiates a serial shift of the contents of BF1 to the teletype.
- c. Allows the leading edge of the Shift Pulse Generator signal to generate the BF1 shift pulses.
- d. Arms the BF1 "end around" shift.

While this is being done, the four remaining MOBIDIC characters are strobed out of the TAR, thrown away, and the I/O operation terminated. The Xmit/Rcv flip-flop A3-9 initiates the shift of the contents of BF1 to the teletype by performing two functions:

- a. It turns off the line breaking transistor in the upper center portion of Fig. 4, thus interrupting current in the line and initiating a receiving sequence in the teletype.

V. CONCLUSIONS

In light of the experience we have gained from six months of full-time operation of the system, the following conclusions have been reached regarding the performance of the interface and its relation to the system:

1. The one-shots in the particular series of packages used have proved quite temperature sensitive. Minimization of unreliability stemming from this condition would necessitate use of a less temperature sensitive series of packages or restriction of ambient temperature to a range not practicable in all environmental situations.

2. A full-duplex "echo check" seems to be feasible for short distances provided that the printing unit and the keyboard of the remote teletype are connected for this operation. This should afford a full check of the I/O, the transmission line, and the remote terminal equipment, and will be more thoroughly investigated in the very near future.

3. The present half-duplex simulated "echo check" which "ends around" the transmitted character within the interface, is working quite satisfactorily. Although the transmission line and the remote terminal are not checked, the "interrupt" capability by the remote terminal is fully as effective as it would be in full-duplex operation.

ACKNOWLEDGMENTS

The author would like to express his indebtedness to the following members of the Computer Technology Section for their contributions to this project: L. J. Boezi for his investigation of the MOBIDIC I/O characteristics and requirements; R. L. French and W. H. Basye for their attention to detail in the drafting and the physical construction and installation of the interfaces; D. E. Rippey for his suggested changes and modifications.

- b. It triggers One-shot A7, thus starting the train of eight shift pulses which exactly match the teletype sequence.

Information during each pulse period is determined by the state of the least significant stage of BF1. One-shot A8 is triggered only when Pulse Gate A4-23 is armed by a binary "one" in the least significant stage of BF1 (A18-21), and under this condition, a "One" in the form of 20ma of line current, will be transmitted to the teletype during the pulse period in question. The teletype distributor contacts remain closed while the teletype is receiving information.

During the teletype sequence, the computer, depending upon the organization of the software, may follow one of three procedures:

- a. It may "time out" a period equal to or in excess of the 110 msec. required for the teletype cycle, after which time it may initiate another output operation.
- b. It may perform successive "Read" operations. During the teletype cycle, the Stop Code will be detected by the computer with each "Read". At the end of the teletype cycle, which coincides with the conclusion of the BF1 "end around", the transmitted character, assuming no malfunction, will be read. At this time the computer may transmit another character, or in the event of malfunction, choose to retransmit the original character.
- c. It may attend to other matters until such time that it receives an "Interrupt" signal from the interface, signifying an end of transmission.

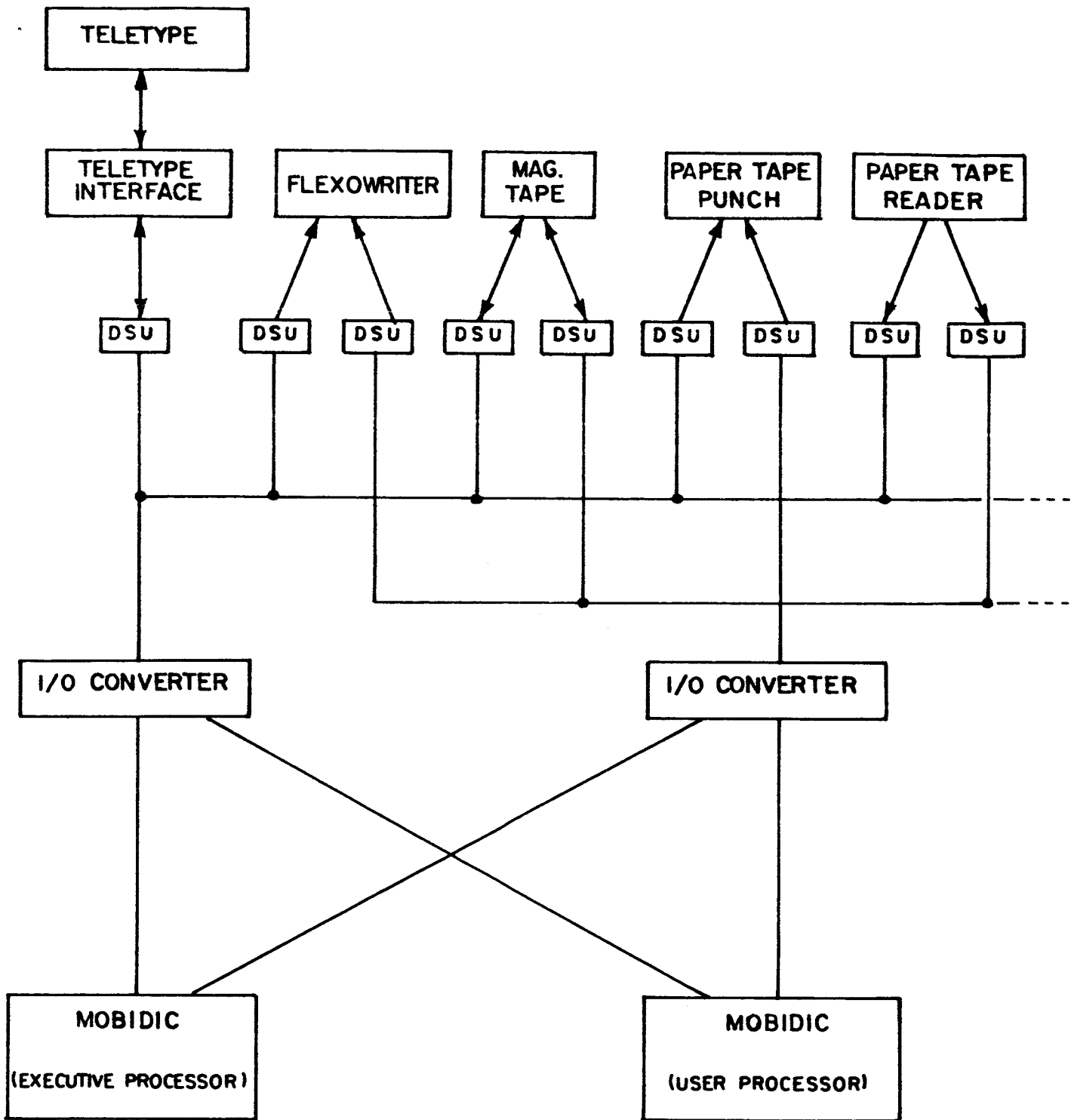

FIGURE 1. OVERALL BLOCK DIAGRAM OF MOBIDIC SYSTEM

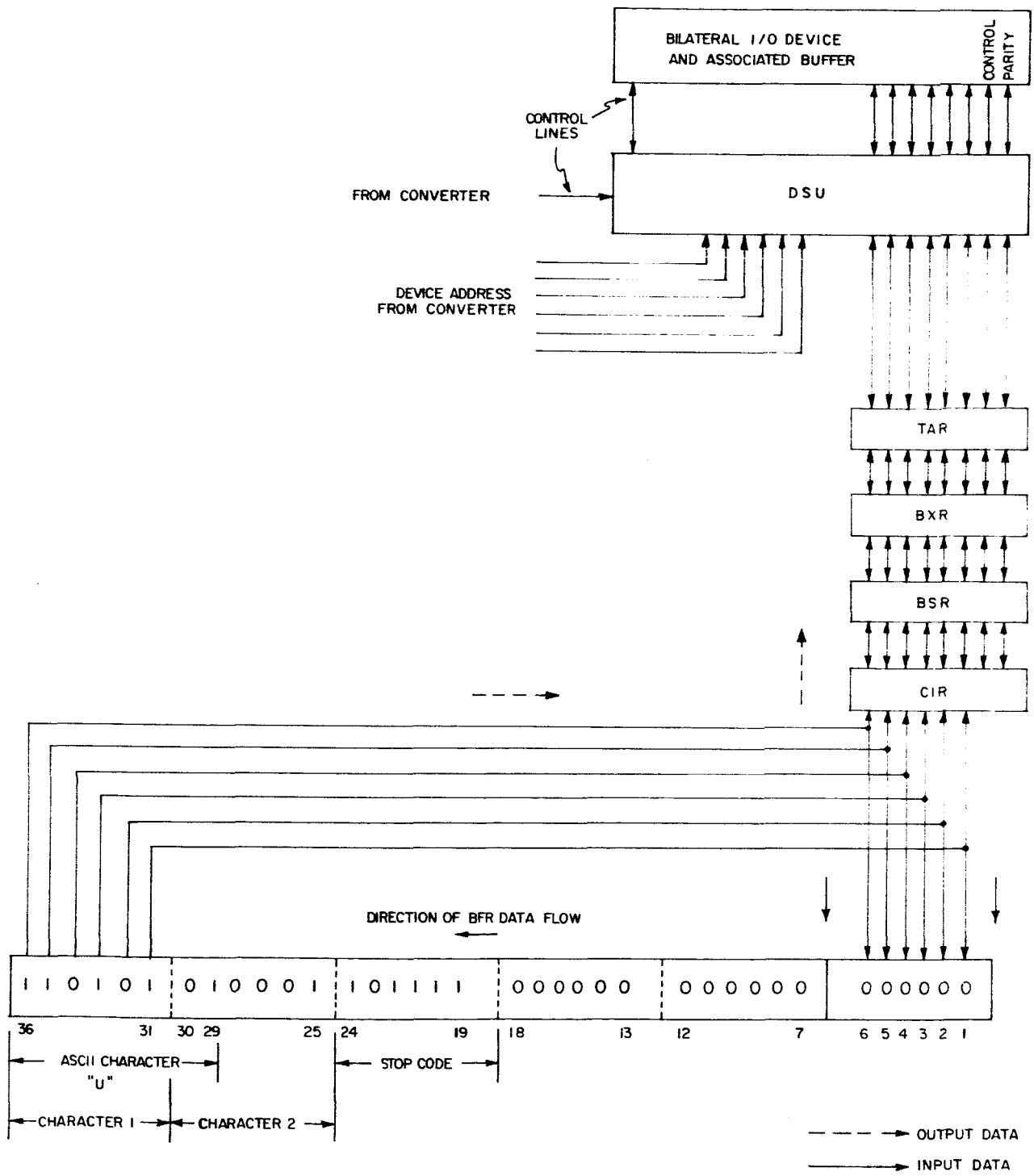

FIGURE 2. PARTIAL BLOCK DIAGRAM OF I/O CONVERTER

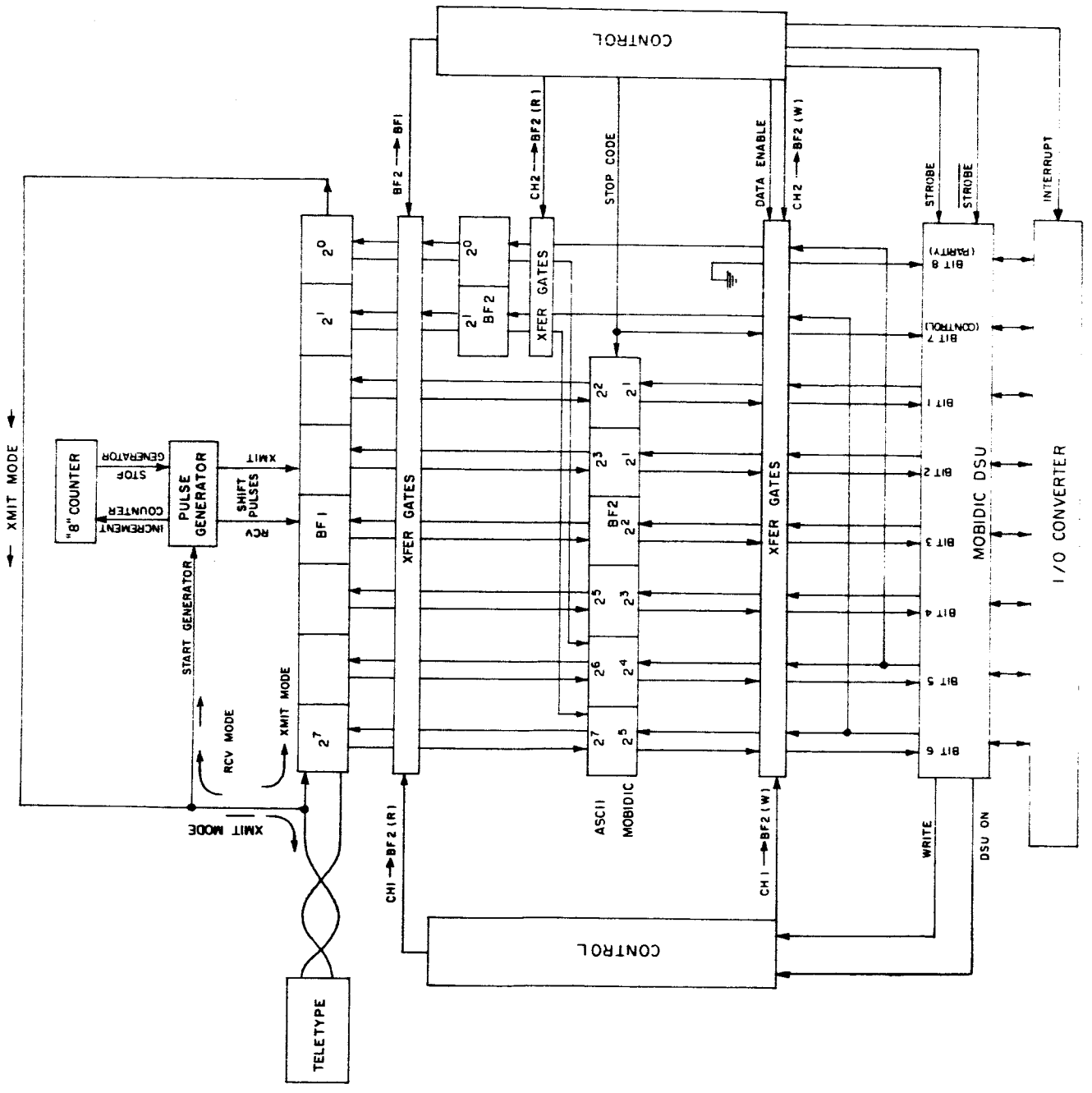
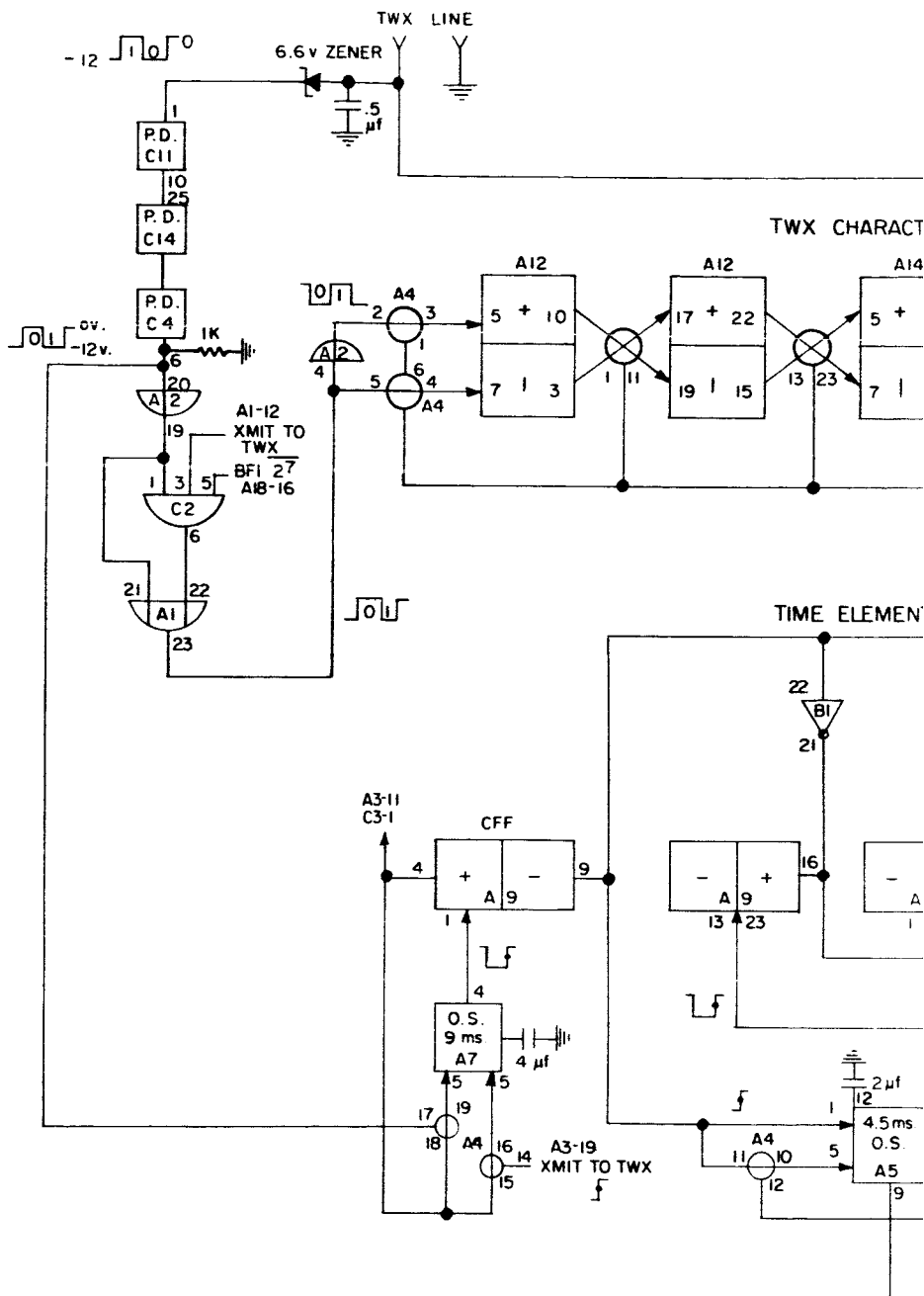
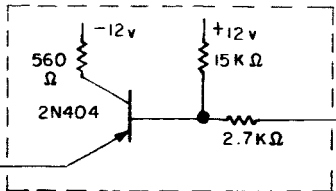

FIGURE 3. MOBIDIC-TELETYPE INTERFACE BLOCK DIAGRAM



4-1

FIGURE 4 TELETYPE CHARACTER BUS



ER BUFFER (BF1)

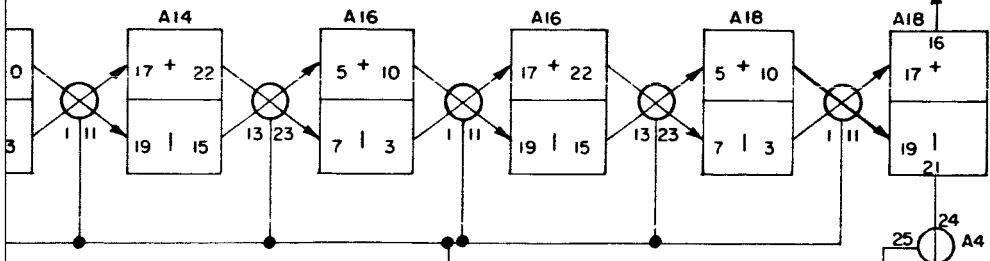

COUNTER

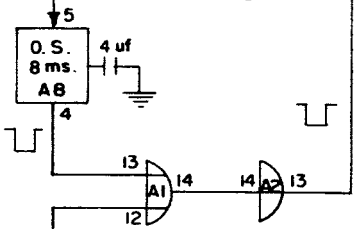
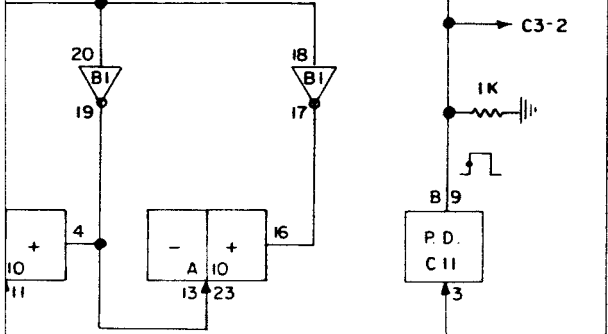

TO FF
RESET EMITTERS

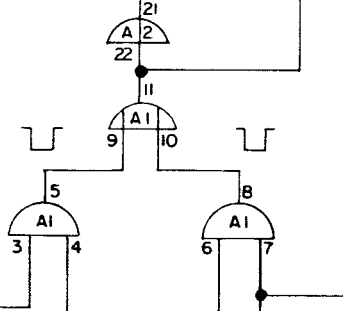
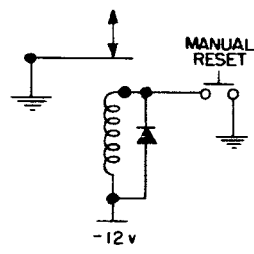

XMIT TO
TWX
A1-7, 12
A4-14
C2-3

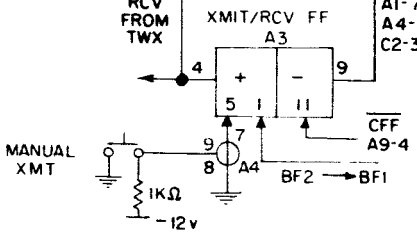

FER (BF1) AND CONTROL LOGIC

4-2

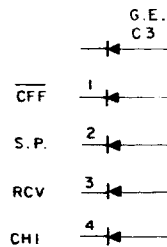
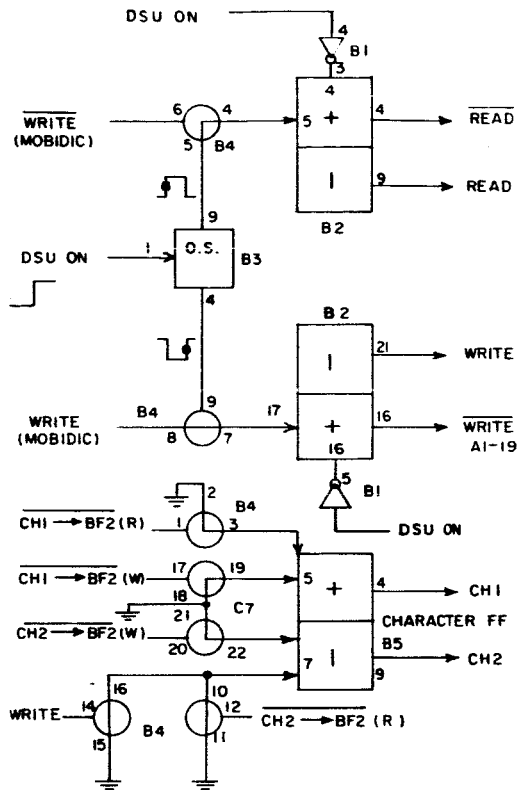

READ
RCV
CH 2
STROBE

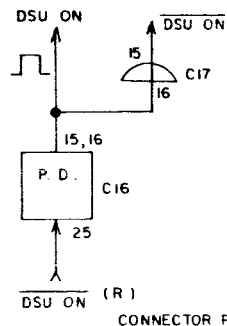
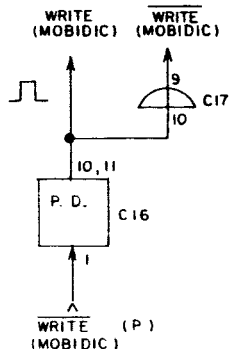
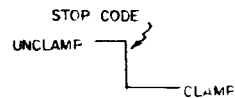
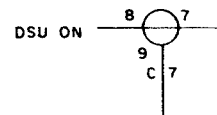
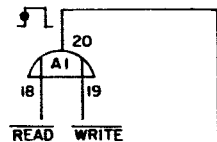
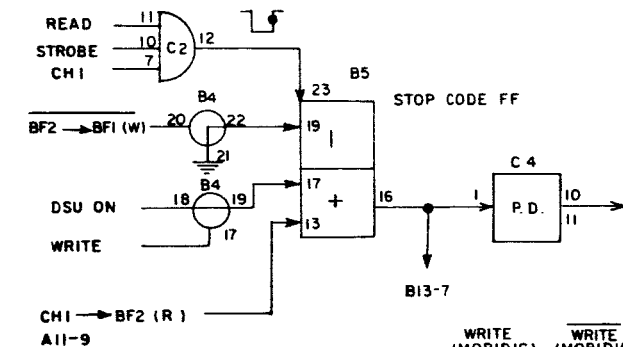

5-1

FIGURE 5. C

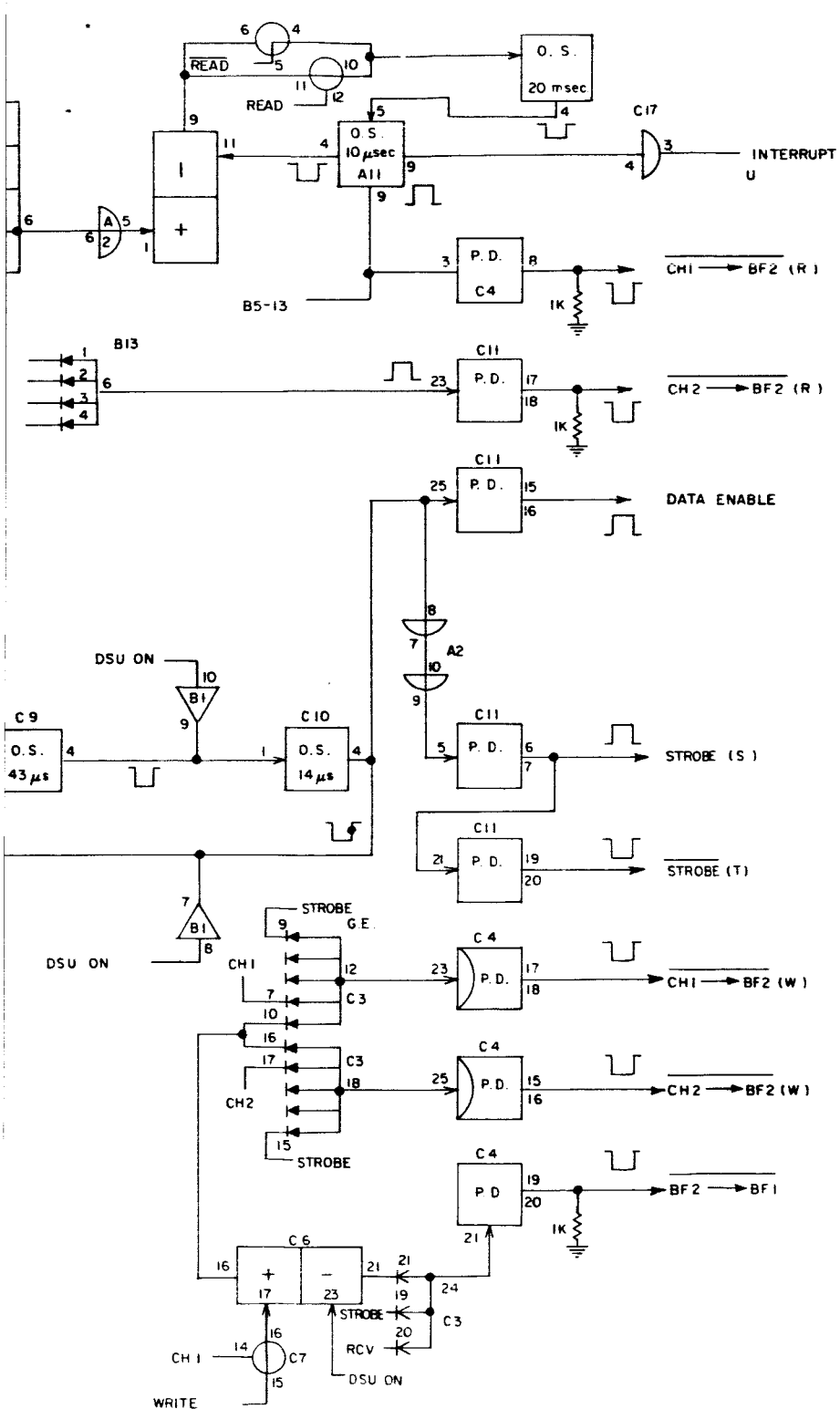

5-2

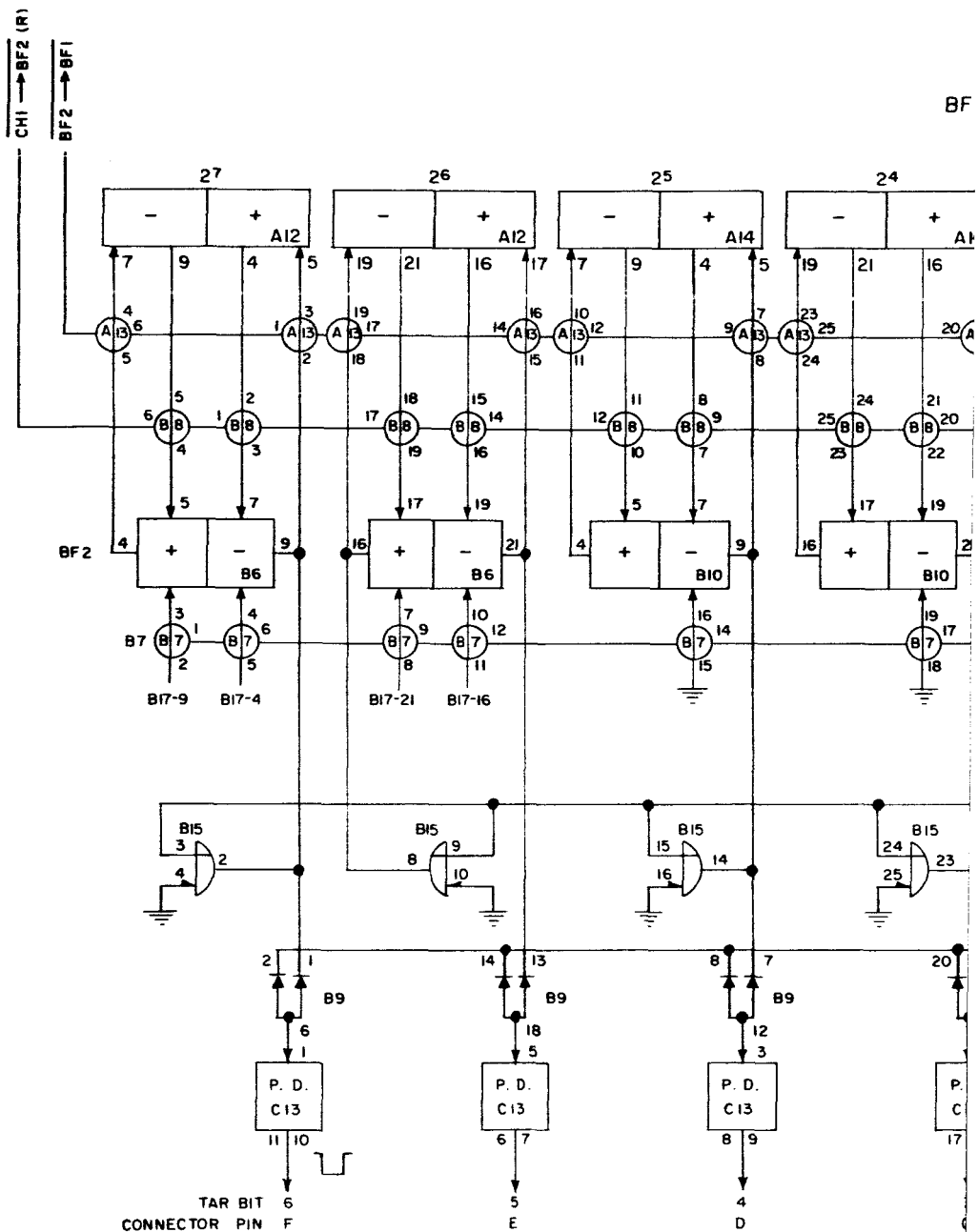

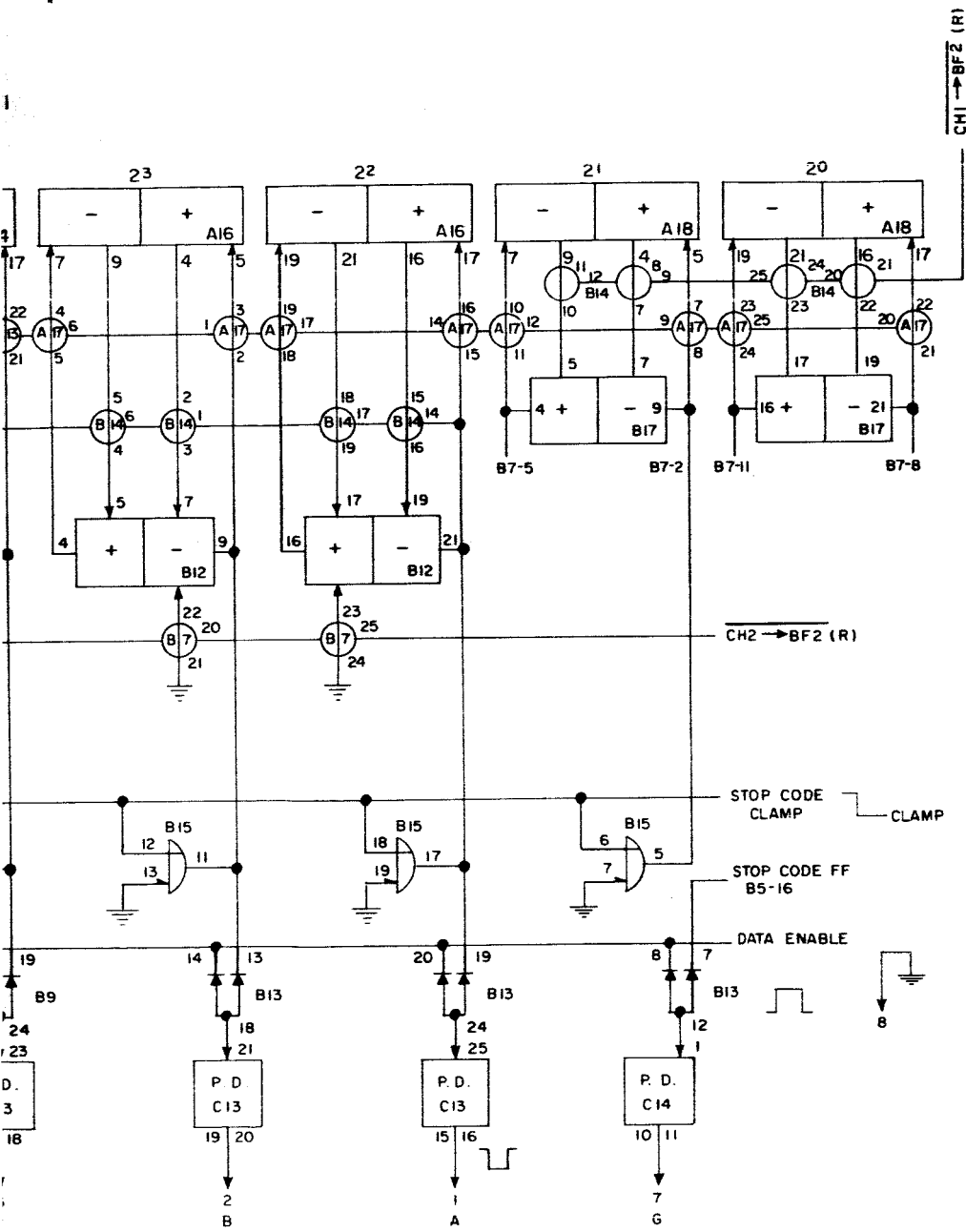

DSU

OCIATED TRANSFER GATES

6-2

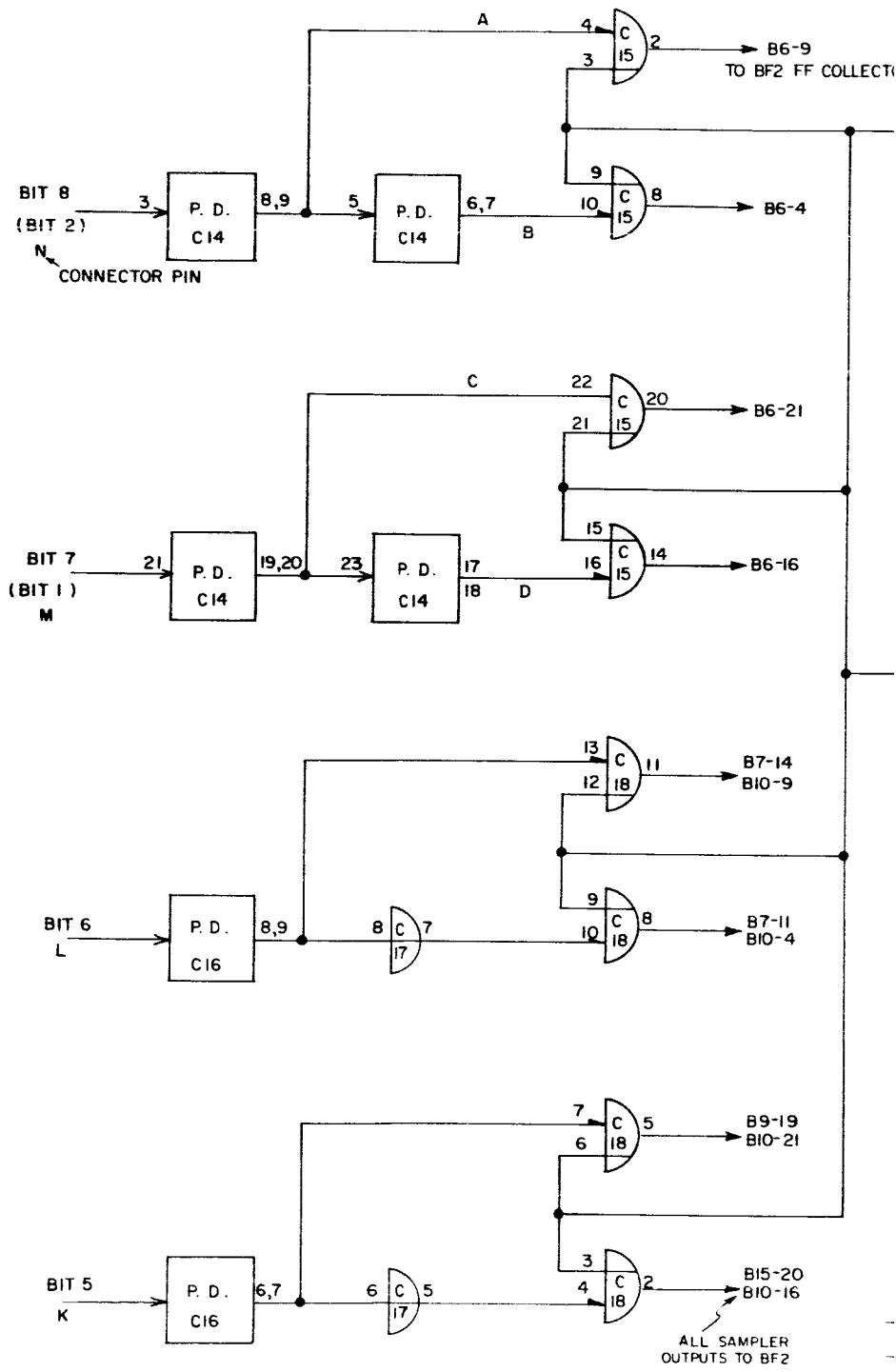

7-1

FIGURE 7. DSU → B

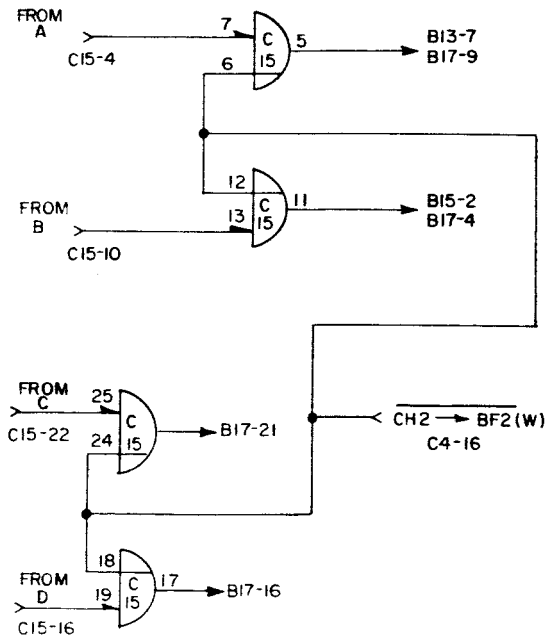
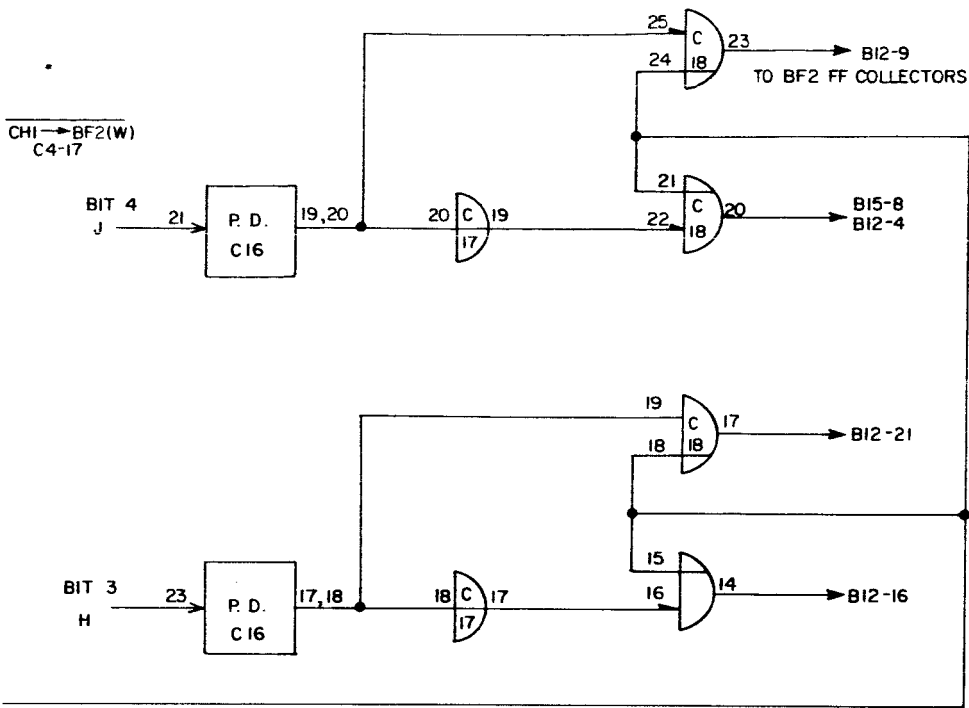

NOTE:
BIT NUMBERS ON THIS DWG. ARE
DESIGNATED IN REFERENCE TO ASCII CHAR'S.

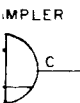

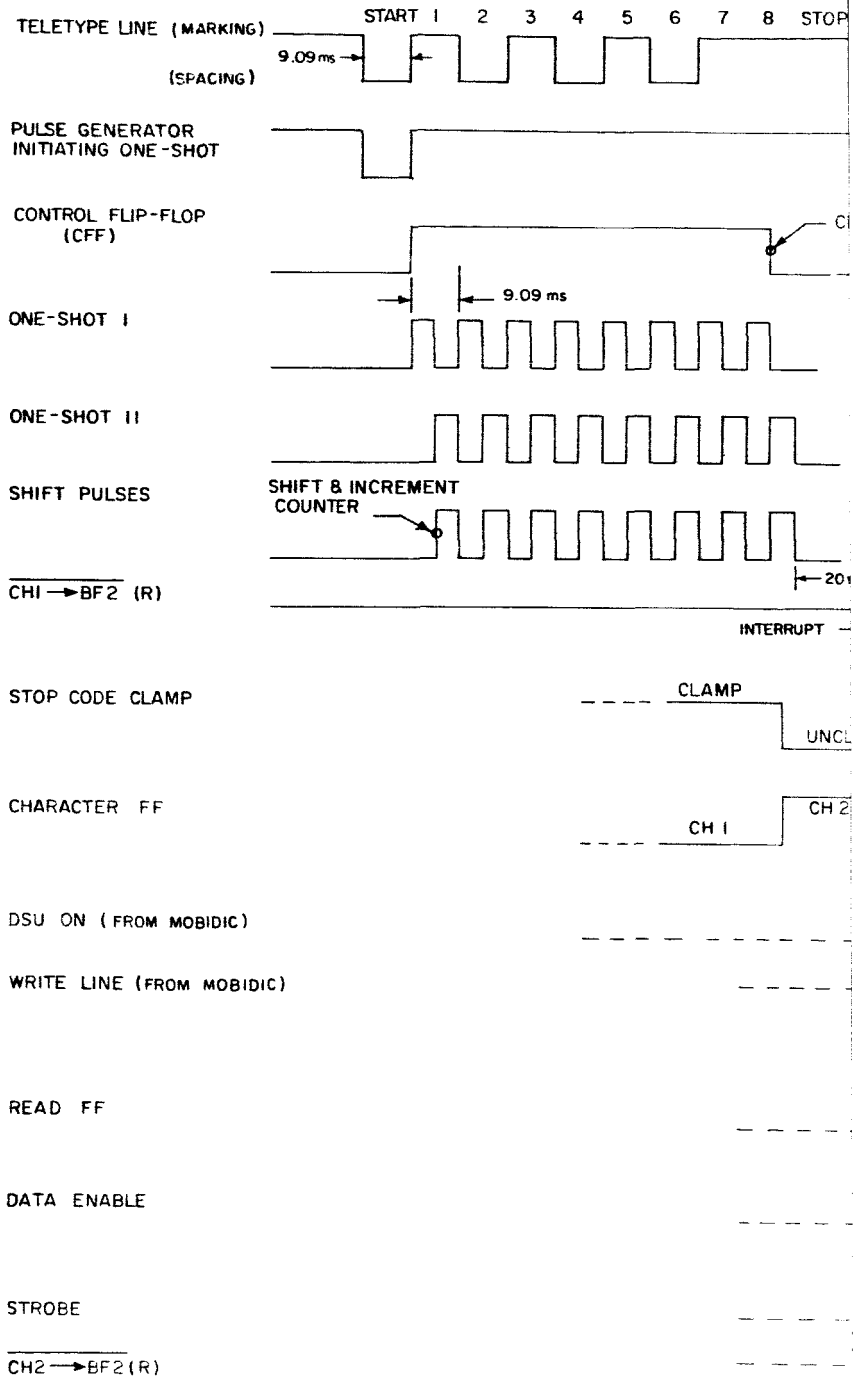

8-1

FIGURE 8. "R"

LETTER "U"

LAMP COUNTER

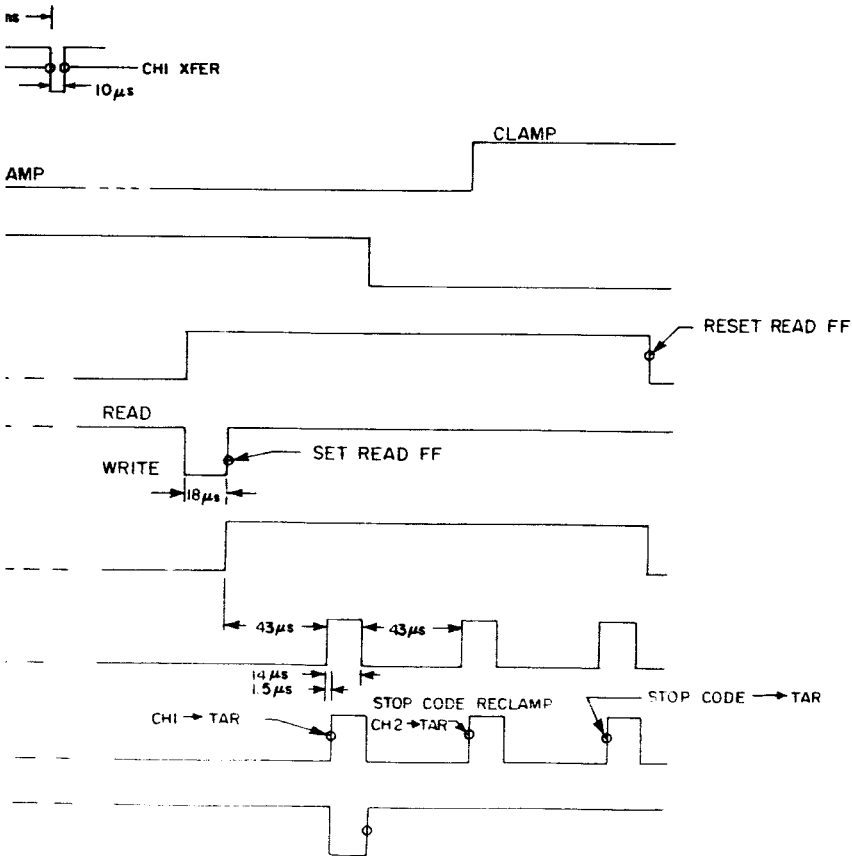

READ" TIMING DIAGRAM

8-2

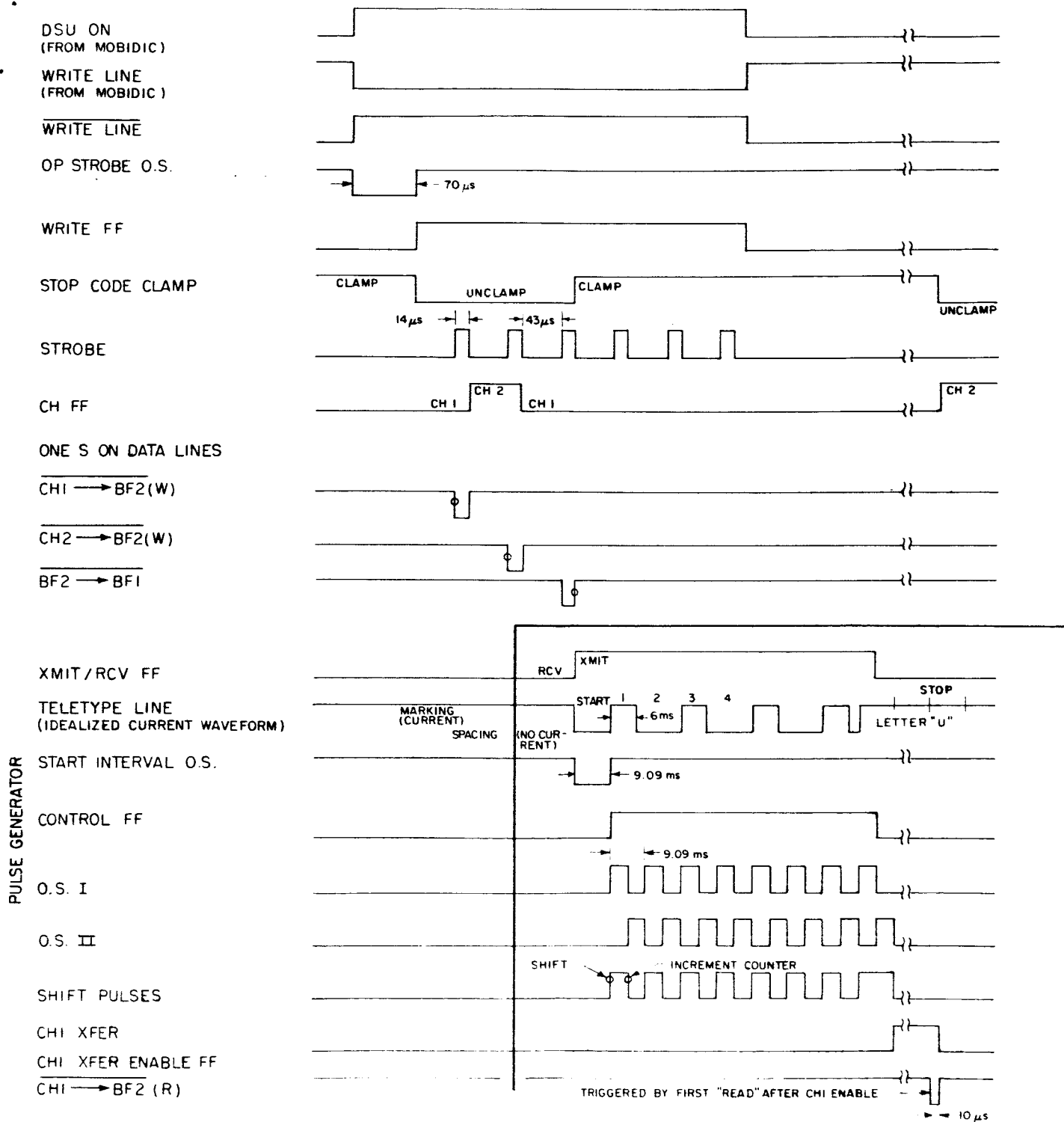

FIGURE 9. "WRITE" TIMING DIAGRAM

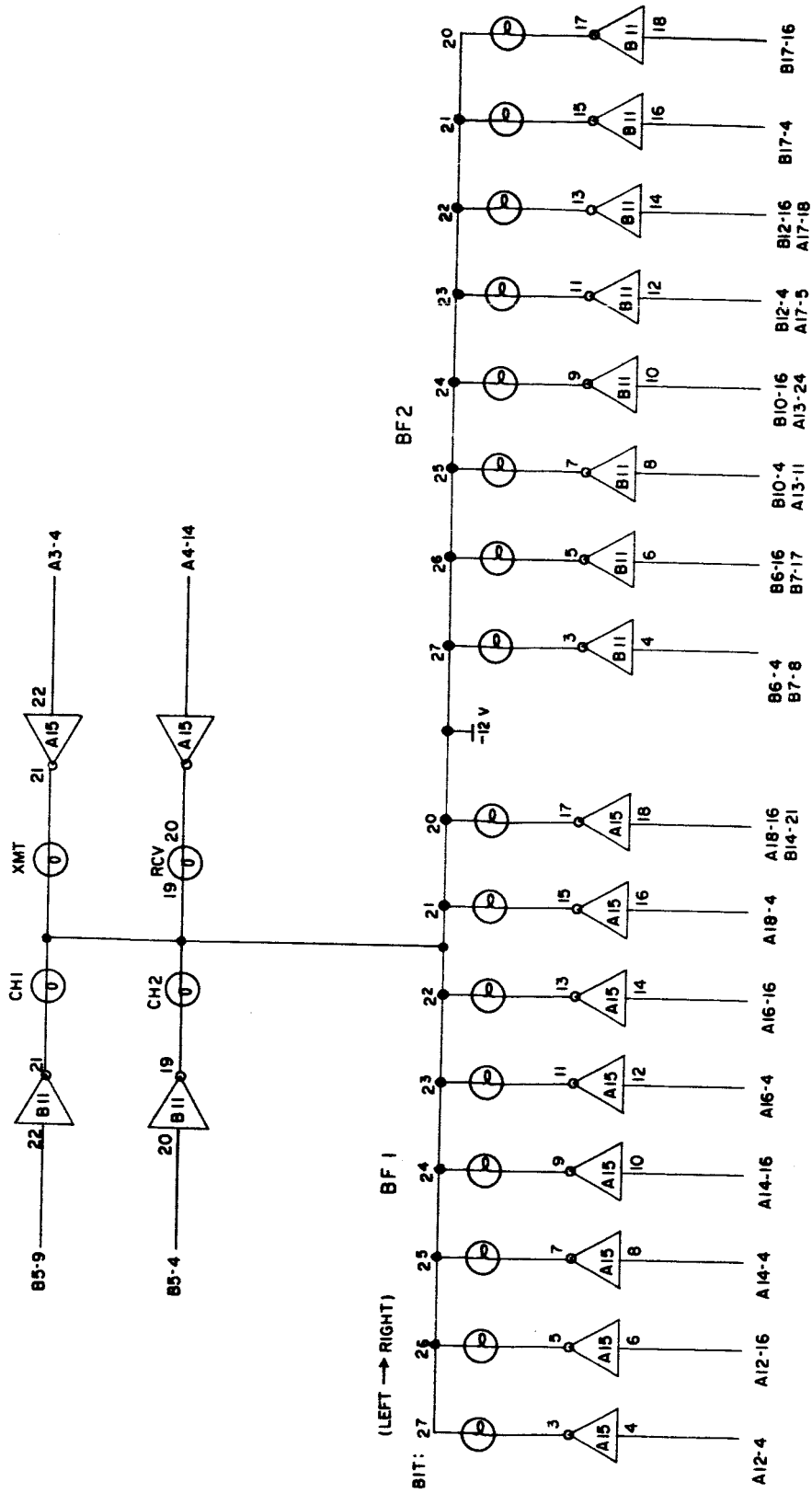

FIGURE 10. INDICATORS