

NASA Grant NGR-36-003-054

PART IV

CONSTRUCTION OF TORSIONAL PENDULUM
FOR CRYOGENIC TEMPERATURES

Worked Performed by
I. Kuriyama

Report Prepared by
Eric Baer and I. Kuriyama

ABSTRACT

A torsion pendulum is described which allows the measurement of relaxations in polymers down to 4°K.

DESCRIPTION OF THE APPARATUS

The torsion pendulum which was recently built to study the cryogenic properties of polymers down to liquid helium temperatures] is similar to instruments previously designed by Weinig [1] and Schwartz [2]. [It is enclosed in a vacuum system for low temperatures ranging from 4.2 to 300°K. The apparatus consists of a pendulum, an optical recording system for the oscillatory motion, and a cryostat chamber] shown schematically in Figs. 1 and 2.

The polymer specimen (3.5 in. long, 0.5 in. wide and approximately 0.005 in. thick) is clamped at its lower end to a brass flange forming the upper base of the liquid helium container J (capacity 1 liter). This flange has groove for fastening the lower specimen clamp and a few pin-holes for diffusion of evaporated helium gas. The helium container is supported from the mounting stage D by means of a thin wall stainless steel tube G and two concentric copper tubes I. The upper end of the specimen is connected by means of a thin stainless steel tube K to the inertia member C which in turn is supported by a fine steel wire B from the holder of a counterbalance which is set up on the mounting stage D. Consequently, the specimen is subjected to slight longitudinal stress during the measurements.

When assembled the specimen S and clamps are completely surrounded by the copper shield I. The specimen chamber and the liquid helium container J are enclosed by the inner glass Dewar container which is connected to the underside of the top base plate F by a vacuum-tight "O" ring gasket. An outer glass Dewar V surrounds the inner Dewar and rests on a wooden platform.

A 1000 ohm manganin resistance wire, which is between outer and inner copper shields I, is used to evaporate excess liquid helium at the start of

an experiment, and also serves to raise the temperature of the specimen chamber during the course of an experiment. The temperature of the specimen is measured by means of two copper-constantan thermocouples. One thermocouple is closed to the upper specimen clamp and the other is in the proximity of the lower clamp. Thermocouple voltages are measured with a Leeds and Northrup Type K-3 universal potentiometer.

The inertia member C consist of a copper bar with weights attached to its ends, two electromagnets screwed in the center of these weights, and a small mirror at the center of the pendulum arm. The mounting stage D is supported on the top base plate F by three spring dampers E. These components are surrounded by the brass bell jar O, which has a window for transmission of a light beam, a helium discharge tube, a vacuum gauge, several electrical leads and a connection for the vacuum pump (Fig. 2). All connections through the top base plate and bell jar are made with vacuum tight O-ring joints.

The optical system focuses on the sensing area of a photocell located just overhead the glass window on the inside wall of the bell jar about 5 ins. from the pendulum mirror. The torsional oscillation of the specimen was measured by the photocell voltage which is recorded on a sanborn Type 150 recorder. Sample oscillation is excited by means of two electromagnets previously described which are attached to the inertia weights.

EXPERIMENTAL PROCEDURE

First the specimen is mounted on the torsion pendulum. The inner Dewar and the upper side of the bell jar are then clamped in position, while the outer Dewar remains on its platform surrounding the inner Dewar. The apparatus is then evacuated and the outer Dewar is filled with liquid nitrogen which lowers

temperature in the specimen chamber to 150°K. The vacuum pump is stopped and the inner Dewar and bell jar are flashed with helium gas. Liquid helium is then transferred from a storage container to the inner Dewar, to lower the temperature from 150 to 4.2°K. When the helium transfer is finished, the end of the discharge tube is then sealed off. Some control over the warming rate may be obtained by keeping a small amount of liquid helium in the bottom of the inner Dewar. In this manner, the evaporating gas prevents the apparatus from warming up too rapidly. After the recording assembly has been placed into position and aligned, the excess liquid helium in the inner Dewar is evaporated using the heater. The warming rate and temperature fluctuations may be controlled by adjusting the current to the heater.

The pendulum can be excited at any chosen temperatures and the oscillations are recorded with the photocell arrangement. The modulus and the logarithmic decrement are obtained from the graphic records of the torsional oscillations. Data are taken one minute after oscillation is excited with the electromagnets, and a continuous record is then made for a period of 120 to 150 secs. In this manner (for the usual frequency of 1.32 cps at which the measurements are made), the logarithmic decrement can be computed over 20 to 30 oscillations.

Typical data which are currently being generated with the apparatus are shown in Figure 3. New cryogenic transitions (relaxation maxima) which have very recently been observed in PET will be described in detail in subsequent reports with special emphasis on the structural origin of these maxima. (The data confirm that a versatile torsion pendulum has been successfully built for cryogenic studies down to 4.2°K.)

SAMPLE PREPARATION

Before preparing the various samples, pellets of PET were first dried at 130°C in a vacuum oven for 24 hrs. Subsequently, the melt crystallized and quenched film samples were then made from these pellets using a standard press. The thickness was controlled by placing the polymer between a 6 x 6 inch brass frame of the desired thickness (1 or 5 mil.). Material was placed in the press between sheets of Teflon coated foil to facilitate sample removal and heated to 280°C. 40,000 lbs of press pressure was then slowly applied for about three minutes. The polymer was cooled in various ways. Quenched samples were prepared by removing molten polymer from the press at 280°C and dipping into ice water or dry-ice-acetone solution. Slow-cooled samples were made by lowering the temperature at a rate of 0.5°C/min. to 180°C under a slight pressure. After 180°C was reached, the heaters were turned off and the sample was gradually cooled to room temperature. In order to aid sample removal, a silicone compound (Dow Corning 11) was applied to the Teflon coated foil.

To insure dryness, the quenched amorphous sample was maintained in a vacuum at room temperature for 2 or 3 days to remove loosely held water. Also, amorphous samples are crystallized by heating at 110°C for 10 hrs in silicone oil or at 200°C for 30 min. in nitrogen. To avoid irregular surfaces which are easily produced during annealing, the sample was annealed between thin metal plates having good thermal conductivity.

FIGURE CAPTIONS

Figure I Schematic diagram of torsion pendulum apparatus.

A: Counterbalance
B: Steel suspension wire
C: Moment member
D: Mounting stage
E: Spring damper
F: Top base plate
G: Thin wall stainless steel tube
H: Heater
I: Cooper radiation shield
J: Liquid helium container
K: Stainless steel tube for suspension of specimen and its clamps.
M: Mirror
O: The underside of bell-jar
S: Film specimen
T: Thermocouples
U: Inner glass Dewar
V: Outer glass Dewar

Figure II External appearance of brass bell jar surrounding moment member.

Figure III Shear modulus, G' , and loss modulus, G'' , as a function of temperature for amorphous PET.

REFERENCES

1. S. Weinig, Rev. Sci. Inst. 26, 91 (1955).
2. J. C. Schwartz, Rev. Sci. Inst. 32, 335 (1961).

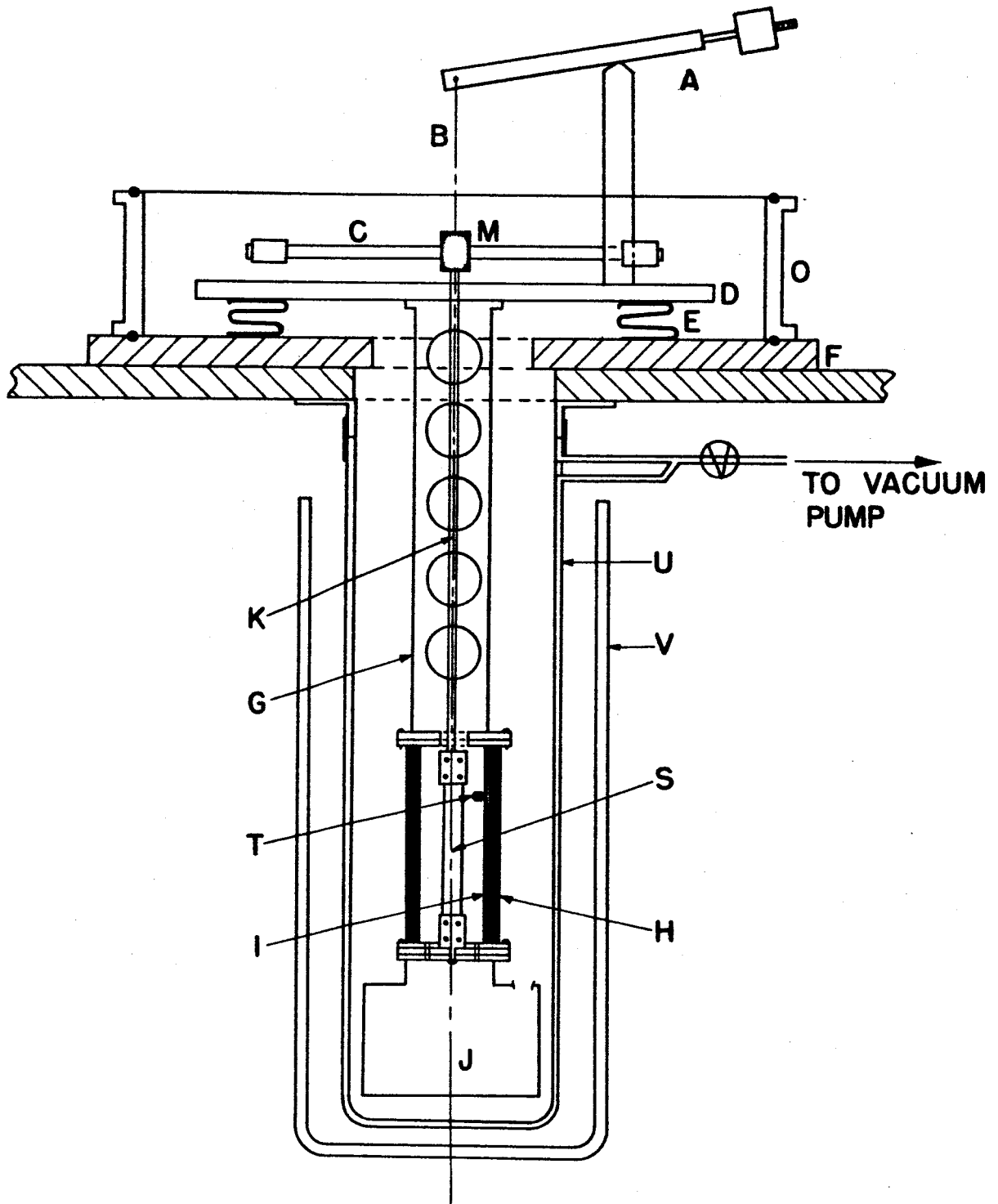

TEI
E
LE

