

NASA CONTRACTOR REPORT



NASA CR-560

0099479



TECH LIBRARY KAFB, NM

NASA CR-560

NOT LIBRARY; RETURN TO
ACTUAL (WALB 2)
KIRTLAND AFB, N MEX

EFFECTS OF TIME DELAY IN THE VISUAL FEEDBACK LOOP OF A MAN-MACHINE SYSTEM

by John McLean Leslie

Prepared by
STANFORD UNIVERSITY
Stanford, Calif.

for

NATIONAL AERONAUTICS AND SPACE ADMINISTRATION • WASHINGTON, D. C. • SEPTEMBER 1966



**EFFECTS OF TIME DELAY IN THE VISUAL FEEDBACK LOOP
OF A MAN-MACHINE SYSTEM**

By John McLean Leslie

Distribution of this report is provided in the interest of information exchange. Responsibility for the contents resides in the author or organization that prepared it.

Prepared under Grant No. Nsg 111-61 by
STANFORD UNIVERSITY
Stanford, Calif.

for

NATIONAL AERONAUTICS AND SPACE ADMINISTRATION

For sale by the Clearinghouse for Federal Scientific and Technical Information
Springfield, Virginia 22151 - Price \$3.00

FOREWORD

The work covered by this report "Effects of Time Delay in the Visual Feedback Loop of a Man-Machine System", by John M. Leslie, was part of the total research performed at Stanford University under Grant NSG 111-61.

The work was monitored by Mr. Wendell Chase of the Man-Machine Integration Branch at NASA/Ames Research Center.

This report was submitted to Stanford University in December 1965 as partial fulfillment of the requirement for the degree of Engineer.

ACKNOWLEDGEMENTS

The author is indebted to the many people who both listened and contributed to the theories brought forth by this study of visual time delay and its effects. He specially appreciates the velvet-gloved direction and stimulating encouragement of Professor David A. Thompson who supervised the effort.

The thesis received financial support from the National Aeronautics and Space Administration under Grant NSG 111-61.

ABSTRACT

This Thesis was aimed at studying the effects of time delay in the visual feedback loop of a man-machine system. A one-dimensional, step-type input, pursuit tracking experiment was developed to study these effects with transmission-type delays of zero to ten seconds. Thirty-six subjects participated in a series of tests that covered: seven different delays, two different levels of course complexity for each delay, learning, and open-loop conditions. It was found that tracking performance deteriorates non-linearly with increases in delay and that the magnitude of this performance degradation is a function of course complexity.

The system cutoff frequency (f_{co}) can be approximated by

$$f_{co} = \frac{0.14}{T^{0.7}} \text{ for all delays (T) which are much greater}$$

than the operator reaction time and for all course complexities studied. A quasi-linear model for system performance was developed.



TABLE OF CONTENTS

	<u>Page</u>
Acknowledgement	v
Abstract	vii
List of Illustrations	x
List of Tables	xii
Chapters	
I Introduction	1
A. Problem	
B. Objectives	
C. Background	
D. Highlights of Literature Search	
II Tests and Their Design	20
A. General	
B. Hypotheses to be Tested	
C. Approach to Experiments	
D. Equipment	
E. Test Procedures	
III Results of Tests	41
A. General	
B. Performance versus Delay (Phase 1)	
C. Effects of Course Complexity (Phase 2)	
D. Learning Behavior (Phase 3)	
E. Open-Loop Performance (Phase 4)	
IV Discussion of Results	56
A. General	
B. Development of a Model	
C. Comparison of Experiment and Model	
D. Comparison of Results to Hypotheses	
V Conclusions	74
A. General	
B. Design Considerations	
C. Suggestions for Future Work	
List of References	81
Appendix A	87
Appendix B	96

LIST OF ILLUSTRATIONS

<u>Figure</u>	<u>Page</u>
1 Pursuit-Tracking Block Diagram	4, 20
2 System Block Diagram	22
3 System Installation	23
4 Operator Control Unit	23
5 Rear-Operator Control Unit	32
6 Frequency Generators - Operator Control Unit . .	33
7 Frequency Sensing Circuits - Operator Control Unit	35
8 Phases 1 and 2 Tracking Performance: 0.00 Second Delay	44
9 Phases 1 and 2 Tracking Performance: 0.27 Second Delay	44
10 Phases 1 and 2 Tracking Performance: 0.50 Second Delay	45
11 Phases 1 and 2 Tracking Performance: 1.00 Second Delay	45
12 Phases 1 and 2 Tracking Performance: 2.60 Second Delay	46
13 Phases 1 and 2 Tracking Performance: 5.00 Second Delay	46
14 Phases 1 and 2 Tracking Performance: 10.00 Second Delay	47
15 Phase 1 Tracking Performance: Composite	47
16 Phase 2 Tracking Performance: 0.00 Second Program	51
17 Phase 2 Tracking Performance: 1.00 Second Program	51
18 Performance as a Function of Course Frequency and Delay (0.00, 0.27, 0.50, 1.00 Sec.)	53
19 Performance as a Function of Course Frequency and Delay (1.0, 2.6, 5.0 Sec.)	53
20 Performance Improvement: Repeated Tracking of 0.5 Second Program with 0.5 Second Delay	53
21 Open-Loop Performance: Repeated Tracking of 0.5 Second Program	53
22 Phases 1 and 2 Cutoff Frequency Versus Delay . .	57
23 Expanded Block Diagram: Pursuit-Tracking . . .	61

LIST OF ILLUSTRATIONS
(Continuous)

<u>Figure</u>		<u>Page</u>
24	Simplified Block Diagram	62
25	Quasi-Linear Mathematical Model Performance . . .	67
26	Phase 1 and Mathematical Model Cutoff Frequency Versus Delay	67
27	Zero-Second-Delay Performance: Model and Experiment	70

TABLES

<u>Table</u>		<u>Page</u>
1	Hypothesized Cutoff Periods and Frequencies . . .	24
2	Schedule of Light-Illumination Dwell Periods . .	25
3	Program Running Time	26
4	Program Schedule: Phases 1 and 2	28
5	Measured Cutoff Points: Phase 1	48
6	Program Comparison: Phases 1 and 2	50
7	Measured Cutoff Frequencies: Phases 1 and 2 . .	56
8	Program Comparison: 1.0 Second Delay	58
9	Best-Fit Values for Mathematical Model	65
10	Cutoff Frequency Comparison: Model and experiment	68

Chapter I

INTRODUCTION

A. Problem

Delay of feedback information can be a very frustrating experience to a person. Anyone who has had the misfortune of speaking in a highly reverberant auditorium has had the nerve-wracking difficulties of trying mentally to screen out his echo while he continues to speak. It is well known (Fairbanks^{26*}; Kalmus, Fry and Denes⁴⁰; Bergiejk and David¹³) that if the auditory delay is approximately 0.2 seconds, the speaker becomes confused, speaks haltingly, and becomes unable to avoid making errors in articulation. Auditory delays of this magnitude are easily obtainable: sound travels at approximately 1100 ft/sec., so 0.2 seconds delay is introduced by sound traveling from the speaker, to the rear wall of a 110 foot deep auditorium, and back to the speaker. Fortunately in most auditoriums, the reverberation is reduced to a sufficiently low level that the speaker does not become upset by the echo.

The apparent cause of speech degradation by delay, according to Fairbanks²⁶, is that the auditory feedback becomes a mixture of that which is delayed through the air with that which is not delayed; the latter being due to both proprioceptive and tactile feedback.

Experience with visual sensory feedback delay is not nearly as prevalent as with auditory. The reason is apparent when one considers that light travels at approximately 186,000 miles per second; or approximately 1000 feet per microsecond.

*Superscripts refer to List of References, Section VI.

Nonetheless even small visual delays cause degradation of operator performance. Conklin¹⁹ reported that tracking performance is impaired with the presence of relatively small transmission-type delays in a control system, and even when such delays are below the operator's threshold of perception. Bergeijk and David¹³ experimented with delayed visual feedback on a person's ability to write and found that his performance deteriorates monotonically with delays up to 520 milliseconds (which was the limit of their tests). Kalmus, Fry, and Denes⁴⁰ explained writing and drawing difficulties with visual delay as follows: "The proprioception from the hand indicates that the drawing of a feature has been completed, but the eyes and eye muscles contradict this". Smith, McCrary and Smith⁶⁴ reported that the effect of 520 millisecond visual delay, as revealed in their observations, is that, "performance becomes inordinately difficult and frustrating. It is nearly impossible to perform the simplest of tasks such as placing a dot in the center of a circle with any reasonable degree of accuracy".

Delay of Visual Feedback Causes Performance Degradation

There is ample proof, and it is intuitively obvious, that people are highly dependent upon feedback in their sensory/motor response operations. Furthermore, it has been well established^{13,19,26,40,64} that a person's performance suffers degradation when either auditory or visual feedback is delayed. Yet in the case of visual transmission-type delays (all elements of the visual information delayed an equal amount), there has been little research done to determine, quantitatively, the relation of delay, task complexity, and performance degradation.

There is a growing need for knowledge of this relationship to keep pace with desires for remote control of equipment on distant planets, spacecraft, and space platforms. Such man-machine systems can easily incorporate visual time delays of seconds to minutes. In the case of communications with the moon, the round-trip time for radio and television transmission is approximately 2.6 seconds --- and the moon is a close range objective in the United States' probe of outer space.

B. Objectives

This thesis will be directed to the study of the effects of time delay in the visual feedback loop of a man-machine system. The specific objectives are as follows:

1. Learn the character of an operator's pursuit tracking capability when subjected to a delay of visual observation of the results of his previous control commands; the studies and tests will be at delays of 0.00, 0.27, 0.50, 1.00, 2.60, 5.00 and 10.00 seconds.
2. Describe a mathematical relationship between operator performance and the magnitude of delay of visual feedback information.
3. Consider the implications of such delays upon the design of man-machine systems.

Concentration will be on pursuit tracking rather than compensatory. In pursuit tracking, the subject sees both the input signal and the "follower", and he controls the latter to track the former. At any given instant, he has the advantage of seeing the input, the output (the results of his control commands), and the difference between the two. In compensatory tracking, the subject is much more limited: he never directly sees the input or output; he observes only the difference between the two; his tracking

objective is to null-out (compensate) the difference signal.

A block diagram of the pursuit tracking system that will be studied is shown in Figure 1: both the input and the output are shown individually on a display; the operator (or subject) responds, as he sees fit, by suitable manipulation of his control; one delay period later he observes the result of this manipulation on the display, and then he repeats the cycle.

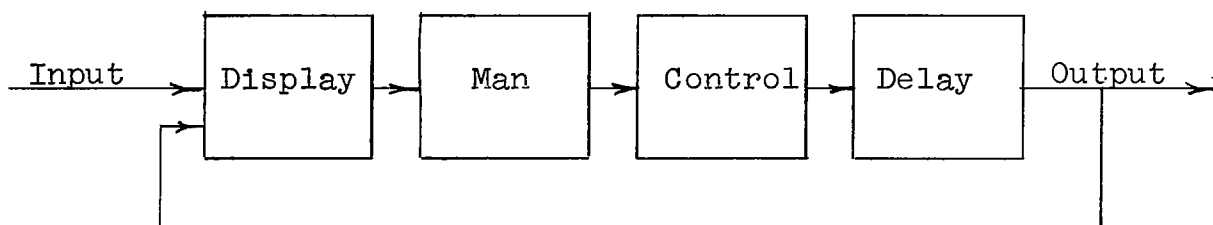

Figure 1

Pursuit-Tracking Block Diagram

C. Background

The earliest reported work regarding transmission-type visual delays was performed by Warwick⁷³ in 1949. He worked with compensatory (not pursuit) tracking and limited his work to delays of 0 to only 320 milliseconds. He concluded that any amount of transmission-type control lag (delay) affects tracking accuracy as measured by the time-on-target. He hypothesized that there is an inverse linear relationship between the logarithm of time-on-target and the control lag. His subjects tracked an input that was a combination of 0.1 and 0.5 cps; with 320 milliseconds delay, their tracking performance (time-on-target) dropped approximately 50% from the zero delay case.

Lunar Vehicle Tracking Studies

In 1961, Adams^{4,5,6} ran pursuit-tracking experiments with a crab-type (4 wheel steering) vehicle that was remotely controlled through a time delay. His results, for a vehicle speed of 2.7 feet per second, showed the time-on-target for his course to fall both rapidly and non-linearly from a value of 98% with no delay to a level of 25% with 2 seconds delay. He also found that the time-on-target became less as the course complexity became greater.

In 1962, Chomet, Freeberg, and Swanson¹⁷ reported on tests they had run, on a vehicle remotely controlled through a 3.0 second delay. The same year, Fox³² released his test results of a jeep driven with a delay of 2.5 seconds. Both studies showed that delay caused a degradation of tracking performance and that the magnitude of degradation was greatest for courses having the greatest complexity.

In 1963, Braisted^{8,16} reported on his work with a lunar vehicle predictor system. This system provided the driver with immediate feedback of the approximate location where the vehicle should be (on the lunar surface) one time delay period later.

In principle, the predictor does automatically what the driver would try to do if he did not have the advantage of a predictor, but the predictor is able to do it better. As an explanation, first consider a case having no predictor. The driver views the course to be tracked on a television monitor. He mentally must project himself and imagine he is driving a vehicle positioned 2.6 seconds ahead on the course if he is to steer with knowledge of the results of his steering commands; this is the minimum time required for his steering command to reach the moon and for feedback

information to be returned. The driver must compensate mentally for the effects of the 2.6 second delay. To do so, he must remember, and somehow integrate, all of his commands for any previous 2.6 second period in order to have a reasonable idea of the effect of his next command. The Braisted predictor handles the memory and integration aspects of this job for the driver.

With the predictor, the driver sees a small ellipse on his television screen which he can "steer" with his wheel. This ellipse is automatically positioned one delay period ahead on the road. It responds to a composite of all steering commands in any previous 2.6 second period. As a result the "bug" responds immediately to the driver's next command in a manner similar to the way the vehicle will eventually respond (2.6 seconds later). The driver's commands go not only to the lunar vehicle but also to an analog computer which controls the predictor "bug". The analog computer is adjusted to reflect the dynamic characteristics of the vehicle. As a result, the driver steers the predictor "bug" and lets the vehicle follow.

Braisted found that courses limited to a maximum speed of 2 mph without predictor could be driven at nearly 5 mph using the predictor. Braisted's work was aimed primarily at learning means of minimizing the performance degradation effects of time delay.

Remote Manipulator

In 1964, Ferrell^{27,28,62} reported on his studies of the effects of visual delay upon remote manipulation. He used delays of 0.3, 1, 2, and 3 seconds. His work is applicable to self-paced situations such as assembly, maintenance, and repair operations at remote locations.

This type work is in contrast to tracking tasks in which the operator is forced to pace himself in accord with that which he is either following (pursuit) or nulling (compensatory). Operators of the remote manipulator were able to pace themselves as they deemed appropriate. Ferrell found that there was a time-accuracy trade-off. He demonstrated that, with a delay, accuracy sufficient to perform difficult and complicated tasks can be obtained, but at the expense of time. The most successful strategy used by his operators was one of move-and-wait; the operator moves open-loop and then waits for knowledge-of-results before proceeding with his next move.

Ferrell reported that another possible strategy would be for the operator to move-slowly, but that such a strategy has distinct drawbacks:

1. It is difficult to estimate the future position of the slave hand a delay time ahead, even at low speeds, since one must keep track continuously of the movements of one's hand over the past delay period. If one moves too rapidly or loses track of previous movements, erroneous corrections are made and performance deteriorates.
2. Operators find that operating with the move-slowly strategy is more frustrating and emotionally upsetting than using the move-and-wait strategy.

Ferrell found that 8 out of 9 operators independently discovered and consistently used the move-and-wait strategy in preference to moving-slowly.

The latter finding is most important in light of reports by both Adams and Braisted. Adams found that his subjects often converted the continuous course (a composite of four

sinusoids) into discrete steps in order to provide a waiting period. Braisted summed his findings as follows: "When driving with a signal transmission lag (delay) and no predictor, the drivers found it helpful to steer in a burst of activity. Here they would command a large turn and then wait, if possible, to observe the results before making the next turn; driving performance improves when they have an opportunity to separate the job into a series of isolated maneuvers."

So all three researchers, Ferrell, Adams, and Braisted, have observed a natural tendency for operators, subjected to delay of visual feedback information, to move in a series of steps rather than in a continuous fashion. This may be a hint that systems being designed for use with long delays should operate in step fashion in order to take advantage of what appears to be a natural human tendency.

Real Time Tracking (No transmission delay)

Work has been done in the realm of "no-delay" that is pertinent to this thesis. Most of the work reported has been by researchers of two different backgrounds. One group, the servomechanism theorists and the other, the experimental psychologists. The former has looked at the problem of tracking from a mechanistic viewpoint and has attempted to fit man into the mathematical framework of their rather well established control systems theory. The latter group has been much more anthropocentric in their approach and have been attempting to learn the characteristics of human tracking behavior and the factors controlling them.

The Servomechanism Approach

One of the more outspoken proponents of this approach is Birmingham¹⁴ who stated that it is extremely useful to view a system under design, not as one to be operated by the human, but rather as an arrangement of components, one of which is the human, which operates to satisfy a purpose. He states that the pertinent human characteristics are:

1. Highly variable gain
2. Limited band width
3. A rather poor integrator, differentiator, etc.
(as compared to electronic or mechanical devices)
4. Source of noise in the system.

The majority of the work done by these control-oriented researchers has been with continuous input signals and compensatory tracking. These choices best fit their existing servo-control theories and provide greater mathematical tractability than would a choice of either step input, pursuit-tracking, or a combination of the two. These servomechanists have had a large measure of success in quantifying the behavior of a human operator in "real" time (no transmission-type delay) man-machine systems.

Tustin⁶⁸ during World War II was concerned with optimizing the man-machine aspects of the fire control system of a tank. He looked for an approximate mathematical law that would describe the main part of the operator's behavior in this application. He already knew the transfer function (the output response to a given input signal) for the equipment, and it was important that he also have a transfer function for the man in the system. He concluded that the operator behaved (mathematically speaking) as would the four following, serially coupled, electronic circuits:

- (1) Amplifier
- (2) Integrator
- (3) Phase-advance network
- (4) Time delay.

The amplifier term is reasonable because a person has the ability to adjust the amplitude of his response (as he sees fit) to a given input; he has an amplifier gain factor (K). The integrator term is more difficult: Tustin recognized that man's ability to move his hand was limited inversely by the rate (frequency) at which he had to respond. He knew that if the rate were sufficiently high, the person's response would approach zero. He concluded that the person's response must be proportional to the inverse of the frequency being tracked. (Unfortunately, Tustin was not completely correct; he neglected the fact that his analysis led to an infinite response at a frequency of zero cycles per second, and this is in conflict with experience.) Tustin's phase-advance network was a mathematical way of representing the anticipation ability of the operator: the man in the system has the capability of taking advantage of the rate of change of the input to get a "jump" on the tracking task. Lastly, the operator has a built-in, reaction-time-delay which must be taken into account.

Mathematical representation of the four terms is as follows:

$$H(s) = \frac{K(T_L s + 1) e^{-rs}}{s} \quad (1)$$

Where $H(s)$ = Operator transfer function as a function of s .

K = Operator gain
T_L = Operator phase-advance
(anticipation) time-constant
r = Operator reaction time
s = $j2\pi f$ where j is a complex operator = $\sqrt{-1}$
and f is the input frequency in cps.

At about the same time Tustin was doing his work, Phillips⁵² was concerned with ground control of fire against aircraft and adopted the same model for his operators. Licklider⁴⁶ reported that later researchers, Raggazini (1948), Russell (1951), and Walston and Warren (1954)⁷² adopted operator models that were similar to Tustin's (Equation 1).

In 1956, Elkind²³ reported on his experimentation in which he made major advancements in the development of a mathematical model for a human operator. He accepted the concept of gain, phase-lead network, and delay term that were covered by Tustin. But he corrected the fallacy of modeling the human response to approach infinity as the input signal goes toward zero cps. He agreed with Tustin that an operator's response approaches zero as the frequency approaches infinity, but he chose a simple, low-pass filter as a model for this human characteristic. Such a filter would do precisely what Tustin's integrator model would do after the frequency of the input had reached a so-called cutoff frequency. This cutoff is the break-point between a low frequency portion of the spectrum where the output of the filter is identical (in the ideal case) to the input and a high frequency portion where the output decreases in proportion to the inverse of the input signal frequency. This model was more in keeping with experience. Elkind concluded that the cutoff frequency was a function of the neuromuscular time lag of the human operator.

Elkind added an additional refinement --- a phase-lag network: just as the operator has the capability to anticipate a pending response, he also has the capability of holding back in his response. The latter he may choose to do to compensate for the dynamic characteristics of the equipment he is operating. Elkind's complete model is as follows:

$$H(s) = \frac{Ke^{-rs}(T_Ls+1)}{(T_Ns+1)(T_I s+1)} \quad (2)$$

Where $H(s)$ = Operator transfer function
 K = Operator gain
 T_L = Operator phase-advance (anticipation) time-constant
 T_I = Operator phase-lag (hold back) time-constant
 T_N = Operator neuromuscular lag time-constant
 r = Operator reaction time
 $s = j2\pi f$ where j is a complex operator = $\sqrt{-1}$ and f is the input frequency in cps.

Elkind recognized that a human operator, in mathematical terms, is a very non-linear element, but his model (Equation 2) is founded on the principle of linearity. The solution to this dilemma is to adopt a concept of quasi-linearity in regard to the model. That is, the coefficients of s are subject to variations both in time (learning, fatigue, boredom, etc.) and task requirements (control gain, rate, force, etc.), but for any given set of conditions, constant values can be chosen so that the model will approximately describe the tracking behavior of a person operating under those conditions.

Elkind designed an experiment for testing his model. He had his subjects sit directly in front of a 5 inch diameter cathode ray tube on which he presented a target (a dot $1/16$ inch in diameter) and a follower (a circle $1/8$ inch in diameter). In the case of pursuit tracking, the target was moved horizontally in accord with a predetermined "input" program and the subject controlled his follower so as to keep the dot circled. In the case of compensatory tracking, the dot was held stationary at the center of the screen, and the "input" program caused the circle to shift back and forth horizontally. The subject controlled the circle (by introducing a compensating signal) so as to keep the circle at the center of the screen. The "control" in Elkind's apparatus was a small, light weight and frictionless, pencil-like stylus that the subject moved across the screen of a second 5 inch oscilloscope. The latter was located in a horizontal plane in a position suitable for right-handed operators. The gains between the controller scope and the display scope were adjusted for a 1:1 correspondence. The maximum control/display movement was 1.0 inch rms; the input consisted of a composite of sinusoids.

For compensatory tracking, and with appropriate choice of constants for Equation 2, Elkind was able to show that at least 97% of the output power in the signal band is correlated with the input when the cutoff frequency is 0.64 cps or less. The correlation fell to about 90% when the cutoff frequency was increased to 0.96 cps, and for compensatory tracking to 2.4 cps the correlation dropped to less than 50%. He observed that tracking was very easy for both pursuit and compensatory types when the input was 0.16 cps or less, but became very difficult for frequencies higher than 1 cps. He observed that his subjects

consistently tracked wide band inputs with greater ease and greater accuracy using pursuit rather than compensatory tracking.

Noble, Fitts, and Warren⁴⁹ tested subjects for their ability to track a target which moves in a simple harmonic pattern. They found that subject performance decreased steadily as the input frequency was increased, and 5 types of changes in motor behavior contributed to this decrease:

- (1) Variability in phase
- (2) Variability in amplitude
- (3) Variability in the point of termination of successive flexor or extensor movements
- (4) A constant error in matching response amplitude to the average input
- (5) Loss of synchronization with the frequency of the input.

They concluded that these changes in performance are interpreted in relation to the hypothesis that man puts out a patterned response which he predicts will match the stimulus pattern, observes the output during a sampling period, and intermittently changes his output pattern. This conclusion is in agreement with Mayne's⁴⁷ statement that the human operator is, in some ways, comparable to a system consisting of a navigator and an auto-pilot. Under any one adjustment, the auto-pilot is approximately a linear system. It functions in a closed loop, the characteristics of which are readily measureable; however, the navigator sometimes changes the heading adjustment. This change alters the loop characteristic; the over-all system is therefore discontinuous.

McRuer and Krendel⁴² coined the phrase "pre-cognitive" tracking to describe man's ability to track a mentally

formed image of a periodic input. This process enables an operator to compensate for delays (including his own reaction time) when he has the task of tracking a periodic wave shape.

The Experimental Psychology Approach

Research by Craik²⁰ led him to state that, "The human operator behaves as an intermittent correction servo". The evidence for this is a periodic or wavy nature of time records of tracking errors. The period is somewhere between .25 and 1 second, but the most predominant period is .5 seconds. He said this error might be attributed to a sensory threshold or dead zone such that mis-alignments smaller than a certain amount evoke no movement, but there is evidence against this. Periodicity is present even when the display magnification is such that the mis-alignments are well above the visual acuity threshold and the periodicity does not change significantly when either the rate of course or magnification for a given course are altered. He says these intermittent corrections are ballistic movements - they have a predetermined time pattern and are triggered off as a whole and run their course. His work was a hypothesis and aimed at explaining continuous tracking behavior.

In a 1948 paper, Craik²¹ reported that the total time required for making a tracking decision is approximately 0.5 seconds where 0.2 is for simple reaction time. Of the remaining 0.3 seconds physiological studies show the response time of the eye and the time for impulses to be transmitted up to the optic nerve account for only 0.01 seconds. Electrical stimulation of the motor nerves and start of limb motion account for another .01 second, so Craik concluded that the remaining .28 seconds is

the time required by the cerebral process. He said that the refractory phase of .5 seconds limits the response to successive stimuli of about 2 per second. He says that stimuli at a higher rate are either disregarded, responded to later, or cause a general disturbance and conflict in the operator. The refractory phase is that brief period immediately following the response of a muscle, nerve, or other irritable element before it recovers its capacity to respond to a second stimulus.

The first major work with the refractory phase was reported by Telford⁶⁷ in 1931. He found that simple reaction time to an ordinary stimulus is considerably lengthened when the stimulus follows a preceding one at an interval of less than 1/2 to 1 second.

Hick³⁶ in 1948 reported that the refractory phase has been demonstrated unequivocally in discrete stimuli experiments and is probably also true in continuous tracking; there is a probability that the operator waits until there is a recognizable and relevant result from his previous response before considering the next. (This correlates with the findings of Ferrell, Adams, and Braisted reported earlier.) Hick performed an experiment that determined that man treats a series of closely spaced stimuli as one complex stimuli and responds in a single complex way, but his reaction time for this complex response to a complex stimuli is longer than it would be for a simple stimuli.

In 1949, Vince⁷¹ stated that corrective movements in a continuous tracking task are initiated, on the average, each half second. She said this rate appears to be a stable feature of the responses made in such tracking situations. She also reported on another experiment⁷⁰

in which she presented subjects with a rapid series of discrete stimuli. In this experiment, stimuli were presented as groups of black dots on a band of white paper on a drum which moved at 20 mm/sec. The drum was screened from the subject except for a narrow slit which was 3 mm wide. The subjects were required to respond to each dot by tapping once with a Morse key. The key was connected to an electro-magnetic marker which recorded their responses on the original program record directly below the row of stimuli. Each record lasted for 95 seconds.

Vince⁷⁰ found that performance deteriorated rapidly when the interval between stimuli was less than 0.5 seconds. She defined performance as the number of correct responses out of the total number possible for any given test interval. Her subjects responded successfully to approximately 90% of the stimuli when the interval was no shorter than .5 seconds whereas when the interval was decreased to .25 seconds, the subjects responded correctly to only about 45% of the possible maximum.

D. Highlights of Literature Search

1. Human behavior in man-machine systems which have delayed visual feedback
 - a) Tracking performance is degraded with transmission-type delays (Refs. 4, 5, 6, 8, 16, 17, 32, 73).
 - b) The degradation is a function of both the delay and course complexity (Refs. 4, 5, 6, 8, 16, 17, 32).
 - c) For delays of 0 to 320 milliseconds, there is an inverse linear relationship (hypothesized) between the logarithm of tracking time-on-target and the magnitude of the delay (Ref. 73).

- d) Predictors can be used to negate the deleterious effects of visual delays upon tracking performance (Refs. 8, 16).
 - e) Operators naturally adopt a move-and-wait strategy when confronted with delays of visual feedback information (Refs. 4, 5, 6, 8, 16, 27, 28, 62).
2. Real time (no delay) tracking behavior: Servomechanists' view
- a) Man's behavior is comparable to a low pass amplifier which has a built-in (reaction) time delay and, in some cases, lead and/or lag characteristics (Refs. 9, 10, 14, 23, 24).
 - b) Operator response, in a compensatory tracking situation, has a high frequency limit (low pass filter cutoff frequency) of approximately 1 cycle per second (Refs. 9, 10, 14, 23, 24).
 - c) Cutoff frequency is a function of the neuromuscular time constant of the operator (Refs. 9, 10, 23, 24).
 - d) An operator tends to mentally establish a pattern, and then track same until there is an adequate reason to change the pattern (Refs. 42, 47, 49).
 - e) Pursuit-type tracking is superior to compensatory for tracking wide frequency range input signals (Ref. 23).
3. Real time (no delay) tracking behavior: Experimental Psychologists' view
- a) Man has a refractory phase of approximately one-half second during which his movements are triggered off, as a whole, and run their course (Refs. 20, 21, 36, 70, 71).
 - b) The refractory phase limits an operator's corrective movements to a maximum of two per second (Ref. 20, 21, 36, 70, 71).

- c) Operator probably waits until there is a relevant result from his previous tracking command before considering his next (Ref. 36).
- d) Man's tracking performance is excellent for all inputs having an interval between successive stimuli that is greater than the refractory phase of approximately 0.5 seconds (Ref. 70).
- e) Tracking performance deteriorates approximately in proportion to the time interval (between successive stimuli) for those intervals shorter than the refractory phase (Ref. 70).

Chapter II

TESTS AND THEIR DESIGN

A. General

Results of the literature search indicated that operators of man-machine systems naturally adopt a move-and-wait strategy when subjected to a visual time delay of feedback information. It also indicated that pursuit-type tracking is superior to compensatory for tracking high frequency rate input signals. Advantage was taken of both finds in the design of an experiment for studying the effects of visual delay of feedback information in a man-machine system. A block diagram of the system selected is shown in Figure 1, and is repeated below for convenience:

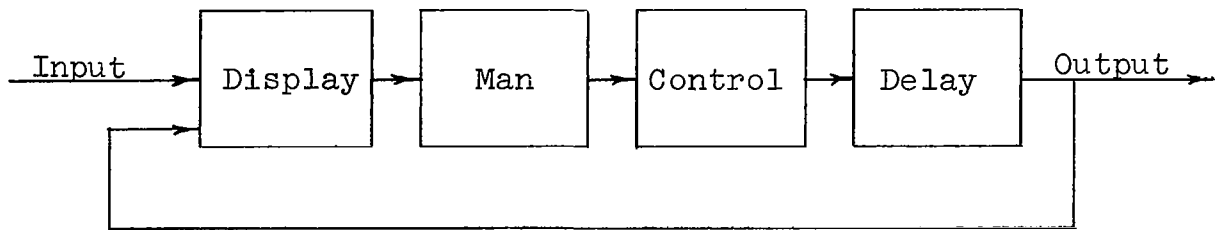

Figure 1

Pursuit-Tracking Block Diagram

Two types of input signals were considered: continuous and step type. It was thought that with either, an operator probably would resort to a series of discrete movements in order to minimize his difficulties with the effects of delay. It is important that tracking behavior be studied with each type of input, but there is little question that the use of the natural move-and-wait strategy is encouraged more with a step-type input than a continuous one. The input, or "course" to be tracked, had eleven

discrete positions. Courses, special ones for each delay, were programmed so that both positions and dwell periods at each position appeared in random order to the operator.

The operator had before him a display of both the input and his delayed output - each with eleven discrete positions. He controlled the output with a displacement type control; that is, a control in which the resultant output is correlated to the position of the control.

B. Hypotheses to be Tested

1. Under conditions of zero transmission delay, an operator pursuit-tracking a wide-band input has an upper cutoff frequency of approximately one cycle per second. (This hypothesis must be true if there is to be good correlation between this research and the work by others).
2. Under conditions of T seconds of transmission-type delay, an operator's upper cutoff frequency (f_c) is controlled by a move-and-wait strategy limitation; this frequency is equal to the inverse of twice the move-and-wait cutoff period (τ), or:

$$f_c = 1/2\tau$$

where τ = Transmission delay (T) plus
operator reaction time (r).

3. Tracking performance at frequencies below cutoff is reasonably predictable.

C. Approach to Experiments

A block diagram of the system is shown in Figure 2; this is, in principle, identical to Figure 1 but with the addition of a "performance recorder".

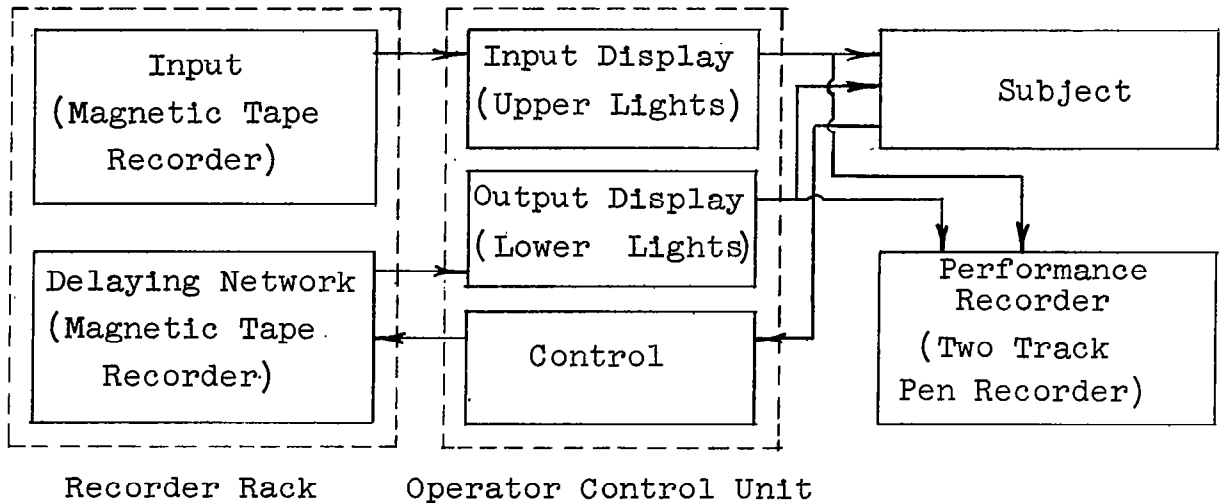

Figure 2

System Block Diagram

The installation is shown in Figure 3. The subjects sit before the Operator Control Unit (OCU); a "close-up" of the OCU is shown in Figure 4. The course to be tracked is the upper row of lights. They are illuminated individually by pre-programmed magnetic tape on the upper recorder (Figure 3). The subject tracks the "course" with the lower row of lights using the control located at the lower right of the Operator Control Unit. He controls both the order and the period of illumination of his lights through a time delay. This delay of T seconds ($T = 0.0, 0.27, 0.50, 1.0, 2.6, 5.0, \text{ or } 10.0$) is inserted by means of the lower recorder (Figure 3). The time delay is preset for each test by the experimenter; its value is determined by the

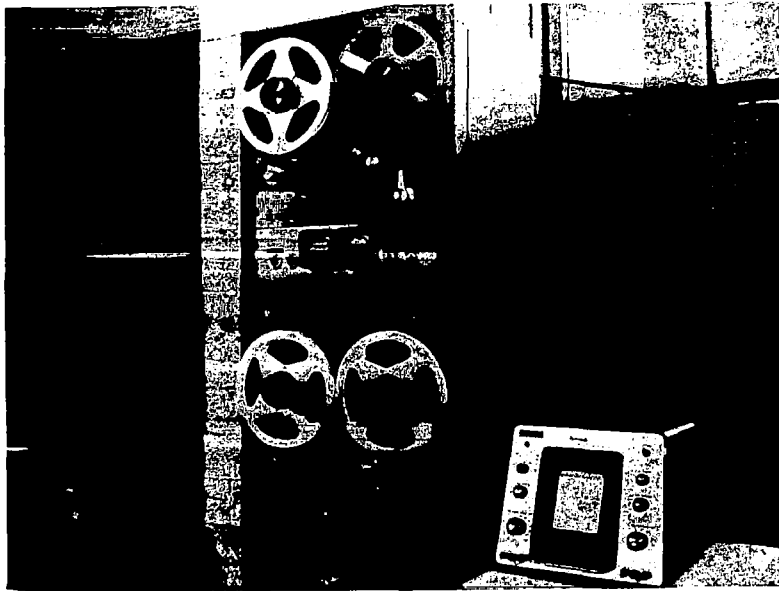

Figure 3
System Installation

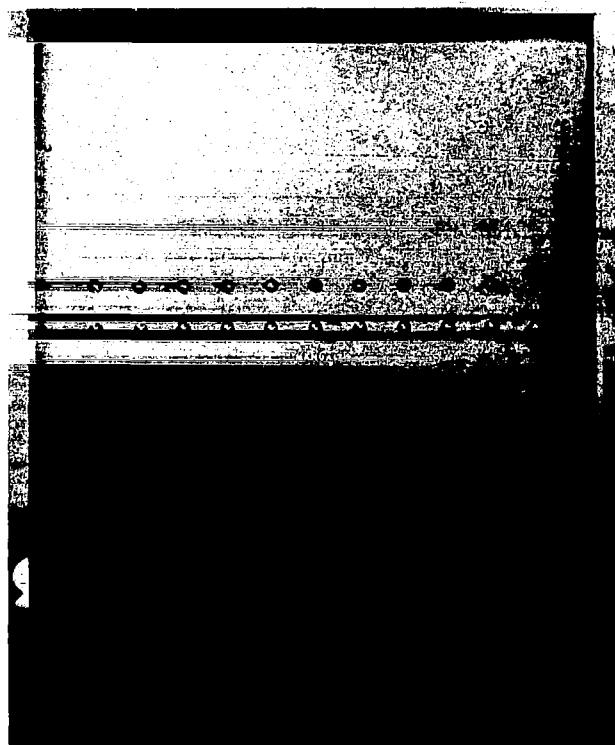

Figure 4
Operator Control Unit

length of the tape loop. Rollers to accommodate various lengths are visible in Figure 3.

Light-Illumination Programs

There were seven separate, pre-recorded tape programs used in the experiments. They were used in various combinations for each of the seven delay conditions. Each of the programs was individually designed to be a balanced "course" for a given delay. "Balanced" is intended to mean that the course complexity was approximately equally balanced between sections stressing the person beyond his performance limits and those sections that were well within his capability for tracking.

Delay T	Hypothesized Cutoff Period* $\tau = (T + r)$	Hypothesized Cutoff Frequency ($f_c = 1/2\tau$)
0.00	0.30	1.67
0.27	0.57	0.88
0.50	0.80	0.63
1.00	1.30	0.38
2.60	2.90	0.17
5.00	5.30	0.09
10.00	10.30	0.05

* For an assumed human reaction time of 0.3 seconds

Table 1

Hypothesized Cutoff Periods and Frequencies

Each of these programs was balanced about the hypothesized cutoff frequencies (or periods) shown in Table 1. These programs shall be referred to as the 0.00 Second Program, the 0.27 Second Program, etc.

The character of the visual input, or stimuli, to the operator's eyes is a series of discrete movements, i.e., light #6 (and only light #6) is lit, then #8 goes on (#6 goes off) and dwells for 4 seconds, then #2 goes on (#8 goes off) for .5 seconds, etc. The frequency connotation is from the dwell period of each light, the amplitude connotation is the distance of light-illumination movement, the maximum amplitude being light #1 to #11 (14 inches), and the minimum amplitude being between any two adjacent lights. Conversion between frequency and dwell period is defined as $f = 1/2D$ where D is the dwell period in seconds; D is also, in the language of the experimental psychologist, the interval between successive stimuli: the instant a given light turns on, the subject receives a signal to track his row of lights to that position, when that same given light turns off (another simultaneously turns on) he receives a signal to track to the next. Hence, light-illumination period, light dwell period, and interval between successive stimuli are synonymous terms. The schedule of dwell periods for the programs is shown in Table 2.

Program	Dwell Periods (Seconds)							
0.00	4.00	1.00	0.45	0.30	0.20	0.14	0.10	
0.27	4.00	1.50	0.75	0.45	0.30	0.20	0.14	
0.50	4.00	2.00	1.00	0.50	0.33	0.27	0.20	
1.00	12.00	4.00	2.00	1.25	0.75	0.50	0.33	
2.60	12.00	6.00	4.00	2.50	1.50	1.00	0.75	
5.00	25.00	12.00	6.00	4.00	3.00	2.00	1.00	
10.00	50.00	25.00	12.00	7.50	5.00	3.50	2.00	

Table 2
 Schedule of Light-Illumination
 Dwell Periods

In testing for the effects of visual delay of feedback information, it is important to minimize the possibilities of accurate anticipation of the next light, or sequence of lights. Such anticipation is prevalent in tracking periodic wave shapes. A subject can track a constant amplitude, constant period wave nearly as well with delay as without; he merely anticipates the wave T seconds ahead of a T second delay. So, to achieve the effects being studied, it became necessary to eliminate anticipation by randomizing both the occurrences of the dwell periods and positions of the light-illuminations.

For each program, seven dwell periods were each tested ten times; so each subject was required to track 70 different light positions for each run of a program.

The light-illumination programs are shown in Appendix A. The length of each program is a function of the dwell periods used for the particular delay for which the program was designed. The length of time required for each program is shown in Table 3.

<u>Program</u>	<u>Length (Minutes)</u>
0.00	1.03
0.27	1.24
0.50	1.38
1.00	3.48
2.60	4.63
5.00	8.84
10.00	17.50

Table 3

Program Running Time

Test Phases

The experiment was divided into 4 phases:

Phase 1: Balanced Program Tests for Performance versus Delay: light-illumination dwell periods (the interval between successive stimuli) were approximately balanced in number between those longer than the hypothesized cutoff and those shorter.

Phase 2: Short Dwell Period (High Frequency) Tests for Evaluating the Effects of Course Complexity: light-illumination dwell periods were predominantly shorter than the hypothesized cutoff period.

Phase 3: Learning Tests:

Same Course (0.5 Second Program) tracked repeatedly by operators to observe learning behavior.

Phase 4: Open-loop Tests:

Same Course (0.5 Second Program) tracked repeatedly by the operators under conditions of no visual feedback to observe open-loop performance.

Performance Versus Delay (Phase 1)

In the experiment, major emphasis was placed upon the Phase 1 Tests. These tests used the balanced course programs discussed previously. The objectives of the Phase 1 Tests were aimed at learning answers to the following:

1. How well are subjects able to pursuit track a course that provides ample time for applying the move-and-wait strategy?

2. What is their performance degradation when forced to track at a rate beyond the move-and-wait strategy limit?
3. Where is the cutoff point between these two extremes?

Effects of Course Complexity (Phase 2)

The Phase 2 Tests were purposely biased in the direction of forcing the subject to operate beyond his cutoff point. The 0.0, 1.0, and 2.6 Second Programs were used for these tests but with longer delays than those for which they were originally designed. The programs used with each delay in the Phase 1 and 2 Tests are shown in Table 4.

<u>Delay (Seconds)</u>	<u>Programs - Phase 1</u>	<u>Programs - Phase 2</u>
0.00	0.27	0.00
0.27	0.27	0.00
0.50	0.50	0.00
1.00	1.00	0.00
2.60	2.60	1.00
5.00	5.00	1.00
10.00	10.00	2.60

Table 4

Program Schedule: Phases 1 and 2

Phase 2 Tests provided opportunity to study:

1. Effect of course complexity upon tracking performance at a given delay.
2. Effect of different delays upon tracking performance with a given course.

The combined Phase 1 and 2 Tests allowed observation of two different programs at each delay, the 0.00 Second Program at four different delays, the 1.00 Second Program at three

different delays, and the 0.27 and 2.60 Second Programs at two different delays.

Learning (Phase 3)

The Phase 3 Tests were part of a limited study of the effects of learning in the experiment. In the design of Phases 1 and 2, it was recognized that a learning period was required by each subject at each delay condition. The experiments were designed so that each subject went through an unscored period for each delay just prior to running the Phase 1 and 2 Tests at that same delay. Each of these learning periods was approximately one half the time duration of the Phase 1 Program for that delay. The course programs for these learning sections were designed in exact accord with their Phase 1 counterparts. They too had light dwell periods and positions that were established from random-numbers tables. The bias effects of learning were reduced in Phases 1 and 2 by randomizing the order of presentation of the different delays to the subjects.

For Phase 3, subjects tracked the 0.5 Second Program ten consecutive times. Observation of their respective performances in tracking successive runs showed the effect of learning with this one program.

No attempt was made to study the effects of transfer of learning with one delay to tracking behavior with another. The "transfer effect" was not considered unimportant, but it was felt that the effects would be sufficiently small to justify a postponement of study of same until a future date.

Open-Loop Performance (Phase 4)

A serious question is raised when one considers tracking behavior at frequencies higher than the limits imposed by the move-and-wait strategy. The subject is forced to move a second time (and maybe a third) before he receives knowledge-of-results. So the question is as follows: under these conditions, to what extent does the subject approach "open-loop" performance? Phase 4 was aimed toward answering this. The same subjects involved in the Phase 3 tests were given the task of tracking the 0.5 Second Program five consecutive times under the condition of no visual feedback (the lower row of lights were masked). They handled this assignment immediately following the Phase 3 Tests.

Since Phase 4 always followed Phase 3, the results can be assumed to be biased in favor of the open-loop tests.

Subjects and Tests

Thirty-six Stanford University students were used in the four phases of tests. None had had prior experience with design or construction of the experiment or experimentation equipment. They were in the 20 to 30 age bracket and were right-handed.

Subjects 1 - 31 were involved with the Phase 1 and 2 tests, and subjects 32 - 36 with Phases 3 and 4. Subjects 1 - 6 performed only half the tests (see Appendix B); they were used as a pilot run for evaluating the system. Their tests required 51 minutes per subject; the full bank of tests taken by subjects 7 - 31 required 72 minutes. The data of the first six showed no peculiarities that warranted the exclusion of it from the final averages.

The total testing program associated with Phases 1 and 2 included the administering of 392 tests to thirty-one subjects. From this number, nineteen tests were lost because of either equipment malfunction or mistakes by the experimenter. No subjects were "re-runs" to recoup lost data.

The experimental data, including the nineteen gaps, appear in Appendix B.

D. Equipment

The number of discrete steps for the input-signal display was chosen at five steps each side of a center position. This was a compromise between a desire for many steps to improve the chances for correlation with continuous inputs and a desire for few steps to aid the subject in distinguishing between steps.

Numerous display approaches were considered, but the eleven electric light bulb approach seemed the most appropriate. Lights readily lended themselves to providing a large display for the subject, and largeness has the advantage of minimizing his doubt as to the exact location of the light that is lit.

The light-illumination display system was designed around two audio-type magnetic tape recorders. One was used for programming the upper row of lights (Figure 4), and the other was used for inserting a delay between the subject's control-commands and the lower row of lights. For either recorder, the character of the recorded signal on the magnetic tape is the same: a series of bursts of constant amplitude, constant frequency, audio tones. Each burst was associated with the illumination of a given

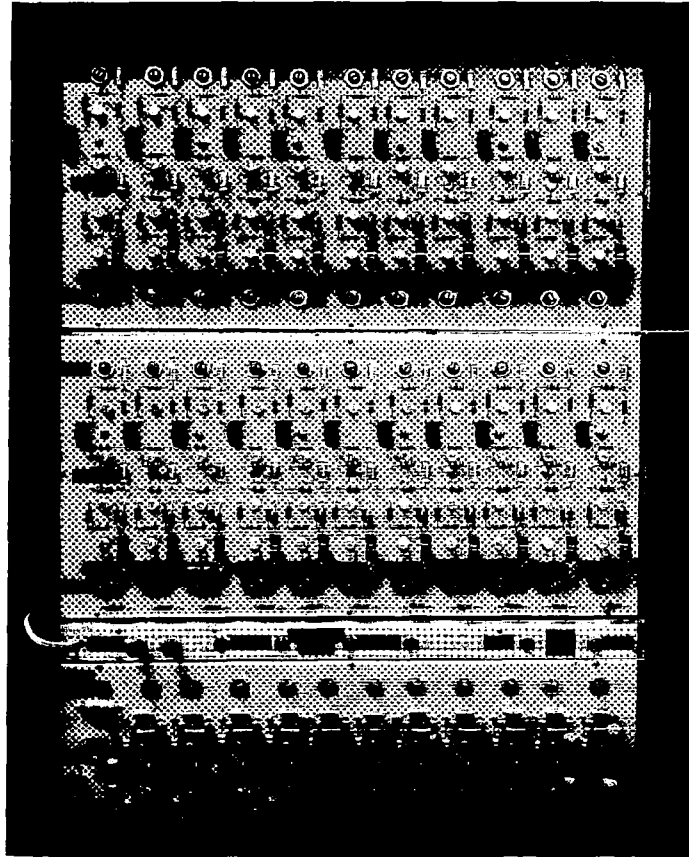
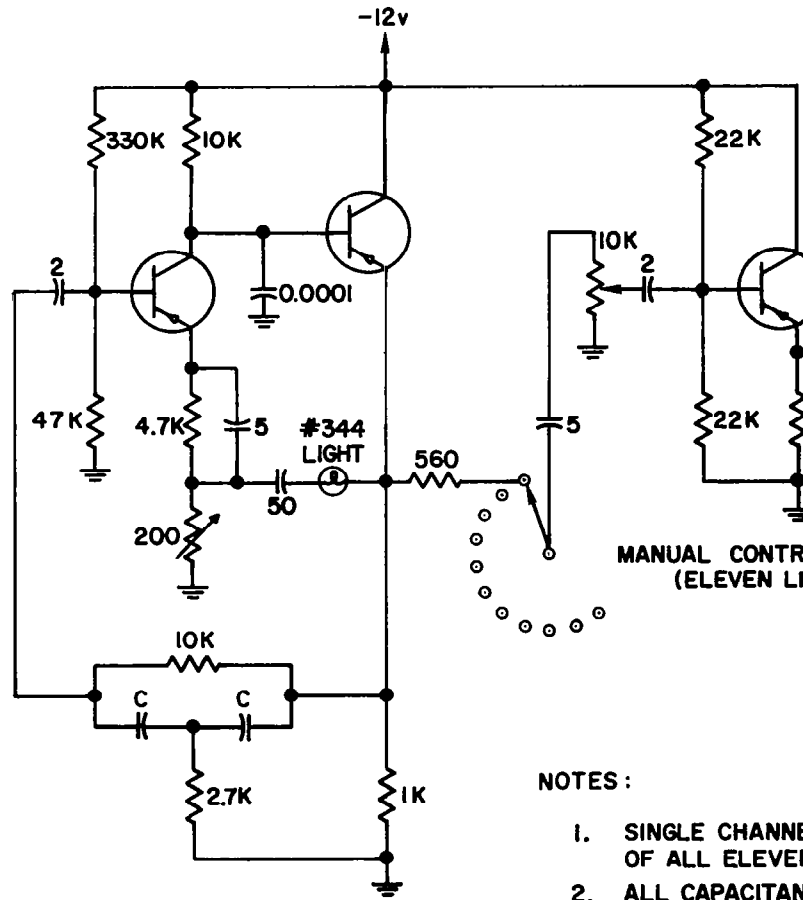

Figure 5

Rear - Operator Control Unit

LIGHT	FREQ. (cps)	C (mfd)
1	85	0.37
2	138	0.27
3	215	0.14
4	330	0.085
5	520	0.052
6	950	0.027
7	1400	0.018
8	2450	0.0096
9	3800	0.0060
10	7100	0.0030
11	11000	0.0019



- NOTES:
1. SINGLE CHANNE OF ALL ELEVEI
 2. ALL CAPACITAN
 3. ALL TRANSISTO

Figure 6

Frequency Generators - Operator Control Unit

light, so there were eleven discrete frequencies involved in covering the full range of lights.

Frequency Generators

The special electronics for the system are located at the rear of the Operator Control Unit (Figure 5). The lower section includes eleven separate Wien-bridge oscillators to provide the light-illumination frequencies. Output of each of the oscillators is to a multiple position switch that is the operator's control; it is located at the lower right of the Operator Control Unit (Figure 4). The frequency at the switch output is a function of the position of the control. The schematic for a typical oscillator and accompanying circuitry is shown in Figure 6.

Frequency Sensing Circuits

Each of the other two sections of electronics (Figure 5) energize individual lights in accord with the burst frequency present at its input. The upper section is associated with the upper tape recorder (Figure 3) and upper row of lights (Figure 4); the middle section with the lower recorder and lower row of lights. Both sections are identical. Each consists of eleven separate channels where all channels are identical to one another except for the values of two elements in a frequency sensing circuit.

The schematic for a typical single channel is shown in Figure 7. The circuit consists of a tuned amplifier which has L and C values chosen to provide peak amplification at the appropriate burst frequency. The amplified signal is then fed through an emitter-follower isolation stage to an amplitude detector that converts the oscillating input to a dc voltage for triggering a Schmidt

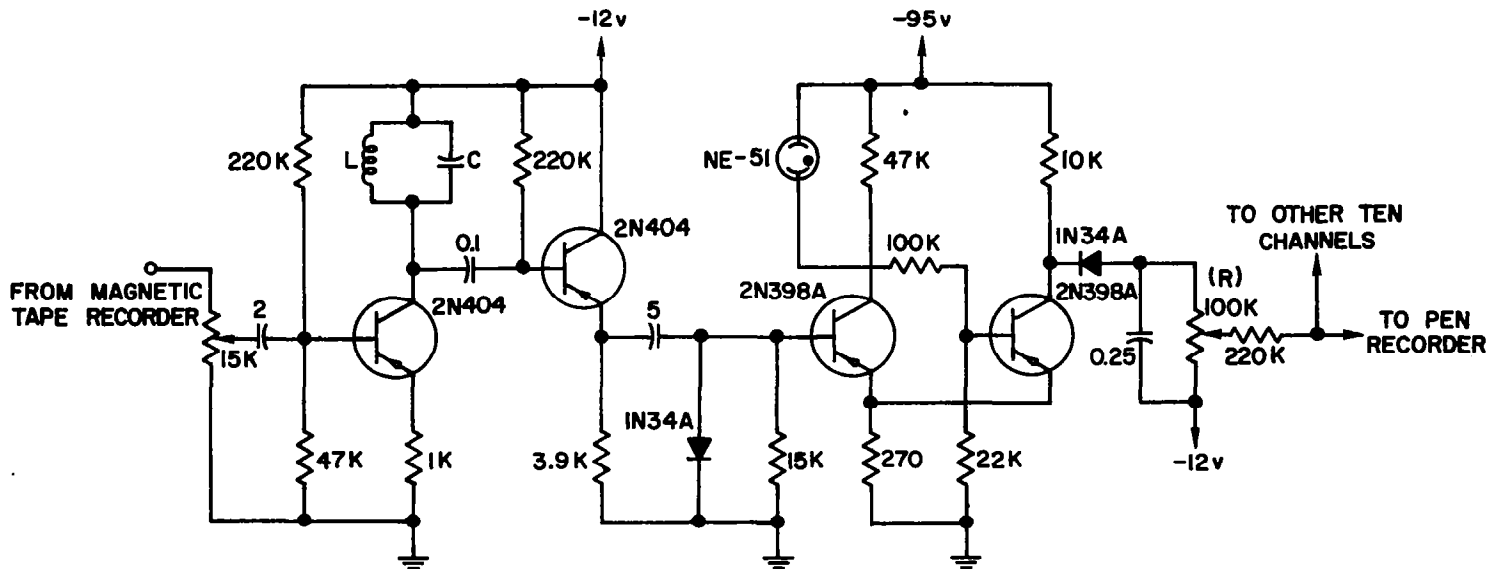

35

LIGHT	FREQ.(cps)	L (hys)	C (mfd)
1	85	2.6	0.130
2	138	2.6	0.52
3	215	2.6	0.21
4	330	2.6	0.073
5	520	0.3	0.31
6	950	0.3	0.093
7	1400	0.3	0.043
8	2450	0.3	0.014
9	3800	0.3	0.0060
10	7100	0.3	0.0017
11	11000	0.076	0.0028

NOTES :

1. SINGLE CHANNEL SHOWN AS TYPICAL OF ALL ELEVEN EXCEPT FOR L AND C.
2. ALL CAPACITANCE VALUES IN MICROFARADS.

Figure 7

Frequency Sensing Circuits - Operator Control Unit

trigger circuit. The latter acts as a toggle switch to control the voltage to a NE-51 type neon light: if a trigger voltage of over a certain minimum amplitude is present, the light is flipped "on", if the input amplitude to the Schmidt trigger drops below a minimum, the light is flipped "off". The latter circuit not only acts as a silent and fast acting light switch, but it also provides a source of steady dc voltage that is present whenever the particular light is illuminated. Adjustment (R) was made so that each channel has a unique value of voltage associated with illumination of its light. These voltages (from each of two sections) were fed to the appropriate channel of a Brush Mark II pen recorder.

Transmission-Type Delay

The lower of the two recorders (Figure 3) was equipped with a series of rollers to accommodate different lengths of tape between the magnetic record head and the playback head. The subject's control commands were put on tape at the record head and were delayed by the length of time required for the tape to traverse the rollers and reach the recorder's playback head. The length of loops varied from a 2" minimum spacing for 0.27 second delay to a maximum of 75" for 10 second delay. For zero second delay, the recorder was by-passed.

Manual Control

This was one of the greater problem areas in the system

changes involved in operating controls; (3) tactile feedback from a multitude of different sources (and many of them may be subconscious), i.e., location of set screws in knobs, a nearby object (perhaps another knob) that is either touched or brushed during the controlling task, etc. Still another form is proprioceptive feedback: a person doesn't have to either look at his finger or touch something to know which direction he is pointing; this latter form of feedback is ubiquitous in every man-machine system. And, of course, there is the well recognized visual feedback.

Since this thesis was concerned with the effect of delay of visual feedback, it was imperative to reduce other forms of feedback to a minimum to avoid their paralleling effect; the latter would have distorted the effect being sought.

Auditory feedback was eliminated by not using relays, detented switches, or other noise producing devices that would be related to the manual-control position. Kinesthetic feedback was minimized by making the control very lightweight and nearly frictionless. But proprioceptive feedback was not so easily minimized: it was learned during preliminary testing of the equipment that the subjects will naturally seek out proprioceptive feedback cues as a means of either minimizing or avoiding the mental frustrations of tracking with a delay of visual feedback information. This proprioceptive feedback is maximum when there is one-to-one correlation between the positions of the control and the display. For the preliminary tests of controls, full range rotations of 90, 180, and 270 degrees and knob diameters of 1/4 to 4" were tried; in each case the subjects (five total) resorted

to the strategy of firmly grasping the knob and mentally imagining a pointer connected to the knob (or their hand) which they could correlate with light position. With such strategy, they soon could ignore the lower row of lights. As one of the subjects said, "Once I have used the lower row (of lights) to establish calibration, I could do much better if you would turn them off. I find their delayed response more confusing than aiding". Another of the subjects said, "Put in any delay you want to - it won't bother me - I'm not using the lower row of lights anyway!" The manual control had to be designed so as to minimize the use of such strategy.

The final design of control used a 3 3/8" diameter knob that was located behind a slotted (or windowed) panel (Figure 4). The design forced the subject to use finger tip control. Furthermore, the control required a 180° rotation to move the light illumination from #1 to #11 position; the slot dimensions in the panel allowed only 60° rotation unless the subject moved his finger (or fingers) to another location. This complication added to the fact that the control had no stops, was light weight, nearly frictionless, and identical to the touch anywhere along its periphery made for poor kinesthetic, tactile, and proprioceptive feedback. The subject had to rely heavily on visual feedback throughout the tests to keep himself calibrated.

The problem of possible conflict between visual and kinesthetic/tactile feedback was recognized by Elkind²³ who said, "It was assumed that only visual stimuli are important and that the human operator obtains little useful proprioceptive or kinesthetic information about the position of his hand. With a light and frictionless control this assumption is not too drastic".

Since Elkind used a 1:1 relation between his control and display (reported earlier), one must question the validity of Elkind's assumption. The saving grace is that he was not working with delays external to the operator. In reality, he studied tracking behavior with visual, kinesthetic, and proprioceptive feedback; without external delay there was negligible conflict between these different forms of feedback.

E. Test Procedures

All subjects were given identical verbal indoctrination. They were told the following:

Subject Indoctrination

1. The experiment is to study man's behavior when subjected to visual delay of feedback information.
2. The subject is of interest because of:
 - a) Future needs of remotely controlled equipment in space.
 - b) Possibilities of learning more about the effects of human reaction time delays by exaggerating these effects through external delays.
3. The problem is one of tracking: The upper row of lights are pre-programmed from magnetic tape; they (the subjects) have control over the lower row of lights.
4. They are to match (in proper sequence) the light positions of the upper row with their lights in the lower row.
5. They are to try to also match the periods of light-illumination as best they can, but this is secondary in importance to matching the positions.

6. Delays (0.0 - 10.0 seconds) will be inserted between their control and their (lower row) lights; they will be informed of the delay and given a warm-up period at that delay.
7. The delay tests will be presented in random sequence.
8. Some of the input-light moves will be so fast that they cannot be followed; don't worry about it, but try to follow as best as possible.
9. Use a rigid finger technique for moving the control.
10. Touch only the control; try to avoid touching the periphery of the window opening.
11. Place the pillow under elbow in as comfortable a position as possible.
12. A few minutes break can be taken between tests if desired.

The above twelve point indoctrination was followed precisely for Phases 1 and 2 subjects; for Phases 3 and 4, point 6 was modified to be "all tests will be with a single program and a single delay (0.5 seconds)" and point 7 was deleted.

Order of Tests

Phases 1 and 2 were treated as a single bank of tests. The seven programs were on a single roll of magnetic tape; it was fast wound to the sections as dictated by the random order selected for the subject. At each delay, the subject first went through the warm-up period, then the Phase 1 Test and finally, the Phase 2 Test.

For Phases 3 and 4, subjects tracked the 0.5 Second Program with visual feedback (Phase 3), and then immediately ran additional tests without visual feedback (Phase 4).

Chapter III
RESULTS OF TESTS

A. General

Results of the Tests of Phases 1, 2, 3, and 4 are presented, in order, in this section. The results from the individual phases will be discussed as they are presented, but discussion pertaining to the interrelation of the different phases will be reserved for Section IV. "Discussion of Results".

In the following presentations of Phases 1 and 2 test results, the data has been plotted on semi-logarithmic paper in accord with well-founded conventions of the servo-mechanism field. The horizontal scale is logarithmic in terms of frequency; the vertical scale is linear, but the data is plotted logarithmically. With such a plot, any two quantities that have an inverse relation to each other will appear on the graph as a straight line.

The raw data for the Phase 1 and 2 graphs is shown in Appendix B. The data has been manipulated for graphical display as follows: the "Interval D Between Successive Stimuli" has been converted to its frequency equivalent $f = 1/2D$; this has been plotted as the abscissa for the graphs. A number of the intervals (D) also have been shown along the top of each sheet. The ordinate of each graph is plotted as $20 \log_{10}$ of the mean performance ratio. Mean performance and mean standard deviations, along with the individual subject scores, are shown in Appendix B.

Scoring

Scoring was based on a hit-or-missed approach. The primary goal of each subject was supposed to be to track positions of light-illuminations (see Test Procedures); their secondary goal was to match dwell periods. Some subjects chose a cautious approach of moving, in a series of steps, to their eventual destination; others would take a large step (and sometimes overshoot) and then correct with a smaller step or two; and there were those who would make a half-hearted attempt to hit the lights with short dwell periods, and then lay-in-wait for the longer ones. The latter were particularly difficult to score because often it was not clear as to which light they were attempting to hit. Scoring on a hit-or-missed basis seemed to be a practical solution to the dilemma. This approach provides a measure of a subject's degree of success in tracking positions he is supposed to track, but it does not give a measure of the distance by which he misses.

A subject was scored on the basis that he had 10 opportunities to hit each of the seven different dwell periods presented to him in each test. If he hit all 10, his score would be 1.00; if he hit only 7 of the total possible (10), his score would be .70 etc. The experimental data in Appendix B is presented on this basis.

B. Performance versus Delay (Phase 1)

A minimum of 23 subjects were involved in the test program for Phase 1. The subjects pursuit-tracked seven different programmed courses, one for each of seven different delays: 0.0, 0.27, 0.50, 1.0, 2.6, 5.0, and 10.0 seconds. Each of the courses was intended to be approximately balanced about the hypothesized cutoff point for the respective delay.

The experimental data is graphed in Figures 8 through 14. (The Figures also show Phase 2 data which will be discussed later).

All seven graphs show that performance is best at the longer intervals between successive stimuli, or synonymously, lower frequencies.

The graphs also show a trend for performance to deteriorate with increases in transmission-type delays. This degradation can be observed better in Figure 15 which shows the Phase 1 experimental results as a family of graphs. If the cutoff frequency is defined as that point where the performance ratio falls to 0.707, then $20 \log$ of this ratio equals -3.

So the intersection of the -3 ordinate and each of the graphs in Figure 15 mark the cutoff frequency for that delay. There is precedent for picking the ratio of 0.707: performance of low pass filters, which have a single frequency-dependent element, have a natural breakpoint at a frequency where the output amplitude is 0.707 of the input. The breakpoint would appear, on the type of plot being used, as the intersection of a horizontal line through an ordinate of 0 and a line having a negative 45° slope through those performance points well beyond cutoff.

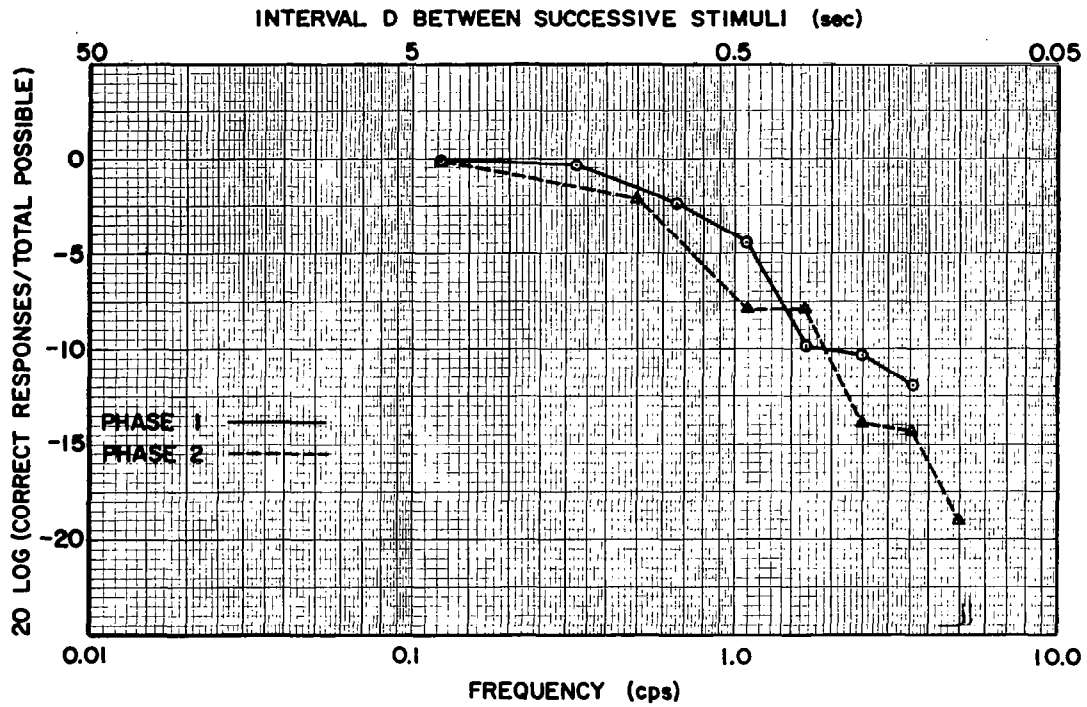

Figure 8 - Phases 1 and 2 Tracking Performance:
0.00 Second Delay

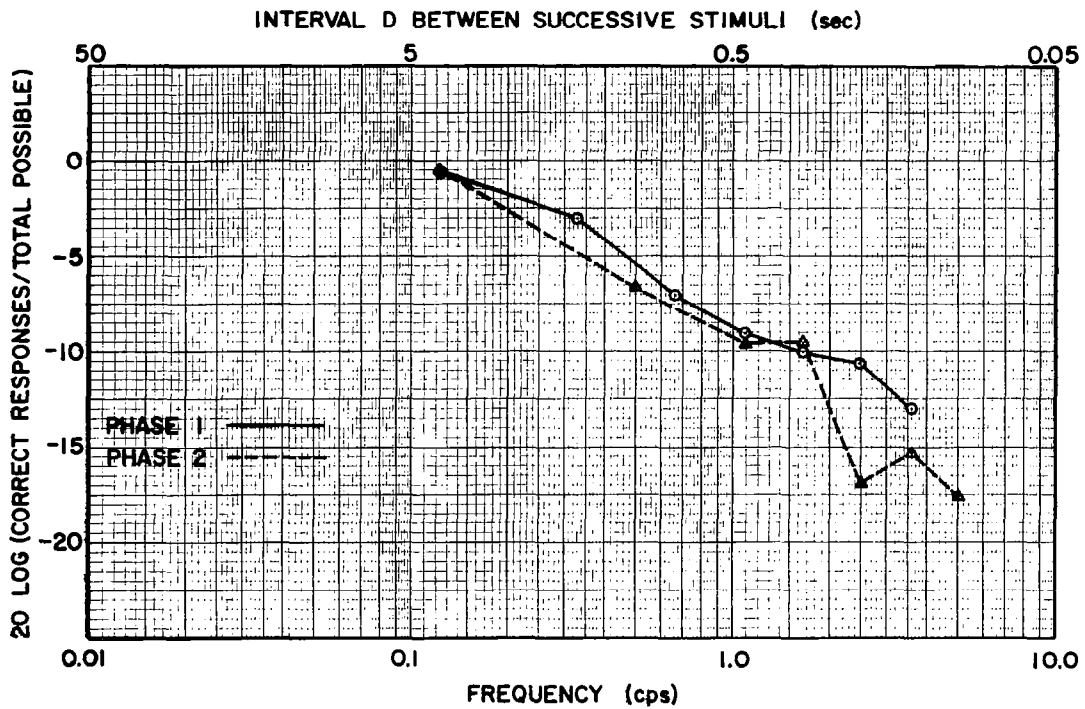

Figure 9 - Phases 1 and 2 Tracking Performance:
0.27 Second Delay

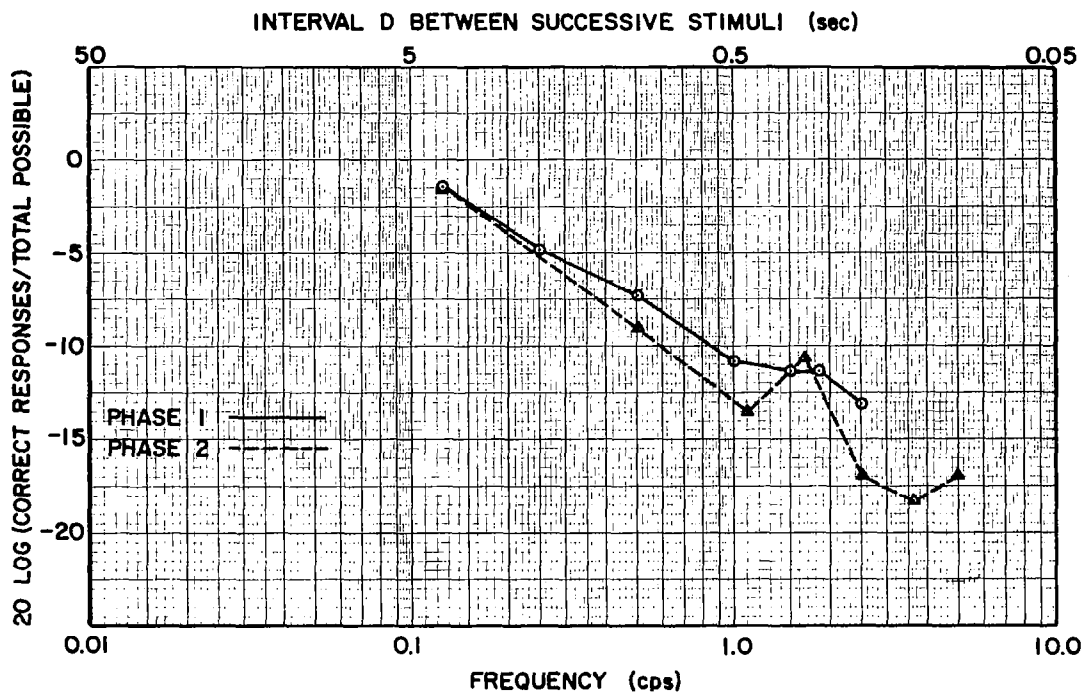

Figure 10 - Phases 1 and 2 Tracking Performance:
0.50 Second Delay

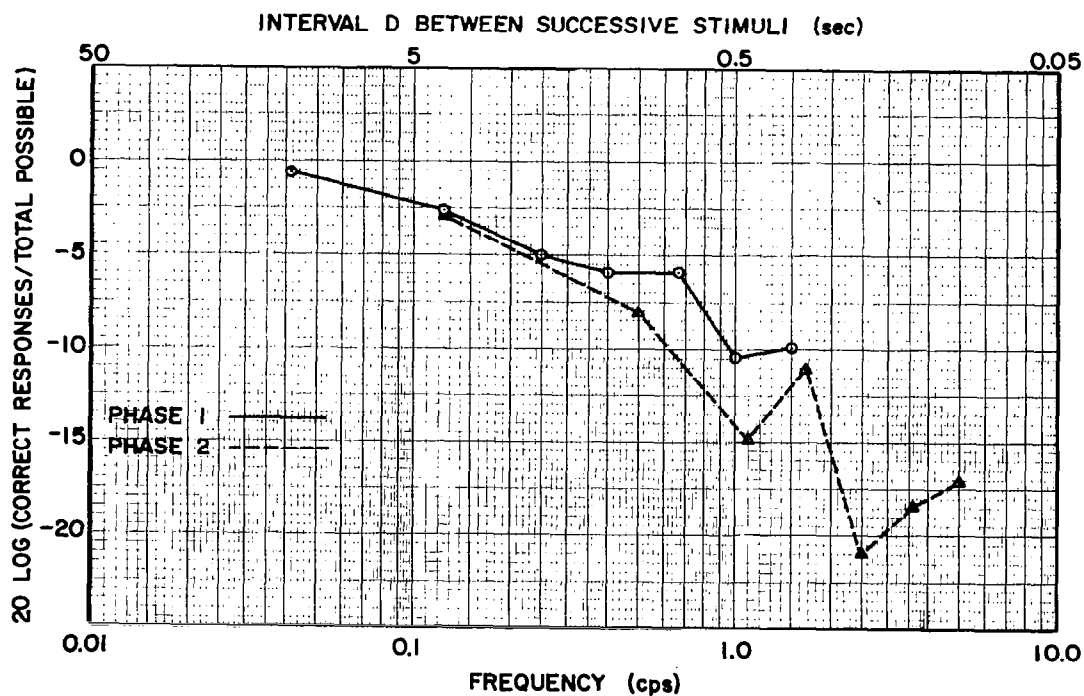

Figure 11 - Phases 1 and 2 Tracking Performance:
1.00 Second Delay

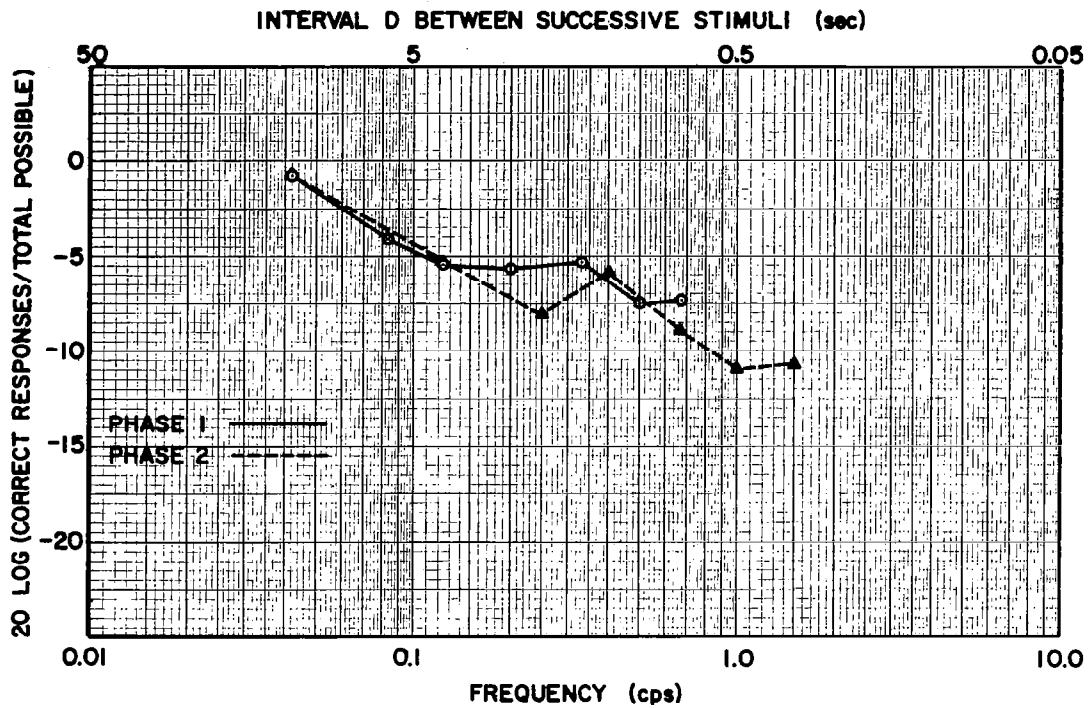

Figure 12 - Phases 1 and 2 Tracking Performance:
2.60 Second Delay

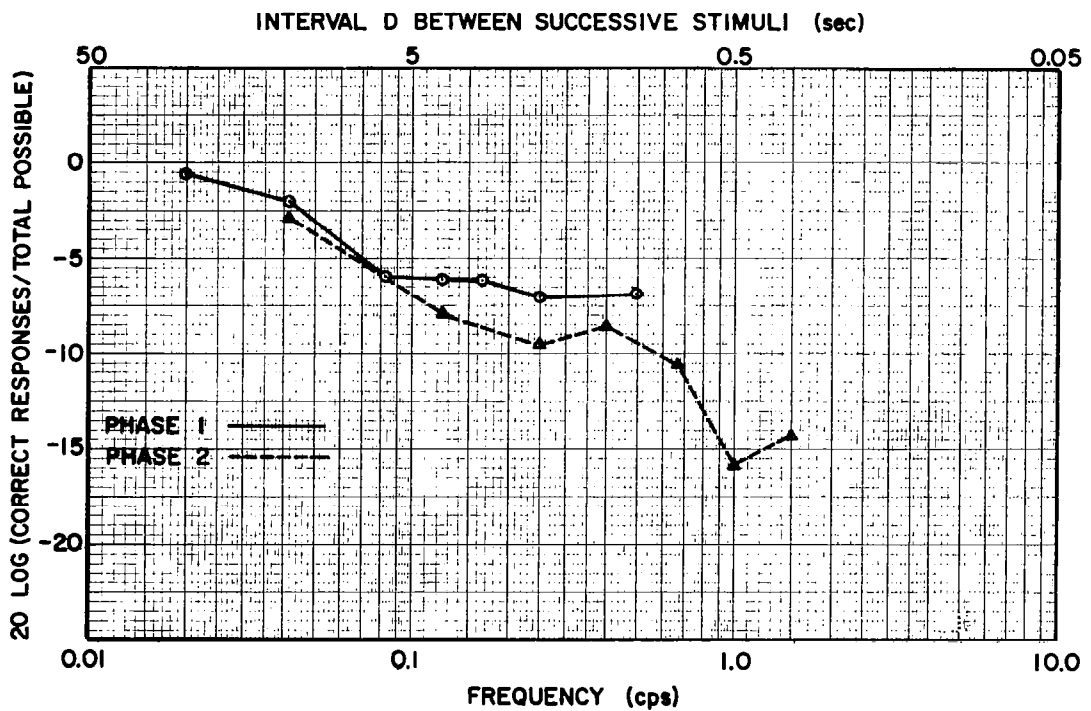

Figure 13 - Phases 1 and 2 Tracking Performance:
5.00 Second Delay

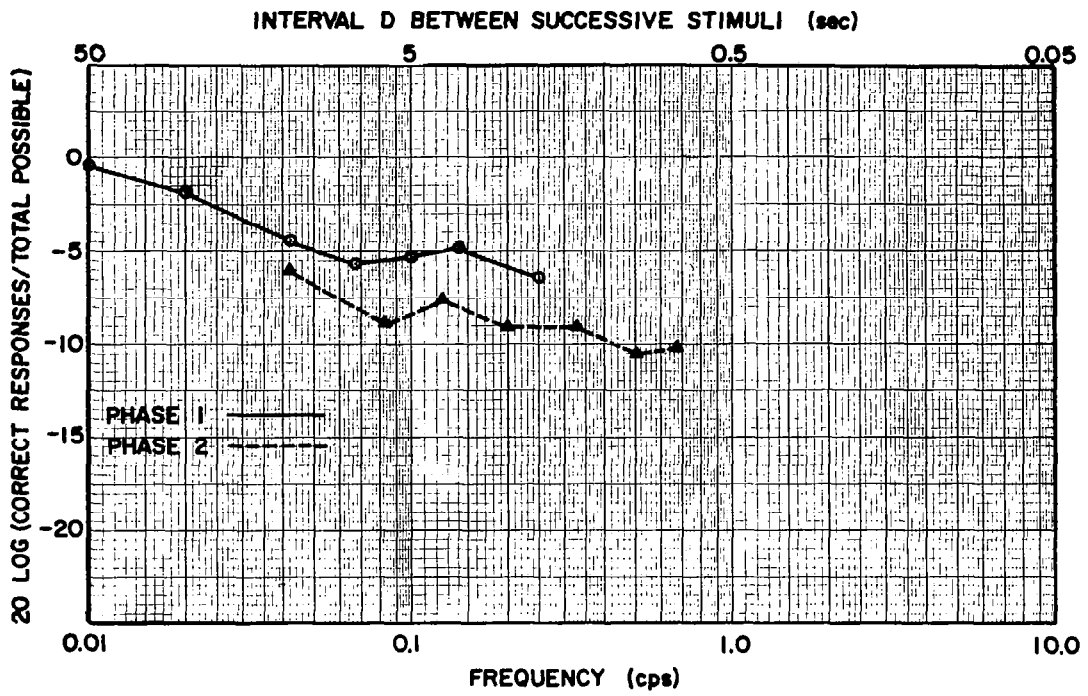

Figure 14 - Phases 1 and 2 Tracking Performance:
10.00 Second Delay

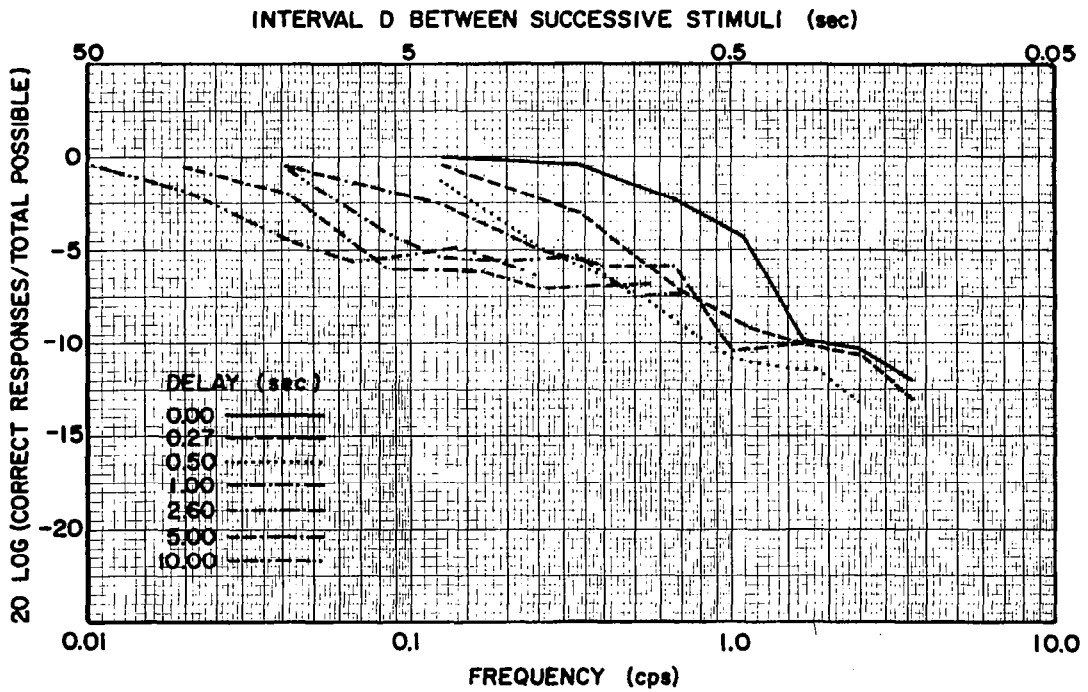

Figure 15 - Phase 1 Tracking Performance: Composite

Delay T (Seconds)	Cutoff Frequency (Cycles/Second)	f_{co}	Cutoff Period D* (Seconds)
0.00	0.78		0.64
0.27	0.33		1.5
0.50	0.18		2.8
1.00	0.14		3.6
2.60	0.066		7.5
5.00	0.050		10
10.00	0.028		19

* $D = 1/2f_{co}$

Table 5

Measured Cutoff Points: Phase 1

Table 5 shows both the measured cutoff points (as picked from Figure 15) for each of the given delays. Clearly, this cutoff frequency is seriously affected by transmission-type delays. Even that which is approximately equal to human reaction time (0.27) seconds) lowers the cutoff frequency to less than half that for "real" time (0.00 second delay). A delay equivalent to that which would prevail in remotely controlling a vehicle on the moon (with its operator on earth) would decrease the performance cutoff by an order of magnitude from that which would exist without the 2.6 second delay. For the case of no external delay of visual feedback information, the cutoff frequency for Phase 1 Tests was 0.78 cps. This is lower than an expected cutoff of 1 cps; this, and other comparisons of results to hypotheses, will be covered in Section IV.

c. Effects of Course Complexity (Phase 2)

A minimum of 22 subjects participated in this Phase. These subjects, without exception, were also involved in the Phase 1 Tests. All conditions were identical to those of Phase 1 except for the complexity of the programmed courses. For

this Phase, they tracked the 0.00 Second Program at 0.00, 0.27, 0.50, and 1.00 seconds delay; the 1.00 Second Program at 2.60 and 5.00 seconds; and the 2.6 Second Program at 10.0 second delay. For each of the tracking tasks, the subject was presented with a "course" having light-illumination dwell periods that were predominately shorter (higher frequency) than the hypothesized cutoff point.

Mean performance results for Phase 2 are shown in Figures 8 through 14. Each of these Figures show the performance results of subjects tracking two different courses at the same delay. In each case, the Phase 2 course is purposely more difficult than the Phase 1. Figures 8 through 14 show subject performance to be generally poorer with the more complex Phase 2 course.

The Phase 2 results can best be explained in terms of the composition of the two programs tracked at each of the delays and the hypothesized cutoff period associated with that delay.

Table 6 shows that an operator has more opportunities to exercise a move-and-wait strategy with Phase 1 Programs than with Phase 2. In the case of Phase 1, he has three (or four at the most) dwell periods for each delay that are sufficiently long to allow use of the strategy. For Phase 2, he has fewer. Obviously, he has a better chance in the Phase 1 Tests of keeping himself calibrated than with Phase 2; i.e., he is in a much better position of knowing how much to turn the control to hit those lights having a dwell period of less than one delay time. If the number of dwell periods shorter than cutoff were identical for Phases 1 and 2, it would be reasonable to expect the average subject performance to be better for Phase 1 Tests than for Phase 2. If the tracking task is made still more difficult by increasing the number of dwell periods that are shorter than the cutoff period, there is little doubt that the tracking performance would

Delay (Second)	Phase	Dwell Periods Longer Than Cutoff (Seconds)				Hypothesized Cutoff* (Seconds)	Dwell Periods Shorter Than Cutoff (Seconds)				
0.00	1	4.00	1.50	0.75	0.45	0.30	0.30	0.20	0.14		
0.00	2		4.00	1.00	0.45	0.30	0.30	0.20	0.14	0.10	
0.27	1		4.00	1.50	0.75	0.57	0.45	0.30	0.20	0.14	
0.27	2			4.00	1.00	0.57	0.45	0.30	0.20	0.14	0.10
0.50	1		4.00	2.00	1.00	0.80	0.50	0.33	0.27	0.20	
0.50	2			4.00	1.00	0.80	0.45	0.30	0.20	0.14	0.10
1.00	1		12.00	4.00	2.00	1.30	1.25	0.75	0.50	0.33	
1.00	2				4.00	1.30	1.00	0.45	0.30	0.20	0.14 0.10
2.60	1		12.00	6.00	4.00	2.90	2.50	1.50	1.00	0.75	
2.60	2			12.00	4.00	2.90	2.00	1.25	0.75	0.50	0.33
5.00	1		25.00	12.00	6.00	5.30	4.00	3.00	2.00	1.00	
5.00	2				12.00	5.30	4.00	1.25	0.75	0.50	0.33
10.00	1		50.00	25.00	12.00	10.30	7.50	5.00	3.50	2.00	
10.00	2				12.00	10.30	6.00	4.00	2.50	1.50	1.00 0.75

* Transmission delay plus an average operator reaction time of 0.3 seconds

Table 6

Program Comparison: Phases 1 and 2

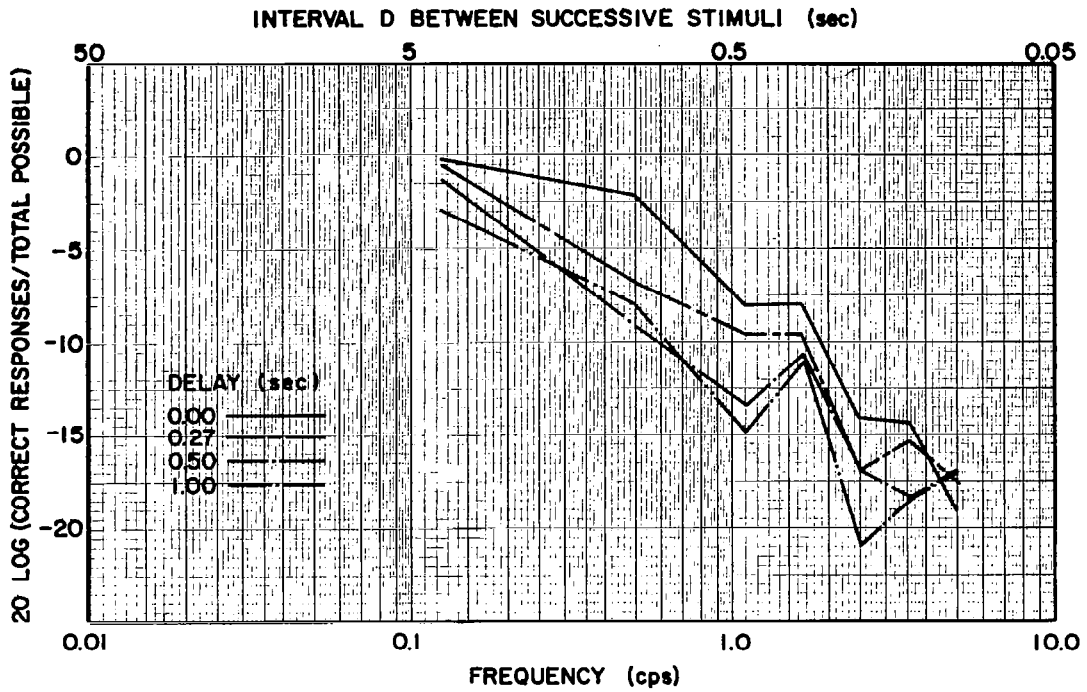
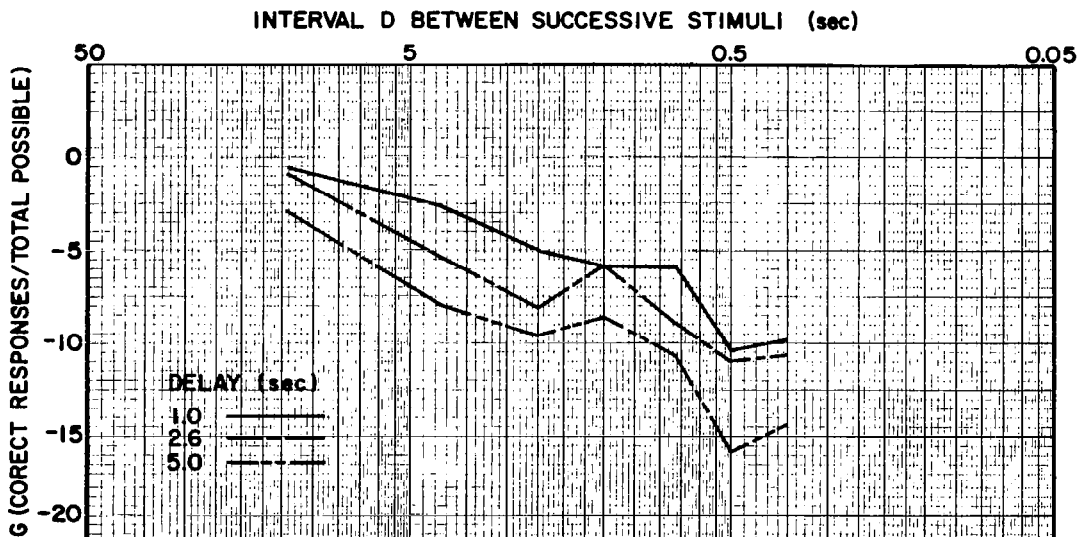

Figure 16 - Phase 2 Tracking Performance:
0.00 Second Program



deteriorate still further from the Phase 1 level. Phase 2 Tests are an example where there are both fewer periods longer than cutoff and more periods shorter than cutoff. The results shown in Figures 8 through 14, i.e., general performance falls off with increased complexity at any delay, seem reasonable in light of the above argument.

The Phase 2 Tests provided opportunity to observe the 0.00 Second Program at each of four delays and the 1.00 Second Program at each of three delays. Comparisons of these sets of results are shown in Figures 16 and 17 respectively. Both Figures show a general tracking performance degradation with increased delays. But it is difficult to make any claims as to the magnitude of the degradation because it appears to be a function of frequency of the input signal being tracked. Furthermore, there are specific frequencies at which performance seems to be enhanced by increases in delay; an example is 0.5 cps at 1.0 second delay in Figure 16. This dichotomy will be discussed in Section IV.

Figures 18 and 19 are plotted with data from Figures 16 and 17 respectively. They show the necessity of considering the range of frequencies (course complexity) of the input before trying to consider the magnitude of general performance degradation due to delay. This becomes evident by considering the effects of course frequency upon tracking performance in a system having a (i.e.) 0.50 second delay of visual feedback information.

If the frequency content of the path to be tracked is 0.125 cps, the tracking performance would be degraded by approximately 1.1 decibels or 11% (Figure 18) from tracking a comparable course without delay. If the frequency were increased to 0.50 cps, the performance degradation would be approximately 7.0 decibels or 55%, but if the course were made still more complex, i.e., 1.1 cps, the degradation would be only 4.5 decibels or 41%.

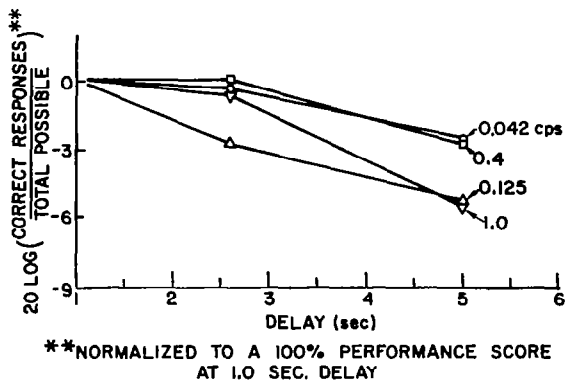

Figure 18 - Performance as a Function of Course Frequency and Delay (0.00, 0.27, 0.50, and 1.00 Sec.)

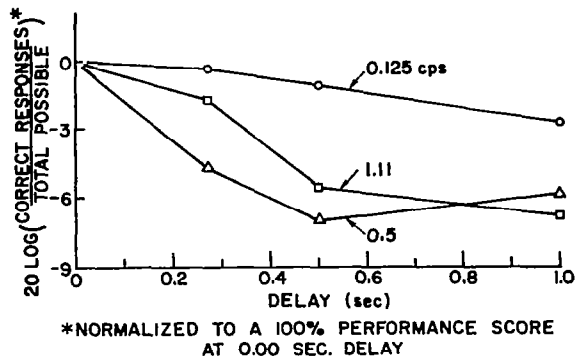

Figure 19 - Performance as a Function of Course Frequency and Delay (1.0, 2.6 and 5.0 Sec.)

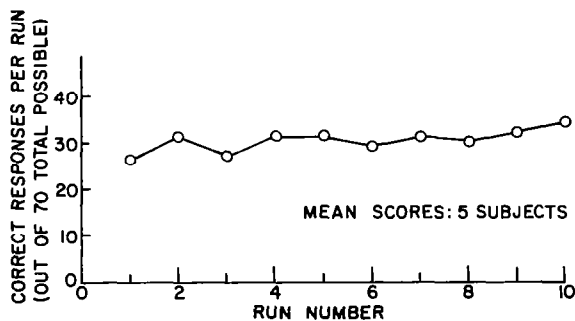

Figure 20 - Performance Improvement: Repeated Tracking of 0.5 Second Program with 0.5 Second Delay

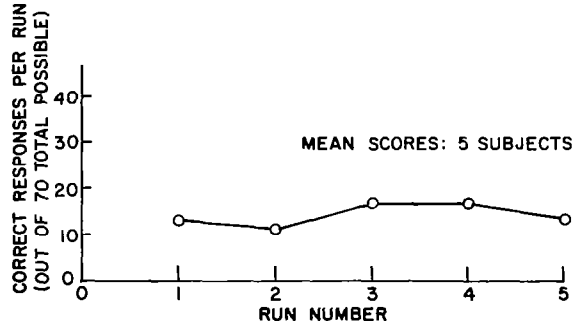

Figure 21 - Open-loop Performance: Repeated Tracking of 0.5 Second Program

It is apparent that course complexity is a major factor in arriving at quantitative statements regarding tracking performance with transmission-type visual feedback delays.

D. Learning Behavior (Phase 3)

Five subjects repeated the 0.5 Second Program 10 consecutive times under the conditions of a 0.5 second visual delay. For each run, each subject was presented 70 different light positions to track. Scoring was done on a basis of total correct responses per subject per run. Therefore, 70 would represent a perfect score for each of the runs. (This is a different basis than the one used for scoring Phases 1 and 2.)

The results (see Figure 20) show an upward trend in performance for all subjects. A straight line approximation of the mean performance versus run number has a positive slope of 0.60; it is significantly different from zero slope to a confidence level of 99%. The grand mean for the ten runs is 30.56 with a standard deviation of 2.48. By the nature of this test, it is difficult to separate "learning how to operate with 0.5 second delay" from "memorizing the 0.5 Second Program". It seems reasonable that with sufficient practice at running the same program, the subject could eventually memorize the program sufficiently well to make a high score without looking at the input.

E. Open-loop Performance (Phase 4)

The same five subjects involved in the Phase 3 Tests ran an additional five runs of the 0.5 Second Program (at 0.5 second delay), but this time without visual feedback. Just prior to the beginning of each run, the subject's control was adjusted to the center light (#6) position. After that, the subject performed as best he could and

relied only on proprioceptive and kinesthetic feedback. The results are shown in Figure 21. The grand mean for 25 runs is 14.5 or less than half the average of 30.6 which the same group realized on the Phase 3 Learning Tests. Not only is the mean tracking performance poorer when there is no visual feedback, the variability (as a percentage of the mean) is much greater:

	<u>Phase 3</u>	<u>Phase 4</u>
Grand Mean	30.56	14.48
Standard Deviation	2.48	2.46
As Percent of Mean	8.1%	17.0%

If one assumes normal distribution as a first approximation, 95% of the population of subjects would have a score of between 25.60 and 35.52 for each of the Phase 3 Tests and between 9.56 and 19.40 for each of the Phase 4. The latter fall into the region of random performance.

It seems safe to say that the subjects relied heavily upon visual feedback to achieve their high scores in Phase 3. These results also are a measure of the success of the design of the manual control system.

The latter was designed to minimize the paralleling effects of kinesthetic, tactile, and proprioceptive feedback (see "Equipment") so that the study would involve primarily visual feedback.

Test results, means, and standard deviations are shown in Appendix B.

Chapter IV

DISCUSSION OF RESULTS

A. General

The Phase 1 Tests show that performance deteriorates with increases in transmission-type delays. The Phase 2 Tests show that performance deteriorates with increases in course complexity. Quantitative cutoff frequencies for Phase 1 Tests (see Table 5) and comparable performance cutoff frequencies for Phase 2 Tests are shown in Table 7 and plotted in Figure 22.

Delay (Seconds)	Phase 1 Tests Cutoff Frequency (cps)	Phase 2 Tests Cutoff Frequency (cps)
0.00	0.78	0.56
0.27	0.33	0.22
0.50	0.18	0.17
1.00	0.14	0.13
2.60	0.066	0.072
5.00	0.050	0.043
10.00	0.028	---

Table 7

Measured Cutoff Frequencies: Phases 1 and 2

It is evident that as the delay increases beyond approximately 0.5 seconds, the cutoff frequency becomes progressively less affected by course complexity and becomes primarily a function of the transmission delay (T) alone. For delays larger than 1.0 seconds, the cutoff frequency (f_{c0}) for either the Phase 1 or Phase 2 Tests can be approximated by the following:

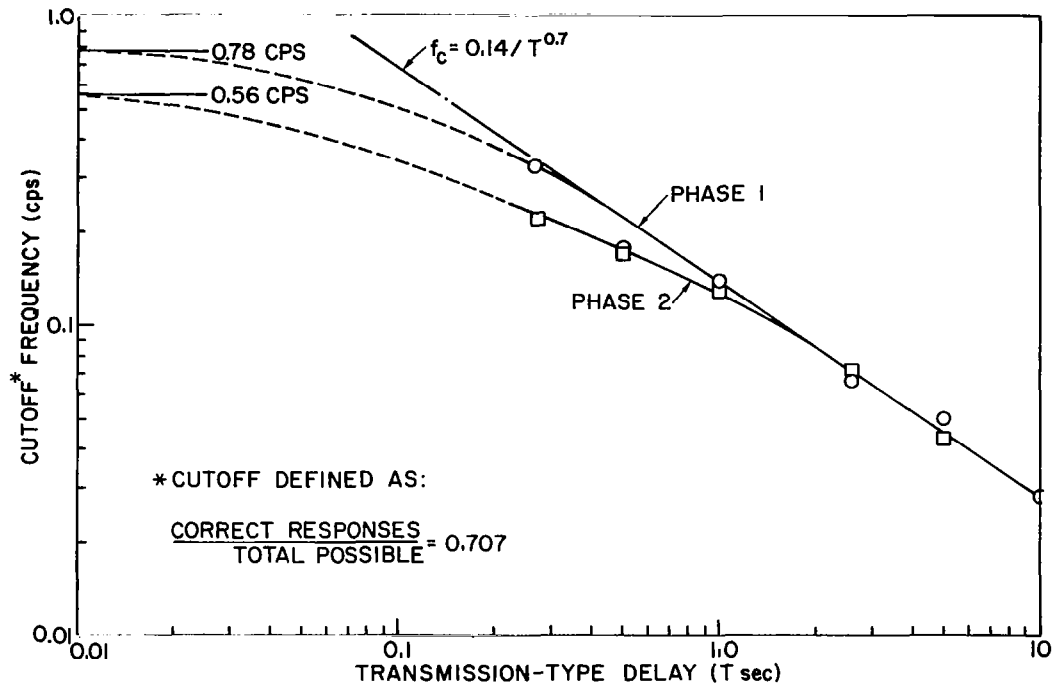

Figure 22 - Phases 1 and 2 Cutoff Frequency versus Delay

$$f_{co} = \frac{0.14}{T^{0.7}} \quad (3)$$

Where f_{co} = frequency (cps) at which tracking performance falls to 70.7% of a perfect score.

T = Transmission-type delay (seconds).

There is question as to the extent Equation 3 is applicable over a wide range of course complexities. The answer hinges upon the range of complexities of the courses associated with the Phases 1 and 2 Tests. Are they sufficiently different in complexity to represent a "wide range"?

Table 6 shows that the two courses associated with the 1.0 second delay represent the widest range tested at any of the delays. The measured cutoff frequencies for the 1.0 second delay tests are shown in Table 7. A comparison of the Phase 1 and 2 programs in respect to these cutoff frequencies is shown in Table 8.

Frequencies (cps) Tracked

	Phase 1	Phase 2
	0.04	0.13
	0.13	0.50
	0.25	1.11
	0.40	1.67
	0.67	2.50
	1.00	3.60
Measured Cutoff	1.50	5.00
(Table 7)	0.14	0.13

Table 8

Program Comparison: 1.00 Second Delay

Table 8 shows that both tests force the subject to respond predominately at a rate above the measured cutoff. The Phase 1 Course had only one point (.04 cps) appreciably below cutoff, and the Phase 2, none. The subjects' ability to calibrate themselves at the .04 cps point in the Phase 1 Test was noticeably good. Twenty-nine subjects correctly responded 94% of the time; see page 100 (Appendix B). Whereas for Phase 2, twenty-two subjects responded correctly to the lowest frequency (.13 cps) only 72% of the time; see page 107, Appendix B) So calibration on the lowest frequency (longest light dwell period) was superior for the Phase 1 Test.

Comparing the other end of the spectrum, for Phase 1, the subjects were required to track a frequency 10.7 times cutoff; for Phase 2, 38.4 times cutoff. For Phase 1, twenty-nine subjects successfully tracked the 1.5 cps input 32% of the time (p. 100); for Phase 2, twenty-two subjects tracked 5.0 cps only 14% of the time (p. 107).

It seems reasonable to conclude that Phases 1 and 2 Tests at 1.0 second delay represent a wide range of course complexities, yet Equation 3 appears to be a good approximation (within 10%) of the cutoff frequency for each. Equation 3 also should prove to be a good approximation for a wide range of course complexities at delays greater than 1.0 seconds. For frequencies lower than cutoff, operator tracking performance approaches a perfect score (ratio of correct responses to total possible equals 100%).

The Phase 3 (learning) and Phase 4 (open-loop) tests show the heavy reliance subjects place upon visual feedback of results of their previous control commands. It is evident that they operated the equipment as an intermittent closed-loop (man-machine) system. If typical closed-loop

characteristics prevail, then the over-all system response should show a degradation in performance at each of those frequencies where the transmission-type delay, the subject reaction time, and the phase lead or lag factors cause a phase reversal of the feedback information. With such a reversal, the subject would feel that he is responding correctly to the input when - actually - he would be out of phase with what he should be doing. Such reversals also should occur at every higher frequency that introduces an additional 360 degrees of phase shift; these are the harmonics of the lowest frequency at which 180 degree phase shift is introduced in the feedback loop.

Each of the graphs in Figures 8 through 14 were plotted with only seven points, so it is impossible to pick-off, with any reasonable accuracy, the frequency of each of the performance degradation troughs. Nonetheless, each of the graphs does show a trend for the performance to be fairly smooth from zero (cps) to the first trough and then go through a series of peaks and troughs at higher frequencies -- as is to be expected from a closed-loop analysis. The latter will be shown in conjunction with the development of a model.

B. Development of a Model

The Figure 1 block diagram can be redrawn as follows:

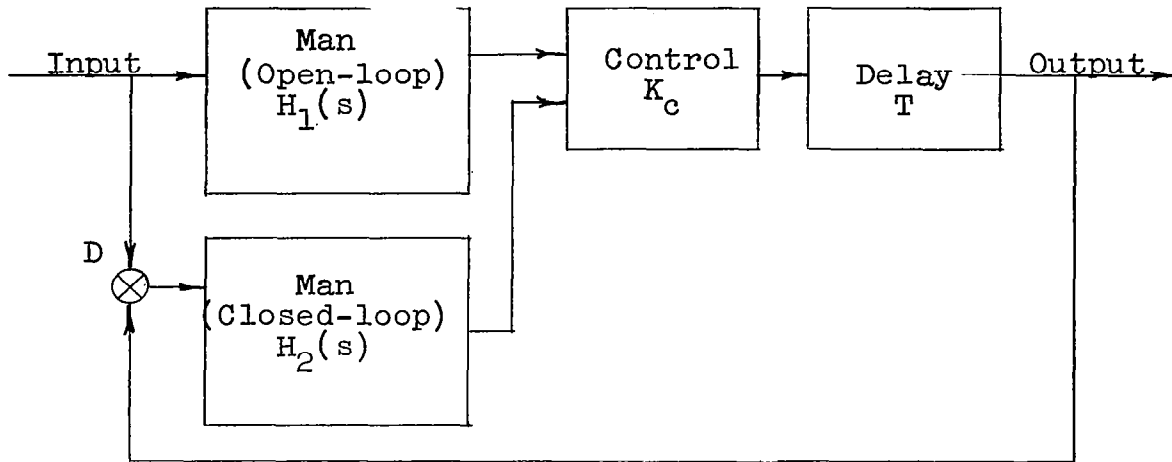

Figure 23

Expanded Block Diagram: Pursuit-Tracking

$H_1(s)$ is the transfer function (see Equation 2) of a subject operating open-loop, i.e., no feedback. $H_2(s)$ is the transfer function of the same subject operating closed-loop, i.e., with feedback. K_c is the transfer function of his manual control and can be assumed to have (in this case) a constant value for all frequencies. The delay (T) is the transmission-type delay. When the subject operates "open-loop", he performs without benefit of visual feedback, in this case, he would make control movements in response to the input alone. When he operates "closed-loop", he performs in response to the difference between the input and output; this difference is developed across the differential element D in Figure 23. A person, pursuit-tracking an input, switches his attention back and forth between "open-loop" and "closed-loop" response as he sees fit. This "switching" process obviously alters $H_1(s)$ and $H_2(s)$ accordingly.

$H_2(s)$ is within the closed-loop which includes the delay (T); $H_1(s)$ is presumably independent of T since it is part of an open-loop. It would be helpful to have quantitative information in regard to the way a subject shifts back and forth between $H_1(s)$ and $H_2(s)$. Unfortunately, this information is not available from either this research or the literature. $H_1(s)$ is a necessary part of any pursuit-tracking, but it is apparent from the Phase 4 Tests that it is secondary to the role of $H_2(s)$ in this study. Therefore, as an approximation, Figure 23 can be simplified to the following:

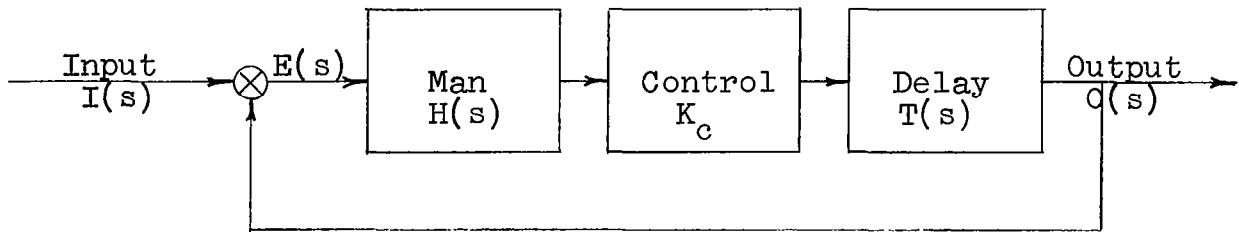

Figure 24

Simplified Block Diagram

In the above diagram, $H(s)$ is the open-loop transfer function of the human operator. In terms of a continuous model, this can be represented by Equation 2 but where the lead time-constant (T_L) and the lag time-constant (T_I) are both equal to zero. This action is justifiable on the grounds that the experimentation equipment was designed to eliminate (1) the possibility of successful anticipation ($T_L = 0$) by the operator and (2) the need for operator compensation ($T_I = 0$) for its dynamic characteristics. The simplified version of Equation 2 is shown as Equation 4.

$$H(s) = \frac{K_h e^{-rs}}{T_N s + 1} \quad (4)$$

Where $H(s)$ = Operator transfer function

K_h = Operator gain

T_N = Operator neuromuscular lag time-constant

r = Operator reaction time

$s = j2\pi f$ where j is a complex operator = $\sqrt{-1}$ and f is the input frequency in cps.

In Figure 24, the error signal is:

$$\begin{aligned} E(s) &= \text{Input} - \text{Output} \\ &= I(s) - O(s) \end{aligned}$$

The system transfer function is defined as $W(s)$ where the latter is:

$$W(s) = \frac{O(s)}{I(s)} = \frac{E(s) H(s) K_c T(s)}{I(s)}$$

and where

$$\begin{aligned} O(s) &= E(s) H(s) K_c T(s) \\ &= [I(s) - O(s)] H(s) K_c T(s) \\ &= K_c I(s) H(s) T(s) - K_c O(s) H(s) T(s) \end{aligned} \quad (5)$$

From Equation 5,

$$W(s) = \frac{O(s)}{I(s)} = \frac{K_c H(s) T(s)}{1 + K_c H(s) T(s)} \quad (6)$$

By substituting Equation 4 into 6 and by transforming $T(s)$ to its La Place equivalent of e^{-Ts} , Equation 6 becomes:

$$W(s) = \frac{\frac{K_c K_h e^{-rs} e^{-Ts}}{T_N s + 1}}{1 + \frac{K_c K_h e^{-rs} e^{-Ts}}{T_N s + 1}}$$

And combining terms and simplifying,

$$W(s) = \frac{K}{e^{\tau s} (T_N s + 1) + K} \quad (7)$$

Where $K = K_c K_h =$ System gain

and $\tau = r + T =$ System delay

Since $e^{\tau s}$ can be expanded into its real and imaginary components where

$$e^{\tau s} = \cos \omega \tau + j \sin \omega \tau$$

and $\omega = \text{frequency expressed in radians} = 2\pi f$

Equation 7 can be rewritten as

$$W(s) = \frac{K}{\cos \omega \tau - \omega T_N \sin \omega \tau + K + j(\omega T_N \cos \omega \tau + \sin \omega \tau)} \quad (8)$$

Equation 8 was programmed on a computer for each of the transmission delays (T) and with a series of values for K, T_N , and r. The objective was to find a combination of quasi-linear values for each delay that would cause Equation 8 to describe the experimentally determined performances (Figures 8 - 14) up to the respective cutoff frequencies. Table 9 shows the values of K and T_N that seemed to provide the best-fit.

Delay T (Seconds)	System Delay* τ (Seconds)	System Gain K	Neuromuscular Lag T_N (Seconds)
0.00	0.30	0.50	0.45
0.27	0.57	0.70	0.45
0.50	0.80	0.70	0.45
1.00	1.30	0.60	0.45
2.60	2.90	0.50	0.45
5.00	5.30	0.40	0.45
10.00	10.30	0.40	0.45

*Based upon human reaction time delay of 0.3 seconds which was typical

Table 9

Best-Fit Values for Mathematical Model

C. Comparison of Experiment and Model

Curves for Equation 8, with values from Table 9, are shown in Figure 25. The plot is made to a horizontal scale that is identical to that used for Figures 8 through 17. The vertical scale is plotted on the basis of "20 log of the performance ratio" just as for Figures 8 - 17, but the criteria for establishing the performance ratio is not the same. For the mathematical model, the plot is based upon the ratio of output amplitude $O(s)$ to input amplitude $I(s)$; for Figures 8 - 17, the graphs are based upon the ratio of the correct responses to the total possible correct responses (at a given frequency). For either criteria, a perfect score is represented by a performance ratio of unity; this appears as a value of "0" on the ordinate axis. In the case of scoring of subject performance for the Phases 1 and 2 Tests, performance degradation necessarily appears as a negative value. For the model, performance (compared to a perfect score of $\frac{O(s)}{I(s)} = 1$) can have either a positive or a negative value depending upon the constants and the frequency. If cutoff for the mathematical model is defined as that frequency where the performance departs from a perfect score by 3 decibels ($20 \log .707$ or $20 \log 1.414$), the cutoff frequency comparison for the model and the experiment is as shown in Table 10 and Figure 26.

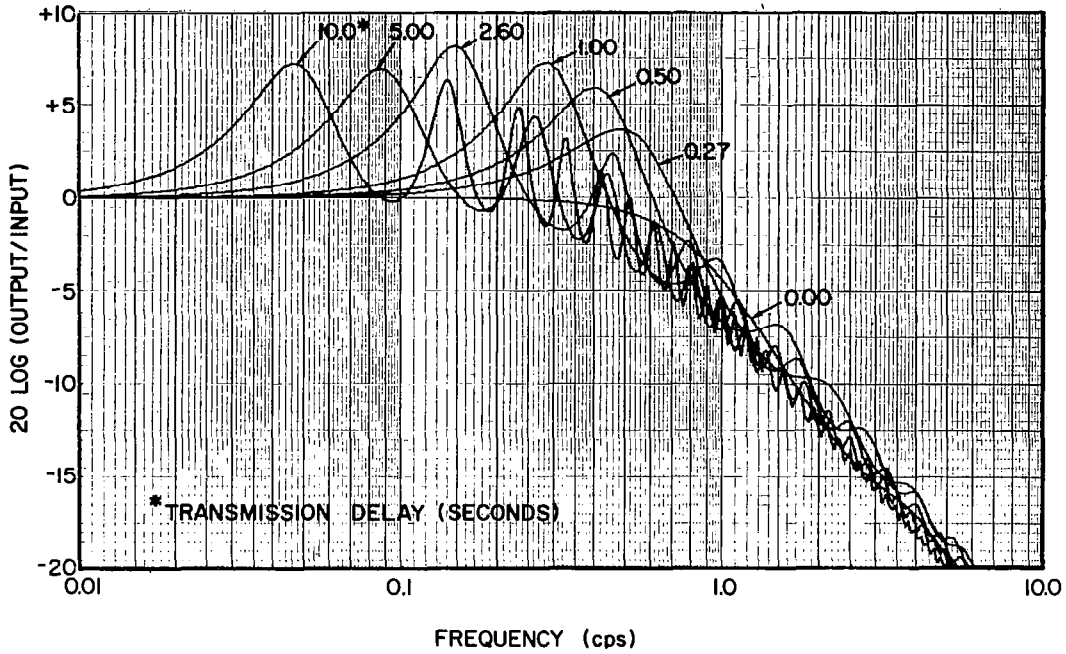

Figure 25 - Quasi-Linear Mathematical Model Performance

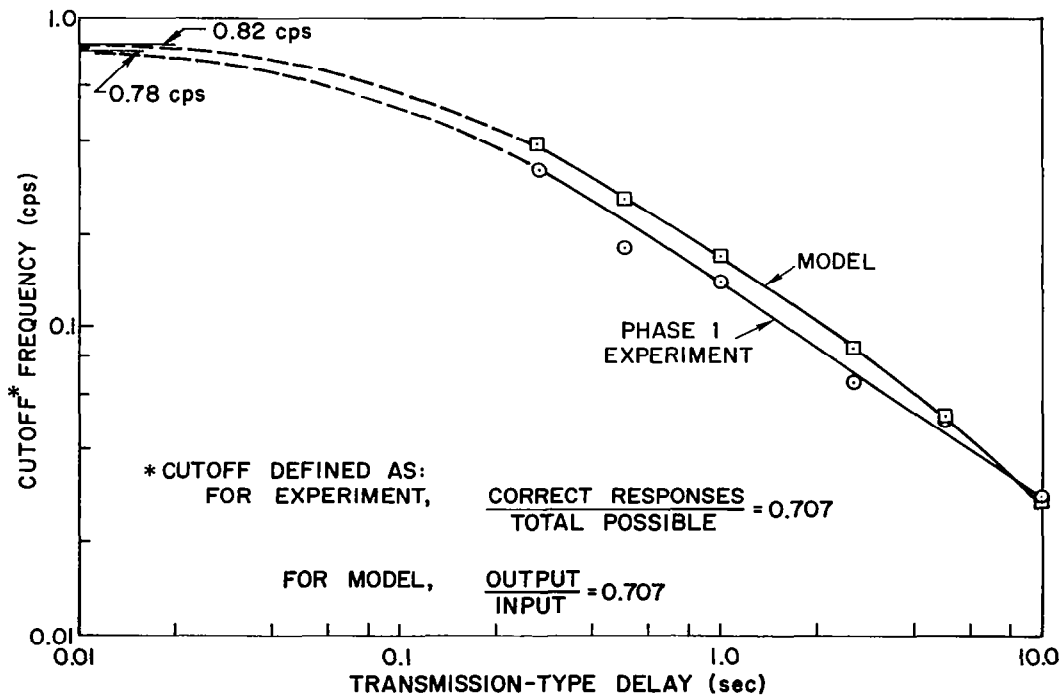

Figure 26 - Phase 1 and Mathematical Model Cutoff Frequency versus Delay

Delay (Seconds)	Mathematical Model Cutoff Frequency (cps)*	Phase 1 Tests Cutoff Frequency (cps)**
0.00	0.82	0.78
0.27	0.39	0.33
0.50	0.26	0.18
1.00	0.17	0.14
2.60	0.085	0.066
5.00	0.051	0.050
10.00	0.027	0.028

* From Figure 25

** From Table 7

Table 10

Cutoff Frequency Comparison: Model and Experiment

For both the model and the experiment, as the frequency to be tracked is reduced below the cutoff frequency, the performance approaches a perfect score.

The quasi-linear mathematical model did not approximate the experimentally determined cutoff frequencies as closely as had been hoped; nevertheless, the model helps explain the general shape, and some of the characteristics of the operator tracking performance curves shown in Figures 8 - 17. For the case of zero transmission delay, $e^{\tau s}$ in Equation 7 can be approximated by unity; therefore, for zero delay,

$$W(s) \approx \frac{K}{T_N s + 1 + K} \quad (9)$$

For very low frequencies,

$$W(s) \approx \frac{K}{1 + K}$$

and for very high frequencies

$$W(s) \approx \frac{K}{T_N s}$$

The break point frequency (f) between the two extremes is at

$$f = \frac{1 + K}{2\pi T_N} \quad (10)$$

Substituting values from Table 9 (0.00 Delay) into Equation 9, the breakpoint frequency becomes $f = 0.53$ cps. Below this frequency the tracking performance ideally is perfect, and above, the tracking performance falls off proportional to $\frac{1}{f}$ or 6 decibels per octave. Figure 27 shows Equation 9 plotted for the zero second values; it has been normalized so the low frequency response appears at a level of 0(db) . Figure 27 also shows a comparison of the results from Phases 1 and 2 experimentation and the quasi-linear model, Equation 8. It is apparent that:

- (1) The Model (Equation 8) is a reasonable representation of the actual performance and
- (2) The performance ratio beyond cutoff is proportional to $\frac{1}{f}$ as one would expect.

For cases with transmission-type delays, Figure 25 shows that performance for any delay eventually falls along the same 6 db/octave slope that occurs with zero second delay. But up to the breakpoint frequency associated with the latter slope, the response remains within a spread of less than 10 decibels regardless of the number of octaves between the cutoff frequency, for a given delay, and the breakpoint. For 10 second delay, there is a spread of over four octaves between the cutoff frequency of 0.028 cps and the breakpoint frequency of 0.53 cps. Between these limits there is a series of peak and troughs of

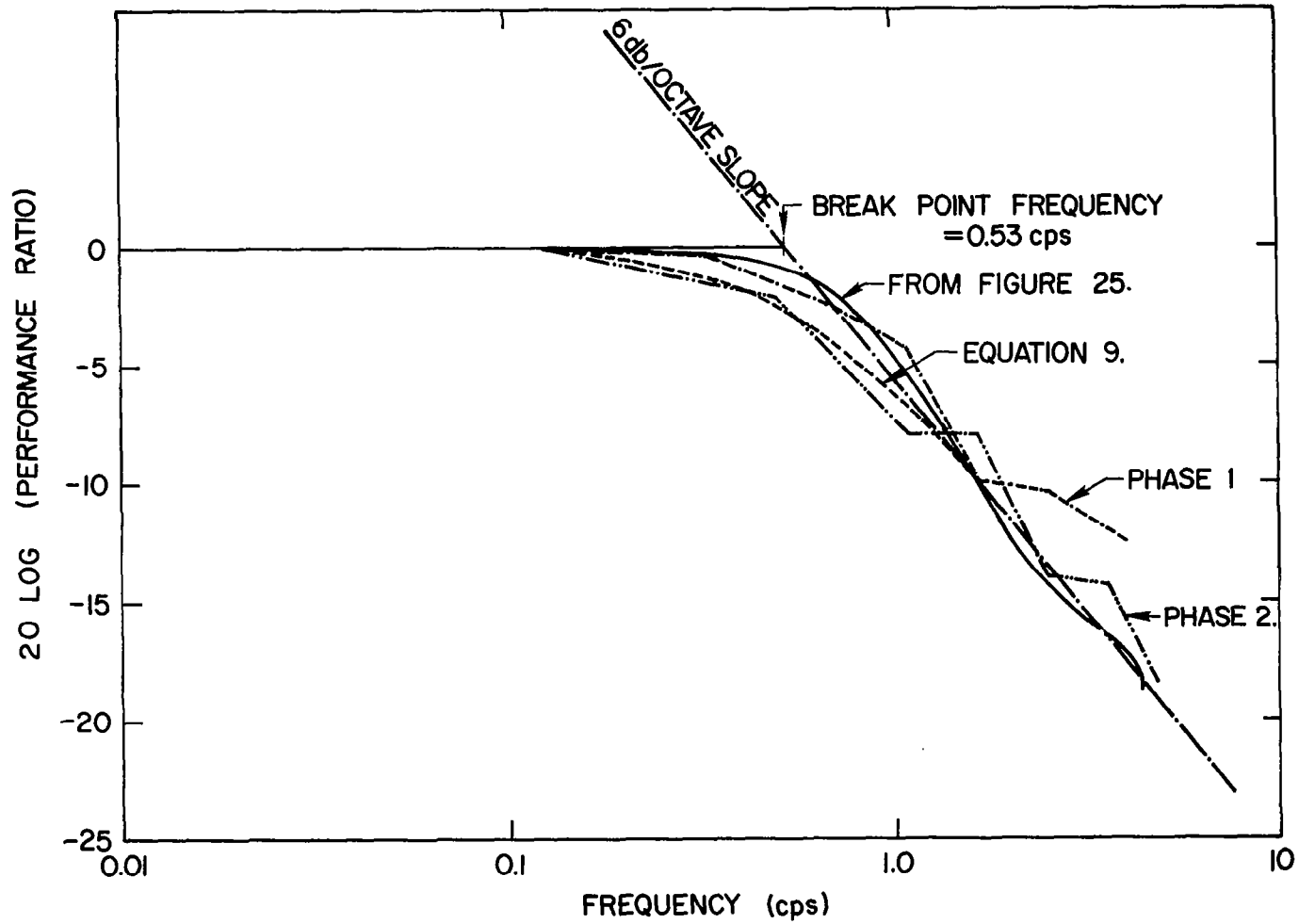

Figure 27 - Zero-Second-Delay Performance: Model and Experiment

amplitudes that are caused, primarily, by the alternate 180 degree shifts of phase introduced in the feedback loop by the transmission and operator reaction time delays (see Equations 7 and 8). These same characteristics are prevalent in the experimental test results: Figure 8 has a slope beyond cutoff (-3 ordinate value) that is proportional to $\frac{1}{f}$ (see Figure 27). Figure 9 has a lesser slope and the slopes become progressively less as the delay is increased. The effect is most apparent in the composite graphs of the Phase 1 Tests shown in Figure 15. The peaks and troughs are also apparent, but not to the extent indicated in the mathematical model plot of Figure 25. This difference may be explainable on the grounds that the experimental results are the mean of a minimum of 23 subjects, therefore, individual peaks and troughs tend to be averaged out. But seems equally plausible that the operators being very adaptable, adjust their gain when they are confronted with improper feedback information. The latter needs further study.

The quasi-linear mathematical model also helps explain what appears to be an improvement in tracking performance, at a given frequency, by the introduction of additional delay in the feedback loop. Figure 25 shows the phenomenon. It is a direct result of the peaks and troughs that occur beyond the cutoff point for any given delay: an example is at 0.09 cps where performance is better with 10 second delay than with either 5.0 or 2.6 second delays. It is obvious that such an improvement is highly sensitive to frequency and is possible only if the operator is forced to operate beyond the point of normal system cutoff for the given delay.

D. Comparison of Results to Hypotheses

Hypothesis Number 1: Under conditions of zero transmission delay, an operator pursuit-tracking a wide-band input has an upper cutoff frequency of approximately 1 cycle per second.

This research showed that operator tracking performance is excellent for low frequencies and has a smooth response degradation curve to a high frequency cutoff of approximately 0.56 to 0.78 cps depending upon the course complexity. In the Phase 1 Tests, the operators were force-paced to a high frequency limit of 3.6 cps; their high frequency performance cutoff frequency (correct responses equal to 0.707 of total possible) was 0.78 cps. For the Phase 2 Tests, the operators were force-paced to a high frequency limit of 5.0 cps; their high frequency performance cutoff frequency decreased to 0.56 cps. It is reasonable that the high frequency cutoff point is inversely related to the highest forcing frequency. The operator tends to sacrifice his score on lower frequencies in order to hit more of the higher frequency inputs. If the input frequency band width had been lowered to, say, 2 cps, the cutoff frequency probably would approach more closely 1 cps. The results seem to be in line with the research of both Elkind²³ and Vince⁷⁰.

Hypothesis Number 2: Under conditions of T seconds of transmission-type delay, an operator's upper cutoff frequency (f_c) is controlled by a move-and-wait strategy limitation; this frequency is equal to the inverse of twice the move-and-wait period (τ), or:

$$f_c = \frac{1}{2\tau}$$

where τ = Transmission delay (T) plus operator reaction time (r).

This research showed the cutoff frequency for delays of 0 to 10 seconds to be lower than that hypothesized. The comparison is as follows:

Hypothesized:

$$f_c = \frac{1}{2\tau} = \frac{0.5}{\tau} \approx \frac{0.5}{T} \text{ for } T \gg r$$

Actual:

$$f_{co} \approx \frac{0.14}{T^{0.7}} \quad \text{for } T \gg r$$

The hypothesized cutoff frequency was very nearly the same as the lowest frequency at which 180° phase shift occurred in the feedback loop. At the hypothesized cutoff frequency for each of the delays, the ratio of correct responses to total possible is more on the order of 0.4 to 0.5 rather than the 0.7 value arbitrarily established for determining the "actual" cutoff frequency for each delay.

Hypothesis Number 3: Tracking performance at frequencies below cutoff is reasonably predictable.

For all delays tested between the limits of 0 and 10 seconds, the performance plots were smooth over a range of a very low frequency to the cutoff frequency.

For the type of tracking tested, there is good reason to believe that the cutoff frequency is reasonably predictable by Equation 3 for all delays that are large in respect to an operator's reaction time and that his tracking performance from zero cps to that cutoff frequency will be reasonably smooth curve.

Chapter V

CONCLUSIONS

A. General

This thesis was aimed at studying the effects of time delay in the visual feedback loop of a man-machine system. A one-dimensional, step-type input, pursuit tracking experiment was developed to study these effects with transmission-type delays of 0 to 10 seconds. Thirty-six subjects participated in a series of tests that covered: seven different delays, two different levels of course complexity for each delay, learning, and open-loop performance. The following conclusions were reached from the research:

1. Performance deteriorates non-linearly with increases in delay.
2. Performance degradation is also a function of course complexity and, in general, the degradation is greater with increased course complexity.
3. For step-type inputs, a one-dimensional tracking system has a cutoff frequency,

$$f_{co} \approx \frac{0.14}{T^{0.7}} \text{ (cps)}$$

for all delays (T) much greater than the operator reaction time and for all course complexities studied.

4. A plot of tracking performance versus frequency is a reasonably smooth and predictable curve for all frequencies up to the cutoff frequency.

5. A plot of tracking performance over a range of frequencies higher than the cutoff frequency exhibits a series of peak and troughs due to phase shift in the feedback loop.
6. Tracking performance up to the cutoff frequency (f_{co}) can be described reasonably well by the quasi-linear mathematical model:

$$W(s) = \frac{K}{e^{\tau s}(T_N s + 1) + K}$$

where the system gain (K) and the neuromuscular time lag (T_N) are a function of the system delay (τ).

7. Human operators tend to place heavy reliance upon proprioceptive feedback to minimize the frustrations caused by long transmission delays of their visual feedback information; they seem to follow this practice even when the result is to further impair their tracking performance.

B. Design Considerations

Human operator tracking capability obviously is of prime importance to design engineers of man-machine tracking systems whether or not such systems involve transmission-type time delays. It is imperative that the engineer know the reasonable performance limits of the operator in order to prevent designing a system that approaches (or exceeds) safe limits of operational stability. The need for this knowledge becomes increasingly important as the speed of the system operation (i.e., the frequency to be tracked) increases and/or the time delay due to transmission of either control or feedback information becomes greater.

This Thesis has shown that the system cutoff frequency is highly dependent upon the delay in the system. Even small transmission delays such as those which approximate the operator's reaction time delay lower the cutoff frequency by a factor of over two.

For a system which requires its operator to respond reliably to a non-periodic input having a rate as high as 1 cycle per second and not involving a transmission delay, the designer should concern himself with the following:

1. Variations in the operator's reaction time.
2. Possibility of "play" or "slip" in the mechanism that might introduce an unwanted transmission-type delay.
3. Possibility of eliminating high frequency (over 1 cps) input information that may add to the complexity and deleteriously affect the operator's tracking performance at rates up to 1 cycle per second.

In some systems, transmission-type time delays are inevitable. Typically, these are ones in which there is a radio communications link between the controller and that which is being controlled. In cases where the operator must respond with a series of non-periodic, discrete movements and where there is a transmission delay which is long with respect to the operator's reaction time delay, the designer should concern himself with:

1. The system upper cutoff frequency which is approximately

$$f_{co} = \frac{0.14}{T^{0.7}} \text{ (cps) } .$$

2. Problems of tracking performance beyond this cutoff frequency. (This performance goes through a series of peaks and troughs that have questionable amplitude predictability)
3. Possibilities of the operator placing undue reliance upon his proprioceptive (and other) feedback information from his control in preference to utilizing the more significant, delayed, visual feedback.

C. Recommendations for Future Work

During the period of study and research pertaining to this Thesis, five other major areas were considered that seemed related directly to a study of the "effects of time delay in the visual feedback loop of a man-machine system". In each case, further study was delayed. These areas needing to be researched are:

1. Sensory interaction between proprioceptive feedback (and other non-delayed sensory inputs) and delayed visual feedback.

2. The effects of lead and/or lag networks in the feedback loop of a system in which there is delayed visual feedback.
3. The adaptive behavior of an operator in adjusting his gain factor when confronted with phase reversals in the visual feedback information.
4. The adaptive behavior of an operator in shifting his attention (and his gain) back and forth between the input signal, the delayed output signal, and the difference between the two, when engaged in a pursuit-tracking task.
5. Tracking performance differences between man-machine system incorporating delayed visual feedback but having:
 - (a) continuous-type and
 - (b) step-type inputs.

Sensory Interaction

The usual information channel delays to which man is accustomed, the "reaction time" between the actual stimulus and the perceived stimulus, are substantially the same for his primary information channels and are seldom troublesome. Under conditions of significant delay in the visual loop, and no delay in the proprioceptive loop, interference may develop in the same way as found for auditory delays by Fairbanks²⁶, Kalmus, Fry, and Denes⁴⁰, and Bergiejk and David¹³. There very well could be a particular delay where the deleterious effects of the delay reach a maximum. In a tracking task in which there is visual delay, the interference may occur between the visual channel and the tactual, kinesthetic, and/or proprioceptive channels; the latter is ubiquitous, so some interference is inescapable.

Lead and Lag Networks

The effects of these networks have been studied extensively for conditions of no-delay and exponential lag. But there is reason to question the applicability of this information to cases which include transmission-type delay. In the latter type system, the error signal is necessarily a function of the operator's control commands. Therefore, if he responds at a higher rate than the normal system cutoff frequency (see Equation 3), he will cause the error signal he will see one delay period later to have a rate beyond his cutoff frequency. It seems reasonable to hypothesize that the overall system performance can be improved by incorporating a lag network in the loop, but that still better performance can be realized by using a combination of lead and lag networks.

Adaptive Behavior

Man is often confronted with the problem of controlling a machine where the system tends to be unstable. In such cases he has the ability to adjust his own actions so as to either bring the system into a stable mode (if it were not so) or prevent it from becoming oscillatory. Undoubtedly he can exercise this same type of ability to remotely control a machine through a visual time delay. To what extent he does and to what extent he is consistent in operating beyond the normal system cutoff frequency needs further study.

It is recognized that man can track high frequency inputs better with pursuit than compensatory type tracking techniques. Yet very little is known about the mathematical model of an operator who is engaged in pursuit tracking. The reason for lack of knowledge is that so little is

known about the way the operator shifts between his open-loop performance and his closed-loop performance in his tracking task. This problem was evident in the development of the model in Section IV B.

Continuous-type and Step-type Inputs

The present research was concerned with step-type inputs. At the beginning of the study, there was a serious question as to whether continuous-type or step-type inputs should be employed. There was never any doubt that it was important to study both -- but only one at a time. The latter was selected for reasons covered in Section II A. A reasonable hypothesis is that the overall system performance with either type of input is comparable and that the same quasi-linear mathematical model is applicable to each.

LIST OF REFERENCES

1. Adams, J. A., "Human Tracking Behavior", Psychological Bulletin, Vol. 58, No. 1, pp. 55-79, January 1961.
2. Adams, J. A. and Webber, Carl E., "Monte Carlo Model of Tracking Behavior", Human Factors, pp. 81-102, February 1963.
3. Adams, J. A., "A Simplified Method for Measuring Human Transfer Functions", NASA TN D-1782, 1963.
4. Adams, J. L., "An Investigation of the Effects of the Time Lag Due to Long Transmission Distances Upon Remote Control, Phase I Tracking Experiments", NASA Tech. Note D-1211, 1961.
5. Adams, J. L., "An Investigation of the Effects of the Time Lag Due to Long Transmission Distances Upon Remote Control, Phase II Vehicle Experiments, Phase III Conclusions", NASA Tech. Note D-1351, 1962.
6. Adams, J. L., Remote Control with Long Transmission Delays, Doctoral Dissertation, Stanford University, 1961.
7. Andreas, B. G., Green, R. F., and Spragg, S. D. S., "Transfer Effects between Performance on a Following Tracking Task and a Compensatory Tracking Test", Journal of Psychology, Vol. 37, pp. 173-183, 1954.
8. Arnold, J. E., and Braisted, P. W., "Design and Evaluation of a Predictor for Remote Control Systems with Signal Transmission Delays", NASA Tech. Note D-2229, 1963.
9. Bekey, G. A., "Sampled Data Models of the Human Operator in a Control System", ASD TDR 62-36, February 1962.
10. Bekey, G. A., "The Human as a Sampled-data System", IRE Trans. PGHFE, September 1962.
11. Belanger, Pierre R., "Time-Varying Characteristics of the Human Operator in an Open Loop", Dynamic Analysis and Control Lab, Mass. Inst. of Tech., Cambridge, AD - 275 774.
12. Bellman, R., and Kalaba, R., "On Adaptive Control Processes", IRE Transactions on Automatic Control, Vol. AC-4 No. 2, November 1959.
13. Bergeijk, W. A. Van, and David, E. E., Jr., "Delayed Hand-writing", Percept. Motor Skills, pp. 347-357, September 1959.

14. Birmingham, H. P., "Optimization of Man-Machine Control Systems", IRE-Wescon Conv. Record, Part 4, 1958.
15. Birmingham, H. P., and Taylor, F. V., "A Design Philosophy for Man-Machine Control Systems", Proceedings of the IRE, Vol. XLIII, No. 12, 1954. Reproduced in Selected Papers on Human Factors in the Design and Use of Control Systems, Edited by H. Wallace Sinaiko, 1961.
16. Braisted, P. W., Study of a Predictor for Remote Control Systems Operating with Signal Transmission Delays, Doctoral Dissertation, Stanford University, 1963.
17. Chomet, M., Freeberg, N., and Swanson, A., "A Simulation of Operator Capability in Robot Vehicle Control", IRE International Convention Record, Part 9, 1962.
18. Chubb, Gerald P., "An Evaluation of Proposed Applications of Remote Handling in Space", Technical Report for 1954-1964, Aerospace Medical Research Labs, Wright-Patterson AFB, Ohio, October 1964.
19. Conklin, J. E., "Effects of Control Lag on Performance in a Tracking Task", Journal of Experimental Psychology, Vol. 53 No. 4, pp. 261-268, April 1957.
20. Craik, K. J. W., "Theory of the Human Operator in Control Systems, I. The Operator as an Engineering System", British Journal of Psychology, Vol. 38, pp. 56-61, 1947.
21. Craik, K. J. W., "Theory of the Human Operator in Control Systems, II. Man as an Element in a Control System", British Journal of Psychology, Vol. 38, pp. 142-148, 1948.
22. Diamantides, N. D., "Man as a Link in a Control Loop", Electro-Technology, January 1962.
23. Elkind, J. I., "Characteristics of Simple Manual Control Systems", MIT Lincoln Laboratory TR No. 111, April 1956.
24. Elkind, J. I., and Forgie, C. D., "Characteristics of the Human Operator in Simple Manual Control Systems", IRE Transactions on Automatic Control, Vol. AC-4, No. 1, pp. 44-55, May 1959.
25. Elkind, J. I., Starr, E. A., Green, D. M., and Darley, D. L., "Evaluation of a Technique for Determining Time-Invariant and Time-Variant Dynamic Characteristics of Human Pilots", NASA Tech. Note D-1897, May 1963.

26. Fairbanks, G., "Selective Vocal Effects of Delayed Auditory Feedback", Journal, Speech Hearing Dis., Vol. 20, pp. 333-346, 1955.
27. Ferrell, W. R., "Remote Manipulation with Transmission Delay", MIT Report DSR 9991-1, September 1964.
28. Ferrell, W. R., "Remote Manipulation with Transmission Delay", Sixth Annual Symposium of IEEE, PGHF, May 1965.
29. Fitts, P. M., "The Information Capacity of the Human Motor System in Controlling the Amplitude of Movement", Journal of Experimental Psychology, Vol. 47, pp. 381-391, 1954.
30. Fitts, P. M., and Peterson, J. R., "Information Capacity of Discrete Motor Responses", Journal of Experimental Psychology, Vol. 67, pp. 103-112, 1964.
31. Fogel, L. J., Biotechnology: Concepts and Applications, Prentice-Hall, 1963.
32. Fox, G. J., "Perceptual-Motor Factors in the Remote Control of a Lunar Vehicle, Phase 1: The Effects of a Communication Time Delay on Steering Performance as a Function of Vehicle Speed and Course Complexity", Grumman Aircraft Report No. ADR09-07061.1, 1962.
33. Freed, A. M., "Measuring Human Interaction in Man-Machine Systems", IRE-Wescon Conv. Record, Part 4, p. 189, 1960.
34. Gregg, L. T., "A Logical Model of Logical Man", Sixth Annual Symposium of IEEE PGHF, May 1965.
35. Hansen, Walter, "An Investigation of the Tracking Capability of a Human Pilot", Master's Thesis, Arizona University, June 1964.
36. Hick, W. E., "The Discontinuous Functioning of the Human Operator in Pursuit Tasks", Quarterly Journal of Experimental Psychology, Vol. 1, pp. 36-51, 1948.
37. Howell, W. C., and Griggs, G. E., "Information Input and Processing Variables in Man-Machine Systems: A Review of the Literature", Technical Report: NAVTRADEVCEM 508 - 1, U. S. Naval Training Device Center, October 1959.
38. Jackson, A. S., "Synthesis of a Linear Quasi Transfer Function for the Operator in Man-Machine Systems", IRE Wescon Convention Record, Part 4, pp. 263-272, 1958.

39. Kalmus, H., Denes, P. and Fry, D. B., "Effect of Delayed Accoustic Feedback on Some Non-Vocal Activities", Nature, Vol. 175, p. 1078, 1955.
40. Kalmus, H., Fry, D. B. and Denes, P., "Effects of Delayed Visual Control on Writing, Drawing, and Tracing", Language and Speech, Vol. 3, pp. 96-108, 1960.
41. Kelley, Charles R., Mitchell, M., "Manual Control Theory and Applications", Dunlap and Associates, Inc.
42. Krendel, E. S., and McRuer, D. T., "Dynamic Responses of the Human Operator", USAFWADC TR 56-524, October 1957.
43. Levine, M., "Transfer of Tracking Performance as a Function of a Delay Between the Control and the Display", USAF WADC TR 53-237, November 1953.
44. Levine, M., Senders, J. W., Morgan, R. L., and Doxtater, L., "Tracking Performance as a Function of Exponential Delay and Learning, Final Report", Aerospace Medical Research Labs, Wright-Patterson AFB, Ohio, November 1964.
45. Licklider, J. C. R., "Quasi-linear Operator Models in the Study of Manual Tracking", in Developments in Mathematical Psychology, R. D. Luce, Editor, Free Press, Glencoe, Illinois, 1960.
46. Licklider, J. C. R., "Man-Computer Symbiosis", IRE Trans. PGHFE, p. 4, March 1960.
47. Mayne, R., "Some Engineering Aspects of the Mechanism of Body Control", Electrical Engineering, Vol. 70, pp. 207-212, March 1951.
48. Morgan, C. T., Cook, J. S., Chapanis, A. and Lund, M. W., Human Engineering Guide to Equipment Design, McGraw-Hill, 1963.
49. Noble, M. E., Fitts, P. M. and Warren, E. E., "The Frequency Response of the Skilled Subjects in a Pursuit Tracking Task", Journal of Experimental Psychology, Vol. 49, pp. 249-256, 1955.
50. North, J. D., "The Human Transfer Function in Servo Systems, Automatic and Manual Control, A. Tustin, Ed., Academic Press, New York, 1952.
51. Overmyer, R. F., "Is Man Necessary?", Electrical Engineering, 1962.

52. Phillips, R. S., "Manual Tracking" in Theory of Servomechanisms, Edited by H. M. James, N. B. Nichols, and R. S. Phillips, McGraw-Hill, New York, pp. 360-368, 1947.
53. Pierce, J. R., Symbols, Signals, and Noise: The Nature and Process of Communication, Harper and Brothers, 1961.
54. Ragazzini, J. R. and Franklin, G., Sampled-Data Control Systems, McGraw-Hill Book Co., Inc., New York, 1958.
55. Regan, J. J., "Tracking Performance Related to Display Control Configurations", Technical Report: NAVTRADEVEN 322-1-2, U. S. Naval Training Device Center, January 1959.
56. Rockway, M. R., "The Effect of Variations in Control-Display Ratio and Exponential Time Delay on Tracking Performance", USAF WADC TR 54-618, December 1954.
57. Roig, R. W., "A Comparison Between Human Operator and Optimum Linear Controller RMS-Error Performance", IRE Trans. on Human Factors in Electronics, Vol. HFE-3 No. 1, March 1962.
58. Saunders, A., "High Frequency Response with Delay" (unpublished paper), Stanford University, 1965.
59. Senders, J. W., and Cruzen, M., "Tracking Performance on Combined Compensatory and Pursuit Tasks", USAF WADC TR 52-39, 1952.
60. Senders, J. W., The Influence of Surround on Tracking Performance: 1. Tracking on Combined Pursuit and Compensatory One-Dimensional Tasks with and without a Structured Surround, USAF WADC TR 52-229, February 1953.
61. Senders, J. W., "Survey of Human Dynamics Data and a Sample Application", USAF WADC TR 59-712, November 1959.
62. Sheridan, T. B., and Ferrell, W. R., "Remote Manipulative Control with Transmission Delay", IEEE Trans. on Human Factors in Electronics, 1963.
63. Sheridan, T. B., "Three Models of Preview Control", Sixth Annual Symposium of IEEE PGHF, May 1965.
64. Smith, W. M., McCrary, J. W., and Smith, K. U., "Delayed Visual Feed-back and Behavior", Science, Vol. 132, pp. 1013-1014, 1960.
65. Smith, Karl U., Delayed Sensory Feedback and Behavior, Saunders Company, 1962.

66. Teper, G. L., and Jex, H. R., "Synthesis of Manned Booster Control Systems Using Mathematical Pilot Models", Sixth Annual Symposium of IEEE PGHF, May 1965.
67. Telford, D. N., "Refractory Phase of Voluntary and Associative Responses", Journal of Experimental Psychology, Vol. 14, pp. 1-35, 1931.
68. Tustin, A., "The Nature of the Operator's Response in Manual Control, and its Implications for Controller Design", Journal Electrical Engineers, Vol. 94, IIA, pp. 190-203, 1947.
69. Vince, M. A., "The Intermittency of Control Movements and the Psychological Refractory Period", British Journal of Psychology, Vol. 38, pp. 149-157, 1948.
70. Vince, M. A., "Rapid Response Sequences and the Psychological Refractory Period", British Journal of Psychology, Vol. 40, pp. 23-40, 1949.
71. Vince, M. A., "Corrective Movements in a Pursuit Task", Quarterly Journal of Experimental Psychology, Vol. 1, pp. 85-103, 1949.
72. Walston, C. E., and Warren, C. E., "A Mathematical Analysis of the Human Operator in a Closed-Loop Control System", USAF AFPTRC TR 54-96, 1954.
73. Warrick, M. J., "Effect of Transmission-Type Control Lags on Tracking Accuracy", USAF Air Mat. Com. Tech. Report No. 5916, 1949.
74. Welford, A. T., "The Psychological Refractory Period and the Timing of High-Speed Performance: A Review and a Theory", British Journal of Psychology, Vol. 43, pp. 2-19, 1952.
75. Wierwille, W. W., and Gagne, G. A., "Experimental Study of a Deterministic Method for the Characterization of the Time-Varying Dynamics of Human Operators", Sixth Annual Symposium of IEEE PGHF, May 1965.
76. Woodson, W. E., and Conover, D. W., Human Engineering Guide for Equipment Designers, University of California Press, 1964.
77. Young, L. R., and Stark, L., "Biological Control Systems -- A Critical Review and Evaluation", NASA Contractor Report CR-190, 1965.

APPENDIX A

TEST REACTION SHEET	Page 88
-------------------------------	------------

A sheet filled out by each subject after he has finished his group of tests.

LIGHT-ILLUMINATION PROGRAM AND SCORE SHEET

The sheets show the order in which lights 1 through 11 become illuminated and the dwell period of each. The sheets also provide space for scoring each subject for each of the 70 lighting events associated with the given program.

0.00 Second	89
0.27 Second	90
0.50 Second	91
1.00 Second	92
2.60 Second	93
5.00 Second	94
10.00 Second	95

TEST-REACTION SHEET

Name: _____ Age _____ Right handed _____

Undergraduate _____ Do you wear glasses? _____ Left handed _____

Graduate _____ Academic Field of Interest: _____

Do you drive an automobile? _____ Do you fly an airplane? _____

1. Have you ever experienced a delay (other than normal reaction time) in visual feedback before? If "yes", please explain.

2. What was your reaction to the first "time-delay" test in this series?

3. Did your reaction to "operating with a time-delay" change during the series of tests? If so, in what way?

4. Had you ever thought about the problem of "operating with a time-delay"? If so, did you find it more, or less difficult than you expected?

5. Do you think your performance would improve appreciably if you were to go through the same tests a second time (with some rest in the meantime)? If yes, please comment on your reason.

6. Please jot down any other reactions that you experienced during the tests.

7. Please describe any "strategy" that you developed during the tests.

ZERO SECOND PROGRAM

Delay _____ Seconds

Subject _____

Run Number _____

Periods	4.0	1.0	0.45	0.30	0.20	0.14	0.10
Hits							
Misses							

Event	Lt.	Sec.	Hit	Miss
1	2	.45		
2	5	.3		
3	7	.3		
4	8	4		
5	11	.1		
6	6	4		
7	1	.1		
8	9	.14		
9	2	1		
10	8	.1		
11	1	.3		
12	7	.1		
13	5	.45		
14	3	.3		
15	8	.45		
16	2	.2		
17	4	.2		
18	7	.14		
19	10	.45		
20	1	1		
21	11	4		
22	4	.14		
23	11	.3		
24	1	.14		

Event	Lt.	Sec.	Hit	Miss
25	3	.1		
26	8	1		
27	10	.45		
28	6	1		
29	7	.1		
30	5	4		
31	1	.2		
32	5	.1		
33	8	.3		
34	9	.14		
35	7	.45		
36	4	.2		
37	10	.3		
38	1	1		
39	4	4		
40	7	1		
41	6	.14		
42	3	.14		
43	2	.2		
44	10	.45		
45	11	1		
46	7	1		
47	3	4		

Event	Lt.	Sec.	Hit	Miss
48	5	.1		
49	11	4		
50	6	.45		
51	1	.3		
52	10	4		
53	2	.14		
54	1	.2		
55	7	.2		
56	4	4		
57	2	.3		
58	10	.45		
59	4	.14		
60	10	1		
61	2	4		
62	3	1		
63	6	.2		
64	2	.45		
65	11	.1		
66	9	.2		
67	6	.3		
68	9	.2		
69	1	.1		
70	10	.14		

0.27 SECOND PROGRAM

Delay _____ Seconds

Subject _____

Run Number _____

Periods	4.0	1.5	.75	.45	.30	.20	.14
Hits							
Misses							

Event	Lt.	Sec.	Hit	Miss
1	2	.3		
2	10	4		
3	2	1.5		
4	4	.3		
5	5	1.5		
6	3	4		
7	11	.75		
8	1	.2		
9	10	1.5		
10	9	.14		
11	6	.45		
12	8	.75		
13	4	.14		
14	6	.14		
15	1	4		
16	3	4		
17	7	1.5		
18	3	.14		
19	8	.75		
20	7	.45		
21	9	1.5		
22	4	1.5		
23	2	.3		
24	5	.2		

Event	Lt.	Sec.	Hit	Miss
25	8	.75		
26	2	.3		
27	5	.3		
28	11	.75		
29	6	1.5		
30	7	.2		
31	5	4		
32	1	.14		
33	10	.45		
34	7	1.5		
35	3	.45		
36	10	.2		
37	6	1.5		
38	8	.14		
39	4	4		
40	3	.45		
41	5	.2		
42	10	.3		
43	4	.75		
44	8	.14		
45	6	.2		
46	7	4		
47	9	.3		

Event	Lt.	Sec.	Hit	Miss
48	8	.14		
49	2	1.5		
50	3	.75		
51	1	4		
52	4	.2		
53	7	.75		
54	8	.75		
55	7	.2		
56	4	.3		
57	11	4		
58	3	.45		
59	11	4		
60	6	.3		
61	2	.2		
62	3	.45		
63	5	.14		
64	4	.75		
65	11	.3		
66	7	.2		
67	8	.45		
68	5	.45		
69	8	.14		
70	3	.45		

0.50 SECOND PROGRAM

Delay _____ Seconds

Subject _____

Run Number _____

Periods	4.0	2.0	1.0	.50	.33	.27	.2
Hits							
Misses							

Event	Lt.	Sec.	Hit	Miss
1	1	.33		
2	4	1		
3	10	2		
4	3	.33		
5	2	.2		
6	6	.2		
7	7	2		
8	10	.33		
9	1	.5		
10	8	4		
11	3	2		
12	2	.2		
13	11	.27		
14	5	1		
15	10	.27		
16	3	4		
17	1	4		
18	3	.5		
19	9	.33		
20	2	2		
21	9	2		
22	4	.27		
23	1	1		
24	6	.5		

Event	Lt.	Sec.	Hit	Miss
25	4	1		
26	6	4		
27	8	4		
28	9	.27		
29	5	.5		
30	7	.5		
31	2	1		
32	4	.27		
33	6	2		
34	4	1		
35	3	.2		
36	5	.5		
37	1	2		
38	9	.27		
39	1	.5		
40	7	.27		
41	1	.2		
42	9	4		
43	4	.33		
44	8	.27		
45	2	.33		
46	1	1		
47	5	.33		

Event	Lt.	Sec.	Hit	Miss
48	2	4		
49	5	.33		
50	4	2		
51	9	.33		
52	8	1		
53	3	.5		
54	5	.2		
55	10	.27		
56	1	2		
57	10	.2		
58	7	.2		
59	6	4		
60	2	1		
61	1	.5		
62	6	.2		
63	8	.2		
64	2	2		
65	6	1		
66	9	.5		
67	3	.33		
68	2	4		
69	4	4		
70	5	.27		

1.0 SECOND PROGRAM

Delay _____ Seconds

Subject _____

Run Number _____

Periods	12	4	2	1.25	.75	.50	.33
Hits							
Misses							

Event	Lt.	Sec.	Hit	Miss
1	3	12		
2	5	4		
3	8	.75		
4	6	12		
5	11	.5		
6	6	1.25		
7	3	.75		
8	1	4		
9	9	.75		
10	10	12		
11	1	4		
12	9	12		
13	7	12		
14	11	1.25		
15	1	.5		
16	3	.33		
17	8	2		
18	4	.33		
19	7	.33		
20	9	2		
21	5	4		
22	6	.75		
23	5	.75		
24	7	4		

Event	Lt.	Sec.	Hit	Miss
25	2	.75		
26	8	4		
27	6	2		
28	8	.75		
29	7	.33		
30	6	.5		
31	3	.5		
32	7	1.25		
33	4	12		
34	1	.75		
35	5	4		
36	4	1.25		
37	10	12		
38	5	2		
39	7	1.25		
40	9	1.25		
41	8	.33		
42	5	.5		
43	4	.33		
44	8	1.25		
45	1	2		
46	6	2		
47	10	.33		

Event	Lt.	Sec.	Hit	Miss
48	6	.75		
49	9	.5		
50	4	.5		
51	2	12		
52	10	12		
53	7	1.25		
54	11	2		
55	5	.5		
56	1	12		
57	8	4		
58	3	1.25		
59	5	1.25		
60	4	.75		
61	5	4		
62	8	2		
63	6	.5		
64	10	2		
65	9	.5		
66	4	.33		
67	3	2		
68	5	.33		
69	10	4		
70	3	.33		

2.6 SECOND PROGRAM

Delay _____ Seconds

Subject _____

Run Number _____

Periods	12	6	4	2.5	1.5	1	.75
Hits							
Misses							

Event	Lt.	Sec.	Hit	Miss
1	4	6		
2	5	6		
3	7	1.5		
4	8	12		
5	4	12		
6	5	2.5		
7	2	1		
8	5	1		
9	2	12		
10	3	4		
11	6	2.5		
12	8	2.5		
13	1	1		
14	8	2.5		
15	4	6		
16	7	.75		
17	9	1		
18	2	6		
19	7	1.5		
20	6	12		
21	2	2.5		
22	1	1		
23	8	6		
24	7	.75		

Event	Lt.	Sec.	Hit	Miss
25	4	1.5		
26	3	12		
27	8	1.5		
28	7	4		
29	6	.75		
30	1	4		
31	4	1		
32	5	2.5		
33	11	.75		
34	3	6		
35	2	1.5		
36	3	2.5		
37	5	1.5		
38	1	1		
39	7	.75		
40	8	2.5		
41	2	4		
42	4	12		
43	1	.75		
44	10	6		
45	7	12		
46	5	2.5		
47	6	1.5		

Event	Lt.	Sec.	Hit	Miss
48	8	1.5		
49	9	6		
50	2	4		
51	7	1.5		
52	1	1.5		
53	6	6		
54	4	.75		
55	5	12		
56	8	12		
57	9	.75		
58	8	1		
59	9	1		
60	1	4		
61	8	4		
62	2	6		
63	1	1		
64	8	2.5		
65	2	4		
66	3	.75		
67	6	4		
68	7	.75		
69	9	12		
70	10	4		

5.0 SECOND PROGRAM

Delay _____ Seconds

Subject _____

Run Number _____

Periods	25	12	6	4	3	2	1
Hits							
Misses							

Event	Lt.	Sec.	Hit	Miss
1	10	2		
2	8	1		
3	3	6		
4	1	6		
5	4	4		
6	1	2		
7	2	3		
8	9	25		
9	4	2		
10	5	2		
11	1	6		
12	8	4		
13	4	12		
14	2	6		
15	3	1		
16	6	12		
17	10	12		
18	4	12		
19	5	25		
20	8	3		
21	4	1		
22	1	25		
23	10	2		
24	8	25		

Event	Lt.	Sec.	Hit	Miss
25	2	3		
26	10	1		
27	6	1		
28	9	6		
29	2	2		
30	10	1		
31	6	6		
32	3	4		
33	7	6		
34	2	4		
35	1	3		
36	10	25		
37	5	12		
38	6	1		
39	7	25		
40	6	1		
41	9	6		
42	2	3		
43	1	6		
44	7	25		
45	3	4		
46	1	3		
47	4	4		

Event	Lt.	Sec.	Hit	Miss
48	10	1		
49	2	12		
50	3	25		
51	6	12		
52	7	6		
53	10	3		
54	8	12		
55	3	4		
56	2	3		
57	1	3		
58	5	2		
59	10	25		
60	1	4		
61	3	25		
62	9	12		
63	2	1		
64	9	3		
65	1	2		
66	6	4		
67	4	2		
68	6	2		
69	8	12		
70	9	4		

10.0 SECOND PROGRAM

Delay _____ Seconds

Subject _____

Run Number _____

Periods	50	25	12	7.5	5	3.5	2
Hits							
Misses							

Event	Lt.	Sec.	Hit	Miss
1	5	7.5		
2	11	5		
3	7	7.5		
4	9	50		
5	11	7.5		
6	1	7.5		
7	10	7.5		
8	8	25		
9	6	2		
10	10	2		
11	5	7.5		
12	7	25		
13	4	25		
14	6	12		
15	2	3.5		
16	8	3.5		
17	7	50		
18	10	25		
19	11	2		
20	9	25		
21	6	50		
22	10	3.5		
23	9	12		
24	6	3.5		

Event	Lt.	Sec.	Hit	Miss
25	7	5		
26	4	50		
27	10	2		
28	8	50		
29	7	50		
30	5	3.5		
31	2	12		
32	7	12		
33	9	3.5		
34	10	12		
35	6	7.5		
36	1	50		
37	7	50		
38	6	2		
39	8	2		
40	4	3.5		
41	11	12		
42	6	2		
43	10	50		
44	11	2		
45	10	3.5		
46	5	12		
47	1	25		

Event	Lt.	Sec.	Hit	Miss
48	3	25		
49	11	25		
50	5	5		
51	6	12		
52	4	7.5		
53	5	5		
54	1	3.5		
55	5	25		
56	4	5		
57	8	2		
58	1	7.5		
59	2	7.5		
60	4	5		
61	9	50		
62	10	5		
63	4	12		
64	3	2		
65	5	5		
66	10	5		
67	7	25		
68	8	12		
69	9	3.5		
70	7	5		

APPENDIX B

EXPERIMENTAL DATA, MEANS, AND STANDARD DEVIATIONS

Phase 1 Tests	Page
0.00 Second Delay	97
0.27 Second Delay	98
0.50 Second Delay	99
1.00 Second Delay	100
2.60 Second Delay	101
5.00 Second Delay	102
10.00 Second Delay	103
Phase 2 Tests	
0.00 Second Delay	104
0.27 Second Delay	105
0.50 Second Delay	106
1.00 Second Delay	107
2.60 Second Delay	108
5.00 Second Delay	109
10.00 Second Delay	110
Phase 3 Test	111
Phase 4 Test	112

0.00 SECOND DELAY- 0.27 SECOND PROGRAM
INTERVAL D BETWEEN SUCCESSIVE STIMULI (SECONDS)

SUBJECT	4.00	1.50	0.75	0.45	0.30	0.20	0.14
1	---	---	---	---	---	---	---
2	---	---	---	---	---	---	---
3	---	---	---	---	---	---	---
4	---	---	---	---	---	---	---
5	---	---	---	---	---	---	---
6	---	---	---	---	---	---	---
7	1.00	1.00	1.00	0.40	0.20	0.30	0.50
8	---	---	---	---	---	---	---
9	1.00	0.90	0.70	0.80	0.20	0.40	0.40
10	0.90	0.90	0.80	0.50	0.20	0.40	0.20
11	1.00	1.00	0.80	0.70	0.40	0.50	0.30
12	---	---	---	---	---	---	---
13	1.00	1.00	0.90	0.40	0.10	0.10	0.10
14	1.00	1.00	0.80	0.50	0.40	0.40	0.20
15	1.00	1.00	1.00	0.50	0.20	0.20	0.30
16	1.00	1.00	0.90	0.90	0.60	0.30	0.50
17	1.00	1.00	0.80	0.70	0.30	0.10	0.20
18	1.00	0.90	0.80	0.50	0.20	0.00	0.20
19	1.00	1.00	0.80	0.40	0.30	0.30	0.50
20	1.00	0.90	0.80	0.70	0.60	0.10	0.10
21	1.00	0.90	0.50	0.60	0.60	0.30	0.20
22	1.00	1.00	0.50	0.50	0.30	0.30	0.10
23	1.00	1.00	0.80	0.40	0.10	0.30	0.10
24	1.00	1.00	0.80	0.50	0.30	0.50	0.20
25	1.00	0.80	0.40	0.70	0.10	0.10	0.00
26	1.00	1.00	0.80	0.90	0.50	0.50	0.30
27	1.00	1.00	0.80	0.90	0.70	0.30	0.30
28	1.00	1.00	0.90	0.60	0.20	0.40	0.10
29	0.90	0.90	0.40	0.60	0.10	0.10	0.30
30	1.00	0.90	0.70	0.60	0.50	0.40	0.40
31	1.00	0.90	0.80	0.60	0.30	0.60	0.20
TOTALS	22.80	22.00	17.50	13.90	7.40	6.90	5.70
SUBJECTS	23.						
MEAN	0.99	0.96	0.76	0.60	0.32	0.30	0.25
STD DEV	0.03	0.06	0.16	0.16	0.18	0.16	0.16

0.27 SECOND DELAY- 0.27 SECOND PROGRAM
INTERVAL D BETWEEN SUCCESSIVE STIMULI (SECONDS)

SUBJECT	4.00	1.50	0.75	0.45	0.30	0.20	0.14
1	1.00	0.50	0.40	0.20	0.20	0.30	0.20
2	1.00	0.50	0.40	0.20	0.10	0.50	0.20
3	0.90	0.80	0.40	0.70	0.50	0.20	0.30
4	1.00	0.70	0.60	0.30	0.40	0.10	0.10
5	0.80	0.80	0.60	0.30	0.60	0.40	0.20
6	1.00	0.70	0.40	0.50	0.60	0.20	0.30
7	0.90	0.60	0.60	0.40	0.40	0.10	0.20
8	0.90	0.40	0.40	0.60	0.40	0.30	0.60
9	0.70	0.50	0.40	0.40	0.20	0.10	0.10
10	0.90	0.80	0.20	0.20	0.10	0.40	0.20
11	1.00	1.00	0.40	0.70	0.40	0.50	0.30
12	0.90	0.90	0.40	0.30	0.40	0.30	0.20
13	1.00	0.60	0.40	0.20	0.30	0.00	0.00
14	1.00	0.90	0.70	0.50	0.30	0.00	0.20
15	1.00	0.90	0.70	0.30	0.10	0.30	0.20
16	1.00	0.50	0.40	0.50	0.60	0.30	0.40
17	1.00	0.70	0.40	0.20	0.40	0.30	0.20
18	1.00	0.90	0.50	0.20	0.10	0.30	0.00
19	0.80	0.50	0.30	0.40	0.30	0.10	0.40
20	0.80	0.60	0.60	0.30	0.30	0.30	0.30
21	0.90	0.80	0.50	0.20	0.30	0.60	0.10
22	0.90	0.70	0.20	0.30	0.10	0.60	0.20
23	1.00	0.90	0.40	0.40	0.30	0.40	0.50
24	1.00	0.80	0.20	0.40	0.20	0.60	0.30
25	0.90	0.80	0.30	0.20	0.20	0.20	0.10
26	1.00	0.80	0.50	0.60	0.30	0.60	0.20
27	1.00	0.80	0.30	0.40	0.30	0.10	0.20
28	1.00	0.70	0.60	0.30	0.10	0.40	0.10
29	0.90	0.00	0.30	0.20	0.50	0.10	0.10
30	1.00	0.70	0.40	0.30	0.30	0.10	0.00
31	1.00	0.80	0.60	0.30	0.20	0.30	0.40
TOTALS	29.20	21.60	13.50	11.00	9.50	9.00	6.80
SUBJECTS	31.						
MEAN	0.94	0.70	0.44	0.35	0.31	0.29	0.22
STD DEV	0.08	0.20	0.14	0.15	0.15	0.18	0.18

0.50 SECOND DELAY- 0.50 SECOND PROGRAM

INTERVAL D BETWEEN SUCCESSIVE STIMULI (SECONDS)

SUBJECT	4.00	2.00	1.00	0.50	0.33	0.27	0.20
1	0.60	0.70	0.20	0.20	0.40	0.20	0.10
2	0.90	0.50	0.60	0.40	0.10	0.30	0.20
3	1.00	0.90	0.30	0.60	0.40	0.40	0.30
4	0.90	1.00	0.60	0.50	0.60	0.50	0.40
5	1.00	0.40	0.70	0.30	0.10	0.40	0.20
6	1.00	0.90	0.50	0.60	0.50	0.20	0.10
7	0.70	0.60	0.40	0.40	0.30	0.40	0.30
8	1.00	0.70	0.40	0.30	0.10	0.30	0.30
9	0.90	0.50	0.30	0.00	0.20	0.30	0.20
10	1.00	0.90	0.60	0.20	0.20	0.50	0.30
11	1.00	0.80	0.60	0.40	0.60	0.30	0.50
12	1.00	0.70	0.20	0.30	0.40	0.30	0.20
13	1.00	0.80	0.30	0.30	0.10	0.10	0.10
14	1.00	0.40	0.50	0.30	0.40	0.10	0.20
15	1.00	0.30	0.20	0.10	0.20	0.50	0.00
16	0.90	0.30	0.70	0.50	0.50	0.60	0.20
17	0.80	0.10	0.50	0.40	0.50	0.30	0.30
18	1.00	0.50	0.60	0.10	0.20	0.20	0.10
19	0.80	0.40	0.40	0.10	0.00	0.10	0.10
20	0.80	0.50	0.30	0.10	0.10	0.30	0.40
21	0.60	0.50	0.40	0.40	0.30	0.00	0.00
22	0.80	0.50	0.20	0.20	0.30	0.20	0.30
23	0.90	0.70	0.30	0.20	0.20	0.20	0.20
24	0.50	0.40	0.40	0.30	0.10	0.20	0.10
25	0.70	0.20	0.40	0.10	0.30	0.00	0.20
26	0.80	0.80	0.60	0.40	0.10	0.40	0.20
27	0.80	0.50	0.40	0.10	0.30	0.40	0.00
28	1.00	0.50	0.50	0.40	0.20	0.30	0.30
29	0.50	0.40	0.40	0.10	0.10	0.10	0.30
30	1.00	0.60	0.50	0.30	0.40	0.30	0.30
31	0.80	0.70	0.20	0.30	0.30	0.10	0.30
TOTALS	26.70	17.70	13.20	8.90	8.50	8.50	6.70
SUBJECTS	31.						
MEAN	0.86	0.57	0.43	0.29	0.27	0.27	0.22
STD DEV	0.16	0.22	0.15	0.16	0.16	0.15	0.15

1.00 SECOND DELAY- 1.00 SECOND PROGRAM

INTERVAL D BETWEEN SUCCESSIVE STIMULI (SECONDS)

SUBJECT	12.00	4.00	2.00	1.25	0.75	0.50	0.33
1	0.90	0.50	0.30	0.30	0.20	0.10	0.20
2	0.80	0.70	0.50	0.70	0.40	0.10	0.30
3	1.00	1.00	0.60	0.50	0.50	0.20	0.40
4	---	---	---	---	---	---	---
5	0.60	0.80	0.40	0.40	0.50	0.30	0.40
6	1.00	0.90	0.80	0.90	0.50	0.50	0.10
7	1.00	0.70	0.60	0.40	0.30	0.30	0.40
8	1.00	0.90	0.70	0.90	0.60	0.30	0.40
9	---	---	---	---	---	---	---
10	1.00	0.80	0.40	0.60	0.60	0.40	0.20
11	1.00	0.70	0.60	0.90	0.70	0.50	0.40
12	1.00	0.60	0.40	0.20	0.60	0.30	0.20
13	0.90	0.90	0.60	0.40	0.40	0.10	0.00
14	1.00	0.90	0.90	0.60	0.40	0.30	0.10
15	1.00	0.90	0.60	0.40	0.50	0.20	0.20
16	1.00	0.90	0.70	0.60	0.60	0.80	0.90
17	1.00	0.90	0.70	0.40	0.50	0.40	0.50
18	0.90	0.70	0.60	0.50	0.50	0.30	0.20
19	1.00	0.60	0.50	0.30	0.50	0.00	0.30
20	1.00	0.50	0.40	0.30	0.40	0.30	0.50
21	1.00	1.00	0.40	0.50	0.50	0.30	0.30
22	0.90	0.50	0.70	0.70	0.50	0.20	0.50
23	0.90	0.60	0.80	0.70	0.70	0.30	0.50
24	0.80	0.40	0.30	0.40	0.70	0.30	0.30
25	1.00	0.50	0.30	0.50	0.10	0.20	0.20
26	1.00	0.80	0.90	0.50	0.70	0.40	0.50
27	0.90	0.60	0.50	0.40	0.80	0.10	0.20
28	0.90	0.80	0.20	0.40	0.40	0.20	0.20
29	0.70	0.70	0.60	0.50	0.80	0.40	0.40
30	1.00	0.60	0.60	0.40	0.50	0.40	0.30
31	1.00	1.00	0.50	0.40	0.50	0.40	0.20
TOTALS	27.20	21.40	16.10	14.70	14.90	8.60	9.30
SUBJECTS	29.						
MEAN	0.94	0.74	0.56	0.51	0.51	0.30	0.32
STD DEV	0.10	0.17	0.18	0.18	0.16	0.16	0.16

2.60 SECOND DELAY- 2.60 SECOND PROGRAM
INTERVAL D BETWEEN SUCCESSIVE STIMULI (SECONDS)

SUBJECT	12.00	6.00	4.00	2.50	1.50	1.00	0.75
1	1.00	0.50	0.30	0.40	0.40	0.40	0.30
2	0.80	0.70	0.40	0.40	0.50	0.50	0.30
3	1.00	0.60	0.50	0.60	0.90	0.40	0.30
4	0.90	0.80	0.60	0.30	0.90	0.70	0.40
5	---	---	---	---	---	---	---
6	1.00	1.00	1.00	0.60	0.40	0.70	0.40
7	1.00	0.50	0.40	0.40	0.60	0.20	0.60
8	1.00	0.60	0.40	0.70	0.60	0.50	0.20
9	0.80	0.50	0.70	0.10	0.10	0.30	0.10
10	1.00	0.90	0.20	0.50	0.60	0.30	0.60
11	0.90	0.60	0.40	0.90	0.60	0.50	0.40
12	0.60	0.50	0.60	0.40	0.40	0.10	0.30
13	1.00	0.50	0.60	0.50	0.60	0.00	0.20
14	0.90	0.90	0.50	0.20	0.50	0.60	0.70
15	0.90	0.40	0.40	0.50	0.30	0.40	0.70
16	1.00	0.90	0.90	0.60	0.70	0.70	0.70
17	1.00	0.90	0.50	0.90	0.70	0.90	0.50
18	1.00	0.70	0.40	0.50	0.50	0.30	0.50
19	1.00	0.40	0.30	0.30	0.20	0.20	0.20
20	0.90	0.40	0.50	0.40	0.50	0.20	0.50
21	0.90	0.50	0.40	0.40	0.70	0.20	0.40
22	0.50	0.40	0.70	0.50	0.40	0.60	0.30
23	1.00	0.70	0.60	0.40	0.60	0.40	0.30
24	0.90	0.50	0.50	0.40	0.60	0.50	0.60
25	0.90	0.60	0.60	0.70	0.50	0.60	0.40
26	0.90	0.80	0.70	0.80	0.60	0.40	1.00
27	0.80	0.50	0.30	0.70	0.50	0.20	0.50
28	1.00	0.70	0.60	0.80	0.30	0.50	0.40
29	0.90	0.40	0.40	0.40	0.60	0.10	0.30
30	0.80	0.60	0.80	0.60	0.80	0.60	0.50
31	1.00	0.60	0.60	0.60	0.60	0.50	0.40
TOTALS	27.30	18.60	15.80	15.50	16.20	12.50	13.00
SUBJECTS	30.						
MEAN	0.91	0.62	0.53	0.52	0.54	0.42	0.43
STD DEV	0.12	0.18	0.18	0.19	0.18	0.21	0.21

5.00 SECOND DELAY- 5.00 SECOND PROGRAM
INTERVAL D BETWEEN SUCCESSIVE STIMULI (SECONDS)

SUBJECT	25.00	12.00	6.00	4.00	3.00	2.00	1.00
1	1.00	0.70	0.60	0.50	0.80	0.50	0.50
2	0.80	0.80	0.90	0.40	0.50	0.20	0.20
3	0.90	0.80	0.50	0.50	0.60	0.30	0.50
4	1.00	1.00	0.70	0.90	0.90	0.80	0.50
5	0.90	0.90	0.70	0.40	0.50	0.30	0.60
6	1.00	0.80	0.60	0.50	0.50	0.50	0.40
7	1.00	0.70	0.40	0.60	0.30	0.50	0.80
8	1.00	1.00	0.30	0.60	0.50	0.20	0.20
9	0.70	0.50	0.80	0.20	0.30	0.20	0.30
10	1.00	1.00	0.40	0.90	0.60	0.50	0.40
11	0.90	0.60	0.30	0.40	0.50	0.40	0.50
12	1.00	0.80	0.30	0.20	0.60	0.50	0.70
13	1.00	0.90	0.80	0.60	0.60	0.50	0.30
14	1.00	0.50	0.20	0.40	0.40	0.70	0.70
15	0.90	0.90	0.50	0.40	0.60	0.30	0.30
16	0.90	0.50	0.40	0.30	0.80	0.60	0.40
17	1.00	0.70	0.20	0.40	0.40	0.20	0.50
18	1.00	0.50	0.70	0.40	0.30	0.40	0.10
19	0.80	0.50	0.30	0.50	0.30	0.30	0.10
20	1.00	0.50	0.10	0.50	0.30	0.40	0.40
21	0.90	1.00	0.60	0.70	0.40	0.40	0.60
22	0.90	0.90	0.30	0.50	0.40	0.20	0.70
23	0.80	0.70	0.50	0.60	0.30	0.20	0.40
24	0.90	0.90	0.60	0.50	0.50	0.60	0.40
25	1.00	1.00	0.50	0.50	0.60	0.50	0.40
26	1.00	0.70	0.50	0.20	0.30	0.90	0.70
27	0.80	0.90	0.40	0.50	0.50	0.60	0.60
28	1.00	1.00	0.50	0.20	0.30	0.30	0.40
29	1.00	0.90	0.70	0.60	0.40	0.70	0.30
30	1.00	1.00	0.80	0.60	0.60	0.70	0.60
31	1.00	0.90	0.40	0.60	0.50	0.60	0.40
TOTALS	29.10	24.50	15.50	15.10	15.10	13.50	13.90
SUBJECTS	31.						
MEAN	0.94	0.79	0.50	0.49	0.49	0.44	0.45
STD DEV	0.08	0.18	0.20	0.17	0.16	0.19	0.19

10.00 SECONDD DELAY-10.00 SECONDD PROGRAM
INTERVAL D BETWEEN SUCCESSIVE STIMULI (SECONDS)

SUBJECT	50.00	25.00	12.00	7.50	5.00	3.50	2.00
1	1.00	0.70	0.60	0.60	0.30	0.70	0.60
2	1.00	1.00	0.70	0.70	0.90	0.90	0.70
3	1.00	0.80	0.50	0.50	0.40	0.30	0.30
4	1.00	1.00	1.00	1.00	1.00	1.00	0.90
5	0.70	0.80	0.80	0.60	0.40	0.40	0.40
6	1.00	1.00	0.70	0.60	0.60	0.60	0.10
7	1.00	0.90	0.60	0.70	0.70	0.60	0.50
8	0.80	1.00	0.70	0.40	0.50	0.30	0.30
9	0.90	0.70	0.40	0.40	0.80	0.40	0.20
10	1.00	0.70	0.50	0.60	0.60	0.50	0.80
11	1.00	0.90	0.50	0.50	1.00	0.50	0.60
12	0.80	0.90	0.30	0.60	0.40	0.50	0.60
13	1.00	0.60	0.70	0.50	0.40	0.40	0.40
14	---	---	---	---	---	---	---
15	1.00	1.00	0.50	0.50	0.50	0.80	0.30
16	1.00	0.90	0.70	0.50	0.50	0.90	0.80
17	1.00	0.80	0.60	0.50	0.50	0.50	0.40
18	1.00	0.90	0.80	0.60	0.60	0.50	0.30
19	0.80	0.30	0.40	0.40	0.40	0.60	0.30
20	1.00	0.70	0.50	0.30	0.30	0.40	0.30
21	0.90	0.90	0.50	0.60	0.30	0.50	0.70
22	1.00	0.70	0.70	0.60	0.70	0.90	0.10
23	0.80	0.80	0.50	0.20	0.60	0.30	0.60
24	1.00	0.50	0.40	0.30	0.40	0.60	0.40
25	1.00	0.80	0.30	0.90	0.40	0.70	0.60
26	1.00	0.70	0.70	0.80	0.50	0.50	0.80
27	0.90	1.00	0.30	0.10	0.50	0.70	0.40
28	1.00	0.80	0.50	0.50	0.50	0.50	0.50
29	1.00	0.80	0.70	0.10	0.20	0.50	0.30
30	1.00	1.00	0.80	0.70	0.70	0.50	0.60
31	1.00	0.80	0.70	0.20	0.50	0.50	0.40
TOTALS	28.60	24.40	17.60	15.50	16.10	17.00	14.20
SUBJECTS	30.						
MEAN	0.95	0.81	0.59	0.52	0.54	0.57	0.47
STD DEV	0.09	0.16	0.17	0.21	0.20	0.19	0.19

0.00 SECOND DELAY- 0.00 SECOND PROGRAM

INTERVAL D BETWEEN SUCCESSIVE STIMULI (SECONDS)

SUBJECT	4.00	1.00	0.45	0.30	0.20	0.14	0.10
1	0.90	1.00	0.20	0.40	0.20	0.30	0.00
2	1.00	1.00	0.50	0.50	0.10	0.20	0.10
3	1.00	1.00	0.40	0.50	0.10	0.10	0.00
4	1.00	0.90	0.40	0.40	0.20	0.10	0.00
5	---	---	---	---	---	---	---
6	0.90	0.90	0.30	0.20	0.10	0.20	0.10
7	1.00	0.90	0.50	0.30	0.40	0.30	0.10
8	0.90	0.70	0.30	0.20	0.30	0.00	0.00
9	1.00	1.00	0.50	0.60	0.40	0.10	0.00
10	1.00	0.70	0.70	0.40	0.30	0.10	0.20
11	1.00	1.00	0.50	0.70	0.10	0.50	0.10
12	1.00	0.70	0.30	0.30	0.20	0.20	0.10
13	1.00	0.60	0.40	0.40	0.10	0.10	0.00
14	0.90	0.80	0.60	0.40	0.10	0.30	0.10
15	1.00	0.90	0.20	0.50	0.10	0.00	0.40
16	1.00	0.70	0.50	0.50	0.20	0.30	0.00
17	1.00	0.80	0.60	0.20	0.30	0.40	0.10
18	---	---	---	---	---	---	---
19	1.00	0.40	0.30	0.40	0.10	0.20	0.10
20	1.00	0.60	0.10	0.40	0.10	0.20	0.10
21	1.00	0.60	0.40	0.30	0.30	0.30	0.10
22	1.00	0.90	0.70	0.40	0.20	0.00	0.20
23	0.90	0.70	0.30	0.10	0.10	0.20	0.20
24	1.00	0.80	0.50	0.50	0.00	0.30	0.20
25	1.00	0.70	0.10	0.50	0.20	0.00	0.10
26	1.00	0.80	0.60	0.50	0.20	0.10	0.10
27	1.00	0.60	0.30	0.30	0.20	0.40	0.00
28	1.00	0.70	0.30	0.40	0.40	0.20	0.20
29	1.00	0.40	0.20	0.40	0.10	0.10	0.30
30	0.90	0.70	0.60	0.50	0.20	0.10	0.00
31	1.00	0.90	0.30	0.30	0.40	0.30	0.20
TOTALS	28.40	22.40	11.60	11.50	5.70	5.60	3.10
SUBJECTS	29.						
MEAN	0.98	0.77	0.40	0.40	0.20	0.19	0.11
STD DEV	0.04	0.17	0.17	0.13	0.11	0.13	0.13

0.27 SECOND DELAY- 0.00 SECOND PROGRAM
INTERVAL D BETWEEN SUCCESSIVE STIMULI (SECONDS)

SUBJECT	4.00	1.00	0.45	0.30	0.20	0.14	0.10
1	---	---	---	---	---	---	---
2	---	---	---	---	---	---	---
3	---	---	---	---	---	---	---
4	---	---	---	---	---	---	---
5	---	---	---	---	---	---	---
6	---	---	---	---	---	---	---
7	1.00	0.30	0.20	0.30	0.20	0.20	0.20
8	---	---	---	---	---	---	---
9	0.60	0.20	0.30	0.50	0.20	0.70	0.00
10	1.00	0.60	0.50	0.50	0.10	0.20	0.20
11	1.00	0.80	0.70	0.60	0.40	0.40	0.10
12	1.00	0.60	0.30	0.20	0.10	0.20	0.40
13	1.00	0.40	0.30	0.10	0.10	0.10	0.10
14	1.00	0.60	0.50	0.30	0.20	0.20	0.00
15	1.00	0.40	0.50	0.30	0.00	0.30	0.10
16	---	---	---	---	---	---	---
17	1.00	0.40	0.50	0.40	0.20	0.00	0.10
18	0.90	0.40	0.40	0.40	0.00	0.00	0.00
19	0.90	0.20	0.20	0.00	0.10	0.30	0.00
20	0.80	0.70	0.20	0.30	0.00	0.10	0.00
21	1.00	0.70	0.20	0.40	0.00	0.10	0.10
22	1.00	0.30	0.30	0.20	0.20	0.20	0.10
23	1.00	0.50	0.30	0.40	0.10	0.10	0.10
24	0.90	0.50	0.40	0.30	0.20	0.10	0.40
25	0.90	0.10	0.00	0.30	0.30	0.20	0.30
26	0.90	0.70	0.50	0.50	0.10	0.10	0.10
27	1.00	0.30	0.50	0.30	0.10	0.00	0.00
28	1.00	0.40	0.10	0.40	0.20	0.10	0.20
29	0.90	0.50	0.20	0.30	0.10	0.10	0.20
30	1.00	0.40	0.20	0.20	0.30	0.00	0.10
31	1.00	0.50	0.40	0.20	0.10	0.20	0.10
TOTALS	21.80	10.50	7.70	7.40	3.30	3.90	2.90
SUBJECTS	23.						
MEAN	0.95	0.46	0.33	0.32	0.14	0.17	0.13
STD DEV	0.09	0.18	0.16	0.14	0.10	0.16	0.16

0.50 SECOND DELAY- 0.00 SECOND PROGRAM
INTERVAL D BETWEEN SUCCESSIVE STIMULI (SECONDS)

SUBJECT	4.00	1.00	0.45	0.30	0.20	0.14	0.10
1	---	---	---	---	---	---	---
2	---	---	---	---	---	---	---
3	---	---	---	---	---	---	---
4	---	---	---	---	---	---	---
5	---	---	---	---	---	---	---
6	---	---	---	---	---	---	---
7	1.00	0.20	0.60	0.30	0.10	0.30	0.20
8	---	---	---	---	---	---	---
9	0.60	0.40	0.20	0.10	0.20	0.20	0.10
10	0.90	0.50	0.10	0.50	0.00	0.00	0.10
11	1.00	0.80	0.40	0.30	0.20	0.00	0.10
12	---	---	---	---	---	---	---
13	1.00	0.40	0.20	0.40	0.00	0.00	0.20
14	0.80	0.30	0.20	0.20	0.00	0.10	0.10
15	0.70	0.40	0.00	0.50	0.10	0.10	0.00
16	---	---	---	---	---	---	---
17	0.80	0.20	0.40	0.50	0.50	0.10	0.10
18	0.90	0.50	0.10	0.30	0.10	0.20	0.20
19	0.60	0.30	0.40	0.10	0.20	0.00	0.10
20	0.80	0.10	0.20	0.30	0.30	0.20	0.30
21	1.00	0.20	0.00	0.10	0.00	0.10	0.10
22	0.90	0.40	0.40	0.50	0.40	0.30	0.00
23	1.00	0.50	0.30	0.50	0.10	0.20	0.30
24	0.80	0.30	0.20	0.30	0.10	0.10	0.20
25	0.80	0.20	0.10	0.10	0.20	0.10	0.10
26	1.00	0.50	0.30	0.50	0.00	0.20	0.00
27	0.90	0.30	0.00	0.00	0.00	0.10	0.00
28	1.00	0.70	0.20	0.10	0.10	0.00	0.10
29	0.80	0.00	0.00	0.40	0.20	0.20	0.50
30	0.80	0.40	0.10	0.20	0.10	0.10	0.10
31	0.80	0.20	0.30	0.20	0.20	0.10	0.20
TOTALS	18.90	7.80	4.70	6.40	3.10	2.70	3.10
SUBJECTS	22.						
MEAN	0.86	0.35	0.21	0.29	0.14	0.12	0.14
STD DEV	0.13	0.19	0.16	0.17	0.13	0.09	0.09

1.00 SECOND DELAY- 0.00 SECOND PROGRAM
 INTERVAL D BETWEEN SUCCESSIVE STIMULI (SECONDS)

SUBJECT	4.00	1.00	0.45	0.30	0.20	0.14	0.10
1	---	---	---	---	---	---	---
2	---	---	---	---	---	---	---
3	---	---	---	---	---	---	---
4	---	---	---	---	---	---	---
5	---	---	---	---	---	---	---
6	---	---	---	---	---	---	---
7	0.60	0.10	0.00	0.20	0.20	0.20	0.20
8	---	---	---	---	---	---	---
9	0.30	0.30	0.00	0.20	0.10	0.00	0.30
10	0.70	0.30	0.10	0.30	0.20	0.10	0.20
11	0.80	0.90	0.30	0.30	0.10	0.10	0.20
12	0.70	0.60	0.40	0.10	0.20	0.20	0.00
13	0.80	0.30	0.20	0.10	0.00	0.00	0.00
14	---	---	---	---	---	---	---
15	---	---	---	---	---	---	---
16	0.90	0.70	0.40	0.50	0.10	0.40	0.10
17	0.80	0.30	0.50	0.40	0.10	0.10	0.10
18	0.60	0.70	0.10	0.30	0.10	0.00	0.10
19	0.90	0.20	0.20	0.20	0.10	0.00	0.00
20	0.50	0.40	0.20	0.20	0.00	0.20	0.10
21	0.90	0.30	0.30	0.00	0.30	0.20	0.30
22	0.70	0.30	0.00	0.40	0.20	0.30	0.40
23	0.80	0.50	0.00	0.60	0.00	0.10	0.20
24	0.80	0.40	0.20	0.30	0.00	0.00	0.00
25	0.50	0.40	0.10	0.10	0.00	0.20	0.10
26	0.70	0.80	0.10	0.40	0.10	0.10	0.20
27	0.90	0.30	0.40	0.20	0.10	0.10	0.10
28	0.80	0.30	0.20	0.50	0.00	0.00	0.10
29	0.80	0.20	0.10	0.30	0.10	0.30	0.20
30	0.50	0.20	0.20	0.20	0.00	0.00	0.00
31	0.80	0.40	0.00	0.40	0.00	0.10	0.10
TOTALS	15.80	8.90	4.00	6.20	2.00	2.70	3.00
SUBJECTS	22.						
MEAN	0.72	0.40	0.18	0.28	0.09	0.12	0.14
STD DEV	0.16	0.21	0.15	0.15	0.09	0.12	0.12

2.60 SECOND DELAY- 1.00 SECOND PROGRAM
INTERVAL D BETWEEN SUCCESSIVE STIMULI (SECONDS)

SUBJECT	12.00	4.00	2.00	1.25	0.75	0.50	0.33
1	---	---	---	---	---	---	---
2	---	---	---	---	---	---	---
3	---	---	---	---	---	---	---
4	---	---	---	---	---	---	---
5	---	---	---	---	---	---	---
6	---	---	---	---	---	---	---
7	0.80	0.40	0.40	0.30	0.40	0.40	0.50
8	---	---	---	---	---	---	---
9	0.80	0.80	0.10	0.30	0.20	0.20	0.00
10	1.00	0.50	0.50	0.40	0.40	0.10	0.30
11	0.70	0.80	0.50	0.80	0.50	0.40	0.50
12	1.00	0.30	0.50	0.50	0.20	0.30	0.30
13	1.00	0.80	0.50	0.40	0.30	0.00	0.20
14	1.00	0.50	0.50	0.30	0.40	0.30	0.60
15	0.80	0.80	0.40	0.20	0.20	0.10	0.20
16	1.00	0.70	0.70	0.60	0.40	0.60	0.60
17	1.00	0.40	0.10	0.60	0.20	0.30	0.30
18	1.00	0.50	0.40	0.30	0.20	0.20	0.20
19	1.00	0.50	0.30	0.60	0.50	0.10	0.10
20	0.80	0.60	0.30	0.20	0.50	0.20	0.10
21	0.80	0.50	0.20	0.60	0.70	0.30	0.30
22	0.90	0.50	0.30	0.40	0.30	0.20	0.10
23	0.90	0.50	0.50	0.70	0.40	0.40	0.20
24	0.90	0.30	0.80	0.70	0.20	0.40	0.40
25	0.70	0.20	0.40	0.50	0.40	0.50	0.20
26	1.00	0.90	0.60	0.80	0.70	0.50	0.40
27	1.00	0.40	0.20	0.50	0.10	0.00	0.20
28	1.00	0.60	0.50	0.50	0.60	0.00	0.30
29	0.90	0.70	0.10	0.50	0.30	0.50	0.30
30	1.00	0.50	0.40	0.60	0.50	0.30	0.30
31	0.80	0.30	0.20	0.30	0.10	0.40	0.40
TOTALS	21.80	13.00	9.40	11.60	8.70	6.70	7.00
SUBJECTS	24.						
MEAN	0.91	0.54	0.39	0.48	0.36	0.28	0.29
STD DEV	0.11	0.19	0.18	0.18	0.17	0.17	0.17

5.00 SECOND DELAY- 1.00 SECOND PROGRAM
INTERVAL D BETWEEN SUCCESSIVE STIMULI (SECONDS)

SUBJECT	12.00	4.00	2.00	1.25	0.75	0.50	0.33
1	---	---	---	---	---	---	---
2	---	---	---	---	---	---	---
3	---	---	---	---	---	---	---
4	---	---	---	---	---	---	---
5	---	---	---	---	---	---	---
6	---	---	---	---	---	---	---
7	0.80	0.60	0.60	0.70	0.50	0.80	0.40
8	---	---	---	---	---	---	---
9	0.50	0.20	0.40	0.00	0.30	0.00	0.10
10	0.80	0.70	0.60	0.40	0.30	0.40	0.30
11	0.80	0.00	0.60	0.20	0.20	0.10	0.00
12	0.40	0.30	0.20	0.40	0.30	0.10	0.20
13	0.90	0.70	0.40	0.40	0.30	0.20	0.00
14	0.80	0.50	0.20	0.20	0.30	0.10	0.30
15	0.70	0.40	0.50	0.50	0.30	0.00	0.00
16	0.70	0.30	0.10	0.30	0.40	0.30	0.00
17	0.60	0.50	0.30	0.40	0.20	0.10	0.40
18	0.60	0.50	0.20	0.40	0.30	0.10	0.30
19	0.50	0.10	0.30	0.40	0.20	0.20	0.30
20	0.60	0.30	0.00	0.40	0.30	0.10	0.30
21	0.60	0.40	0.30	0.30	0.20	0.20	0.10
22	0.60	0.30	0.20	0.10	0.50	0.10	0.10
23	0.80	0.10	0.00	0.30	0.10	0.20	0.20
24	0.80	0.50	0.50	0.50	0.40	0.10	0.40
25	0.60	0.30	0.40	0.30	0.30	0.20	0.10
26	0.80	0.50	0.60	0.40	0.50	0.00	0.30
27	0.80	0.30	0.40	0.30	0.10	0.00	0.00
28	0.80	0.10	0.40	0.40	0.30	0.10	0.10
29	1.00	0.80	0.40	0.70	0.20	0.20	0.60
30	0.90	0.40	0.10	0.50	0.20	0.10	0.00
31	0.80	0.80	0.30	0.40	0.30	0.20	0.10
TOTALS	17.20	9.60	8.00	8.90	7.00	3.90	4.60
SUBJECTS	24.						
MEAN	0.72	0.40	0.33	0.37	0.29	0.16	0.19
STD DEV	0.15	0.22	0.18	0.16	0.11	0.17	0.17

10.00 SECOND DELAY- 2.60 SECOND PROGRAM
INTERVAL D BETWEEN SUCCESSIVE STIMULI (SECONDS)

SUBJECT	12.00	6.00	4.00	2.50	1.50	1.00	0.75
1	---	---	---	---	---	---	---
2	---	---	---	---	---	---	---
3	---	---	---	---	---	---	---
4	---	---	---	---	---	---	---
5	---	---	---	---	---	---	---
6	---	---	---	---	---	---	---
7	0.50	0.60	0.40	0.30	0.30	0.60	0.30
8	---	---	---	---	---	---	---
9	0.30	0.20	0.50	0.50	0.20	0.20	0.30
10	0.70	0.50	0.80	0.50	0.40	0.40	0.40
11	0.70	0.30	0.40	0.30	0.20	0.10	0.40
12	0.50	0.30	0.20	0.30	0.70	0.50	0.30
13	0.60	0.30	0.20	0.30	0.20	0.00	0.10
14	0.40	0.40	0.40	0.20	0.30	0.20	0.40
15	0.30	0.30	0.10	0.50	0.40	0.30	0.30
16	0.80	0.30	0.70	0.60	0.80	0.40	0.60
17	0.40	0.40	0.50	0.40	0.70	0.10	0.20
18	0.60	0.50	0.70	0.60	0.50	0.40	0.40
19	0.30	0.50	0.40	0.40	0.40	0.20	0.30
20	0.40	0.40	0.50	0.20	0.10	0.20	0.40
21	0.50	0.10	0.40	0.10	0.20	0.10	0.30
22	1.00	0.60	0.50	0.70	0.50	0.60	0.50
23	0.40	0.60	0.10	0.40	0.20	0.40	0.30
24	0.50	0.30	0.50	0.40	0.40	0.10	0.20
25	0.50	0.10	0.10	0.20	0.20	0.60	0.20
26	0.70	0.40	0.60	0.40	0.40	0.40	0.60
27	0.50	0.30	0.50	0.30	0.10	0.50	0.20
28	0.50	0.40	0.40	0.30	0.50	0.20	0.20
29	0.10	0.40	0.30	0.20	0.20	0.30	0.20
30	0.50	0.30	0.40	0.10	0.10	0.20	0.30
31	0.20	0.10	0.20	0.20	0.50	0.10	0.10
TOTALS	11.90	8.60	9.80	8.40	8.50	7.10	7.50
SUBJECTS	24.						
MEAN	0.50	0.36	0.41	0.35	0.35	0.30	0.31
STD DEV	0.20	0.15	0.19	0.16	0.20	0.18	0.18

PHASE THREE

LEARNING TESTS FOR .50 SECOND PROGRAM-.50 SECOND DELAY

TEST NUMBER

SUBJECT	1	2	3	4	5	6	7	8
1	21.00	27.00	20.00	31.00	31.00	31.00	27.00	32.00
2	28.00	31.00	25.00	32.00	25.00	28.00	33.00	33.00
3	24.00	30.00	32.00	33.00	36.00	31.00	35.00	34.00
4	29.00	34.00	30.00	31.00	29.00	34.00	32.00	26.00
5	29.00	35.00	29.00	29.00	36.00	22.00	30.00	27.00
TOTALS	131.00	157.00	136.00	156.00	157.00	146.00	157.00	152.00
MEAN	26.20	31.40	27.20	31.20	31.40	29.20	31.40	30.40
GRAND MEAN		30.56						
STD DEV	3.56	3.21	4.76	1.48	4.72	4.55	3.05	3.65
OVERALL STD. DEV.			2.48					
STRAIGHT LINE APPROX. :			SLOPE = 0.60		INTERCEPT = 27.28			r ST

111

PHASE FOUR

OPEN LOOP TESTS FOR .50 SECOND PROGRAM-.50 SECOND DELAY

TEST NUMBER

SUBJECT	1	2	3	4	5
1	13.00	7.00	9.00	16.00	6.00
2	13.00	14.00	11.00	24.00	14.00
3	14.00	19.00	23.00	16.00	16.00
4	13.00	7.00	34.00	13.00	9.00
5	14.00	10.00	8.00	16.00	23.00
TOTALS	67.00	57.00	85.00	85.00	68.00
MEAN	13.40	11.40	17.00	17.00	13.60
GRAND MEAN		14.48			
STD DEV	0.55	5.13	11.25	4.12	6.58
OVERALL STD. DEV.			2.46		

"The aeronautical and space activities of the United States shall be conducted so as to contribute . . . to the expansion of human knowledge of phenomena in the atmosphere and space. The Administration shall provide for the widest practicable and appropriate dissemination of information concerning its activities and the results thereof."

—NATIONAL AERONAUTICS AND SPACE ACT OF 1958

NASA SCIENTIFIC AND TECHNICAL PUBLICATIONS

TECHNICAL REPORTS: Scientific and technical information considered important, complete, and a lasting contribution to existing knowledge.

TECHNICAL NOTES: Information less broad in scope but nevertheless of importance as a contribution to existing knowledge.

TECHNICAL MEMORANDUMS: Information receiving limited distribution because of preliminary data, security classification, or other reasons.

CONTRACTOR REPORTS: Technical information generated in connection with a NASA contract or grant and released under NASA auspices.

TECHNICAL TRANSLATIONS: Information published in a foreign language considered to merit NASA distribution in English.

TECHNICAL REPRINTS: Information derived from NASA activities and initially published in the form of journal articles.

SPECIAL PUBLICATIONS: Information derived from or of value to NASA activities but not necessarily reporting the results of individual NASA-programmed scientific efforts. Publications include conference proceedings, monographs, data compilations, handbooks, sourcebooks, and special bibliographies.

Details on the availability of these publications may be obtained from:

SCIENTIFIC AND TECHNICAL INFORMATION DIVISION
NATIONAL AERONAUTICS AND SPACE ADMINISTRATION
Washington, D.C. 20546