

AD



RSIC-508

Volume I DAMPING CAPACITY OF MATERIALS

M10

by
Robert E. Maringer

7100
1175

January 1966

Battelle Memorial Institute
Contract No. DA-01-021-AMC-11706 (Z)

DISTRIBUTION OF THIS DOCUMENT IS UNLIMITED

REDSTONE SCIENTIFIC INFORMATION CENTER REDSTONE ARSENAL, ALABAMA

JOINTLY SUPPORTED BY



U.S. ARMY MISSILE COMMAND



GEORGE C. MARSHALL SPACE FLIGHT CENTER

FACILITY FORM 602
N67 12059
390
CK-80143

DISPOSITION INSTRUCTIONS

Destroy this report when it is no longer needed. Do not return it to the originator.

DISCLAIMER

The findings in this report are not to be construed as an official Department of the Army position, unless so designated by other authorized documents.

3 January 1966

RSIC - 508

Volume I
DAMPING CAPACITY OF MATERIALS

by
Robert E. Maringer

Battelle Memorial Institute
Columbus Laboratories
505 King Avenue
Columbus, Ohio 43201

Contract No. DA-01-021-AMC-11706 (Z)

DISTRIBUTION OF THIS DOCUMENT IS UNLIMITED

Research Branch
Research and Development Directorate
Redstone Scientific Information Center
U. S. Army Missile Command
Redstone Arsenal, Alabama 35809

ABSTRACT

This report contains a brief introduction to the field of damping capacity in materials and an extensive, annotated bibliography. The introductory material presents the fundamentals of damping, general methods of measuring internal friction or damping capacity, and some representative damping properties. The bibliography contains over 2300 references to pertinent literature published from 1955 through 1965, and is cross-indexed by both author and subject.

In addition, computer searches were run by Defense Documentation Center and by the National Aeronautics and Space Administration for location of pertinent literature published during the last four years. Articles, books, and papers are listed alphabetically by the author's last name. (Where there is more than one author, the alphabetical listing is by last name of first author.) Reports are listed alphabetically by the corporate author, that is, by the corporation, company, or agency from which the report originated.

FOREWORD

The purpose of this report is to present a collection of authoritative timely references in the field of material damping (internal friction) and to organize these references in an easily accessible manner. The introductory discussion of various aspects of internal friction is not meant to be exhaustive, nor is it meant for the expert. Its purpose is to provide the reader, not familiar with damping phenomena, a sufficient background to understand and to utilize the damping literature cited.

The author in compiling this bibliography has attempted to make as complete a list as possible of recent sources of information on damping capacity of materials. This bibliography begins with citations from 1955 and continues through 1965. An existing literature survey covers damping of materials before 1955. (Wright Air Development Center, BIBLIOGRAPHY OF THE MATERIAL DAMPING FIELD by L. J. Demer, June 1956, TR-56-180.)

Abstracts contained herein were taken directly from abstract journals, wherever possible. The sources consulted were:

- (1) American Society for Metals Review of Metals Literature
- (2) Applied Science and Technology Index
- (3) Ceramic Abstracts
- (4) Chemical Abstracts
- (5) Engineering Index
- (6) Iron and Steel Institute Abstracts
- (7) Nuclear Science Abstracts
- (8) Physics Abstracts
- (9) Rubber Abstracts

The author is grateful to Mr. P. R. Held for his diligence in compiling this information, and for the efforts of Misses Sue Fribley, Kathy Shafer, and Nancy Ciccone, and a number of other staff members, particularly those associated with the Battelle Library and the Defense Metals Information Center.

CONTENTS

	Page
ABSTRACT	ii
Section I. INTRODUCTION	1
Section II. FUNDAMENTAL INFORMATION ON DAMPING	2
Section III. METHODS OF MEASUREMENT	5
1. Torsional Pendulum	5
2. Resonant Systems	5
3. Ultrasonic Pulse	6
Section IV. SOME REPRESENTATIVE PROPERTIES	7
Section V. MECHANISMS OF DAMPING	10
Section VI. COMMENTS	11
LITERATURE CITED	35
Appendix A. SELECTED BIBLIOGRAPHY	37
Appendix B. SUBJECT INDEX	715
Appendix C. AUTHOR INDEX	737

ILLUSTRATIONS

Table		Page
I	Conversion of Logarithmic Decrement to Specific Damping Capacity (Percent) for Values 0.001 to 0.499 (After Jenson ²)	12
II	Conversion of Logarithmic Decrement to Specific Damping Capacity (Percent) for Values 0.01 to 1.99 (After Jenson ²)	13
III	Hardness, Strength, and Vibration Damping Capacity of Sand-Cast Magnesium Alloys, as Cast (After Walsh, et al., ¹¹)	14
IV	Hardness, Strength, and Vibration Damping Capacity of Some Commercial Materials (After Walsh, et al., ¹¹)	15
V	Hardness, Strength, and Vibration Damping Capacity of Heat-Treated, Sand-Cast Magnesium Alloys (After Walsh, et al., ¹¹)	16
VI	Hardness, Strength, and Vibration Damping Capacity of Wrought Magnesium Alloys (Extruded or Hot-Rolled) (After Walsh, et al., ¹¹)	17
VII	Hardness, Strength, and Vibration Damping Capacity of Heat-Treated Wrought Magnesium Alloys (After Walsh, et al., ¹¹)	18
VIII	Influence of Amplitude of Vibrations on Damping Capacity of Various Cast Irons (From Plenard ¹⁴)	19
IX	Influence of Method of Stressing on Damping Capacity of Specimens of Different Cast Irons (From Plenard ¹⁴)	20
X	Influence of Stress Relief Treatment on Damping Capacity of a Flake Graphite Iron (From Plenard ¹⁴)	21
XI	Influence of Cooling Rate on Solidification on Damping Capacity of Cast Irons (From Plenard ¹⁴)	22
Figure		
1	Hysteresis Loop in Stress-Strain Diagram (After Jenson ²)	23
2	Typical Resonance Peak, Showing Variation of Amplitude with Frequency at and near Resonance (After Jenson ²)	23

Figure		Page
3	A Simple Torsional Pendulum Useful at about 1 Cycle per Second in the Temperature Region around Room Temperature (After Wert ⁴)	24
4	Inverted Torsional Pendulum. The Entire Chamber can be Evacuated or Filled with an Inert Gas to Prevent Chemical Reaction in the Specimen. The Counterweight can be Adjusted to give an Arbitrarily Low Longitudinal Stress on the Specimen. (After Wert ⁴)	24
5	Schematic Diagrams of the Apparatus for Various High Frequency Methods of Measurement of Internal Friction (After Nowick ⁷)	25
6	Damping Capacities of Some Steels at 5,000 psi Surface Shear Stress (After Birchon ⁹)	26
7	Damping Capacities of Some Nonferrous Metals. Copper and Aluminum Alloys at 5,000 psi Shear Stress, Magnesium Alloys at 3,000 psi, Mallory Nochat and Nickel-Thoria at 10,000 psi. Nickel-Thoria Provided by International Nickel Co. (Mond) Ltd. (After Birchon ⁹)	26
8	Damping Capacities of Some Wrought Manganese-Copper Alloys, Heat-Treated for Maximum Damping Capacity, Measured at 5,000 psi Surface Shear Stress. Nitinol Measured at 10,000 psi; Nylon, 100 psi; Tufnol, 10 psi (After Birchon ⁹).	27
9	Damping Capacities of Some Cast Irons at 5,000 psi Surface Shear Stress. Samples Provided by B.C.I.R.A. (After Birchon ⁹)	27
10	Variation in Torsional Damping Capacity at 5,000 psi Surface Shear Stress, of 70/30 Manganese/Copper, Solution-Treated for Two Hours at 750°C, Water Quenched and Aged at 450°C for Two Hours, Followed by Water Quenching (After Birchon ⁹)	28
11	Damping Characteristics of Wrought, Cast, and APM Aluminum Alloys. Note how Alcladding Increases δ . (After Kaufman ¹⁰)	29
12	Low Strength Electrical Conductor Alloys have Significantly Greater Damping Capacity than Wrought Alloys (After Kaufman ¹⁰)	29

Figure		Page
13	Some Cast Magnesium Alloys have 10 to 20 Times more Damping Capacity than Wrought Aluminum Alloys (After Kaufman ¹⁰)	30
14	Cladding Increases the Damping Capacity of Aluminum Alloys. Cladding can be on One or Both Sides (After Kaufman ¹⁰)	30
15	Vibration Damping Capacity of Magnesium Alloys: A, As Cast; B, As Cast and Heat Treated (After Walsh, et al., ¹¹)	31
16	Vibration Damping Capacity of Magnesium Alloys: A, As Wrought; B, As Wrought and Heat Treated (After Walsh, et al., ¹¹)	32
17	Vibration Damping Capacity of Cast Magnesium and Selected Commercial Alloys (After Walsh, et al., ¹¹)	33
18	Damping Curves of Three Engineering Materials at Room Temperature (After Cochardt ¹²)	33
19	Vibration Damping Capacity Versus Stress, for the Same Specimen of a Magnesium Alloy, Varied by Prior Stressing (After Walsh, et al., ¹¹)	34

Section I. INTRODUCTION

While this bibliography was being compiled, a newly published damping of materials bibliography¹ covering the same time period was received by the Defense Metals Information Center of Battelle Memorial Institute. Upon examination, it was found that in spite of the similarity in subject and dates, hundreds of references gathered up to that point for this survey were not included. Similarly, hundreds of references in that bibliography had not been located for this one.

It was concluded that normally effective and fairly complete search procedures are apparently not adequate when some lesser known area of a particular subject is under scrutiny. Thus, while the present collection of references and abstracts is undoubtedly the most comprehensive available, it is not exhaustive.

References in this report are restricted to materials generally considered solid. Various glasses are included. References to liquids and liquid metals were avoided, as were discussions of viscosity (internal friction) of liquids or fluids in general. For the most part, the various relaxation phenomena associated with fundamental particles have also been avoided. Nuclear magnetic resonance, ferromagnetic resonance, and other such topics are not generally included. Sound absorption references in relation to acoustical engineering have been largely omitted. In some cases, these references were included because the absorption of sound waves can be used as a technique to study material damping properties. Although internal friction is a measure of the stress-strain relationships of a material, all of the massive literature on elastic moduli and mechanical properties has been avoided except in a few illustrative cases. Similarly, extensive areas of research in viscoelastic properties, particularly of plastics, are not cited.

Also avoided was most of the literature on damping caused by surface friction, such as in riveted joints. In addition, primarily for reasons of simplicity and usefulness, there are very few references to unpublished talks, or to cursory discussions of the subject in textbooks.

Section II. FUNDAMENTAL INFORMATION ON DAMPING

Internal friction or damping capacity is the ability of a material to absorb vibrational energy. The material must be considered in complete isolation from its surroundings.

Damping is an ancient and common property more familiar to the general reader than is generally assumed. For example, the flip of a coin to hear the ring was once a common test to distinguish the high-damping counterfeit from the low-damping legitimate coin. The ring of a crystal goblet also helps to distinguish the low damping of fine crystal from the high damping of the ordinary product.

High damping is a desirable property in many modern applications. In turbine buckets, in crankshafts, or in other devices where a part can resonate at some frequency, high damping tends to minimize the resonant amplitude, and thus minimizes the operating stresses to which the part is exposed. On the other hand, low damping may be required for proper functioning, as is the case with bells, tuning forks, and parts of musical instruments (piano strings, for example). Damping capacity is in fact a property of considerable industrial importance.

Another aspect of damping capacity--equal in importance to its industrial applications--is its value as an analytical tool in modern science. It is used to study diffusion, solubility, plastic deformation, alloy segregation, and a number of other physical and mechanical phenomena associated with material behavior. Therein lies a dichotomy dividing much of the literature on internal friction. A great deal of the literature discusses internal friction from the point of view of technological application (usually involving high stress environments) while most of the rest of the literature considers internal friction purely as a tool for the study of more fundamental phenomena (usually involving low stress environment). This double standard has led to a wide variety of testing methods, a rather complicated terminology, and a number of misunderstandings.

Basically, internal friction implies a deviation from perfect elasticity.² If a stress is applied to a specimen, and the strain is time-dependent or irreversible, then the stress-strain curve will enclose the area shown on Figure 1. This area, representing work done, can be referred to or represented in a variety of ways. Although there are some objections, the term "internal friction" appears to be generally accepted, as is "damping capacity." "Material damping" is perhaps a more descriptive term.

If a solid is vibrating freely, internal friction will cause a time-dependent decrease in the amplitude of the oscillation. One of the more common means of describing the damping is the logarithmic decrement (δ). This is the natural logarithm of the ratio of amplitudes one period of vibration apart. Thus,

$$\delta = \ln\left(\frac{A_n}{A_{n+1}}\right).$$

Because this ratio is close to unity where the damping is relatively low:

$$\left(\text{hence } \ln\left[\frac{A_n}{A_{n+1}}\right] \cong \left[\frac{A_n - A_{n+1}}{A_{n+1}}\right]\right)$$

the logarithmic decrement is also a measure of the relative loss of amplitude ΔA during one cycle of vibration

$$\delta = \frac{\Delta A}{A}$$

Because the energy of vibration is proportional to the square of the amplitude, it follows that the ratio of the energy dissipated per cycle (ΔW) to the total energy stored (U) is related to δ as:

$$2\delta = \frac{\Delta W}{U} = S.$$

This is true only for small values of δ . S is called the "specific loss" or the "specific damping capacity." It is frequently expressed in per cent. Therefore, both δ and S have easily visualizable meanings.

At higher losses, the approximations implied above do not hold, and S can differ appreciably from 2δ . Jenson² has put this relationship into a convenient tabular form, as shown in Tables I and II.

In many applications, internal friction is expressed as Q^{-1} , which is the logarithmic decrement divided by π . Q^{-1} is significant because it represents the tangent of the phase angle between stress and strain. Thus, for relatively low damping,

$$\delta = \frac{\Delta A}{A} = \frac{\Delta W}{2U} = \pi Q^{-1} .$$

However, damping is generally measured over a number of cycles:

$$\delta = \frac{\ln n}{F t}$$

where t is the time in seconds it takes for the amplitude to decrease to $1/n$ of its original amplitude at some frequency, F , in cycles per second.

Damping is also frequently measured during resonance under forced vibration. This is sometimes called the bandwidth method. In this case, the amplitude of the vibration depends upon the imposed frequency, as shown in Figure 2. The logarithmic decrement is related to the bluntness of the resonance peak. The logarithmic decrement is given by:

$$\delta = \frac{\pi \Delta F}{F_0}$$

where ΔF is the width of the resonance peak at an amplitude of $1/\sqrt{2}$ of the maximum amplitude.

Damping may also be measured by observing the decrease in amplitude of a wave as it passes through a solid body. If the amplitude at some point (A_x) is related to the initial amplitude (A_0) through the relation:

$$A_x = A_0 \exp (-\alpha x) ,$$

then α is called the attenuation coefficient.

Section III. METHODS OF MEASUREMENT

Internal friction or damping capacity can be measured by a variety of methods, many of which are described very thoroughly by Entwistle³ and Jenson². In the main, however, three general methods are employed. These methods are:

1. Torsional Pendulum
2. Resonant System
3. Ultrasonic Attenuation
(or Ultrasonic Pulse)

1. Torsional Pendulum

In the torsional pendulum method, the specimen forms the elastic member of the pendulum, as shown on Figure 3. The specimens are generally in the form of wire, but rectangular sections (e. g. , cut from a sheet) are often used. In general, an inertia member of such a moment as to cause a torsional frequency of 0.2 to 3 cycles per second is suspended from the end of the specimen. Observations of oscillation are often made by using an optical lever arm system. A mirror is attached to the inertia bar, and reflects a beam of light to a scale some meters distant. This permits oscillation of the pendulum to be observed under considerable magnification. In some instances, the load on the specimen is reduced by inverting the pendulum and compensating for the weight of the inertia bar, as shown in Figure 4. Various automated methods have been devised for such systems, among the best are those of Salvi, Dantreppe, and Friess.⁵ Specimens of large cross section are sometimes used so that frequencies of hundreds of cycles per second can be measured.²

2. Resonant Systems

In these systems the specimen, usually in the form of some simple geometric shape, such as a cylinder or right-angled prism, is set into oscillation at its own resonant frequency, and damping measurements can be made by observing the rate at which these oscillations decrease in amplitude once the driving force has stopped, or by measuring the width (in terms of driving frequency) of the resonance peak. Such systems generally operate in the kilocycle region of frequency.

Five different methods for exciting resonance are shown in Figure 5. Hinton⁶, for example, has used an electrostatic drive. Both Entwistle³ and Nowick⁷ have presented comprehensive reviews of the various methods in use. Almost any transducer can be utilized. For handling quantities of more engineering significance, even a commercial shaker-table can be used to induce resonance in a cantilever beam-type specimen.

3. Ultrasonic Pulse

Internal friction can also be measured by introducing a megacycle pulse into one end of a crystal, then measuring the attenuation in the amplitude of the reflected (or the transmitted) pulse. Of the three general methods, this is probably the most unsatisfactory at the moment for the measurement of internal friction. This is because so many different factors can be involved in the attenuation. Mason⁸ is one of the foremost advocates of this method.

Section IV. SOME REPRESENTATIVE PROPERTIES

An example of information available in these abstracts is presented here primarily to demonstrate that damping differs appreciably under different conditions and that care is often necessary in applying data to a real problem.

Birchon⁹ has collected information on a variety of materials. These data are shown on Figures 6 through 9. Data, such as these, though useful from a comparative point of view, are difficult to apply. This is because most damping is strongly dependent upon both the stress amplitude and the temperature at which it is taken. Figure 10, for example, shows the temperature dependence of a 70/30 manganese-copper alloy. While the damping is very high at zero, its usefulness as a high damping alloy at 100°C is most doubtful indeed.

The equal importance of stress amplitude is made abundantly clear by the data collected by Kaufman¹⁰ (Figures 11 through 14). This view is reinforced by the data of Walsh, Jenson, and Rowland¹¹, as shown in Tables 3 through 6, and Figures 15 through 17, and by data of Cochardt¹² on Figure 18.

Even within a single material, such as cast iron, many factors affect the damping. These include stress amplitude, method of stressing, stress relief treatment, and cooling rate, as shown in Tables 7 through 10. Stress history can also alter damping, as illustrated on Figure 16.

The engineering importance of damping capacity of non-metals is pointed out in the following excerpt from an article by H. Kolsky¹³. "The materials known as high polymers, which include plastics and rubbers, have mechanical properties very different from conventional engineering solids, and their increasing use in various structural applications has made the measurement of their properties a subject of growing importance, and one on which considerable experimental and theoretical effort is being exerted. The outstanding difference between the mechanical behavior of these materials and that of solids composed of smaller molecular units is the very much greater dependence of the former on the time of application of the stress. Thus, Young's modulus for a steel wire can be determined either by hanging a small weight on the end of the wire and measuring the extension or by measuring the velocity of propagation of longitudinal elastic waves along the wire. The values obtained from the two experiments would be found to differ by not more than one or two percent, even though

the stress cycle to which the material was subjected could have a duration of many hours in the hanging-weight experiment, and a duration of only a few millionths of a second in the wave propagation experiment. If the same two experiments were carried out with a filament of natural rubber, the two values of Young's modulus might be found to differ by a factor of perhaps a thousand, the "dynamic modulus" being very much greater than the "static." Similarly, the effect of temperature on the mechanical properties for a given rate of loading is many times greater for these high polymers than it is for crystalline materials such as metals. Thus, the value of Young's modulus for platinum changes by about one part in a thousand for a change in temperature of one-degree centigrade, while the modulus of a plastic can change by 10 to 20 per cent per degree centigrade."

Another difference between the mechanical properties of polymers and other solids is the very much larger internal friction exhibited by polymeric materials. Internal friction may be defined in a number of ways, but the most direct definition is in terms of the "specific loss" or, as it is sometimes called, the "specific damping capacity". When a specimen of a solid is taken round a stress cycle, a certain amount of hysteresis is always present, the stress-strain curve for decreasing stress always differing slightly from that for increasing stress. This hysteresis corresponds to the dissipation of mechanical energy during the stress cycle, and the specific loss is defined as the ratio $\Delta W/W$, where ΔW is the energy dissipated in the cycle and W is the elastic energy stored in the specimen when the strain is a maximum. The value obtained for a given specimen is found to vary with the speed of the cycle and often also with the amplitude, although for small stresses the specific loss is generally insensitive to amplitude.

Internal friction may be defined in a number of other ways, for example, as the logarithmic decrement of free vibrations of a mechanical system, where a specimen of material under investigation provides the restoring elastic element, or alternatively as the sharpness of resonance of such a system. At high frequencies, the attenuation of stress waves propagated through the material provides yet another method of measuring internal friction and, so long as the value of $\Delta W/W$ is small compared with unity, it may be shown that all these different definitions are mathematically related to each other, and measurements made on any one material by different methods have been found experimentally to be in good agreement with one another.

For crystalline materials, very low values of the specific loss $\Delta W/W$ have been observed; thus, for a quartz ring, values as low as 3×10^{-6} and, for ordinary polycrystalline metals, values between 10^{-3} and 10^{-4} are common. With polymers, however, especially when they are in the rubber-like state, the value of the specific loss can be as large as 0.5.

The mechanical properties of an isotropic elastic solid are defined once two quantities (Young's modulus and Poisson's ratio) are known. The temperature coefficient of these quantities may also be needed if considerable temperature variations are expected, but for most engineering applications it is possible to ignore changes of modulus with temperature and to regard the elastic constants as temperature independent. For high polymers, the situation is quite different, and to assign a modulus to these materials without specifying the rate of application of the load and the temperature is quite meaningless. Instead of two numbers, a series of curves, which will give the modulus and the specific loss for different rates of loading at a series of temperatures, is necessary before the mechanical behavior of these materials is defined. A considerable amount of experimental work is consequently required to specify the mechanical behavior of such materials, even where only small deformations are involved. Thus, in an investigation of the dynamic mechanical properties of a single high polymer, polyisobutylene, which was undertaken as a joint venture by twenty-seven different laboratories a few years ago, it is estimated that one hundred man-years of research were expended.

Section V. MECHANISMS OF DAMPING

It is not possible at this time to begin a detailed discussion of the mechanisms responsible for damping. During the course of the search, however, several excellent reviews were encountered, and these are listed here for the convenience of those who wish to dig deeper.

K. M. Entwistle,
THE INTERNAL FRICTION OF METALS, Metallurgical Reviews,
Vol. 7, 1962, pp. 175-239.

R. W. B. Stephens,
THE APPLICATIONS OF DAMPING CAPACITY FOR INVESTIGATING THE STRUCTURE OF SOLIDS, paper from Progress in Nondestructive Testing, Heywood and Co., Ltd., London, England, 1958, Vol. 1, pp. 167-198.

A. E. Woodward,
MECHANICAL RELAXATION PHENOMENA, paper from Physics and Chemistry of the Organic Solid State, Vol. II, 1965, edited by D. Fox, M. M. Labes, and A. Wersberger, Interscience Publishers, pp. 637-723.

D. H. Niblett and J. Wilks,
DISLOCATION DAMPING IN METALS, Advances in Physics,
1960, Vol. 9, pp. 1-88.

A. Cochardt,
MAGNETOMECHANICAL DAMPING, Proceeding, Magnetic Properties of Metals and Alloys, American Society for Metals, Novelty, Ohio, 1959, pp. 251-279.

K. M. Entwistle,
THE DAMPING CAPACITY OF METALS, paper from the Physical Examination of Metals, edited by Bruce Chalmers and A. G. Quarrell, London, England, Edward Arnold, Ltd., 1960, pp. 487-558.

Section VI. COMMENTS

It has become clear during the conduct of this search that there is much communication lacking in the field of damping. It is exceedingly difficult to find out what is available, even when, in some cases, it is readily available. This is in part because damping is only now being recognized as an important mechanical property. Even now, however, appropriate data are being filed (or misfiled) under such a variety of names that even a search in depth has no assurance of uncovering fairly large masses of significant data. Further, much of what is presumed to be pertinent data remains untranslated in a variety of foreign tongues for years after it is generated. The time is ripe, it would seem, to do something about this problem. Specifically, we would like to suggest the following.

- 1) That surveys in depth of the damping of specific materials or classes of materials (mild steel, or Invar, or high damping metals, for example) be undertaken. These would collect and tabulate data from all available sources.
- 2) That these survey funds be augmented by small but significant experimental funds so that some of the more obvious gaps in the literature can be filled. (There are, for example, virtually no engineering data on the damping of 304 stainless, or on Ni Span C, or beryllium.)
- 3) That these surveys in depth be so constituted that data forthcoming subsequent to publication can be conveniently added to the earlier data.

These surveys, by placing available data at the fingertips of the engineers and designers by whom they would be used, would serve in no small way to both emphasize the importance of damping in modern engineering and to ensure that what is known is used.

Table I. Conversion of Logarithmic Decrement to Specific Damping Capacity (Percent) for Values 0.001 to 0.499 (After Jenson²)

	Specific damping capacity, percent									
	0	1	2	3	4	5	6	7	8	9
0.00		0.200	0.399	0.598	0.797	0.995	1.193	1.390	1.587	1.784
.01	1.980	2.176	2.371	2.566	2.761	2.955	3.149	3.343	3.536	3.729
.02	3.921	4.113	4.305	4.496	4.687	4.877	5.067	5.257	5.446	5.635
.03	5.824	6.012	6.200	6.387	6.574	6.761	6.947	7.133	7.318	7.504
.04	7.688	7.873	8.057	8.241	8.424	8.607	8.790	8.972	9.154	9.335
.05	9.517	9.697	9.877	10.058	10.237	10.417	10.596	10.774	10.952	11.130
.06	11.308	11.485	11.662	11.839	12.015	12.190	12.365	12.541	12.716	12.890
.07	13.064	13.237	13.411	13.584	13.757	13.929	14.101	14.273	14.444	14.615
.08	14.786	14.956	15.126	15.295	15.464	15.634	15.802	15.970	16.138	16.306
.09	16.473	16.640	16.806	16.973	17.139	17.304	17.469	17.634	17.799	17.963
.10	18.127	18.291	18.454	18.617	18.779	18.942	19.104	19.265	19.427	19.587
.11	19.749	19.908	20.069	20.228	20.388	20.547	20.705	20.864	21.022	21.180
.12	21.337	21.494	21.651	21.808	21.964	22.120	22.276	22.431	22.586	22.740
.13	22.895	23.049	23.203	23.356	23.509	23.662	23.815	23.967	24.119	24.270
.14	24.422	24.573	24.723	24.874	25.024	25.174	25.323	25.472	25.621	25.770
.15	25.918	26.066	26.214	26.361	26.508	26.655	26.802	26.948	27.094	27.240
.16	27.385	27.530	27.674	27.817	27.964	28.108	28.251	28.395	28.538	28.680
.17	28.823	28.965	29.107	29.249	29.390	29.531	29.671	29.813	29.953	30.093
.18	30.232	30.372	30.511	30.650	30.788	30.927	31.065	31.202	31.340	31.477
.19	31.614	31.750	31.887	32.023	32.159	32.294	32.430	32.565	32.699	32.834
.20	32.968	33.102	33.236	33.369	33.502	33.635	33.768	33.900	34.032	34.164
.21	34.295	34.427	34.558	34.688	34.819	34.949	35.079	35.209	35.338	35.467
.22	35.596	35.725	35.853	35.982	36.110	36.237	36.365	36.492	36.619	36.745
.23	36.872	36.998	37.124	37.249	37.375	37.500	37.625	37.749	37.874	37.998
.24	38.122	38.245	38.369	38.492	38.615	38.738	38.860	38.982	39.104	39.226
.25	39.347	39.468	39.589	39.710	39.830	39.950	40.070	40.190	40.310	40.429
.26	40.548	40.667	40.785	40.904	41.022	41.140	41.257	41.374	41.492	41.609
.27	41.725	41.842	41.958	42.074	42.190	42.305	42.420	42.535	42.650	42.765
.28	42.879	42.993	43.107	43.221	43.334	43.447	43.560	43.673	43.786	43.898
.29	44.010	44.122	44.234	44.345	44.456	44.567	44.678	44.789	44.899	45.009
.30	45.119	45.228	45.338	45.447	45.556	45.665	45.773	45.882	45.990	46.098
.31	46.206	46.313	46.420	46.527	46.634	46.741	46.847	46.953	47.059	47.165
.32	47.271	47.376	47.481	47.586	47.691	47.795	47.900	48.004	48.108	48.211
.33	48.315	48.418	48.521	48.624	48.727	48.829	48.931	49.033	49.135	49.237
.34	49.338	49.440	49.541	49.641	49.742	49.842	49.943	50.043	50.142	50.242
.35	50.341	50.441	50.540	50.638	50.737	50.836	50.934	51.032	51.130	51.227
.36	51.325	51.422	51.519	51.616	51.713	51.809	51.905	52.002	52.099	52.194
.37	52.289	52.384	52.479	52.574	52.669	52.763	52.858	52.952	53.046	53.140
.38	53.233	53.327	53.420	53.513	53.605	53.699	53.791	53.884	53.976	54.068
.39	54.159	54.251	54.342	54.434	54.525	54.616	54.706	54.797	54.887	54.977
.40	55.067	55.157	55.246	55.336	55.425	55.514	55.603	55.692	55.780	55.869
.41	55.957	56.045	56.133	56.220	56.308	56.395	56.482	56.569	56.656	56.743
.42	56.829	56.915	57.001	57.087	57.173	57.259	57.344	57.429	57.514	57.599
.43	57.684	57.768	57.853	57.937	58.021	58.105	58.189	58.272	58.355	58.439
.44	58.522	58.605	58.687	58.770	58.852	58.934	59.016	59.098	59.180	59.262
.45	59.343	59.425	59.505	59.586	59.666	59.748	59.828	59.908	59.988	60.068
.46	60.148	60.228	60.307	60.386	60.466	60.545	60.623	60.702	60.781	60.859
.47	60.937	61.016	61.093	61.171	61.248	61.326	61.404	61.480	61.557	61.634
.48	61.711	61.787	61.864	61.940	62.016	62.092	62.167	62.243	62.319	62.394
.49	62.469	62.544	62.619	62.693	62.768	62.842	62.917	62.991	63.065	63.138

Table II. Conversion of Logarithmic Decrement to Specific Damping Capacity (Percent)
for Values 0.01 to 1.99 (After Jenson²)

Specific damping capacity, percent										
	0	1	2	3	4	5	6	7	8	9
0.0		1.98	3.92	5.82	7.69	9.52	11.31	13.07	14.79	16.47
.1	18.13	19.75	21.34	22.90	24.42	25.92	27.39	28.82	30.23	31.61
.2	32.97	34.30	35.60	36.87	38.12	39.35	40.55	41.73	42.88	44.01
.3	45.12	46.21	47.27	48.32	49.34	50.34	51.33	52.29	53.23	54.16
.4	55.07	55.96	56.83	57.68	58.52	59.34	60.15	60.94	61.71	62.47
.5	63.21	63.94	64.65	65.35	66.04	66.71	67.37	68.02	68.65	69.27
.6	69.88	70.48	71.06	71.63	72.20	72.74	73.29	73.82	74.33	74.84
.7	75.34	75.83	76.31	76.78	77.24	77.69	78.13	78.56	78.99	79.40
.8	79.81	80.21	80.60	80.99	81.36	81.73	82.09	82.45	82.80	83.14
.9	83.47	83.80	84.12	84.43	84.74	85.04	85.34	85.63	85.91	86.19
1.0	86.47	86.73	87.00	87.25	87.51	87.75	88.00	88.23	88.47	88.70
1.1	88.92	89.14	89.35	89.56	89.77	89.97	90.17	90.37	90.56	90.74
1.2	90.93	91.11	91.28	91.46	91.63	91.79	91.95	92.11	92.27	92.42
1.3	92.57	92.72	92.86	93.01	93.14	93.28	93.41	93.54	93.67	93.80
1.4	93.92	94.04	94.16	94.27	94.39	94.50	94.61	94.71	94.82	94.92
1.5	95.02	95.12	95.22	95.31	95.40	95.50	95.58	95.67	95.76	95.84
1.6	95.92	96.00	96.08	96.16	96.24	96.31	96.38	96.46	96.53	96.60
1.7	96.66	96.73	96.79	96.86	96.92	96.98	97.04	97.10	97.16	97.21
1.8	97.27	97.32	97.37	97.43	97.48	97.53	97.58	97.62	97.67	97.72
1.9	97.76	97.81	97.85	97.89	97.93	97.98	98.02	98.06	98.09	98.13

Table III. Hardness, Strength, and Vibration Damping Capacity of Sand-Cast Magnesium Alloys, as Cast (After Walsh, et al.,¹¹)

Alloy No.	Commercial designation	Composition, ¹ percent	Rockwell hardness	Yield strength (0.2 pct offset), 1,000 psi	Tensile strength, 1,000 psi	Specific damping capacity, percent, at stress levels--					
						500 psi	1,000 psi	1,500 psi	2,000 psi	2,500 psi	3,500 psi
D17 . .	K1-F	0.6 Zr	19 E	6.8	22.0	49	61	65	67	69	72
D36 . .	K1X1-F	0.6 Zr	12 E	6.5	21.6	56	67	71	72	73	75
D21 . .	S1-F	0.7 Si	39 E	7.6	13.5	44	55	61	66	70	75
D39 . .	S1	1.4 Si	40 E	8.7	15.5	34	43	49	58	62	67
4060 .	-	0.2 Si	49 H	-	10.3	51	63	(²)	-	-	-
D22 . .	M1-F	0.9 Mn	44 H	2.5	13.5	43	63	80	87	89	91
D38 . .	M1	1.4 Mn	51 H	-	10.8	46	85	(³)	-	-	-
D40 . .	AM100A-F	9.8 Al, 0.2 Mn	74 E	17.2	21.0	.044	.099	1.5	8.0	16	34
4059 .	-	8.6 Li, 0.5 Si	30 E	-	-	1.9	2.3	2.9	4.6	7.9	16

¹ Nominal.

² Modulus too low for sensitivity of test.

³ Severe plastic flow.

Table IV. Hardness, Strength, and Vibration Damping Capacity of Some Commercial Materials
(After Walsh, et al.,¹¹)

Alloy No.	Commercial designation	Composition, ¹ percent	Hardness ²	Yield strength (0.2 pct offset), 1,000 psi	Tensile strength, 1,000 psi	Specific damping capacity, percent, at stress levels--					
						500 psi	1,000 psi	1,500 psi	2,000 psi	2,500 psi	3,500 psi
1 . . .	Cast Mg	99.9 Mg	30 R _H	3.0	10.0	73	89	(³)	-	-	-
2 . . .	Aluminum 2S-F	99. Al	38 Bhn	17.0	20.0	-	.22	0.28	-	0.46	0.68
3 . . .	Al Alloy 11S-T3	5.5 Cu, 0.5 Pb, 0.5 Bi	95 Bhn	47.0	53.0	-	.08	.10	-	.15	.19
4 . . .	Al Alloy 17S-T4	4 Cu, 0.5 Mg, 0.5 Mn	105 Bhn	40.0	62.0	-	.022	.022	-	.022	.023
5 . . .	Al Alloy 24S-T4	4.5 Cu, 1.5 Mg, 0.6 Mn	120 Bhn	46.0	68.0	-	.025	.026	-	.027	.029
6 . . .	Free-Cutting brass, 1/2 H	62 Cu, 35 Zn, 3 Pb	75 R _B	44.0	55.0	-	.14	.18	-	.28	.42
7 . . .	Naval brass, 1/4 H	60 Cu, 39 Zn, 1 Sn	78 R _B	46.0	69.0	-	.015	.015	-	.016	.017
8 . . .	Gray cast iron	3.5 C, 0.3 P, 2 Si, 0.5 Mn	205 Bhn	-	36.0	-	4.1	5.3	-	7.5	9.3

¹ Nominal.

² R_H, Rockwell H scale; Bhn, Briuel number; R_B, Rockwell B Scale.

³ Severe plastic flow.

Table V. Hardness, Strength, and Vibration Damping Capacity of Heat-Treated, Sand-Cast Magnesium Alloys (After Walsh, et al.,¹¹)

Alloy No.	Commercial designation	Composition, ¹ percent	Rockwell hardness	Yield Strength (0.2 pct offset), 1,000 psi	Tensile strength, 1,000 psi	Specific damping capacity, percent at stress levels--					
						500 psi	1,000 psi	1,500 psi	2,000 psi	2,500 psi	3,500 psi
D9...	AZ91C-T4	9 Al, 1 Zn, 0.4 Mn	66 E	13.4	32.0	-	0.017	0.14	0.55	1.8	11
D10..	AZ91C-T6	9 Al, 1 Zn, 0.4 Mn	78 E	17.0	32.0	0.042	.058	.12	.50	1.9	9.3
D11..	AZ81XA-T4	8 Al, 1 Zn, 0.2 Mn	63 E	13.3	35.5	.003	.008	.025	.18	1.8	10
D12..	EK41A-T5	4 Ce, 0.7 Zr	66 E	17.2	20.0	1.0	1.6	2.1	2.7	3.4	5.4
D13..	EK41A-T6	4 Ce, 0.7 Zr	68 E	18.6	22.6	.34	.51	.71	.94	1.2	1.8
D14..	EZ33A-T5	3 Ce, 3 Zn, 0.7 Zr	66 E	15.3	19.0	.26	1.6	4.4	7.9	12	19
D15..	HK31A-T6	3 Th, 0.7 Zr	67 E	16.0	28.0	.28	.37	.48	.62	.83	1.4
D16..	ZH62XA-T5	6 Zn, 2 Th	80 E	25.0	32.8	.11	.12	.13	.14	.14	.17
D18..	EK30A-T6	3 Ce, 0.4 Zr	59 E	14.5	18.4	.88	1.2	1.6	2.2	3.2	6.9
D19..	AZ92A-T6	9 Al, 2 Zn, 0.2 Mn	83 E	18.8	29.0	.006	.028	.11	.36	1.2	6.6
D20..	HZ32XA-T5	3 Th, 2 Zn, 0.7 Zr	66 E	15.7	25.0	.45	1.9	4.4	7.6	11	17
D37..	K1X1-T4	0.6 Zr	5 E (56 H)	6.9	22.5	53	67	72	73	73	74

¹ Nominal.

Table VI. Hardness, Strength, and Vibration Damping Capacity of Wrought Magnesium Alloys
(Extruded or Hot-Rolled) (After Walsh, et al.,¹¹)

Alloy No.	Commercial designation	Composition, ¹ percent	Rockwell hardness	Yield strength (0.2 pct offset), 1,000 psi	Tensile strength, 1,000 psi	Specific damping capacity, percent, at stress levels --					
						500 psi	1,000 psi	1,500 psi	2,000 psi	2,500 psi	3,500 psi
D1 . . .	AZ80A-F	8 Al, 0.5 Zn, 0.2 Mn	77 E	34.0	50.0	-	0.035	0.040	0.075	0.16	0.62
D3 . . .	AZ61A-F	6 Al, 1 Zn, 0.2 Mn	76 E	34.5	48.0	0.032	.036	.040	.052	.073	.15
D4 . . .	AZ31B	3 Al, 1 Zn, 0.3 Mn	60 E	27.0	40.0	-	.030	.096	2.5	5.3	13
D5 . . .	ZK60A-F	5.5 Zn, 0.6 Zr	80 E	38.0	48.0	.10	.10	.10	.11	.11	.13
D23 . .	AZ31B	3 Al, 1 Zn, 0.3 Mn	52 E	19.4	35.6	-	.48	3.6	11	18	31
D24 . .	AZ31B	3 Al, 1 Zn, 0.3 Mn	48 E	20.3	36.3	-	.32	3.2	9.3	16	28
D25 . .	AZ31B	3 Al, 1 Zn, 0.3 Mn	52 E	-	-	-	.73	5.1	13	23	37
D26 . .	AZ31B	3 Al, 1 Zn, 0.3 Mn	52 E	-	-	-	.62	4.3	12	22	36
D31 . .	AZ31B	3 Al, 1 Zn, 0.3 Mn	56 E	-	-	-	.33	1.3	5.4	8.0	21
D32 . .	-	1 Zn, 0.7 Zr	43 E	32.0	34.0	-	.55	.99	1.9	2.9	7.3
D41 . .	HM31XA	3 Th, 1 Mn	74 E	45.0	48.0	.65	.70	.85	1.3	1.6	2.6

¹ Nominal.

Table VII. Hardness, Strength, and Vibration Damping Capacity of Heat-Treated Wrought Magnesium Alloys (After Walsh, et al., ¹¹)

Alloy No.	Commercial designation	Composition, ¹ percent	Rockwell hardness	Yield strength (0.2 pct offset), 1,000 psi	Tensile strength 1,000 psi	Specific damping capacity, percent, at stress levels--					
						500 psi	1,000 psi	1,500 psi	2,000 psi	2,500 psi	3,500 psi
D2...	AZ80Z-T5	8 Al, 0.5 Zn, 0.2 Mn	86 E	41.4	52.0	0.076	0.11	0.16	0.24	0.35	0.70
D6...	ZK60A-T5	5.5 Zn, 0.6 Zr	82 E	40.6	49.0	0.11	0.12	0.12	0.12	0.12	0.14
D42..	HM21XA-T5	2 Th, 0.5 Mn	67 E	24.8	34.5	0.10	0.24	0.34	0.65	0.88	1.4
D1...	AZ80A ²	8 Al, 0.5 Zn, 0.2 Mn	84 E	-	-	0.065	0.074	0.088	0.10	0.13	0.18
D3...	AZ61A ²	6 Al, 1 Zn, 0.2 Mn	77 E	-	-	0.030	0.032	0.036	0.042	0.050	0.069
D4...	AZ31B ²	3 Al, 1 Zn, 0.3 Mn	62 E	-	-	0.022	0.10	0.36	1.0	2.4	5.2

¹ Nominal.

² Heat treated: 3 hours at 250° C.

Table VIII. Influence of Amplitude of Vibrations on Damping Capacity of Various Cast Irons (From Plenard¹⁴)

Type of iron	Specimen No.	Amplitude (arbitrary units)	Damping capacity $\delta \times 10^4$	
			(1)	(3)
Spheroidal graphite iron	183	0.1	9.1	4.8
		0.16	9.3	5.2
		0.25	9.3	6.0
		0.5	9.3	—
		0.71	—	6.3
		0.9	9.4	—
Fine Flake graphite iron	451	0.1	28.0	45.3
		0.16	28.0	45.3
		0.25	28.5	45.3
		0.5	29.0	53.0
		0.7	30.0	60.0
Coarser flake graphite iron	60	0.1	120	59
		0.16	125	61
		0.5	125	62.5
		0.9	130	80
(1) Measurements made for damped longitudinal vibrations.				
(3) Measurements made for damped transverse vibrations.				

Table IX. Influence of Method of Stressing on Damping Capacity of Specimens of Different Cast Irons (From Plenard¹⁴)

Type of iron	Specimen No.	Frequency, c/s	Damping Capacity $\delta \times 10^4$	
			longitudinal vibrations (2)	transverse vibrations (4)
Spheroidal graphite iron	147	{ 19, 120 1, 686	4.7	4.3
	148	{ 19, 511 1, 721	5.6	5.3
	149	{ 19, 475 1, 713	6.5	6.4
Flake graphite iron	427	{ 13, 150 753	251	193
	428	{ 12, 409 704	544	384
	429	{ 12, 275 707	647	426

(2) Maintained longitudinal vibrations.

(4) Maintained transverse vibrations.

Table X. Influence of Stress Relief Treatment on Damping Capacity of a Flake Graphite Iron (From Plenard¹⁴)

Specimen No.	Damping Capacity $\delta \times 10^4$		
	(2)	(4)	
419 twice	{ before treatment	64.4	75.3
	{ after treatment	51.0	48.2
419 twice	{ before treatment	72.1	77.2
	{ after treatment	57.5	58.2
420 twice	{ before treatment	59.9	73.2
	{ after treatment	47.5	48.4
421 twice	{ before treatment	162	187
	{ after treatment	60.7	63.4
(2) Maintained longitudinal vibrations.			
(4) Maintained transverse vibrations.			

Table XI. Influence of Cooling Rate on Solidification on Damping Capacity of Cast Irons (From Plenard¹⁴)

Type of iron	Specimen No.	Diameter of cast bars		Damping capacity $\delta \times 10^4$			
		mm	in.	(1)	(2)	(3)	(4)
Coarse flake graphite iron	424	6	0.24	21.7	11.4	14.2	-
	425	10	0.39	108	30.6	45.0	-
	426	15	0.59		103	150	97
	427	22	0.87		251	330	193
	428	30	1.28		544	770	384
	429	50	1.95		647		426
Fine flake graphite iron	86	22	0.87		18	30	23
	87	32	1.25		63	90	65
	88	50	1.95		90	90	68
Spheroidal graphite iron	141	22	0.87	8.1	5.6	5.4	5.3
	142	32	1.25	11.1	6.5	8.4	5.3
	143	50	1.95	8.8	6.5	6.7	5.2
Ferritic spheroidal graphite iron treated with sintered Fe-Mg	134	10	0.39	20	9	10	8
	135	15	0.59	20	10	12	8
	136	22	0.87	29	13	17	11
	137	32	1.25	29	13	17	11
Flake graphite iron inoculated	550	15	0.59			24.7	12.0
	551	22	0.87			38.5	16.7
with Si	553	50	1.95			41.5	16.6
Flake graphite iron inoculated with Si-Mn-Zr	554	10	0.39			17.2	10.6
	555	15	0.59			28.6	12.9
	556	22	0.87			34.5	14.8
	558	50	1.95			36.0	16.9
Flake graphite iron inoculated with Si-Ca	559	15	0.59			25.3	11.2
	560	22	0.87			26.3	13.6
	561	32	1.25			38.0	18.1
	562	50	1.95				27.4
Flake graphite iron inoculated with Fe-Si, Si-Ca and Si-Mn-Zr	563	15	0.59			26.0	12.3
	564	22	0.87			30.5	13.7
	565	32	1.25			29.4	14.3
	566	50	1.95			66.5	26.4
Flake graphite iron for comparison	89	22	0.87		48	65	46
	90	32	1.25		71	80	56
	91	50	1.95		102	125	103
Flake graphite iron treated with Zr	92	22	0.87		56	75	51
	93	32	1.25		93	110	77
	94	50	1.95		112	180	105
Flake graphite iron bubbled with nitrogen	54	22	0.87	77			
	55	50	1.95		45.8		
Recarburized ingot mold iron	118	32	1.25		47.1		
	119	150	5.90		116		

(1) Measurements made for damped longitudinal vibrations.
(2) Measurements made for maintained longitudinal vibrations.
(3) Measurements made for damped transverse vibrations.
(4) Measurements made for maintained transverse vibrations.

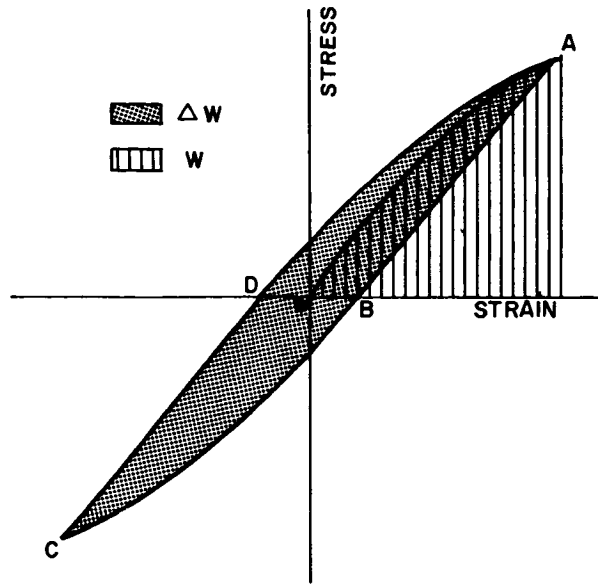

Figure 1. Hysteresis Loop in Stress-Strain Diagram (After Jenson²)

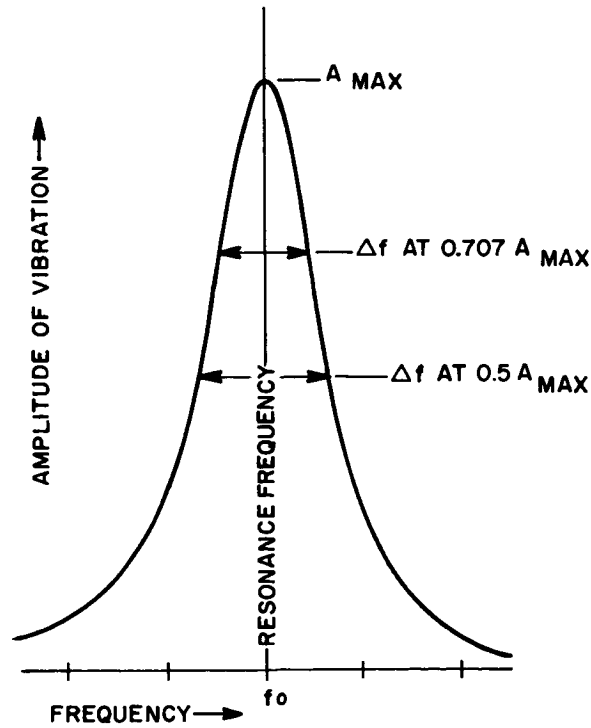

Figure 2. Typical Resonance Peak, Showing Variation of Amplitude with Frequency at and near Resonance (After Jenson²)

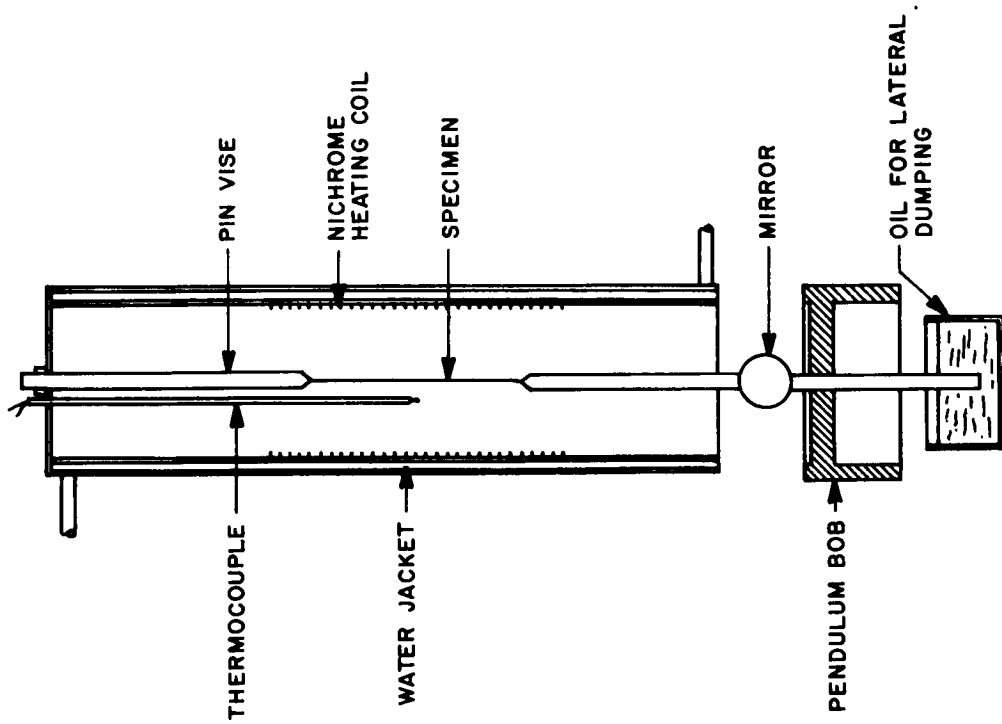

Figure 3. A Simple Torsional Pendulum Useful at about 1 Cycle per Second in the Temperature Region around Room Temperature (After Wert⁴)

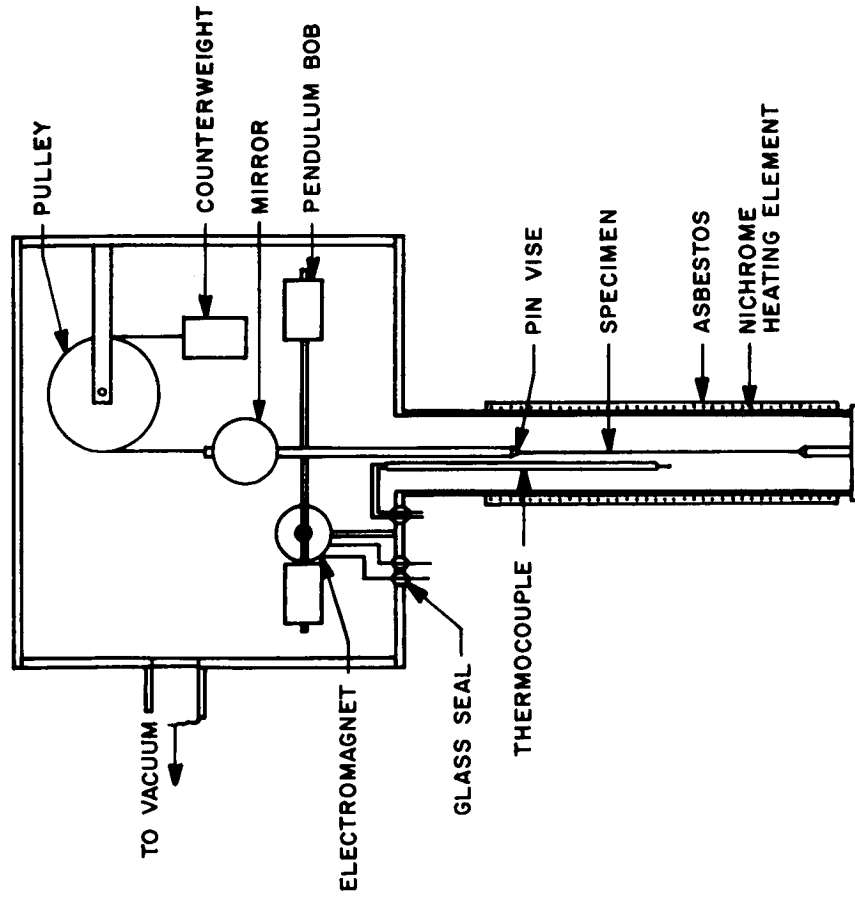

Figure 4. Inverted Torsional Pendulum. The Entire Chamber can be Evacuated or Filled with an Inert Gas to Prevent Chemical Reaction in the Specimen. The Counterweight can be Adjusted to give an Arbitrarily Low Longitudinal Stress on the Specimen. (After Wert⁴)

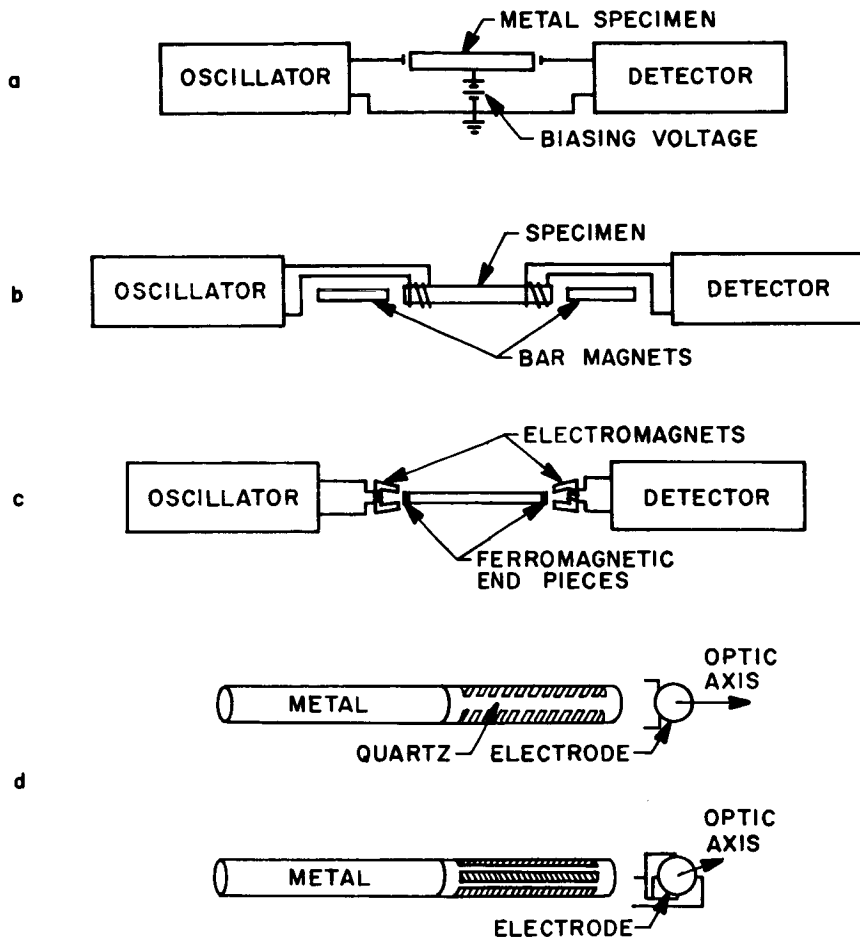

Figure 5. Schematic Diagrams of the Apparatus for Various High Frequency Methods of Measurement of Internal Friction (After Nowick⁷)

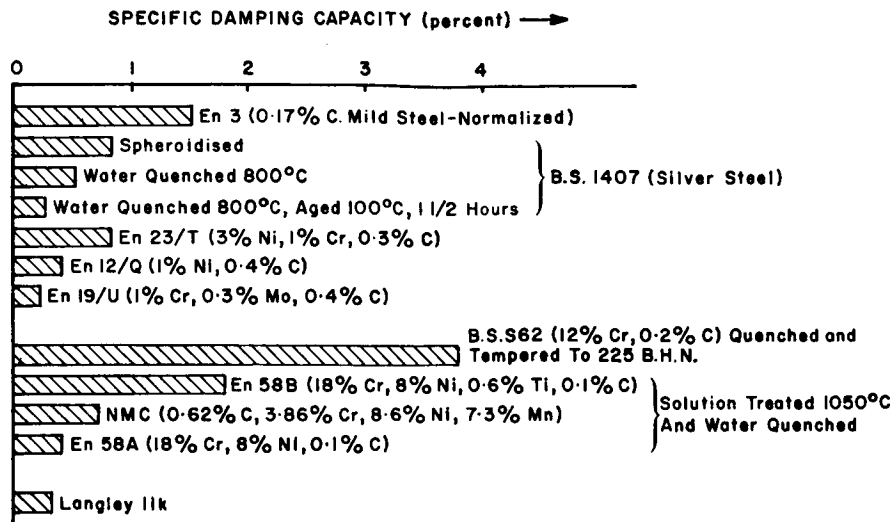

Figure 6. Damping Capacities of Some Steels at 5,000 psi Surface Shear Stress (After Birchon⁹)

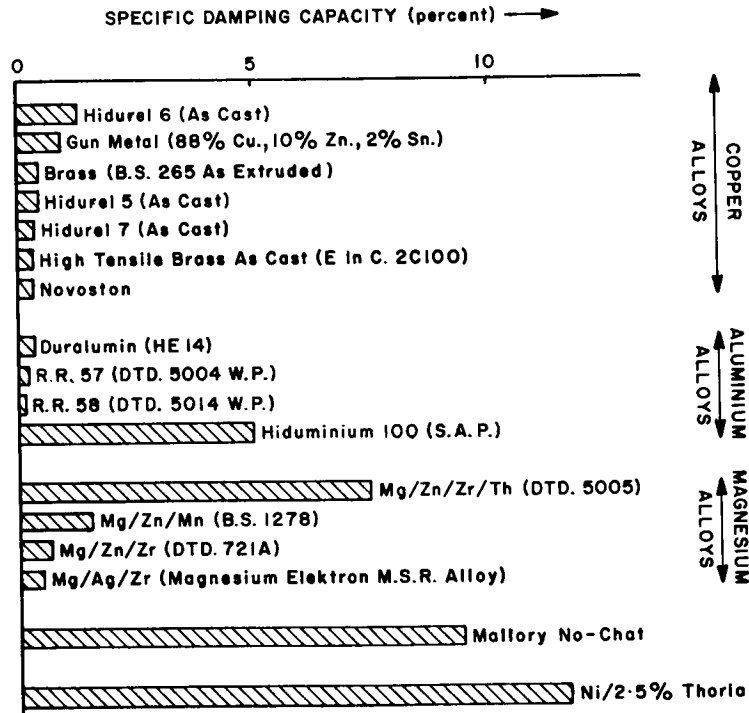

Figure 7. Damping Capacities of Some Non-ferrous Metals. Copper and Aluminum Alloys at 5,000 psi Shear Stress, Magnesium Alloys at 3,000 psi, Mallory Nochat and Nickel-Thoria at 10,000 psi. Nickel-Thoria Provided by International Nickel Co. (Mond) Ltd. (After Birchon⁹)

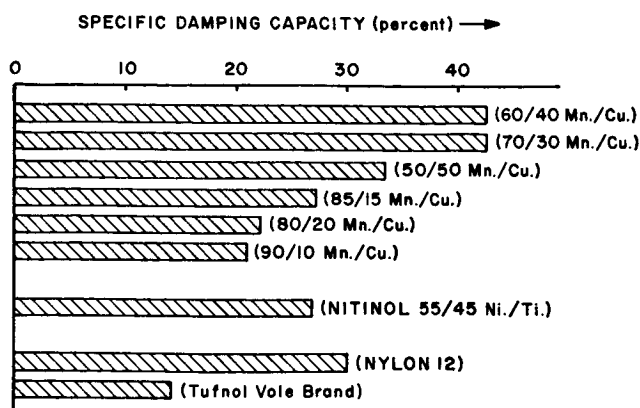

Figure 8. Damping Capacities of Some Wrought Manganese-Copper Alloys, Heat-Treated for Maximum Damping Capacity, Measured at 5,000 psi Surface Shear Stress. Nitinol Measured at 10,000 psi; Nylon, 100 psi; Tufnol, 10 psi (After Birchon⁹)

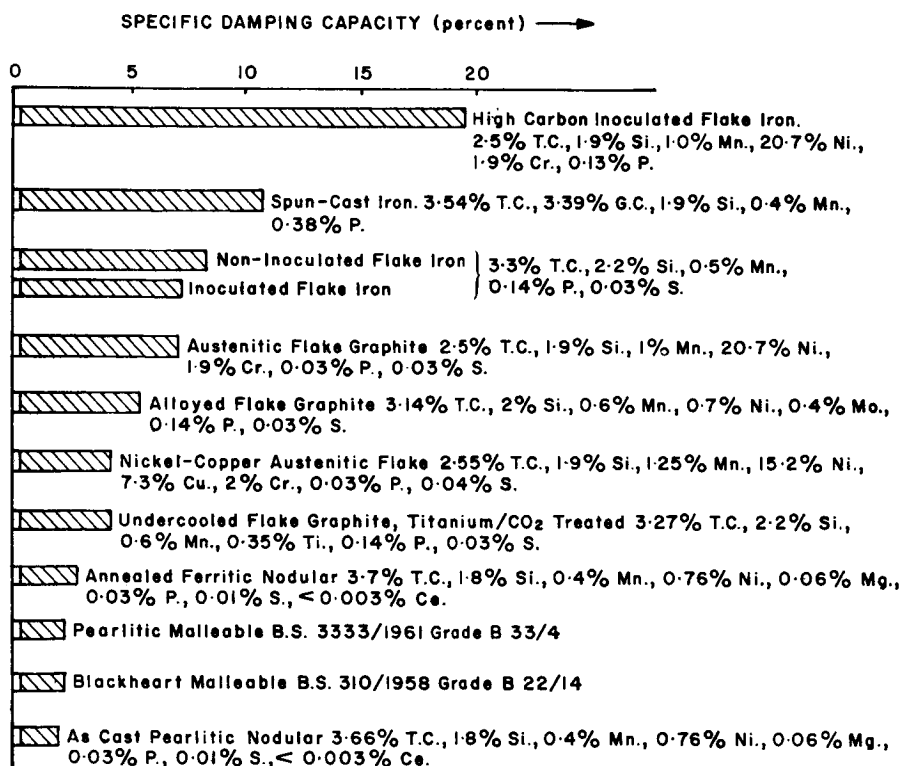

Figure 9. Damping Capacities of Some Cast Irons at 5,000 psi Surface Shear Stress. Samples Provided by B.C.I.R.A. (After Birchon⁹)

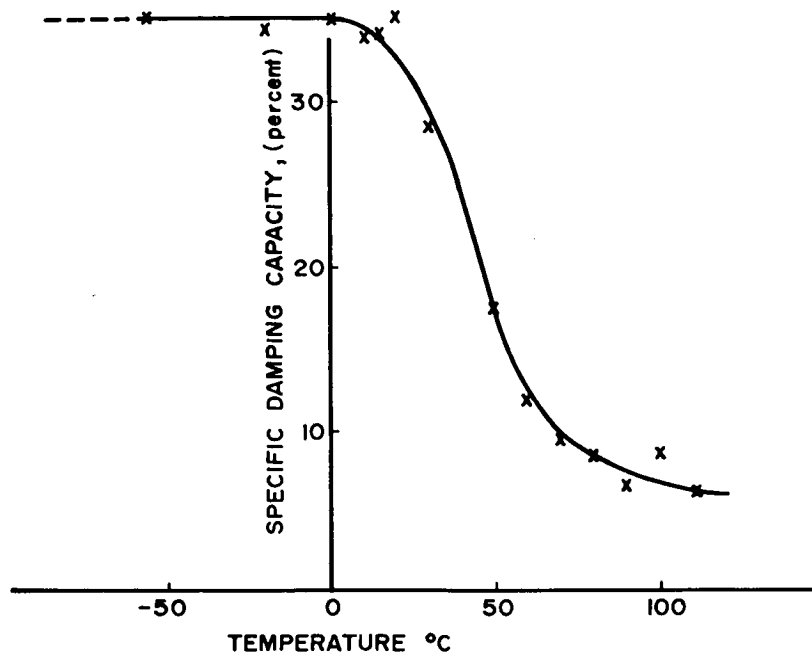

Figure 10. Variation in Torsional Damping Capacity at 5,000 psi Surface Shear Stress, of 70/30 Manganese/Copper, Solution-Treated for Two Hours at 750°C, Water Quenched and Aged at 450°C for Two Hours, Followed by Water Quenching (After Birchon⁹)

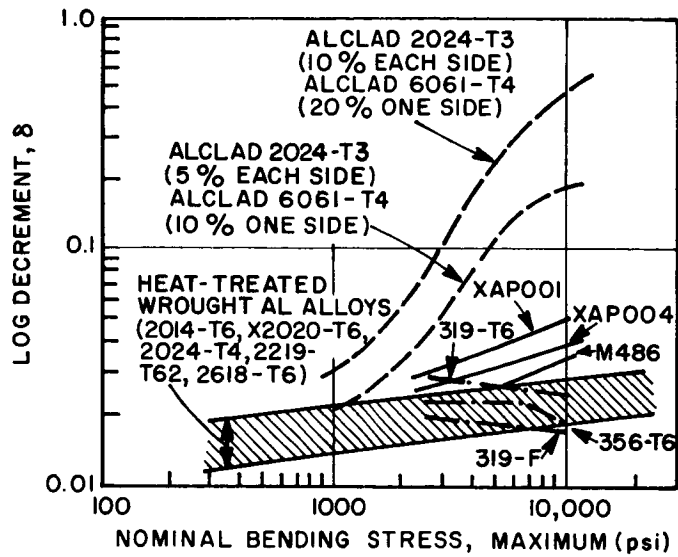

Figure 11. Damping Characteristics of Wrought, Cast, and APM Aluminum Alloys. Note how Alcladding Increases δ . (After Kaufman¹⁰)

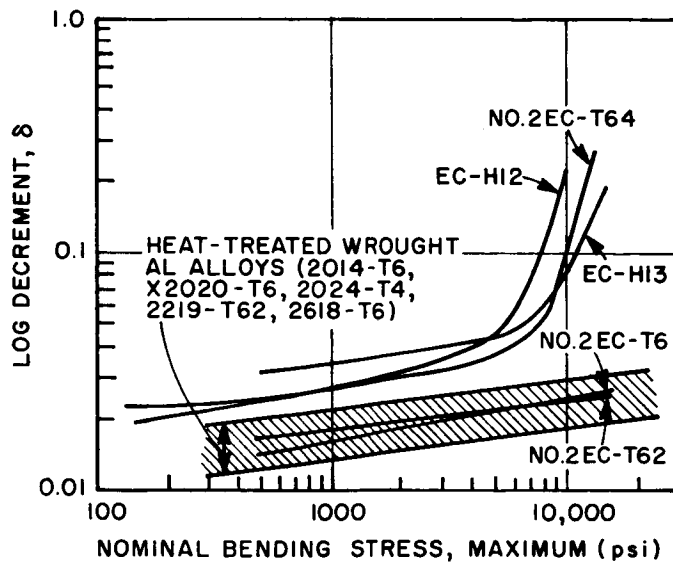

Figure 12. Low Strength Electrical Conductor Alloys have Significantly Greater Damping Capacity than Wrought Alloys (After Kaufman¹⁰)

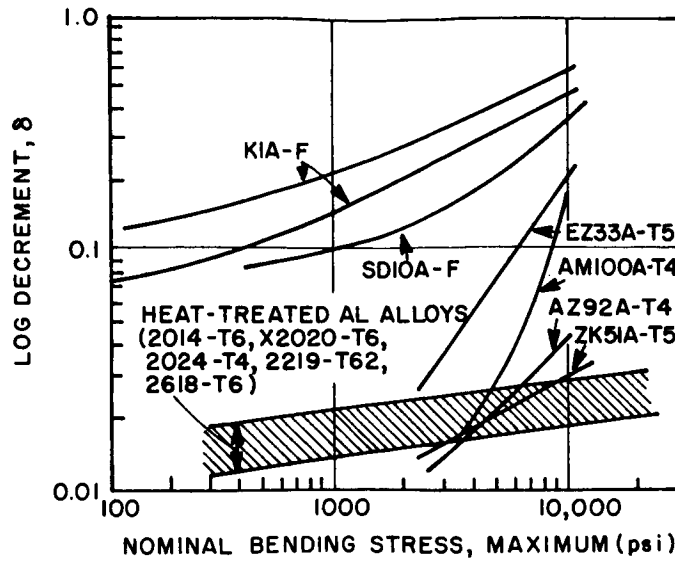

Figure 13. Some Cast Magnesium Alloys have 10 to 20 Times more Damping Capacity than Wrought Aluminum Alloys (After Kaufman¹⁰)

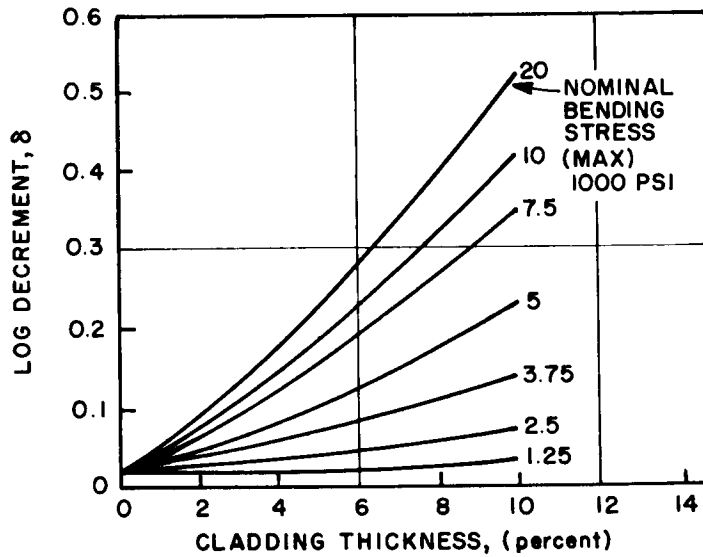

Figure 14. Cladding Increases the Damping Capacity of Aluminum Alloys. Cladding can be on One or Both Sides (After Kaufman¹⁰)

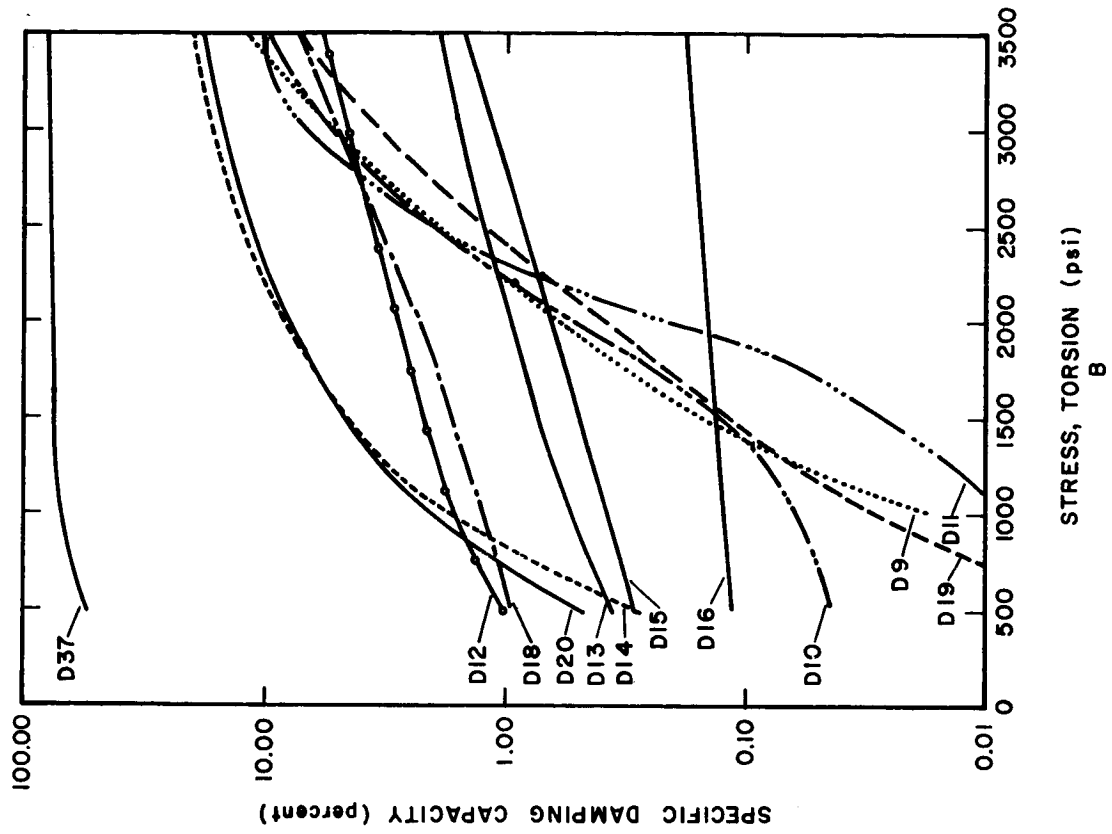
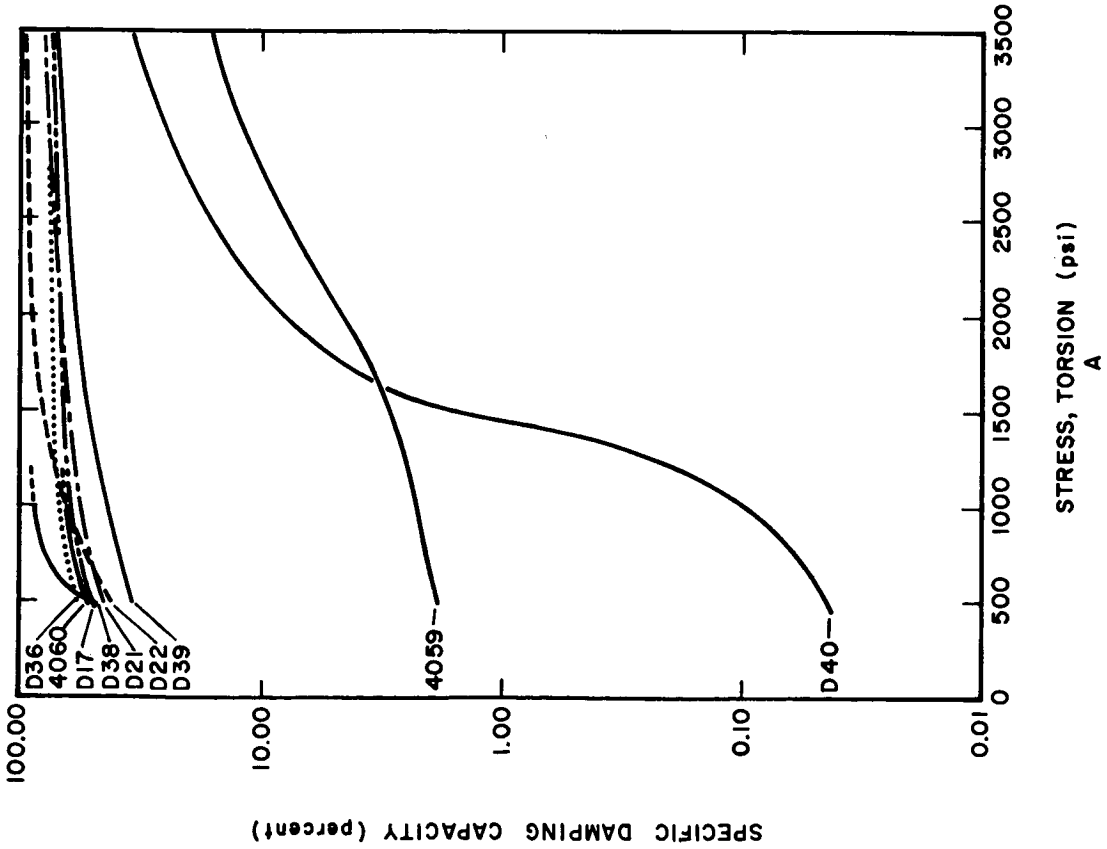

Figure 15. Vibration Damping Capacity of Magnesium Alloys: A, As Cast; B, As Cast and Heat Treated (After Walsh, et al., ¹¹)

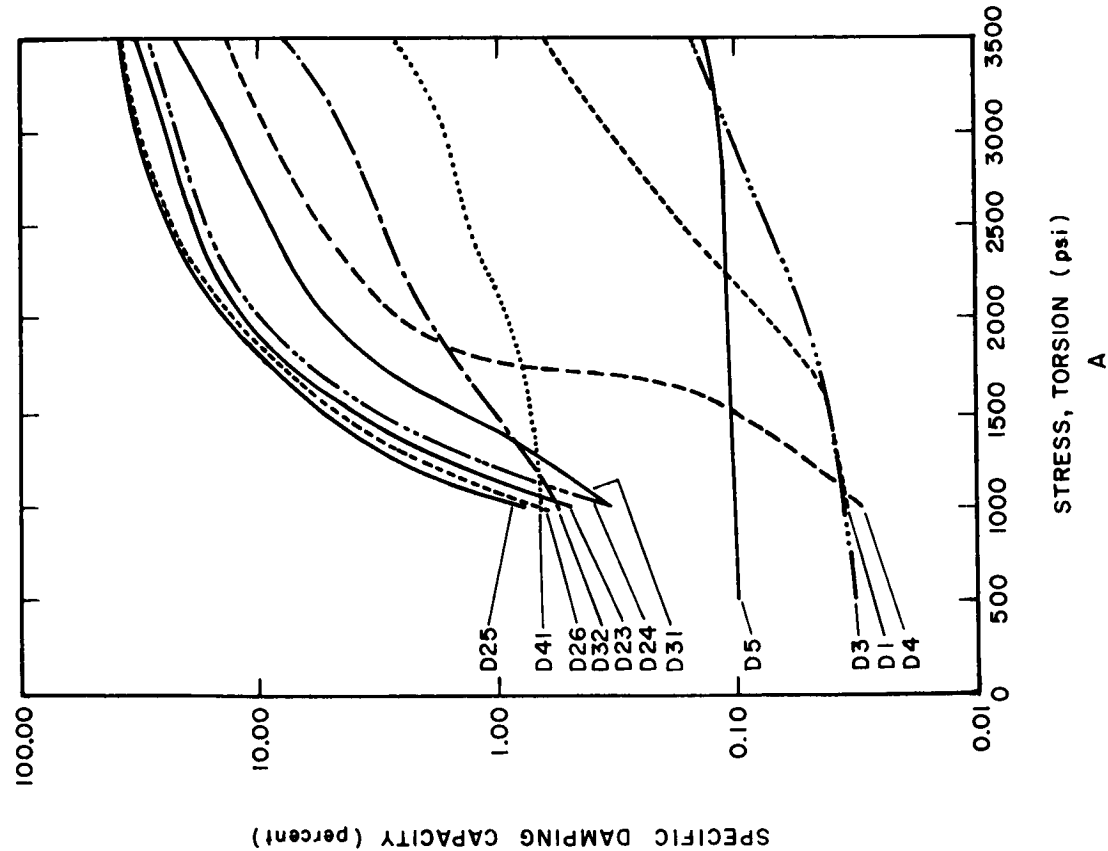
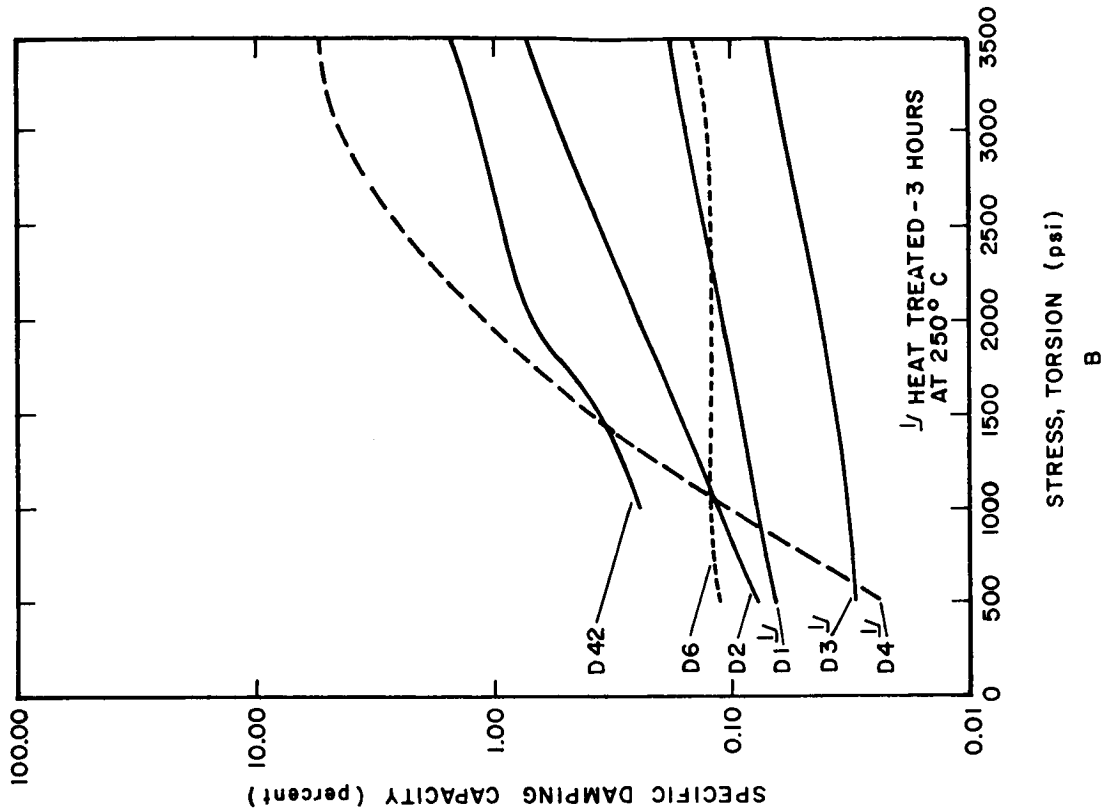

Figure 16. Vibration Damping Capacity of Magnesium Alloys: A, As Wrought; B, As Wrought and Heat Treated (After Walsh, et al.,¹¹)

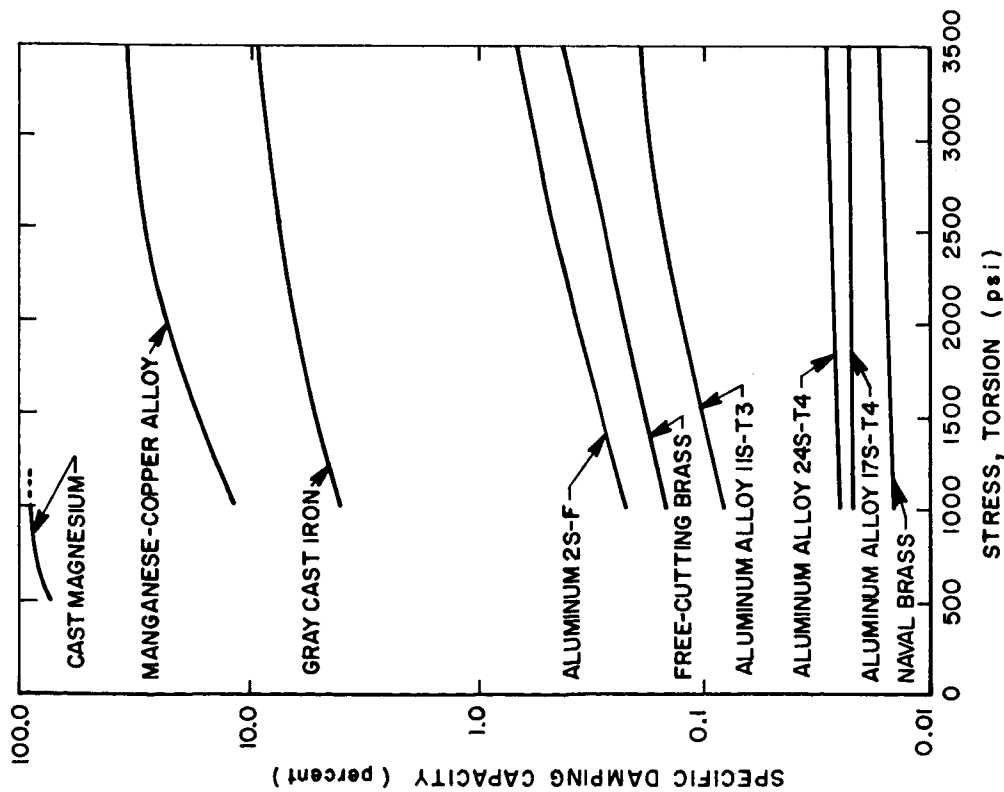

Figure 17. Vibration Damping Capacity of Cast Magnesium and Selected Commercial Alloys (After Walsh, et al., ¹¹)

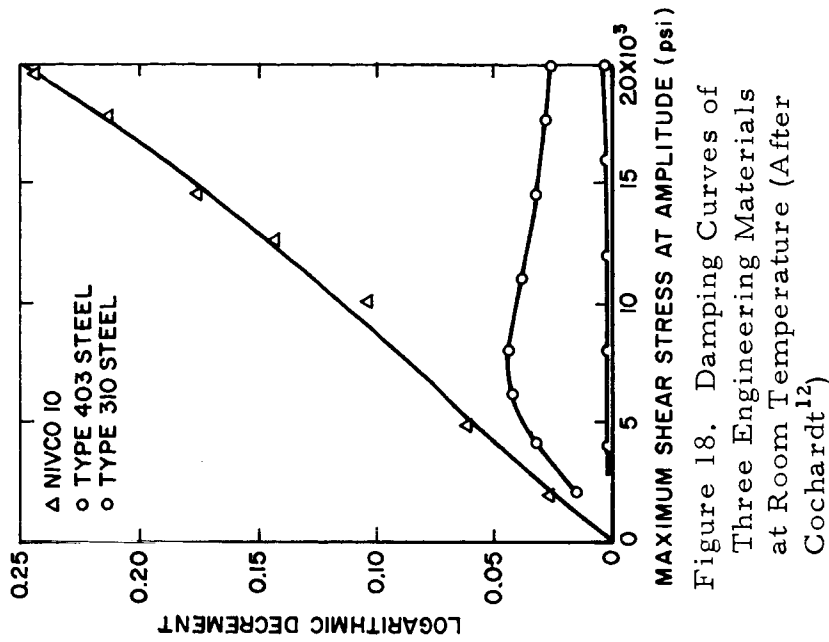

Figure 18. Damping Curves of Three Engineering Materials at Room Temperature (After Cochardt¹²)

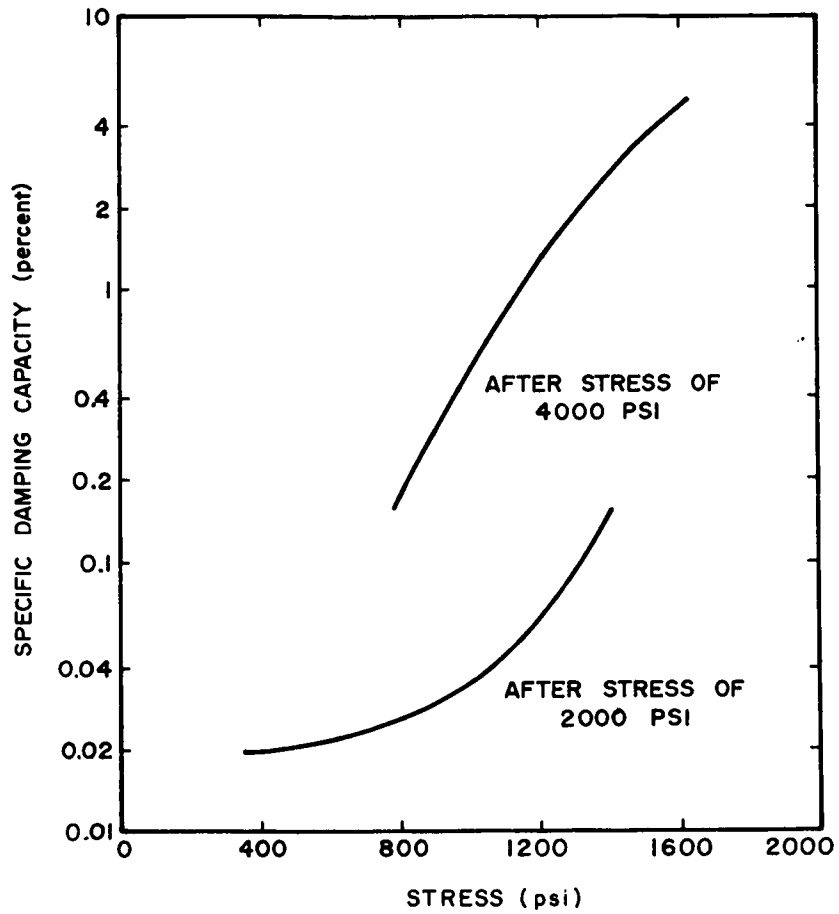

Figure 19. Vibration Damping Capacity Versus Stress, for the Same Specimen of a Magnesium Alloy, Varied by Prior Stressing (After Walsh, et al.,¹¹)

LITERATURE CITED

1. AFML,
BIBLIOGRAPHY AND ABSTRACTS OF PUBLICATIONS FOR PERIOD 1956-1964 DEALING WITH DAMPING PROPERTIES OF MATERIALS by J. L. Wood and L. T. Lee, Technical Report 65-22, August 1965.
2. United States Bureau of Mines,
DAMPING CAPACITY-ITS MEASUREMENT AND SIGNIFICANCE by J. W. Jenson, Report, Report of Investigations 5441, 1959.
3. Edward Arnold, Limited, London, England,
THE DAMPING CAPACITY OF METALS by K. M. Entwistle, The Physical Examination of Metals, 1960, pp. 487-558.
4. C. Wert,
THE METALLURGICAL USE OF ANELASTICITY, Proceedings, Modern Research Techniques in Physical Metallurgy, Cleveland, Ohio, 1953, pp. 225-250.
5. A. Salvi, D. Dautreppe, and E. Friess,
AUTOMATIC TORSION PENDULUM FOR CONTINUOUS RECORDING OF INTERNAL FRICTION AT CONSTANT AMPLITUDE AND VERY LOW FREQUENCIES, Review of Scientific Instruments, Vol. 36, No. 2, February 1965.
6. T. Hinton,
MEASUREMENT OF INTERNAL FRICTION IN THE KILOCYCLE FREQUENCY RANGE, Review of Scientific Instruments, Vol. 36, No. 8, August 1965, pp. 1114-1119.
7. A. S. Nowick,
INTERNAL FRICTION IN METALS, Progress in Metal Physics, Vol. 4, London, England, Pergamon Press, 1953, pp. 1-70, Edited by Bruce Chalmers.
8. W. P. Mason,
USE OF ULTRASONIC AND HYPERSONIC VELOCITY AND ATTENUATION MEASUREMENTS IN DETERMINING IMPERFECTION MOTIONS IN SOLIDS, Applied Mechanics Review, Vol. 18, No. 4, April 1965, pp. 257-263.

LITERATURE CITED (Concluded)

9. D. Birchon,
HIGH-DAMPING ALLOYS, Engineering Materials and Design,
Part 1, Vol. 7, 1964, pp. 606-608; Part 2, Vol. 7, 1964,
pp. 692-696.
10. J. G. Kaufman,
DAMPING OF LIGHT METALS, Materials in Design Engineering,
Vol. 56, 1962, pp. 104-105.
11. United States Bureau of Mines,
VIBRATION DAMPING CAPACITY OF VARIOUS MAGNESIUM
ALLOYS by D. F. Walsh, J. W. Jenson, and J. A. Rowland,
Report of Investigations 6116, 1962.
12. A. Cochardt,
MAGNETOMECHANICAL DAMPING, Proceeding, Magnetic
Properties of Metals and Alloys, American Society for Metals,
Novelty, Ohio, 1959, pp. 251-279.
13. H. Kolsky,
THE MECHANICAL TESTING OF HIGH POLYMERS, Progress
in Nondestructive Testing, New York, New York, MacMillan
Company, Vol. 2, 1960, pp. 28-59.
14. E. Plenard,
CAST IRON DAMPING CAPACITY, STRUCTURE, AND
PROPERTY RELATIONS, New Technology, May 1962,
pp. 144-151.

Appendix A. SELECTED BIBLIOGRAPHY

1. Aamink, D. K., Webbre, F. J., and Boegehold, A. L.,
G. M. RESEARCH LABS DEVELOP. NEW (NICKEL) TUR-
BINE BUCKET ALLOYS, S. A. E. Journal, Vol. 63, No. 8,
1955, pp. 36-38.

Damping tests are carried on in addition to the various mechanical tests with this new alloy.

2. Adamson, B. A.,
A METHOD FOR MEASURING DAMPING AND FREQUENCIES
OF HIGH MODES OF VIBRATION OF BEAMS, Publ. Int.
Assn. Bridge Struct. Engng., 1955, 16 pp.

Two experimental methods for determining natural frequencies of high modes of vibration of beams are proposed. The use of both methods simultaneously permits determination of damping as well.

The first method makes use of a load distribution similar to the n th mode of vibration. The second method requires that two series-coupled strain gages be cemented to the beam at places which result in the maximum output of certain modes.

It is found that Mindlin's "constant Q theory" best expresses damping in these beams. It is also concluded that Timoshenko's theory involving rotational inertia and shearing forces comes closest to agreeing with the measured frequencies.

3. Alers, G. A.,
ULTRASONIC ATTENUATION IN ZINC SINGLE CRYSTALS
WHILE UNDERGOING PLASTIC DEFORMATION, Physical
Review, Vol. 97, 1955, pp. 863-869.

The attenuation of 7 mc/sec ultrasonic pulses in zinc single crystals before, during, and following plastic deformation was measured by the ultrasonic-pulse technique. Simultaneous measurements of the time-dependent plastic strain at constant stress were made in order to study the correlation between this strain and the attenuation.

4. Anderson, O. L. and Bömmel, H. E.,
ULTRASONIC ABSORPTION IN FUSED SILICA AT LOW
TEMPERATURES AND HIGH FREQUENCIES, American
Ceramic Society, Journal, Vol. 38, No. 4, 1955, pp. 125-
131.

Absorption of 60 kc/sec to 20 mc/sec sound waves at temperatures of 30° to 50° K appears to result from property of glassy state since absorption does not occur in crystalline silica.

5. Ang, C. Y., Sivertsen, J., and Wert, C.,
ANELASTIC PHENOMENA IN ALLOYS OF GOLD AND NICKEL, Acta Metallurgica, Vol. 3, 1955, pp. 558-565.

Two relaxation peaks are found in polycrystalline alloys of gold and nickel between room temperature and 600°. One of these peaks was identified as the order peak; the origin of the other is uncertain. Both peaks exist in alloys quenched from the solid-solution region of the constitution diagram. Upon annealing of these quenched solid solutions, both peaks disappear.

6. Angliioletti, A.,
APPARATUS FOR DYNAMIC MEASUREMENTS OF HYSTERESIS AND SHEAR MODULUS OF RUBBER VULCANISATES, Kautschuk und Gummi, Vol. 8, WT, 1955, pp. 219-226.

This apparatus for measurement of dynamic shear modulus and hysteresis loss is suitable for routine laboratory measurements; it employs the forced-resonance torsional oscillations of a system in which the test piece represents the viscoelastic element. The frequencies available for the experiments are between 20 and 100 cps, the temperatures between -20° and 110° C.

7. Anonymous,
SANDWICH MOUNT DAMPS SHOCK, Aviation Week, Vol. 63,
24 October 1955, p. 86.

Illustration and brief description of aluminum and rubber sandwich support bracket and shock mountings developed by the Stillman Rubber Company to support after-body engine

sections of the Lockheed 1049A. The Flexmount was designed to withstand applied loads in shear and additional loads caused by engine vibrations.

8. Anonymous,
WHICH TYPE OF PULSATION DAMPENER FITS YOUR
COMPRESSOR PROBLEM? Petroleum Processing, Vol. 10,
November 1955, pp. 1724-1725.

This article was based on the paper, "Control of Pulsations in Piping Systems", by C. Newman and N. H. Moerke, presented at the American Society of Mechanical Engineers' Petroleum Mechanical Engineering Conference, September 1955. The article describes high-pass and low-pass dampeners.

9. Antonovich, A. V.,
AUTOMATIC RECORDING SYSTEM FOR MEASURING
DURATION OF OSCILLATION PROCESSES, Zavodskaya
Laboratoriya, Vol. 21, No. 6, 1955, pp. 728-731 (In Russian).

The apparatus described permits recording of duration of oscillation processes in some special cases of laboratory investigations; in particular, when testing metallic samples or components for fatigue continued to the destruction point. The transmitter of the apparatus consists of a metallic plate placed near the oscillating components, constituting with it a capacitor with an aid dielectric. The oscillation of the sample gives rise to change in capacitance, which, in its turn, causes current pulsation in the transmitter circuit. The pulsations are amplified by a three-stage amplifier and recorded on a special self-recording device; from this record, it is possible to establish the instant the oscillations of the component stop, or the instant of component destruction.

10. Arnold, F. R.,
STEADY-STATE BEHAVIOR OF SYSTEMS PROVIDED WITH
NONLINEAR DYNAMIC VIBRATION ABSORBERS, Journal
of Applied Mechanics, Vol. 22, December 1955, pp. 487-492.

The nonlinear dynamic vibration absorber is included in the systems studied.

11. Asanuma, M. and Ogawa, S.,
THE MAGNETIC AGING OF PURE IRON(II), Physical Society of Japan, Journal, Vol. 10, 1955, pp. 1025-1026.

A wire of commercially pure iron was purified by annealing in a wet H₂ atmosphere and then dissolving 0.0065 percent by weight nitrogen in the specimen. The precipitation during aging was investigated by measuring the internal friction at 140°. The decrease of initial susceptibility versus aging time at 140° was found. It is concluded that Fe₁₆N₂ which precipitates first is dominantly responsible for the decrease of magnetic initial susceptibility. Fe₄N precipitates later and affects the susceptibility to a lesser extent.

12. Bainton, G. W.,
USE OF THE REPEATED HYSTERESIS LOOP FOR EVALUATING REINFORCED PLASTICS, Plastics Technology, June 1955, pp. 290-294.

Standard strength tests have been used to determine the relative worth of resins and filler structures under various conditions of temperature and humidity, and much has been learned in the past about behavior under static load through the use of creep tests. It is the purpose of this paper to show that such data can be supplemented by the study of the hysteresis loops and flexural modulus during repeated unidirectional cycling of a specimen in flexure. The paper is concerned in particular with the variation in safe working loads as a function of differences in reinforcing structure, and with the rate and mechanism of failure encountered. Three types of glass reinforcement were used in these tests: rove cloth, fabric, and unidirectional roving. The magnitude of the resin-glass interface plane in shear varies with different sample constructions and controls the behavior of the samples under repeated stress. It was found that hysteresis energy loss provides a means of measuring the effect of stress at the resin-glass interface. With repeated stress cycles, measurement of hysteresis loss provides a means of following the changes occurring at this interface. The flexural modulus indicates the degree to which the glass fibers take stress in tension and compression. With repeated stress cycles, changes in flexural modulus indicate changes (broken fibers, loosened fiber bundles) in the ability of the glass to take load.

13. Berry, B. S.,
APPARATUS FOR THE MEASUREMENT OF THE INTERNAL
FRICTION OF METALS IN TRANSVERSE VIBRATION,
Review of Scientific Instruments, Vol. 26, 1955, pp. 884-887.

For measuring the internal friction of vertically suspended specimens, vibrating transversely, a device is described which has utilized a piezoelectric pickup of special design to serve in turn as an exciter and detector. The apparatus was suitable for measurements by the free-decay method in the frequency range of 5 cps to 2 kc/sec and at maximum strain-amplitudes of 10^{-4} to 5×10^{-7} .

14. Berry, B. S.,
PRECISE INVESTIGATION OF THE THEORY OF DAMPING
BY TRANSVERSE THERMAL CURRENTS, Journal of Applied Physics, Vol. 26, No. 10, October 1955, pp. 1221-1225.

The frequency-dependence of internal friction of four alpha-brass (62.5 percent copper) reeds was measured at room temperature under conditions where contributions to the internal friction other than that arising from transverse thermal currents were small and assessable. Measurements were made by the free-decay method at maximum strain amplitudes of 5×10^{-6} . By using specimens of two different thicknesses, frequencies differing from the frequency of peak damping by nearly a factor of 20 were obtained by measurements in the range 7 to 370 cps.

15. Birnbaum, H. K.,
DOUBLE-VALUED INTERNAL FRICTION BEHAVIOR, Acta Metallurgica, Vol. 3, No. 3, May 1955, pp. 297-299.

Single crystals of sodium chloride, silver and aluminum relate type I (large hysteresis) and type II (small hysteresis) behavior.

16. Bishop, R. E. D.,
THE TREATMENT OF DAMPING FORCES IN VIBRATION
THEORY, Royal Aeronautical Society, Journal, Vol. 59, No. 539, 1955, pp. 738-742.

The purpose of mathematical theories of damping in vibration theory is discussed. It is concluded that the theory of hysteretic damping is a useful one since it provides an

alternative to the friction of viscous damping while retaining mathematical linearity in the equations of motion. The word hysteretic is proposed for use in this sense instead of the previously used adjective, namely structural. Complex damping is related to hysteretic damping in a way that is explained.

The theory is given for forced oscillations of a system with one degree of freedom. It is shown that free vibration cannot be treated satisfactorily unless the definition of hysteretic damping is widened in some way to cover non-harmonic motion.

17. Bleakney, H. H. ,
AN EVALUATION OF THE RECOVERY THEORY OF CREEP,
Canadian Journal of Technology, Vol. 33, January 1955,
pp. 56-65.

In this paper, evidence is presented to show that the phenomenon of creep-rupture embrittlement is not necessarily inconsistent with the recovery theory; that the equi-cohesive temperature concept may be invalid; and that Kê's conclusions are not substantiated by the evidence. It is suggested that the opposing influences of strain-hardening and thermal softening, modified by factors introduced by metallurgical instabilities, are the fundamental verities of creep.

18. Bleakney, H. H. ,
INTERNAL FRICTION IN TITANIUM AND TITANIUM-
OXYGEN ALLOYS, Acta Metallurgica, Vol. 3, No. 1,
January 1955, pp. 103-104.

This article shows that stress relaxation across grain boundaries cannot explain the rapid drop in modulus of elasticity at elevated temperatures.

19. Bömmel, H. E. ,
ULTRASONIC ATTENUATION IN SUPERCONDUCTING AND
NORMAL-CONDUCTING TIN AT LOW TEMPERATURES,
Physical Review, Vol. 100, No. 2, 15 October 1955, pp. 758-
759.

Tin single crystals of 99.98 percent show at 10.3 mc/sec an attenuation which is, at its maximum value (at the transition temperature), 100 times larger than that of a 99.98

percent crystal. In the purer sample, the attenuation in the normal state is substantially decreased by magnetic fields of a few hundred oersted. This is ascribed to the magneto-resistive effect which is appreciable at the high conductivities (approximately 10^{10} ohm⁻¹ cm⁻¹) involved.

20. Bömmel, H. E., Mason, W. P., and Warner, A. W., Jr., EXPERIMENTAL EVIDENCE FOR DISLOCATIONS IN CRYSTALLINE QUARTZ, Physical Review, Vol. 99, No. 6, 15 September 1955, pp. 1894-1895.

Measurements of the internal friction of single crystals from 1.5° to 300° K in the 5 to 80 mc/sec region are described. These show that two relaxation frequency T curves are obtained, the lower activation energy curve being attributed to dislocations.

21. Bordoni, P. G., INVESTIGATIONS OF THE SOLID STATE AT HIGH TEMPERATURES CARRIED OUT BY MEANS OF ULTRASONICS, Journal de Physique et le Radium, Vol. 16, 1955, pp. 285-289; Ricerca Scientifica, Vol. 25, 1955, pp. 847-859.

A systematic ultrasonic study is being made on the elastic and anelastic properties of antimony, lead, zinc, bismuth, cadmium, magnesium, aluminum, and copper. Thus far, the results show that when the temperature increases, the tension modulus and the torsion modulus tend toward a limiting value different from zero, following a law of a general type that can be deduced from statistical mechanics.

22. Brekhovskikh, L. M. and Ivanov, I. D., ON ONE SPECIAL FORM OF DAMPING IN WAVE PROPAGATION IN LAMINAR NONHOMOGENEOUS MEDIA, Akusticheski Zhurnal, Vol. 1, No. 1, 1955, pp. 23-30 (In Russian).

An examination was made of wave propagation in a layer which is bounded on one side by a nonhomogeneous medium in which the wave propagation velocity decreases with the distance from the boundary of the layer. The second boundary layer is assumed to be absolutely reflecting. It is shown that wave propagation in this layer is accompanied by an additional weakening, which is caused by "sucking away" of

the wave energy by a nonhomogeneous medium. The value of the additional damping was determined, in relation to the distance from the radiator, the wave length, the disposition depth of the receiver, and of the radiator, and the value characterizing the variation in the velocity of sound according to the depth in a nonhomogeneous medium.

23. Brook, G. B. and Sully, A. H.,
SOME OBSERVATIONS ON THE INTERNAL FRICTION OF
POLYCRYSTALLINE ALUMINUM DURING THE EARLY
STAGES OF CREEP, Acta Metallurgica, Vol. 3, No. 5,
September 1955, pp. 460-469.

Measurements at strain amplitudes less than 10^{-5} made at constant load of super- and commercial-purity aluminum wires at room temperature, 250° and 350° C.

24. Brown, H.,
LOW-EXPANSION CAST IRON, Machine Design, Vol. 27,
June 1955, pp. 175-177.

Min-o-var, a 36-percent nickel alloy, has vibration damping capacity due to graphite flake dispersion similar to gray iron.

25. Brown University, Providence, Rhode Island,
INTERNAL FRICTION AND MODULUS CHANGES DUE TO
DISLOCATION DAMPING IN UNDEFORMED CRYSTALS--
PART II--COMPARISON OF THEORY WITH EXPERIMENT
by A. Granato and K. Lucke, January 1955, AD-626 37,
79 pp.

A theory, based on a model used by Koehler, is developed to a point where quantitative checks are possible. It is found that the same model leads to both the kind of loss found in the kilocycle region and that found in the megacycle region. The predicted results of the theory are compared insofar as is possible with available data in respect to the dependence of the loss on the principal variables, and on many of the parameters.

26. Busemann, K. ,
SHIFTED LOGARITHMIC SPIRALS FOR THE PLOTTING OF DAMPED VIBRATIONS AND THEIR DERIVATIONS FOR THE CALCULATIONS OF BEAMS ON ELASTIC FOUNDATION AND FOR THE CALCULATION OF CIRCULAR CYLINDRICAL SHELLS WITH UNIFORMLY DISTRIBUTED SYMMETRICAL LOADS, Stahlbau, Vol. 24, April 1955, pp. 73-77 (In German).

A graphical method using logarithmic spirals $r = r_0 e^{-u}$ was developed for the calculation of the internal forces of a beam on an elastic foundation. Various cases of the loading of the beam are discussed. The author considers the wall of circular cylindrical shell to be composed of straight beams resting on circular beams. By regarding the circular beams as an elastic foundation for the straight ones, the author applies his graphical method to calculate the internal forces in a uniform symmetrically loaded cylindrical shell.

27. Cabarat, R. ,
QUENCHING OF A LIGHT ALLOY WITH REFERENCE TO ITS ELASTIC PROPERTIES, International Congress of Aluminum (Paris), 1954, Vol. 1, 1955, pp. 271-273.

Alloys of the composition 7 to 8.5 percent zinc, 1.75 to 3 percent magnesium, 1 to 2 percent copper, 0.1 to 0.6 percent manganese, 0.2 to 0.4 percent chromium and the remainder aluminum were studied. A new dynamic (electrostatic) method was used to measure the modulus of elasticity and the internal friction. The changes in internal friction, modulus of elasticity, hardness, and conditions with time at room temperature after quenching from 450°, are reported. The internal friction curve shows a sharp maximum at about two hours.

28. Chatterjee, G. P. ,
VIBRATION DAMPING CAPACITY AND ANELASTICITY OF METALS AND ALLOYS FROM ENERGY CONSIDERATION, First Congress on Theories and Applied Mechanics, Proceedings, November 1955, pp. 95-106.

Not abstracted.

29. Cochardt, A. W. ,
EFFECT OF STATIC STRESS ON THE DAMPING OF SOME
ENGINEERING ALLOYS, American Society for Metals
Transactions Quarterly, Vol. 47, 1955, pp. 440-450.

Wires of alloy type AISI 403 and Refractaloy 26 were twisted, and decay of free torsion vibration was measured; damping of the former was found to be considerably affected by superimposed static stress; damping of Refractaloy 26 always increases with static stress.

30. Corbetta, G. ,
CENTRIFUGAL PENDULUM DAMPER OF TORSIONAL
VIBRATIONS, Ingeguera, Vol. 29, No. 4, April 1955, pp. 351-
361.

Study of a system of two masses connected to each other and to a fixed point by means of springs; characteristics of a centrifugal pendulum; its application to shafts of ac internal combustion motors; and results obtained for application of dampers.

31. Cornell University, Office of Naval Research, U. S. Office of
Technical Services,
DYNAMIC PROPERTIES OF SOLIDS by T. R. Cuykendall and
H. S. Sack, November 1955, Report No. PB 121701, 115 pp.
(Final Report).

This report presents determinations of the elastic modulus and the internal friction of solids under alternating stresses.

32. Crawford, A. R. ,
VIBRATIONS ELIMINATED WITHOUT MAJOR DISASSEMBLY,
Machinery, Vol. 62, October 1955, pp. 199-201.

Out-of-balance of rotating parts can be detected by a vibration analyzer, designed by the International Research and Development Corporation, which makes unnecessary a major disassembly of a machine or mechanism.

33. Damask, A. C. and Nowick, A. S.,
INTERNAL FRICTION PEAK ASSOCIATED WITH PRECIPITATION IN AN Al-Ag ALLOY, Journal of Applied Physics, Vol. 26, September 1955, pp. 1165-1172.

Specimen quenched from solid-solution region and aged at 155° C shows peak at 140° C for vibration frequency of 0.25 cps.

34. Deutsche Versuchsanstalt Luftfahrt,
VIBRATION BEHAVIOR OF A BLADE RING IN VACUUM by H. Sohngen, August 1955, E. V. Rept. 1, 24 pp. (In German).

The vibrations of blade rings on axial compressors and turbines are investigated. It is assumed that the modes and frequencies of free vibrations of a single blade are known and further that the displacements of neighboring blades are coupled through the ring. With these assumptions, an analysis is made of the natural, damped, and forced modes and frequencies of vibrations of the blade ring in a vacuum. Examined are: 1) blades having the same frequency and 2) blades having two alternate natural frequencies.

35. Doak, K. W.,
RUBBER-CARBON BLACK TREATMENT, United States Rubber Company, United States Patent 2720499, applied 12 November 1952, accepted 11 October 1955.

The patent provides a chemical promoter, hexachlorocyclopentadiene, for the processing of rubber-carbon black mixtures at high temperatures, as disclosed in U. S. P. 21118601 to produce stocks with low torsional hysteresis suitable for tire treads. Examples show the effectiveness of this promoter in increasing specific electrical resistivity and decreasing torsional hysteresis.

36. Doak, K. W.,
RUBBER TREATMENT, United States Rubber Company, United States Patent 2715618, applied 16 December 1953, accepted 16 August 1955.

The process described is that claimed in U. S. P. 2118601 for producing low hysteresis rubber, and is concerned with a new chemical promoter for the process. Rubber, 100 parts, is mixed with a relatively large proportion of carbon black

and 0.75 to 3 parts of lithium nitrate calculated as the anhydrous salt. The mixture is heated to a temperature of at least 275° F. The process increases electrical resistivity by a factor of 375 and lowers torsional hysteresis by 35 percent.

37. Doak, K. W.,
RUBBER TREATMENT, United States Rubber Company,
United States Patent 2715650, applied 12 January 1954,
accepted 16 August 1955.

The process described in U. S. P. 2118601 for producing a low hysteresis rubber is accelerated by incorporating 0.5 to 3 parts per 100 of rubber, natural or synthetic, of an alkali or alkali earth metal nitrite, preferably sodium or potassium nitrite, and heating the mixture to at least 275° F. This increases electrical resistivity by a factor of 100,000 and lowers hysteresis at 280° F by 35 percent. A relatively large amount of carbon black is added to the mix.

38. Eisele, F. and Lysen, H. W.,
THE EMPLOYMENT OF HIGH POLYMER MATERIALS FOR
DYNAMIC STIFFNESS IN MACHINE TOOLS, Forsch. -und-
Konstr. Wzm. (FoKoMa), Munchen, Vol. 2, 1955, pp. 89-93
(In German).

The application of high polymers to the surfaces of machine parts to increase the total damping of the system is described in this article. The principal property specification for high polymers is high-loss coefficient over a broad temperature range. The authors discuss how and where to add the damping material to get the greatest increase in total damping. Several examples are given to illustrate the principles.

39. Erith, L. and Slezinger, I.,
VIBRATION DAMPER WITH SHOCK ACTION, Vol. 7,
October 1955, pp. 371-376.

Not abstracted.

40. Fast, J. D. and Verrijp, M. B.,
SOLUBILITY OF NITROGEN IN α - IRON, Iron and Steel
Institute, Journal (London), No. 180, 1955, pp. 337-343.

Iron was obtained in very pure state by high-frequency melting and casting in vacuum. The internal friction of fine-grained textureless alpha-iron wires caused by nitrogen is proportional to the nitrogen content up to the solubility at the eutectoid temperature. The solubility increased from 1.4×10^{-5} at 20° to 4.5×10^{-3} percent by weight nitrogen at 900° . Exponential equations are given for the solubility in equilibrium with Fe_4N and N_2 . From two of these equations the dissociation pressure of Fe_4 is calculated.

41. Ferro, A. and Montalenti, G.,
ON THE ACTIVATION ENERGY OF INTERSTITIAL CARBON
AND NITROGEN IN IRON ALLOYS, (Sull'energia di attivazione del carbonio ed azoto interstiziale nelle leghe di ferro.), Ricerca Scientifica, Vol. 25, No. 11, November 1955, pp. 3069-3081.

After measuring the diffusion of carbon contained in an iron-silicon alloy by magnetic relaxation methods, a theoretical explanation is given of the higher heat of activation shown by carbon and nitrogen atoms, diffusing in iron alloys with respect to pure iron.

42. Friedel, J., Boulanger, C., and Crussard, C.,
ELASTIC MODULUS AND INTERNAL FRICTION OF POLY-
GONIZED ALUMINUM, Acta Metallurgica, Vol. 3, No. 4,
July 1955, pp. 380-391.

This article presents an observation in polygonized coarse-grained aluminum at elevated temperature of a strong drop of Young's modulus while the internal friction reaches high values.

43. Gebhardt, E. and Preisendanz, H.,
SOLUBILITY OF OXYGEN IN TANTALUM AND RELATED
CHANGES IN TANTALUM PROPERTIES, Zeitschrift für
Metallkunde, Vol. 46, No. 8, August 1955, pp. 560-568.

Development of a method at very high temperatures and very low pressures to show the influence of oxygen on

damping, modulus of elasticity, magnetic susceptibility, hardness, tensile strength, elongation, necking, and chemical behavior of tantalum.

44. General Electric Company,
RESONANT FATIGUE STRENGTH COMPARISONS CONSIDERING BOTH MATERIAL DAMPING AND STRESS DISTRIBUTION IN PARTS by B. J. Lazan and E. Podnieks, October 1955, Report No. R55GL359.

Not abstracted.

45. General Electric Company,
THE DAMPING PROPERTIES OF MATERIALS AND THEIR RELATIONSHIP TO RESONANT FATIGUE STRENGTH OF PARTS by B. J. Lazan, 11 January 1955, Report No. R55GL129.

In this report, the damping properties of common structural materials are discussed with a view towards applying the information to the design of machine parts. Basic terms, which are used to express damping test results, are defined and their uses compared. Various methods and devices for measuring damping are evaluated. The probable causes of stress amplitude and history, temperature, frequency, rest periods, and mean stress are discussed.

46. Hanstock, R. F.,
FATIGUE PHENOMENA IN HIGH STRENGTH ALUMINUM ALLOYS, Institute of Metals, Journal, Vol. 83, 1954-1955, pp. 11-15.

The increase in damping capacity that precedes fatigue failure of the aluminum alloys L65 and DTD 683 is associated with precipitate instability. The fatigue strength depends on the magnitude of the stress required to initiate precipitation and on the strength of the over-precipitated regions.

An alloy that derives its high static strength from a controlled state of precipitation that is unstable under cyclic stressing will have a high ratio of static ultimate strength to fatigue strength.

47. Hasiguti, R. R., Hirai, T., Kamoshita, G., and Igata, N.,
INTERNAL FRICTION OF COPPER DUE TO POINT IMPER-
FECTIONS IN THE CRYSTAL LATTICE, Metal Physics,
Vol. 1, No. 3, 1955, pp. 111-112 (In Japanese).

Not abstracted.

48. Hirone, T. and Kamigaki, K.,
THE ATTENUATION OF ULTRASONIC WAVES IN METALS
I. -ALUMINUM, Science Report of the Tohoku University
(Research Institute), Series A, Vol. 7, No. 5, 1955, pp. 455-
464.

Attenuation coefficient, C , of longitudinal ultrasonic waves of frequencies 2 to 25 mc/sec were studied in aluminum by the impulse-reflection method. General features of the change of C with frequency and grain size are reported.

49. Hirone, T., Kunitomi, N., and Abe, M.,
THE MECHANISM OF INTERNAL FRICTION DUE TO THE
MOTION OF THE DISLOCATION, Physical Society of Japan,
Journal, Vol. 10, No. 11, November 1955, pp. 960-966.

For copper, internal friction increases with the initial cold work and decreases after showing a maximum. Since the behavior does not depend on the frequency used in the experiment at room temperatures, internal friction due to dislocations is concluded to originate from the static hysteresis proposed by Nowick.

50. Hueter, T. F. and Bolt, R. H.,
SONICS, N. Y., John Wiley and Sons., Incorporated, 1955,
456 pp.

"Sonics" encompasses the analysis, testing, and processing of materials and products by the use of mechanical vibratory energy. All applications are based on the same physical principles. The unity of sonics is, therefore, the keynote of this book. The common principles are presented in general form and then applied in many special ways to the design of sonic techniques for a particular medium or frequency range. In the chapter on principles of sonic testing and analysis, internal damping in metals is discussed.

51. Illinois University, Urbana, Illinois,
INTERNAL FRICTION OF COPPER AND COPPER ALLOYS
by D. N. Beshers, November 1955, Technical Report No. 3,
NG ori 071, 54; University Microfilms, Ann Arbor, Michigan,
P. N. 16383.

The logarithmic decrement and the Young's modulus of single crystals of 99.999 percent pure copper and copper crystals containing known concentrations of gold were measured as a function of the strain amplitude, of time, and as a function of temperature.

52. Iwata, T.,
A STATISTICAL THEORY OF ANISOTROPIC DISTRIBUTION
OF ATOM PAIRS IN BINARY ALLOYS, Japanese Institute
of Metals, Journal, Vol. 19, 1955, pp. 95-99.

A statistical theory of anisotropic distribution of atom pairs responsible for the additional magnetic anisotropy in field-cooled or cold-worked ferromagnetic solid solutions as well as for the internal friction of the alpha-brass type is developed in connection with the ordinary order-disorder phenomenon.

53. Johnson, E. A.,
PROPER MOUNT DESIGN, SELECTION AID VIBRATION
CONTROL, Iron Age, Vol. 175, No. 8, 1955, pp. 86-87.

Not abstracted.

54. Kamel, R.,
RELAXATION OF THE PRECIPITATED COPPER ATOMS IN
THE BINARY ALLOY AuCu, Japanese Institute of Metals,
Journal, Vol. 84, 1955, pp. 55-56.

The relaxation of copper atoms precipitated from the binary 50:50 atomic percent gold-copper manifests itself by a continuous rise in the internal friction/temperature curve. The dynamic Young's modulus for this alloy also shows an increase in relative value near room temperature as the specimen approaches a state of complete order.

55. Kawamoto, M. and Nishioka, K.,
RESEARCH ON THE FATIGUE UNDER CONSIDERATION OF
THE PHENOMENON OF ELASTIC HYSTERESIS, Kyoto Uni-
versity Memoirs of the Faculty of Engineering, Vol. 17,
No. 1, January 1955, pp. 1-29.

This study deals with the relation between stress and strain of some metallic materials subjected to reversed stress and examines the condition of the fatigue limit. Also considered are the effect of shape of cross section of the specimen on fatigue limit and the relation between the form and notch factors.

56. Kê, T. S.,
INTERNAL FRICTION PEAKS ASSOCIATED WITH THE
TEMPERING OF MARTENSITE IN STEELS, Scientia Sinica,
Vol. 4, 1955, pp. 19-31.

Internal friction in hardened carbon steels was measured with a torsion pendulum. An internal friction peak was observed around 130° C when measurements were taken from room temperature upwards. This peak disappeared completely after the temperature of the specimen once reached 170° C. This phenomenon was observed in carbon steels containing carbon ranging from 0.29 to 1.4 percent, and also in an alloy steel. The appearance of this internal friction peak seems to indicate that the transformation product, the carbide, formed in the first-stage tempering of martensite is coherent with its parent phase, and the origin of internal friction is the stress-induced movement of the plane of coherence.

57. Kê, T. S., Tsien, C. T., and Mišek, K.,
ON THE INTERNAL-FRICTION PEAK ASSOCIATED WITH
THE PRESENCE OF CARBON IN NICKEL, Scientia Sinica,
Vol. 4, No. 4, December 1955, pp. 519-526.

This article describes experiments which demonstrate conclusively that this internal-friction peak is not connected with ferromagnetism of nickel, but depends upon the amount of carbon in solid solution in nickel. More accurate determinations of the activation energy associated with this internal-friction peak show that this activation energy is indeed very close to the activation energy for the diffusion of carbon in nickel.

58. Kê, T.S. and Wang, C. M.,
INTERNAL-FRICTION PEAKS ASSOCIATED WITH THE
STRESS-INDUCED DIFFUSION OF CARBON IN FACE-CEN-
TERED CUBIC ALLOY STEELS AND METALS, Scientia
Sinica, Vol. 4, No. 4, 1955, pp. 501-518.

Internal-friction peaks associated with the presence of carbon in several types of face-centered cubic alloy steel (18/8 type stainless steel and high manganese steel) have been observed between 200° and 300° C with a vibration frequency of approximately 1 cps. A comparison of the activation energy and the diffusion coefficient determined by internal-friction methods with those measured in conventional macrodiffusion experiments reveals that the observed internal-friction peak is associated with the stress-induced diffusion of carbon in these face-centered cubic steels. Internal-friction peaks associated with the stress-induced diffusion of carbon have also been observed in a nickel-aluminum alloy and in pure nickel.

59. Kê, T. S., Yung, P. T., and Wang, Y. N.,
DIFFUSION AND PRECIPITATION OF CARBON AND NITRO-
GEN FROM SOLID SOLUTION IN IRON AND STEEL, Scientia
Sinica, Vol. 4, 1955, pp. 263-276.

Diffusion and precipitation phenomena associated with embrittlement of iron and steel were studied by internal-friction measurements with a torsion pendulum. The diffusion of carbon or nitrogen in alpha-iron is not affected by carbon concentration below 0.017 percent or nitrogen concentration below 0.03 percent. Alloying elements have no effect on the diffusion of carbon, but retard the diffusion of nitrogen in alpha-iron. The 250° internal-friction peak is associated with strain aging or quench aging, and it occurs under conditions corresponding to the appearance of blue brittleness in steel. From data obtained during annealing of quenched specimens, temper brittleness of steel is attributed to the precipitation of nitrides instead of carbides.

60. Khilchevsky, V. V.,
AN INVESTIGATION OF THE ENERGY DISSIPATION IN
TURBINE-BLADE STEEL AT HIGH TEMPERATURES, Izv.
Kievsk. Politekhn. in-ta, Vol. 18, 1955, pp. 109-116.

The author investigates the decay decrement in turbine blade steel, Zh 1, at different temperatures. A description

is given of the experimental installation which enables oscillograms to be recorded for the pure bending of a sample at different temperatures. Curves are included showing the relationship between logarithmic decrement and stress at different temperatures from 20° to 600° C, and the dependence of decrement on temperature under fixed (constant) stress between 200 and 900 kg/cm².

61. Kirby, P. L.,
THE MECHANICAL RELAXATION OF ALKALI IONS IN A BOROSILICATE GLASS, Society of Glass Technology, Journal, Vol. 39, 1955, pp. 385_T-393_T.

The mechanical relaxation of the alkali ions in "Pyrex" brand borosilicate glass can be differentiated from the relaxation of the network-forming ions, and the connection between the former effect and the dielectric relaxation of the same group of ions is described. Experimental measurements are analyzed to show the distribution of relaxation periods in the system.

62. Kittel, C.,
AN ELECTRON TRANSFER MECHANISM FOR ULTRASONIC ATTENUATION IN METALS, Acta Metallurgica, Vol. 3, No. 3, May 1955, pp. 295-297.

This article suggests that groups of electrons in the superconducting state participate in the transfer process without interaction with lattice phonons, provision for energy conservation presumably being made by an internal energy of the group.

63. Klotter, K.,
THE ATTENUATION OF DAMPED FREE VIBRATIONS AND THE DERIVATION OF THE DAMPING LAW FROM RECORDED DATA, Second U. S. National Congress of Applied Mechanics, American Society of Mechanical Engineers, Proceedings, 1955, pp. 85-93.

An approximate method, known in nonlinear mechanics as the "Kryloff-Bogoliuboff Method," allows describing in closed form the attenuation of free damped vibrations for a large variety of damping laws, provided the damping forces are sufficiently weak. From the expressions for the attenuation, it is possible to derive rules for finding the damping law from a set of observed data.

64. Klotter, K.,
FREE OSCILLATIONS OF SYSTEMS HAVING QUADRATIC
DAMPING AND ARBITRARY RESTORING FORCES, Journal
of Applied Mechanics, Vol. 22, No. 4, 1955, p. 493.

This article investigates systems subjected to quadratic damping forces (of various magnitudes) and to restoring forces of any type. The differential equations of motion for such systems can be transformed into linear differential equations of first order for the velocity squared, whatever the restoring forces may be. A first integral can be obtained readily. From it the exact relationships between any two consecutive maximum displacement (amplitudes) are derived. These relationships are discussed in detail for various types of restoring forces. Examples are worked out numerically and illustrated by graphs.

65. Kneser, H. O., Magun, J., and Ziegler, G.,
DAMPING OF RODS OF SINGLE CRYSTAL ICE, Physika-
lische Verhandlungen Deutsche, Vol. 6, No. 3, 1955, p. 45.

Not abstracted.

66. Kneser, H. O., Magun, S., and Ziegler, G.,
MECHANICAL RELAXATION OF SINGLE CRYSTALS OF
ICE, Naturwissenschaften, Vol. 42, No. 15, 1955, p. 437
(In German).

Single crystals of ice one centimeter in diameter and five centimeters long, with c axis along the length of the crystal, showed a maximum damping at a frequency which varied with temperature according to an activation energy of 0.37 electron volts.

67. Komada, T.,
INTERNAL FRICTION OF WHITE TIN SINGLE CRYSTAL,
Nature, Vol. 175, 1955, p. 948.

Data are presented showing the amplitude dependence and the temperature dependence of the internal friction.

68. Koster, W.,
DAMPING CAPACITY MEASUREMENTS IN IRON RESEARCH,
Instituto del Hierro y Acero, Vol. 8, 1955, pp. 520-540.

Damping capacity studies of iron alloys over the last 15 years have yielded some results with interesting possibilities. Among others discussed are the measurement of the relation between temperature and carbon and (or) nitrogen solubility in the iron. In worked iron, the speed of precipitation of oxygen and nitrogen is greater than in nonworked material.

69. Koster, W. and Bangert, L.,
DETERMINATION OF THE DISLOCATION DENSITY IN
DEFORMED IRON, Acta Metallurgica, Vol. 3, 1955, pp. 274-276.

Damping-temperature curves were plotted in relation to foreign atoms in solid solution and the degree of cold work. A maximum damping value at 200° for a given degree of cold work reached a limiting value caused by the saturation concentration and permitted the determination of the change of the dislocation line density as a function of the degree of deformation.

70. Koster, W., Bangert, L., and Lang, W.,
DAMPING AND MODULUS OF SHEAR ELASTICITY OF
COPPER, Zeitschrift für Metallkunde, Vol. 46, 1955, pp. 84-89.

The temperature dependence of damping and of the modulus of elasticity of shear of deformed and recrystallized copper were investigated as a function of grain size up to 400°. A damping maximum is related to grain-boundary viscosity.

71. Kunz, F. W.,
THE SEGREGATION OF CARBON IN IRON SINGLE CRYSTALS AS STUDIED BY TORSION PENDULUM DAMPING,
Acta Metallurgica, Vol. 3, No. 2, March 1955, pp. 126-129.

This article presents a series of experiments on the effect of quenching and straining on the segregation of carbon in single crystals of alpha-iron.

72. Kvashnina, E. I. and Prosvirin, V. I.,
INTERNAL FRICTION OF TEMPER-(HOT)-BRITTLE STEEL,
Akademiya Nauk SSSR, Otdeleniye Tekhnicheskikh Nauk,
Izvestiya, No. 1, 1955, pp. 157-159.

This article contains measurements of internal friction of type 35KHG steel in the ductile and temper brittle conditions. Data were obtained for comparison on the effect of prolonged heating at 500° C on VT Mo-steel, in which temper brittleness does not exist. Internal friction of 35KHG steel increases due to the ferrite becoming denuded of carbon.

73. Lagenberg, G. and Josefsson, A.,
INFLUENCE OF GRAIN BOUNDARIES ON THE BEHAVIOR
OF CARBON AND NITROGEN IN α -Iron, Acta Metallurgica,
Vol. 3, No. 3, May 1955, pp. 236-244.

Internal friction is related to diffusion, solubility, and precipitation in solid solutions; grain size and boundary concentrations of carbon and nitrogen are studied.

74. Leak, D. A., Thomas, W. R., and Leak, G. M.,
DIFFUSION AND SOLUBILITY OF NITROGEN IN SILICON-
IRON, Acta Metallurgica, Vol. 3, No. 5, September 1955,
pp. 501-507.

Internal friction methods have been applied to a ternary alloy of iron, silicon, and nitrogen. Two relaxation peaks have been resolved. The peaks corresponding to jumps of the interstitial nitrogen atoms are connected with sites either 1) identical with those in pure α -iron, or 2) in octahedra containing one silicon atom along the tetrad axis.

75. Lee, E. H. and Bland, D. R.,
THE ANALYSIS OF DYNAMIC TESTS OF VISCOELASTIC
MATERIALS, Society of Plastics Engineers, Journal, Vol. 11,
No. 7, September 1955, pp. 28-35.

In this paper, methods of analysis of dynamic tests of viscoelastic materials are examined. It is shown that it is important to develop the analysis on the basis of a general stress-strain relation, because the particular form of the relation for the material under test is not known in advance, and any arbitrary assumption about it may lead to contradictions. Such a general method of analysis is discussed for a

simple longitudinal stress test, and for the vibrating reed test. References to the published literature indicate that such contradictions appear in currently accepted analyses, and their influence is detailed.

In seeking a viscoelastic model of springs and dashpots to represent the behavior of the material, the method presented separates the analysis of the test results from the determination of the appropriate model.

76. Levy, M. and Metzger, M.,
EFFECT OF HEAT TREATMENT ON THE INTERNAL FRICTION OF ALUMINUM CRYSTALS, Philosophical Magazine, Vol. 46, 1955, pp. 1021-1025.

The internal friction in quenched aluminum crystals at strain amplitudes 10^{-5} to 10^{-6} is much lower than in similar slowly cooled crystals. The results are in broad agreement with estimates of the effects expected of vacancies being trapped at dislocations.

77. Lewis, F. M.,
THE EXTENDED THEORY OF THE VISCOUS VIBRATION DAMPER, Journal of Applied Mechanics, Vol. 22, September 1955, pp. 377-382.

This article extends the theory of the viscous vibration damper, either tuned or untuned, to multimass systems and shows how an optimum damper can be designed for any installation. Special formulas are derived for the two-mass-plus damper systems.

78. Lindstrand, E.,
A METHOD FOR THE MEASUREMENT OF ELASTIC RELAXATION, AND ITS USE FOR DETERMINATION OF THE SOLUBILITY OF CARBON IN ALPHA-IRON, Acta Metallurgica, Vol. 3, No. 5, September 1955, pp. 431-435.

Spiral samples twisted through certain angle and released are tested photographically for creep.

79. Lowe, R.,
SELECTING VIBRATION ISOLATORS, Product Engineering, Vol. 26, September 1955, pp. 184-185.

This article discusses a five-point design procedure for the general case of disturbing amplitudes in the vertical

direction. Also, the article discusses 11 typical isolators covering loads from ounces to tons and employing woven wire, rubber in shear and compression, conical springs with air damping, and combinations of wire mesh and springs.

80. Macinante, J. A.,
SURVEY ON VIBRATION AND SHOCK ISOLATION, Commonwealth Scientific and Industrial Research Organization, National Standards Laboratory, Melbourne, Australia, 1955, p. 42.

The second part is concerned with the isolation of vibration. Protective mounting of instruments and precision machine tools is discussed.

81. Mackinnon, L.,
RELATIVE ABSORPTION OF 10 mc/sec LONGITUDINAL SOUND WAVES IN A SUPERCONDUCTING POLYCRYSTALLINE TIN ROD, Physical Review, Vol. 100, No. 2, 15 October 1955, pp. 655-659.

The relative absorption of 10 mc/sec sound pulses has been studied between 1.5° and 3.73° K (the transition temperature) in superconducting polycrystalline tin and above 3.73° K to about 4.2° K in the normal metal. Above the transition, the absorption was heavy, but below it, the absorption decreased considerably as the temperature was lowered.

82. Makorova, V. I.,
DETERMINATION OF THE MODULUS OF ELASTICITY FOR TORSIONAL VIBRATIONS, Zavodskaya Laboratoriya, Vol. 21, 1955, pp. 354-355 (In Russian).

The simple method described for the determination of moduli of elasticity is based on the measurement of the number of torsional oscillations executed in a given time. Values obtained for steel test tubes are given.

83. Mason, W. P.,
ULTRASONIC ATTENUATION DUE TO LATTICE-ELECTRON INTERACTION IN NORMAL CONDUCTING METALS, Physical Review, Vol. 97, No. 2, 16 January 1955, pp. 557-559.

The purpose of this article is to point out that a simple phenomenological concept of the interaction between lattice

vibrations and the electron gas gives values of attenuations which agree with the measured values (H. E. Bömmel, Physical Review, Vol. 9, 1954, p. 220). The concept considered is that a lattice vibration in the normal state can communicate energy to the electron gas by a viscous reaction (transfer of momentum) and is damped by the viscosity of the gas; whereas, the lattice in the superconducting state is not capable of transferring momentum to the electron gas, and the damping disappears.

84. Mason, W. P.,
RELAXATIONS IN THE ATTENUATION OF SINGLE CRYSTAL LEAD AT LOW TEMPERATURES AND THEIR RELATION TO DISLOCATION THEORY, Acoustical Society of America, Journal, Vol. 27, July 1955, pp. 643-653.

Measured results correlate well with a relaxation due to the displacement of a dislocation from one atomic line to an adjacent one against the limiting shearing stress of the crystal.

85. Mason, W. P., DISLOCATION RELAXATIONS AT LOW TEMPERATURES AND THE DETERMINATION OF THE LIMITING SHEARING STRESS OF A METAL, Physical Review, Vol. 98, 1955, pp. 1136-1138.

The values obtained agree with a displacement of a dislocation from a minimum energy position in a close-packed glide plane by one atomic spacing against the limiting shearing stress of the crystal.

86. Mason, W. P.,
EFFECT OF DISLOCATIONS ON ULTRASONIC WAVE ATTENUATION IN METALS, Bell System Technical Journal, Vol. 34, 1955, p. 903.

It is shown that the primary causes of energy dissipation in a metal are dislocation loops pinned at irregular intervals by impurity atoms. By measuring the position and height of the relaxation peaks as a function of frequency and temperature, evidence is obtained for the value of the limiting shearing stress, the number of dislocations per square centimeter, and the average loop length.

87. Mayer, G. and Gigon, J. ,
ULTRASONIC MEASUREMENTS OF THE ELASTIC CON-
STANTS OF SOLIDS, Journal de Physique et le Radium,
Vol. 16, No. 8-9, August-September 1955, pp. 704-706.

A process for the emission of acoustical waves in gasses provides a new method for measuring the Young and Poisson moduli and the internal friction of solids.

88. McCallion, H. and Davies, D. M. ,
BEHAVIOR OF RUBBER IN COMPRESSION UNDER DYNAMIC
CONDITIONS, Institution of Mechanical Engineers, Proceed-
ings (London), Vol. 169, 1955, pp. 1125-1140.

Experimental data show the variation of stiffness, hys-teresis energy absorbed per cycle, and resilience, with fre-
quency, amplitude of deformation, and temperature. The
data cover the following ranges: 1) frequency was 1.33 to
1200 cpm, 2) amplitude was 0-10 percent of the free length
of the test piece, and temperatures were from 125° to -60°.

89. Miki, H. ,
CHANGE OF INTERNAL FRICTION DUE TO METAL
FATIGUE, Engineering Research Bulletin of the Kyoto
University, Vol. 17, 1955, pp. 1-29 (In Japanese).

The logarithmic decrement due to internal friction is
also influenced by the measurement frequency, and observa-
tions over a wide range of frequency are needed to assess the
internal state of a metal adequately. From rotating bending
fatigue tests on a 0.1 percent carbon steel wire rod, it is
concluded that the intercrystalline strain gradient induced
by repeated stress is more important than structural imper-
fections in producing fatigue failure.

90. Mišek, K. ,
MAGNETIC INTERNAL FRICTION PEAK IN NICKEL,
Czechoslovak Journal of Physics, Vol. 5, 1955, p. 420.

The damping behavior of nickel in an alternating mag-
netic field is described. The effect depends upon tempera-
ture, carbon content, frequency, and cold work.

91. Morse, R. W.,
ULTRASONIC ATTENUATION IN METALS BY ELECTRON
RELAXATION, Physical Review, 1955, pp. 1716-1777.

Bömmel has reported a difference in the ultrasonic attenuation between lead in the normal and superconducting states. The magnitude and temperature dependence of the attenuation in the normal state can be explained reasonably in terms of an incomplete adjustment of the Fermi distribution with respect to the elastic deformation. Such an attenuation is to be expected in all metals at low temperatures when the mean free path becomes relatively long.

92. National Advisory Committee for Aeronautics, Washington, D. C.,
THEORETICAL INVESTIGATION OF FLUTTER OF TWO-DIMENSIONAL FLAT PANELS WITH ONE SURFACE EXPOSED TO SUPERSONIC POTENTIAL FLOW by H. C. Nelson and H. J. Cunningham, July 1955, Report No. TN 3465.

The authors have devised a Rayleigh flutter analysis using Galerkin's process for a two-dimensional flat panel held in various ways at its leading and trailing edges and acted on by midplane forces. Using the normal modes of the panel as degrees of freedom, and making use of linearized unsteady aerodynamic forces, numerical results are obtained. The effects of number of modes considered, Mach number, density of the supersonic stream, density of the still air below the panel, panel mass and stiffness, and structural damping are examined to a certain extent.

93. Nohara, S.,
VISCOELASTIC PROPERTIES OF HIGH POLYMERS. VII. HETEROGENEOUS SYSTEMS, Chemical High Polymers, Japan, Vol. 12, 1955, pp. 527-534.

From an equation for viscoelastic behavior of the heterogeneous systems obtained previously by the same author, E^* and mechanical loss factor are derived for the mixtures of two polymers and of polymer and filler.

94. Nowick, A. S.,
THE INTERPRETATION OF LOW-TEMPERATURE RECOVERY PHENOMENA IN COLD-WORKED METALS, Acta Metallurgica, Vol. 3, 1955, pp. 312-321.

From a survey of various low-temperature recovery phenomena, it is concluded that both annealing out-of-point defects and regrouping of dislocations occur in the very early stages of annealing. Electrical resistivity seems to be the most sensitive to point defects, while internal friction and elastic modulus are affected most by the earliest stages of the rearrangement of dislocations. Considerable dislocation recovery takes place at room temperature in very short times after deformation, even for very high melting point metals.

95. Ochsenfeld, R.,
THE DAMPING OF IRON-NICKEL ALLOYS, Zeitschrift für Physik, Vol. 143, No. 3, 1955, pp. 357-373.

This article reports measurements of logarithmic decrement of iron-nickel strips with nickel contents between zero and 60 percent; flexural oscillations, as dependent on the frequency (200 to 1300 cps); strain amplitude; and applied field strength.

96. Ochsenfeld, R.,
MAGNETO-ELASTIC PROPERTIES OF CERTAIN FERRO-MAGNETIC IRON-NICKEL ALLOYS, Zeitschrift für Physik, Vol. 143, No. 4, 1955, pp. 375-391.

The delta-E effect depends not only on magnetizing conditions but on the magnetic reversal which is automatically produced during the experiment.

97. Palme, R. and Scheiber, W.,
CONTRIBUTION TO MEASUREMENT OF ELASTIC MODULUS AND ATTENUATION OF SINTERED MATERIALS, Planseeberichte für Pulvermetallurgie, Vol. 3, No. 3, December 1955, pp. 87-95.

This article presents an improved arrangement for E-modulus determination of samples of alloyed and unalloyed sinter iron.

98. Pippard, A. B.,
ULTRASONIC ATTENUATION IN METALS, Philosophical Magazine, Vol. 46, No. 381, 1955, pp. 1104-1114.

The attenuation of ultrasonic waves by conduction electrons is analyzed in terms of the free-electron model of a metal. The drop in attenuation observed when a metal becomes superconducting is shown to present quite serious problems of interpretation, and tentative suggestions are made as to possible explanations.

99. Pisarenko, G. S.,
THE OSCILLATIONS OF ELASTIC SYSTEMS IN THE PRESENCE OF DISSIPATION OF ENERGY IN THE MATERIAL, Kiev, Izd-vo. Akad. Nauk SSSR, 1955, 239 pp.

An analytical and experimental investigation is presented of vibrations of nonconservative elastic systems in which the source of energy dissipation is irreversible cyclic straining of the material. Modern methods of analysis of nonlinear vibrating systems are extended to treat problems of the flexural vibrations of long bars of constant and variable cross section, short bars, and turbine blades. Torsional vibrations of rods are also considered.

100. Pisarenko, G. S.,
FREE VIBRATIONS OF A LOAD ON A BEAM, WITH CONSIDERATION OF HYSTERESIS LOSSES, Izv. Kiyevsk. politekhn. in-ta, Vol. 18, 1955, pp. 3-13.

The free-damped vibrations of a concentrated load on the end of a weightless cantilever beam are investigated. The nonelastic reaction forces are assumed to be independent of the deformation velocity.

101. Pitsch, W.,
THE SHAPE OF PARTICLES DURING PRECIPITATION OF CARBIDE IN ALPHA-IRON, Acta Metallurgica, Vol. 3, 1955, pp. 542-548.

Internal friction and electrical resistivity measurements yielded a parameter solely dependent on particle shape. From the data, the values of the deduced parameter indicate that the precipitated particles are platelike. During precipitation, the ratio "plate-diameter:plate-thickness" decreases.

102. Powers, R. W.,
INTERNAL FRICTION IN SOLID SOLUTIONS OF OXYGEN-
TANTALUM, Acta Metallurgica, Vol. 3, 1955, pp. 135-139.

The breadth of the Q^{-1} peak arising from the diffusion of oxygen in tantalum has been found to increase monotonically with oxygen concentration. The data can be described by assuming that the Q^{-1} peak is a compost of the dilute oxygen peak at 137° C (for 0.6 cps), and a second peak located near 162° C. Evidence is presented which indicates that the peak previously attributed to carbon in tantalum actively is caused by oxygen at cast concentration.

103. Rawlings, R. and Tambini, D.,
NITROGEN IN IRON ANELASTICITY AND SOLID SOLUBIL-
ITY, Acta Metallurgica, Vol. 3, 1955, pp. 212-213.

Data are presented which show the relation between the height of the Snoek peak and the nitrogen content.

104. Richards, D. A.,
FORCED VIBRATION WITH DAMPING, American Journal
of Physics, Vol. 23, No. 9, December 1955, pp. 557-561.

This article describes the experimental determination of the response curves for forced vibration with velocity damping, using a moving-coil galvanometer. Experimental results obtained with the apparatus, both for response curves and phase angle measurements, and for various values of damping, are summarized in the paper.

105. Rubber Laboratory, Mare Island Naval Shipyard, Vallejo,
California,
TRANSMISSIBILITY OF MECHANICAL VIBRATING THROUGH
NEOPRENE GRT AND NATURAL RUBBER MOUNTING
STOCKS, 27 June 1955, Technical Report 9-56, p. 12.

This report presents a description of an apparatus for measuring the transmissibility of mechanical vibrations, and contains information relative to damping characteristics of rubber mounts.

106. Sacerdote, C. B.,
MEASUREMENTS UPON DAMPING MATERIALS, R. C. 55,
Ruin Assoc. Elettrotec. Ital., Bellagio, 1954, Vol. 42,
Fascicle 2, Paper 162, 1955, p. 8 (In Italian).

A brief description of the vibration technique used, and a review of the work of other authors, are given. The parameters involved are defined, and their experimental behavior and the results obtained are discussed in detail, using graphs of the functions. Oscillographs and photographs of the higher modes of vibration of square plates are included.

107. Sacerdote, G. G.,
AN ACOUSTICAL METHOD FOR THE MEASUREMENT OF
DISSIPATIVE PARAMETERS OF A TREATED VIBRATION
PLATE, ATA, February 1955, Vol. 6, No. 5, pp. 401-407.
(In Italian).

Not abstracted.

108. Salceanu, C.,
VARIATION OF VISCOSITY OF METALLIC WIRES WITH
TEMPERATURE, Comptes Rendus, Vol. 241, No. 20,
14 November 1955, pp. 1384-1386.

Study of the effect of temperature on the viscosity of iron wire, working with a moment of inertia of 970 grams per square centimeter.

109. Salceanu, C.,
THE VISCOSITY OF METALLIC WIRES (La Viscosity des
Fils Metalliques), Comptes Rendus, Vol. 241, No. 12, 19
September 1955, pp. 734-736.

This article describes an apparatus for measuring based on the determination of the time necessary to reduce half the initial amplitude of the oscillations of a torsion pendulum, whose suspension wire is aluminum.

110. Salceanu, C.,
VISCOSITY AND INTERNAL FRICTION IN METALLIC
WIRES, Comptes Rendus, Vol. 241, No. 22, 28 November
1955, pp. 1554-1555.

Measurement determination in steel and aluminum wires is discussed.

111. Samuel Feltman Ammunition Laboratories, Picatinny Arsenal, Dover, New Jersey,
DEVELOPMENT OF VIBRATING TECHNIQUES FOR MEASURING PROPERTIES OF POLYMERS, Ordnance Project TB-2-001, 1955.

Not abstracted.

112. Schnittger, J. R.,
THE STRESS PROBLEM OF VIBRATING COMPRESSOR BLADES, Journal of Applied Mechanics, Vol. 22, No. 1, March 1955, pp. 57-64.

To demonstrate the general nature of the actual vibrations of compressor and turbine blades, the author undertakes a simplified analysis in which a single stiff blade, with one translational and one pitching mode, is studied. It is shown that all problems of stress in vibrating compressor blades, whether they arise from forced or self-sustained vibrations, may be related to the magnitude of finite mechanical or aerodynamic disturbances. The discussion is a comparison of the order of magnitude of the damping in the blade holder and the internal damping with the magnitude of the damping of the aerodynamic reactions. The structural damping for advanced designs appears to be of the order of 10 to 20 percent of the total damping.

113. Seemann, H. J.,
DESCRIPTION OF A UNIVERSAL APPARATUS FOR ELASTIC DAMPING OF METALS. APPLICATIONS TO ALUMINUM, Revue de Métallurgie, Vol. 52, No. 11, November 1955, pp. 864-868.

Equipment to gage elastic damping capacity of metals over a spread of frequency, temperature, and deformation amplitude applied to 99.997 percent aluminum.

114. Settles, J. C.,
APPLICATION OF DYNAMIC VIBRATION ABSORBER TO VEHICLES, National Congress of Applied Mechanics, 2nd Proceeding, Vol. 1954, 1955, pp. 111-119.

This paper deals with the use of dynamic vibration absorbers for simultaneous control of forced linear and rotational motions of vehicles or similar systems.

115. Shil'krut, D. I.,
ON THE RELATIONSHIP BETWEEN THE LOGARITHMIC
DECREMENT OF DAMPING AND THE RELATIVE DAMP-
ING OF THE AMPLITUDE OF THE POTENTIAL ENERGY
(CYCLIC VISCOSITY), Doklady Akademii Nauk SSSR, Vol.
104, No. 2, 1955 (In Russian).

Not abstracted.

116. Smithells, C. J.,
METALS REFERENCE BOOK, Interscience Publishers,
Incorporated, Vols. I, II, 1955.

This set is a convenient and comprehensive summary of a wide range of physical, mechanical, and electrical data relating to metallurgy and metal physics. In this new edition, values have been updated where more recent and reliable information has become available. Several sections have been added covering elastic properties and damping capacity, physical properties of molten salts, and friction. Presentation is largely in tabular form, with brief monographs included where information could not otherwise be adequately given. In Volume II, there is a chapter dealing with "Elastic Properties and Damping Capacity."

117. Soroka, W. W.,
CLACULATING ROCKING RESPONSE OF VIBRATION-
ISOLATED EQUIPMENT, Product Engineering, Vol. 26,
December 1955, pp. 162-167.

When equipment subjected to dynamic loads is mounted on flexible mounts, a rocking motion (combined rotation and translation) results which is a function of the spring constant of the mounts. An analysis of the dynamic response of the equipment, therefore, helps determine: (1) the effectiveness of the mounts, (2) the proper clearances around the equipment, (3) the acceleration forces on equipment accessories, and (4) the forces transmitted into the foundation.

118. Stanley, J. T. and Wert, C. A.,
INTERNAL FRICTION OF INTERSTITIAL SOLID SOLUTIONS
OF OXYGEN AND NITROGEN IN VANADIUM, Acta Metal-
lurgica, Vol. 3, No. 1, January 1955, pp. 107-108.

This paper deals with the effects of carbon, nitrogen, and oxygen on damping peaks in ductile vanadium.

119. Stevens, S.,
SKIS, ANY WAY YOU WANT 'EM, Ski, Vol. 19, No. 5,
February 1955, pp. 20, 26-27.

A research physicist reports the results of experiments designed to measure the torsional rigidity and damping of various types of skis. Laminated aluminum, wood, and metal top-and-bottom with wood core types of construction were tested. All wood skis have approximately the same damping. Some laminated woods have about twice the damping of solid woods. Laminated aluminum exhibits damping not very different from wood, but gives greater damping than many wood skis at larger amplitudes and smaller at the lesser amplitudes. The ski with the metal top-and-bottom enclosing a wood core has very little damping. The desirable damping requirements of a good ski are as yet unknown and present a topic for future study.

120. Sugeno, T. and Kowaka, M.,
THE BACKGROUND INTERNAL FRICTION IN PALLADIUM CHARGED WITH HYDROGEN, Institute of Scientific and Industrial Research, Osaka University Memoirs, Vol. 12, 1955, pp. 41-45.

The internal friction of 99.8 percent pure palladium wire of different grain sizes charged with hydrogen was measured at room temperature. The internal friction increased with increasing charging time. In the extreme case, where the grain size was greater than the diameter of the specimen, the internal friction did not change with charging time. The value for the internal friction was greatest immediately after charging and then decreased with time. The origin of this background internal friction may be the interaction between the grain boundaries or similar lattice irregularities and the hydrogen atoms.

121. Tabor, D.,
THE MECHANISM OF ROLLING FRICTION-II. THE ELASTIC RANGE, Royal Society Proceedings, Series A, Vol. 229, 1955, pp. 198-220.

This paper discusses the mechanism of rolling friction under conditions where the deformations involved are predominantly elastic. Experiments on the rolling of a metal cylinder over a rubber surface show that interfacial slip

of the type described by Reynolds is minute and totally insufficient quantitatively and that the rolling resistance under these conditions is due to elastic hysteresis losses in the rubber.

122. Tanaka, K., Abe, H., and Hirano, K.,
THE MECHANISM OF AGING IN ALUMINUM-SILVER
ALLOYS. III. VARIATION OF THE YOUNG'S MODULUS,
Physical Society of Japan, Journal, Vol. 10, 1955, pp. 454-
458.

Variations of the Young's modulus and the internal friction during the aging of the supersaturated solid solution of 20 percent by weight silver in aluminum were examined on polycrystalline samples by the high-frequency method at about 13 kc/sec. Both isothermal aging curves and heating curves were obtained. Temperature variations of the Young's modulus and the internal friction were also measured on pure aluminum and compared with those for the silver-aluminum alloy.

123. Tanaka, K., Abe, H., and Hirano, K.,
YOUNG'S MODULUS OF AGE-HARDENED ALUMINUM
ALLOYS, Ochanonizu University Natural Science Report,
Vol. 5, 1955, pp. 213-227.

Variations of the Young's modulus and of the internal friction during the aging of 20 percent silver-aluminum, 30 percent zinc-aluminum, and four comparisons of copper-aluminum alloys were determined by a high-frequency method at about 13 kc/sec. At room temperature some increase in internal friction due to aging was noted for the zinc-aluminum alloys, but not for the others.

124. Tanttila, W. H.,
INFLUENCE OF ULTRASONIC ENERGY ON RELAXATION
OF CHLORINE NUCLEI IN SODIUM CHLORATE, University
Microfilms Publication No. 14263, 1955, 47 pp; Dissertation
Abstracts, Vol. 15, 1955, p. 2554.

An investigation of the direct and indirect thermal relaxation of Cl^{35} in a single crystal of NaClO_3 has been made using pulsed techniques. The temperature dependence of the indirect process has been measured and the experimental results are compared with the theoretical results of

Chang. The agreement is good. The direct process has been studied by means of introducing into the crystal ultrasonic energy at a frequency equal to the transition frequency between the two quadrupolar energy levels of the Cl^{35} nucleus. The agreement between the theoretical dependence of the direct process relaxation time and the experimental relaxation time as a function of the energy density of the transition-frequency lattice vibrations is poor.

125. Thomas, W. R. and Leak, G. M.,
THE BINDING ENERGY OF NITROGEN IN A DISLOCATION,
Physical Society, Proceedings, Vol. 68, No. 12-B, 1955,
pp. 1001-1007.

The solubility of nitrogen has been measured in annealed and cold-worked alpha-iron by Q^{-1} . N_2 in annealed iron has a heat of solution 0.26 electron volt per nitrogen atom. Bonding energy in dislocation is from 0.75 to 0.8 electron volt per nitrogen atom.

126. Thomas, W. R. and Leak, G. M.,
THE STRAIN AGING OF ALPHA-IRON, Iron and Steel
Institute, Journal, Vol. 180, June 1955, pp. 155-161.

Rates of strain aging on specimens containing only nitrogen and on those containing only carbon are determined by both internal friction and yield-stress measurements. Both methods give identical information about the mechanism.

127. Thomas, W. R. and Leak, G. M.,
CONDITION OF BORON IN ALPHA-IRON, Nature, Vol. 176,
1955, p. 29.

Snoek-type peaks in alpha-iron are interpreted as due to boron in interstitial solid solutions. Estimates are made of the difference coefficient and the activation energy for diffusion.

128. Thompson, D. O., Holmes, D. K., and Blewett, T. H.,
NEUTRON IRRADIATION EFFECTS UPON YOUNG'S
MODULUS AND INTERNAL FRICTION OF COPPER,
Journal of Applied Physics, Vol. 26, No. 9, September
1955, p. 1188.

The modulus of copper crystals grown from the melt increases by a few percent after neutron fluxes as low as

10^{14} nvt. The decrement, measured at 20 kc/sec, decreases sharply on irradiation. The results suggest that the vacancies or interstitials lock dislocations so they cannot decrease the modulus or contribute to the damping by their motion.

129. Truell, R.,
ULTRASONIC ATTENUATION MEASUREMENTS FOR STUDY
OF THE ENGINEERING PROPERTIES OF MATERIALS,
Mechanical Engineering, Vol. 77, July 1955, pp. 585-587.

Brief details are given of the evaluation of ultrasonic energy losses in solids by the measurement of attenuation or propagation factor. The use of attenuation measurements in specific researches into the properties of some engineering materials is described.

130. United States Bureau of Mines,
CASTING AND FABRICATION OF HIGH DAMPING
MANGANESE-COPPER ALLOYS by J. A. Rowland, C. E.
Armantrout, and D. F. Walsh, April 1955, Report of
Investigations No. 5127.

Manganese-copper alloys containing 60 percent or more electrolytic manganese exhibit an unusual combination of high vibration damping capacity with good strength properties. However, serious difficulties encountered in commercial fabrication of structural or machine components from these alloys retarded attempts at their practical utilization. For this reason the United States Bureau of Mines undertook a program designed to develop practical methods for fabricating a selected group of high damping alloys. It is the purpose of this report to summarize a part of that investigation in a form that is suitable for use by the metallurgist interested in commercial fabrication of the alloys.

131. Vitovec, F. H. and Lazan, B. J.,
STRENGTH, DAMPING, AND ELASTICITY OF MATERIALS
UNDER INCREASING REVERSED STRESS WITH REFERENCE
TO ACCELERATED FATIGUE TESTING (U), American
Society for Testing Materials, Proceedings, Vol. 55, 1955,
pp. 844-865 (Unclassified).

The purpose of the work was to investigate the damping, stress-strain, and failure properties under uniformly increasing stress amplitude and to determine the relation of

these properties to conventionally determined fatigue strength. Data are presented on SAE 1020 steel, 2024-Tr aluminum alloy, SAE 4340 steel, and RC-55 titanium under rotating-bending stress amplitudes which are progressively increased during the test and are held constant as in conventional fatigue tests.

132. Voelz, K.,
THEORY OF INTERNAL DAMPING OF VIBRATING SOLIDS,
Abhandlungen der Braunschweigischen, Vol. 6, 1955, pp. 126-165 (In German).

Not abstracted.

133. Volger, J., Stevels, J. M., and Van Amerongen, C.,
DIELECTRIC LOSSES OF VARIOUS MONOCRYSTALS OF QUARTZ AT VERY LOW TEMPERATURES, Philips Research Report, Vol. 10, 1955, pp. 260-280.

Between 14 percent and 150° K the tangential δ versus T curve of quartz measured at frequencies of 1 to 32 kc/sec, may show a variety of maxima. The relaxation phenomena involved are correlated with both primary and radiation-induced lattice defects. Results of experiments with clear quartz, artificially irradiated quartz, natural smoky quartz, and amethyst are reported. A discussion related to the nature of a number of lattice imperfections is given.

134. von Kappeler, F.,
KAUTSCHUKVULKANISATE ALS DAMPFUNGSMATERIAL IM MASCHINENBAU, Schweizer Archiv für Angewandte Wissenschaft und Technik, Vol. 21, January 1955, pp. 8-19.

This article indicates successful use of rubber compounds for damping purposes in mechanical engineering.

135. Wada, Y.,
VELOCITY OF ULTRASONIC WAVES IN HIGH POLYMERS. I, II., Oyo Butsuri, Vol. 24, 1955, pp. 159-163.

I. The variation of ultrasonic velocity with temperature in polymethyl methacrylate and polystyrene was measured between zero and 90° C by the total reflection method at frequencies 1.46, 4.38, and 7.30 mc/sec.

II. The velocity and absorption of ultrasonic waves (1.46 mc/sec) were measured for nylon-6, polyvinyl chloride, celluloid, ebonite, polyethylene, phenol resin, and Bakelite at temperatures between 10° to 90° C.

136. Watanabe, M., Satoh, K., Minehisa, S.,
SOME EXPERIMENTS ON THE VIBRATION CHARACTER-
ISTICS OF WELDED JOINTS, Osaka University Technology
Report, Vol. 5, No. 154, 1955, pp. 177-184.

The effect of residual stress on the vibration character-
istics of welded joints was studied, using the so-called H-
type constrained welded specimens. Residual stress
decreased with increase in the number of vibrations to which
the welded samples were subjected, and the value of the
stress relieved increased with amplitude of vibration.

137. Watari, A.,
DRY FRICTION DAMPER AND ITS CONDITION OF TUNING,
University of Tokyo Institute of Industrial Science Report,
Vol. 5, No. 2, Serial No. 36, August 1955, pp. 26-36.

The performances of the Lanchester damper with dry
friction are discussed in detail, and the condition of tuning
is analyzed and compared with that of the Lanchester damper
with viscous friction.

138. Weertman, J.,
INTERNAL FRICTION OF METAL SINGLE CRYSTALS,
Journal of Applied Physics, Vol. 26, February 1955, pp. 202-
210.

Semiquantitative calculations are presented for that
portion of the internal friction of annealed and moderately
cold-worked metal single crystals which is due to disloca-
tion motive.

139. Weertman, J. and Salkovitz, E. I.,
THE INTERNAL FRICTION OF DILUTE ALLOYS OF LEAD,
Acta Metallurgica, Vol. 3, No. 1, January 1955, pp. 1-9.

This article presents effects of strain amplitude,
temperature and ratio of atom sizes on internal friction,
modulus of elasticity and critical shear stress in 0.01 to
0.1 percent bismuth, tin, or cadmium alloys.

140. Weinig, S.,
HIGH-VACUUM TORSIONAL PENDULUM FOR ANELASTIC
STUDIES, Review of Scientific Instruments, Vol. 26, 1955,
pp. 91-92.

This paper describes a high vacuum internal friction apparatus by means of which a wire specimen may be studied without manual manipulation of the sample or reduction of vacuum in the system from a time prior to annealing until completion of the test. Results are presented for tests on two annealed high-purity copper-aluminum alloys with the decrement being measured at 50° C. The frequency ratio used was $f_1/f_2 = 2.85$. Within the experimental accuracy, no variation in logarithmic decrement was found. A decrease of internal friction with increased solute which was observed in these tests is due to the pinning down of dislocations in the metal.

141. Wert, C. A.,
INTERNAL FRICTION OF AN ALLOY OF 16 PERCENT
ALUMINUM IN IRON, Journal of Applied Physics, Vol. 26,
May 1955, pp. 640-641.

The results of measurements of the internal friction of "16 Alfenol" are presented. No damping peaks were observed which could be identified as being associated with interstitial impurities. However, some interesting damping effects of different origins were found. These are believed due to stress relaxation in the grain boundaries, to stress induced ordering, and to an effect probably magnetic in origin. A torsion pendulum was used for the measurements. A graph of damping as a function of temperature is shown.

142. Wright Air Development Center, Wright Patterson Air Force
Base, Ohio,
EFFECT OF MATERIAL DAMPING AND STRESS DISTRI-
BUTION ON THE RESONANT FATIGUE STRENGTH OF
PARTS by E. R. Podnieks and B. J. Lazan, August 1955,
Report No. TN55-284.

The behavior of various types of parts under resonant vibrations is reviewed considering material hysteresis as the only form of damping present. Three different criteria (total damping, resonance amplification factor, and resonant exciting stress) are introduced for comparing materials and

parts for resonant operation. The relationship of stress distribution to the shape of the damping energy curves and the resultant effect on the above criteria are discussed. The influence of the cyclic stress history on resonant behavior is also indicated. In comparative examples, the relative merits of five different types of structural materials (type 403 alloy, RC-55 titanium annealed, RC-55 cold-worked, RC-130B, and glass fabric laminate) based on the above criteria are discussed in connection with application to various types of parts. Resonant fatigue curves are introduced and discussed for the same examples.

143. Aeronautical Research Institute of Sweden,
A METHOD FOR THE DETERMINATION OF THE DAMPING-
IN-PITCH OF SEMI-SPAN MODELS IN HIGH-SPEED WIND
TUNNELS, AND SOME RESULTS FOR A TRIANGULAR WING
by K. Orlik-Ruckemann and C. O. Olsson, Report No. 62,
1956.

A method was developed for the determination of the damping-in-pitch of semi-span models in high-speed wind-tunnels using the free oscillation technique. The model was mounted elastically by means of a torsion bar with cruciform section. The initial oscillation amplitude was built up electromagnetically, after which the disconnection of the energy source results in a free oscillation, which was automatically evaluated on a special electronic apparatus, called the "Dampometer."

144. Anonymous,
CALCULATING DAMPING FACTORS FOR DASHPOT
DAMPERS, Product Engineering, April 1956, pp. 162-165.

This article presents equations for determining the damping factors of linear and rotary dashpot dampers on the basis of their dimensions and the viscosity of the damping fluid. With the equations developed, designs may be synthesized on paper instead of using models requiring test and modification.

145. Anonymous,
DOUBLE DAMPING CUTS VIBRATION HARM IN AIRCRAFT,
Industrial Laboratories, Vol. 7, June 1956, p. 114.

Research on vibration protection and equipment stability in aircraft and missiles by the K. W. Johnson and Company, Incorporated, Dayton, Ohio, has resulted in Johnson metal mounts, a double damping system where a circular coil spring tempers motion of a convex-concave spring to life efficiency of damping to a reported 95 percent.

146. Anonymous,
LOW OR HIGH FREQUENCY VIBRATIONS ABSORBED.
MOUNTING REDUCES NEED FOR CONCRETE FOUNDATION,
Engineering, Vol. 182, 13 July 1956, p. 46.

A description of the Cushyfoot antivibration mounting introduced by Metalastik Limited, Evington Valley Road, Leicester, England.

147. Anonymous,
REPORT ON TESTS WITH THE SPRAY MATERIAL
"SCHALLSCHLUCK" (OR "AQUAPLAS" IN U. S. A.),
H. L. Blachford, Inc., News Service, Newark, New
Jersey, 20 July 1956.

The substance Aquaplas was sprayed on wheel discs and bogie components of German Federal Railway carriages for the damping of structure-borne sound. The material was found to have good laboratory properties and to reduce considerably the air-borne and structure-borne sound in the carriages. Attenuation measurements were made to determine the effectiveness of the substance as a high damping material.

148. Anonymous,
RUBBER-BALL MOUNTING, Machine Design, Vol. 28,
14 June 1956, p. 98.

The use of neoprene balls in mounting of oscillating plate members minimizes the effects of vibration and reduces operation noise of a portable electric sander developed by the Thor Power Tool Company.

149. Anonymous,
THE TAILOR GOES TO METALS. WESTINGHOUSE
SCIENTISTS PREDICT PROPERTIES OF NEW ALLOY:
THEN PROVE IT WORKS, Chemical and Engineering News,
Vol. 34, 16 July 1956, p. 3504.

Nivco, a "super alloy," has the ability to kill the mechanical vibration which comes from control of the magnetic arrangement of atoms in the alloy.

150. Anonymous,
THE USE OF SOUND-DEADENING COATINGS IN THE FIELD
OF NOISE CONTROL, News Service. H. L. Blachford,
Incorporated, Newark, New Jersey, 1956.

In this article, the engineering importance of sound-deadening coating is emphasized. The available materials for such coatings are reviewed. Based on decrement and attenuation measurements, it is shown that Aquaplas is superior to the others. A decay rate of up to 50 decibels per second is possible.

151. Atomic Energy Commission,
SOME OBSERVATIONS ON THE RELATIONSHIP BETWEEN
FATIGUE AND INTERNAL FRICTION by S. R. Valluri,
1956. Report No. NACA-Tn-3755.

Results are presented of an investigation made to determine the internal friction and fatigue strength of commercially pure 1100 aluminum under repeated stress in torsion at various temperatures and stress levels in an effort to find if there exists any correlation between internal friction and fatigue characteristics.

152. Atomic Energy Commission,
A STUDY OF INTERNAL FRICTION AND TWIN-BOUNDARY
MOVEMENT IN URANIUM by R. E. Maringer, L. L. Marsh,
and G. K. Manning, 30 January 1956, Contract No. W-7405-
eng-92, 34 pp.

The internal friction of recrystallized uranium was shown to depend directly on heating and cooling rates and on the rate of application or removal of an external stress during measurement. At zero heating or stress rate, the internal friction falls to a low value and appears to decrease indefinitely at room temperature. It is concluded that the various internal-friction phenomena are the result of the stress-induced motion of twin boundaries.

153. Baccaredda, M., Bordoni, P. G., Butta, E., and Charlesby, A.,
ELASTIC AND ANELASTIC BEHAVIOR OF SOME IRRADIATED HIGH POLYMERS, Chemische Industrie, Vol. 38, 1956, pp. 561-570.

The effect of radiation on polymers is to produce cross-linking between molecules, degradation by random fracture of the main chain and destruction of crystallinity. Changes in mechanical properties were determined by a dynamic method measuring Young's modulus and damping in polystyrene, polymethylmethacrylate, and polyethylene. Minimum values in density and elastic modulus, and maximum values in damping at room temperature, are observed for a critical radiation dose.

154. Barducci, I.,
DIFFUSION COEFFICIENT OF N IN ALPHA-Fe, Nuovo Cimento, Vol. 3, 1956, pp. 350-358 (In English).

Measurements on internal friction in solid solutions of nitrogen in alpha-iron over the range 300 to 500° K confirm values of $D_0 = 3 \times 10^{-3}$ square centimeters per second and $\Delta H = 18,200$ calories per mole reported by Wert. Differences between experimental and calculated values are believed within experimental error.

155. Barducci, I. and Gence, P.,
EXPERIMENTAL DETERMINATION OF THE HEAT OF ACTIVATION FOR DIFFUSION OF N IN α -Fe, Ricerca Scientifica, 26, 1956, pp. 2080-2084.

A new measurement has been carried out by a dynamic method utilizing the elastic relaxation phenomenon due to diffusion. The value determined (18,200 calories per mole ± 300) is the same as that found by Wert and in good agreement with the value obtained by H. Hendus and H. Rohrig.

156. Barducci, I. and Verdini, L.,
EXPERIMENTAL STUDY OF INTERNAL FRICTION AND ELASTIC PARAMETERS IN Ag-Au ALLOYS, Nuovo Cimento, Supplement to Vol. 4, Series X, No. 2, 1956, pp. 1042-1056.

A silver-gold alloy was chosen for study because of its simple phase diagram and the complete compatibility of the

two metals at all temperatures and in any proportions. The article describes the preparation of specimens, the measuring methods, and the results.

157. Bartenev, G. M., Reznikovskii, M. M., and Khromov, M. K., INVESTIGATION OF THE DYNAMIC PROPERTIES OF VULCANIZED RUBBERS BY THE SPONTANEOUS CONTRACTION METHOD, Kolloidnyi Zhurnal, Vol. 18, 1956, pp. 395-403.

A correlation has been established between the modulus of internal friction and the vitrification temperature of unfilled vulcanizates of natural and butadiene (SKB, SKN-18, 26, 40) rubbers. It was shown that the ratio of the internal friction modulus of the rubber to the unequilibrated part of its dynamic modulus depends little upon the test temperature, the type of polymer, the degree of vulcanization, or the filler and the plasticizer contents.

158. Becker, G. W. and Oberst, H., ON THE DYNAMIC-ELASTIC BEHAVIOR OF LINEAR CROSS-LINKED AND FILLED MATERIALS, Kolloid-Zeitschrift, Vol. 148, Nos. 1 and 2, 1956, pp. 6-16 (In German).

The authors arrange plastics into linear, cross-linked and filled classes. Loss coefficient, η , is given as a function of frequency for a number of materials.

159. Belov, K. P., THERMODYNAMIC THEORY OF MAGNETO-ELASTIC AND MAGNETOSTRICTION PHENOMENA IN FERROMAGNETICS, Akademii Nauk S. S. S. R., Fizika Metallov i Metallovedenie, Vols. 2 and 4, 1956, pp. 47-53.

The alloys studied were: (30 percent nickel-70 percent iron), (32 percent nickel-68 percent iron), (33 percent nickel-67 percent iron), (36 percent nickel-64 percent iron), all with Curie points at low temperatures where the magnetic transformation is very sluggish. With Belov's thermodynamic formula modified by the addition of a term containing the elastic coefficient, it is possible to determine the effect of elastic phenomena on spontaneous magnetization and magnetostriction near the Curie point.

160. Benbow, J. J.,
THE DETERMINATION OF DYNAMIC MODULI AND INTERNAL FRICTION OF HIGH POLYMERS FROM CREEP MEASUREMENTS, Physical Society Proceedings, B, Vol. 69, Part 9, September 1956, pp. 885-892.

An account is given of the use of Fourier analysis to transform creep measurements to dynamic quantities with specific reference to some measurements made on polythene. The method is based on a technique described by Roesler, but additional theory is given which eliminates the necessity of determining the retardation spectrum explicitly. Using the derived dynamic quantities as a standard, it is shown that more approximate methods provide sufficiently accurate transformations for many practical purposes if the retardation spectrum of the material is very flat.

161. Birger, I. A.,
NEKOTORYE MATEMATICHESKIYE METODY RESHENIYA INZHENERNYKH ZADACH ("Some Mathematical Methods for the Solution of Engineering Problems"), Moscow, Oborongiz, 1956 (In Russian).

Mathematical treatment of several important questions in engineering leads to solving boundary-value problems for ordinary differential equations. A. N. Krylov has pointed to the role of normal fundamental functions for such significant technical cases as the action of concentrated loads and moments where the desired solution or its derivatives must have certain discontinuities. If the problem reduces to differential equations with variable coefficients, then it is often useful to apply the efficient methods of integral equations. The first two chapters of the book explain the theory and use of normal functions in the case of ordinary differential equations, both with constant and variable coefficients. The remaining two chapters are devoted to integral equations and their applications in engineering. Author illustrates general methods of various problems of elasticity and theoretical mechanics (vibrations, stability, etc.).

162. Birnbaum, H. and Levy, M.,
INTERNAL FRICTION OF ALUMINUM SINGLE CRYSTALS
AS A FUNCTION OF TEMPERATURE, Acta Metallurgica,
Vol. 4, No. 1, 1956, pp. 84-88.

Deformation and rapid cooling to 77° K resulted in a relaxation peak at about 100° K. Between 350° and 450° K as-grown crystals exhibited discontinuous increases and decreases of decrement with temperature. An exponential dependence of decrement on temperature was observed from 450° to 650° K.

163. Bishop, R. E. D.,
THE BEHAVIOR OF DAMPED LINEAR SYSTEMS IN STEADY
OSCILLATION, Aeronautical Quarterly, Vol. 7, No. 3,
May 1956, pp. 156-168.

The classical theory of small harmonic vibrations of a linear damped system embodies the notion of "viscous damping." The equations of motion which result are somewhat complicated and, when there are more than two degrees of freedom, they are usually too unwieldy to be of much practical value. When the damping is small, however, approximating assumptions may be made which permit the treatment of systems which are near resonance as if they possess but one degree of freedom. Nevertheless, the effects of making these assumptions are by no means easily assessed, and even their justification is tedious. It is shown that these difficulties may be greatly diminished by postulating hysteretic damping instead of viscous damping; the concept of hysteretic damping has been dealt with in two previous papers. The equations then take a much simpler form and the justification for, and validity of, the foregoing approximations are more easily seen. Moreover, the effects of damping upon the principal modes which the system possesses in the absence of this damping may be elucidated in this way.

164. Bishop, R. E. D.,
THE GENERAL THEORY OF "HYSTERETIC DAMPING",
Aeronautical Quarterly, Vol. 7, No. 2, February 1956,
pp. 60-70.

This paper is the second of a series of three. The first dealt with the steady forced harmonic motion of a simple oscillator with one degree of freedom when "hysteretic damping" is present. The present paper is devoted to the

formulation of a general theory of small hysteretically damped vibration in which the existence is postulated of damping forces which act between pairs of points such that they are in phase with the relative velocities and their magnitudes are proportional to relative displacements. The theory is presented in general terms, and use is made of Lagrange's equation with a new type of "dissipation function;" this is comparable with that of Rayleigh for viscous damping. It is shown that this theory generally leads to simpler algebra than does that of viscous damping. Moreover, it will be thought of in terms of modes more simply than is the case with the more familiar viscous damping.

165. Bömmel, H. E., Mason, W. P., and Warner, A. W., DISLOCATIONS, RELAXATIONS, AND ANELASTICITY OF CRYSTAL QUARTZ, Physical Review, Vol. 102, 1956, pp. 64-71; Institute of Radio Engineers, Proceeding, Vol. 40, 1952, pp. 1030-1033.

With careful grinding and etching, contouring, and mounting in a vacuum, very small internal friction coefficients, Q^{-1} , are found in AT shear vibrating crystals. The internal friction corresponds to that of the quartz itself. The internal friction at room temperature increases with frequency up to 100 mc/sec; this indicates the presence of relaxations. The internal friction was measured at temperatures to 1.5° K. Two relaxations were found. One is connected with a distorted lattice due to impurities. One is due to dislocation loops. A long-time aging effect is due to closer pinning of dislocations by impurity atoms. An improved frequency standard, free from aging effects, can be obtained by maintaining the crystal at liquid-helium temperatures.

166. Boulanger, C. and Crussard, C., MECHANICAL HYSTERESIS OF METALS AT HIGH TEMPERATURES, Métaux. Corrosion-Industries, Vol. 31, May 1956, pp. 203-213.

The application of dislocation theories to explain the properties of metals at elevated temperatures is discussed. The measurement of the oscillation of metal samples under torsion at temperatures up to 1600° C is described, and results obtained are considered. Mechanical hysteresis and internal friction are of great importance in determining the

properties of metals at high temperatures. The creep of metals is caused by movement of dislocations, and the diffusion of dislocations is discussed.

167. Boulanger, C. and Crussard, C.,
STUDY OF MECHANICAL PROPERTIES AT VERY HIGH TEMPERATURES, Revue de Métallurgie, Vol. 53, No. 9, 1956, pp. 715-728.

Measurements were made on aluminum, copper, and iron. For iron, tests were made up to 1500° C. Data were strongly affected by the phase transformation.

168. Bratina, W. J. and Winegard, W. C.,
INTERNAL FRICTION IN ZIRCONIUM, Journal of Metals, Vol. 8; American Institute of Mining, Metallurgical and Petroleum Engineers (AIME) Transactions, Vol. 206, 1956, pp. 186-189.

Internal friction characteristics and temperature dependence of the torsion modulus for iodide zirconium containing 2.4 percent hafnium were investigated by using a low-frequency pendulum technique. The internal friction curve consists of a background which increases as the temperature increases, a maximum at 860° apparently due to the allotropic transformation, a maximum due to grain boundary relaxation with an associated heat of activation of 58,000 calories/mole, and an anomaly below 350° which can be associated with a precipitation phenomenon. Oxygen in small amounts reduces the grain boundary maximum substantially.

169. Bungardt, K. and Preisendanz, H.,
DAMPING INVESTIGATIONS OF IRON-CHROMIUM ALLOYS, Archiv für das Eisenhüttenwesen, Vol. 27, November 1956, pp. 715-724.

Damping measurements have been made in a vacuum apparatus on iron-chromium alloys up to 45 percent chromium. Three separate damping maxima were found at 220°, 600°, and 720° C. Nitrogen and carbon were found to have a decisive effect on their formation.

170. Busby, P. E., Hart, D. P., and Wells, C.,
DIFFUSION OF NITROGEN IN IRON, Journal of Metals,
Vol. 8; American Institute of Mining, Metallurgical and
Petroleum Engineers (AIME) Transactions, Vol. 206,
1956, pp. 686-687.

The diffusion of nitrogen in alpha-iron was studied by means of the fractional saturation method. Resulting diffusion coefficients are in excellent agreement with the values obtained from internal friction experiments.

171. Cabarat, R.,
NEW DYNAMIC METHOD FOR MEASUREMENT OF THE
ELASTIC MODULUS AND THE CAPACITY FOR DAMPING,
Acustica, No. 1, 1956, pp. 200-204 (In French).

A dynamic method is described for the determination of elastic modulus and damping. This method is effective to a temperature of 800° C. Excitation is made electrostatically. Nonconducting materials are given a conducting surface, and the logarithmic decrement is calculated from the resonance and decay curves. The sensitivity of the method is shown from some examples of measurements. The construction of an elasticity meter is given.

172. Chang, T. S. and Kesler, C. E.,
CORRELATION OF SONIC PROPERTIES OF CONCRETE
WITH CREEP AND RELAXATION, American Society for
Testing Materials (ASTM) Proceedings, Vol. 56, 1956,
pp. 1257-1272.

This paper presents a method of relating the properties of concrete that can be obtained from sonic testing to the creep behavior in compression and flexure and relaxation behavior in compression. Valid nonlinear mechanical models are selected to represent concrete in creep and relaxation, and their coefficients are statistically related to the sonic properties. A simple procedure is also developed to relate the creep of one concrete beam to another under different loading.

The results presented provide a means of predicting creep and relaxation behavior of concrete from a relatively simple sonic test.

173. Chatterjee, G. P.,
VIBRATION DAMPING CHARACTERISTICS AND ANELASTIC BEHAVIOR OF LOW CARBON STEEL, Second Congress of Theoretical and Applied Mechanics, Proceedings, New Delhi, India, Kharagpur, India, Indian Society of Theoretical and Applied Mechanics, Indian Institute of Technology, 1956, pp. 16-23.

This paper presents results of measurements of hysteresis in slow (100 psi per minute) tensile loading up to low (100 psi) maximum stress and measurements of specific damping capacity in torsion of 0.14 percent steel. Author concludes there is measurable anelasticity even at low stress levels and that damping capacity is extremely structure sensitive.

174. Cochardt, A. W.,
HIGH-DAMPING FERROMAGNETIC ALLOYS, Journal of Metals, Vol. 8; American Institute of Mining, Metallurgical and Petroleum Engineers (AIME) Transactions, Vol. 206, 1956, pp. 1295-1298.

Wires of 55 binary and ternary cobalt, iron nickel, and chromium twisted, and the decay of the free torsion vibration was measured at torsion stresses between 500 and 8000 pounds per square inch. Especially high damping was observed on the following alloys: Co-28% Fe-7% Ni and Co-20% Fe, and Co-35% Ni. This effect is explained in terms of magnetomechanical hysteresis.

175. Cochardt, A. W.,
PREDESIGNED ALLOY LEADS TO NEW METALS CONCEPT, Industrial Laboratories, August 1956, pp. 96-98.

Discussion of magnetomechanical damping and the development of suitable alloys for high temperature turbine applications.

176. Cook, R. K. and Wasilik, J. H.,
ANELASTICITY AND DIELECTRIC LOSS OF QUARTZ, Journal of Applied Physics, Vol. 27, 1956, pp. 836-837.

Anelastic effects in quartz are ascribed to the motion of metallic interstitial ions in the "tunnels" of the quartz lattice.

177. Cunningham, J. R. and Ivey, D. G.,
DYNAMIC PROPERTIES OF VARIOUS RUBBERS AT HIGH
FREQUENCIES, Journal of Applied Physics, Vol. 27, 1956,
pp. 967-974.

The shear wave velocity and attenuation of GR-S, Butyl, Hevea, Hycar, and Paracril rubbers have been measured in the frequency range of 0.2 to 7 mc/sec and the temperature range of -60° to 20° .

178. Deeg, E.,
ELASTOPLASTIC BEHAVIOR OF HARD PORCELAIN,
INVESTIGATED IN THE MOIST STATE UP TO THE FIRED,
FINISHED PRODUCT, Silicates Industriels, Vol. 21, 1956,
pp. 265-270.

By ultrasonic measurements of Young's modulus, E , the complex modulus and the internal viscosity (damping), η , in ceramic bodies either in the green state or fired at variable temperatures, the structural changes are qualitatively determined. The piezocrystal controlled oscillation device is discussed in its operation, the results are compared with those of standard metals (steel, lead, tungsten).

179. Deeg, E.,
INVESTIGATION OF THE ELASTIC-PLASTIC BEHAVIOR
OF A HARD PORCELAIN BODY FROM THE WET PLASTIC
TO THE FULLY FIRED STATE, Ber. deut. keram. Ges.,
Vol. 33, 1956, pp. 1-7.

The theory of the determination of modulus of elasticity and of internal friction is described, and some details are given of an apparatus for the sonic resonance method of measurement at temperatures up to 750° C. The curves relating the change of room temperature elasticity (generally an increase) and internal friction (generally a decrease) with increase of the temperature of pretreatment show marked peaks, troughs, and inflections associated with the change in moisture content, removal of the adsorbed moisture, decomposition of the kaolinite lattice, quartz inversion, decomposition of the metakaolin lattice, formation of γ - Al_2O_3 or mullite, secondary mullite formation, and the initial melting of the feldspar.

180. de Meij, S. and Van Amerongen, G. J.,
DYNAMIC-MECHANICAL CHARACTERISTICS OF RUBBER
COMPOUNDS, Kautschuk und Gummi, Vol. 9, 1956,
pp. WT56-62.

An electrodynamic forced vibration apparatus is described for measuring dynamic properties in both shear and compression. The frequency range is 5 to 200 cps and the temperature range, -40° to 100° . The temperature, frequency, and amplitude dependence of the dynamic properties were studied for a variety of compounds. The maximum in the loss factor near the second-order transition point occurred at a lower temperature for natural rubber than for cold rubber, Vulcollan, and Butyl rubber. A compound containing a styrene-butadiene resin showed two maxima, one at 80° . This did not occur for aniline resin reinforcement. The dynamic properties of Butyl rubber containing 50 parts EPC black and prepared with and without heat-treatment were compared. SAF and EPC blacks in natural rubber gave higher dynamic moduli at low amplitudes than did HAF black. Reinforcement with Aerosil and with aniline resin showed low values for the loss factors. Thiuram vulcanizates had high losses.

181. Dieckamp, H. and Sosin, A.,
EFFECT OF ELECTRON IRRADIATION ON YOUNG'S
MODULUS, Journal of Applied Physics, Vol. 27, 1956,
pp. 1416-1418.

Young's modulus and internal friction measurements are reported on high-purity copper following electron bombardment. The modulus is observed to rise rapidly with electron flux, reaching an early saturation followed by a slow decrease. The rapid saturation is attributed to dislocation pinning. The rate of saturation is temperature dependent in the range from -195° to about zero; this suggests defect migration at low temperatures. The slow decrease is attributed to a "bulk effect" owing to interstitial-vacancy pairs.

182. Ecker, R.,
SECONDARY TRANSITION REGIONS WITH COPOLYMERS,
POLYMER MIXTURES, AND GRAFT POLYMERS, Kautschuk
und Gummi, Vol. 9, 1956, pp. WT153-159.

For any type of polymer and deformation, the curves of stiffness and of damping versus temperature have characteristic shapes through the transition region from normal elastic to high elastic and plastic behavior.

183. Eirich, F. R., (Editor),
RHEOLOGY. THEORY AND APPLICATIONS, New York,
New York, Academic Press, 1956, 761 pp.

Topics covered include various phases of the deformation of solids, flow under high pressures, mechanism of liquid flow, large elastic deformations, viscoelasticity, melt flow, rheology of disperse systems, and acoustic responses of liquids.

184. Etkin, L. G.,
A METHOD OF DETERMINING THE DISSIPATION OF
VIBRATIONAL ENERGY BY THE JOINTS AND PARTS OF
MACHINERY, Zavodskaya Laboratoriya, Vol. 22, 1956,
pp. 1450-1482 (In Russian).

This paper describes a method to determine the damping of a flanged steel tube under torsional stress. In the experiments, torsional moments, vibrational amplitude, and the phase shift between the moments are measured. Damping is expressed in terms of quality factor, Q .

185. Fast, J. D.,
THE EFFECT OF IMPURITIES ON THE PROPERTIES OF
PURE IRON, Stahl und Eisen, Vol. 73, 1956, pp. 1484-1496;
Metallurgia, September 1956, pp. 123-127.

In an attempt to assess the effect of small amounts of impurities on the properties of iron and steel, an investigation has been made using very high purity iron, with and without the addition of known amounts of various impurities, particularly carbon and nitrogen.

186. Fast, J. D.,
MOLECULAR INTERPRETATION OF RELAXATION
PHENOMENA, Chemisch Weekblad, Vol. 52, 1956, pp. 445-
460.

The general theory of relaxation phenomena is reviewed. The Snoek effect in alpha-iron dielectric relaxation, paramagnetic relaxation, and internal friction of metals are discussed in more detail.

187. Federhofer, K.,
INFLUENCE OF INTERNAL DAMPING AND OF EXTERIOR
FLUID FRICTION ON THE PLANE BENDING VIBRATION
OF A CIRCULAR RING, Ost. Ing. -Arch., Vol. 10, 1956,
pp. 344-349 (In German).

This paper extends the results of the author's earlier work on circular rings by taking account of internal and external friction. It is shown that with internal viscous friction, the coefficient of damping increases with increasing mode number.

188. Federighi, T. and Gatto, F.,
ELASTIC-MODULUS AND INTERNAL-FRICTION MEASURE-
MENTS AS METHODS FOR INVESTIGATION OF THE KINET-
ICS OF THE RECRYSTALLIZATION OF ALUMINUM,
Alluminio, Nuova Metallurgia, Vol. 25, 1956, pp. 279-285.

The isothermal recrystallization process of aluminum was examined by the dynamically measured elastic modulus and the internal friction. The conditions and limits of use of these methods are specified.

189. Federighi, T.,
INTERNAL FRICTION: A NEW PHYSICAL QUANTITY FOR
THE STUDY OF METALS, Alluminio, Nuova Metallurgia,
Vol. 25, No. 5, May 1956, pp. 225-230.

Essential characteristics of internal friction are illustrated with an explanation of the physical significance as well as the methods of measurement.

190. Ferro, A. and Montalenti, G.,
MECHANICAL AND MAGNETIC RELAXATION OF ALPHA-
IRON, Metallurgia Italiana, Vol. 48, 1956, pp. 124-128.

The heat of activation and relaxation time of carbon in solid solution were measured on iron specimens. The data agree with those of the literature for pure iron. Neither Q nor T_0 depend on free carbon content or magnetic field applied. For small carbon content, magnetic relaxation appears to be proportional to carbon content.

191. Fukutomi, T.,
THE INTERNAL FRICTION AND THE GRAIN SIZE OF
TUNGSTEN FILAMENTS, Oyo Butsuri, Vol. 25, 1956,
pp. 381-384.

The internal friction of tungsten filaments is measured between the room temperature and 2900° K with an apparatus which is illustrated. Below 1000° K, all values of friction nearly coincide with each other to a very small value. Above 1000° K, it is structure-sensitive. The value for a filament composed of both long and small grains falls in between. Grain growth by heat treatments decreases $1/Q$. The internal friction of the filaments at high temperature mainly originates in the movement of grain boundaries and is sensitive to the area of the boundaries or the size of grains.

192. Galaka, P. I.,
EXPERIMENTAL INVESTIGATION OF AN IMPULSE
VIBRATION DAMPER WHEN FREE VIBRATIONS ARE
OPERATING, Dopovidi Akademiya Nauk SSSR, No. 3,
1956, pp. 238-240 (In Russian).

It is shown that the action of the vibration extinguisher emerges as a clear-cut damping of vibrations, during which the damping increases with an increase in the masses of the intercolliding bodies and the clearance between them.

193. Gates, G. H. and Larson, W. M.,
POLYURETHANE RUBBER AS A MATERIAL OF CON-
STRUCTION, Mechanical Engineering, Vol. 78, 1956,
pp. 1016-1018.

Quantitative data are given in charts and tables for hardness, stress capacity, hysteresis, abrasion, resilience,

and damping properties of polyurethane and natural and other synthetic rubbers. Polyurethane has a much higher stress capacity than natural rubber and a high hysteresis loss. Applications considered include industrial solid tires, high-pressure pump valve inserts, motor mounts, sponges, and foam.

194. Gebhardt, E. and Preisendanz, H.,
THE SOLUBILITY OF OXYGEN IN TANTALUM AND ITS
EFFECT ON THE PROPERTIES, Plansee Proc., 1956,
pp. 254-267.

The equilibrium between tantalum and O₂ is not reversible. Below 1500°, pressure decrease does not lead to a liberation of O₂. A temperature increase to above 2300° and a simultaneous pressure decrease to below 10⁻⁵ millimeters are required for the complete elimination of dissolved oxygen. The existence of a true solution is proved by damping measurements. The damping versus temperature curves show for oxygen-containing specimens a pronounced maximum at 170°, the height of the maximum increasing with the oxygen content.

195. George, F. W.,
ELECTROMECHANICAL FILTERS FOR 100 KC/S CARRIER
AND SIDEBAND SELECTION, Institute of Radio Engineers,
Proceedings, Vol. 44, January 1956, pp. 14-18.

Spurious modes of vibration are reduced by a balanced arrangement of the transducers and by mechanical damping in the end supports.

196. Goldman, D. E. and Hueter, T. F.,
TABULAR DATA OF THE VELOCITY AND ABSORPTION
OF HIGH FREQUENCY SOUND IN MAMMALIAN TISSUES,
Acoustical Society of America, Journal, Vol. 28, No. 1,
January 1956, pp. 35-37.

This report is a condensed presentation of currently available data.

197. Gontkevich, V. S.,
THE INFLUENCE OF CERTAIN FACTORS ON THE DAMPING PROPERTIES OF THE PRINCIPAL MATERIALS USED IN TURBINE CONSTRUCTION IN THE PRESENCE OF BENDING VIBRATIONS, Sb Trudi Labor. Gidrav. Mashin, Akademiya Nauk, SSSR, No. 6, 1956, pp. 192-202(In Russian).

This paper discusses the problem of the influence of heat treatment, work hardening (in plastic bending) and increasing the temperature to 600° C on the dissipation of energy in the principal steel grades used in turbine construction. Data obtained by the author are presented on the change in the relative dynamic modulus of elasticity with temperature for these materials.

198. Gontkevich, V. S. and Butkovskii, V. V.,
DETERMINATION OF THE LOSS OF ENERGY DUE TO INTERNAL FRICTION IN THE METAL DURING DEFLECTION VIBRATIONS, Sb. Trudi Labor. Problem Bystrokhod. Mashin i Mekhanizmov Akademiya Nauk SSSR, No. 5, 1956, pp. 169-178 (In Russian).

Some results are given of the experimental determination of the energy dissipated by ten different steels during decaying vibrations. Use was made of tuning fork samples with resistance gages glued to the foot of the tuning fork to obtain amplitude of vibrations.

199. Goodman, L. E. and Klumpp, J. H.,
ANALYSIS OF SLIP DAMPING WITH REFERENCE TO TURBINE-BLADE VIBRATION, Journal of Applied Mechanics, Vol. 23, 1956, pp. 421-429 (Wright Air Development Center, Wright-Patterson Air Force Base, Ohio, 1955, Report No. TN 55-232).

Energy of vibration may be dissipated by microscopic slip on interfaces where machine elements are joined in a press fit. In this paper, slip damping is studied as an agent in reducing turbine-blade resonant stresses and prolonging turbine life. A general theory of slip damping is developed, and an expression for the energy loss per cycle of oscillation is found.

200. Gordon, R. B. and Nowick, A. S.,
THE PINNING OF DISLOCATIONS BY X-IRRADIATION OF
ALKALI HALIDE CRYSTALS, Acta Metallurgica, Vol. 4,
September 1956, p. 514.

A study was made of the effect of X-irradiation on the room temperature elastic modulus of sodium chloride crystals. A theory is developed which assumes that vacancies, released within the volume of the crystal through the action of the radiation, migrate to dislocations and contribute to the formation of pinning points. The theory makes possible a calculation of the density of dislocations and the mean length of the free dislocation loops prior to irradiation.

201. Granato, A. and Lücke, K.,
THEORY OF MECHANICAL DAMPING DUE TO DISLOCATIONS, Journal of Applied Physics, Vol. 27, No. 6, June 1956, pp. 583-593.

This article develops a quantitative theory of damping and modulus changes due to dislocations. It is found that the model used by Koehler of a pinned dislocation loop oscillating under the influence of an applied stress leads to two kinds of loss, only one of which is dependent on frequency. The frequency dependent loss has its maximum in the high megacycle range. The second type of loss is a hysteresis loss independent of frequency over a wide frequency range including the kilocycle range. This loss has a strain-amplitude dependence of the type observed in the kilocycle range. The theory provides a quantitative interpretation of the loss.

202. Granato, A. and Lücke, K.,
APPLICATION OF DISLOCATION THEORY TO INTERNAL FRICTION PHENOMENA AT HIGH FREQUENCIES, Journal of Applied Physics, Vol. 27, July 1956, pp. 789-805.

This article presents a detailed discussion of data obtained over the past 15 years concerning the damping of mechanical vibrations in the kilocycle and megacycle range. The dependence of the decrement and modulus change on the variables of frequency and strain-amplitude and many other parameters are compared with the predictions of an earlier dislocation theory.

203. Granato, A. and Truell, R.,
FREQUENCY DEPENDENCE OF ULTRASONIC ATTENUATIONS IN GERMANIUM, Journal of Applied Physics, Vol. 27, October 1956, pp. 1219-1266.

Measurements of the attenuation of compressional waves traveling in the [100] direction in germanium, taken in the frequency range 5 to 300 megacycles, are reported. The attenuation is attributed to the damped forced oscillation of dislocation segments.

204. Grin, A. V. and Pavlov, V. A.,
INTERNAL FRICTION IN DEFORMED ALLOYS OF ALPHA SOLID SOLUTION OF ALUMINUM WITH MAGNESIUM, Akademii Nauk, SSSR, Fizika Metallov i Metallovedenie, Vol. 3, 1956, pp. 179-180.

Wires of 0.01 to 1.0 magnesium alloy were tested for their damping characteristics at 20° to 500°. Pure aluminum has one maximum for internal friction, but 0.05 percent magnesium alloy has two of them, the second being connected with magnesium diffusion in the deformed alloy and absent in it after annealing.

205. Grobner, W.,
CONSIDERATION OF FRICTION IN VIBRATION PROBLEMS, Ost. Ing.-Arch., Vol. 10, 1956, pp. 171-175 (In German).

The author presents an energy method which uses a variational principle. A theory is developed using expressions for kinetic and potential energy and applying Hamilton's principle and LaGrange's function. The frictional effects are treated in the variational integral as a constant multiplied by a velocity to the n th power, where n is a real number. While this method is not limited to linear damping, it is applied to vibrating springs and vibrating membranes, with $n = 1$ for both cases.

206. Grubin, C.,
ON THE THEORY OF THE ACCELERATION DAMPER, Journal of Applied Mechanics, Vol. 23, No. 3, September 1956, pp. 373-378.

The acceleration damper reduces the vibration of a mechanical system through momentum transfer by collision

and conversion of mechanical energy into heat. A typical unit consists of a mass particle moving in a container fixed to the primary vibrating system. The direct problem is to determine the motion of a single-degree-of-freedom system with a damper, when the driving force is a simple harmonic. The inverse is to determine the characteristics of a damper for reducing the vibration of the same system to a prescribed value. Numerical results indicate that the damper is most effective at resonance.

207. Guillet, L and Hocheid, B.,
STUDY OF THE DIFFUSION OF CARBON AND NITROGEN
IN ALPHA-IRON BY MEASUREMENT OF THE INTERNAL
FRICTION, Revue de Métallurgie, Vol. 53, 1956, pp. 122-
130.

Internal friction measurements at various vibration frequencies independent of the temperature are used for the determination of the heat of activation during the diffusion of carbon and nitrogen in alpha-iron. The heat of activation for carbon and nitrogen were found to be 20,100 calories per mole and 18,600 calories per mole, respectively.

208. Gur'ev, A. V.,
ORIGIN OF ELASTIC IMPERFECTIONS IN A POLYCRYSTAL-
LINE ALLOY, Akademii Nauk SSSR, Fizika Metallov
i Metallovedenie, Vol. 3, 1956, pp. 349-359.

By using a new tensometer, accurate to 0.1μ (as described), elastic elongation and transverse contraction of several carbon steels and of modified iron were determined and curves of elastic hysteresis plotted. Loops of elastic hysteresis can be measured both by the axial and transverse deformations, though in the first case their widths are twice as large. Because this value corresponds to the coefficient of transverse plastic deformation without any volume change, this may serve as a proof that the reason for the formation of closed hysteresis loops lies in the occurrence of local plastic slips along the portion of specimen cross section (microvolumes).

209. Hamme, R. N.,
HOW TO USE ACOUSTICAL MATERIALS, Machine Design,
Vol. 28, 26 July 1956, pp. 68-74.

A review of the engineering factors involved in selecting materials for the four important methods of noise control: sound-transmission attenuation, sound absorption, vibration isolation, and vibration damping.

210. Hanson, M. P.,
A VIBRATION DAMPER FOR AXIAL-FLOW COMPRESSOR
BLADING, Society for Experimental Stress Analysis,
Proceedings, Vol. 14, No. 1, 1956, pp. 155-162.

This paper presents a method of vibration suppression in axial-flow compressor blading and involving centrifugally loaded pins that contact the blade and rotor. During vibration, the relative motions between the contacting surfaces introduce frictional forces and thereby establish damping in the blade system. The desired high damping is obtained by a suitable selection of pin material, mechanical fit, and blade proportions. The results of the investigation indicate that with the use of a pin damper, the vibratory stress of the test blade was reduced by a factor of ten. The damper remained effective after a total of 100 hours of operation regardless of severe frictional wear of the pin. Variation of the centrifugal loading had only a small effect on the resulting high damping.

211. Hasiguti, R. R., Kamoshita, G., and Igata, N.,
INTERNAL FRICTION OF POLYCRYSTALLINE IRON DUE
TO POINT DEFECTS, Metal Physics, Vol. 2, 1956, pp. 163-
164.

Not abstracted.

212. Hatfield, P.,
ULTRASONIC MEASUREMENTS IN HIGH POLYMERS,
Research, Vol. 9, 1956, pp. 388-395.

The pulse, optical diffraction, and continuous wave methods for measuring the velocity and absorption of longitudinal and transverse ultrasonic waves in high polymers are described. The experimental results for natural and synthetic rubbers, polyethylene, and polyvinyl chloride are discussed.

213. Hatfield, P.,
ULTRASONIC MEASUREMENTS ON HIGH POLYMERS,
Journal of Applied Physics, Vol. 27, No. 2, February 1956,
pp. 192-193.

The velocity and absorption of longitudinal waves in high polymers were measured over the temperature range -10° to 60° C and over the frequency range 50 to 1000 kc/sec, using a continuous-wave method. The amplitude of the absorption peaks showed an approximate linear increase with frequency.

214. Heijboer, J.,
MOLECULAR SIGNIFICANCE OF SECONDARY DAMPING
MAXIMA, Kolloid-Zeitschrift, Vol. 148, 1956, pp. 36-47.

The variation of mechanical damping with frequency is studied in the hard glassy region for methacrylate polymers. The primary maxima are related to the transition of the polymer to the rubbery state. The secondary maxima are related to the rotation of the methoxycarbonyl side group, but only appear if this rotation is hindered by adjoining methyl groups attached to the main chain.

215. Hendrickson, J. A., Wood, D. S., and Clark, D. S.,
THE INFLUENCE OF TEMPERATURE ON PRE-YIELD
PLASTIC AND ANELASTIC MICROSTRAIN IN LOW CARBON
STEEL, Acta Metallurgica, Vol. 4, No. 6, November 1956,
pp. 593-601.

Rates of pre-yield microstrain when stress is first applied are compared with the theoretical rates for the thermally activated release of dislocations from atmospheres of interstitial solute atoms.

216. Hikata, A., Truell, R., Granato, A., Chick, B., and
Lucke, K.,
SENSITIVITY OF ULTRASONIC ATTENUATION AND
VELOCITY CHANGES TO PLASTIC DEFORMATION AND
RECOVERY IN ALUMINUM, Journal of Applied Physics,
Vol. 27, April 1956, pp. 396-404.

Measurements of changes in ultrasonic attenuation together with changes in ultrasonic velocity were made concurrently with load strain measurements in tensile tests on the same specimen.

217. Hilbert, K.,
TEMPERATURE DEPENDENCE OF THE INTERNAL
FRICTION AND OF THE MODULUS OF ELASTICITY OF
GLASSES, Silikattechnik, Vol. 10, 1956, pp. 394-399.

By measuring the flexural vibrations of glass rods a pronounced internal friction maximum was found in the temperature range below the transformation point. This is believed to be caused by the migration of the silica tetrahedra in the glass network under the influence of changing temperature.

218. Holder, S. G., Jr., Stansbury, E. E., and Frye, J. H., Jr.,
INTERNAL FRICTION STUDIES ON SILVER AND CERTAIN
SILVER-BASE SOLID SOLUTIONS, Journal of Metals,
Vol. 8; American Institute of Mining, Metallurgical and
Petroleum Engineers (AIME) Transactions, Vol. 206, 1956,
pp. 993-997.

Internal friction studies on annealed and cold-worked pure silver and alloys of silver with 4.5 percent each of cadmium, tin, and antimony are reported. Small amounts of cold work, introduced by stretching pure silver, decrease the internal friction; large amounts of cold work, by wire drawing, cause this decreased internal friction to rise.

219. Hueter, T. F.,
SONIC TECHNIQUES FOR INDUSTRY, Science, Vol. 124,
No. 26, October 1956, pp. 787-792.

General review of the use of sonic and ultrasonic techniques in industry.

220. Hughes, D. S. and Maurette, C.,
DYNAMIC ELASTIC MODULI OF IRON, ALUMINUM, AND
FUSED QUARTZ, Journal of Applied Physics, Vol. 27,
1956, pp. 1184-1186.

The dynamic elastic constants of Armco iron, pure aluminum, and fused quartz have been measured with a supersonic pulse technique as functions of pressure and temperature over the range of 1 to 900 bars and 25° to 300° C (200° C for quartz). Within the experimental accuracy the dynamic elastic moduli of these materials can be represented by linear functions of pressure and temperature.

221. Hunter, H. F.,
THE STRUCTURAL DAMPING OF TITANIUM AT ELEVATED
TEMPERATURES, Aero. Eng. Rev., Vol. 15, 1956, pp. 18-
21.

The structural damping of titanium at elevated temperatures was tested with heated tuning forks by measuring the rate of vibration decay. In the range of parameters tested, the damping alloys increased with stress and decreased with frequency.

222. Hutchison, T. S. and Filmer, A. J.,
ATTENUATION OF 5 Mc. SOUND IN ALUMINUM AT LOW
TEMPERATURES, Canadian Journal of Physics, Vol. 34 (2),
1956, pp. 159-165.

The attenuation of sound at a frequency of five megacycles has been found to reach a maximum in aluminum at 155° K. Combination of this result with the work of Bordoni, who obtained a maximum at 40 kilocycles and 100° K, gives an activation energy in agreement with the value calculated by Mason for a dislocation relaxation process.

223. Hutchison, T. S. and Hutton, G. J.,
MECHANISM OF DISLOCATION LOCKING IN ATTENUATION
OF HIGH FREQUENCY SOUND AT LOW TEMPERATURES,
Canadian Journal of Physics, Vol. 34, No. 12B, December
1956, pp. 1498-1500.

The internal friction peak at 155° K in pure aluminum, using 5 mc/sec sound waves, and enhanced by cold working, was investigated after different periods of room temperature aging. It is shown that the loop-length locking point is much too small to account for the observed peak on the basis of a dislocation relaxation mechanism.

224. Huzimura T. and Sutoki, T.,
ELASTIC AFTER-EFFECT, Tohoku University, Science
Reports of the Research Institutes, Ser. A, Vol. 8, No. 2,
April 1956, pp. 79-86.

Phenomenon was studied with metal wires at various temperatures, and the results were explained by the theory of recovery based on the dislocation model.

225. Imoto, S. and Mima, G.,
INTERNAL FRICTION DUE TO WATER IN COPPER, Osaka University, Technology Reports, Vol. 6, March 1956, pp. 141-144.

A copper polycrystalline specimen which contained 0.2 percent oxygen was heated in a hydrogen atmosphere until it no longer absorbed hydrogen. The internal friction was measured on this specimen under gradually increasing temperature from -10° C. Then a peak appeared on the internal friction versus temperature curve near 0° C.

226. Inoue, Y., Kanai, K., and Hiroi, K.,
TEMPERATURE DEPENDENCE OF DAMPING CAPACITY OF SOME BINARY MIXED RESIN COATINGS, Kogyo Kagaku Zasshi, Vol. 59, 1956, pp. 231-236.

The logarithmic decrement of films was determined by means of vibrational methods at 20° to 120° employing films coated on aluminum or glass plates. The resins examined were binary systems, such as (1) butylated melamine-alkyd phthalate, some natural oil added, (2) unsaturated polystyrene-styrene, (3) phenolic resin-alkyd, with castor oil, (4) nitrocellulose-vinyl resin, polyvinyl acetate, and polyvinyl butylate, etc.

227. Institute der Foerster, West Germany (In United States of America, Magnaflux Corporation, Chicago, Illinois),
A NEW METHOD FOR THE DETERMINATION OF THE MODULUS OF ELASTICITY AND DAMPING AUTOMATICALLY AND CONTINUALLY, USING FREQUENCY MEASUREMENTS by F. Foerster, 1956.

This paper describes some of the metallurgical tests performed with the Elastomat instrument in Europe. The principle is as follows: an electrical oscillator feeds an electromechanical vibration system below which a test rod sample is suspended by a thin wire. The mechanical vibrations of the electromechanical system are transmitted to the test rod through the very thin suspending wire or through fine contact wires in the newest model instruments. Resonance is studied to obtain the value of E, and mechanical damping is determined from the decay time of free vibrations.

228. Jenckel, E. and Herwig, H. U.,
VIBRATION DAMPING AND FREEZING TEMPERATURE
IN COPOLYMERS, MIXTURES OF POLYMERS, AND
SOLUTIONS, Kolloid-Zeitschrift, Vol. 148, 1956, pp. 57-66.

Experimentation shows that a heterogeneous mingling of two copolymers will have two damping maxima and two freezing temperatures, which in each case are attributed to the two phases.

229. Jensen, J. W. and Rowland, J. A., Jr.,
MANGANESE-COPPER HIGH-DAMPING ALLOYS, Product Engineering, Vol. 27, May 1956, pp. 135-137.

This article examines the mechanical properties, the fabrication characteristics, and the potential applications of alloys having the unusual combination of high tensile strength and high damping capacity.

230. Jung, P. T. and Kê, T. S.,
A STUDY ON INTERNAL ADSORPTION OF CARBON IN
ALPHA-IRON BY THE METHOD OF INTERNAL FRICTION,
Scientia Sinica, Vol. 5, 1956, pp. 645-656.

The change of the height of the carbon diffusion peak was observed during the process of decarburization of an alpha-iron specimen containing a small amount of carbon, and it was found that the height of the peak first decreased and then increased with time to a maximum value twice. This indicates that the carbon adsorbed in iron goes twice into solid solution during the process of decarburization.

231. Kabin, S. P.,
DYNAMIC MECHANICAL PROPERTIES OF POLYETHYLENE
AND POLYTETRAFLUOROETHYLENE, Zhurnal Tekh-
nicheskoï Fiziki, Vol. 26, No. 12, 1956, pp. 2628-2632 (In
Russian).

The substances are studied using longitudinal vibrations at -115° to 80° C for polyethylene and from -65° to 20° C for polytetrafluoroethylene.

232. Karapetian, B. K.,
AN EXPERIMENTAL INVESTIGATION OF THE INTERNAL
FRICTION IN STONE MASONRY, Izv. Akad. Nauk ArmSSR
Fiz.-Matem. Estestv. i Tekhn. Nauk, Vol. 9, No. 8, 1956,
pp. 69-83 (In Russian).

Experiments on samples of ashlar and brick masonry are described. In the dynamic tests, the logarithmic fading decrements were investigated; in the static tests, the area of the hysteretic loop. The experiments confirm the coincidence between coefficients of fading determined directly from the oscillations of the sample and those from the hysteretic loop plotted from the static tests. As a result of these experiments it is found that the logarithmic fading decrement of masonry increases with increasing bending stress and decreasing compression stress, and is practically independent of the period of natural vibration of the masonry. Some numerical values of the decrement are presented.

233. Kawakami, M., Shiba, Y., and Iizuka, J.,
ANTIVIBRATING RUBBER, Sumitomo Denki Iho, No. 61,
1956, pp. 33-42.

The general properties of antivibration rubber, the theory of vibration insulation, and the method of designing rubber vibration absorbers are explained, and practical applications are discussed.

234. Kawasaki, M.,
ANNEAL-HARDENING AND SECULAR CHANGE OF COPPER
ALLOYS, Kinzoku, Vol. 26, 1956, pp. 755-759 and 875-880.

Anneal-hardening or abnormal hardening occurred with copper or aluminum brass, which becomes harder when cold-worked and then annealed at a low temperature (200° to 300°) below its recrystallization point. The effect of hardening on electric resistance, specific heat, and internal friction was determined.

235. Kê, T. S. and Ma, Y. L.,
INTERNAL-FRICTION PEAKS ASSOCIATED WITH THE
TEMPERING OF MARTENSITE STEELS, Scientia Sinica,
Vol. 5, 1956, pp. 19-31.

In the tempering of hardened carbon steels, the first-stage transformation occurs in the range 80° to 160°, and consists of the formation of a low-carbon martensite containing about 0.25 percent carbon and a transitional phase of carbide having a hexagonal close-packed structure called ϵ -carbide because it resembles the ϵ -phase in the iron-nitrogen system. An internal-friction peak was observed to be associated with the tempering of martensite, leading to the belief that internal-friction measurements may be applicable to the study of the mechanism of transformation.

236. Kê, T. S. and Tsien, C. T.,
MECHANISM OF THE INTERNAL-FRICTION PEAKS
ASSOCIATED WITH THE STRESS-INDUCED DIFFUSION
OF CARBON IN FACE-CENTERED-CUBIC ALLOY STEELS,
Scientia Sinica, Vol. 5, 1956, pp. 625-643.

Internal-friction peaks associated with the stress-induced diffusion of carbon were observed in four kinds of face-centered cubic manganese steels which contain manganese 18.5, 25.4, 36.0, and 9.5 percent (with nickel 8 and chromium 3 percent, respectively). The optimum internal friction occurs at about 250° when the frequency of vibration is about two cycles per second. The height of internal-friction peaks is linear with respect to the carbon content in solid solution.

237. Kê, T. S., Tsien, C. T., and Siuebao, U.,
NATURE OF INTERNAL FRICTION PEAKS DUE TO STRESS
INDUCED DIFFUSION OF CARBON IN ALLOY STEELS
WITH A FACE-CENTERED CUBIC LATTICE, Acta Physica
Sinica, Vol. 12, No. 6, 1956, pp. 607-621.

Internal friction peaks due to diffusion through an applied stress were observed in four types of manganese steel with a face-centered cubic lattice. The optimum internal friction was observed at about two cycles per second. The height of the internal friction peak varies in direct proportion to the carbon content in solid solution.

238. Keetch, W. A.,
VIBRATION CONTROL IS RELIABILITY CONTROL, Elec-
tronic Equipment, Vol. 4, January 1956, pp. 52-53.

This article describes the Robinson Aviation, Incorporated, vibration control systems. These systems are the result of a new concept, based on tailoring the mounting system to the requirements of the individual piece of equipment and utilizing resilient members fabricated of stainless-steel wire.

239. Keller, G.,
TESTING FOR DAMPING CAPACITY OF CAST IRON WITH
ULTRASONICS, Kohaszati Lapok, Vol. 11, Ontode, April
1956, pp. 73-84.

The damping capacity, measured by ultrasonics, is greatly influenced by the quantity, size, shape, and distribution of graphite particles enclosed in the matrix. A new numerical determination of damping capacity is given.

240. Kempe, W. and Kroner, E.,
DISLOCATION DAMPING OF ALUMINUM SINGLE CRYSTALS AT ROOM TEMPERATURE, Zeitschrift für Metallkunde, Vol. 47, 1956, pp. 302-304.

Damping was measured on aluminum single crystals in the 35 to 40 kc/sec region as a function of the degree of deformation. The damping increased rapidly with deformation. The attenuation of pure aluminum at room temperature in the kilocycle range is due chiefly to dislocations. Dislocation damping was classified into three divisions in which attenuation by resonance, hysteresis, or relaxation prevails.

241. Kirby, P. L.,
ANELASTIC BEHAVIOR OF GLASS DURING AN IMPACT,
Verres et Refractaires, Vol. 10, 1956, pp. 201-207.

The resilience of glass in the rigid and the viscoelastic state of high viscosity (in the range of temperatures below the lower transformation limit) is determined by the impact effect of a cold steel ball on the glass surface. The analysis of the cathode-oscillographic diagram of the impact process characterizes the instantaneous-elastic and the anelastic (delayed-elastic aftereffect portion if the experimental temperature is above the Littleton point (for $\eta = 10^{7.6}$ poises).

242. Kirby, P. L.,
RELAXATION PROCESSES IN GLASS, Faraday Society,
Transactions, Vol. 52, 1956, pp. 131-142.

The relaxation effects of retarded elastic and internal friction processes in an inorganic glass were interpreted in terms of rate process equations and the results used to determine the distribution of relaxation times.

243. Koster, W.,
DAMPING IN ANNEALED AND COLD-WORKED ALPHA IRON CONTAINING SMALL ADDITIONS OF CARBON AND NITROGEN, Publs. assoc. ing. fac. polytech. Mons, No. 3, 1956, pp. 1-13.

The purpose is to correlate the effects of heat-treatment, aging, the presence of impurities, and the variation of the logarithmic decrement in iron and steel. The amount of carbon and (or) nitrogen in solid solution was determined. The size of the particles was calculated theoretically, measured indirectly by combining the values of the damping of the oscillations with those of the coercive field, and determined directly with an electron microscope. The validity of the method thus established, a series of experiments was undertaken on the relation between the effect of various heat-treatments on iron and steel and the variation of the decrement at different temperatures; a direct relationship was established between the mechanical characteristics due to aging or cold-working and the decrement.

244. Koster, W., Bangert, L., and Evers, M.,
DAMPING PHENOMENON OF HYDROGEN IMPREGNATED TITANIUM, Zeitschrift für Metallkunde, Vol. 47, No. 8, August 1956, pp. 564-570.

Hydrogen-loaded titanium samples show two maximum points of attenuation. These are attributed to the dissolution of hydride during heating and the precipitation of hydride during cooling.

245. Koster, W., Bangert, L., and Hafner, J.,
DAMPING AND SHEAR MODULUS OF DEFORMED AND
RECRYSTALLIZED GOLD, Zeitschrift für Metallkunde,
Vol. 47, 1956, pp. 224-228, (Max-Planck Inst. Metallforsch.,
Stuttgart, Germany).

The temperature dependence of damping and of the shear modulus of cold-worked and recrystallized gold was investigated as a function of grain size and the degree of deformation up to 600°. With increasing deformation the damping maximum was suppressed by grain boundary viscosity. The damping of gold is greater than that of copper.

246. Kronenberg, M., Maker, P., and Dix, E.,
PRACTICAL DESIGN TECHNIQUES FOR CONTROLLING
VIBRATION IN WELDED MACHINES, Machine Design, Vol.
28, No. 3, 12 July 1956, pp. 103-109.

There is still opposition to the use of welds where vibration is a problem. This viewpoint is based on the erroneous assumption that vibration is worse and damping poorer in a welded structure. It is still often believed that "beefing-up" is useful for reducing vibration; that addition of large masses of high damping capacity metal is necessary to combat oscillation.

Such beefing-up is not necessary. Superior machines can be built using welded steel structures if they are properly designed for vibration control. The mass of the machine does not have to be increased.

The reasons for these statements are detailed in this article. Also described are some of the design methods found to be practical in controlling vibration in welded structures.

247. Kuhl, W. and Schroder, F. K.,
DAMPING OF ELASTICALLY MOUNTED BEAMS, Acustica,
No. 1, 1956, pp. 79-84.

Calculations have been made of the sound insulation when sound is transmitted through a spring element to the free end of a beam of infinite length and to a beam infinite on both sides. Furthermore, the effect of a loading mass, fixed to the beam at the excitation point is also studied. To some extent comparison is made with results of laboratory experiments and practical applications. In the systems

described above, a bending wave is excited on the beam by the lateral force transmitted by the spring element. The influence on the level difference of wave propagation in the coupling element and of its losses has been studied for steel and rubber springs. The properties of springs important for applications are discussed.

248. Kurtze, G. ,
KORPER-SCHOLLDAMPFUNG DURCH KORNIGE MEDIEN,
Acustica, Vol. 6, No. 1, 1956, pp. 154-159.

Not abstracted.

249. Kuzmenkov, V. I. ,
SOME TYPES OF ENERGY DAMPING IN THE CONDITIONS
OF THE THREE-DIMENSIONAL PROBLEM OF CONJUGATE
POUNDS, Sb. Nauch. Radot Baloruss, Poly: tekhn. In-ta,
No. 54, 1956, pp. 71-77 (In Russian).

Not abstracted.

250. Lazan, B. J. ,
FATIGUE UNDER RESONANT VIBRATIONS CONSIDERING
BOTH MATERIAL AND SLIP DAMPING, Society for Exper-
imental Stress Analysis, Proceedings, Vol. 15, No. 1, 1956,
pp. 1-20 (W. M. Murray Lecture).

This paper covers system damping and its influence on resonance behavior, material damping properties, and criteria for resonant strength. Slip damping at an interface and examples of both material and slip damping are examined.

251. Lazan, B. J. ,
DAMPING AND RESONANT FATIGUE BEHAVIOR OF
MATERIALS, International Conference on Fatigue of Metals,
Institute of Mechanical Engineers, Proceedings, September
1956, 14 pp.

The purpose of this paper is to analyze the general role of material (stress-strain hysteresis) damping in minimizing near-resonant fatigue stress. This is done by developing criteria, based on material properties and stress distribution in parts, for evaluating the resonant fatigue strength of parts. Material damping is assumed to be the only source of vibrational energy dissipation in these analyses.

252. Lazan, B. J. and Goodman, L. E. ,
EFFECT OF MATERIAL AND SLIP DAMPING ON RESO-
NANCE BEHAVIOR SHOCK AND VIBRATION INSTRUMEN-
TATION, American Society of Mechanical Engineers
Publication, June 1956, pp. 55-74.

A variety of methods have been used for increasing the damping of a vibrating system in order to minimize resonant amplitudes and eventual damage. The purpose of this paper is to discuss from the design engineering viewpoint two types of damping: material damping, and slip damping.

253. Lazarus, D. and Tomizuka, C. ,
Physical Review, Vol. 103, 1956, p. 115.

The diffusivities of silver and zinc in an alloy of 70 atomic percent silver and 30 atomic percent zinc have been measured over the temperature range 500° to 700° C, by using sectioning techniques. Consideration of the effects of small differences in chemical composition indicates that the activation energy varies linearly with composition. The activation energies for diffusion apparently differ significantly from the average value derived from internal friction measurements. This difference is shown to be compatible with the fundamental diffusion process in a binary system.

254. Leak, G. M. ,
BORON IN IRON AND STEEL, Metal Treatment and Drop
Forging, Vol. 23, January 1956, pp. 21-28.

A brief review of the effect of boron in iron and steel, with particular reference to its influence on hardenability shows that some fundamental information about the behavior is lacking.

255. Le Rolland, P. and Plenard, E. ,
THE RELATIVE DISSIPATION OF ENERGY PER CYCLE
OF DEFORMATION AT LOW FREQUENCY CONSIDERED
AS A SPECIFIC PROPERTY OF MATTER, C. R. Acad.
Sci. (Paris), Vol. 243, No. 20, November 1956, pp. 1488-
1490.

Vibration experiments with Plexiglas, which has a high damping capacity, show that the relative dissipation of

energy per cycle k is sensibly constant, irrespective of the amplitude and frequency of the vibration and of the dimensions of the test specimen. For materials such as brass, k tends towards a constant value (within about 10 percent for small amplitudes of vibration).

256. Li, C. Y. and Nowick, A. S.,
ATOMIC MOBILITY IN A Cu-Al ALLOY AFTER QUENCHING AND NEUTRON IRRADIATION, Physical Review, Vol. 103, 1956, pp. 294-303.

Atomic mobility in a copper-aluminum (17 atomic percent aluminum) solid solution was studied by anelastic relaxation methods. Measurements were made under equilibrium conditions, after quenching, and after neutron irradiation.

257. Loschner, G.,
INTERNAL FRICTION IN METALS, Die Technik, Vol. 11, 1956, p. 289.

A general review is given of the various mechanics of damping observed in metals and alloys.

258. Lücke, K.,
ULTRASONIC ATTENUATION CAUSED BY THERMOELASTIC HEAT FLOW, Journal of Applied Physics, Vol. 27, No. 12, December 1956, pp. 1433-1438.

Expressions for the attenuation of sound waves in a standard linear viscoelastic body have been derived and have been applied to the attenuation due to the thermoelastic effect.

259. Lulay, J. and Wert, C.,
INTERNAL FRICTION IN ALLOYS OF MAGNESIUM AND CADMIUM, Acta Metallurgica, Vol. 4, 1956, pp. 627-631.

An order peak was observed near room temperature for all alloys in the composition range studied, 8 to 30 percent magnesium. Behavior of the internal friction for this system is quite different from that for copper-zinc and silver-zinc in the same composition range.

260. Malecki, I.,
ATTENUATION AND SCATTERING OF ULTRASONIC WAVES
IN A MEDIUM WITH SPHERICAL NONHOMOGENEITIES,
Bull. Acad. Polon. Sci. Cl. 4, Vol. 4, No. 3, 1956, pp. 173-
178.

Previous theoretical solutions of ultrasonic attenuation are extended to cover both solid and liquid media and the effect of reflections at, and mutual reactions of, inclusions.

261. Mariner, T. and Dochat, F. G.,
HOW TO REDUCE NOISE IN SHEET-METAL ENCLOSURES
WITH FLEXURAL DAMPING MATERIALS, Mechanical
Design 28, 19 April 1956, pp. 119-122.

This article outlines a procedure, designated the empirical approach, to be used whenever vibration damping is being engineered for mass-produced products involving sheet-metal panels.

The role and evaluation of damping materials is discussed. Two tables list relative damping characteristics of felt.

262. Mason, W. P.,
INTERNAL FRICTION AND FATIGUE IN METALS AT
LARGE STRAIN AMPLITUDES, Acoustical Society of
America, Journal, Vol. 28, No. 6, November 1956,
pp. 1207-1218.

A barium titanate transducer coupled to an exponential horn can produce large strains in metals. By using a final horn with a necked down section, it is possible to concentrate the strains in a small specimen. Measurements of the impressed voltage and a voltage from a pick-up electrode on the titanate make it possible to calibrate the device so that the internal friction, change in elastic constant, and the strain in the sample are all determined.

263. Mason, W. P.,
PHYSICAL ACOUSTICS AND THE PROPERTIES OF SOLIDS,
Acoustical Society of America, Journal, Vol. 28, No. 6,
1956, pp. 1197-1206.

The techniques of physical acoustics were applied in determining the elastic properties and internal friction of

polycrystal and single crystal metals, glasses, non-metallic crystals, high polymer materials, the diffusion of atoms, molecules and vacancies through a solid, the motion of imperfections and vacancies through a solid, the motion of imperfections, such as dislocations, and the detection of an interaction between the lattice sound vibrations and free electrons in metals at low temperatures.

264. Mason, W. P. and Bömmel, H. E.,
ULTRASONIC ATTENUATION AT LOW TEMPERATURES
FOR METALS IN THE NORMAL AND SUPERCONDUCTING
STATES, Acoustical Society of America, Journal, Vol. 28,
No. 5, September 1956, pp. 930-943.

Some very pure tin samples have been obtained and large effects have been measured due to the increased conductivity at low temperatures. Six oriented samples have been measured and from the measurements the six elastic constants and six viscosity coefficients have been obtained. As the mean free path becomes longer than the acoustic wavelength, the loss is determined by a scattering process, and the loss for a given frequency approaches a limiting value in agreement with a theoretical prediction of Pippard.

265. Matta, K. and Barducci, J.,
EXPERIMENTAL INVESTIGATION ON THE ELASTIC AND
ANELASTIC BEHAVIOR OF Sb-Bi ALLOYS (PART II),
Ricerca Scientifica, Vol. 26, 1956, pp. 1160-1176.

The results of a second series of measurements are here reviewed for velocity of extensional waves and internal friction for antimony-bismuth alloys. The method employed is by exciting the bars or rectangular cross section with flexural vibrations.

266. Merkulov, L. G.,
INVESTIGATION OF THE SCATTERING OF ULTRASONIC
WAVES IN METALS, Zhurnal Tekhnicheskoi Fiziki, Vol. 26,
No. 1, 1956, pp. 64-75.

Measurements of the attenuation of longitudinal and transverse ultrasonic waves (pulses at frequencies of 0.5-110 mc/sec) in magnesium, iron and copper show that at $\lambda/D \geq 10$ (where D is the mean grain diameter) the coefficient of sound scattering γ follows Rayleigh's rule.

267. Miki, H.,
ON THE INTERNAL FRICTION OF METALS. PART II.
EXPERIMENTAL RESULTS AND INSPECTIONS, Doshisha
Engineering Review, Vol. 6, No. 4, January 1956, pp. 173-
184.

The author measured the internal friction of various metallic materials so as to ascertain, on one hand, what is the value of internal friction when measured at frequencies in the range between a few cycles per second up to thousands of cycles per second; and on the other hand, to what extent the author's theory can explain the experimental results obtained within the frequency range covering the frequency at which the internal friction is a maximum.

268. Minnesota University,
DAMPING, ELASTICITY AND FATIGUE PROPERTIES OF
TITANIUM ALLOYS, HIGH-TEMPERATURE ALLOYS,
STAINLESS STEELS AND GLASS LAMINATE AT ROOM
AND ELEVATED TEMPERATURES by E. R. Podnieks and
B. J. Lazan, March 1956, Report No. OTS PB 128211, 93 pp.

Resonant fatigue properties in form of curves determined for several characteristic types of parts of the materials named.

269. Mišek, K.,
NEW EXPERIMENTS ON THE MAGNETOMECHANICAL
PHENOMENON, Czechoslovak Journal of Physics, Vol. 6,
1956, p. 330.

A description is given of new experiments on the magnetomechanical phenomenon on a number of other ferromagnetic materials and additional data are given for nickel. The question is discussed whether irreversible magnetic processes fundamentally influence the origin of the observed internal friction peak.

270. Missouri University, School of Mines and Metallurgy,
AN INVESTIGATION OF THE INTERNAL FRICTION OF
MANGANESE-COPPER ALLOYS by E. N. Sickafus, 1956,
44 pp., Thesis.

The internal friction of manganese-copper alloys was measured in the temperature range of 20° to 270° C using a Kê-type pendulum.

271. Morris, R. E., James, R. R., and Guyton, C. W.,
A NEW METHOD FOR DETERMINING THE DYNAMIC
MECHANICAL PROPERTIES OF RUBBER, Rubber Age
(New York, New York), Vol. 78, 1956, pp. 725-731.

The bar transmission technique of measuring dynamic mechanical properties is modified so that the resonance frequency and dispersion of vibration energy above and below the resonance frequency can be measured. Representative data give results obtained with vulcanizates of natural rubber, Butyl rubber, GR-S of different types, butadiene, acrylonitrile copolymer, Neoprene, and Thiokol.

272. Morse, R. W., Tamarkin, P., and Bohm, H.,
ULTRASONIC ATTENUATION IN SUPERCONDUCTING
INDIUM, Physical Review, Vol. 101, No. 5, 1 March 1956,
pp. 1610-1611.

Measurements were made by a 10 mc/sec pulse method between 4.2° and 1.5° K on two specimens of different purity. The attenuation was about five times greater in the purer specimen; in both specimens, it fell by about 40 percent on cooling through the transition temperature, and thereafter fell as T^3 .

273. Myklestad, N. O.,
FUNDAMENTALS OF VIBRATION ANALYSIS, New York,
New York, McGraw-Hill Book Company, Incorporated,
1956, 260 pp.

The objective is to give the reader a thorough understanding of vibrations from a basic point of view rather than by presenting routine methods of analysis. A new proof of the orthogonality condition, introduction of the concept of damped modes of free vibration, new treatments of vibration instruments, and balancing are included.

274. Nakamura, K.,
VISCOELASTICITY OF CELLULOSE DERIVATIVE FILMS.
I. THE SECOND-ORDER TRANSITION POINT OF CELLULOSE ACETATE, Chemical High Polymers, Japan, Vol. 13,
1956, pp. 47-53.

The dynamic Young's moduli and the internal friction of cellulose acetate are measured as a function of temperature

at various audio frequencies. At least two dispersion regions are observed at temperatures from 20° to 220° for each, and this fact is in fair agreement with the dilatometric observation.

275. Nakayama, H. and Miki, R.,
DYNAMIC CHARACTERISTICS OF RUBBER VIBRATION
ABSORBERS IN A LOW-FREQUENCY RANGE, Chemical
High Polymers, Japan, Vol. 13, 1956, pp. 202-210.

Dynamic spring constants of rubbers were measured; Young's modulus, shearing modulus, and mechanical loss were calculated for natural rubber, incoprene, and Hycar.

276. National Advisory Committee for Aeronautics,
DETERMINATION OF THE STRUCTURAL DAMPING COEF-
FICIENTS OF SIX FULL-SCALE HELICOPTER ROTOR
BLADES OF DIFFERENT MATERIALS AND METHODS OF
CONSTRUCTION by F. W. Gibson, December 1956, Report
No. TN 3862.

Measurements were made of the internal or structural damping characteristics of six full-scale helicopter rotor blades of six different materials and methods of construction. Structural damping coefficients are presented for the first three flapwise bending modes, the first torsion mode, and the first chordwise bending mode for all blades.

277. National Advisory Committee for Aeronautics,
PLASTIC BEHAVIOR OF BINARY ALUMINUM ALLOYS BY
INTERNAL-FRICTION METHODS by R. E. Maringer, L. L.
Marsh, and G. K. Manning, 1956, Technical Note, Vol. 3681,
44 pp.

Nominal additions of 0.1, 1.0, and 2.0 percent by weight copper and magnesium to aluminum have significant effects on damping behavior. An "anomalous" internal-friction peak at about 125° has been observed in aluminum containing 1.00 percent copper and results from the interaction of dislocations and impurity particles.

278. Naval Research Laboratory,
DEVICES FOR DAMPING MECHANICAL VIBRATIONS, A
BIBLIOGRAPHY by M. Benton, December 1956, Report No.
OTS PB 121299, 101 pp.

References cover studies of vibration damping by increasing mechanical impedance of the system, by energy dissipation, or by tuned attachments, and of vibration isolation by vibration dampers, connection damping and material damping.

279. Nazarov, A. G.,
INVESTIGATION OF INTERNAL FRICTION DURING
ELASTIC VIBRATIONS, Trudi Koordinats. Soveschaniya
Poseismostoik. Str-vu, 1954, Erevan Akad. Nauk ArmSSR,
1956, pp. 131-148 (In Russian).

A concise exposition is given of results obtained by the author when analyzing questions on the dissipation of energy in conditions of nonstationary vibrations, and also in a complex stressed state. The possibilities are indicated of applying the correlations obtained for the creation of a theory of stability against seismic action and for the construction of seismic meters, simulating the vibrations of installations during earthquakes.

280. Niblett, D. H. and Wilks, J.,
INTERNAL FRICTION AND IMPERFECTIONS IN COPPER,
International Institute of Refrigeration, Bulletin, No. 2,
1956, pp. 23-30.

The effects of imperfections on internal friction of metallic crystals, in particular, at low temperatures are discussed. Two maxima of internal friction, about 32° and 75° K in cold worked copper are correlated with the movement of dislocations. The effect of impurities and irradiation by neutrons are also discussed.

281. Niblett, D. H. and Wilks, J.,
THE INTERNAL FRICTION OF COLD WORKED COPPER
AT LOW TEMPERATURES, Philosophical Magazine, Vol. 1,
No. 5, Series 8, May 1956, pp. 415-418.

A preliminary report of part of a more detailed survey of the variation of internal friction with temperature at low

temperatures of cold-worked metals. Two peaks were revealed in the plot of internal friction versus temperature, and they are considered to be of the type associated with a relaxation phenomena, such as the motion of a segment of a dislocation line.

282. Payne, A. R. ,
NONLINEARITY IN THE DYNAMIC PROPERTIES OF RUBBER, Proceedings of Third Rubber Technological Conference, London, 1954, 1956, pp. 413-438.

The paper deals with the necessity for amending the classical Newtonian equations by assuming a nonlinear stress-strain curve, in order to account for the presence of a considerable amount of second harmonic of the test frequency in the restoring forces in an elastomer in both forced-vibration and positive-displacement dynamic testers.

283. Pearson, S. and Rotherham, L. ,
INTERNAL FRICTION AND GRAIN-BOUNDARY VISCOSITY OF SILVER AND BINARY SILVER SOLID SOLUTIONS, Journal of Metals, Vol. 8, American Institute of Mining, Metallurgical and Petroleum Engineers (AIME) Transactions, Vol. 206, 1956, pp. 894-901.

The variation of internal friction with temperature for spectroscopically pure silver, and for solid solutions of silver with cadmium, indium, and tin was measured. Alloying elements increase the grain-boundary viscosity, and raise the activation energy for grain-boundary relaxation from 22,000 calories per mole for pure silver to 43,000 calories per mole for the solid solutions.

284. Perls, T. A. and Sherrard, E. S. ,
FREQUENCY RESPONSE OF SECOND-ORDER SYSTEMS WITH COMBINED COULOMB AND VISCOUS DAMPING, Journal of Research, National Bureau of Standards, Vol. 57, No. 1, July 1956, pp. 45-65.

Curves obtained with an analogue computer are presented for the magnification factor versus frequency ratio of second-order mechanical vibrating systems with combined Coulomb (constant in magnitude) and viscous (proportional to velocity) damping.

285. Person, N. L. and Lazan, B. J.,
THE EFFECT OF STATIC MEAN STRESS ON THE DAMP-
ING PROPERTIES OF MATERIALS, American Society for
Testing Materials, Preprint No. 85, 1956, 15 pp.

The effect is small for materials with little magnet-
mechanical effect, but greatly reduces the damping of Type
403 alloy which has considerable magneto-mechanical
damping.

286. Pisarenko, G. S.,
THE INFLUENCE OF GRAIN SIZE ON ENERGY DISSIPATION IN A VIBRATING MATERIAL, Izv. Kievsk. Politekhn.,
Vol. 17, 1956, pp. 316-320.

The influence of grain size on the logarithmic damping
decrement was investigated on impact samples of Armco
iron of prismatic form (210 x 20 x 5 millimeters) which had
a grain size of 40 and 70 μ respectively.

The author comes to the conclusion that the material
of larger grain has a higher damping decrement than the
finer-grained material; the difference increases with the
stress amplitude and amounts to 40 percent at a stress
value of seven kilograms per square millimeter.

287. Pisarenko, G. S.,
DAMPED OSCILLATIONS: UNDER THE ACTION OF
FORCES, DEPENDING NONLINEARLY ON THE AMPLI-
TUDE, Izv. Kievsk. Politekhn. in-Ta, Vol. 17, 1956,
pp. 321-331.

An approximate investigation is made of the free damp-
ing oscillations of a system with one degree of freedom.

288. Pisarenko, G. S.,
DISSIPATION OF ENERGY IN THE MATERIAL FOR VIBRA-
TION OF ELASTIC BODIES, Prikladnaya Matematika i
Mekhanika, II, No. 3, 1956 (In Russian).

Not abstracted.

289. Pisarenko, G. S. and Khilichevskii, V. V.,
GEOMETRICAL PARAMETERS OF A HYSTERESIS LOOP
AS CHARACTERISTICS OF THE DAMPING PROPERTIES
OF A MATERIAL, Vopr. proshkovoii metallurgii i prochnosti
materialov, Kiev, Akad. Nauk SSSR, No. 3, 1956, pp. 108-
116 (In Russian).

Formulas were obtained for determining the mean damping decrement in specimens of rectangular section; sections having the form of a segment and sections formed by the use of two radii. The experimental data in no case differ from the calculated ones by more than five percent. Formulas and graphs are given of the relationship of the mean damping decrement to the stress for turbine blades of constant and variable section; difficulties were encountered in obtaining the experimental data.

290. Pisarevskii, M. M. and Dianov, S. V.,
THE EFFECT OF NITRIDING ON THE OSCILLATION
DECREMENT IN CERTAIN STEELS AT NORMAL AND AT
ELEVATED TEMPERATURES, Energomashinostroenie,
No. 5, May 1956, pp. 22-24.

This article presents experimental data for a wide range of temperatures on certain pearlite and austenite steels widely used in turbine building. For pearlitic steels, nitriding is found to reduce the oscillation decrement; the opposite is observed in the case of austenitic steels.

291. Pitsch, W. and Lücke, K.,
THE PRECIPITATION OF CARBON FROM SUPERSATURATED
SOLUTION IN ALPHA-IRON DURING AGING,
Archiv für das Eisenhüttenwesen, Vol. 27, 1956, pp. 45-54.

The dependence of damping and electric resistance on the carbon content was determined on iron wires. Precipitated carbon caused a change of resistance of at least 20 percent of the change caused by carbon in supersaturated solution, but only 2 to 3 percent of the change in damping caused by carbon in supersaturated solution. The damping measurements gave more reliable results in studying the precipitation of carbon.

292. Popper, B. J.,
DAMPING FACTOR CALCULATIONS - SUPPLEMENTARY
REMARKS ON THE EQUATIONS GIVEN IN CALCULATING
DAMPING FACTORS FOR DASHPOT DAMPERS, Product
Engineering, April, 1956, Vol. 27, 1956, p. 199.

The author relaxes some of the assumptions and arrives at equations which are more general than those appearing in the original article.

293. Postnikov, V. S.,
CORRELATION BETWEEN TEMPERATURE AND INTERNAL
FRICTION OF SOME PURE METALS, Uchenye Zapiski
(Kemerovskii Gossudarstvenny Pedagogicheskii Institut),
Series 1, 1956, pp. 191-204.

Changes of internal friction as related to temperature investigation on aluminum, titanium, cobalt, nickel, copper, molybdenum, and tungsten after annealing at 800° C. It is experimentally demonstrated that the maximum of the internal friction (or the change of slope) is located in the range of recrystallization of a metal.

294. Postnikov, V. S. and Beliaev, M. M.,
INTERNAL FRICTION IN PLASTICALLY DEFORMED
COPPER AND ALUMINUM, Akademii Nauk SSSR., Fizika
Metallov i Metallovedenie, Vol. 2, No. 3, 1956, pp. 504-
508.

Study of the variation of internal friction in pure copper and pure aluminum with temperature and time of isothermal exposure. An analysis of the relationship suggests that processes of recovery, rather than of recrystallization, account for the change in internal friction.

295. Powers, R. W. and Doyle, M. V.,
INTERNAL FRICTION IN SOLID SOLUTIONS OF TANTALUM, Acta Metallurgica, Vol. 4, No. 3, 1956, pp. 233-242.

The internal friction of tantalum arising from the diffusion of interstitial oxygen can be described as the sum of two peaks. The 137-degree peak, at an applied frequency of 0.6 cycles per second, whose height is directly proportional to the oxygen concentration, is interpreted as arising from the diffusion of free, noninteracting interstitial

oxygen. The 162-degree peak, whose height is a quadratic function of the oxygen concentration, is believed to arise from the diffusion of oxygen atoms, each of which is interacting with another oxygen atom in its neighborhood.

296. Powles, J. G.,
THE CORRELATION OF THE MECHANICAL, DIELECTRIC,
AND PARAMAGNETIC NUCLEAR ABSORPTION FOR CER-
TAIN POLYMERS, Arch. sci. (Geneva), Vol. 9, Spec. Nos.
182-189, 1956.

A comparison of experimental results of the three methods, mechanical, dielectric, and paramagnetic nuclear absorption, gives extremely precise information for explaining those properties of solids that depend on the freedom of motion of the constituent molecules or atoms. This hypothesis was applied to polyisobutylene, polymethyl methacrylate, and polymethyl alpha-chloroacrylate.

297. Price, S. J. W., McIntyre, A. D., Pattison, J. P., and Dunell, B. A.,
STRESS-RELAXATION AND VIBRATIONAL PROPERTIES
OF SOME FIBROUS POLYMERS AT VARIOUS CONDITIONS
OF TEMPERATURE AND RELATIVE HUMIDITY, Textile
Research Journal, Vol. 26, 1956, pp. 276-283.

Stress-relaxation curves, dynamic Young's modulus, and dynamic internal friction were determined for single filaments of rayon, nylon, and polyethylene at 2° and 25°, and at several relative humidities. The dissipation of energy per cycle of vibration (measured by the product of internal friction of the filament and the frequency) increases with increasing relative humidity.

298. Pridantsev, M. V., Meshcherinova, O. N., and Piguzov, Yu. V.,
THE INVESTIGATION OF THE MECHANISM OF THE
INFLUENCE OF BORON [IN STEEL] BY AN INTERNAL
FRICTION METHOD, Doklady Akademii Nauk SSSR, Vol.
111, 1956, pp. 98-101.

Steel was prepared with 0.000, 0.004, 0.006, and 0.008 percent boron, and the curves are presented for the internal friction, Q , as a function of the various boron contents, after annealing at 900° and preliminary heating to 700°, 750°, and 800°; the Q values always show two maxima at 30° and 540°.

299. Pursey, H. and Pyatt, E. C.,
MEASUREMENT OF THE DAMPING OF METAL BAR
SPECIMENS IN MECHANICAL RESONANCE, Journal of
Scientific Instruments, Vol. 33, March 1956, pp. 123-124
(Ibid, Vol. 31, 1954, p. 248).

Apparatus for measurement of damping in kilocycle frequency range is described.

300. Rawlings, R.,
INTERNAL FRICTION IN ALPHA-IRON DUE TO INTER-
STITIAL SOLUTES, Acta Metallurgica, Vol. 4, 1956,
p. 213.

Author integrates the expressions for the anelasticity of an aggregate of randomly oriented crystals and of a wire with a $\langle 110 \rangle$ texture. The calculation for the former is in good agreement with experimentally observed values; however, the latter is not.

301. Rawlings, R. and Tambini, D.,
THE DETERMINATION OF THE ALPHA PHASE BOUND-
ARIES OF THE IRON-NITROGEN SYSTEM BY INTERNAL
FRICTION METHODS, Iron and Steel Institute, Journal,
Vol. 184, November 1956, pp. 302-308.

Solubility of Fe_4N in iron was determined using the internal friction method. Equilibrium was approached by nitriding for comparison with the results obtained by precipitation by Dijkstra.

302. Reid, T. J.,
FREE VIBRATION AND HYSTERETIC DAMPING, Royal
Aeronautical Society, Journal, Vol. 60, April 1956, p. 283.

Author includes hysteretic damping in the differential equation of motion in three different ways and proceeds to find solutions to all three for the case of free vibrations. He concludes: "A final, and perhaps slightly irrelevant, point is that the greatly increased availability and scope of general purpose analogue computers tend to make the concept of viscous damping much more significant.

303. Reshetov, D. N. and Levina, Z. M.,
DAMPING OF VIBRATIONS IN JOINTS OF MACHINE PARTS,
Vestnik Mashinostroyeniya, Vol. 36, No. 12, 1956, pp. 3-13.

This is an experimental study of vibration damping in butt and cylindrical joints, and in roller bearings. Damping of materials--structural steel and spheroidal graphite cast iron--are discussed.

304. Rogers, H. C.,
INFLUENCE OF HYDROGEN ON THE YIELD POINT IN
IRON, Acta Metallurgica, Vol. 4, No. 2, 1956, pp. 114-117.

Electrolytic iron, heat-treated in wet hydrogen to remove carbon and nitrogen, was nitrided and then water-quenched to retain maximum nitrogen in solution. The wire then was strained to provide a large number of dislocations and aged to allow the nitrogen to move to the dislocations. This treatment almost completely eliminated the damping peak. To show that an observable amount of nitrogen remained bound to dislocations, a tensile test was made and the strained wire immediately tested in the pendulum. A smaller damping peak had reappeared, showing that dislocation motion returned nitrogen to free solution as expected.

305. Rotherham, L and Pearson, S.,
INTERNAL FRICTION AND GRAIN BOUNDARY VISCOSITY
OF COPPER AND OF BINARY COPPER SOLID SOLUTIONS,
Journal of Metals, Vol. 8; American Institute of Mining,
Metallurgical, and Petroleum Engineers (AIME) Transac-
tions, Vol. 206, Section 2, August 1956, pp. 881-892.

Measurements were made of the variation of internal friction with temperature for OFHC copper, and for a series of binary solid solutions of high-purity copper with zinc, gallium, germanium, arsenic and silicon, to investigate the effect of alloying elements in substitutional solid solution on grain boundary viscosity.

306. Scheil, E. and Müller, J.,
THE DAMPING OF MECHANICAL OSCILLATIONS DURING
THE MARTENSITE REACTION, Archiv für das Eisenhüt-
tenwesen, Vol. 27, December 1956, pp. 801-805.

The beginning of the γ - α -transformation of the irreversible iron-nickel alloys can be recognized much

earlier on the damping curve of mechanical oscillations than on the curves of the elasticity modulus and the electrical resistivity.

307. Schoeck, G.,
MOVING DISLOCATIONS AND SOLUTE ATOMS, Physical Review, Vol. 102, Series 2, June 1956, pp. 1458-1459.

In the stress field of a moving dislocation, stress-induced local rearrangement of solute atoms takes place. From this rearrangement there results a friction force, which depends on the velocity of the dislocation.

308. Seeger, A.,
ON THE THEORY OF THE LOW-TEMPERATURE INTERNAL FRICTION PEAK OBSERVED IN METALS, Philosophical Magazine, Vol. 1, Series 8, No. 7, July 1956, pp. 651-662.

The relaxation phenomenon is thought to be due to dislocations which are confined by the Peierls stress to certain crystallographic directions. Under combined action of thermal fluctuations and applied stress they may form pairs of kinks.

309. Seemann, H. and Finkler, H.,
DAMPING MEASUREMENTS ON PURE ALPHA-IRON AND TECHNICAL STEEL, Annales Universitatis Saraviensis, Vol. 5, 1956, pp. 87-105.

In applying the damping measurement method to technical steels, the effect of additional alloying elements must be considered. In order to obtain data on the effect of P, not studied hitherto, damping measurements were carried out on a series of alloys with different P content. Data presented show that the P content has a marked influence upon the carbon content of the iron.

310. Seemann, H. J. and Staats, H.,
INVESTIGATION OF VIBRATION PROPERTIES OF METALS IN AN ULTRASONIC REGION AT HIGHER TEMPERATURES, Zeitschrift für Metallkunde, Vol. 47, No. 9, September 1956, pp. 637-643.

A measuring arrangement which excites electro-dynamically the fundamental axial vibration mode of cylindrical

specimens. Results for duralumin, sintered aluminum, chromium-nickel steels, and a creep-resistant chromium-nickel alloy.

311. Sekiguchi, Hisayoshi and Nishimura, M.,
THE INFLUENCE OF CONTINUOUS VIBRATION ON THE
CHARACTERISTICS OF ANTIVIBRATING RUBBER, J. Soc.
Rubber Ind. Japan, Vol. 29, 1956, pp. 158-164.

The thixotropy of a hollow cylindrical antivibrating rubber cemented between two parallel metal plates was studied. When continuous vibration was applied, a thixotropic phenomenon was observed, and even after release of the vibration, continued stiffening was evident as a result of after-vulcanization or aging. The rate of decrease of the damping constant was larger than that of the spring constant.

312. Sergeev, S. I.,
THE DAMPING OF OSCILLATIONS IN MACHINERY, Trudi
Vses N-i in-ta Kinslorad, Mashinostr, No. 1, 1956, pp. 89-101.

An investigation is carried out of the damping by a linear elastic-viscous damper in a large mass system of the type similar to a rotor on a turbo-engine, or a crankshaft. Recommendations are made for selection of the optimum parameters for the damper. The differences are pointed out in the function of the damper in free and forced oscillations: in the first case, the damping proceeds by means of the dissipation of energy in the damper; in the second case, the role of the damper consists of introducing a phase shift between the exciting force and the excited displacement so that resonance phenomena becomes impossible.

313. Shinyanskii, L. A. and Solonko, V. N.,
ABSORPTION OF ULTRASONIC VIBRATIONS AS A CHARACTERISTIC OF ELASTIC PROPERTIES IN RUBBER,
Zhurnal Tekhnicheskoi Fiziki, Vol. 26, 1956, p. 2302.

The known relationship between the coefficient of absorption of ultrasonic vibrations, α , and deformation of rubber was investigated at room temperature and a frequency of 2500 kilocycles. It was shown that α was proportional to the extension of rubber test pieces and to the degree of vulcanization.

314. Slonimskii, G. L. and Alekseev, P. I.,
INVESTIGATION OF THE EFFECT OF VIBRATION ON
RELAXATION PROCESSES IN RUBBERS, Doklady Akademiia
Nauk SSSR, Vol. 106, No. 6, February 1956, pp. 1053-1056.

Additional development of deformation with and without vibration. Relation of vibration effects: average specific load and vibration amplitude; and frequency and temperature.

315. Sorokin, E. S.,
DYNAMIC ANALYSIS OF THE CARRYING STRUCTURE IN
BUILDINGS, Dinamicheskii raschet neushchikh konstruktsii
zdanii, Moscow, Gosstroizdat, 1956 (In Russian).

Not abstracted.

316. Stark, P., Averbach, B. L., and Cohen, M.,
INTERNAL FRICTION MEASURED ON TEMPERED MAR-
TENSITE, Acta Metallurgica, Vol. 4, January 1956, p. 91.

The authors made internal friction measurements on martensite in a high purity iron-low carbon alloy. The internal friction peak due to carbon migration was observed as a function of the tempering temperature. The noteworthy result is the absence of a carbon peak in as-quenched martensite.

317. State Institute of Technical Research, Finland,
METHOD FOR THE DETERMINATION OF MECHANICAL
HYSTERESIS LOOPS OF STEEL IN THE CASE OF LARGE
DYNAMIC TENSILE AND COMPRESSIVE LOADS by J.
Salokangas, 1956, Publication No. 32.

The construction of a tension compression fatigue machine based on the resonance principle is described, together with possible sources of error. The force indicator of the machine is calibrated by means of electric strain, gages to within one percent accuracy. The theoretically predicted behavior of the machine is confirmed by test measurements. In operation, oscillatory forms of force and deformation are indicated by means of coils oscillating in a magnetic field. Signals introduced into a cathode ray oscilloscope produce hysteresis loops, which can be observed continuously from beginning of tests to rupture.

Variations in hysteresis loops for different steels under uniform stress as a function of frequency of stress reversal were studied. The actual temperature of the specimen was measured during the test.

318. Staverman, A. J. and Schwarzl, F.,
THEORY AND MOLECULAR INTERPRETATION OF THE
TECHNOLOGICAL QUALITIES OF HIGH POLYMER
MATERIALS, Die Physik der Hochpolymeren, Vol. IV,
Chapter 1, Berlin, Germany, Springer-Verlag, 1956.

Not abstracted.

319. Streckis, A. M.,
FORCED VIBRATIONS OF A SYSTEM WITH ONE DEGREE
OF FREEDOM IN THE PRESENCE OF DRY FRICTION AND
WITH AN OPERATING ARBITRARY EXCITING FORCE,
Vopr. Dinamiki i Dinam, Prochnosti; Riga, Akad. Nauk
Latv. SSR, No. 4, 1956, pp. 95-121 (In Russian).

The equation: $y + k^2 y = F(t) \pm R_0$ is examined. Where $F(t)$ is the introduced theoretical exciting force, R_0 is obtained from the amplitude of the force of dry friction introduced. For the stationary process, by means of the method of the conservation of initial state, a system of equations was obtained, for the general case, for the determination of the times at which the velocity is changed to zero and the friction forces changes sign. Examples are examined where the exciting force changes by 90 degrees, without change and with change of sign, and for the case of instantaneous impulses.

320. Subrahmanyam, S. V.,
DEPENDENCE OF THE ELASTIC PROPERTIES OF CADMIUM ON TEMPERATURE, Nature, Vol. 177, 1956, p. 852.

A sudden change in the curve of (frequency)² versus temperature occurs at 130°. Single crystals of cadmium do not show the transition phenomena; this demonstrates that the mechanism involved is stress relaxation at grain boundaries.

321. Takahashi, S.,
INTERNAL FRICTION AND CRITICAL STRESS OF COPPER
ALLOYS, Physical Society of Japan, Journal, Vol. 11,
December 1956, pp. 1256-1261.

The effects of strain amplitude on the internal friction and the Young's modulus of polycrystalline specimens of copper alloys (copper-zinc, copper-aluminum, copper-phosphorus) with various concentrations of solute atoms.

322. Teutonico, L. J., Granato, A., and Truell, R.,
EFFECT OF COPPER ON ULTRASONIC ATTENUATION
IN GERMANIUM, Physical Review, Vol. 103, 1 August 1956,
pp. 832-833(L).

An attempt to decrease the ultrasonic attenuation of germanium by diffusing copper impurities is described. After vacuum heat treatment the attenuation increased; addition of the copper decreased the attenuation by factors of 3.5 and 9.

323. Thomas, W. R. and Leak, G. M.,
INTERNAL FRICTION METHODS APPLIED TO METAL-
LURGICAL PROBLEMS, Metal Treatment and Drop Forging, Vol. 23, 1956, pp. 359-366 and 413-419.

An account is given of ways of studying some metallurgical problems by internal friction techniques. The after-effect and damping which can be ascribed to the effects of interstitial solutes in body-centered-cubic iron is described. Data on measurements of diffusion coefficients, solubilities, aging, and interaction between dislocations and solute atoms is recorded.

324. Thompson, D. O. and Holmes, D. K.,
DEPENDENCE OF YOUNG'S MODULUS AND INTERNAL
FRICTION OF COPPER UPON NEUTRON BOMBARDMENT,
Journal of Applied Physics, Vol. 27, February 1956, pp. 191-
192.

The results of measurements of the "saturation" changes in Young's modulus and the internal friction of copper single crystals accompanying fast neutron irradiation were reported. The functional dependence of these properties on neutron bombardment has been obtained.

325. Thompson, D. O. and Holmes, D. K.,
EFFECTS OF NEUTRON IRRADIATION UPON THE
YOUNG'S MODULUS AND INTERNAL FRICTION OF COP-
PER SINGLE CRYSTALS, Journal of Applied Physics,
Vol. 27, 1956, pp. 713-723.

Measurements of neutron-irradiation effects upon Young's modulus and logarithmic decrement of a set of copper single crystals of 99.999 percent purity were made at room temperature. Interpretations of the results can best be given in terms of an oscillating dislocation line mechanism in which the oscillations are suppressed by the presence of interstitial atoms, vacancies, or some combination thereof.

326. Thompson, N., Coogan, G. K., and Rider, J. G.,
EXPERIMENTS ON ALUMINUM CRYSTALS SUBJECTED
TO SLOWLY ALTERNATING STRESSES, Institute of Metals,
Journal, Vol. 84, 1956, pp. 73-80.

The paper describes apparatus used to investigate the effects of slowly alternating tension and compression on single crystals of pure aluminum; the strains involved are all small--in the range 10^{-6} to 10^{-3} . The results deal with the shape of the hysteresis loop; with the nature of the creep observed when the regular alternations of stress are interrupted; with the effect of this creep on the subsequent shape of the hysteresis loop; and with the interrelation between creep rate and rate of work-hardening.

327. Thurn, H. and Wolf, K.,
COMPARATIVE DIELECTRIC AND ULTRASONIC MEA-
SUREMENTS AT 2×10^6 CYCLES ON POLYVINYL ESTERS,
POLYACRYLIC ESTERS, AND POLYVINYL ETHERS, Kol-
loid-Zeitschrift, Vol. 148, 1956, pp. 16-30.

The dielectric constants, dielectric loss factors, and mechanical loss factors are determined as a function of temperature for polyvinyl acetate, polyvinyl propionate, polymethyl acrylate, polyethyl acrylate, polybutyl acrylate, and the polymers of Me, Et, Pr, Bu, and iso-Bu vinyl ethers. The principal maximum for mechanical loss is at a lower temperature than for dielectric loss, and the half-width of the mechanical loss peak is less than that of the dielectric peak.

328. Timoshenko, V. G.,
THE APPLICATION OF A CAPACITY DEVICE FOR
RECORDING MECHANICAL VIBRATION, Problems of Powd.
Met. and Sta. of Mat (Alcod. Nauk Ukrain, SSR), Vol. 3,
1956, pp. 117-121.

The device is described schematically.

329. United States Rubber Company,
PROCESSING NATURAL AND/OR SYNTHETIC RUBBER,
B. P. 747451; Applied 12 June 1953, Filed 26 April 1954,
Published 4 April 1956.

The effect of the heat treatment of rubber/carbon-black master batches is enhanced by the presence of inorganic peroxides of magnesium, calcium, strontium, barium or zinc (particularly the latter), or of potassium persulphate. The use of these catalysts enables the production of vulcanizates, particularly of tire treads, with markedly reduced torsional hysteresis and improved wear resistance.

330. United States Rubber Company,
RUBBER TREATMENT by K. W. Doak, United States Patent
2734885, Applied 31 August 1954, Accepted 14 February 1956.

This rubber treatment is an improvement in the "low hysteresis" processing of carbon black and rubber.

331. Unterweiser, P. M.,
NEW ALLOY FOR TURBINE BLADES, Iron Age, Vol. 178,
No. 10, 1956, pp. 100-101.

The alloy described has a base composition of 65 percent cobalt and 35 percent nickel to which small quantities of iron and chromium have been added. It has a 100-hour creep rupture life of about 50,000 pounds per square inch at 1200° F.

332. Vetiska, A.,
THE FATIGUE AND DAMPING CAPACITY OF METALS
AND THEIR DEPENDENCE ON SURFACE HARDENING BY
COLD ROLLING, Hutnické Listy, Vol. 11, No. 11, 1956,
pp. 648-654.

Experiments on the damping capacity and fatigue strength of a 1.4 percent silicon and 0.55 percent chromium

steel, hardened to give a tensile strength of 19 t/in², are reported. The fatigue tests were carried out on a torsion machine. The fatigue strength was found to increase with the degree of cold work; the damping capacity showed a similar trend.

333. Veubeke, F. D.,
A VIBRATIONAL APPROACH TO PURE MODE EXCITATION
BASED ON CHARACTERISTIC PHASE LAG THEORY, AGARD
Rep. 39, April 1956, 23 pp.

This paper investigates forced motion in linear damped systems. Characteristic phase lag theory is used to define frequency response models and corresponding excitation modes which possess simple energy or orthogonality properties. The response can be expressed in a relatively simple form in terms of the characteristic phase lags, modes, and excitation. Active and reactive energy input per cycle is stationary with respect to small variations in the distribution and intensity of the exciting forces provided there is simultaneously, response and pure mode excitation. Reference is made to ground resonance testing.

334. Vineyard, G. H.,
THEORY AND MECHANISM OF RADIATION EFFECTS IN
METALS, American Institute of Mining, Metallurgical, and
Petroleum Engineers (AIME) Inst. Metals Div., Spec. Rept.
Ser. No. 3, 1956, pp. 1-12.

Methods for determining the least energy which must be imparted to an atom to displace it permanently from its site and the number of displacements are discussed as well as the changes that occur in the physical properties of metals and graphite. In general, the electric resistivity and stored energy are increased, slow neutron transmissivity is decreased while hardness, brittleness, elastic modulus, and yield strength are increased and internal friction is decreased.

335. Vodsedalek, J.,
INTERNAL DAMPING OF CHROMIUM STEELS, Materialovy
Sbornik, 1956, pp. 5-25.

This article contains definitions of the internal damping of materials, a discussion of causes, and a determination

of factors which influence damping. The magneto-mechanical component of damping is treated with great care since it plays a principal part with chromium steels at the usual cyclic tensions.

336. Vodsedalek, J.,
INTERNAL FRICTION IN AUSTENITIC STEELS,
Strofirenstvi, Vol. 6, No. 11, 1956, pp. 757-762.

Damping properties, over a wide range of loads and working temperatures, of heat resisting steels, based on iron with additions of chromium, nickel, and cobalt, used as steam turbine blade materials. Problems discussed are fatigue strength at high temperatures and effects of initial amplitude of vibration, and prolonged cyclic and static stress conditions.

337. Von Weiss, A.,
ERSCHUTTERUNGSFREIES AUGSTELLEN UND DIE
ERSCHUTTERUNGSFESTE KONSTRUKTION VON MES-
SINSTRUMENTEN, Ver Deut. Ing. Z., Vol. 98, February
1956, pp. 205-208.

The mechanical vibration of instruments by the use of springs and resilient materials is discussed and the theoretical limitations investigated.

338. Wada, Y. and Yamamoto, K.,
TEMPERATURE DEPENDENCE OF VELOCITY AND
ATTENUATION OF ULTRASONIC WAVES IN HIGH POLY-
MERS, Physical Society of Japan, Journal, Vol. 11, No. 8,
August 1956, pp. 887-892.

Measurements of velocity and attenuation of ultrasonic waves are carried out for polystyrene, polymethyl methacrylate, phenol resin, polyethylene, Nylon 6 and other commercial resins in the temperature from -60° to 90° C and at frequencies of 100 kc/sec, 1.46 mc/sec, 4.38 mc/sec and 7.30 mc/sec.

339. Waseda University, Castings Research Laboratory
FATIGUE OF CARBON STEEL BY ULTRASONIC FLAW
DETECTION METHOD by H. Yamanouchi and T. Inukai,
Report No. 7, 1956, pp. 55-58.

The values of the ultrasonic attenuation constant in mild steel under fatigue test vary with repeated stress intensity and stress cycle. These values increase in proportion to stress cycle, but a transition point exists on the curve.

340. Weertman, J.,
MASON'S DISLOCATION RELAXATION MECHANISM,
Physical Review, Vol. 101, No. 4, Series ii, 1956, pp. 1429-1430.

It is shown theoretically that Mason's dislocation-relaxation model, proposed to explain Bordoni's low-temperature internal-friction peak, probably gives rise to a peak occurring at a much lower temperature than those observed by Bordoni. In fact, it is considered that the mechanism can give rise to internal-friction peaks in the liquid-helium temperature range.

341. Weertman, J. and Salkovitz, E. I.,
DISLOCATION DAMPING, Journal of Applied Physics,
Vol. 27, No. 10, October 1956, p. 1251.

A reply to a criticism which Granato and Lucke have raised concerning previous work. A calculation is given which demonstrates that, even at the lowest strain amplitudes (5×10^{-8}) used in damping experiments, the amplitude of vibration of dislocation loops may be considerably larger than the interatomic distance.

342. Weinig, S. and Machlin, E. S.,
LOW-FREQUENCY STUDIES OF DISLOCATION INTER-ACTIONS WITH SOLUTE ATOMS, Acta Metallurgica, Vol. 4, No. 3, May 1956, pp. 262-267.

Internal friction of 99.999 percent copper and copper binary alloys investigated at 40° C in a high-vacuum torsion pendulum at one cycle per second frequency of vibration. The effects of solute additions of 0.01 to 1 atomic percent aluminum, nickel and silicon were studied.

343. Weinig, S. and Machlin, E. S.,
STRAIN-AMPLITUDE DEPENDENT INTERNAL FRICTION
STUDIES OF DILUTE ALLOYS OF COPPER, Journal of
Applied Physics, Vol. 27, No. 7, July 1956, pp. 734-738.

This paper presents an investigation of the room temperature decrement in dilute polycrystalline alloys of copper as a function of strain amplitude and annealing at a frequency of about one cycle per second. From the effect of the solute concentration and annealing temperature on the decrement, values for the binding energy for aluminum and silicon solute atoms to dislocations in copper were calculated.

344. Welber, B.,
SOME MECHANICAL PROPERTIES OF SUPERCONDUCTORS,
Proceedings of Second Cryogenic Engineering Conference,
Boulder, Colorado, 1956, p. 116.

Measurements were made of Young's modulus, E , and internal friction, Δ , of polycrystalline lead and tin at liquid-helium temperatures. For both lead and tin, the value of Δ increases with vibrational strain amplitude while E decreases, and both E and Δ increase when the specimens make the transition from super-conducting to normal states.

345. Wepner, W.,
THE DETECTION OF SMALL QUANTITIES OF CARBON
IN ALPHA-IRON BY MEASURING THE DAMPING, Archiv
für das Eisenhüttenwesen, Vol. 27, 1956, pp. 55-59.

The value of the damping measured as the logarithmic decrement or the angular loss of free oscillations is proportional to the content of the alloying element in solution.

346. Wepner, W.,
SIMULTANEOUS DETERMINATION OF SMALL CARBON
AND NITROGEN CONTENTS IN ALPHA-IRON BY MEASUR-
ING THE DAMPING, Archiv für das Eisenhüttenwesen,
Vol. 27, 1956, pp. 449-452.

A formula is developed to calculate the relation between damping and temperature to determine carbon and nitrogen.

347. Wright Air Development Center, Wright-Patterson Air Force Base, Ohio,
BIBLIOGRAPHY OF THE MATERIAL DAMPING FIELD
(WITH ABSTRACTS AND PUNCH CARD CODINGS) by L. J. Demer, June 1956, Technical Report 56-180.

This bibliography, consisting of almost 900 entries, was compiled as an aid in furthering current and future research in the field of the damping of materials and structures. An abstract of each reference is included in all but a few cases. A detailed classification system for the damping field is described which differs from the ASM-SLA Metallurgical Literature Classification only in the Processes and Property Index. Punched card codings are included with each reference in the bibliography.

348. Wright Air Development Center, Wright-Patterson Air Force Base, Ohio,
DAMPING, ELASTICITY, AND FATIGUE PROPERTIES OF TITANIUM ALLOYS, HIGH TEMPERATURE ALLOYS, STAINLESS STEELS, AND GLASS LAMINATE AT ROOM AND ELEVATED TEMPERATURES by E. R. Podnieks and B. J. Lazan, March 1956, Report No. TR 56-37.

The significance of the damping, elasticity, and fatigue properties of a material on the resonant behavior of a part is reviewed. The basic unit for expressing damping energy and a procedure for its determination are discussed. Data on damping elasticity, and fatigue properties at room and elevated temperatures are presented for four types of materials: titanium alloys, high temperature alloys, stainless steels, and glass fabric laminate. The general behavior of these dynamic properties is summarized with regard to the significance of the more important variables. The resonant fatigue properties in the form of resonant fatigue curves are determined for several characteristic types of parts by using the above materials. A comparison is made for the materials under different design criteria.

349. Wright Air Development Center, Wright-Patterson Air Force Base, Ohio,
EFFECT OF FATIGUE STRESS HISTORY ON ELASTIC PROPERTIES AND STRESS DISTRIBUTION UNDER ROTATING BENDING by L. C. Lidstrom and B. J. Lazan, August 1956, Technical Report 56-122, 48 pp.

Data are presented on the effect of fatigue stress amplitude and number of cycles on the stress-strain properties of mild steel under reversed axial (tension-compression) stress. Cyclic stress near the fatigue limit is shown to have a significant effect on the stress-strain properties and secant modulus of the material. The general significance of the observed changes in modulus properties on the stress distribution in a rotating beam are discussed.

350. Wright Air Development Center, Wright-Patterson Air Force Base, Ohio,
MATERIAL-PROPERTY-DESIGN CRITERIA FOR METALS. PART 4. ELASTIC MODULI: THEIR DETERMINATION AND LIMITS OF APPLICATION by S. A. Gordon, R. Simon, and W. P. Archbach, October 1956, Report No. TR 55-150, 18 pp.

A study was made of the modulus of elasticity of several materials at elevated temperatures, as derived from the conventional stress-strain curve and as derived from determination of the velocity of propagation of elastic waves. Both methods of determination give modulus values which agree closely in regions of low stress where time effects are unimportant. At higher stress levels, where the stress-strain relationships are not linear and where time effects are important, the dynamic modulus is higher than the statically determined modulus. The differences determined for the magnesium alloy A8-31 and the aluminum alloy 2024-T4 for various temperatures are discussed in respect to their applicability to airframe design.

351. Wright Air Development Center, Wright-Patterson Air Force Base, Ohio,
SLIP DAMPING OF PRESS-FIT JOINTS UNDER LINEARLY VARYING PRESSURE by J. H. Klumpp and L. E. Goodman, September 1956, Report No. TR-56-291.

Energy of vibration may be dissipated by microscopic slip on interfaces where machine elements are joined in a

press fit. This report develops expressions for the damping and elastic properties of joints under a linearly varying clamping pressure. The predictions of the theory are compared with the results of controlled experiments. Correlation is made between the linear pressure joint and a uniform pressure joint which has been previously investigated.

352. Wright Air Development Center, Wright-Patterson Air Force Base, Ohio,

THE PROPERTIES OF CONSTRUCTIONAL METALS AS A FUNCTION OF TEMPERATURE AND STRAIN RATE IN TORSION by E. P. Klier, N. Feola, A. Viggiano, and V. Weiss, November 1956, Report No. TR 56-216, AD-110 559.

Seven structural materials were tested in torsion at four strain rates and various temperatures and the torque-twist relationships determined for the three lowest strain rates. Both solid and tubular specimens were tested. The strain rates tested were 10^{-5} , 10^{-3} , and 10^{-1} , and 10 in./in./sec; the temperatures investigated ranged from room temperature to 1200° F; the materials investigated were 4340 steel in two hardness grades, 321 stainless steel, 7075-T6 aluminum, AZ-31 magnesium, RC-70 and C-130-AM titanium alloys. Data are given showing the effects of strain rate and temperature on the modulus of rupture, yield strength, proportional limit, modulus of rigidity, fracture shear strain, and the energy absorption of the various metals.

353. Zhmudskii, A. Z., Maksimyuk, P. O., and Kolesnichenko, L. F.,

MECHANISM FOR THE ARTIFICIAL AGING OF A SOLID SOLUTION OF COPPER IN ALUMINUM BY STUDYING THE INTERNAL FRICTION, Nauk. Povidomlennya Kiiiv. Univ., Vol. 1, No. 1, 1956, pp. 37-38.

The study of the internal friction in samples of copper-aluminum alloys which have undergone natural and synthetic aging of different duration showed that the two types of aging are not identical, and that in going from natural to synthetic aging, the phase which is deposited during the former goes back into solution, after which a phase is deposited which corresponds to the synthetic aging.

354. Zucker, C.,
ULTRASONIC ABSORPTION IN METALS AT ELEVATED
TEMPERATURES, Acoustical Society of America, Journal,
Vol. 28, No. 4, July 1956, pp. 721-723.

The use of the ultrasonic pulse technique as a means of measuring ultrasonic absorption in an aluminum alloy (2S) at high temperatures has been considered. The absorption for both the longitudinal and shear waves was computed. These measurements show that the absorption is relatively constant up to approximately 200° C where it then experiences a large increase. The major part of the absorption at high temperatures is found to be due to thermal effects.

355. Academy of Structures and Institute for Structural Design, Moscow,
INTERNAL AND EXTERNAL RESISTANCES FOR VIBRATIONS OF SOLID BODIES by E. S. Sorokin, 1957, 65 pp.

The results of experimental and theoretical investigations on the problem of internal and external friction in vibrations are presented. The author concludes that it is possible to represent dissipative forces of different kinds by one complex expression. This result can be used in the solution of practical dynamic problems in which it is necessary to take into account resistance of various kinds. A small amount of data is given for glass, wood, and reinforced concrete.

356. Akhiezer, A. I., Kaganov, M. I., and Liubavskii, G. I.,
ULTRASONIC ABSORPTION IN METALS, Zhurnal Eksperimental'noi i Teoreticheskoi Fiziki, Vol. 5, November 1957, pp. 685-688.

The absorption coefficient for metals and its temperature dependence have been computed.

357. Arnold, R. N.,
RESPONSE OF AN IMPACT-VIBRATION ABSORBER TO FORCED VIBRATION, Ninth International Congress of Applied Mechanics, University of Brussels, Vol. 7, 1957, pp. 407-418.

Not abstracted.

358. Asanuma, M. and Ogawa, S.,
MAGNETIC AGING OF COMMERCIAL PURE IRON, Physical Society of Japan, Journal, Vol. 12, 1957, pp. 955-958.

Magnetic susceptibility and internal friction were measured to study the cause of magnetic aging in iron. Small amounts of carbon and nitrogen were responsible, nitrogen being more effective than carbon, especially during the formation of an intermediate nitride. Nitrogen may have a different effect than carbon.

359. Atomic Energy Commission,
INTERNAL FRICTION AND SHEAR MODULUS OF THORIUM
AT HIGH TEMPERATURES by C. E. Dixon and H. Hari,
1957, Report No. NAA-SR-1846, 12 pp.

Internal friction and shear modulus were measured on iodide-processed thorium wire with a torsion pendulum, in vacuum, at temperatures between 20° and 800°. In small-grained specimens, a grain-boundary internal-friction peak was observed at about 530° along with a corresponding relaxation of the shear modulus.

360. Awatani, J. and Miyamoto, H.,
ABNORMAL DECAY PATTERNS FOR ULTRASONIC WAVES
IN METAL RODS, Institute of Scientific and Industrial
Research, Osaka University Memoirs, Vol. 14, 1957, pp. 47-
52.

Anomaly in decay patterns observed in attenuation measurements is investigated for longitudinal ultrasonic waves in cylindrical rods. Anomaly appears to be due to interference among several modes excited in the rod by a quartz crystal transducer, and residual stresses or fiber structure resulting from production processes.

361. Baker, G. S.,
INTERNAL FRICTION IN THE PRESENCE OF A STATIC
STRESS, Journal of Applied Physics, Vol. 28, No. 6,
June 1957, pp. 734-737.

The internal friction of pure lead, copper, and aluminum single crystals was measured as a function of an externally applied static biasing stress. The low-strain amplitude damping of copper and lead was found to be essentially unaffected by the presence of the static stress. Aluminum differs from lead and copper in that at room temperature, damping is independent of amplitude at low-strain amplitudes ($\epsilon \times 10^{-6}$). The damping in aluminum becomes strain-amplitude dependent only at higher strain amplitudes. The presence of the static stress causes this amplitude dependence to shift to lower stress amplitudes by an amount comparable to the static stress applied.

362. Battelle Memorial Institute, Titanium Metallurgical Laboratory, Columbus, Ohio,
THE DAMPING CAPACITY OF TITANIUM AND TITANIUM ALLOYS by R. E. Maringer, 23 July 1957.

Available data on the damping of titanium and titanium alloys are reviewed.

363. Beyer, R. T. and Jacob, K. C.,
QUESTION OF ULTRASONIC ABSORPTION PEAKS IN ETHYL ACETATE, Acoustical Society of America, Journal, Vol. 29, No. 9, September 1957, p. 1034.

Available ultrasonic absorption data for ethyl acetate are considered, including some recent evidence for two distinct relaxation peaks. Experimental and theoretical considerations suggest that the reported peak below 10 mc/sec is spurious.

364. Blatt, F. J.,
ULTRASONIC ATTENUATION IN GERMANIUM AND SILICON, Physical Review, Vol. 105, No. 3, 1 February 1957, pp. 1118-1119.

This article suggests an experimental procedure which may shed additional light on intervalley scattering and may permit a direct determination of the coupling constant for this process.

365. Brown University, Providence, Rhode Island,
SURVEY OF THE RECOVERY OF DAMPING AND MODULUS CHANGES FOLLOWING PLASTIC DEFORMATION by A. Hikata and A. Granato, January 1957, Report No. AF OSR TN 57-54.

Not abstracted.

366. Butta, E.,
SOUND VELOCITY AND DAMPING IN ZIEGLER POLYTHENE, Journal of Polymer Science, Vol. 25, 1957, pp. 239-242.

Sound velocity and damping in an unbranched, highly crystallized polyethylene (I) and in branched, com. polyethylenes (II) were measured from -70° to the melting point. The damping factor for II reaches a maximum at 52° , whereas that for I increases regularly with increasing temperature.

367. Chernikova, I. N.,
INVESTIGATION OF THE TEMPERING OF HARDENED
STEEL BY USING THE METHOD OF INTERNAL FRICTION,
Akademii Nauk, SSSR, Fizika Metallov i Metallovedenie,
Vol. 5, No. 1, 1957, pp. 102-105 (In Russian).

The internal friction was studied of five carbon steels containing, respectively, 0.015, 0.28, 0.35, 0.46, and 0.58 percent by weight carbon. For steel containing 0.015 percent carbon, a "low-temperature peak" was detected at about 40° C, which is attributed to the presence of carbon atoms in the alpha-iron lattice forming a solid solution. It is shown that the internal-friction peak at 200° C can be used for characterizing the relaxation process which accompanies the separation of carbon from the solid solution of alpha-iron during tempering.

368. Chernikova, I. N.,
STUDY OF THE PROCESSES OF TEMPERING BY MEANS
OF THE METHOD OF INTERNAL FRICTION, Akademii
Nauk, SSSR, Fizika Metallov i Metallovedenie, Vol. 5,
No. 1, 1957, pp. 176-177 (In Russian).

The temperature dependence of the internal friction is graphed for specimens hardened to obtain martensite with various carbon contents (0.015, 0.035, 0.46, and 0.58 percent by weight). The magnitude of the peak at 200° C is proportional to the carbon content. After a one-hour tempering at 100°, 200°, 300°, 400°, 500°, and 600° C, the level of the peak is reduced for the specimens containing 0.35, 0.46, and 0.58 percent by weight carbon.

369. Clarebrough, L. M.,
INTERNAL FRICTION OF BETA-BRASS, Acta Metallurgica,
Vol. 5, 1957, pp. 413-426.

The internal friction of polycrystals and single crystals of 11 alloys containing 43.81 to 51.62 percent by weight zinc was measured by the method of low frequency (approximately one cycle per second), free, torsional vibration of a wire specimen. By varying the composition and heat-treatment, specimens were obtained which gave maxima in the plots of internal friction against temperature at approximately 70°, 177°, 190°, 285°, and 300°. In addition, for all compositions

and all heat treatments, the internal friction reached extremely high values at temperatures close to the order-disorder transformation temperature.

370. Cornell University, Ithaca, New York,
INTERNAL FRICTION AND YOUNG'S MODULUS OF PURE
COPPER SINGLE CRYSTALS IN THE TEMPERATURE
RANGE 25 TO 750 DEGREES by L. A. Kamensky, 1957,
Thesis (University Microfilms, Ann Arbor, Michigan,
Publication No. 21088, 137 pp.; Dissertation Abstracts,
Vol. 17, p. 1096, 1957).

The low temperature results were compared with the theory of Grantao and Lucke. The agreement with the amplitude dependent portion of the internal friction was good. However, no adequate theory seems to exist at present which describes the amplitude independent part. At higher temperatures, the Granato-Lucke theory does not seem to give good agreement. Based on the assumption that dislocations are no longer pinned by impurity atoms but are constrained by dislocations in other glide planes, the amplitude and temperature dependence of the internal friction can be derived.

371. Cornell University, Ithaca, New York,
INTERNAL FRICTION STUDIES IN IMPURITY DAMPED
SINGLE COPPER CRYSTALS by R. R. Stevens, Jr.,
1 February 1957, Report No. AFOSR-TR-57-11.

The temperature dependence and amplitude dependence of the internal friction of impurity-doped single copper crystals were measured in the temperature range of 27° to 900° C and in the strain amplitude range of 10^{-8} to 10^{-5} at frequencies in the kilocycle range. The method of measurement consisted of exciting reeds in transverse modes of vibration and then determining the decay time of the resulting free damped vibrations.

372. Darling, A. S.,
INTERNAL FRICTION OF PLASTICALLY DEFORMED
COPPER, Institute of Metals, Journal, Vol. 85, August
1957, pp. 489-505.

Investigation of the effect of plastic deformation upon the internal friction of tough-pitch and high-purity copper

by means of a torsion pendulum having a low background energy loss. The internal-friction effects induced by plastic deformation can be eliminated from tough-pitch copper, and reduced in high-purity copper, by annealing at 160° C.

373. Davidson, H. W., Losty, H. H. W., and Ross, A. M.,
MECHANICAL PROPERTIES OF GRAPHITE AT ELEVATED
TEMPERATURES, Ind. Carbon and Graphite, Papers
Conference, London, 1957, pp. 551-559.

The Young's modulus and the internal friction of graphite were measured over the temperature range 20° to 1900°, freely vibrating U-shaped cantilever specimens being used in the frequency range 25 to 40 cps. The measurements of internal friction showed an initial decrease with increasing temperature followed by a more rapid increase.

374. Deeg, E.,
THE EFFECT OF AGING ON THE INTERNAL FRICTION
OF PLATE GLASS AND A TEMPERATURE ANOMALY IN
THE INTERNAL FRICTION OF QUARTZ GLASS, Naturwis-
senschaften, Vol. 44, No. 10, 1957, p. 303.

Measurements are conducted up to almost 900° C, with small peaks observed at about 150° and 550° C.

375. Dixon, C. E. and Hari, H.,
INTERNAL FRICTION AND SHEAR MODULUS OF THORIUM
AT HIGH TEMPERATURES, Second Nuclear Engineering
and Science Conference, New York, American Society of
Mechanical Engineers, Paper 57-NESC-6, 1957.

The internal friction and shear modulus of thorium were measured at temperatures in the range of 20° to 800° C. The results are explained in terms of grain-boundary relaxation.

376. Dmitrievskii, S. E.,
SOME THEORIES REGARDING VIBRATIONS WITH
"NATURAL DAMPING" AND THEIR EVALUATION IN THE
LIGHT OF THE EXPERIMENTAL DATA, Trudi Vses.
Zaochn. In-ta Pishch. Prom-sti, Vol. 2, 1957, pp. 5-83.

The possibility is investigated of being able to evaluate the internal friction of resistance in differential equations

describing the process of vibration of a simple mechanical oscillator as exemplified, for instance, by the forced vibrations of a foundation when taking into account the internal forces of resistance. The author proposes to consider the internal forces of resistance by utilizing polynomials of the second degree to relate deformation and resistance. The equation for the free vibrations of the system, in conformity with the above hypothesis, can be recorded in the form of

$$\ddot{x} + p^2x + \alpha x \sin x \sin x + \beta x^2 \sin \dot{x} = 0$$

where p , α , and β are constants.

377. Donth, H.,
ON THE THEORY OF THE LOW-TEMPERATURE INTERNAL FRICTION PEAK IN METALS, Zeitschrift für Physik, Vol. 149, No. 1, 1957, pp. 111-130.

This article presents a detailed study of the mechanism proposed by Seeger. Pairs of kinks are formed in a dislocation line when its energy of oscillation about a potential energy minimum exceeds a critical value. This energy is obtained through interaction with the thermal vibrations of the lattice. The critical value is not reached spontaneously but by a series of small changes as in a stochastic process. The general theory of such processes is used to obtain an expression for the relaxation time for the formation of kink pairs. An activation energy is introduced and the theoretical expression for this is compared with a value obtained from measurements by Bordoni.

378. Dow Chemical Company, Midland, Michigan,
DAMPING CHARACTERISTICS OF SOME MAGNESIUM ALLOYS, Magnesium Technical Service and Development, Letter Enclosure, 1 August 1957.

Data are presented for various cast, extruded, and forged magnesium alloys.

379. Eisele, F. and Bauer, W.,
INVESTIGATION ON DAMPING CHARACTERISTICS OF VARIOUS CAST STEELS, Forsch.-und-Konstr. Wzm. (FoKoMa), Vol. 3, 1957, pp. 109-123.

The mechanical properties of a group of cast steels were investigated in regard to composition. The specimens

were tested in torsion and flexure. Damping is expressed in terms of an "energy decrement". Curves of energy decrement versus strain amplitude are given for each specimen.

380. Eisele, F. and Drumm, H.,
STIFFNESS AND DAMPING OF WELDED CONSTRUCTION
ELEMENTS, Forsch. -und-Konstr. Wzm. (FoKoMa), Vol.
3, 1957, pp. 125-128.

Logarithmic decrement measurements were used to evaluate the damping characteristics of a variety of welded joints. Specific welding configurations are suggested for corner joints, T-joints, lap joints and others to maximize total damping.

381. Entwistle, K. M.,
DAMPING BEHAVIOR OF QUENCHED ALUMINUM-COPPER-
MAGNESIUM-SILICON ALLOYS, Institute of Metals, Journal,
Vol. 85, 1957, pp. 425-430.

The transient damping maximum observed during the aging of a quenched aluminum-copper-magnesium-silicon alloy occurs in supersaturated single-phase solid solutions of the same alloy series. The progressive increase of the damping effect with degree of supersaturation can be used to determine the solid solubility limits at the temperature of solution treatment.

382. Faraday, B. J. and Gregan, D. J. C.,
EXPERIMENTAL STUDY OF MECHANICAL DISSIPATION
IN BUTT-JOINTED ADP CRYSTAL PLATES, Acoustical
Society of America, Journal, Vol. 29, No. 9, September
1957, pp. 1001-1004.

Two principal factors considered for butt-joined bonds were the thickness of the bond and its relative position along the overall length of crystal. The dissipation factor, the reciprocal of the mechanical Q , was measured for variable thickness of bond, keeping the position constant, and for variable position, keeping the thickness constant. These tests indicated that the thickness should be kept at a minimum and that the bond should be located away from the position of the antinode of stress and strain.

383. Federighi, T. and Gatto, F.,
INFLUENCE OF COPPER CONTENT ON THE INTERNAL
FRICTION OF ALUMINUM-COPPER ALLOYS, Aluminio,
Vol. 26, 1957, pp. 157-161.

It was shown by experiments on samples taken from extrusions and rolled material, that copper in quantities as small as 0.25 percent reduced the aluminum internal friction. This reduction was independent of the purity of material and of the frequency of sample vibration.

384. Filekin, V. P.,
DETERMINATION BY OSCILLOGRAM READINGS OF
RESISTANCE FORCES OF NONLINEAR DAMPING VIBRA-
TIONS OF AN ELASTIC SYSTEM, Trudi Kuibyshevsk.
Aviats. in-ta, No. 3, 1957, pp. 239-245.

The problem of finding the form of the nonlinear relation between the force of resistance and the velocity during vibration of heterogeneous rods and plates is investigated. It is shown that the problem is solved on the basis of analysis of oscillograms of the damping vibrations of the sample under test, by means of the application of the asymptotic methods of nonlinear mechanics. A concrete example of the calculations is given. The conditions for smallness of the small parameters, on the degree of which the resolution is effected, are not determined in the paper.

385. Fine, M. E. and Chiou, C.,
ACOUSTIC RELAXATION EFFECT IN Mn_3O_4 , Physical
Review, Vol. 105, 1957, pp. 121-122.

Internal friction effects in hausmannite were attributed to stress-induced change in the Mn^{++} - Mn^{+++} distribution. The activation energy is 0.4 electron volts per unit of process responsible for the internal friction.

386. Fine, M. E.,
APPARATUS OF PRECISE DETERMINATION OF DYNAMIC
YOUNG'S MODULUS AND INTERNAL FRICTIONS AT ELE-
VATED TEMPERATURES, Review of Scientific Instruments,
Vol. 28, August 1957, pp. 643-645.

Apparatus for determining Young's modulus and internal friction of metals at temperatures to 800° C.

387. Finkelshtein, B. N. and Usova, L. F.,
INVESTIGATION OF AGING OF TECHNICAL IRON BY THE
METHOD OF INTERNAL FRICTION, Shornik Moskov Inst.
Stali, Vol. 36, 1957, pp. 176-190.

Three technical irons from different melts were investigated by measuring the rate of decay of low-amplitude torsional vibrations. The same samples were investigated during aging by measuring the coefficient of shear, and Young's modulus, and were examined under the optical and electron microscopes. Aging proceeds in three periods: 1) the velocity of decomposition of a solid solution is low; 2) a rapid increase of the velocity of decomposition, an achievement of maximum values, and a rapid drop of the velocity of decomposition; 3) a slow decrease of the velocity of decomposition. The amount of separated phase at different times of aging was determined. During aging, the modulus of elasticity does not change.

388. Flint, C. F.,
FUNDAMENTAL PROPERTIES OF ENGINEERING RUBBERS:
TESTING A COMPOUNDING INGREDIENT, Rubber Journal
and International Plastics, Vol. 133, 1957, pp. 651-654, 667,
696-698, 702.

The modulus of elasticity in compression is described, and the difference between static and dynamic moduli emphasized. Creep, permanent set, and damping are described. Descriptions of the Roelig mechanical oscillator for demonstrating damping, and the Yerzley oscillograph for demonstration of the compression properties are given.

389. Forry, K. E.,
TWO PEAKS IN THE INTERNAL FRICTION AS A FUNCTION
OF TEMPERATURE IN SOME SODA SILICATE GLASSES,
American Ceramic Society, Journal, Vol. 40, 1957, pp. 90-
94.

Internal friction was measured on three soda silicate glasses with Na_2O varying between 17 and 34 percent. The internal friction varied with temperature and indicated two maxima. One peak occurred in the temperature range -50° to 50° F and the other between 300° and 500° F. The position of the peaks was dependent on the soda concentration.

390. Gebhardt, E. and Seghezzi, H.,
APPARATUS FOR STUDY OF GAS-METAL SYSTEMS AND
RESULTS OF MEASUREMENTS ON THE TANTALUM-
OXYGEN SYSTEM, Zeitschrift für Metallkunde, Vol. 48,
August 1957, pp. 430-435.

This article describes an apparatus that permits direct and indirect heating of a metal wire or band to its melting point. Results are presented for damping and electrical resistance behavior during degassing of tantalum. Electrical resistance of tantalum increases linearly with concentration of oxygen dissolved in lattice.

391. Gibbons, D. F.,
ACOUSTIC RELAXATIONS IN FERRITE SINGLE CRYSTALS,
Journal of Applied Physics, Vol. 28, No. 7, July 1957,
pp. 810-814.

Acoustical wave attenuation measurements showed the existence of two types of stress-induced relaxations, and a transformation in the ferrites was examined. A loss mechanism due to stress-induced electron migration of the type $\text{Fe}^{+++} + e = \text{Fe}^{++}$, with an activation energy of 0.03 to 0.004 electron volts per electron jump, appears to be common to all ferrites containing di- and trivalent ferrous ions on the octahedral sites. A stress-induced relaxation was demonstrated in manganese ferrite, with an activation energy of about 0.3 electron volts per unit process. Finally, a transformation was observed in manganese zinc ferrite near 10°K , the temperature depending upon composition.

392. Graft, W. H. and Rostoker, W.,
THE MEASUREMENT OF ELASTIC MODULUS OF TITANIUM ALLOYS, American Society of Testing Materials Symposium on Titanium, 1957, pp. 130-144.

The principles and advantages of the dynamic methods of measurements are reviewed and the apparatus used is described. Results given on the effect of the elastic modulus, nitrogen of alloying with aluminum, zinc, tin, chromium, molybdenum and vanadium. The effects of aging on nitrogen are also considered.

393. Granato, A. and Lücke, K.,
ON THE ORIENTATION DEPENDENCE OF INTERNAL
FRICTION, Journal of Applied Physics, Vol. 28, May 1957,
p. 634.

The dependence of the decrements and modulus changes having their origins in dislocation motion upon the crystal orientation and the errors which may occur when the orientation is not given are discussed. An example of the difficulty involved in comparing measurements taken at high and low frequencies is given. The possibility that this effect has a bearing on the discrepancies found in attempts to measure the frequency dependence of internal friction in the kilocycle range is proposed.

394. Great Britain Aeronautical Research Council,
CONCEPT OF COMPLEX STIFFNESS APPLIED TO PROBLEMS OF OSCILLATIONS WITH VISCOUS AND HYSTERETIC DAMPING by S. Neumark, September 1957, Report R and M No. 3269, 34 pp.

It is shown in the paper that current expressions for complex stiffness are different in the cases of forced and free oscillations. All fundamental cases for a single degree of freedom are critically reexamined and compared, and fallacious solutions eliminated.

395. Grin, A. V.,
THE INFLUENCE OF MAGNESIUM UPON THE INTERNAL FRICTION AT THE GRAIN BOUNDARIES AND THE BLOCKS OF THE MOSAIC STRUCTURE IN ALLOYS OF ALUMINUM WITH MAGNESIUM, Akademii Nauk, SSSR, Fizika Metallov i Metallovedenie, Vol. 4, 1957, pp. 561-563.

Curves are presented for aluminum which is alloyed with 0.01, 0.05, 1.0, and 2.0 percent magnesium, for a temperature range of zero to 700°, and grain sizes of 0.07, 0.1, 0.15, 0.3, 0.5, and 2 millimeter of the alloys, for the internal friction. All these curves have maxima, and all the maxima have been plotted (for 300°) as a function of the magnesium contents.

396. Grin, A. V. and Pavlov, V. A.,
INTERNAL FRICTION OF ALUMINUM-MAGNESIUM
ALLOYS ON DEFORMATION, Akademii Nauk, SSSR, Fizika
Metallov i Metallovedenie, Vol. 4, No. 1, 1957, pp. 103-111.

This article investigates the thermal relationship of internal friction of aluminum-magnesium alloys on deformation, and presents a new maximum of internal friction dependent on magnesium diffusion. The value of the maximum shifts at higher temperatures with increase of magnesium concentration in solid solution.

397. Grin, A. V.,
INTERNAL FRICTION IN RECRYSTALLIZED ALUMINUM-
MAGNESIUM ALLOYS, Akademii Nauk, SSSR, Fizika
Metallov i Metallovedenie, Vol. 4, No. 2, 1957, pp. 383-384.

This article presents a study of the torsional vibration method of the relationship between temperature and internal friction in recrystallized alpha solid solution of magnesium and aluminum for 0.01 magnesium, 0.05, 0.5, 1, and 2 percent.

398. Guillet, L. and Gence, P.,
CONTRIBUTION TO THE STUDY OF ANOMALIES IN THE
INTERNAL FRICTION OF IRON DUE TO THE PRESENCE
OF NITROGEN IN SOLUTION, Iron and Steel Institute,
Journal, Vol. 186, 1957, pp. 223-226.

Behavior of a low-carbon steel when subjected to cyclic stresses at various temperatures is studied. Peak values of internal friction are related to resonant oscillation of nitrogen atoms in the alpha-iron lattice. Critical temperatures are presented for maxima in internal friction at frequencies from 332 to 15,000 cycles.

399. Hagel, W. C. and Clark, J. W.,
SPECIFIC DAMPING ENERGY OF FIXED-FIXED BEAM
SPECIMENS, Journal of Applied Mechanics, Vol. 24,
September 1957, pp. 426-430.

Internal damping effects of varying composition, heat treatment, cold work, magnetic field strength, stress history, and static tension studied at room temperature on AISI 403 steel by fixed-fixed beam specimens supported in new bending vibration-decay apparatus.

400. Hamme, R. N.,
MATERIALS AND TECHNIQUES FOR DAMPING VIBRATING
PANELS, Noise Control, Vol. 3, No. 2, March 1957, pp. 23-
26.

Vibration damping techniques correctly applied to panel systems can yield large-magnitude noise reductions. The range of application of these techniques and appropriate methods and materials are discussed.

401. Harding, J. V.,
DAMPING CAPACITY, The Engineer, Vol. 203, No. 5284,
3 May 1957, pp. 671-673.

This article is concerned with the application of damping capacity in engineering, with particular reference to cast iron. On an engineering scale, damping capacity changes of a small magnitude are of little interest, but the very large differences in different materials and at different stress levels have an important effect, and should be taken into account more than they are.

402. Hikata, A. and Truell, R.,
FREQUENCY DEPENDENCE OF ULTRASONIC ATTENUA-
TION AND VELOCITY ON PLASTIC DEFORMATION, Journal
of Applied Physics, Vol. 28, May 1957, pp. 522-523.

Dependence of ultrasonic attenuation and velocity on plastic deformation in 2S aluminum is compared at two frequencies, 5 and 10 megacycles. The comparison shows agreement, as regards frequency dependence, with what can be expected from dislocation damping theory.

403. Hino, J., Tomizuka, C., and Wert, C.,
INTERNAL FRICTION AND DIFFUSION IN 31% ALPHA
BRASS, Acta Metallurgica, Vol. 5, 1957, pp. 41-49.

The diffusion constants were measured by radioactive tracer techniques with Zn^{65} and Cu^{64} . Single-crystal specimens were used to minimize the short circuiting grain boundary paths. In the internal-friction experiments, the relaxation time of the order peak was measured over 9 cycles of 10, corresponding to data obtained in the range 175° to 575° . Since the activation energy for the internal friction phenomenon was significantly different from that

for diffusion of either of the constituent metals, it is presumed that the internal-friction phenomenon is not simply related to radioactive diffusion.

404. Hoffman, L. C. and Weyl, W. A.,
SURVEY OF THE EFFECT OF COMPOSITION ON THE
INTERNAL FRICTION OF GLASS, Glass Industry, Vol. 38,
1957, pp. 81-85.

Internal friction peaks for Li^+ and K^+ ions were observed in addition to the Na^+ ion peaks observed by others. A second internal friction peak was observed in $\text{R}_2\text{O}\cdot\text{ROxSiO}_2$ glasses at a higher temperature than the "alkali" peaks. The gradual replacement of Na^+ by K^+ or Li^+ caused the alkali peaks to disappear and the intermediate temperature damping to become large.

405. Illinois University, Urbana, Illinois,
DISLOCATION DAMPING IN LEAD, COPPER, AND ALU-
MINUM by G. S. Baker, 1957, Ph. D. Thesis.

It was found that the curve of decrement versus strain amplitude has four regions of strain amplitude dependence: 1) an initial strain amplitude independent region at low strain amplitudes, 2) a region of strong strain amplitude dependence, 3) a second region of low-to-zero strain amplitude dependence, and 4) a final region of high strain amplitude dependence near the yield point. The presence of a static biasing stress has little effect on the damping in the first three regions of strain amplitude dependence. In the case of aluminum, the presence of a static biasing stress was shown to shift the final region of strain amplitude dependence to a lower strain amplitude.

406. Imoto, S. and Mima, G.,
INTERNAL FRICTION OF OXYGEN-CONTAINING COPPER.
I., Japanese Institute of Metals, Journal, Vol. 21, 1957,
pp. 269-271.

Internal friction and its amplitude dependence were measured with copper specimens.

407. Jaeckel, R. and Junge, H.,
MEASUREMENT OF THE EMISSION OF NITROGEN DIS-
SOLVED IN PURE IRON INTO A VACUUM, Annals of
Physics (Leipzig), Vol. 20, Nos. 1-6, 1957, pp. 331-336
(In German).

A method utilizing the dependence of the damping of elastic oscillations of iron wires on the amount of nitrogen absorbed in them, is described; the results show that at 520° C about 10^{13} nitrogen atoms/cm²/sec are given out into a vacuum of 2×10^{-5} millimeter mercury from wires given a specified treatment.

408. Kamigaki, K.,
ULTRASONIC ATTENUATION IN STEEL AND CAST IRON,
Science Report of the Research Institute, Tohoku University,
Vol. 9A, February 1957, pp. 48-77.

Pulsed longitudinal waves of 0.5 to 25 mc/sec were used on cast irons and steels with various textures. Chromium-molybdenum and carbon steel were normalized, quenched, tempered to troostite-sorbite and attenuation measured at each stage. Austenite grain size was also investigated by heat treatment above the transformation point. White cast iron was tempered in stages to spheroidal graphite structure. Flake graphite irons were also used.

409. Kê, T. S. and Chow, P. L.,
A STUDY ON THE ACOUSTIC INTERNAL FRICTION OF
IRON VIBRATING TRANSVERSELY IN A STUDY MAGNETIC
FIELD BY PIEZOELECTRIC CRYSTAL PLATES, Scientia
Sinica, Vol. 6, No. 2, 1957, pp. 237-245.

In this study, damping was measured as a function of the intensity of the magnetic field up to 150 oersteds; the damping tended toward a limiting value. The study was made using plates of Rochelle salts for 1633 cps.

410. Kê, T. S. and Chu-tszyan, T.,
ON THE ORIGIN OF PEAKS OF INTERNAL FRICTION
CONNECTED WITH THE DIFFUSION OF CARBON CAUSED
BY STRESSES IN ALLOY STEELS WITH A FACE-CENTERED
CUBIC LATTICE, Akademii Nauk, SSSR, Metallov i Metal-
lovedenie, Vol. 4, No. 2, 1957, pp. 291-305.

Internal friction peaks associated with the stress-induced diffusion of carbon were examined in manganese steels of four compositions. The maximum internal friction is observed in a temperature zone of 250° C with a frequency of vibration of about 2 cps. Experimental results show that the height of the internal friction peak is in linear relationship with the concentration of carbon in solid solution. The origin of these peaks is explained on the basis of the proposition that, in the course of alternating strain, carbon fills up the octahedral interstices of a face-centered cubic lattice. An atom of an alloying element or a hole produces with an atom of carbon an atomic pair which sets up distortion in the lattice, which differs in three crystallographic directions. The movement of these atomic pairs under stress produces internal friction.

411. Kê, T. S. and Ma, Y. L.,
INTERNAL-FRICTION PEAK ASSOCIATED WITH STRESS-
INDUCED DIFFUSION OF CARBON IN LOW -C ALLOY
MARTENSITE, Scientia Sinica, Vol. 6, 1957, pp. 81-90.

A new, internal-friction peak (I) appears at 155° when a thin bar of the material is worked with a torsion pendulum at a frequency of vibration of 2 cps. The height of I is directly proportional to the carbon content, and a preliminary model is suggested in which carbon atoms are located at the interstitial positions of the crystal matrix.

412. Kê, T. S. and Yang, P. W.,
A STUDY OF THE DIFFUSION OF CARBON IN γ - IRON BY
INTERNAL FRICTION, Scientia Sinica, Vol. 6, 1957, pp.
626-632.

At approximately 240° at a frequency of 2 cps, an internal friction was observed in γ - iron (containing 1.7 percent manganese). The peak increased with carbon content. Since the activation energy associated with the peak was 34 ± 2 kilocalories per mole, it was concluded that the

peak is associated with the stress-induced diffusion of carbon in γ -iron because of the agreement with macrodiffusion exponents. The height of the peak varies with the square of the carbon content.

413. Kê, T. S., Yung, P. T., and Chang, C. Y.,
INTERNAL FRICTION IN THE PROCESS OF PLASTIC
DEFORMATION OF METALS, Science Record, Vol. 1, No.
4, 1957, pp. 231-236.

Changes in internal friction during tensile elastic and plastic deformation and stress relaxation were measured. Materials studied were ingot iron, carbon-free iron, high-purity copper, and 99.99 percent aluminum.

414. Kê, T. S. and Ma, Y. L.,
INTERNAL-FRICTION PEAK ASSOCIATED WITH STRESS-
INDUCED DIFFUSION OF CARBON IN LOW-CARBON
ALLOY MARTENSITE, Wu Li Hsueh Pao, Vol. 13, 1957,
pp. 69-77.

An internal-friction peak was observed around 155° at 2 cps in steel specimens containing martensite, alloying element (nickel, chromium, or both), and carbon. The peak was proportional to carbon content in a 29.7 percent nickel steel and increased with nickel content from 10 to 18.6 to 29.7 percent.

415. Kessler, J. O.,
INTERNAL FRICTION AND DEFECT INTERACTION IN
GERMANIUM: EXPERIMENTAL, Physical Review, Vol.
106, 1957, pp. 646-653.

The internal-friction method has been applied to study defect impurity relations in germanium. Logarithmic decrement of crystals undergoing small-amplitude forced longitudinal vibrations was determined versus temperature, frequency, impurity concentration, and edge dislocations. For 40 kc/sec, an anelastic relaxation peak with relaxation time dependent on temperature was observed at 380° . At higher temperatures, the decrement rose with temperature.

416. Kessler, J. O.,
INTERNAL FRICTION AND DEFECT INTERACTION IN
GERMANIUM: THEORETICAL, Physical Review, Vol. 106,
1957, pp. 654-658.

A model is proposed for energy dissipation caused by stress-induced change in equilibrium distribution of mobile circumdislocation impurities which are surrounded by Cottrell atmospheres and deflect as described by Koehler.

417. Khil'chevskii, V. V.,
DETERMINATION OF THE PARAMETERS OF THE
HYSTERESIS LOOP CHARACTERIZING THE DAMPING
PROPERTIES OF A MATERIAL, Izv. Kievsk. Politekhn.
In-ta, Vol. 20, 1957, pp. 272-277.

The damping properties of metals depend on the size of the stresses which are produced in them in consequence of vibrations. These properties are taken into account by means of two parameters, one of which determines the form while the other establishes the size of the area of the hysteresis loop. An attempt is made to select these parameters in such a way that the area of the hysteresis loop remains the same for different stresses.

418. Kun, C. P. and Kê, T. S.,
INTERNAL FRICTION MAXIMUM, ASSOCIATED WITH
HYDROGEN MOLECULE DIFFUSION CAUSED BY STRESSES
IN HIGH-ALLOYED CHROMIUM-NICKEL STEELS, Akademi
Nauk, SSSR, Fizika Metallov i Metallovedenie, Vol. 5, No.
1, 1957, pp. 64-71.

A study was made of the internal friction peaks connected with the presence of hydrogen in high alloy chrome-nickel steels. The optimum temperature for the internal friction maximum lies between 610° and 640° C with an oscillation frequency of about 1.5 cps. Systematic investigations were made on test-specimens containing 18 percent chromium and 12 percent nickel. The value of the activation energy and the behavior of the internal friction when the temperature is raised, lowered or maintained constant, leads to the conclusion that this peak is associated with micro-diffusion of hydrogen molecules, brought about by stresses in high-alloyed steels.

419. Kung, C. P. and Kê, T. S.,
INTERNAL FRICTION PEAK ASSOCIATED WITH THE
STRESS-INDUCED DIFFUSION OF HYDROGEN MOLECULES
IN HIGH CHROMIUM-NICKEL ALLOY STEELS, Scientia
Sinica, Vol. 6, 1957, pp. 223-235.

Internal friction peaks associated with the presence of hydrogen in eight types of high chromium-nickel alloy steel were studied. The conclusion was reached that the new internal friction peak is associated with the stress-induced microdiffusion of hydrogen molecules in high alloy steels. Internal friction measurements also disclose the temperature range in which transformations between hydrogen moles and hydrogen atoms were occurring in 18 percent chromium-12 percent nickel alloy steel specimens for a given rate of heating and cooling.

420. Kurath, S. F., Passaglia, E., and Pariser, R.,
DYNAMIC MECHANICAL PROPERTIES OF POLYHEXENE-
1, Journal of Applied Physics, Vol. 28, No. 4, April 1957,
pp. 499-502.

A double electromagnetic transducer has been used to evaluate the complex shear modulus of polyhexene-1 from 70° to -27.5° C in the 25 to 2500 cps frequency range. Real and imaginary components of the complex shear modulus as well as the mechanical loss tangent are reported over nine decades of reduced frequency.

421. Kurge, C.,
ULTRASONIC DAMPING IN METALS AT LOW TEMPERA-
TURES IN THE NORMAL AND SUPERCONDUCTING STATES,
Naturwissenschaften, Vol. 44, 1957, pp. 368-370.

The damping of high frequency (710⁷ cosine) waves by conduction electrons was studied in copper and lead and in particular, zinc single crystals for both longitudinal and transverse waves at 2° to 15° K. A quartz crystal oscillator was used as the vibration source. Damping increases nonlinearly with frequency. The superconducting region shows the expected fall in damping. The degree of damping for the normal conductance state is strongly dependent on the purity of metal. Calculated and measured temperature dependence of damping are in good agreement.

422. Kurtze, G.,
ABSORPTION OF ULTRASONIC WAVES IN METALS AT
VERY LOW TEMPERATURES IN NORMAL AND SUPER-
CONDUCTIVE CONDITIONS, Naturwissenschaften, Vol. 44,
No. 13, 1 July 1957, pp. 368 - 370.

This article presents a method for determining velocity and phase of waves, and a theory for estimation of absorption.

423. Lazan, B. J.,
DAMPING, ELASTICITY, AND FATIGUE PROPERTIES OF
STELLITE 31 AND THEIR DESIGN SIGNIFICANCE ,
Westinghouse Purchase Contract No. 54-W-34178, April
1957.

Not abstracted.

424. Lazan, B. J. and Lidstrom, L. C.,
STRESS DISTRIBUTION UNDER CYCLIC BENDING CON-
SIDERING THE EFFECT OF FATIGUE ON STRESS-STRAIN
PROPERTIES, Actes, Ninth International Congress of
Applied Mechanics, Brussels, Vol. 8, 1957, p. 327.

The purpose of this paper is to study the changes in the stress-strain properties of a material under fatigue stress and the resultant stress redistribution which takes place during a bending fatigue test. The actual maximum stress under bending fatigue determined considering the actual non-linear stress distribution may be significantly smaller than the nominal stress. The relationship of the difference to the difference between bending and axial fatigue strength is discussed.

425. Leaderman, H.,
PROPOSED NOMENCLATURE FOR LINEAR VISCOELAS-
TIC BEHAVIOR, Society of Rheology, Transactions, Vol. 1,
1957, pp. 213-222.

This report deals with a proposed nomenclature for primary measurable quantities and for related quantities applicable to isotropic materials manifesting (approximate) linear viscoelastic behavior. The basis for the nomenclature is given, and some of the relations between the primary measurable quantities are given.

426. Lessen, M.,
THERMOELASTIC DAMPING AT THE BOUNDARY BETWEEN
DISSIMILAR SOLIDS, Journal of Applied Physics, Vol. 28,
No. 3, 1957, pp. 364-366.

The problem of thermoelastic damping at the boundary between dissimilar solids is investigated for the case of small sinusoidal, longitudinal disturbances of long-wave length propagating normally through the interface. The relevant equations are derived from thermodynamic considerations, and it is found that the mechanical energy absorption per unit time is proportional to the square root of the disturbance frequency.

427. Lücke, K. and Granato, A.,
INTERNAL FRICTION PHENOMENA DUE TO DISLOCATIONS,
Dislocations and Mechanical Properties of Crystals, New
York, New York, John Wiley and Sons, Incorporated, 1957,
pp. 425-457.

The authors carefully review several theoretical models which seem to be capable of describing at least certain aspects of the damping phenomena observed in metals. The theories are compared with the available data. The theory proposed by the authors seemed to be most satisfactory at the time the paper was written. A general survey of the damping phenomena presumably due to dislocations is given and illustrated with experimental evidence. Numerous references are cited. A discussion of the state of affairs, both theoretical and experimental, in the field concludes the paper.

428. Mackinnon, L.,
FURTHER ULTRASONIC EXPERIMENTS IN SUPER-
CONDUCTING POLYCRYSTALLINE TIN, Physical Review,
Vol. 106, No. 1, 1 April 1957, pp. 70-72.

The effect of a longitudinal magnetic field on the sound absorption in a polycrystalline tin rod below and just above the superconducting transition has been studied.

429. Maeda, Y.,
ULTRASONIC VELOCITY AND ATTENUATION IN SILICONE
RUBBERS, Kobunshi Kagaku, Vol. 14, 1957, pp. 620-623.

Ultrasonic velocity and attenuation have been measured in three kinds of silicone rubbers at frequencies of 0.71, 2.88, and 8.64 mc/sec over a temperature range of -60° to 50° C.

430. Malvern, L. E.,
EFFECT OF DAMPING ON VIBRATION FREQUENCIES OF
SIMPLE SYSTEMS, Third Midwest Conference on Solid
Mechanics, Proceedings, Ann Arbor, Michigan, University
of Michigan Press, 1957, pp. 195-205.

Not abstracted.

431. Matta, K. M.,
RELAXATION PROCESS IN BISMUTH, Mathematics and
Physics Society of Egypt, Proceedings, No. 21, May 1957,
pp. 135-146.

The velocity and the internal friction with flexural waves were measured for six different samples of bismuth at frequencies in the acoustic range and at temperatures varying from room temperature to the melting point. The velocity was found to decrease linearly with temperature while the internal friction curves have shown a peak resulting from a relaxation process in the metal.

432. Mead, D. J.,
THE EFFECT OF STRUCTURAL DAMPING UPON THE
STRESSES DUE TO JET EFFLUX, Royal Aeronautical
Society, Journal, Vol. 61, 1957, pp. 108-109.

This article investigates the effect of structural damping on the stresses due to jet efflux. Also covered are various means of increasing the structural damping.

433. Merkulov, L. G.,
ABSORPTION AND DIFFUSE SCATTERING OF ULTRA-
SOUND IN METALS, Zhurnal Tekhnicheskoi Fiziki, Vol. 27,
No. 5, 1957, pp. 1045-1050.

Measurements were made by an impulse technique on polycrystalline material in the frequency range from 5 to

180 mc/sec for two aluminum ingots (99.5 percent aluminum), two ingots of a magnesium-manganese alloy (magnesium 98.5, manganese 1.5 percent), and an iron ingot of technical purity (carbon < 0.02 percent). The grain-sizes used ranged from 0.25 to 2 millimeters. It is suggested that measurements of ultrasonic absorption might be useful in determining grain-sizes and textures.

434. Mikhailov, G. P., Kabin, S. P., and Krylova, T. A., DIELECTRIC AND MECHANICAL LOSSES OF LOW-PRESSURE POLYETHYLENE, Zhurnal Tekhnicheskoi Fiziki, Vol. 27, No. 9, 1957, pp. 2050-2055 (In Russian).

The experimental investigation of the dielectric and mechanical losses of low-pressure polyethylene revealed two ranges of maxima of tangent δ in the frequency ranges 1.5 and 10 kc/sec and in the temperature interval -110° to 120° C.

435. Mikhailov, I. G. and Solov'ev, V. A., STUDY OF MECHANICAL PROPERTIES OF POLYETHYLENE AND PARAFFIN [OIL] BY A COMPOUND VIBRATOR METHOD, Akusticheski Zhurnal, Vol. 3, No. 1, 1957, pp. 65-73.

The method and apparatus described in an earlier paper enables measurements of the velocity of longitudinal waves and of mechanical losses to be made over a wide range of temperatures. Velocity of sound versus temperature curves for both substances are given.

436. Milligan, H. L., THE EFFECT OF FREQUENCY AND PHYSICAL STRUCTURE UPON THE SOLID DAMPING PROPERTY OF MATERIALS, Unpublished Report, Bellevue, Washington, 1957.

Damping studies were conducted on a few plastics and several sheet and cast metals, in both the tempered and annealed condition. The specimens were mounted as cantilever beams to a shaker pot and accelerometers attached for instrumentation. Beam lengths were changed to obtain a range of resonant frequencies and the vibrational energy level varied to determine the relationship between damping and frequency at certain stress levels.

437. Mima, G. and Mizuta, M.,
HYDROGEN EMBRITTLEMENT AND INTERNAL FRICTION
OF CARBON STEEL, Iron and Steel Institute of Japan,
Journal, Vol. 43, 1957, pp. 132-137.

Experiments were conducted with some hypoeutectoid carbon steels (carbon 0.07-0.68 percent), pure iron, and eutectoid steel (carbon 0.85 percent). The amounts of hydrogen evolved, changes in internal friction and mechanical properties at room temperature of electrically charged hydrogen and their interrelations were investigated. A decrease in elongation and reduction of area in tensile tests, a decrease in impact value, and an increase in internal friction were caused by aging.

438. Minnesota University, Minneapolis, Minnesota,
ANALYTICAL METHODS FOR DETERMINING SPECIFIC
DAMPING ENERGY CONSIDERING STRESS DISTRIBUTION
by E. R. Podnieks and B. J. Lazan, June 1957, Report No.
OTS PB 131250, 42 pp.

Various energy and energy ratio units for expressing damping properties of materials are discussed. Specific damping energy (in-lb/cu. in/cycle) is proposed as the most useful unit for comparing materials and performing engineering calculations.

439. Minnesota University, Department of Aeronautics Library,
Minneapolis, Minnesota,
DAMPING AND FATIGUE PROPERTIES OF MANGANESE-
COPPER ALLOYS PROPOSED AS NEW HIGH DAMPING
MATERIALS, APPENDIX A by V. W. Anderson and B. J.
Lazan, 1957, Final Report on Projects 72b and 72c.

In this investigation, the room temperature damping and fatigue properties were determined by rotating beam methods for two alloys proposed as high damping materials. One was a magnesium alloy furnished by the Bureau of Mines. Data on the damping and fatigue properties of these two materials are presented and discussed in terms of the important test variables.

440. Minnesota University, Department of Aeronautics Library, Minneapolis, Minnesota,
DAMPING PROPERTIES OF SOME MAGNESIUM BASE, ALUMINUM BASE, AND FERROUS ALLOYS by W. J. Trapp, 1957, 14 pp.

Damping tests were conducted on 15 magnesium alloys, 7 aluminum alloys, and 4 ferrous alloys using flat cantilever specimens stressed in bending. The mean specific damping capacity of a magnesium alloy was higher than the aluminum and ferrous alloys except for cast iron. The highest values of mean specific damping capacity were obtained for the as-cast magnesium alloys. Heat treating and machining have a detrimental effect on the damping capacity of cast alloys. Annealing is beneficial for sheet alloys.

441. Minnesota University, Minneapolis, Minnesota,
INTERRELATION OF FATIGUE CRACKING, DAMPING, AND NOTCH SENSITIVITY by L. J. Demer, March, 1957, Report No. OTS PB 131025, 164 pp.

This report presents the results of numerous fatigue tests performed on a variety of metallic materials in which observations were made of the changes in damping and stiffness properties of the specimens and of the development of fatigue macrocracks.

442. Mišek, K.,
ON THE ORIGIN OF THE MAGNETOMECHANICAL PHENOMENON IN AN ALTERNATING FIELD, Czechoslovak Journal of Physics, Vol. 1, 1957, pp. 247-248.

Author concludes that macroscopic eddy currents, caused by irreversible displacements of Bloch walls, cannot be the essential cause of the observed maximum.

443. Missouri University, School of Mines and Metallurgy, Rolla, Missouri,
INTERNAL FRICTION IN MANGANESE-COPPER ALLOYS by W. P. Dixon, 1957, 45 pp.

The dependence of internal friction in manganese-copper alloys on temperature was measured with a Kê-type pendulum at low frequencies. The temperature range used in the tests was from -30° to 250° C.

444. Mizuta, M.,
EFFECTS OF STRUCTURES ON THE CHANGES OF INTERNAL FRICTION OF SOME STEELS CAUSED BY ABSORBED HYDROGEN, Iron and Steel Institute of Japan, Journal, Vol. 43, 1957, pp. 1057-1059.

Damping as a function of aging time was studied in carbon steels (0.37, 0.68, and 0.84 carbon), in a nickel-chromium steel (0.74 chromium, 1.85 nickel) and in a nickel-copper-molybdenum steel (0.54 chromium, 1.92 nickel, unspecified molybdenum).

445. Muller, H. L.,
FLEXURAL WAVE DAMPING BY SYMMETRIC AND ECCENTRIC LOADING, Frequenz, Vol. 11, No. 1, October 1957, pp. 325-330, No. 11, November 1957, pp. 342-351.

The author deals theoretically with the cases in which the load is attached symmetrically (equally on opposite sides of the vibrating rod or strip) and eccentrically (on one side only). Comparative curves are shown illustrating the relative damping effects of a single mass and of a number of separated masses.

446. Nakamura, K. and Okawa, T.,
VISCOELASTICITY OF CELLULOSE DERIVATIVE FILMS. III. SECOND-ORDER TRANSITION POINTS OF CELLULOSE NITRATES, Kobunshi Kagaku, Vol. 14, 1957, pp. 544-550.

Dynamic Young's moduli and internal friction of three cellulose nitrates are measured. At least two dispersion regions are observed for each sample. The transition temperature observed by dilatometry decreases with the increase of percent nitrogen which does not agree with the dynamic results.

447. National Advisory Committee for Aeronautics,
A STUDY OF THE RESPONSE OF PANELS TO RANDOM ACOUSTIC EXCITATION by R. W. Hess, L. W. Lassiter, and H. H. Hubbard, 1957, Report No. RM L55E13c.

An application is made of the method of generalized harmonic analysis to the problem of prediction of stresses in airplane-skin panels due to excitation by jet noise. The concepts of the theory are reviewed briefly, and some of the

significant parameters are evaluated in the tests. Measurements of stresses in some panels due to random acoustic excitation are presented and are found to be in general agreement with calculated results.

448. National Advisory Committee for Aeronautics,
CALCULATED AND MEASURED STRESSES IN SIMPLE
PANELS SUBJECT TO INTENSE RANDOM ACOUSTIC
LOADING INCLUDING THE NEAR NOISE FIELD OF A
TURBOJET ENGINE by L. W. Lassiter and R. W. Hess,
September 1957, TN 4076.

Flat 2024-Te aluminum panels were tested in the near noise fields of a four-inch air jet and turbojet engine. The stresses which were developed in the panels are compared with those calculated by generalized harmonic analysis. The calculated and measured stresses were found to be in good agreement. To make the stress calculations, supplementary data relating to the transfer characteristics, damping, and static response of flat and curved panels under periodic loading were necessary and were determined experimentally.

449. National Advisory Committee for Aeronautics,
INVESTIGATION OF SOME MECHANICAL PROPERTIES OF
THERMENOL COMPRESSOR BLADES by D. F. Johnson,
1957, Report No. TN 4097.

A series of tests were made comparing the mechanical properties of similar compressor blades of AISI type 403 stainless steel and thermenol. Eighth-stage J47 and J65 compressor blades of each material were tested. The thermenol blades had a logarithmic decrement of damping of 3.35 percent compared with 4.9 percent for stainless steel. The damping measurements were made using the resonant peak method at stresses close to the fatigue limit of the materials.

450. Neppiras, E. A.,
METAL FATIGUE AT HIGH FREQUENCY, Physical Society,
London, Proceedings, Vol. 70, Section B, Part 4, 1957,
pp. 393-401.

Metal samples were subjected to tension-compression stresses above the fatigue limit at frequencies around 18 kc/sec, produced by a resonant magnet-obstruction transducer.

The work showed that the high-frequency technique possesses a number of advantages over conventional methods of fatigue analysis. But the measurements confirm that at this frequency the fatigue limit is appreciably higher than that obtained from low-frequency measurements. This frequency effect would complicate the design of a practical accelerated testing machine.

451. Niblett, D. H. and Wilks, J.,
THE INTERNAL FRICTION OF COLD-WORKED COPPER
AT LOW TEMPERATURES, Philosophical Magazine, Vol.
2, Series 8, December 1957, pp, 1427-1444.

The internal friction was measured in the temperature range 20° to 300° K, and a study made of the maximum in the curve of internal friction versus temperature first observed by Bordoni. The measurements indicate how the internal friction varies as a function of the amount of cold work, and, also, the effects of impurities in the metal and of neutron irradiation.

452. Nowick, A. S.,
RECOVERY OF INTERNAL FRICTION AND ELASTIC CON-
STANTS; CREEP AND RECOVERY, American Society for
Metals, Transactions Quarterly, 1957, pp. 146-175.

Recovery following plastic deformation is customarily regarded as a thermally activated process of redistribution and annihilation of dislocations and of point defects produced by plastic flow. It is shown herein that the internal friction and elastic constants, as measured dynamically, are particularly well-suited to the study of such phenomena.

453. Nuclear Metals, Incorporated,
INTERNAL FRICTION OF EXTRUDED BERYLLIUM by A.
Boltax, Report No. NMI-1170; USAEC Annual Program
Report for Period Ending 30 June 1956 (Metallurgy and
Ceramics), 18 February 1957.

This report describes specimen preparation and equipment.

454. Office of Naval Research, Undersea Warfare Branch,
A PRELIMINARY INVESTIGATION OF SOME BLANKET
DAMPING TREATMENT VARIABLES by S. S. Kushner and
J. C. Johnson, 1957, 20 pp.

An investigation of the dependence of vibration-damping capacity on frequency, septum seight, blanket density, and blanket thickness was carried out by means of the thick-plate decay rate apparatus for several fibrous-glass-blanket septum configurations, and correlations between these parameters were demonstrated.

455. Ohio State University, Columbus, Ohio,
INVESTIGATION OF THE RELATIONSHIP BETWEEN
THREE-DIMENSIONAL CYCLIC STRAIN AND HEAT GEN-
ERATION IN RUBBER-LINE MATERIAL by F. S. Tse,
1957, 282 pp., Thesis (Dissertation Abstracts, Vol. 17,
1957, p. 1528).

The relation between three-dimensional cyclic strain and hysteresis heat in rubber was investigated to establish a rational basis for relating hysteresis and different types of strain.

456. Parfitt, G. G.,
DAMPING IN THE RIGID HIGH POLYMERS, Ninth Interna-
tional Congress of Applied Mechanics, University of Brussels,
Vol. 5, 1957, pp. 360 - 367.

A theory of mechanical damping in a high polymer in the rigid or glassy state is proposed, based on the concept of mechanical relaxation occurring in small regions of lower packing density within the structure. The results reproduce qualitatively many features of the observed dependence of damping on frequency, temperature and volume.

457. Pavlov, V. A., Kryuchkov, N. F., and Fedotov, I. D.,
NEW INTERNAL FRICTION PEAKS AT LOW TEMPERA-
TURES, Akademii Nauk, SSSR, Fizika Metallov i Metal-
lovedenie, Vol. 5, No. 2, 1957, pp. 371-372.

Pure aluminum and an aluminum-magnesium alloy (3 percent magnesium) were studied. Two internal friction peaks were observed in the following temperature ranges: room temperature to liquid nitrogen; -50° to -90° ; -170° to -180° C.

458. Pelzer, H.,
MODELS OF MATERIALS WITH LOSS PER CYCLE NEARLY
INDEPENDENT OF FREQUENCY, Journal of Polymer
Science, Vol. 25, 1957, pp. 51-60.

Based on a continued fraction expansion of the logarithmic function, ladder-type structures are constructed which exhibit, either approximately or over a limited range of frequencies, a loss behavior that is often encountered in high polymers not only in the dielectric behavior but also in rheology, that is, a loss per cycle that is independent of frequency down to extremely low frequencies. Although such formal models have in general no direct bearing on the actual mechanism, in the present case one of them seems to suggest a molecular model in which groups of molecules are cross-linked into spindle-shaped aggregates and immersed in the viscous liquid constituted by the remaining molecules.

459. Pennsylvania State University,
DYNAMIC MECHANICAL PROPERTIES OF IRRADIATED
POLYETHYLENE AND NYLON by C. W. Deeley, 1957,
78 pp., Thesis (Dissertation Abstracts, Vol. 18, 1958, p.
259).

The dynamic mechanical properties, namely, internal friction and dynamic modulus, have been used in the study of the molecular motions occurring in polyethylene and polyhexamethylene adipamide (nylon 6-6). Each polymer is characterized by a unique internal friction versus temperature spectrum showing one or more peaks reflecting the onset of mobility of various structural elements in the long chain molecule.

460. Pian, T. H. H.,
STRUCTURAL DAMPING OF A SIMPLE BUILT-UP BEAM
WITH RIVETED JOINTS IN BENDING, Journal of Applied
Mechanics, Vol. 24, March 1957, pp. 35-38.

A theoretical study is made of the structural damping of a simple built-up beam with thin reinforcing spar caps in which the rivets or screws prevent sliding motion between the cap and the beam. An analytical expression of the energy lost per cycle of static loading is derived in terms of

amplitude of load, stiffness of rivets, and tightness of joint. Experimental measurements on a test beam provide a qualitative verification of the theory.

461. Pigusov, Y. V.,
STUDY OF THE INTERNAL FRICTION IN GAMMA AND ALPHA-PHASES OF HIGH-CHROMIUM STEELS, Doklady Akademii Nauk SSSR, Vol. 112, No. 4, 1957, pp. 636-639.

Specially melted steel 105 Kh 12 containing 1.05 percent carbon, 11.9 percent chromium, and 0.012 percent nitrogen is investigated. On curves are data on correlating temperature and on internal friction of specimens quenched from 800° to 1020° C at a frequency of 1.4 cps.

462. Pippard, A. B.,
A PROPOSAL FOR DETERMINING THE FERMI SURFACE BY MAGNETO-ACOUSTIC RESONANCE, Philosophical Magazine, Vol. 2, Series 8, No. 21, September 1957, pp. 1147-1149.

It has been observed that attenuation of ultrasonic waves in a pure tin crystal at 4° K is affected by a transverse magnetic field in a manner which is periodic with the field strength. The probable origin of the effect may be understood by considering a free-electron model of a metal, carrying transverse ultrasonic waves of wavelength short compared with the electronic free path.

463. Plass, H. J., Jr.,
DAMPING VIBRATIONS IN RODS AND SANDWICH STRUCTURES BY INCORPORATION OF ADDITIONAL VISCO-ELASTIC MATERIAL, Third Midwest Conference on Solid Mechanics, Proceedings, University of Michigan Press, 1957, pp. 48-71.

Not abstracted.

464. Pluhar, J.,
DEVELOPMENT AND TESTING OF HIGH TEMPERATURE ALLOYS IN CZECHOSLOVAKIA, Archiv für das Eisenhüttenwesen, Vol. 28, 1957, p. 207.

A brief review of some work being carried out on some ferritic and austenitic steels is presented.

465. Postnikov, V. S.,
INTERNAL FRICTION OF SOME PURE METALS AS A
FUNCTION OF TEMPERATURE, Akademii Nauk, SSSR,
Fizika Metallov i Metallovedenie, Vol. 4, 1957, pp. 344-351.

Internal friction of aluminum, copper, nickel, cobalt, iron, titanium, molybdenum, and tungsten was determined. By using torsional deformation below 10^{-5} and temperatures up to 720° . The diagrams show that annealed specimens have a constant and reproducible temperature effect on internal friction, and each polycrystalline metal has at least one maximum or inflection point. The maximum of internal friction lies in the recrystalline zone of the metal and depends on the previous cold deformation. Higher-melting metals have a lower level of internal friction at a given temperature than metals melting at lower temperature.

466. Powers, R. W. and Doyle, M. V.,
CARBON TANTALUM INTERNAL FRICTION PEAK, Journal
of Applied Physics, Vol. 28, 1957, pp. 255-258.

The internal friction peak in tantalum arising from the diffusion of interstitial carbon has been located at 338° for vibration frequencies of 0.55 cps. The identification of this peak is made difficult by its proximity to the nitrogen peak. However, the two can be distinguished by the lesser stability of the carbon peak with respect to aging at 400° and by a different dependence of peak height on solute concentration.

467. Powers, R. W. and Doyle, M. V.,
INTERNAL FRICTION STUDIES IN NIOBIUM, Journal of
Metals, Vol. 9; American Institute of Mining, Metallurgical,
and Petroleum Engineers (AIME), Transactions, Vol. 209,
1957, pp. 1285-1288.

Carbon has been found to diffuse in niobium at a greater rate than nitrogen. At 1 cps, that internal friction peak, which arises from the stress-induced ordering of carbon in niobium, is found at 268° while the nitrogen peak occurs at 285° . The carbon peak in niobium is very unstable, the height declining rapidly with time in contrast to the nitrogen peak. The internal friction in high-purity niobium was found to be a sensitive function of the strain amplitude at which the damping was measured.

468. Raskovic, D. ,
TRANSVERSE VIBRATIONS OF A TRIANGULAR PLATE
WITH DAMPING, Ninth International Congress of Applied
Mechanics, University of Brussels, Vol. 7, 1957, pp. 478-
484.

Small transverse vibrations of a homogeneous and isotropic triangular plate built-in at one end and free at the other are considered when damping proportional to the velocity is acting. After removal of the damping term by a standard transformation, the method of Galerkin is used to find the natural frequencies.

469. Rawlings, R. ,
INTERNAL FRICTION OF Al-Mg-Fn ALLOYS, Institute of
Metals, Bulletin, Vol. 3, 1957, p. 180.

This short letter describes a damping peak obtained on the alloy after quenching from 470° C and aging.

470. Roswell, A. E. and Nowick, A. S. ,
QUENCH HARDENING OF PURE GOLD AS OBSERVED BY
INTERNAL FRICTION METHODS, Acta Metallurgica, Vol.
5, 1957, pp. 228-235.

Specimens of 99.999 percent gold were cut from a 0.25-inch square bar and tested in a three-part composite piezoelectric resonator. A quench-hardening effect was observed, similar to that found in zinc and aluminum. The difference between quenched and furnace-cooled specimens was observed to anneal out in the range 160° to 200°. These phenomena reinterpreted in terms of the pinning of dislocations by attached vacancies.

471. Rothenstein, B. and Hrinca, J. ,
INTERNAL FRICTION, A USEFUL PHYSICAL MAGNITUDE
IN METALLURGY, Mei. Constr. Masini, No. 11, 1957,
pp. 8-12.

After defining some necessary values used in its determination the methods of measuring internal friction are given: the torsion pendulum, the electrostatic, the piezoelectric, the Foucault currents and the electromagnetic methods, followed by a theoretical explanation of internal friction.

472. Rozanski, W. and Madej, S.,
INFLUENCE OF STEEL MICROSTRUCTURE UPON SUP-
PRESSION OF ULTRASONIC WAVES, Hutnické Listy, Vol.
24, November 1957, pp. 452-457.

This article investigates damping of ultrasonic waves in solid bodies, and explores the relationship between damping coefficient and microstructure of the medium transferring wave motion. Results of investigation of ultrasonic wave damping in annealed carbon steels are given.

473. Rusanova, E. I.,
DISCONTINUOUS VIBRATIONS OF THE BLADES IN AXIAL
COMPRESSORS, Sudostroyeniye, No. 10, 1957, pp. 21-24.

The dynamic stresses were measured in the basal sections of the working blades of the first three stages of an axial compressor. Vibration is attributed to disruptive flutter which takes place at large angles of attack. Formulas are put forward, with no previous deduction, which take into account the irregularity of the flow and the damping action in the blade material.

474. Schilling, W. and Haspel, R.,
INFLUENCE OF RECRYSTALLIZATION ON DAMPING AND
SHEAR MODULUS OF TUNGSTEN WIRES, Zeitschrift für
Metallkunde, Vol. 48, Left 1, January 1957, pp. 32-34.

Elastic damping and shear modulus are measured on drawn tungsten wires with additions of alkali silicates and thorium dioxide as a function of temperature. Rapid changes show up with secondary recrystallization which is prevented by the thorium dioxide.

475. Seeger, A., Donth, H., and Pfaff, F.,
THE MECHANISM OF LOW-TEMPERATURE RELAXATION
IN DEFORMED CRYSTALS, Faraday Society, Discussions,
No. 23, 1957, p. 19.

The three types of mechanisms by which dislocations cause energy losses in crystals - hysteresis, resonance, and relaxation - are discussed. Particular attention is paid to the experimental evidence for the relaxation mechanism. A qualitative description is presented of the mechanism for the "Bordoni" relaxation peak, which is thought to be due to

dislocations overcoming the Peierls stress by thermally activated kink formation. The results of detailed calculations on the rate and activation energy of such a process are also reported. The treatment does not employ the conventional Arrhenius equation, but derives the relaxation time from the theory of stochastic processes. It takes explicit account of the thermal stresses and the radiation losses governing the dislocation movement. The theory is compared with experimental results on metals and with dielectric measurements on quartz.

476. Seemann, H. J., Siol, M., and Detemple, E.,
EFFECT OF STATIC TENSILE STRESS ON THE DAMPING CAPACITY AND AGING OF ALPHA IRON, Annales Universitatis Saraviensis, Naturwissenschaften, Vol. 6, 1957, pp. 300-399.

In the study of the behavior of carbon and nitrogen in supersaturated alpha-iron, it is interesting to know whether a static tensile stress has any effect on aging. In most samples, a slight inhibition of aging was found. This is attributed to a disturbance in the distribution of the dislocation lines by the imposed stress. It was also found that aging is faster the higher the degree of supersaturation.

477. Singh, H.,
MECHANICAL PROPERTIES OF RUBBER-LIKE POLYMERS AT HIGH PRESSURES AT ULTRASONIC FREQUENCIES, High Polymers Symposium and Exhibition, Poona, India, 1957, p. 26.

The pulse technique has been used for the measurement of velocity and attenuation of ultrasonic waves in polyisobutylene and Hycar OR-15 at zero to 80° C and up to 21,000 psi.

478. Smialowski, M. and Droz, W.,
STUDY OF INTERCRYSTALLINE CORROSION OF STAINLESS STEEL (18/8) BY OBSERVATION OF INTERNAL FRICTION, Corrosion et Anticorrosion, Vol. 5, 1957, pp. 394-397.

Samples of 18/8 wire of 0.75 millimeter in diameter, submitted to appropriate heat treatment inducing susceptibility to intercrystalline corrosion, were maintained in boiling $\text{CuSO}_4 + \text{H}_2\text{SO}_4$ or 65 percent HNO_3 for various periods of time (up to 60 hours). The effect of corrosion

was studied by measuring the period of oscillations by the Kê method and by measuring the tensile strength. The measurement of internal friction does not present any special advantage for the study of corrosion.

479. Southgate, P. D.,
INTERNAL FRICTION OF SINGLE CRYSTAL SILICON
FROM 25 TO 1100 C, British Physical Society, Proceedings,
Vol. 70, Part 8, August 1957, pp. 804-806.

Measurements were made at 100 kc/sec. When the logarithmic decrement was plotted against the inverse of the absolute temperature, two maxima were seen--at 650° C and 1020° C. Prestraining by twisting the specimen through 13 at 1000° C initially raised the higher temperature peak and widened the 650° C but these effects were removed by annealing at 1100° C for two days.

480. Sysdev, V. I.,
A PENDULUM DAMPING DEVICE FOR VIBRATION OF
INSTALLATIONS OF A TOWER TYPE (INVESTIGATIONS
ON THE DYNAMICS OF CONSTRUCTION), Moscow, Gos.
Izd-vo Lit. Po Str-vu i Arkhitekt, 1957, pp. 61-82.

An experimental and theoretical investigation is conducted on a pendulum extinguisher, a model of which consists of a ball rolling in a groove fixed to the model of the tower. The damping of the vibrations of the model or of the actual tower is effected by the impact of the ball or of the pendulum on the model or the construction. The vibration recording of the time model was carried out by means of a Geiger vibrograph fitted with a test rod; of the actual construction with a vibrograph as above with the use of the seismic principle.

481. Takahashi, S.,
EFFECT OF CONCENTRATION OF SOLUTE ATOMS ON
INTERNAL FRICTION AND DYNAMIC YIELD POINT OF
ALPHA-COPPER ALLOYS. I, Japanese Institute of Metals,
Journal, Vol. 21, 1957, pp. 190-194.

The stress dependence of the internal friction and Young's modulus of cold-rolled and low-temperature annealed specimens of alpha-copper alloys (mainly copper-zinc alloys with zinc 30 to 36.8 percent and phosphorus 0.07 percent) were investigated at one kilocycle at room

temperature. There were two kinds of critical stresses. The first was a critical stress beyond which a marked increase of the internal friction and a marked decrease of the Young's modulus began to occur simultaneously. The other was the critical stress beyond which the internal friction and Young's modulus did not change reversibly with the stress applied.

482. Takahashi, S. and Hiroshi, K.,
THE INTERNAL FRICTION OF COPPER-ALUMINUM
ALLOYS, Science Review of Mining Metals, Japan, Vol. 1,
1957, p. 58 (Japanese Institute of Metals, Journal, Vol. 19,
1955, pp. 600-604).

The internal friction and the Young's modulus of copper-aluminum alloys with zero to 16 percent by weight aluminum were measured at room temperature by using free transversal vibration of about 1000 cps.

483. Takaoki, A.,
ATTENUATION OF ULTRASONIC WAVES IN Ni-Mo-V
STEEL WITH VARIOUS STRUCTURES, Japanese Institute
of Metals, Journal, Vol. 21, 1957, pp. 14-18.

The attenuation of ultrasonic waves in 3 percent nickel-molybdenum-vanadium steel (carbon 0.30, nickel 3.80, chromium 0.19, molybdenum 0.44, vanadium 0.14 percent) with different structures was measured by multiple echoes in steel by using a water buffer between the specimen and the transducer. All specimens were heat-treated by isothermal transformation at 600°, various austenizing, and modified austemperings.

484. Tamhankar, R., Boulanger, C., Constant, A., Plateau, J.,
Rossard, C., and Crussard, C.,
DETERMINATION OF THE HEAT OF ACTIVATION DURING
THE HOT DEFORMATION OF A STABLE AUSTENITE AND
A MILD STEEL, Comptes Rendus, Vol. 245, 1957, pp. 1242-
1244.

Based on tests of creep (550° to 800°), torsion (1000° to 1200°), and internal friction (up to the melting point), heats of activation are determined for the hot deformation of an austenite (I), carbon 0.03, nickel 36, chromium 10, and a mild steel (II), carbon 0.003 percent.

485. Thomas, A. M.,
EFFECT OF CHANGE IN TEMPERATURE ON THE TOR-
SIONAL ENERGY LOSSES IN SOME POLYAMIDES, Nature,
Vol. 179, 1957, p. 862.

The mechanical energy losses were determined for dry polyamide fibers by the damping of low-frequency free torsional vibrations from 20° to 130°. Drawing out the fibers results in a shift of the maximum energy loss to a higher temperature. Moisture lowers this temperature.

486. Thompson, D. O., Blewitt, T. H., and Holmes, D. K.,
LOW-TEMPERATURE MEASUREMENTS OF THE YOUNG'S
MODULUS AND INTERNAL FRICTION OF COPPER DUR-
ING IRRADIATION, Journal of Applied Physics, Vol. 28,
1957, pp. 742-743.

The data presented may be evidence for interstitial motion at a temperature of about 21° K in which the interstitialcy reaches a dislocation as a trapping site.

487. Thompson, D. O. and Holmes, D. K.,
EFFECT OF γ -IRRADIATION ON THE YOUNG'S MODULUS
OF COPPER, Physics and Chemistry of Solids, Vol. 1, 1957,
pp. 275-278.

Copper single crystals were subjected to irradiation with 1.2-m. e. v. Co^{60} γ - rays at room temperature. An increase in the Young's modulus and a decrease in the internal friction was noted. The effects were consistent with an interpretation based on the pinning of dislocation lines by lattice defects.

488. Truell, R. and Hikata, A.,
FATIGUE AND ULTRASONIC ATTENUATION, Symposium
on Nondestructive Testing, American Society for Testing
Materials STP, No. 213, 1957, pp. 63-70.

This paper investigates attenuation as a function of the number of cycles in tension or in tension and compression. Results of these measurements in 2S, 24ST-4, and 75S aluminum are presented.

489. United States Rubber Company,
MANUFACTURE OF RUBBER ADDUCTS AND PRODUCTS
RESULTING THEREFROM, B. P. 765833; applied 2 June
1954; filed 29 March 1955; published 16 January 1957.

Rubbery adducts are prepared by reacting Butyl rubber with maleic anhydride at 135° to 200° C in the presence of an organic compound. Data are quoted in the specification on the physical properties of the adducts formed. In particular, they have torsional hysteresis values which vary only slightly with temperature.

490. Van Itterbeek, A. ,
MEASUREMENTS WITH ORDINARY SOUND AND ULTRA-
SONICS CARRIED OUT IN THE PHYSICAL LABORATORY
OF THE UNIVERSITY OF LOUVAIN, Acoustical Society
of America, Journal, Vol. 29, No. 5, May 1957, pp. 584-
587.

This article presents brief resumes of some of the acoustical research carried on at the University of Louvain during the year 1955-1956, and descriptions of apparatus and methods, and some interpretation of the results are given.

491. Vedeneeva, M. A. ,
DETERMINATION OF INTERGRANULAR CORROSION BY
MEASURING THE INTERNAL FRICTION, Zavodskaya
Laboratoriya, Vol. 23, No.1, 1957, pp. 64-67.

Design and operation of a device developed for measuring the internal friction in steel is discussed. Eighteen percent chromium, 9 percent nickel steels with 0.08 to 0.12 percent carbon and, in one case, with 0.65 percent titanium were used in the study. Suitability of internal friction as an index of intergranular corrosion is discussed.

492. Verdini, L. ,
VELOCITY OF ELASTIC WAVES AND INTERNAL FRIC-
TION IN POLYMETHYL METHACRYLATE, Nuovo Cimento,
Vol. 5, 1957, pp. 648-658.

The results confirm the existence of a transition that is revealed by a discontinuity in the temperature coefficient of the velocity and internal friction. The transition

temperature varies with annealing between 52° and 63°. Below the transition, the internal friction increases exponentially with temperature as in pure metals. This is attributed to the breaking away of dislocations.

493. Vodsedalek, J.,
DAMPING CAPACITY OF STEELS USED FOR TURBINE
BLADES, Mechanik, Vol. 30, 1957, p. 219.

Not abstracted.

494. Wadsworth, N. J.,
ENERGY DISSIPATION DURING FATIGUE TESTS, Disloca-
tions and Mechanical Properties of Crystals, New York,
New York, John Wiley and Sons, Incorporated, 1957, pp. 479-
491.

This paper describes some measurements made on the changes in the rate of dissipation of energy during the fatigue testing of various pure metals. The specimens were rigidly fastened at one end and excited axially by an electromagnetic shaker at the other end. Aluminum, cadmium, copper and silver crystals were tested. If the specimen was soft initially, the hysteretic loop was large at the start of the test and narrowed rapidly. If the stress was below the endurance limit, little further change took place. Above this limit, the rate of energy dissipation increased steadily during the test.

495. Wasilik, J. H.,
ANISOTROPIC RELAXATION PEAK IN THE INTERNAL
FRICTION OF CRYSTALLINE QUARTZ, Physical Review,
Vol. 105, No. 4, February 1957, pp. 1174-1180.

The height of the loss peak increases by a factor of 2.1 between a sample stressed in the Y direction and one stressed in a direction -18.5 degrees from the Y axis. The shape of the observed relaxation peaks can be fitted by a theory of Zener for a relaxation of a preferred distribution of impurities induced by stress.

496. Weertman, J. ,
DISLOCATION DAMPING AT HIGH TEMPERATURES,
Journal of Applied Physics, Vol. 28, February 1957, pp. 193-
196.

An extension of an unpinned dislocation damping model into the high-temperature range is discussed. The model, which is based on the Mott-Nabarro solution-hardening theory, was previously used to explain internal friction at room temperature. With the model, it is possible to explain the high-temperature internal friction which has been observed in the kilocycle frequency range for measurements made at very low strain amplitudes. In addition, the damping due to dislocation climb is considered.

497. Weiner, L. C. and Gensamer, M. ,
EFFECTS OF AGING AND STRAINING ON THE INTERNAL
FRICTION OF HYDROGEN-CHARGED 1020 STEEL AT LOW
TEMPERATURES, Acta Metallurgica, Vol. 5, 1957, pp. 692-
694.

Aging at room temperature or previous training of hydrogen-charged 1020 steel causes an internal friction peak at 105° K to appear, reach a maximum, decrease, and finally disappear. This peak is explained by a model which involves the dragging along of hydrogen atom by oscillating dislocations. In addition, another peak at 50° K was observed which is apparently due to stress-induced diffusion of interstitial hydrogen.

498. Weinig, S. and Machlin, E. S. ,
INVESTIGATION OF THE EFFECTS OF SOLUTES ON THE
GRAIN BOUNDARY STRESS RELAXATION PHENOMENON,
Journal of Metals, Vol. 9, January 1957, pp. 32-41.

Investigation was carried out on copper binary alloys with nickel, silicon, aluminum, and silver comprising the range 0.03 to 1 percent by atomic weight solute. Two stress relaxation peaks of grain boundary origin were ascertained and studied.

499. Weinreich, G.,
ULTRASONIC ATTENUATION BY FREE CARRIERS IN
GERMANIUM, Physical Review, Vol. 107, No. 1, 1 July
1957, pp. 317-318.

The attenuation per unit length is given by encE/S
(e = electronic charge, n = carrier density, c = wave velocity, E = acousto-electric field, S = power density of the wave) and is of order $10^{-21} n/\lambda$ at liquid-air temperature and 60 mc/sec ($\lambda/2\pi$ = acoustic wavelength).

500. Wepner, W.,
MEASUREMENTS OF INTERNAL FRICTION ON SLIGHTLY
STRAINED LOW-CARBON ALLOYS, Acta Metallurgica,
Vol. 5, 1957, pp. 703-710.

The time dependence of precipitation was investigated in a specimen of pure iron to which less than 0.02 percent carbon was added, with or without previous slight deformation up to 5 percent strain. The undeformed specimen showed the well-known time law of the precipitation of carbide, the specimen strained 5 percent followed Cottrell's relation for the movement of carbon to dislocations.

501. Wever, F. and Wepner, W.,
DAMPING MEASUREMENTS ON WEAKLY STRETCHED
IRON-CARBON ALLOYS, Forsch. Wirts. Nordrhein-
Westfalen, No. 457, 1957, p. 22.

Carbide precipitation from iron with less than 0.02 percent carbon after straining is examined.

502. Wilde, R. F. and Grant, N. J.,
DYNAMIC ELASTIC MODULUS VALUES AT HIGH TEM-
PERATURES FOR NICKEL-BASE, ALUMINUM-BASE AND
METAL-METAL OXIDE ALLOYS, American Society for
Testing Materials, Proceedings, Vol. 57, 1957, pp. 917-928.

By using the dynamic method, elastic moduli were determined of: 1) nickel-base alloys, 2) Type 316 stainless steels, 3) aluminum and aluminum binary alloys, and 4) sintered and extended alloys of copper with aluminum oxide.

503. Yakovlev, I. A., Velichkina, T. S., and Baranskii, K. N.,
SOUND ABSORPTION ON PHASE TRANSITION IN ROCHELLE
SALT, Zhurnal Eksperimental'noi i Teoreticheskoi Fiziki,
Vol. 32, No. 4, 1957, pp. 935-936 (In Russian).

Ultrasonic pulses of frequency 5 mc/sec and polarized along the y-axis were propagated along the z-axis of a Rochelle salt plate. The sound absorption coefficient was measured as a function of temperature and found to be a maximum near the upper Curie point.

504. Yamada, Y.,
ON THE VIBRATIONAL DAMPING OF STRUCTURAL STEEL
BEAMS, Memoirs of the Faculty of Engineering, Kyoto
University, Vol. 19, No. 1, April 1957, pp. 1-13.

Experimental results and their consideration on the vibrational damping characteristics of model beams, and of actual steel highway bridges. The fundamental characteristics of model beams, and of actual steel highway bridges. The fundamental characteristics of damping due to internal frictions of the steel beam and the friction of bearing are clarified by using three kinds of beams.

505. Yamamoto, K. and Wada, Y.,
INVESTIGATION OF THE DYNAMIC MECHANICAL PROP-
ERTIES OF GLASSY POLYMERS BY THE COMPOSITE
OSCILLATOR METHOD, Physical Society of Japan, Journal,
Vol. 12, No. 4, April 1957, pp. 374-378.

The dynamic Young's modulus and loss factor were determined by the composite oscillator method for several glassy polymers (phenol resin, polymethyl methacrylate, polystyrene, Nylon-6 and polyester) in the temperature range of -70° to 90° C at frequencies of 50, 100, and 200 kc/sec.

506. Yung, P. T. and Kê, T. S.,
THE INVESTIGATION OF THE INTERNAL ADSORPTION
OF CARBON IN ALPHA-IRON BY THE METHOD OF
INTERNAL FRICTION, Akademii Nauk, SSSR, Fizika Metal-
lov i Metallovedenie, Vol. 4, 1957, pp. 407-416.

Iron was carburized and decarbonized, and the internal friction was measured. As the carbon diffuses, the curves

obtained show great differences, from which the state of the adsorption of the carbon at the intercrystalline zones can be derived.

507. Zboralski, D.,
SOLID-BORNE SOUND COMPONENTS AND BY-PASS COMPONENTS IN VEHICLE NOISE: A CONTRIBUTION TOWARDS THE IMPROVEMENT OF SOUND INSULATION, Glaser's Annalen, Vol. 8, 1957, pp. 246-258.

The acoustical source of sound in vehicle noise lies within the vehicle (propulsion motor) or occurs outside (rolling noise). This excitation noise migrates in the form of airborne and solid-borne sound through the vehicle panels into the passenger compartment. It is important to know the magnitudes of these individual sound components in order to plan effective noise control. Fibrous substances have proved particularly suitable for reducing and absorbing the airborne sound component. Reduction of solid-borne sound succeeds desirably by means of anti-drumming coatings, which must exhibit great internal friction with the greatest possible rigidity.

508. Zehler, V.,
THE DAMPING OF FERROMAGNETIC RESONANCE ON NICKEL-IRON WIRES, Zeitschrift Naturforschung, Vol. 12a, 1957, pp. 437-440.

Measurements are carried out on iron-nickel wires (68.75 percent nickel) to investigate the cause of the damping of the ferromagnetic resonance. The wires are stressed for a short period and plastic flow occurs. The dispersion curves are flattened, and it is impossible to approximate them by calculated curve. It is shown that this flattening does not come from inner tensions in the wire but from discontinuities and cracks in the wire's surface.

509. Ziembra, S.,
THE INFLUENCE OF MASS AND INTERNAL FRICTION ON FREE TORSIONAL VIBRATIONS OF A BAR, Archiwum Mechaniki Stosowanej, Vol. 9, No. 1, 1957, pp. 51-70.

Not abstracted.

510. Ziemba, S.,
DRY FRICTION VIBRATION DAMPING, Archiwum
Mechaniki Stosowanej, Vol. 9, No. 3, 1957, pp. 275-291.

Article discusses free vibration of damped systems having one degree of freedom. Dry friction and internal friction forces are taken into account.

511. Ziemba, S.,
THE INFLUENCE OF VISCOSITY DAMPING ON THE FORM OF THE TRAJECTORIES OF FREE VIBRATION, Archiwum
Mechaniki Stosowanej, Vol. 9, No. 4, 1957, pp. 487-504.

Not abstracted.

512. Ziemba, S.,
FREE VIBRATION WITH DAMPING OF MARKED NON-LINEAR CHARACTER, Archiwum
Mechaniki Stosowanej, Vol. 9, 1957, pp. 525-548.

Not abstracted.

513. Akashi, T. ,
DECREMENT OF THE ULTRASONIC PULSE INTENSITY
IN CONCRETE, Semento Gijutsu Nenpo, Vol. 12, 1958,
pp. 329-334.

The ultrasonic wave velocity in concrete is affected not only by the strength but also by the mixing proportions, moisture content, and other factors. Experimental formulas for calculating the compressive strength of wet and dry concretes by measuring the ultrasonic wave velocity and decrement constant are shown.

514. Akashi, T. and Yamaji, F. ,
DETERMINATION OF THE SETTING OF CONCRETE BY
THE ULTRASONIC METHOD, Semento Gijutsu Nenpo, Vol.
12, 1958, pp. 323-329.

The setting of concrete within 12 hours after molding was studied by measuring the ultrasonic wave velocity and amplitude with an oscillator of 20 kilocycles made with Batitanate, and by measuring the compressive strength.

515. Ashmarin, G. M. ,
THE INTERNAL FRICTION OF IRON-VANADIUM ALLOYS,
Proizvodstvo i Obrabotka Stali i Splavov, Moskov. Inst.
Stali im. I. V. Stalina, Sbornik, Vol. 38, 1958, pp. 461-475.

The effect of vanadium in the range of 1 to 25 percent by atomic weight on the temperature characteristic of internal friction of iron was investigated. The internal friction was determined in as-annealed and quenched conditions by a torsion pendulum. For the alloys annealed at 900° followed by cooling in a furnace, the internal friction in the range of 20° to 400° was characterized by a horizontal line parallel to the temperature axis. Above that temperature, the internal friction sharply increased. With increase in vanadium contents the high-temperature part of the curves was displaced toward the higher temperature. For an annealed alloy containing 12 percent V-a peak in the internal friction curve occurred in the range of 600°. A similar peak, but appearing at room temperature, was revealed for the alloys containing 1 and 2 percent vanadium and quenched from above 1300°.

516. Astrom, H. U.,
ANELASTICITY OF NITROGEN IN ALPHA-IRON, Arkiv för Fysik, Vol. 14, 1958, pp. 383-386.

New measurements were conducted to determine the elastic aftereffect versus time on a sample containing 0.095 percent by weight nitrogen at -12° , -24° , and -29° . The results indicated that the elastic aftereffect was time-dependent. Evidence of precipitation of solute nitrogen over long periods was noted. A good correlation of results with earlier work was obtained for nitrogen concentration less than 0.05 percent by weight. For higher concentration of nitrogen, the values were somewhat higher because of precipitation of solute nitrogen. From the data, the energy of dissociation was determined to be 2100 calories per mole. Other work supports the assumption that there is an interaction between adjacent nitrogen atoms.

517. Atomic Energy Commission,
CREEP AND ANELASTIC STUDIES ON ALUMINA by R. Chang, 1958, Report No. NAA-SR-2770, 24 pp.

Single crystals and polycrystals of Al_2O_3 containing various amounts of Cr_2O_3 and La_2O_3 in solid solution were studied with respect to steady-state creep and variation of internal friction and dynamic elastic contents with temperature. Addition of Cr_2O_3 or La_2O_3 lowers considerably the activation energy for grain-boundary relaxation, decreasing the grain-boundary viscosity at a given temperature.

518. Atomic Energy Commission,
APPARATUS FOR MEASUREMENT OF THE INTERNAL FRICTION OF METALS AT KILOCYCLE FREQUENCIES by E. W. Dickson and H. Strauch, October 1958, Report No. NP-12682.

An apparatus was constructed to measure the internal friction of metal specimens, in this case beryllium, at frequencies of ~ 30 kc/sec. It also allows a predetermination of the resonance frequency and hence Young's modulus for the specimen.

519. Atomic Energy Commission,
DAMPING IN METALS by R. Fichter, 1958, Report No.
IG-Inf. Ser. 14.

A report based on previously published articles is presented in which damping is treated as an aid in research on metallic structures. The causes of damping are described, and results of measurements in structural research are set forth. Nondestructive testing of materials with the aid of damping measurements is briefly reviewed.

520. Avraamov, Y. S., Belyakov, L. N., and Livshits, B. G.,
INTERNAL-FRICTION PEAKS IN NICKEL-CHROMIUM-
BASE SOLID SOLUTIONS, Akademii Nauk, SSSR, Fizika
Metallov i Metallovedenie, Vol. 6, No. 1, 1958, pp. 116-
121 (In Russian) (Physics of Metals and Metallography, Vol.
6, No. 1, 1958, pp. 104-108, English Translation).

The variation of internal friction with temperature was used to investigate the processes of the anomalous aging in Nichrome and Nimonic alloys. The peak in the latter alloy is associated with the presence of titanium atoms in solid solution. This technique can serve as a method of analyzing transformations in substitutional solid solutions even at low solute concentrations.

521. Avraamov, Y. S., Livshits, B. G., and Osvenskii, V. B.,
CHANGE OF STRUCTURE TRANSFORMATIONS IN
PERMALLOY, ALLOYED WITH MOLYBDENUM, Akademii
Nauk, Izvestiya, Seriya Fizicheskaya, Vol. 22, 1958, pp.
1263-1268.

The electric resistivity, the hardness, and the temperature dependence of internal friction and of saturation magnetization were measured on four alloys containing nickel 74.5 to 6.0, iron 18.8 to 24.15, molybdenum 0 to 5.15 and carbon 0.0093 percent. The temperature dependence of internal friction was measured with a vacuum relaxation apparatus. Introduction of molybdenum increases internal friction and produces two peaks, one around 85°, the other around 170°. These peaks disappear after tempering for 12 hours at 400°.

522. Baccaredda, M., Butta, E., and Caputo, R.,
DYNAMIC MECHANICAL PROPERTIES OF CERTAIN
PLASTICIZED HIGH POLYMERS, Chimie et Industrie,
Vol. 40, 1958, pp. 356-361 (Sixteenth International Congress
on Pure and Applied Chemistry, Paris, 25-26 July 1957).

Sound velocity (V) and damping factor (d. i.) are measured in plasticized samples of polyvinyl chloride and polystyrene at temperatures from -70° to 120°C and at frequencies from 1 to 10 kc/sec. All the observed effects increase with increased plasticizer content and, at equal weight contents of the latter with increased molecular length.

523. Barducci, I.,
ANELASTIC BEHAVIOR OF SOLIDS AT HIGH TEMPER-
ATURES, Ricerca Scientifica, Vol. 28, No. 2, February
1958, pp. 313-322 (In Italian).

A brief review of the chief characteristics of the behavior and the theoretical interpretations advanced by Bordone and Nuovo and by Mason is followed by a discussion of the experimental results on the binary alloys tin-lead, bismuth-antimony and Wood's metal, which contribute to the determination of the dependence of the logarithmic decrement upon the frequency of oscillation and the temperature (T). It is confirmed that the decrement is proportional to exponent $(-1/T)$ in accordance with both theories, but neither theory offers a satisfactory relation for the dependence on frequency.

524. Barkhatov, A. N. and Shmelev, I. I.,
THE ATTENUATION OF A SOUND BEAM ON TRAVERSING
A LAYER HAVING VELOCITY DISCONTINUITY,
Akusticheski Zhurnal, Vol. 4, No. 2, 1958, pp. 125-127.

The results of some experimental measurements are given, together with an evaluation of them in terms of geometrical theory.

525. Barnes, R. S. and Hancock, N. H.,
THE EFFECTS OF NEUTRON IRRADIATION UPON THE
INTERNAL FRICTION OF COPPER SINGLE CRYSTALS AT
LIQUID NITROGEN TEMPERATURES, Philosophical
Magazine, Vol. 3, Series 8, May 1958, pp. 527-530.

The internal friction of copper single crystals remains unaffected by a short neutron bombardment at -195° C if no warming is allowed before measurement. Successive pulse anneals produce no marked change until 23° C is reached, when the internal friction is greatly reduced.

526. Barnes, R. S., Hancock, N. H., and Silk, E. C. H.,
THE INFLUENCE OF VACANCIES UPON THE INTERNAL
FRICTION OF POLYCRYSTALLINE COPPER, Philosophical
Magazine, Vol. 3, Series 8, May 1958, pp. 519-526.

Neutron irradiation, gamma irradiation, and quenching change the internal friction of pure polycrystalline rods of copper. Only if the rods are initially given an anneal near the melting point for many hours do these three treatments give consistent and similar results, and then the logarithmic decrement is reduced. It is concluded from the results that it is the vacancies introduced by each of the three treatments which pin the dislocation lines by diffusion to them, and that unless the purity of the copper is high their effect can be obscured.

527. Bass, R.,
THEORY OF THE MECHANICAL RELAXATION OF ICE,
Zeitschrift für Physik, Vol. 153, 1958, pp. 16-37.

Based on a statistical structure, the mechanical relaxation phenomena of ice are calculated in terms of the electrostatic interaction of adjacent hydrogen bonds. The results explain the dependence of the damping maxima on temperature and crystallographic orientation and lead to an estimate for the dipole moment of the hydrogen bond of $\leq 0.35 \times 10^{-18}$ electrostatic units.

528. Bass, R.,
A THEORETICAL ANALYSIS OF THE MECHANICAL
RELAXATION OF SINGLE-CRYSTALLINE ICE,
Proceedings of the Royal Society, Vol. 247, Series A,
21 October 1958, pp. 462-464.

Two relaxation mechanisms are considered: 1) disturbance of equilibrium between a large number of possible hydrogen arrangements by mechanical deformation of the lattice and 2) redistribution of lattice defects, such as doubly occupied and vacant bonds between neighbouring oxygen atoms. Calculations show that mechanism 1) is consistent with experimental results, where as mechanism 2) is not.

529. Benbow, J. J. and Wood, D. J. C.,
CORRELATION OF INTERNAL FRICTION AND CHEMICAL
STRUCTURE IN ORGANIC GLASSES, Faraday Society,
Transactions, Vol. 54, 1958, pp. 1581-1587.

The internal friction was calculated from measurements of the phase angle between the stress and strain at frequencies above 1 cps and of the logarithmic decrement at frequencies above 1 cps at 16° to 26°. At the lower frequencies, the glasses differed by the extent to which the dependence of the internal friction on frequency conforms to the theoretical predictions for a Maxwell body. The frequency range over which this conformity was observed could be linked qualitatively with the effective size of the glass molecules, the existence of intermolecular association being considered.

530. Bishop, R. E. D. and Johnson, D. C.,
ON DAMPED FREE VIBRATION WITH PARTICULAR
REFERENCE TO SYSTEMS HAVING NEARLY-EQUAL
NATURAL FREQUENCIES, Aeronautical Quarterly, Vol. 9,
Part 1, 1958, pp. 71-96.

This paper investigates the free vibration of linear systems which are subject to damping. Using an analytical method, the approximate theory for small damping is derived, showing the nature of the entrainment of the principal modes; the results are found to confirm those of Southwell (who uses a physical argument) and are

illustrated by an example. The approximate theory is shown to need modification when there are two nearly-equal natural frequencies, and the appropriate corrections are found.

531. Bömmel, H. E. and Mason, W. P. ,
ULTRASONIC ATTENUATION IN SUPERCONDUCTOR,
Bell Laboratories Record, Vol. 36, No. 7, 1958,
pp. 253-256.

Experimental results are reported for lead and tin. The effects of the superconducting transition and a superimposed magnetic field on the attenuation are discussed.

532. Boulanger, C. ,
PROCESS OF RELAXATION AT ELEVATED TEMPERA -
TURES, Revue de Métallurgie, Vol. 55, 1958,
pp. 889-898.

The internal friction and elastic modulus for various metals and alloys was studied with the aid of a "hysteresis meter" at different temperatures. The results obtained on ferrosilicon containing 3.24 percent silicon, Armco iron, iron, molybdenum, steel containing 0.7 percent carbon, and iron-nickel-chromium are shown.

533. Bradfield, G. and Levi, F. A. ,
MEASUREMENTS OF ELASTICITY AND ANELASTICITY
OF SMALL DISKS BY AN INDUCTOR METHOD, British
Journal of Applied Physics, Vol. 9, 1958, pp. 13-16.

An instrument is described on the inductor principle to set a small disk into radial vibration so that one of its elastic constants can be determined from its frequencies of resonance. The method of testing also permits the internal friction to be measured as the ratio (Q_m) of the real to the imaginary component of the elastic compliance. The accuracy of determination of the resonance frequency is to better than 1 part in 50 in a typical case, when, for example, the Q_m is about 3000.

534. Brown University, Division of Engineering Technology,
Providence, Rhode Island,
AN EXPERIMENTAL INVESTIGATION OF THE INTERNAL
FRICTION OF THIN PLATINUM ALLOY WIRES AT LOW
FREQUENCIES by J. Kestin and J. M. Moszynski, July
1958, Report No. 11, AFOSR TN 58-752, ASTIA AD-201 516.

This report describes the design of a special high-vacuum calibration unit for suspension wires used in viscometry. Results concerning the internal damping of platinum-tungsten wires and the temperature effect on their elastic properties are given.

535. Brown University, Providence, Rhode Island,
THE VALIDITY OF MODEL REPRESENTATION FOR
LINEAR VISCOELASTIC BEHAVIOR by H. Kolsky and Y. Y.
Shi, January 1958, Technical Report No. 5, Contract NONR
562(14) NR-064-421.

Not abstracted.

536. Brown University, Providence, Rhode Island,
ULTRASONIC ATTENUATION BY ELECTRONS IN METALS
AT LOW TEMPERATURES by H. V. Bohm, 1958, Ph.D.
Thesis.

In pure tin and indium samples, where the mean free path of an electron can be made longer than the wavelength of sound, the compressional wave attenuation data lend experimental support to a recent theory of superconductivity by Bardeen, Cooper, and Schrieffer (BCS theory). In particular, satisfactory agreement is found with the theoretically predicted energy gap in the electron energy distribution of a metal in the superconducting state. Results of experiments on the magnetic field dependence of the attenuation in normal metals indicate that this technique is a potentially powerful tool in studying Fermi energy surfaces in metals.

537. Bungardt, K., Bauser, M., and Sychrovsky, H.,
DAMPING INVESTIGATIONS OF A STEEL WITH 12% Cr
AND 1% Mo, Archiv für das Eisenhüttenwesen, Vol. 29,
No. 7, 1958, pp. 415-422.

Not abstracted.

538. Bungardt, K. and Preisendanz, H. ,
INFLUENCE OF COLD DEFORMATION ON THE DAMPING
OF IRON-CHROMIUM ALLOYS, Archiv für das
Eisenhüttenwesen, Vol. 29, 1958, pp. 241-247.

The previously discovered maximum of the damping value at 220° was more closely investigated with respect to its dependence on quenching and cold-deformation conditions in iron-chromium alloys at 6 to 45 percent chromium. The damping maximum at 220° is explained to be due to a solution of the nitrogen in the iron-chromium solid solution crystal in the interlattice places.

539. Burton, R. ,
VIBRATION AND IMPACT, Addison-Wesley Publishing
Company, Incorporated, Reading, Massachusetts, 1958,
310 pp.

The objectives of the book are to develop methods for finding the natural frequencies of a vibrating system, to study forced vibrations and damping, and to study self-excited vibration. A portion of the book is devoted to extending the concepts of mechanical vibration to systems other than those made up of springs and masses. Book is illustrated.

540. Caswell, H. L. ,
INVESTIGATION OF LOW-TEMPERATURE INTERNAL
FRICTION, Journal of Applied Physics, Vol. 29, No. 8,
August 1958, pp. 1210-1214.

The internal friction in pure copper, in copper doped with nickel and gold, and in magnesium subjected to various amounts of cold work was measured at 40 kc/sec from 4° K to 300° K. Cold work produces a Bordoni relaxation peak in copper at approximately 80° K. The peak position is independent of the amplitude of vibration for strain amplitudes less than 3×10^{-5} . Suitable annealing reduces and eliminates the peak, as does the presence of relatively large quantities of impurities. Increased cold work and impurity additions also systematically reduce the strain amplitude of the internal friction. A peak was found in cold-worked magnesium at 20° K, and a small peak in crystalline quartz at 39° K. A comparison of present theories with these results is given.

541. Chaevskii, M. I.,
INFLUENCE EXERCISED BY THE FORCES OF INTERNAL
FRICTION ON THE STABILITY OF THE MOTION OF
RAPIDLY ROTATING SHAFTS, Trudi Nauchno-Tekh.
Soveschaniya po Izuch. Rasseyaniya Energii pri Kilebaniyakh
Uprugikh Tel, Kiev, Akad. Nauk USSR, 1958, pp. 90-103.

The problem is investigated regarding the stability of motion of a vertical ideally balanced two-span and cantilever shaft with a disc midway in the span when under the action of internal and external friction. The mechanism gives rise to forces of internal friction. These forces are determined by means of the hypothesis of linear and nonlinear elastic hysteresis; the forces of external friction are determined by the hypothesis of the proportionality of the velocity of change of curvature of the shaft below the disc.

542. Ch'eng, K. and Chang, H. K.,
THEORY OF INTERNAL FRICTION IN A FACE-CENTERED
CUBIC LATTICE, Wu Li Hsueh Pao, Vol. 14, 1958, pp. 71-81.

The possible types of mechanisms are given that would give rise to internal friction in a face-centered cubic crystal. The asymmetry is due to the presence of the Schottky defects, in which a pair of carbon atoms orient themselves in accordance with the direction of external strain; the possible location of the pair may be such that one carbon atom is located in the center of the hole and the other is in an interstitial point adjacent to the hole. The calculated and the experimental curves for the internal friction strength are compared and found to agree remarkably. Furthermore, the free energy evolved in trapping a carbon atom in a Schottky hole can be estimated to about the order of 0.14 electron volts.

543. Chernikova, I. N. and Finkelshtein, B. N.,
THE EFFECT OF TEMPERING ON THE SHEAR MODULUS
AND INTERNAL FRICTION OF QUENCHED CARBON STEEL,
Proizvodstvo i Obrabotka Stali i Splavov, Moskov. Inst.
Stali im. I. V. Stalina, Sbornik 38, 1958, pp. 476-482.

The shear modulus and internal friction in the range of 20° to 650° for carbon steels containing from 0.010 to 0.58 percent carbon were determined. In the temperature characteristics of internal friction, a peak was revealed in the range of 200°. The height of the peak in that temperature

range regularly increased with the increase in carbon content and decreased with the increase in tempering temperature.

544. Chopra, K. L. and Hutchison, T. S.,
ULTRASONIC ATTENUATION IN SUPERCONDUCTING
ALUMINUM, Canadian Journal of Physics, Vol. 36, No. 6,
June 1958, pp. 805-806.

The attenuation of 20 mc/sec longitudinal ultrasonic waves in normal and superconducting polycrystalline aluminum (purity > 99.99 percent) was studied between 0.84° and 1.6° K. Comparison with theory was restricted by inability to achieve a low enough temperature. Absorption hysteresis was also noted on the destruction and restoration of superconductivity with a magnetic field.

545. Cisman, A., Rothenstein, B., and Hrinca, J.,
ON THE NATURE OF THE MAGNETOMECHANICAL EFFECT
IN ALTERNATING MAGNETIC FIELDS, Czechoslovak
Journal of Physics, Vol. 8, 1958, pp. 374-375.

Not abstracted.

546. Collette, G.,
APPARATUS TO MEASURE THE INTERNAL FRICTION OF
TEST BARS, Comptes Rendus, Vol. 246, 1958, pp. 2756-
2758.

An apparatus is described which measures at ambient temperature the coefficient of internal friction in test bars subjected to alternate stresses of low frequency. A linear relation exists between dissolved nitrogen in iron and the coefficient of friction of samples under the experimental conditions described, up to 140 parts per million nitrogen.

547. Crandall, S., Editor,
STRUCTURAL DAMPING, Random Vibration, Cambridge,
Massachusetts and New York, New York, jointly Technology
Press of Massachusetts Institute of Technology and John
Wiley and Sons, Incorporated, 1958 (Chapter 5 by T.H.H.
Pian).

In the past, all the investigations on structural damping problems have been associated with vibrations under repeating cycles. One of the most common methods to define the

magnitude of structural damping, for example, is in terms of energy loss per cycle of vibration. Up to the present time no published work can be found on the discussion of structural damping in conjunction with random vibrations. The present discussion is thus confined essentially to the conventional investigations of structural damping.

548. Dannhauser, W., Child, W. C., Jr., and Ferry, J. D., DYNAMIC MECHANICAL PROPERTIES OF POLYOCTYL METHACRYLATE, Journal of Colloid Science, Vol. 13, 1958, pp. 103-113.

Polyoctyl methacrylate of wt. -av. mol. wt. 3,620,000 was compared with methacrylate polymers previously studied by using the same transducer method to measure the complex shear compliance over the range 15-3600/sec and from -14° to 130°.

549. Darling, A. S., KINETICS OF RECOVERY OF COLD-WORKED (CADMIUM) FROM INTERNAL FRICTION AND ELASTICITY MEASUREMENTS, Institute of Metals, Bulletin, Vol. 4, No. 13, 1958, pp. 91-92.

Kamel and Attia in a study of the kinetics of recovery during annealing, followed by internal friction and elasticity measurements, concluded that the two processes were uniquely related. In this article, the data are replotted for different degrees of recovery, and the Kamel and Attia theory is questioned. The difference may be due to the internal friction measurements being influenced by impurities for small increments of strain, whereas the recovery of the elastic modulus is not.

550. Datsko, O. I. and Pavlov, V. A., INTERNAL FRICTION OF PURE NICKEL IN RELATION TO TEMPERATURE, Akademii Nauk, SSSR, Fizika Metallov i Metallovedenie, Vol. 6, No. 5, 1958, pp. 900-904.

Maximum internal friction of pure recrystallized nickel in the 440° to 460° C range depends upon stress relaxation along grain boundary. With increase of annealing temperature, the maximum friction is reduced and is not displaced noticeably from the high-temperature region.

551. Deeley, C. W., Sauer, J. A., and Woodward, A. E.,
DYNAMIC MECHANICAL BEHAVIOR OF IRRADIATED
POLYETHYLENE, *Journal of Applied Physics*, Vol. 29,
No. 10, October 1958, pp. 1415-1421.

Samples of a high density polyethylene irradiated in a nuclear reactor to thermal neutron doses as high as 2.9×10^{18} nvt bombardment from a Co^{60} source up to a dosage of 1×10^9 rep have been investigated by dynamic mechanical methods from 80° to 450° K at audio frequencies.

552. Deeley, C. W., Kline, D. E., Sauer, J. A., and Woodward, A. E.,
EFFECT OF PILE IRRADIATION ON THE DYNAMIC
MECHANICAL PROPERTIES OF POLYETHYLENE, *Journal of Polymer Science*, Vol. 28, 1958, pp. 109-120.

The effects of pile irradiation on the damping and resonant frequency of a high-pressure polyethylene has been investigated over a temperature range from 80° to 550° K. By using irradiation dosages which result in approximately four percent cross-linking or greater, the mechanical loss peaks found at about 165° , 265° , and 355° K in polyethylene are altered. The 355° K peak, attributed to the melting of the crystalline portions of the sample, decreases in height and shifts to lower temperatures with increasing irradiation dose. The damping behavior in the 165° and 265° K regions is discussed in terms of a diffusional motion of chain segments in the amorphous polymer portions.

553. Dekartova, N. V., Rozhanskii, V. N., and Shchukin, E. D.,
RECORDING OF THE DAMPING OF THE OSCILLATIONS
OF A TORSIONAL PENDULUM ON A LOOP OSCILLOGRAPH
DURING THE MEASUREMENT OF INTERNAL FRICTION,
Instruments and Experimental Techniques, No. 6, 1958,
pp. 821-823.

Not abstracted.

554. Dickenscheid, W. and Seeman, H. J.,
DAMPING AND AGING OF ALLOYS IN THE IRON-CARBON-
PHOSPHORUS SYSTEM, *Revue de Metallurgie*, Vol. 55,
September 1958, pp. 872-875.

Damping measurements made by torsional pendulum on artificially aged alloys revealed diminution of maximum

value of SNOEK-damping with increasing phosphorus content, unchanged temperature of maximum damping, assymetric damping-temperature curves for higher phosphorus contents, influence of phosphorus and carbon on residual damping.

555. Doremus, R. H. ,
THE ROLE OF DISLOCATIONS IN CARBIDE PRECIPITA-
TION IN ALPHA-IRON, Acta Metallurgica, Vol. 6, 1958,
pp. 674-679.

Ferrovac E vacuum-melted iron was tested. The experiments indicated that carbon atoms segregate to dislocations. These segregated atoms form growth nuclei on the dislocation lines. The nuclei grow in certain preferred planes to form thin disks. The platelike particles grow by diffusion of carbon through the matrix.

556. Einspruch, N. G. and Truell, R. ,
MEGACYCLE ATTENUATION AND BORDONI PEAKS,
Physical Review, Vol. 109, No. 3, 1 February 1958, pp.
652-653.

Results of Bordoni-peak measurements made at 10, 30, and 60 mc/sec in relatively impure deformed polycrystalline aluminum are compared with previous measurements at 5 mc/sec and 40 kc/sec. The observed difference between the results of these measurements and those of previous measurements appears to depend on the purity of the material.

557. Endo, K. , Yoshikawa, S. , and Yamada, A. ,
EXPERIMENTAL STUDIES ON TEMPERATURE INCREASE
IN SPECIMENS DURING FATIGUE TEST, Japan Society of
Mechanical Engineers, Transactions, Vol. 24, November
1958, pp. 767-771.

Temperature increase is a function of the magnitude of cyclic stresses, and a relationship is found between the increase and the life of the specimen. Damping constant is influenced by the temperature of the specimen and has no relation to the magnitude or the cyclic number of stresses.

558. Evans, L. M. ,
CONTROL OF VIBRATION AND NOISE FROM CENTRI-
FUGAL PUMPS, Noise Control, Vol. 4, 1958, pp. 28-31.

Quiet operation of centrifugal pumps is an important consideration not only in air conditioning, but also for industrial applications. To insure a quiet-operating pump, the most important step is to select the pump to operate at its best efficiency point. The next step is to isolate the unit from the system by using isolation mounting to prevent transmission of any remaining noise or vibration down through the foundation to the building structure.

559. Fichter, R. ,
DAMPING VIBRATIONS IN METALS, Schweizer Archiv für
Angewandte, Wissenschaft und Technik, Vol. 24, 1958,
pp. 65-78.

A review of vibrational damping as it can be applied to the determination of structure and to an understanding of corrosion.

560. Filekin, V. P. ,
THE FREE, NONLINEAR OSCILLATIONS OF A BEAM WITH
EXTERNAL RESISTING MOMENTS, Trudi Kuibyshevsk.
Aviats. In-ta. , Vol. 6, 1958, pp. 87-89.

A solution is given for the nonlinear differential equation of the free oscillations of a beam with internal and external resisting moments. The resisting forces are assumed to be applied in the form of a distributed load to the beam; the load expressed by a small parameter and a particular function of the rate of oscillation of a selected point of the beam.

561. Filmer, A. J. , Hutton, G. J. , and Hutchison, T. S. ,
INTERNAL FRICTION IN ALUMINUM AT LOW
TEMPERATURES, Journal of Applied Physics, Vol. 29, No.
2, February 1958, pp. 146-148.

Preliminary measurements at 40 kc/sec of the internal friction of 99.992 percent aluminum as a function of temperature yield a number of attenuation maxima at temperatures between 90° and 300°K. They appear to be of two types: a broad maximum at about 225°K and a series of

very sharp peaks at lower temperatures. The latter are tentatively associated with the breakaway of dislocations from minor pinning points.

562. Fine, M. E. and Greener, E. H.,
INTERNAL FRICTION AND YOUNG'S MODULUS OF
HEXAGONAL AND CUBIC COBALT, Metallurgical Society
of American Institute of Mining, Metallurgical, and
Petroleum Engineers (AIME), Transactions, Vol. 212,
August 1958, pp. 476-478.

Internal friction rises rapidly above 200°C, but shows no hysteresis or cooling. There is no large change in either modulus or internal friction during the transformation.

563. Garber, R. I. and Mogilnikova, T. T.,
INTERNAL FRICTION AND PLASTIC DEFORMATION OF
OVERSTRESSED MICROREGIONS OF A SOLID, Doklady
Akademii Nauk, SSSR, Vol. 118, No. 3, 21 January 1958,
pp. 479-482.

In torsional oscillations of a tube of lead the logarithmic decrement is independent of amplitude and of constant additional stresses imposed by applying pressure inside the tube. But the internal friction is increased by an amount depending on the applied pressure and on the rate of increase of applied pressure at rates exceeding about 0.04 atmospheres per second. The results are explained in terms of the creation during elastic deformation of nonhomogeneous microregions where plastic deformation occurs.

564. Garber, R. I. and Kovalev, A. I.,
TEMPERATURE DEPENDENCE OF THE MODULUS OF
ELASTICITY OF IRON, Zavodskaya Laboratoriya, Vol. 24,
1958, pp. 477-479.

A high-vacuum apparatus is described for the study of the temperature dependence of the modulus of elasticity (E) and of shear (G), and for the study of the decrease of damping of iron in the temperature interval from room temperature to 1000°. The necessary measurements on one sample can be carried out at frequencies from 1 to 12 cycles.

565. Gebhardt, E., Seghezzi, H. D., and Dürrschnabel, W.,
STUDIES ON THE TANTALUM-NITROGEN SYSTEM,
Zeitschrift für Metallkunde, Vol. 49, No. 11, 1958, pp. 577-
583.

The internal friction increases with increasing nitrogen content up to 1.7 percent and is greater for coarse-grained than for fine-grained material, indicating that nitrogen enrichment occurs preferentially at grain boundaries. The activation energy for diffusion of nitrogen atoms in the tantalum is 36.4 kilocalories per mole.

566. Gershuni, G. Z. and Zhukhovitskiy, Y. M.,
FORCED VIBRATIONS IN AN ELASTO-PLASTIC SYSTEM,
Akademii Nauk, SSSR, Fizika Metallov i Metallovedenic,
Vol. 6, No. 2, 1958, pp. 339-346.

Forced vibrations in an elasto-plastic system beyond the elastic limit are considered. Friction and hysteresis are taken into account. The resonance properties of such a system are discussed and compared with the experimental data.

567. Gibbons, D. F. and Chirba, V. G.,
ACOUSTICAL LOSS AND YOUNG'S MODULUS OF
YTTRIUM IRON GARNET, Physical Review, Vol. 110,
1958, pp. 770-771.

Young's modulus and acoustical attenuation at 84.8 and 249.2 kc/sec in polycrystalline $Y_3Fe_2(FeO_4)_3$ were measured at zero to 320° K, and the results are discussed.

568. Giles, C. G. and Sabey, B. E.,
RUBBER HYSTERESIS AND SKIDDING RESISTANCE,
Engineering, Vol. 186, No. 4842, 1958, pp. 840-842.

Braking damage to tires, which is found to be most severe just below the contact point, is also explained by consideration of hysteresis effects.

569. Goering, W. A. and Nowick, A. S.,
ANELASTIC MEASUREMENTS ON THE ALLOY Cu_3Au ,
American Institute of Mining, Metallurgical, and Petroleum
Engineers (AIME), Transactions, Vol. 212, February 1958,
pp. 105-106.

Measurements of the internal friction as a function of temperature were made in a torsion pendulum.

570. Granato, A., Hikata, A., and Lücke, K.,
RECOVERY OF DAMPING AND MODULUS CHANGES
FOLLOWING PLASTIC DEFORMATION, Acta Metallurgica,
Vol. 6, 1958, pp. 470-480.

A theory is developed which assumes that changes with time in the decrement and modulus of a crystalline material following plastic deformation are a result of dislocation pinning by deformation-induced point defects.

571. Greenwood, J. A. and Tabor, D.,
THE FRICTION OF HARD SLIDERS ON LUBRICATED
RUBBER: THE IMPORTANCE OF DEFORMATION LOSSES,
Physical Society, Proceedings, Vol. 71, June 1958, pp. 989
1001.

A study was made of the friction of hard spheres and cones on a well-lubricated rubber surface under conditions where relatively large deformations are produced. It was found that with spheres the sliding friction is almost the same as the rolling friction. Earlier work showed that in the latter case the friction arises primarily from hysteresis losses in the rubber, and it is concluded that, under the experimental conditions described, the main source of friction in lubricated sliding arises from the same cause. With conical sliders, it is not possible to make a direct comparison with rolling experiments, but a simple calculation suggests that here again the friction is largely due to deformation losses in the rubber.

572. Hashiguchi, R. and Kiyoura, R. ,
FUNDAMENTAL RESEARCHES ON THE PHYSICAL
METALLURGY OF NUCLEAR FUELS IN JAPAN, Second
United Nations International Conference on Peaceful Uses
of Atomic Energy, Proceedings, Vol. 6, 1958, pp. 34-41.

The growth of uranium as the result of thermal cycling was examined by means of internal friction measurements at low temperature (from room temperature down to that of liquid air). The activation energy for this on the slip-and-twin theory of growth, a new mechanism is proposed which assures the unidirectional growth by virtue of its irreversibility.

573. Hellwege, K. H., Kaiser, R., and Kuphal, K. ,
TORSIONAL OSCILLATIONS IN STRETCHED HIGH
POLYMERS, Kolloid-Zeitschrift, Vol. 157, 1958, pp. 27-37.

Using free torsional oscillation on stretched and unstretched test pieces of polyethylene, Teflon, polyamide and polyurethane, the influence of elongation on these partially crystalline polymers was investigated. In a separate section, equations between elastic values and loss values are derived to describe the behavior of an anisotropic strip with a preferred direction during torsion.

574. Hiki, Y. ,
INTERNAL FRICTION OF LEAD, Physical Society of Japan,
Journal, Vol. 13, pp. 1138-1144.

A composite quartz oscillator was used to measure the logarithmic decrement of lead single crystals (99.99 percent pure). The dependence of the decrement on the strain amplitude (0.5 to 12×10^{-6}), frequency (64 and 192 kc/sec), and temperature (140° to 340° K) was studied.

575. Hirone, T. and Kamigaki, K. ,
ATTENUATION OF THE ULTRASONIC WAVES IN METALS.
PART 2. STAINLESS STEEL, Tohoku University, Science
Reports of the Research Institutes, Vol. 10, August 1958,
pp. 276-282.

Pulse ultrasonic waves at frequencies ranging from 0.5 to 6 mc/sec were used to measure attenuation of austenitic 19 to 10 chromium-nickel stainless steels with various grain

sizes. Attenuation coefficient increased with frequency and grain size. Attenuation behavior is explained by assuming that the traveling ultrasonic waves were scattered by austenite grains in accordance with Rayleigh's law.

576. Hutchison, T. S. and Hutton, G. J.,
THE EFFECT OF HEAT-TREATMENT ON LOW-
TEMPERATURE INTERNAL-FRICTION MAXIMUMS,
Canadian Journal of Physics, Vol. 36, 1958, pp. 82-87.

The attenuation of sound at a frequency of five megacycles was measured over the temperature range 100° to 200° K on polycrystalline high-purity aluminum subjected to various thermal and mechanical treatments.

577. Ibragimova, D. M. and Moiseev, A. I.,
INTERNAL FRICTION PEAK OBSERVED IN TESTING
DEFORMED ALUMINUM, Akademii Nauk, SSSR, Fizika
Metallov i Metallovedenie, Vol. 6, 1958, pp. 952-953.

Cold-worked pure aluminum showed two internal friction peaks on the friction-temperature curves; the same material annealed after cold-working showed only one peak. The first peak at about 350° is due to stress relaxation at grain boundaries as shown by Kê; the second peak to relaxation at local plastic deformations within the cold-worked crystal.

578. Ikeda, T.,
INTERNAL FRICTION OF BARIUM TITANATE CERAMICS,
Physical Society of Japan, Journal, Vol. 13, 1958, pp. 809-818.

It was found that the internal friction of BaTiO₃ ceramics depended on temperature, biasing field, and vibration amplitude, but was nearly independent of frequency and porosity. From this, it was concluded that the internal friction was due primarily to the single domain crystal, which is intrinsically dielectric and acts through piezoelectric coupling.

579. Imoto, S. and Mima, G.,
INTERNAL FRICTION OF OXYGEN BEARING COPPER III,
Japanese Institute of Metals, Journal, Vol. 22, No. 11,
1958, pp. 584-587.

The internal friction of copper specimens containing various amounts of oxygen and zinc or nickel was measured.

When the oxygen content sufficed to oxidize all the zinc, the internal friction was high and showed a maximum with increasing strain amplitude; with lower oxygen content, it was low and increased monotonically with amplitude. In nickel-containing specimens, the internal friction was low and showed no maximum even when sufficient oxygen was present to oxidize all of the nickel.

580. Imoto, S. and Mima, G.,
INTERNAL FRICTION OF SULPHUR-(SELERIUM,
TELLURIUM)-BEARING COPPER, Japanese Institute of
Metals, Journal, Vol. 22, No. 11, 1958, pp. 588-592.

Internal friction was measured in sulphur-containing copper specimens. In the as-cast state, it increased monotonically with strain amplitude. Annealing at 600° C reduced the internal friction, which showed a faint maximum with increasing amplitude. With higher annealing temperature, the internal friction increased and the maximum was more prominent. Selerium- and tellurium-bearing copper specimens fully-annealed behaved similarly to sulphur- and oxygen-bearing copper.

581. Ip, C. U. and Morse, I. E.,
VARIABLE-SPEED TORSIONAL-VIBRATION ABSORBER
(ACCOMMODATES CHANGES IN THE FREQUENCY OF
IMPRESSED VIBRATIONS), Machine Design, Vol. 30, No.
16, 7 August 1958, pp. 93-95.

A variable-speed absorber with a spring whose stiffness varies with the square of the impressed frequency can be achieved by using an electromagnetic "spring." This permits "tuning" the absorber across an entire range of impressed vibrations to permit absorption throughout the range. The stiffness of an electromagnetic spring varies with the square of the field current of the electromagnet. Therefore, adjustments in the field current are made proportional to variations in the impressed frequency.

582. Jacobsen, L. S. and Ayre, R. S.,
ENGINEERING VIBRATIONS, WITH APPLICATIONS TO
STRUCTURES AND MACHINERY, New York, New York,
McGraw-Hill Book Company, Incorporated, 1958, 564 pp.

Problems of transient response and of nonlinear vibration are given nearly equal consideration with problems of

harmonic vibration. This broad treatment is found to be feasible by employing a simple, but very general technique which at the same time provides an exceptionally clear physical insight into the problem of dynamic response, namely, the phase-plane method of graphical integration of differential equations. Phase-plane methods have long been employed in physics and mathematics as a valuable aid in the study of the behavior of certain solutions of differential equations, particularly in the neighborhood of singular points. It is this latter aspect which has proved so important in the development of nonlinear mechanics theory. However, more recently the phase-plane concept has been developed into a truly valuable tool for the integration of differential equations, the authors of the present volume having played a significant part in this development. Thus a more or less systemized technique for treating harmonic, nonharmonic, and transient vibrations forms the essential basis for the present book.

583. Kataev, G. I.,
APPARATUS FOR PRECISE DETERMINATION OF TEMPERATURE DEPENDENCE OF YOUNG'S MODULUS AND DAMPING DECAY, Zavodskaya Laboratoriya, Vol. 24, October 1958, pp. 1258-1261.

A block diagram of the device is given. It covers the temperature range of zero to 600° C and is fitted with a magnetic coil for the suppression of magnetoelastic effects.

584. Kemnitz, G.,
INVESTIGATIONS OF NOTCH FATIGUE AND DAMPING PHENOMENA IN TIRE CORD, Proceedings, Deutsche Kautschuk Ges., Cologne, 7-10 May 1958, p. 26.

Measurements were made of the preloading elongation, the specific damping or energy loss per cycle as well as the elastic and plastic behavior, from the behavior of the elastic and viscous modulus.

585. Khilchevskii, V. V.,
A PROCEDURE FOR THE EXPERIMENTAL INVESTIGATION OF THE DISSIPATION OF ENERGY IN MATERIAL, Trudi Nauchno-Tekh. Sovechaniya po Izuch., Rasseyaniya Energii pri Kolebaniyakh Uprugikh Tel, Kiev, Akad. Nauk SSSR, 1958, pp. 165-173.

The technical details of the experiment carried out on an apparatus of the G. S. Pisarenko system ("Problems in

Powder Metallurgy and Strength of Materials", Izd-vo Akad. Nauk SSSR, Kiev, No. 1, 1954, pp. 33-39) are described. The basis of the work is the means used for the determination of the dissipation of energy in the material by the free transverse vibrations of plane samples, which are in conditions of pure deflection. For recording, a simple optical device is used. The obtained decrements of vibrations are linked with the values of the maximum normal stress in the section of the sample.

586. King, J. C.,
ANELASTICITY OF SYNTHETIC CRYSTALLINE QUARTZ
AT LOW TEMPERATURES, Physical Review, Vol. 109, No.
5, 1958, pp. 1552-1553.

The stress-induced relaxation absorption occurring at 50° K for a frequency of 5 mc/sec in natural quartz is 10^3 larger in some samples of synthetic quartz. The absorption depends on the crystallographic orientation of the seed plate on which the quartz was grown.

587. Kisin, B. I.,
USE OF A COMPOSITE PIEZO RESONATOR FOR DETER-
MINING MODULUS OF ELASTICITY AND INTERNAL FRIC-
TION OF HARD BODIES, Zavodskaya Laboratoriya, Vol. 24,
No. 11, 1958, pp. 1400-1403.

The use of the piezoelectric resonator is discussed, along with the formula and methods necessary to measure dynamic modulus and damping.

588. Knopoff, L. and MacDonald, G. J. F.,
ATTENUATION OF SMALL AMPLITUDE STRESS WAVES
IN SOLIDS, Reviews of Modern Physics, Vol. 30, No. 4,
October 1958, pp. 1178-1192.

Earlier theoretical work and laboratory and seismic measurements of attenuation at small strains are reviewed. The specific dissipation function of both longitudinal and torsional vibrations of many solids are frequency independent over a wide range. As the usual linear attenuation theories do not give this frequency dependence, a nonlinear permanent deformation model is considered. The model is analyzed in detail for wave and pulse propagation.

589. Koster, W. and Lang, W.,
YOUNG'S MODULUS AND DAMPING OF CADMIUM-
MAGNESIUM ALLOYS, Z. Metallik, Vol. 49, 1958, pp. 419-
423.

The formation of the phases Cd_3Mg , $CdMg$, and $CdMg_3$ are responsible for an increase of Young's modulus. The phase Cd_3Mg presents a special case because a variation of the axial ratios reduces the value of the modulus, but this process proceeds at a very low speed contrary to the phase formation. All alloys show a damping peak due to grain-boundary relaxation. Stress-induced changes of the ordering process are responsible for other peaks.

590. Kumai, T.,
DAMPING FACTORS IN THE HIGHER MODES OF SHIP
VIBRATION, Kyushu University, Research Institute for
Applied Mechanics, Reports, Vol. 6, 1958, pp. 25-34.

Not abstracted.

591. Kusov, A. B. and Boronovich, N. I.,
CERTAIN PECULIARITIES OF HYSTERESIS OF VULCAN-
IZED RUBBER, Kauch. i Rezina, Vol. 17, No. 2, 1958,
pp. 18-22.

On the basis of considerable experimental material it is established that the stress-strain curves during the contraction of vulcanized rubbers of different stock, mix composition, and conditions of manufacture have a similar form.

592. Lagenberg, G. and Wolff, E. G.,
THE EFFECTS OF GRAIN SIZE AND TEXTURE ON THE
INTERNAL FRICTION IN α -IRON DUE TO INTERSTITIAL
SOLUTES, Acta Metallurgica, Vol. 6, February 1958, pp.
136-137.

A redetermination shows that texture lowers internal friction and that grain size has a similar but lesser effect, and the conclusions of an earlier investigation are modified.

593. Leak, D. A. and Leak, G. M.,
SOLUBILITY AND DIFFUSION OF CARBON IN A SILICON-
IRON ALLOY, Iron and Steel Institute, Journal, July 1958,
pp. 256-262.

There is a need for data on the solubility and diffusion rate of carbon in silicon-iron transformer sheet. Internal friction measurements have been made to study this problem. Three relaxation peaks have been observed. Volume diffusion occurs by the same interstitial mechanism as is observed in alpha-iron containing carbon. Carbon atoms in solution also are associated with silicon atoms in a way similar to earlier observations on nitrogen in silicon iron. This association is less marked in the specimens containing carbon. The solubility of carbon in equilibrium with a precipitated carbide, is considerably lower than that for carbon in alpha-iron; for example, at 700° C the solubilities are about 0.005 percent by weight in iron containing 3 percent silicon and 0.02 percent by weight in alpha-iron. The carbide in the silicon iron appears to be cementite, Fe₃C.

594. Lozinskii, M. G. and Fedorovskii, A. E.,
MEASUREMENT OF MODULUS OF ELASTICITY, Izvestia
Akademii Nauk SSSR, June 1958, pp. 20-29.

This article presents a survey of dynamic methods to measure modulus of elasticity and internal friction of metals and alloys. Use is made of a specially constructed testing machine to learn temperature relation of these properties.

595. Lubahn, J. D.,
HYSTERESIS AND ANELASTICITY IN COLD-WORKED
STAINLESS STEEL, American Society for Testing Materials,
Proceedings, Preprint No. 77, 1958, 11 pp.

Creep and cyclic loading tests on cold stretched stainless steel show that the hysteresis in cyclic loading is not an anelasticity phenomenon. Practical significance of this hysteresis, as a possible source of damping, is explored.

596. Macduff, J. N. and Curreri, J. R.,
VIBRATION CONTROL, New York, New York, McGraw-
Hill Book Company, Incorporated, 1958, 465 pp.

This book presents some of the fundamentals of vibration control which are a vital part of the background

knowledge of the modern-day designer of engineering systems. Objectives are to provide basic theory and application in this area and to point out limitations of the elementary theory.

597. Marin, J. ,
MATERIALS ENGINEERING DESIGN FOR HIGH TEMPERATURE, Proceedings, Short Course Held at Pennsylvania State University, 7-11 July 1958, 418 pp.

Not abstracted.

598. Mason, W. P. ,
INTERNAL FRICTION, PLASTIC STRAIN, AND FATIGUE IN METALS AND SEMICONDUCTORS, American Society for Testing Materials, Spec. Tech. Publ. No. 237, 1958, pp. 36-50.

A new device to measure internal friction and fatigue of metals uses a BaTiO_3 transducer. The ratio of the driving voltage to the pickup voltage from the titanate and the resonant frequency permit the measurement of the internal friction and plastic strain. There are two amplitude ranges for which these properties vary with stress. Germanium is not subject to fatigue failure like a metal but suffers brittle fracture. Frank-Read dislocation loops are assumed to be cause for fatigue. Fatigue stresses can be increased by metallurgical treatment which reduces the length of the Frank-Read sources, as shown on specimens of copper, lead, and aluminum.

599. Mason, W. P. ,
PHYSICAL ACOUSTICS AND THE PROPERTIES OF SOLIDS, New York, New York, Van Nostrand, 1958, 402 pp.

It is the purpose of this book to provide an introduction to the uses of wave transmission in solids. Part I discusses types, generators and practical applications of waves in solids. Part II presents an analysis of the sources of dissipation and elastic dispersion in solids, including such subjects as the effects of thermal conductivity, sound scattering, interstitial and substitutional atom relaxations, dislocation models for low- and high-amplitude strains, and crystal lattice interactions with electrons and phonons. Numerous graphs, tables and references are included.

600. Melyakhovetskii, A. S.,
ONE HYPOTHESIS OF INTERNAL RESISTANCE TO
VIBRATIONS OF ELASTIC SYSTEM, Inzhener. Sbornik Akad.
Nauk SSSR, Vol. 26, 1958, pp. 285-286.

This paper represents the critique on Sorokin's book, Method for Taking into Consideration Nonelastic Resistances in the Investigation of Structure Vibrations (51 Sor), regarding the general expression for the internal resistance force $F = (1 + i \psi / 2\pi) S$, where S is the elastic force and ψ the damping coefficient. The article states that this general vibration composed by means of the above formula has unbounded solutions. This assertion is confirmed by one example, the case of the free vibrations of a system with one degree of freedom.

601. Mikhailov, I. G.,
THE PROBLEM OF ABSORPTION OF ULTRASONIC WAVES
IN ETHYL ACETATE, Akusticheski Zhurnal, Vol. 4, No. 2,
1958, pp. 199-200.

Two maxima are observed in the 3 to 30 mc/sec band for the ethyl acetate.

602. Miki, H.,
INVESTIGATIONS ON THE RELATION BETWEEN INTERNAL
FRICTION AND THE SCATTERING OF FATIGUE STRENGTH
OF STEEL WITH INTERNAL FLAWS, Proceedings, First
Japan Congress on Testing Materials, 1958, pp. 26-29.

Not abstracted.

603. Mima, G. and Inoue, R.,
EFFECT OF ROOM TEMPERATURE AGING UPON THE
INTERNAL FRICTION VERSUS THE COLD-WORKED
LEVELS RELATIONSHIP OF COMMERCIALY PURE POLY-
CRYSTALLINE ALUMINUM, Japanese Institute of Metals,
Journal, Vol. 22, No. 3, March 1958.

The internal friction versus the cold-working levels curve for the specimens, annealed for about 30 minutes at room temperature, before measurement, produced anomalous peaks at around 15 and 55 precipitation reductions, respectively. The first high peak decreased with annealing

time at room temperature and decayed completely after $2\frac{1}{2}$ days at room temperature. The second small peak had not decayed after a room temperature annealing for 41 days.

604. Mima, G., Inoue, R., and Tokizawa, M.,
DIFFERENCE BETWEEN THE EFFECT OF STATIC AND
IMPACT COMPRESSION ON THE INTERNAL FRICTION OF
COMMERCIALY PURE ALUMINUM, Light Metals, Tokyo,
Vol. 8, January 1958, pp. 88-92.

Internal friction decreased to a constant value upon standing at room temperature. Friction introduced by impact compression was greater than that by static compression, with an accelerated decrease of the former on standing.

605. Minnesota University, Department of Aeronautics Library,
Minneapolis, Minnesota,
DAMPING AND FATIGUE PROPERTIES OF PLASTIC
MATERIALS, APPENDIX 72 by V. W. Anderson, 1958.

The importance of material damping in controlling resonant stress and the relation of damping, elasticity, and fatigue properties to resonant fatigue strength has been discussed in prior publications. The purpose of this work was to determine the damping, elasticity and fatigue properties of materials considered for parts exposed to resonant fatigue conditions. This particular report discusses two plastics: 1) a reinforced plastic (3M crossply Scotchply) and 2) a reinforced plastic sandwich material, honeycomb type, with and without filler balls in the honeycomb cells.

606. Mišek, K.,
INTERNAL FRICTION IN NICKEL IN MAGNETIC FIELD,
Czechoslovak Journal of Physics, Vol. 8, No. 8, 1958,
pp. 129-130.

Maximum internal friction depends on the amplitude of alternating field in nickel. Lessening of internal friction is due to the fact that in presence of large amplitude the sample is in state of saturation during the entire process. This brings about lessening of interaction of alternating field and eddy current vibrations.

607. Morse, R. W., Bohm, H. V., and Gavenda, J. D.,
ELECTRON RESONANCES WITH ULTRASONIC WAVES IN
COPPER, Physical Review, Vol. 109, 1958, pp. 1394-1396.

Attenuation of longitudinal waves in copper at 1.06-4.2°K
in fields to 11,000 gauss was measured.

608. Nacken, M. and Sturies, H.,
QUENCHING AGING OF MILD, UNALLOYED STEELS,
ESPECIALLY FROM OBSERVATIONS OF THE RETROFOR-
MATION, Archiv für das Eisenhüttenwesen, Vol. 29, 1958,
pp. 235-240.

The behavior of steels in aging storage was followed by
measuring the changes with time of hardness, embrittlement,
damping property, and the reduction of carbon existing in
solution.

609. National Aeronautics and Space Administration,
EFFECT OF TEMPERATURE ON DYNAMIC MODULUS OF
ELASTICITY OF SOME STRUCTURAL ALLOYS by L. P.
Vosteen, August 1958, Report No. TN 4348, 19 pp.

The effect of temperature on Young's modulus of
elasticity was determined for 2024-T3 and 7075-T6 aluminum
alloys, AZ31A-O magnesium alloy, RS-120 titanium alloy,
and type 303 stainless steel by flexural vibration tests of
beam specimens at temperatures from room temperature to
900°F. The test frequencies were varied from 40 to 550
cps. The results are compared with values of moduli
obtained from conventional stress-strain tests. The data
show that the dynamic modulus decreases with temperature
but does not decrease as rapidly as the static modulus. It
is shown that the difference between the static modulus
and dynamic modulus is due to internal friction mechanisms,
of which anelastic effects appear to be predominant, and
cannot be attributed to creep.

610. National Advisory Committee for Aeronautics,
INTERNAL FRICTION STUDY OF ALUMINUM ALLOY
CONTAINING FOUR WEIGHT PERCENT COPPER by B. S.
Berry and A. D. Nowick, August 1958, Report No. TN 4225,
88 pp.

A study was made, by means of low frequency internal
friction measurements in both torsional and flexural

vibration, of aluminum alloy containing four percent by weight copper during aging. Both polycrystalline and single crystal specimens exhibit an initial internal friction peak at 173° C (for a frequency of one cycle per second) after solution treatment and quenching.

611. National Advisory Committee for Aeronautics,
SOME OBSERVATIONS RELATING TO RECOVERY OF
INTERNAL FRICTION DURING FATIGUE OF ALUMINUM
by S. R. Valluri, September 1958, Report No. TN 4371.

Recovery of internal friction during periods of rest in specimens subjected to fatigue stresses in torsion was studied experimentally with high purity aluminum. The idea is presented that the dislocations responsible for the recovery of internal friction are the same as those responsible for fine slip which, according to one existing theory, is the mechanism responsible for fatigue failure. Experimental results indicate that obtaining a recovery factor independent of stressing history may possibly be associated with installing a cyclic process in which the subgrain structure is well established. The basic process then occurring may be one of indefinite to and fro motion of some free dislocations within a framework of immobile arrays of dislocations responsible for the general plastic flow and the substructure.

612. National Advisory Committee for Aeronautics,
STUDY OF HYDROGEN EMBRITTLEMENT OF IRON BY
INTERNAL-FRICTION METHODS by R. E. Maringer, E. B.
Swetnam, L. L. Marsh, and G. K. Manning, September
1958, Report No. TN 4328, 62 pp.

Effects of electrolytic charging on the properties of relatively pure iron and tempered 4340 steel investigated metallographically and by observing internal friction behavior from -196° to 430° C. Electrolytic charging caused severe structural damage to both iron and steel.

613. Naumkina, N. I., Tartakovskii, B. D., and Efrussi, M. M.,
EXPERIMENTAL STUDY OF SOME VIBRATION-ABSORBING
MATERIALS, Institute of Acoustics, Academy of Sciences,
USSR, Moscow, 1958, 6 pp.

An experimental procedure is described for investigating the dynamic elastic properties of materials used for

the attenuation of vibrations which are being propagated through the metal elements of machinery and constructions. The dynamic Young's moduli and the loss coefficients of a group of synthetic materials made from a base of bitumen, reprocessed salvage rubber, and various fillers are measured. The Young's modulus for these materials ranges from 29 to 870 ksi and the corresponding loss coefficients are 0.4 to 0.1. The measurements were made in the interval of 10 to 100 cps. One of the best vibration-absorbing materials is bitumen-impregnated felt, having a Young's modulus of 14.5 ksi and a loss coefficient of 2.5.

614. Naumov, K. A.,
STABILITY OF A THIN-WALLED TUBE UNDER THE
ACTION OF A LONGITUDINAL PERIODIC FORCE WITH
CONSIDERATION FOR DAMPING, Trudi In-ta Mashinoved.
Akad. Nauk SSSR, Seminar po Teorii Mashin i Mekhanizmov,
Vol. 17, No. 68, 1958, pp. 40-50.

Axially symmetrical forms of the vibrations of a cylindrical tube are investigated; the tube is subjected to axial loading which changes periodically with time. A dissipative term is introduced into the equation; this term contains the first derivative of the transposition by time and is followed by the Matier equation with a dissipative term. The boundaries of the regions of instability for this equation are discussed.

615. Novikov, N. V.,
ON THE DISSIPATION OF ENERGY IN THE MATERIAL
DURING LONGITUDINAL-TORSIONAL VIBRATIONS OF
BEAMS, Trudi Nauchno-Tekhn. Soveshchaniya po Izuch.
Rasseyaniya Energii pri Kolebaniyakh Uprugikh Tel., Kiev,
Akad. Nauk SSSR, 1958, pp. 287-290.

Some results are given for the experimental investigation of the dissipation of energy in material, with separate and joint longitudinal and torsional vibrations of beams operating. A graph shows experimental relation of the logarithmic decrement of damping to the octahedral stress. The investigation shows that the form of the stressed state exerts a marked influence on the dissipation of energy in the material.

616. Nozdrev, V. F.,
ABSORPTION OF ULTRASONIC WAVES IN ETHYL ACETATE,
Akusticheski Zhurnal, Vol. 4, No. 2, 1958, pp. 202-204.

From a survey of recent developments in this field the author concludes that there is some doubt about many of the measurements. Work is proceeding on a multiple-radiator pulse-method which it is hoped will resolve the problem as to whether there is, or is not, a second relaxation region in acetates in the 1 to 10 mc/sec range.

617. Okazaki, N.,
TENTATIVE PROPOSAL FOR THE ORIGIN OF INTERNAL FRICTION PEAK OBSERVED IN COLD WORKED IRON,
Osaka University, Institute of Scientific and Industrial Research, Memoirs, Vol. 15, 1958, pp. 67-70.

Peak may be originated in the behavior of face-centered-cubic structure.

618. Orbeck, F.,
A STUDY OF THE SHRINK-FITTED ASSEMBLIES LOADED IN TORSION WITH SPECIAL REFERENCE TO DAMPING CAPACITY, Institution of Mechanical Engineers, Proceedings, 1959, Preprint 1958.

Not abstracted.

619. Ors, J.,
BEHAVIOR OF ULTRASONIC VIBRATIONS WHEN PENETRATING METALLIC MEDIA, Instituto del Hierro y del Acero, Vol. 11, October-December 1958, pp. 263-281.

This article presents determinations of speed of propagation of vibrations and elastic constants in gray cast iron and steels of different structures. Coefficient of damping of vibrations in iron is high due to presence of graphite.

620. Panovki, Ya. G., Gol'tzev, D. I., and Strakhov, G. N.,
ELEMENTARY PROBLEMS OF STRUCTURAL HYSTERESIS, Voprosy Dinamiki i Prochnosti V, Riga, Institute of Machine Design, Acad. Science, Latvian SSSR, 1958, p. 5.

Paper considers energy dissipation in joints.

621. Pavlov, V. A.,
STUDY OF THE DEFECTS OF A CRYSTAL LATTICE BY
MEANS OF INTERNAL FRICTION, Akademii Nauk, SSSR,
Fizika Metallov i Metallovedenie, Vol. 6, No. 1, 1958, pp.
122-127.

Pure aluminum and an aluminum-magnesium alloy (3 percent magnesium) were studied at low temperatures. Two internal friction peaks were observed over the temperature ranges from -50° to -80° C and from 170° to 180° C, together with an increase of the internal friction in the region of -196° C.

622. Pisarenko, G. S., Editor,
TRANSLATIONS OF THE SCIENTIFIC TECHNOLOGY
CONFERENCE STUDY OF DISSIPATION OF ENERGY DUR-
ING OSCILLATIONS OF ELASTIC BODIES, Akademii Nauk,
SSSR, 1958.

The effect of temperature on Young's modulus of elasticity was determined for 2024-T3 and 7075-T6 aluminum alloys, AZ31A-O magnesium alloy, RS-120 titanium alloy, and type 303 stainless steel by flexural vibration tests of beam specimens at temperatures from room temperature to 900° F. The test frequencies were varied from 40 to 550 cps. The results are compared with values of moduli obtained from conventional stress-strain tests. The data show that the dynamic modulus decreases with temperature but does not decrease as rapidly as the static modulus. It is shown that the difference between the static modulus and dynamic modulus is due to internal friction mechanisms, of which anelastic effects appear to be predominant, and cannot be attributed to creep.

623. Plenard, E.,
CONSIDERATIONS ON THE ELASTIC MODULUS AND
DAMPING CAPACITY OF GREY IRON, Centre Technique
des Industries de la Fonderie, 1958, pp. 27, 41, 166.

The elastic properties of lamellar graphitic cast iron are studied according to the stress-strain diagram. Methods used for the measurement of Young's modulus for grey iron are analyzed critically; the damping capacity of grey iron is investigated using a new method.

624. Plunkett, R.,
THE CALCULATION OF OPTIMUM CONCENTRATED
DAMPING FOR CONTINUOUS SYSTEMS, Journal of Applied
Mechanics, Vol. 25, No. 2, June 1958, pp. 219-224.

A method is presented for calculating the optimum concentrated damping for the vibration of continuous systems. It is applied to: (1) a string damped near one end, (2) a cantilever beam driven at the center and damped at the free end, (3) a uniform blade with dove-tail damping, and (4) the damped dynamic absorber. Aside from the specific results shown in the examples, there are some general conclusions. The vibration velocity and the vibratory force are not necessarily in phase at maximum amplitude for optimum damping. The decay rate at optimum damping is not necessarily related to amplification at resonance.

625. Podstrigach, Ya. S. and Chaevskii, M. I.,
THE INFLUENCE OF INTERNAL FRICTION ON THE
FATIGUE FAILURE OF CYCLICALLY DEFORMED MEM-
BERS, Soviet Physics-Doklady, Vol. 3, No. 4, July-August
1958, pp. 830-833.

During investigations of the fatigue resistance of steel samples under reversing loading in shear, the initial failure under high amplitudes of twist takes place through the formation of a great number of longitudinal surface cracks, which are then connected by transverse cracks.

Since during the testing process there appears a strong heating of the test samples (up to 300°), it is natural to suppose that their characteristic cracking is a consequence of temperature stresses. Computation of the temperature stresses appearing in the sample because of the energy dissipation also makes it possible to explain partially some other events that are observed during the fatigue failure of cyclically deformed members.

626. Podstrigach, Ya. S. and Chaevskii, M. I.,
INFLUENCE OF INTERNAL FRICTION ON THE RUPTURE
OF PARIS SUBJECT TO CYCLIC STRAIN, Doklady Akademii
Nauk SSSR, Vol. 121, No. 2, 1958, pp. 268-270.

With cyclic torsional strains, thermal stresses are caused by internal friction resulting in flaws in tangential

and axial direction. With diameter of the sample increased from 10 to 200 millimeters, the fatigue strength decreases 40 to 50 percent of the original value.

627. Polyakov, S. N. and Starodubov, V. F.,
INFLUENCE OF Mn AND Mo ON THE SOLUBILITY OF C
IN ALPHA-Fe AND THE KINETICS OF THE PROCESS OF
SEPARATION OF C FROM ALPHA-Fe IN THE PRESENCE
OF Mn AND Mo, Akademii Nauk, SSSR, Fizika Metallov i
Metallovedenie, Vol. 6, No. 6, 1958, pp. 1110-1121.

It was established that additions of 0.75 percent manganese and 0.4 percent molybdenum reduced the solubility of Carbon. Moreover, the kinetics of precipitation were radically changed.

628. Postnikov, V. S.,
CONNECTION OF THE INTERNAL FRICTION WITH THE
CREEP OF A METAL AT HIGH TEMPERATURES, Izvest.
Vysshikh Ucheb. Zavedenii, Fiz., No. 6, 1958, pp. 137-144.

A theoretical consideration is presented connecting the internal friction of a metal with its creep at high temperature, caused by the migration of lattice defects. Theoretically, the internal friction consists of three components: (1) the internal friction of a nondistorted lattice, (2) the internal friction in presence of the tensile stress, and (3) the friction caused by the lattice distortion. Preliminary laboratory measurements of torsion of nickel, Nichrome, and other alloys are in agreement with the theoretical conclusions.

629. Postnikov, V. S.,
ON THE PROBLEM OF DAMPING OSCILLATIONS OF A
CYLINDRICAL SPECIMEN, Akademii Nauk, SSSR, Fizika
Metallov i Metallovedenie, Vol. 6, No. 3, 1958, pp. 522-523.

The problem of damping of oscillations of cylindrical specimens is investigated from the point of view of the phenomenological theory of oscillations of media with plastic properties.

630. Postnikov, V. S.,
THE TEMPERATURE DEPENDENCE OF THE SHEAR
MODULUS OF CERTAIN PURE METALS, SOLID SOLUTIONS
AND ALLOYS, Akademii Nauk, SSSR, Fizika Metallov i
Metallovedenie, Vol. 6, No. 4, 1958, pp. 706-716.

The materials investigated included titanium, iron, cobalt, nickel, molybdenum and tungsten; cast and sintered alloys of the "Nimo" type and a cast Nimonic alloy, and binary solid solutions of beryllium, boron, carbon, titanium, chromium, manganese, iron, zirconium, niobium, molybdenum, and tungsten in nickel.

631. Postnikov, V. S.,
TEMPERATURE DEPENDENCE OF THE INTERNAL FRICTION OF METALS AND ALLOYS, Soviet Physics-Uspekhi, Vol. 1, September-October 1958, pp. 29-53.

The temperature dependence of internal friction is examined from both the experimental and the theoretical points of view. After stating the general thermodynamic theory of internal friction, various cases are considered (internal friction due to the ordering of atoms under stress, due to ferromagnetism, due to heat conductivity, and due to static hysteresis). A dislocation theory of internal friction is considered.

632. Postnikov, V. S.,
TEMPERATURE DEPENDENCE OF INTERNAL FRICTION IN PURE METALS AND ALLOYS, Uspekhi Jiz Nauk, Vol. 66, No. 1, 1958, pp. 43-77.

This is a review with 253 references.

633. Powers, R. W. and Doyle, M. V.,
DIFFUSION OF CARBON AND OXYGEN IN VANADIUM, Acta Metallurgica, Vol. 6, 1958, pp. 643-646.

Carbon diffuses in vanadium at a slightly more rapid rate than oxygen. From internal friction and elastic after-effect measurements, the diffusion coefficients of these interstitial impurities as functions of temperature were derived.

- .. 634. Pravdyuk, N. F., Konobeevskii, S. T., Amaev, A. D., and Pokrovskii, Ya. I.,
EFFECT OF NEUTRON IRRADIATION ON THE MECHANICAL PROPERTIES OF STRUCTURAL MATERIALS, Second United Nations International Conference on Peaceful Uses of Atomic Energy, Proceedings, Vol. 5, 1958, pp. 457-465.

The effects of temperature during pile irradiation on tensile strength was determined for austenitic stainless steel, carbon and chromium steel, zirconium, zirconium and 0.5 percent tantalum, and nickel. Experiments were conducted to determine the critical stress, at which a sharp increase in internal friction is observed in some metals before and after irradiation. The influence of plastic deformation and annealing upon internal friction was investigated along with the study of irradiation effects.

635. Radzievskii, V. A.,
FREQUENCY AND DAMPING OF THE NATURAL VIBRATIONS IN LINEAR VIBROTRANSMITTERS OF THE INERTIAL TYPE WITH LIQUID DAMPING, Doklady Akademii Nauk SSSR, Vol. 7, 1958, pp. 716-720.

Results are given of an investigation to determine the influence exercised by the connected mass of the damping liquid on the frequency and damping of the natural vibrations of vibrotransmitters.

636. Rakhstadt, A. G., Meshcherinova, O. N., and Zikeev, V. V.,
PROPERTIES AND HEAT-TREATMENT OF SPRING STEELS ALLOYED WITH BORON, Sovremennye Splavy i ikh Termichesk. Obrabotka, 1958, pp. 132-147.

Spring-steel characteristics were improved by incorporation of small quantities of boron and by adequate heat-treatment after incorporation. Elastic qualities are greatly improved with 0.003 percent boron. Boron increases the elastic limit and decreases the microplastic internal friction or increases the relaxation stability in all investigated steels; this influence may be due in part to improved deoxidation. Boron causes structural changes of the alpha-solid solution which are mainly detected after tempering by analysis, microetching, and by the maximum internal friction at 120° to 129°.

637. Robinson, P. M. and Rawlings, R.,
INTERNAL FRICTION, AN ARTICLE IN THREE PARTS,
Iron and Steel, Vol. 31, No. 1, January 1958, pp. 3-7; No. 2,
February 1958, pp. 65-68; No. 3, March 1958, pp. 97-100.

The authors review and discuss the following topics: effects of interstitial and substitutional elements; formal theory of anelasticity; measurement of internal friction; stress induced ordering of interstitial solid solutions; solubilities of carbon and nitrogen in alpha iron; diffusion coefficients; precipitation of nitrides and carbides; stress induced ordering of substitutional solutions; stress relaxation across interfaces. The bibliography includes 101 references.

638. Rosenberg, H. M.,
RESEARCH ON THE MECHANICAL PROPERTIES OF METALS
AT LIQUID-HELIUM TEMPERATURES, Metallurgical Reviews,
Vol. 3, No. 12, 1958, pp. 357-379.

Elastic moduli, work hardening, strength, brittle fracture, stress-strain relationships, creep, fatigue, and internal friction of metals at temperatures down to 4.2° K.

639. Rothenstein, B.,
RECOVERY OF INTERNAL FRICTION AFTER DEFORMA-
TION, Naturwissenschaften, Vol. 45, 1958, p. 237.

The internal friction of an annealed nickel wire was measured at room temperature with a torsion pendulum in the presence of a longitudinal alternating magnetic field (frequency, 50 cps). The maximum of internal friction as a function of the magnetic field was lower for a newly mounted wire than for the same wire 24 hours later.

640. Rothenstein, B. and Hrinca, J.,
INFLUENCE OF INTERSTITIAL CARBON (IN IRON) ON THE
MOBILITY OF BLOCH WALLS, Naturwissenschaften, Vol.
45, 1958, pp. 359-360.

Wire of Swedish iron was held two hours at 600° in vacuo and water-quenched to retain carbon in solution. Internal friction measurements showed a peak which was decreased in magnitude and shifted to lower temperature by aging up to 1.5 hours at 200°. Internal friction was then measured in a longitudinal alternating magnetic field at various field

strengths at room temperature and at 200°, and the results were compared with those measured without magnetic fields. The difference in internal friction at a given temperature thus determined, when plotted against field strength, exhibits a maximum. This maximum difference is increased by the aging treatment above, which indicates that mobility of Bloch walls is increased by a decrease in dissolved carbon.

641. Royal Aircraft Establishment, Great Britain,
NOTE ON MATERIAL AND STRUCTURAL DAMPING by
P. B. Walker, November 1958, Report No. Structures 243.

This report is concerned with the collection and analysis of existing data on material damping, and the consideration of the overall damping of a complex structure such as a monoplane wing. Tables giving the material damping of simple test specimens are compiled from the work of various investigators. This information is then considered in relation to a complex structure, and the additional factors which contribute to the overall damping are discussed. The damping of a test specimen appears to depend, not only on the nature of the material, but also on the dimensions of the specimen and the mode of oscillation. In certain types of structure, of which a conventional metal wing is an outstanding example, material damping accounts for only a small proportion of the total damping of the system. This report is a reproduction without alteration of a report issued in 1936.

642. Rudnick, I.,
ON THE ATTENUATION OF HIGH AMPLITUDE WAVES OF
STABLE SAW-TOOTH FORM PROPAGATED IN HORNS,
Acoustical Society of America, Journal, Vol. 30, No. 4,
April 1958, pp. 339-342.

The attenuation is studied theoretically. The shock associated with each wave is assumed to be weak. An expression for the power loss for a generalized horn is obtained.

643. Rozhanskii, V. N. and Dekartova, N. V.,
THE RELATIONSHIPS IN THE DAMPING OF TORSIONAL
OSCILLATIONS OF METAL WIRES, Soviet Physics-Doklady,
Vol. 3, No. 4, 1958, pp. 838-841.

The authors tested zinc and copper wire specimens at large strain amplitudes and found that the logarithmic decrement diminished with time. The present paper describes an attempt to discover the fundamental equations of motion from experimental data, as well as the operative relationships governing the damping of oscillations for finite amplitudes. They consider the differential equation and obtain a solution after determining the functions $\lambda(t)$

$$\phi + \phi \psi(t) + \phi \lambda(t) = 0$$

and $\psi(t)$ from experimental data. They suggest that the next step should be to let ψ and λ be functions of both t and ϕ .

644. Rozhanskii, V. N. and Dekartova, N. V.,
ON THE PHENOMENOLOGY OF DAMPING OF TORSIONAL
OSCILLATIONS IN METAL WIRES, Doklady Akademii Nauk,
SSSR, Vol. 121, No. 2, 1958, pp. 274-276.

The authors suggest that the apparent time-dependence of damping constant and frequency during the decay of free oscillations can be satisfactorily ascribed to a first-order dependence on amplitude alone. They used zinc and copper wires.

645. Salen, F. M. and Yousef, Y. L.,
ELASTICITY AND INTERNAL FRICTION OF BISMUTH,
Proceedings, Mathematical Society of Egypt, No. 22, June
1958, pp. 143-154.

Young's modulus, E , and the internal friction, Q^{-1} , were studied by a transverse vibration method at low sonic frequencies in three varieties of annealed bismuth, namely: the monocrystalline, the polycrystalline, and the ductile metal. It was found that, in the temperature interval -80° to 200° C, the variation in Q^{-1} , though very pronounced in the low temperature region, is rather slight between 20° and 200° C, being in general a mild increase with evidence of a small relaxation peak in ductile and in polycrystalline specimens, possibly due to enhanced grain boundary diffusion, having an activation energy of about 15 kilocalories per mole

in both. Strong strain amplitude dependence of E and Q is noticed in the strain range of 10 and is correlated with dislocation mobility.

646. Samoilova, A. Ya. and Postnikov, V. S.,
THE RECOVERY OF INTERNAL FRICTION OF ALUMINUM,
SILVER, AND PLATINUM AFTER THE REMOVAL OF THE
LOAD, Akademii Nauk, SSSR, Fizika Metallov i
Metallovedenie, Vol. 6, No. 6, 1958, pp. 1081-1087 (Physics
of Metals and Metallography, Vol. 6, No. 6, 1958, pp. 124-
129, English Translation).

The phenomenon of internal-friction recovery of aluminum, silver, and platinum was studied after small deformations by low-frequency vibrations ($\nu = 1$ cps) of low amplitude. Values were obtained for the heat of activation of the process of the internal-friction recovery for these metals equal to 4500, 6400, and 8000 calories per mole, respectively.

647. Sazhin, B. I., Lobanov, A. M., and Gol'denberg, A. L.,
Sarminskaya, T. N., Marakhonov, I. A., and Kabin, S. P.,
PROPERTIES OF POLYETHYLENE SUBJECTED TO THE
ACTION OF γ - RADIATION, Soviet Physics-Technical
Physics, Vol. 3, 1958, pp. 1828-1834.

The investigation of polyethylene subjected to the action of γ - radiation from a Co^{60} source showed that the observed variations in the structure of macromoles, revealed by infrared spectroscopy, are reflected in the variation of the temperature dependence of tangent δ of dielectric and mechanical losses.

648. Schiller, P.,
MECHANICAL RELAXATION IN PURE SINGLE CRYSTALS
OF ICE, Zeitschrift für Physik, Vol. 153, 1958, pp. 1-15.

The mechanical relaxation in single crystals of ice was investigated between zero and -100° in the frequency range of 800 to 6000 cps by means of the characteristic oscillations of combined resonators.

649. Schlagel, A.,
MEASUREMENTS OF MODULUS OF ELASTICITY AND LOSS
FACTOR FOR SOLID MATERIALS, Bruel and Kjaer Tech.
Rev., Vol. 1, 1958 (Vol. 4, 1957).

Not abstracted.

650. Seemann, H. J. and Dickenscheid, W.,
THE EFFECT OF GRAIN SIZE ON SNOEK DAMPING AND
THE AGING OF CARBON FERRITE, Acta Metallurgica,
Vol. 6, No. 1, 1958, pp. 62-63.

The authors discuss the relationship between carbon content and the Snoek damping peak.

651. Shermergor, T. D.,
ON THE THEORY OF RELAXATIONAL PHENOMENA IN
SOLID BODIES, Akademii Nauk, SSSR, Fizika Metallov i
Metallovedenie, Vol. 6, No. 6, 1958, pp. 1077-1080.

Theoretical investigations of relaxation of stresses and deformations in solids are usually generalizations of Hooke's law or use is made so the Boltzmann theory of elastic after-effects or thermodynamics of nonequilibrium processes. The thermodynamic method is the most general. It was applied herein to calculated stress tensor for a nonuniform isotropic unbounded solid. It is shown that, in general, the dynamic values of elastic moduli are determined by a spectrum of relaxation times.

652. Shmatov, V. T.,
INTERNAL FRICTION AND THE ABSORPTION OF SOUND
IN SYSTEMS WITH ADDITIONAL INTERNAL PARAMETERS,
Akademii Nauk, SSSR, Fizika Metallov i Metallovedenie,
Vol. 6, No. 6, 1958, pp. 984-993 (Physics of Metals and
Metallography, Vol. 6, No. 6, 1958, pp. 984-993, English
Translation).

Formulae are derived for the value of internal friction, the velocity and coefficient of absorption of sound in systems with one or several additional internal parameters. Near the point of phase transition of the second kind (if it is caused by the existence of an additional internal parameter) a connection is established between the jumps of elastic moduli and the value of internal friction and the connection between

the jump in the square of the velocity and the value for the coefficient of absorption of sound. The internal friction and absorption of sound near the Curie point are maxima.

653. Shvidkovskii, E. G. and Durgaryan, A. A. ,
THE RELATION OF INTERNAL FRICTION AND YOUNG'S
MODULUS TO TEMPERATURE, IN SOME METALS,
Nauchnye Doklady Vvsshei Shkoly, Fiz. Mat. Nauki, No. 5,
1958, pp. 211-216.

The relation of internal friction and Young's modulus to temperature is studied by a resonance method for bismuth, tin, cadmium, zinc, and lead. From the curves of internal friction-temperature, relaxation maximum are found at 170° for polycrystalline lead, -50° for polycrystalline cadmium, 265° for polycrystalline zinc, and 150° for non-annealed monocrystalline zinc. No maximum is found for annealed monocrystalline zinc.

654. Shvidkovskii, E. G. and Durgaryan, A. A. ,
THE RELATION OF INTERNAL FRICTION AND RIGIDITY
MODULUS TO THE AMPLITUDE OF OSCILLATIONS AND
COLD-WORKING IN SOME METALS, Nauchnye Doklady
Vvsshei Shkoly, Fiz. Mat. Nauki, No. 5, 1958, pp. 217-222.

Mono- and polycrystals of tin and cadmium, monocrys-
tals of bismuth polycrystals of zinc, and electrolytic copper,
are studied by a resonance method in a frequency range from
40 to 120 kilocycles.

655. Shyne, J. C. ,
STRESS-INDUCED ORDERING INTERNAL FRICTION OF
IRON-ALUMINUM ALLOYS, Dissertation Abstracts, Vol.
19, 1958, p. 1333 (University Microfilms, L. C. Card No.
Mic 58-7788, 135 pp.).

An experimental program has been carried out for the
purpose of investigating the stress-induced ordering inter-
nal friction of iron-rich alloys of iron and aluminum. The
relaxation strength was very small below 10 atomic percent
aluminum but increased rapidly from 10 to 19 atomic percent.
Beyond 19 atomic percent aluminum, the relaxation strength
was decreased by the long-range order, which was most
nearly perfect at 25 atomic percent aluminum. At that com-
position, Fe_3Al , the relaxation strength reached a minimum

and increased slightly as the aluminum content was further increased to 31.3 atomic percent. It was concluded from the data that a high degree of short-range order existed below 10 atomic percent and that the Fe₃Al superlattice was not perfect because of thermal disorder.

656. Simon, G. ,
THE DAMPING OF ELASTIC WAVES OF HIGH FREQUENCY
IN CUBIC FERROMAGNETIC SINGLE CRYSTALS, Annals of
Physics, Vol. 1, No. 7, 1958, pp. 23-35.

Damping at high frequency is attributed to reversible displacements of Bloch walls, and rotation of magnetization vectors. This effect is calculated as a function of the material constant and experimental variables. The damping attains a maximum when the penetration of the exciting high-frequency waves, limited by the skin effect, is comparable to the elastic wave length. This applies to a single-domain sample; if there are many domains, there is a further maximum at lower frequencies, for which the penetration is comparable with domain dimensions. The theory is compatible with published data, but no complete test of the theory proved possible.

657. Singh, B. R. and Pearce, C. E. ,
ON DAMPING IN VIBRATION, Institute of Engineers (India),
Journal, Vol. 38, No. 5, 1958, pp. 519-532.

Not abstracted.

658. Sinnott, K. M. ,
APPARATUS FOR MEASUREMENT OF SHEAR MODULUS
AND INTERNAL FRICTION BETWEEN 4.2 AND 100 K,
Journal of Applied Physics, Vol. 29, 1958, pp. 1433-1437.

The apparatus consists of a small torsion pendulum suspended on a rigid support at the bottom of a large glass Dewar vessel. After cooling to 4.2° K with liquid helium, the pendulum warms up at an initial rate of 0.1 degree per minute. Torsional oscillations of the pendulum are excited electrically and recorded photographically. Measurements of the shear modulus and logarithmic decrement have been made, from 4.2° to 100° K, on a series of tetrafluoroethylene-hexafluoropropylene copolymers.

659. Skowronski, J. ,
LINEAR DAMPING OF A SINGLE IMPULSE BY A NON-
LINEAR SHOCK ABSORBING SYSTEM, Rozpr. Insyn. , Vol.
6, No. 1, 1958, pp. 121-141.

A motor car with its spring and pneumatic tires represents a complicated vibrating system. A computation of such a system is difficult in view of a considerable number of degrees of freedom and the requirements concerning the accuracy of calculation. The author has chosen the most important part of motor car vibration, limiting the considerations to a system of one degree of freedom with one wheel, a linear damping element and a nonlinear elastic element. The paper is intended to furnish practical directions for designers. It contains an analysis of the requirements and a description of several computational methods.

660. Snowden, J. C. ,
THE CHOICE OF RESILIENT MATERIALS FOR ANTIVIBRATION MOUNTINGS, British Journal of Applied Physics, Vol.
9, No. 12, December 1958, pp. 461-469.

The criteria are defined for a good antivibration mount material, solely from the aspect of vibration reduction. Such a material should possess a high damping factor which does not increase greatly with frequency, and be free from any major increase in dynamic modulus with frequency. Filled butyl rubber affords an isolation at high frequencies not greatly inferior to that of natural rubber, yet at the same time possessing much higher damping.

661. Solov'ev, V. A. ,
DYNAMIC VISCOELASTIC PROPERTIES OF LOW-PRESSURE POLYETHYLENE, Vestnik Leningrad University, Vol. 13,
No. 4, Ser. Fiz. i Khim. , No. 1, 1958, pp. 30-35.

The dynamic Young's modulus and internal friction in several samples of high-pressure and of low-pressure polyethylene are measured by the composite piezoelectric resonator method. Curves are given for the temperature dependence of sound velocity, acoustical reactance, dynamic viscosity, and logarithmic decrement at 75 kc/sec from -160° to approximately the melting point.

662. Solov'ev, V. A.,
USE OF A COMPOSITE PIEZOELECTRIC VIBRATOR TO
STUDY THE MECHANICAL PROPERTIES OF POLYMERS,
Trudy Seminara po Fiz. i Primeneniyu Ul'trazvuka,
Posvyachch. Pamyati Prof. S. Ya. Sokolova, Leningrad,
1958, pp. 168-172.

A method for measuring Young's modulus and internal friction in polymers is described.

663. Sosin, A., Bienvenue, L. and Schlein, H.,
INTERNAL FRICTION MEASUREMENTS, Review of
Scientific Instruments, Vol. 29, 1958, pp. 657-659.

A device for measuring damping in the low kilocycle range is described.

664. Southgate, P. D.,
TEMPERATURE DEPENDENCE OF INTERNAL FRICTION
IN GERMANIUM, Physical Review, Vol. 110, 15 May 1958,
pp. 857-885.

Measurement of the internal friction of germanium as a function of temperature at 100 kc/sec is discussed. There is a peak at 420° C and little further rise to within a few degrees of the melting point. A specimen strained in tension shows a rapid rise with temperature above 500° C. These results are compared with those of Kessler and it is suggested that the high-temperature rise found in all his specimens is due to thermal stressing. A small peak at 770° C is attributed to the presence of oxygen in the germanium.

665. Stark, P., Averbach, B. L., and Cohen, M.,
INFLUENCE OF MICROSTRUCTURE ON THE CARBON
DAMPING PEAK IN IRON-CARBON ALLOYS, Acta
Metallurgica, Vol. 6, 1958, pp. 149-155.

The internal-friction peak due to the stress-induced migration of carbon in body-centered cubic iron was studied in a series of high-purity iron-carbon alloys with variations in grain size and intercarbide distance. It was found that when these microstructural parameters are small the height of the carbon damping peak does not correspond to the equilibrium solubility as the solutionizing temperature.

666. Starodubov, K. F. and Polyakov, S. N.,
THE SOLUBILITY OF CARBON IN ALPHA-IRON, WHICH
IS ALLOYED WITH MANGANESE AND MOLYBDENUM, AND
THE KINETICS OF THE SEGREGATION OF SUCH CARBON
FROM THE SOLUTION, Dopovidi Akad. Nauk Ukr. R. S. R.,
No. 2, 1958, pp. 135-138.

The method of internal friction was used to investigate the behavior of carbon in alpha-iron which contained manganese 0.75 percent and molybdenum 0.40 percent. The manganese and the molybdenum lower the solubility of the carbon in the alpha-iron. The molybdenum-containing iron, if tempered at 550° to 650°, shows the formation of a stable carbide; the carbon becomes then almost insoluble as such in alpha-iron. These results explain why one observes a reversible high-temperature tempering brittleness, in such manganese-molybdenum alloyed iron.

667. Steinberg, M. S.,
RESONANT ABSORPTION OF SOUND IN METALS, Physical Review, Vol. 110, No. 6, 15 June 1958, pp. 1467-1469.

The variation of ultrasonic attenuation with strength of applied magnetic field is examined in this article. A derivation is given of the resonance rules inferred by Morse, Bohm, and Gavenda from their experiments on copper.

668. Steinberg, M. S.,
VISCOSITY OF THE ELECTRON GAS IN METALS, Physical Review, Vol. 109, 1958, pp. 1486-1492.

Coefficient of shear viscosity of free electron gas interacting with thermal phonons and local crystal nonhomogeneities is computed for aiding the explanation of ultrasonic attenuation in metals.

669. Stephens, R. W. B.,
THE APPLICATIONS OF DAMPING CAPACITY FOR
INVESTIGATING THE STRUCTURE OF SOLIDS, Progress in Non-Destructive Testing, Vol. 1, 1958, pp. 167-198.

The rate of loss of vibrational energy of a solid is a measure of its damping capacity, or internal friction. Recent applications of this to the investigation of the structure of solids are reviewed. The article discusses methods

of measuring damping capacity, anelasticity, the effect of experimental conditions, and the cause of damping. Phenomena which can be studied by these methods include annealing, plasticity, phase transformations, fatigue, effects of irradiation, solid-liquid transitions and crystallinity, diffusion effects, and effects at very low temperatures. The applications of damping capacity measurements of semiconductors, ferroelectrics and ferromagnetics, ferrites, ionic crystals, and glass-like materials are considered.

670. Strakhov, G.,
CHARACTERISTICS OF DAMPING IN A TWO-LEAF SPRING,
Izv. Akad. Nauk Latv SSR, Vol. 9, 1958, pp. 117-124.

The magnitude of the decrement of damping of the vibrating structure is determined by the sum total effect of friction in the joints of the union and the friction in the metal itself. The more significant of the two is the friction in the joints. The simplest problem of all is investigated, the determination of the decrement of damping in the spring, consisting of two leaves connected at the ends by a friction link. A hysteresis loop is drawn and a determination is made of the dissipation of energy for a single cycle in relation to the spring's characteristics to the link's union. The experiments with a model are furnished to confirm the correctness of the calculation.

671. Sumner, G. and Entwistle, K. M.,
THE MEASUREMENT OF THE STRAIN-DEPENDENT DAMPING OF METALS VIBRATING TORSIONALLY, British Journal of Applied Physics, Vol. 9, No. 11, November 1958, pp. 434-438.

Apparatus is described for the measurement at room temperature of the mechanical damping of torsionally vibrating metal specimens up to shear strains of about 2×10^{-3} for mild steel. Values obtained for an aluminum alloy agree with the decrement measured by a free-decay test to about one percent.

672. Sutherland, R. L.,
ENGINEERING SYSTEMS ANALYSIS, Reading, Massachusetts, Addison-Wesley Publishing Company, Incorporated, 1958, 223 pp.

The definition and interpretation of engineering analogies are introduced, and the dynamical analogies of resonance in

mechanical, electrical, and acoustical systems are analyzed. One technique employed in the solution of dynamical systems are analyzed. One technique employed in the solution of dynamical system problems is the generalized or dimensionless ratio approach which is useful in many engineering problems. Application to dynamical systems is a natural introduction to the study of dimensional analysis, which is found to be a powerful aid in studying many physical problems.

673. Takeda, T.,
FATIGUE (CREEP) OF HIGH POLYMERS, Oyo Butsuri,
Vol. 27, 1958, pp. 290-294.

The energy absorbed by a polymer rod by cyclic (10 to 40 cps) stress variations of tension and compression/cycle/unit volume was measured by a resonance method. The vibration fatigue was derived from the experimental energy values. The measurements with polyethylene showed that log of the rate of energy absorption increases linearly with log of the static rate of creep.

674. Tamhankar, R., Plateau, J., and Crussard, C.,
STUDY OF HOT PLASTIC DEFORMATION OF A SOFT IRON
AND A STABLE NICKEL-CHROMIUM AUSTENITE, Revue
de Métallurgie, Vol. 55, April 1958, pp. 383-400.

Mechanical properties and structural modifications accompanying deformation at high temperature studied by tension, torsion, creep, and internal friction tests.

675. Thompson, D. O., Glass, F. M.,
ELASTIC CONSTANT --INTERNAL FRICTION SPECTRO-
METER, Review of Scientific Instruments, Vol. 29, No. 11,
November 1958.

The essential feature of the spectrometer is that it holds the sample in oscillations at its resonance frequency and at a preset strain amplitude, and measures the internal friction of the sample through a measurement of the driving force necessary to maintain the preset amplitude.

676. Troost, A.,
DETERMINATION OF DAMPING CAPACITY, Industrie-
Anzeiger, May 1958, pp. 21-23.

Not abstracted.

677. Truell, R. and Bayer, R.,
EVIDENCE FOR DISLOCATION BREAKAWAY IN PURE
ALUMINUM, Physical Review, Vol. 110, No. 5, June 1958,
pp. 1206-1207.

Acoustic attenuation and velocity measurements made on specimens of aluminum during deformation give evidence about the size and changes in size of dislocation loop lengths as well as dislocation density changes in the material. Pure aluminum in almost single crystal form, tested while subjected to tension, gave a very rapid increase in acoustic attenuation at low strains (below 0.02 percent), and this attenuation was much greater than that obtained with commercially pure material.

678. Truell, R., deKlerk, J., and Levy, P. W.,
NEUTRON IRRADIATION EFFECTS IN BOROSILICATE
GLASS AND THEIR DETECTION BY ULTRASONIC ATTENU-
ATION AND VELOCITY MEASUREMENTS, Journal of Applied
Physics, Vol. 29, No. 2, February 1958, pp. 225-226.

Irradiation of under one-hour duration in the Brookhaven reactor produces attenuation and velocity changes. After longer irradiations, the glass samples invariably cracked and eventually fell to pieces.

679. Tsukamoto, S., Kanazawa, K., and Motoyama, M.,
ATTENUATION OF SUPERSONIC WAVES IN STEEL PLATES
BY SEGREGATION BANDS, Suiyokaishi, Vol. 13, 1958, pp.
483-486.

Steel specimens which have segregation bands caused by high contents of sulfur (maximum 0.2 percent), or phosphorus (maximum 0.04 percent), were investigated by the attenuation of supersonic waves (five megacycles). The attenuation of supersonic waves was found to be caused by the segregation band of sulfide and silicates, but not by segregation of phosphorus.

680. United States Department of Agriculture, Forest Products Laboratory,
AN APPARATUS FOR MEASURING INTERNAL FRICTION AND FATIGUE STRENGTH OF CORE MATERIALS USED IN SANDWICH CONSTRUCTION, October 1958, Progress Report No. 1866.

Apparatus and techniques are described for measuring the energy absorbed by sandwich core materials subjected to rapidly cycled shear stress. Exploratory data are given on three commercial aluminum honeycomb cores with foil thicknesses of 0.002, 0.003, and 0.004 inch.

681. Vodsedalek, J. and Stefer, R.,
THE EFFECT OF NITRIDING ON THE INTERNAL FRICTION OF STEEL, Hutnické Listy, Vol. 13, No. 1, 1958, pp. 9-13.

The authors have tried to show the nature of damping in current steels, and the way in which damping is influenced by external conditions. Nitriding is in most cases accompanied by a slight decrease of damping, but this decrease during bending and torsion stresses is exceeded by the simultaneous increase of the fatigue stress.

682. Vedeneeva, M. A. and Tomashov, N. D.,
THE ALTERATION OF INTERNAL FRICTION AND FREQUENCY OF SELF-VIBRATION DURING THE INTERCRYSTALLINE CORROSION OF THE STAINLESS CHROMIUM-NICKEL STEEL, Proizvodstvo i Obrabotka Stali i Splavov, Moskov. Inst. Stali im. I. V. Stalina, Sbornik, Vol. 38, 1958, pp. 483-494.

The authors' purpose was to explain the possibility of determining intercrystalline corrosion by measurement of internal friction. A series of stainless steels of the type 18/9 containing 0.018 to 0.23 percent carbon with or without molybdenum or titanium addition were investigated. The intercrystalline corrosion of specimens was achieved by boiling them in 110 grams of $\text{CuSO}_4 \cdot 5\text{H}_2\text{O}$ and 55 cubic centimeters of H_2SO_4 in one liter of water. The extent of intercrystalline corrosion before and after treatment was evaluated by measuring electric resistivity, internal friction, and tensile strength. It was revealed that internal friction characterized only intercrystalline failure, while measurement

of electric resistivity and frequency of self-vibration indicated the total effect of corrosion process.

683. Vidyakin, Yu A.,
THE DAMPING CAPACITY OF THE BLADES OF A STEAM
TURBINE UNITED IN A BLOCK BY MEANS OF A BAND,
Energomashinostroenie, Vol. 11, 1958, pp. 12-15.

Eight blocks were examined, differing from each other in the number of blades, structural details of the band, etc. The results of the experimental investigation are given in the form of the relation of the vibration decrement to the stresses in the root section of the blade.

684. Wachtman, J. B., Jr. and Tefft, W. E.,
EFFECT OF SUSPENSION POSITION ON APPARENT
VALUES OF INTERNAL FRICTION DETERMINED BY
FORSTER'S METHOD, Review of Scientific Instruments,
Vol. 29, No. 6, June 1958, pp. 517-520.

Values of internal friction determined by Forster's method may be in error by an order of magnitude if the effect of suspension damping is not eliminated. The effect of suspension damping on measured values of internal friction as a function of suspension position was calculated. The calculated results were compared with experimental results and found to describe the variation correctly.

685. Weigand, A.,
DAMPED VIBRATION OF A HOMOGENEOUS CHAIN,
Zeitschrift für Angewandte Mathematik und Mechanik, Vol.
38, No. 1/2, January-February 1958, pp. 28-39.

Author considers viscously damped longitudinal vibrations of a homogeneous chain consisting of n equal masses connected with one another by identical springs and dampers. By expressing the complex eigenvalues in trigonometric form, solutions are obtained in closed form for a system of difference equations of motion for free vibration and for forced vibration under harmonic force or displacement excitation. By means of Laplace transformations, the transient state is further solved, and, in particular, the effect of rectangular impulse is discussed.

686. Weissmann, G. F. and Babington, W.,
HIGH-DAMPING MAGNESIUM ALLOY FOR MISSILE APPLI-
CATIONS, American Society for Testing Materials, Pro-
ceedings, Vol. 58, 1958, pp. 869-886 (Discussion pp. 887-
892).

A technique utilizing simple vibration tests of canti-
lever beams to calculate the specific damping capacity (SDC)
of a material was developed. Damping studies were conducted
on several experimental magnesium alloys containing 0.2 to
1.0 percent zirconium, and on two compound magnesium
alloys. The magnesium alloy containing 0.6 percent zirco-
nium (designated K1X1) showed a very high SDC combined
with adequate mechanical properties.

687. Welber, B. and Quimby, S. L.,
ADIABATIC YOUNG'S MODULUS AND INTERNAL FRICTION
OF SUPERCONDUCTING LEAD AND TIN, Acta Metallurgica,
Vol. 6, No. 5, May 1958, pp. 351-359.

Measurements are reported of the Young's modulus and
coefficient of internal friction of polycrystalline lead and tin
in the normal and superconducting states, and of the variation
of these quantities with temperature and strain amplitude.
An upper limit is assigned to the existence of a discontinuity
in the Young's modulus at the critical temperature. The
results are discussed from the viewpoint of the thermo-
dynamics of the superconducting transition.

688. Wieckowski, J.,
THE INFLUENCE OF MATERIAL DAMPING ON THE NON-
CONSERVATIVE REACTIONS OF ELASTIC BEAMS DURING
TORSIONAL AND LONGITUDINAL VIBRATIONS, Arch. Mech.
Stos., Vol. 10, No. 4, 1958, pp. 479-497.

The stress waves due to forced vibration provoke, in an
elastic medium, reactions depending on the type of external
force and the elastic and geometrical quantities of the system.
These reactions have the character of viscous friction forces
and, therefore, they are nonservative with constant coef-
ficient λ . The influence of material damping on the values
and properties of these reactions in the case of longitudinal
vibration of beams and coil springs are taken into considera-
tion. For torsional vibration of an infinite beam, an

approximate equation is obtained for the coefficient λ , material damping being taken into consideration, its influence in this case being significant.

689. Wojtczak, J.,
THE DEPENDENCE OF THE COEFFICIENT OF INTERNAL FRICTION ON TEMPERATURE, Wiadomosci Chem., Vol. 12, 1958, pp. 13-29.

The various mathematical means of describing the temperature-dependence of internal friction are reviewed.

690. Wright Air Development Center, Wright-Patterson Air Force Base, Ohio, DAMPING ENERGY DISSIPATED BY INTERFACES IN BEAM AND PLATE SUPPORTS AND IN SANDWICH CORES by T. J. Mentel, December 1958, Report No. TR 58-547.

The maximum energy dissipation which can result from both viscous and dry friction damping between the longitudinal interfaces at the supports of built-in beams and plates is compared with the total material damping. This comparison shows that this type of support damping is relatively unimportant in the vibration attenuation problem for beams, but may be extremely important in the case of thin plates. An alternative method for the damping of beams, that of using sandwich construction with an energy dissipating central core, is found to provide an effective damping mechanism in the cases where support damping becomes ineffective.

691. Wright Air Development Center, Wright-Patterson Air Force Base, Ohio,
DAMPING PROPERTIES OF A CAST MAGNESIUM AND A MANGANESE COPPER ALLOY PROPOSED AS HIGH DAMPING MATERIALS by P. Torvik, December 1958, Status Report 58-4, Contract AF-33 (616)-2803, Appendix, 72 figures.

The rotating beam test method was used to obtain fatigue and damping data for CDC Manganese Copper Alloy 780. The alloy was found to have not only good damping properties but also relatively high fatigue strength, thus placing it very favorably among structural materials which are resistant to resonant fatigue. The decay of free vibrations method was used to obtain damping data for a cast magnesium alloy. This alloy displays a very high damping on a stress basis, but its

fatigue strength is probably low; thus, a high rating on a fatigue basis can not be assumed in the absence of fatigue data.

692. Wright Air Development Center, Wright-Patterson Air Force Base, Ohio,
ENERGY DISSIPATION IN LONGITUDINAL VIBRATION by
C. S. Chang and L. E. Goodman, July 1958, Report No.
TR 58-36, ASTIA Document No. 155705.

The problem of the longitudinal vibrations in a finite prismatic bar with a terminal viscous damper is solved. The complete boundary value problem (forced vibration with arbitrary initial conditions) is first split into two parts according to the method developed by Mindlin and Goodman. One of these parts yields the steady-state solution and the other represents a free-vibration problem, which is then solved by the method of Boussinesq.

693. Wu, T. L. and Wang, C. M.,
MECHANISM OF CARBON DIFFUSION PEAK IN FACE-CENTERED IRON-NICKEL ALLOYS, Wu Li Hsuch Pao,
Vol. 14, 1958, pp. 354-368.

At a vibrational frequency of 1.4 cps, an internal friction peak is observed at about 500° K. It is postulated that this peak arises from the preferential rotation of the axes of carbon pairs. Since the quenched-in vacancies aren't likely to disappear at low temperature and the number of carbon pairs may be taken to be the equilibrium value at all temperatures, a quantity relation between the peak height and the carbon concentration can be derived. Thus, it is possible to determine the heat of formation of a substitutional carbon atom from the interaction between an interstitial carbon atom and a vacancy.

694. Yakovlev, A. P.,
THE INFLUENCE EXERTED BY THE FORM OF THE VIBRATIONS ON THE DISSIPATION OF ENERGY IN THE MATERIAL, Trudi Nauchno. - Tekhn. Soveshchaniya po Izuch. Rasseyaniya Energii pri Kolebaniyakh Uprugikh Tel., Kiev, Akad. Nauk SSSR, 1958, pp. 228-246.

The procedure is described and the results given for the investigation of the dissipation of energy in a material (the logarithmic decrement δ) during the higher forms of

transverse vibrations of prismatic beams. A description follows of two experimental sets of apparatus; one of these was used to excite successively the first four forms of vibrations for cantilever beams; the second, the first two forms of vibrations for beams with free ends. In all the cases, the initial maximum stresses were identical and approximate the endurance limit ($\sim 15 \text{ Mg/mm}^2$). The results of the investigation given in graphs, showing the relation of the logarithmic decrement δ to the maximum normal stress σ for all the tested materials, indicate the significant lowering of δ with increase in the tone of the vibrations at equal stresses for σ . The fact is also noted of the inappreciably small influence exerted on δ by the frequency of the vibrations and loss due to friction of the air.

695. Zener, C.,
ANELASTICITY OF METALS, Nuovo Cimento, Supplement,
Vol. 7, Series 10, No. 2, 1958, pp. 545-568.

The author presents the formal theory of anelasticity and points out that anelastic behavior is a manifestation of the existence of certain parameters in the generalized Hooke's law. These parameters lead to thermal relaxation, grain boundary relaxation, electron relaxation and relaxation due to interstitial solute atoms. Each of these can be studied through internal friction measurements.

696. Air Force Office of Scientific Research,
INTERNAL FRICTION STUDY OF COLD-WORKED IRON
CONTAINING NITROGEN by D. Petarra, April 1959, Report
No. TN 59-270, AD-212704, PB 142004, 31 pp.

A mechanism explaining the complex behavior of the 200° C peak height as a function of annealing temperature is advanced. The recovery process directly affects the height of the 220° C internal friction peak and indirectly the height of the room temperature peak. The relationship is brought out.

697. American Society for Testing Materials, 1916 Race Street,
Philadelphia, Pennsylvania,
SYMPOSIUM ON BASIC MECHANISMS OF FATIGUE, 1959.

These proceedings include discussions of dislocation behavior in LiF crystals during cyclic loading, fatigue crack formation in AgCl, internal friction, plastic strain, and fatigue in metals and semiconductors, slip band formation and fatigue cracks under alternating stress, cycle-dependent stress relaxation, and recent observations on fatigue failure in metals.

698. Amonenko, V. M., Shapoval, B. I., and Lebedev, V. V.,
TEMPERATURE RELATION BETWEEN INTERNAL FRICTION AND THE ELASTIC CONSTANTS OF PURE IRON,
Akademii Nauk, SSSR, Metallov i Metallovedenie, Vol. 2,
1959, pp. 249-254.

The relation for pure iron (99.99 percent) is similar to that for other metals, but the absolute values for all temperatures investigated are higher by a small factor than for Armco iron. Not all the carbon contained in the pure iron is present in the solid solution. Between 20° and 700° there exists an almost linear relation between the modulus of elasticity and the shear modulus.

699. Andres, H.,
A METHOD OF MEASURING THE COMPLEX DYNAMIC
ELASTIC MODULUS, Hochfrequenztechnik und Elektro-
akustik, Vol. 67, No. 6, 1959, pp. 174-180.

A description is given of a system for measuring the elasticity and loss factor of materials over a wide range of frequencies (20 to 300 cps). The materials tested were various types of foam rubber and pure rubber. In the latter case, a number of resonance frequencies were observed.

700. Aoki, K., Sekino, S., and Fujishima, T.,
ON THE MEASUREMENT OF INTERSTITIAL C AND N
CONTENT, AND THE STRAIN-AMPLITUDE DEPENDENCE
OF INTERNAL FRICTION IN COMMERCIAL STEELS,
Japanese Institute of Metals, Journal, Vol. 23, December
1959, pp. 696-698.

An apparatus for measuring internal friction of square bars vibrating transversely in the range 16 to 20×10^3 cps detects interstitial carbon and nitrogen contents down to 10^{-6} percent by weight in low-carbon steels. Results are given for rolled pure iron and annealed aluminum-killed deep-drawing steel. The strain-amplitude of internal friction was also measured for both specimens.

701. Armstrong Cork Company, Lancaster, Pennsylvania,
Armstrong Felt and Fiber Products, 1959.

A variety of asphalt-saturated vibration-damping felts for use on metal panels are described. Characteristics, properties, and specifications are given. A typical felt can be used from zero to 180° F with high damping efficiency at moderately high temperatures.

702. Atomic Energy Commission,
THEORY OF RELAXATION PHENOMENA IN SOLIDS by
B. N. Finkel'shtein and N. S. Fastov, 1959, Report No.
13-20360.

This article presents a theory of relaxation in solids formed on the basis of general thermodynamic considerations analogous to those brought forward in the theory of sound absorption in liquids.

703. Avraamov, Y. S. and Mezhennaya, S. O.,
STUDY OF Ni₃Mn-BASE ALLOY BY THE METHOD OF
INTERNAL FRICTION, Nauchnye Doklady Vyshei Shkoly,
Met., No. 2, 1959, pp. 189-193.

The study of ordering by means of internal friction, Q , of an alloy with components the atomic diameters of which differed little, was of interest. Ni₃-Mn-base alloy, containing nickel 75.10 percent and manganese 22.80 percent, was chosen as a representative of this group of alloys. The plots of Q versus the temperature exhibited two wide (order) peaks, A and B, at 120° and 290°. Deformations, 75 percent, resulted in an additional peak, D, at 226°.

704. Babaeo, N. N.,
ON THE INFLUENCE OF INTERNAL, INELASTIC RESIS-
TANCE FORCES ON FORCES TRANSVERSE VIBRATIONS
OF BEAMS, Akademiya Nauk SSSR, Otdeleniye Tekhnicheskikh
Nauk, Izvestiya, No. 7, July 1959, pp. 125-129.

A nonprismatic bar with free end is considered. The damping force is assumed to be proportional to the velocity. Calculations are carried out with a view toward applications for ship hull vibration.

705. Battelle Memorial Institute, Columbus, Ohio,
THE EFFECTS OF SOLUTE ELEMENTS ON MAGNETO-
ELASTIC DAMPING AND COERCIVITY IN VERY PURE
IRON by R. E. Maringer and G. K. Manning, 1959, Report
No. OTS PB 149,865, 22 pp.

Data are presented showing the time and temperature dependence of the damping in zone-melted iron containing small amounts of carbon. Measurements of the temperature dependence of the induced voltage in a transformer-type apparatus have revealed a sigmoidal increase in the induced voltage with increasing temperature. This increase is apparently related to the temperature-dependent increase in magnetoelastic damping, and calculated relaxation times indicate that the interstitial diffusion of carbon is responsible.

706. Belov, K. P., Kataev, G. I., and Levitin, R. Z.,
INTERNAL FRICTION AND ELASTICITY MODULUS IN
FERROMAGNETIC MATERIALS NEAR THE CURIE POINT,
Zhurnal Eksperimental'noi i Teoreticheskoi Fiziki, Vol. 37,
1959, pp. 938-943.

The temperature dependence of the Young modulus and of internal friction near the Curie point of elinvar (iron-nickel-chromium), coelinvar (iron-cobalt-chromium) alloys, nickel and nickel-zinc ferrite was measured. Jumps of the Young modulus in the Curie point are shown for alloys containing nickel 36 percent, chromium 12 percent, iron 52 percent, and nickel 33.1 percent, chromium 1.9 percent, and iron 59.5 percent which have a large magnetostriction of the para process. The first alloy also has a sharp maximum of internal friction. An alloy containing cobalt 53.5 percent, chromium 8.7 percent, and iron 37.8 percent has a still sharper maximum. Nickel and nickel-zinc ferrite do not show anomalies, which are attributed, therefore, to a redistribution of spins in the domains. A thermodynamic theory is developed for these phenomena.

707. Berry, B. S.,
THE ROLE OF VACANCIES IN AN UNUSUAL ANELASTIC
PHENOMENON, Acta Metallurgica, Vol. 7, No. 11, November
1959, pp. 741-745.

The internal-friction results obtained by Entwistle from a number of quench-aging aluminum alloys are re-examined and interpreted. Two transient contributions to the internal friction are observed on aging duralumin near room temperature. The observed sequence of changes indicates that the relaxation centers responsible for both contributions occur within the Guinier-Preston zones, and that a spontaneous reorganization within the zones is responsible for the change-over from one contribution to the other.

708. Beshers, D. N.,
INTERNAL FRICTION OF COPPER AND COPPER ALLOYS,
Journal of Applied Physics, Vol. 30, No. 2, February 1959,
pp. 252-258.

A systematic experimental study was made of the effect of adding small amounts of gold to copper on the dislocation damping in copper measured at 37 kc/sec in longitudinal

resonance. The results have been classified in terms of the dependence of the damping on strain amplitude and time with temperature and composition as parameters.

709. Biondi, M. A. and Garfunkel, M. P.,
MILLIMETER WAVE ABSORPTION IN SUPERCONDUCTING
ALUMINUM. I. TEMPERATURE DEPENDENCE OF THE
ENERGY, Physical Review, Vol. 116, 15 November 1959,
pp. 853-861.

Measurements of the temperature dependence of the microwave absorption in superconducting aluminum in the wavelength region 20 to 3 millimeters are reported. The results show that, at a well-defined energy for each temperature, there is a rapid rise in absorption with increasing energy. This has been interpreted as the onset of absorption resulting from direct excitation of electrons across a forbidden energy gap. The isotherms then permit the determination of the temperature dependence of this energy gap.

710. Biondi, M. A. and Garfunkel, M. P.,
MILLIMETER WAVE ABSORPTION IN SUPERCONDUCTING
ALUMINUM. II. CALCULATION OF THE SKIN DEPTH,
Physical Review, Vol. 116, 15 November 1959, pp. 862-867.

The skin depth in superconducting aluminum is calculated from the measured frequency dependence of the surface resistance through the Kronig-Kramers integral transforms. At absolute zero, it is found that the skin depth is independent of frequency at low frequencies, but begins to increase at higher frequencies. The skin depth increase rate goes through a maximum for equal energies of the gap and photons. The skin depth has a peak at kT_c .

711. Bisshopp, K. E.,
FORCED TORSIONAL VIBRATION OF SYSTEMS WITH
DISTRIBUTED MASS INTERNAL AND EXTERNAL DAMP-
ING, Journal of Applied Mechanics, Vol. 26, No. 1, March
1959, pp. 8-12.

This analysis extends similar results previously obtained in a paper by Den Hartog and Li, where the remainder torque is calculated at one end of a homogeneous system.

Comparative computations made here with complex Holzer tables show excellent agreement with results obtained from the theory of distributed systems.

712. Blount, E. I.,
ULTRASONIC ATTENUATION BY ELECTRONS IN METALS,
Physical Review, Vol. 114, No. 2, April 1959, pp. 418-436.

The calculation of ultrasonic attenuation is discussed for arbitrary frequency and band structure. The results are applied to the cases of a metal with a spherical energy surface and a semimetal with electrons in two "valleys". Possible experimental uses are pointed out. The occurrence of saturation is discussed. The acoustoelectric effect is also treated by similar methods and is seen to be closely related to the attenuation.

713. Bode, E.,
THE VARIATION IN INTERNAL FRICTION IN SILVER,
Zeitschrift für Naturforschung, Vol. 14a, No. 8, August 1959, pp. 762-763 (In German).

A torsion pendulum was used to test silver specimens at 203° C and at a frequency of 0.2 cps. That part of the internal friction dependent on amplitude, Q_A^{-1} , was determined from the measurements made after deflection to a specific amplitude measured on the circumference of the twisted wire. Q_A^{-1} initially did not vary with the maximum torque up to a certain limiting value, beyond which it increased markedly with torque. When plotted in the form of $\log Q_A^{-1}$ versus the maximum torque employed in each test, it gave curves similar in form to those obtained by Granato and Lücke, but not nearly so steep. It was deduced from this that only about five percent of the change of damping with torque was due to parallel slip.

714. Bömmel, H. E. and Dransfeld, K.,
ATTENUATION OF HYPERSONIC WAVES IN QUARTZ,
Physical Review Letters, Vol. 2, 1959, pp. 298-299.

Quartz acoustic absorption for 4.2° K room temperature was measured at 1000-4000 mc/sec.

715. Bordoni, P. G., Barducci, I., and Nuovo, M.,
RESEARCH ON THE PHYSICS OF SOLIDS BY ULTRASONICS
TECHNIQUES, Met. Ital., Vol. 51, November 1959, pp. 525-
526.

Research obtained at the National Research Institute for Ultrasonics are discussed. These techniques enable exact measurements to be made of variations in elastic and inelastic parameters of solids due to temperature and speed of thermoelastic transformation. Five types of study are carried out: (1) dependence of elastic and inelastic parameters on temperature and frequency, (2) study of metal alloy, (3) effect of impurities, (4) effect of magnetic fields, and (5) porous metals.

716. Bordoni, P. G., Nuovo, M., and Verdini, L.,
RELAXATION OF DISLOCATIONS IN COPPER, Nuovo
Cimento, Vol. 14, No. 2, 1959, pp. 273-314.

The frequency and attenuation of standing waves were measured in polycrystalline copper at 1.8×10^3 - 6.5×10^6 cps between 60° and 300° K. The activation energy and the limiting frequency associated with the attenuation peak due to dislocations were found to be 0.122 electron volts per mole and 2.89×10^{12} cps, respectively, in agreement with the values obtained from recent theories. The shape of the attenuation/temperature curves showed that the spectrum of relaxation frequencies was a bell-shaped line. The attenuation and frequency relaxation were both reduced by heat treatment at temperatures up to 500° K. Treatments at higher temperatures gave comparatively large changes in attenuation and frequency which did not seem to be directly related to pre-existing dislocations.

717. Boswell, F. W. C.,
THE EFFECT OF DEFORMATION ON THE INTERNAL
FRICTION OF IRON MEASURED AT THE CARBON PEAK
POSITION, Canadian Journal of Physics, Vol. 37, No. 12,
December 1959, pp. 1474-1481.

Experiments have been carried out to investigate the influence of deformation on the internal friction of iron measured at the carbon peak. As a result of deformation, the internal friction increased and then decreased with time.

These changes, corrected for a background change associated with the deformation, were shown to follow a time law predicted for carbon segregation to dislocations. It is concluded that the amount of carbon in random solid solutions is increased by the deformation. By analyzing the rate of decrease of internal friction following deformation in terms of strain-aging theory, the final dislocation densities were determined. The results also indicate that in some cases the carbon put into solution by the deformation was initially present in the form of iron-carbide particles.

718. Bratina, W. J.,
INVESTIGATION OF DEFORMATION PROCESSES IN ARMCO IRON BY MEANS OF INTERNAL FRICTION AT MEGACYCLE FREQUENCIES, Canadian Journal of Physics, Vol. 37, 1959, pp. 579-590.

Internal friction, with frequencies in the megacycle range, was used to study the characteristics of elastic and plastic deformation in Armco iron. Tensile stresses only were applied. A decrease in ultrasonic attenuation at external static stresses within the elastic range, which appears to be related to the ordering effect of the stress on magnetic domains, was investigated. An initial increase in attenuation values regularly observed in cold-worked specimens on the application of an external load was associated with the internal stresses.

719. Brown University, Providence, Rhode Island,
THE EFFECT OF COBALT-60 γ -RAY IRRADIATION ON ULTRASONIC ATTENUATION AND VELOCITY IN NaCl AND KCl by A. V. Granato, N. G. Einspruch, L. J. Teutonico, P. C. Waterman, B. B. Chick, R. Truell, and P. W. Levy, 1959, Report No. TID-5597, 38 pp.

The effect of Co^{60} γ - rays on ultrasonic attenuation in NaCl in the 10 to 200 megacycle range was studied. The measurements were made on both compressional and shear wave propagation in the [100] direction of both NaCl and other alkali halides.

720. Brown University, Metals Research Laboratory, Providence, Rhode Island,

THE USE OF ULTRASONIC METHODS TO DETERMINE FATIGUE EFFECTS IN METALS by R. Truell, November 1959, Report No. OTS PB 161487, 24 pp.

High-frequency ultrasonic attenuation and velocity measurements were used to investigate physical changes in aluminum and other metals during stress cycling. Automatic attenuation equipment was developed to record attenuation changes during long-term experiments.

721. Bruner, L. J.,
INTERNAL FRICTION IN IRON AT LOW TEMPERATURES, Physical Review Letters, Vol. 3, 1959, pp. 411-412.

Internal friction of swaged and annealed vacuum-melted and swaged zone-refined iron and extended copper were measured at 25 kc/sec and 4.2° to 350° K.

722. Cabaret, R.,
RESULTS OBTAINED WITH AN ELECTROSTATICALLY EXCITED EXTENSOMETER, Mémoires Scientifiques de la Revue de Métallurgie, Vol. 56, 1959, pp. 144-150.

The method for measurement of the elastic modulus and damping capacity is based on the possibility of maintaining longitudinal vibrations in the specimen by electrostatic excitation. The apparatus measures the frequency and amplitude of the vibrations up to 800°. The logarithmic decrement was measured during the solid-state transformations of aluminum-copper alloys and steel alloys containing carbon 2.3 to 2.41 percent, silicon 1.28 to 1.59 percent, manganese 0.36 to 0.48 percent, sulfur 0 to 0.13 percent, phosphorus 0.08 to 0.11 percent.

723. Caughey, T. K.,
CLASSICAL NORMAL MODES IN DAMPED LINEAR DYNAMIC SYSTEMS, American Society of Mechanical Engineers, Proceedings, No. 59-A-62, 1959.

An analysis of the condition under which a damped linear system possesses classical normal modes is presented. It is shown that a necessary and sufficient condition for the existence of classical normal modes is that the damping matrix be diagonalized by the same transformation.

724. Chang, R.,
HIGH TEMPERATURE CREEP AND ANELASTIC PHENOMENA IN POLYCRYSTALLINE REFRACTORY OXIDES,
Journal of Nuclear Materials, July 1959, pp. 174-181.

Creep in Al_2O_3 and BeO were studied and activation energies derived. The effects of small additions of Cr_2O_3 or La_2O_3 to Al_2O_3 and of MgO to BeO in improving high temperature ductility are discussed.

725. Chaudhuri, K. D.,
ULTRASONIC ATTENUATION OF METALS AT LOW TEMPERATURES, Zeitschrift für Physik, Vol. 155, 1959, pp. 290-295.

At very low temperatures when the mean free path of the electrons in metals becomes large but less than the wave length of sound, a relation exists between electronic conductivity and the attenuation of sound. It is shown that a similar relation can be derived between thermal conductivity and sound which fits the experimental data better.

726. Chesapeake Instrument Company, Shadyside, Maryland,
DYNAMIC MECHANICAL PROPERTIES OF PLASTIC MATERIALS by E. R. Fitzgerald, J. W. Fitzgerald, and A. E. Woodward, June 1959, Contract No. NObs-72100.

Article discusses viscoelastic wave propagation and concepts of complex moduli and compliances; data on several materials over wide temperature and frequency ranges are given.

727. Ch'ien, C.,
MECHANISM OF INTERNAL-FRICTION PEAK OF INTERSTITIAL ATOMS IN FACE-CENTERED CUBIC CRYSTALS,
Chin Shu Hsüeh Pao, Vol. 4, 1959, pp. 69-74.

An internal-friction peak was found for carbon in nickel (1 cps frequency, near 300° , up to 0.52 percent by weight carbon, quenched from 1300° , an external magnetic field applied to reduce the background friction at temperatures below the Curie point). A log-log plot of the peak versus the concentration showed that the peak was proportional to the square of the concentration of carbon. On the other hand,

the peak in a manganese steel (18.5 percent by weight manganese) was linear with the concentration of carbon (oxygen at about 0.2 percent carbon). The former mechanism was probably the rotation of a carbon-carbon pair (neighboring interstitials) and the latter the rotation of a carbon manganese pair.

728. Chih-Hung, C., Tsun, K., and Lin-Chao, T.,
DEVELOPMENT OF METAL PHYSICS AND PHYSICS OF
METALLURGY IN THE CHINESE PEOPLES' REPUBLIC
DURING TEN YEARS, Akademii Nauk SSSR, Fizika Metallov
i Metallovedenie, Vol. 8, No. 6, 1959, pp. 16-23.

Seventy papers by Chinese authors are reviewed under four categories of investigation: physics of strength and plastic deformation of metals; internal friction and diffusion; phase transitions; and theory of metals and alloys. For the most part, these papers appear in readily available sources.

The main emphasis of the papers on internal friction seems to be on the presence and magnitude of internal friction peaks as a function of microstructure.

729. Chikov, E. A.,
TRANSVERSE OSCILLATIONS OF RODS TAKING ACCOUNT
OF DAMPING UNDER THE ACTION OF LONGITUDINAL
AND TRANSVERSE PERIODIC LOADS, 17th Nauchn.
Konferentsis, Leningrad, 1959, pp. 16-19.

The question of the influence of resistive forces on the transverse oscillation and dynamic stability of rods supported by hinges at the ends and subjected to the simultaneous action of longitudinal and transverse periodic forces is considered. The differential equation for the generalized coordinate is established by the use of the Lagrange equation: the general solution is found by expanding the unknown function in a sine or cosine type of series in terms of the small parameter. The nature of the influence of the resistive forces on the amplitude of forced oscillations and on the phenomenon of dynamic stability is established.

730. Cochardt, A.,
MAGNETOMECHANICAL DAMPING, Magnetic Properties of Metals and Alloys, Proceedings, American Society for Metals, 1959, pp. 251-279.

This paper investigates magnetic domain patterns under stress, magnetomechanical stress-strain hysteresis loops, delta-E effect and magnetomechanical hysteresis damping, and the relation between hysteresis damping and magnetic properties. Also discussed are the effects of frequency, magnetic field, static stress, cold working, heat treatment, amplitude of vibration, chemical composition, and temperature and stress system on hysteresis damping; and damping due to microscopic and macroscopic eddy current.

731. Cochardt, A.,
THE USE OF THE MAGNETOMECHANICAL EFFECT FOR [COBALT-NICKEL] ALLOYS OF HIGH DAMPING CAPACITY AND HIGH STRENGTH, Zeitschrift Metallkunde, Vol. 50, No. 4, 1959, pp. 203-206.

The unusually high damping capacity of the current chromium alloy steel - chromium 12 percent, nickel 0.5 percent, and carbon 0.1 percent - used for steam-turbine blades is attributable to magnetomechanical hysteresis. Examination of 55 binary and ternary alloys, based on iron, chromium, nickel, and cobalt, led to the development of "NIVCO", a cobalt-base alloy containing 35 percent nickel and small amounts of other elements. Its properties at 650° C are similar to those of the current material at 500° C; it has a high irreversible magnetostriction, with excellent hardness and oxidation-resistance; its matrix has a face-centered cubic structure; it is ferromagnetic up to at least 800° C.

732. Cornell University, Ithaca, New York,
AN EXPERIMENTAL STUDY OF MECHANICAL AND DIELECTRIC LOSSES IN CERTAIN HIGH POLYMERS by H. S. Sack, H. Vardhan, T. J. Wood, and T. R. Cuykendall, 1959, OTS AD Report No. 144, 405, 46 pp.

Second-order transitions in pure polyvinyl acetate, pure and plasticized cellulose acetate, and pure, plasticized, plasticized and stabilized, and plasticized and cross-linked cellulose nitrate were studied by using both mechanical and dielectric loss measurements. In the study of mechanical

losses, the main effort was designed to permit measurements down to about 10^{-4} cps. Temperatures as low as -200° were used in some cases.

733. Crandall, S. H.,
RANDOM VIBRATION, Cambridge, Massachusetts and New York, New York, Technology Press of Massachusetts Institute of Technology and John Wiley and Sons, Incorporated, 1959, 423 pp.

The new concepts required to extend ordinary vibration theory into the field of random vibration are described, and a broad picture is given of the current state of the art of designing and testing equipment which must withstand random vibration. The book divides naturally into two parts. The first six chapters treat basic concepts and background material while the last six chapters apply directly to the problems of design and testing. The chapter on structural damping is primarily a review of previously published articles.

734. Dabosi, F., Migaud, B., and Talbot, J.,
COMPARISONS BETWEEN DAMPING OF ELECTROLYTIC AND ZONE-REFINED IRON, Comptes Rendus, Vol. 248, No. 4, 1959, pp. 444-553.

Internal friction studies were carried out on three helium annealed iron wires; zone-refined, electrolytic, and Armcotype. Where grain sizes were comparable, the purest samples showed distinctly high damping.

735. Datsko, O. I.,
CHANGES IN THE CHARACTER OF GRAIN BOUNDARIES OF NICKEL CAUSED BY ALLOYING WITH COPPER, Trudy Inst. Fiz. Metal., Akad. Nauk SSSR, Ural. Filial, No. 22, 1959, pp. 117-121.

Relaxation phenomena and relative moduli of elasticity of vacuum-melted nickel and its alloys containing 10, 20, and 40 percent by weight copper were determined by internal friction, by using a torsional pendulum. Oscillation frequency was about 0.5 cps. Nickel annealed three hours at 900° showed internal friction peaks at 420° to 440° and 700° to 760° . Alloys treated similarly showed negligible internal friction to about 500° , followed by sharp monotomic crises.

Internal friction of nickel and alloys reached a maximum at 700° to 900°. Nickel showed a marked decrease in internal friction, with an inflection at about 750°.

736. Dekhtyar, I. Ya., and Mikhalenkov, V. S.,
INVESTIGATION OF THE MOBILITY OF ATOMS IN NICKEL
ALLOYS BY THE METHOD OF INTERNAL FRICTION,
Issledovaniya po Zharoproch. Splavam, Akad. Nauk SSSR,
Inst. Met. im. A. A. Baikova, Vol. 4, 1959, pp. 188-192.

A study was made of the recovery of internal friction in nickel alloys containing 5, 15, and 20 percent molybdenum. The time required for complete recovery of internal friction depends on temperature in a similar way to that of the time of relaxation. The energy of activation for all investigated alloys was about nine kilocalories per mole.

737. De Klerk, J.,
ULTRASONIC WAVE PROPAGATION IN A NICKEL SINGLE
CRYSTAL, Physical Society, Proceedings, London, Vol. 73,
1959, pp. 337-344.

The propagation of ultrasonic energy in a nickel single crystal by an improved pulse technique was used to investigate the behavior of the dynamic elastic constants of, and the energy losses in, the specimen with and without an applied magnetic field.

738. Dickson, E. W.,
THE INTERNAL FRICTION OF BERYLLIUM AT 30 kc/sec,
Microcards NP-8996, 1959.

Not abstracted.

739. Dickson, E. W. and Strauch, H.,
APPARATUS FOR THE MEASUREMENT OF INTERNAL
FRICTION AND DYNAMIC YOUNG'S MODULUS AT KILO-
CYCLE FREQUENCIES, Journal of Scientific Instruments,
Vol. 36, No. 10, 1959, pp. 425-428.

Electrostatic transducers are used to excite and detect longitudinal vibrations in a rod specimen clamped at its midpoint. Oscillations in the associated circuitry are at the resonance frequency of the specimen. The amplitude of the

specimen oscillations may be calculated. Internal friction and Young's modulus are measured as functions of strain amplitude and temperature up to 500° C.

740. Dickson, E. W. and Thorley, N.,
CONSTRUCTION OF A SENSITIVE TEMPERATURE CONTROLLED TORSIONAL PENDULUM, Proceedings, Univ. Durham Phil. Soc. A, Vol. 13, No. 11, 1959, pp. 98-107.

The vertical tubular furnace and its temperature control system, and the housing and constructional details of the pendulum, are fully described and illustrated. The frequency of oscillation of the pendulum was 0.3 cps, and the torsional deflection of the inertia arm was measured by means of an optical lever. Some preliminary experimental results of measurements of the modulus of rigidity and internal friction of the wire specimens are given and discussed.

741. Dobbs, E. R., Chick, B. B., and Truell, R.,
ATTENUATION OF SOUND IN A GERMANIUM CRYSTAL AT ULTRAHIGH FREQUENCIES AND LOW TEMPERATURES, Physical Review Letters, Vol. 3, 1959, pp. 332-334.

Ultrasonic attenuation of compressional and shear waves at frequencies to 650 mc/sec was determined in germanium for temperatures down to 1.5° K.

742. Dow Chemical Company, Magnesium Department, Midland, Michigan,
HIGH DAMPING CHARACTERISTICS OF MAGNESIUM, 1959, Bulletin No. 141-194.

This article is a discussion of the virtues of a new alloy, KIA, developed by the Dow Chemical Company. A comparison of damping, in logarithmic decrement units, of KIA to that of pure magnesium, cast iron, alloy EZ33A, and between that of sand-cast and die-cast KIA is given.

743. Drutowski, R. C.,
ENERGY LOSSES OF BALLS ROLLING ON PLATES, Journal of Basic Engineering, Vol. 1, No. 2, Series D., June 1959, pp. 223-239.

The apparatus for measuring the rolling force of a ball supported between two plates is described. The rolling force

is an extremely small quantity compared to the normal force. Instantaneous values of the rolling force vary greatly from point to point on the sample surface and this variation is explained in terms of surface roughness and material homogeneity. The energy losses of balls rolling on plates are shown as functions of load, material, and surface roughness. The rolling of a ball on a plate is examined as a cyclic process in which elastic hysteresis losses appear to be the primary source of energy dissipation. An analysis involving the Hertzian contact stress field is used to derive an equation relating the rolling force and the material damping capacity.

744. Dyer, I.,
RESPONSE OF PLATES TO A DECAYING AND CONVECTING
RANDOM PRESSURE FIELD, Acoustical Society of America,
Journal, Vol. 31, No. 7, July 1959, pp. 922-928.

Following the methods of Lyon, an analysis of the vibratory response of a plate to a random pressure field is given. It is shown that damping is usually, but not always, an effective means of vibration reduction. In the case of convection speeds much smaller than the flexural speed, the use of hysteretic damping for reduction of the displacement response is shown to be limited by the decay of the assumed random pressure field.

745. Eder, F. X. and Haefner, H.,
ELECTROMAGNETIC TORSION APPARATUS MEASURES
INTERNAL DAMPING OF METALS, Experimentelle Technik
der Physik, Vol. 7, 1959, pp. 280-286.

The novel features of the apparatus are: (1) the sample becomes excited to perform pure sinusoidal oscillations, (2) the frequency is varied from 1 to 10^{-4} cps, and (3) the amplitude is changeable. Measurements on solutions of carbon and nitrogen in alpha-iron at zero to 100° agree well with theory and previous measurements. Samples of AlMg 1 chilled from 300° show two relaxation maxima.

746. Eischen, G.,
EFFECT OF ADSORBED GASES ON THE TORSIONAL
ELASTICITY OF GLASS FIBERS, Comptes Rendus, Vol. 248,
1959, pp. 3160-3162.

The torsional elasticity of glass fibers, 18 to 42μ diameter, has been investigated in atmospheres of helium, neon,

argon, krypton, and ChCl_3 . At constant temperature, the torsional elasticity depends on the nature of the gas adsorbed on the surface of the fiber.

747. Eisele, F. and Drumm, H.,
EFFECT OF WELDING ON THE RIGIDITY AND DAMPING
PROPERTY OF STRUCTURAL STEEL, Schweissen und
Schneiden, Vol. 11, 1959, pp. 75-83.

Damping measurements and static rigidity tests were carried out on welded I beams. The experimental values were found to be lower than those for seam- and spot-welded beams. Damping values were influenced by the size and type of the weld.

748. Entwistle, K. M.,
MEASUREMENTS OF DAMPING CAPACITY IN THE STUDY
OF FATIGUE IN FERROMAGNETIC MATERIALS, Revue de
Métallurgie, Vol. 56, July 1959, pp. 224-230.

Measurements of nickel and several steels of a peak of magnetic origin in the curve representing the relationship between damping capacity and vibrational strain, showed that the alternating strain for the damping value corresponding to the peak is of the order of magnitude of the mean internal strain of the specimens examined, in accordance with the domain theory.

749. Favstov, Yu. K.,
APPARATUS FOR THE DETERMINATION OF INTERNAL
FRICTION IN METALS, Zavodskaya Laboratoria, Vol. 5,
1959, pp. 606-608.

Construction details are given for a pendulum similar to that of Foepfel and Pertz. Results are given for several steels.

750. Favstov, Yu. K.,
THE EFFECT OF HEAT TREATMENT AND PLASTIC
DEFORMATION ON INTERNAL FRICTION IN METALS,
Fiz. tverdogo Tela, Vol. 1, No. 3, March 1959, pp. 499-
508.

Experiments carried out on aluminum and two types of steel (0.11 percent and 0.56 percent carbon) showed that

both the logarithmic decrement, δ_0 , and a coefficient, K, describing the amplitude dependence of δ_0 , were affected by thermal treatment (annealing, hardening, tempering, aging) and plastic deformation.

751. Filson, D. H.,
LOW TEMPERATURE ULTRASONIC ATTENUATION IN
TIN AND ALUMINUM, Physical Review, Vol. 115, 1959,
pp. 1516-1519.

For ideal metal, attenuation should be linear with electronic conductivity and quadratic with frequency. Theoretical and experimental values were compared for 0.1 to 1.0 mc/sec. A long-wire sample coupled to a BaTiO₃ transducer was suspended in a chamber in a liquid-helium bath: electronic conductivity and amplitude of successive reflections versus temperature and frequency for short trains of sine waves were determined. Tin behaves as in theory. For aluminum, attenuation was proportional to conductivity, but was 45 percent higher than predicted.

752. Folweiler, R. C. and Brotzen, F. R.,
THE EFFECT OF QUENCHED-IN VACANCIES ON THE
ELASTIC MODULUS OF ALUMINUM, Acta Metallurgica,
Vol. 7, No. 11, November 1959, pp. 716-721.

Equipment for the dynamic measurement of modulus changes was developed. The presence of lattice vacancies was found to reduce the elastic modulus. The change in modulus was investigated during annealing at room temperature subsequent to quenching. The time relation of vacancy concentration observed was analogous to that determined by electrical-resistivity measurements.

753. Galkin, A. A. and Korolyuk, A. P.,
ANISOTROPY OF ULTRASOUND ABSORPTION IN METALS
IN A MAGNETIC FIELD, Zhurnal Eksperimental'noi i
Teoreticheskoi Fiziki, Vol. 36, 1959, pp. 1307-1309.

Absorption was measured on single crystals at tin and zinc at 7.3, 23.3, and 70 megacycles. In a perpendicular magnetic field maxima appear which are increased when the temperature is decreased to 2° K or when the frequency is increased. Rotation of the magnetic field changes the maxima. The observed phenomena are attributed to diffraction scattering of electrons in the lattice.

754. Garber, R. I. and Kovalev, A. I.,
DETERMINATION OF THE PERIOD OF RELAXATION AT
THE POLYMORPHIC TRANSFORMATION OF IRON, Akademii
Nauk, SSSR, Fizika Metallov i Metallovedenie, Vol. 8, 1959,
pp. 785-788.

In the temperature range of 20° to 1000°, measurements have been made of the damping ratio of torsional vibrations in cylindrical specimens of technical iron with a carbon content of 0.04 percent.

755. Garber, R. I. and Saloshenko, I. I.,
STRENGTHENING OF ROCK SALT CRYSTALS BY REPEATED
FLEXING AT SMALL AMPLITUDES, Nekotorye Problemy
Prochnosti Tverd. Tela, Shornik Stati, 1959, pp. 105-110.

An apparatus was described for determining the decrement of frequency damping of samples in a manner practically independent of elastic properties. The decrement in burnt rock salt was $(7.8 \pm 0.2) \times 10^{-4}$, and its value was unaffected by dissolution of the surface layer with H₂O.

756. Gebhardt, E., Seghezzi, H. D., and Durrschnabel, W.,
NEW INVESTIGATION OF THE TANTALUM-NITROGEN
SYSTEM, Plansee Proceedings - 1958, High Melting Metals,
Metallwerk Plansee AG., Reutte/Tyrol, Austria, 1959,
pp. 291-302 (In German).

This paper investigates: (1) phases developing in tantalum wire and strip exposed to nitrogen at 10⁻³ to 10⁻² millimeters, mercury pressure and 1600° to 2000° C temperature; (2) electrical resistivity, hardness, and temperature-dependent internal friction as functions of the nitrogen content; and (3) effects of nitrides precipitated on the grain boundaries, and therefore of the grain size, on internal friction.

757. General Electric Company, Schenectady, New York,
MEASUREMENT OF DAMPING by R. Plunkett, July 1959,
Report No. R59GL:77, AD-606-421, 25 pp.

Not abstracted.

758. Giles, G. G.,
EFFECT OF HYSTERESIS OF RUBBER ON ITS RESISTANCE
TO SLIPPING, Rubber Journal and International Plastics,
Vol. 136, No. 25, 1959, pp. 947-948 (I. F. C., International
Tire Symposium, Paris, 20-22 May 1959).

Wet surfaces only were dealt with, and the relation between hysteresis loss and friction and the effect of temperature were considered. The latter differs from surface to surface. As the hysteresis losses rise with temperature, the friction increases. The same effect might be obtained by using a rubber of high hysteresis. Slipping in wet conditions causes damage to the rubber well below its surface, this is because of heat developed by hysteresis. There is not much difference in frictional properties between smooth and patterned tires on two different surfaces, but there is a difference when rubbers of high hysteresis are used.

759. Gobrecht, H. and Bartschat, A.,
THE EFFECT OF THE ACTIVATOR AND THE STORAGE
OF RADIANT ENERGY ON THE PIEZOELECTRIC AND
ELASTIC BEHAVIOR OF CdS SINGLE CRYSTALS,
Zeitschrift für Physik, Vol. 153, No. 5, 1959, pp. 529-554.

The mechanical damping of the thickness vibration of CdS plate crystals was measured by utilizing the piezoelectric effect. The damping was measured at the temperatures of 20° and -180° C as a function of illumination, using both visible and infrared radiation. A variety of crystals was investigated, including very pure specimens which showed little photoconductivity, highly activated, sensitive crystals and intermediate samples. The results show a close correlation between the state of activation of a crystal and its mechanical damping and also an interaction between illumination and damping.

760. Grin, A. V.,
INFLUENCE OF CONDITIONS OF RECRYSTALLIZATION
ON INTERNAL FRICTION IN METALS AND ALLOYS, Trudy
Inst. Fiz. Metal., Akad. Nauk SSSR, Ural. Filial, Vol. 22,
1959, pp. 101-106.

The dependence of internal friction on temperature is investigated at zero to 500° for aluminum and aluminum-0.5 percent magnesium subjected to diverse conditions of

heat-treatment. For pure aluminum, and to a lesser extent for aluminum-0.5 percent magnesium, maximum internal friction depends on rate of temperature change during recrystallization.

761. Hashiguchi, R. and Okuda, S.,
INTERNAL FRICTION OF COLD-WORKED GOLD AND
COPPER AT LOW TEMPERATURES, Proceedings, Japan
Academy, Vol. 35, 1959, pp. 284-288.

The specimens used were polycrystalline wires of gold 99.999 percent and copper 99.99 percent pure. The specimen was annealed and fixed in the apparatus, then deformed at room temperature or at liquid nitrogen temperature. The effects of quenching were compared with those of plastic deformation. The three peaks of internal friction, appearing in respective annealing stages after plastic deformation, are common for gold and copper specimens.

762. Hasiguti, R. R. and Okuda, S.,
INTERNAL FRICTION OF COLD WORKED GOLD AND COP-
PER AND LOW TEMPERATURES, Institute of Physical and
Chemical Research, Scientific Papers, Japan, Vol. 53,
December 1959, pp. 265-270.

Inverted torsion pendulum method measures internal friction of gold and copper from -180° to 80° C when deformed. Theory based on point defect-dislocation interaction is proposed to explain three peaks appearing in the internal friction versus temperature curve during annealing.

763. Hawkes, F. C.,
PRECIPITATION-HARDENING ELINVAR, Journal of Applied
Physics, Vol. 30, 1959, pp. 206S-207S.

In a nickel-iron-chromium alloy of the elinvar type containing 2.5 percent titanium, it is possible to retain the titanium in solid solution by a quench from 1000° . Aging at 600° produces a nonmagnetic precipitate of an intermetallic compound (Ni_3Ti) dispersed throughout the ferromagnetic matrix. The internal friction, Curie point, and coercive force were measured during the course of precipitation. The effect of aging time and temperature, plastic deformation, and composition on Q was studied.

764. Hiki, Y.,
INTERNAL FRICTION OF LEAD. II, Journal of Physical Society, Japan, Vol. 14, No. 5, May 1959, pp. 590-596.

The experimental results on the internal friction of lead single crystals are discussed on the basis of the dislocation theory. At low temperatures, the dependences of the internal friction on the strain amplitude and the frequency are well-explained with the pinned-down dislocation model.

765. Ibaraki, M. and Sugimoto, K.,
CHANGES OF INTERNAL FRICTION AND YOUNG'S MODULUS OWING TO GRAPHITIZATION IN MALLEABLE CAST IRON, Memoirs, Institute of Scientific and Industrial Research, Osaka University, Vol. 16, 1959, pp. 127-137.

Internal friction and its strain-amplitude dependence in malleable cast iron were measured at room temperature with a frequency of about 1 kc/sec. The order of the magnitude of internal friction and its strain-amplitude dependence is as-cast: < pearlite < ferrite < tempered martensite < martensite. The origin of the internal friction in this alloy may be considered to be due to the atomic rearrangement in graphite and also to be the atomic and (or) magnetic rearrangement in iron.

766. Ichiyama, T., Kawasaki, M., Kudo, I., and Waki, O.,
INTERNAL FRICTION IN QUENCH-HARDENED LOW CARBON STEEL AND COLD WORKED IRON, Japanese Institute of Metals, Journal, Vol. 23, December 1959, pp. 717-721.

A torsion pendulum is used to determine the effect of temperature. Distinct relaxation peaks are observed at 40° and 230° C. The relationship between internal friction and structure is determined.

767. Ichiyama, T., Kawasaki, M., Takashima, K., Saikawa, S., and Kusama, F.,
INTERNAL FRICTION MEASUREMENTS ON IRON AND STEELS, Japanese Institute of Metals, Journal, Vol. 23, July 1959, pp. 419-422.

Torsion pendulum is used to determine internal friction in electrolytic iron, Armco iron, and medium and high-carbon steels as influenced by heat treatment, temperature, and carbon content.

768. Ichiyama, T., Takashina, K., Imai, T., and Yoshimi, T.,
EFFECT OF HEAT TREATMENT ON THE SNOEK DAMP-
ING PEAK IN ARMCO IRON, Japanese Institute of Metals,
Journal, Vol. 23, September 1959, pp. 526-530.

Variations of the peak with quenching temperature are described. They indicate that carbon concentrates along the sub-boundaries and grain boundaries, and is probably responsible for alpha-veining and grain boundary ridging. In specimens freed from these phenomena in various ways, the broadening peak is the sum of the normal carbon and nitrogen peaks.

769. Imoto, S. and Mima, G.,
INTERNAL FRICTION ASSOCIATED WITH ANNEALING OF
COLD WORKED COPPER, Japanese Institute of Metals,
Journal, Vol. 23, July 1959, pp. 389-392.

Transverse bar method is employed to measure amplitude-dependent internal friction as a function of annealing temperature and time.

770. Ipatov, L. G.,
THE VIBRATIONS OF A FERROMAGNETIC MATERIAL IN
AN ALTERNATING MAGNETIC FIELD, Zhurnal Tekhnicheskoi
Fiziki, Vol. 29, No. 5, 1959, pp. 662-667.

The vibration of ferromagnetic materials in alternating magnetic fields is analyzed phenomenologically, and expressions are obtained for the dependence of the oscillation frequency, the damping constant and stiffness of the system of hysteresis, eddy current, field modulation amplitude and the steady magnetic field value. It is found experimentally that the vibration frequency depends on the magnetic state of the material.

771. Kaddou, K.,
CORRELATION BETWEEN INTERNAL FRICTION, ELEC-
TRICAL RESISTIVITY, AND TEMPER BRITTLENESS IN
STEEL, Dissertation Abstracts, Vol. 19, 1959, p. 1699
(University Microfilms, L. C. Card No. Mic 58-7501, 1958,
101 pp.).

The object of this investigation was to apply the internal friction test to the study of the role of carbon in temper

embrittlement. Distribution and concentration of solute carbon atoms were studied in both tough and embrittled conditions. Notched-bar impact, electrical resistivity and wire-wrap bend tests were also employed as supplementary tests to the internal friction, in studying this problem.

772. Kaelble, D. H.,
DYNAMIC MECHANICAL AND TENSILE PROPERTIES OF EPOXY RESINS, American Chemical Society, Division of Paint, Plastics, and Printing Ink Chemists, Proceedings, Vol. 19, No. 2, 1959, pp. 247-257.

Two versatile instruments and recent theory of the dynamic tensile properties of high polymers are combined to provide new insight into the mechanical properties of two typical cross-lined epoxy resins.

773. Kamel, R. and Attia, E. A.,
ON THE RELEASE OF COLD WORK IN CADMIUM IN TERMS OF MECHANICAL PROPERTIES, Philosophical Magazine, Vol. 4, May 1959, pp. 644-653.

Three principal recovery processes were investigated by isothermal internal friction and elasticity measurements on heavily cold-worked cadmium samples annealed at various temperatures up to 280° C.

774. Kamel, R.,
VACANCY PRECIPITATION IN QUENCHED GOLD FROM INTERNAL-FRICTION MEASUREMENTS, Acta Metallurgica, Vol. 7, No. 10, October 1959, pp. 680-681.

Internal-friction measurements were made at room temperature on gold strip, after quenching it from temperatures between 400° and 800° C. The results are discussed in terms of vacancies trapped by quenching, which annihilate at dislocation lines and form ring dislocations.

775. Kataev, G. I.,
APPARATUS FOR MEASURING WITH GREATER ACCURACY THE DEPENDENCE OF ELASTIC MODULI AND DAMPING DECREMENT ON TEMPERATURE, Industrial Laboratories, Vol. 24, No. 10, November 1959, pp. 1389-1392.

Not abstracted.

776. Kawaguchi, T.,
DYNAMIC MECHANICAL PROPERTIES OF NYLONS,
Journal of Applied Polymer Science, Vol. 2, 1959, pp. 56-61.

Dynamic mechanical properties, such as the measurements of elastic modulus and damping factor on polyamides and related polymers over a temperature range of -140° to 200° at 100 cps by means of a vibrating-reed method are described.

777. Keefer, D. and Wert, C.,
A STUDY OF REVERSION PHENOMENA IN THE CARBON-ALPHA-IRON SYSTEM, Transactions of the Metallurgical Society of American Institute of Mining, Metallurgical and Petroleum Engineers (AIME), Vol. 215, February 1959, pp. 114-119.

The results of this study indicate that sudden increases in aging temperature lead to reversion phenomena in carbon in the alpha-iron system. These phenomena are thought to be associated with the dissolution of carbide precipitates.

778. Kemnitz, G.,
INVESTIGATION OF COMPRESSION FATIGUE AND DAMPING PHENOMENA FOR TIRE CORDS, Kautschuk und Gummi, Vol. 12, 1959, pp. WT270-WT282.

Dynamic test measurements of growth in length, modulus of elasticity, damping, and hysteresis are reported for the Viskose cores; a vibration frequency of 50 cps was used.

779. Kampermann, T. and Clamroth, R.,
DETERMINATION OF RELATIVE DAMPING IN THE PRESENCE OF DIFFERENT PRESTRESSES, Kautschuk und Gummi, Vol. 12, 1959, pp. WT96-8, WT100, WT102, WT104, WT106.

Various definitions and concepts for relative damping are discussed. To determine the relations between relative damping, static stress, or prestress alternating stress, and phase angle, the work integral for a cyclic deformation was evaluated. Examination of the results indicated the advantage of defining the relative damping so that the prestress did not enter explicitly into the equation or definition (the

relative damping is the amount of energy which is transformed into heat divided by the amount of mechanical energy furnished by the vibration driver per cycle).

780. Kerwin, E. M., Jr.,
DAMPING OF FLEXURAL WAVES BY A CONSTRAINED
VISCOELASTIC LAYER, Acoustical Society of America,
Journal, Vol. 31, No. 7, July 1959, pp. 952-962.

For a number of years it has been known that flexural vibrations in a plate can be damped by the application of a layer of damping (viscoelastic) material that is in turn constrained by a backing layer or foil. A common example is the damping tape currently used in aircraft. This paper presents a quantitative analysis of the damping effectiveness of such a constrained layer.

781. King, J. C.,
ANELASTICITY OF NATURAL AND SYNTHETIC QUARTZ
AT LOW TEMPERATURES, Bell System Technical Journal,
Vol. 38, 1959, pp. 573-602.

A relaxation absorption that occurs at 50° K for a frequency of five megacycles was found to be several decades higher in synthetic than in natural quartz. X-irradiation eliminates the defect. X-irradiation, however, induces a relaxation absorption at 100° K and also darkens the crystal. The amplitude of the absorption is proportional to the color d.

782. Kotkin, G. L.,
ULTRASONIC WAVE ABSORPTION IN METALS, Zhurnal
Eksperimental'noi i Teoreticheskoi Fiziki, Vol. 36, March
1959, pp. 941-942.

A mathematical discussion of the attenuation due to electron-phonon interaction in metals.

783. Kou, C. C., Hu, C. L., Li, C. C., and Sun, C. C.,
REFINING OF COPPER, Chi Lin Ta Hsueh Tsu--Jan K'io
Hsueh Pao, No. 1, 1959, pp. 91-93.

Copper-wire was cold-worked and its internal friction decreased with increasing temperature of the subsequent annealing.

784. Krishtal, M. A.,
EVALUATION OF CONCENTRATION OF VACANCIES IN
GAMMA-IRON BY THE METHOD OF INTERNAL FRICTION,
Akademii Nauk, SSSR, Fizika Metallov i Metallovedenie,
Vol. 7, 1959, pp. 469-470.

Samples of Armco iron wire were heated at 1250° and 1370° in evacuated quartz tubes and quenched in water. Torsion tests showed that internal friction peaks decrease with increasing quenching temperature, the carbon concentration in the solid solution decreases, and the carbon concentration in the vacancies increases.

785. Krishtal, M. A. and Golovin, S. A.,
RELATIVE DAMPING OF TORSIONAL VIBRATIONS IN
THERMALLY TREATED STEELS 50A AND U7A, Nauchnye
Doklady Vysshei Shkoly, Met., No. 2, 1959, pp. 173-175.

Tempered steel U7A, containing carbon 0.7 percent, had a higher capacity for damping than steel 50A containing 0.49 percent carbon. The increase of toughness in specimens annealed at 200° was higher in specimens of U7A than of 50A.

786. Krishtal, M. A. and Golovin, S. A.,
THE NATURE OF INTERNAL FRICTION IN QUENCHED
AND ANNEALED STEEL, Akademii Nauk, SSSR, Fizika
Metallov i Metallovedenie, Vol. 2, 1959, pp. 294-301.

Quenched and annealed steels with 0.71 percent and 0.92 percent carbon were investigated. Maximum friction is noticed between 228° and 255°.

787. Krishtal, M. A. and Golovin, S. A.,
THE NATURE OF THE RELATIVE DAMPING OF OSCIL-
LATIONS IN QUENCHED AND LOW ANNEALED STEELS,
Akademii Nauk, SSSR, Fizika Metallov i Metallovedenie,
Vol. 2, 1959, pp. 302-308.

Investigations were carried out on 50A and U7A steels, respectively, 0.49 percent and 0.70 percent carbon after single and two-fold quenching, and after heat treatment at -196° and at higher temperature. These have shown that the relative damping is related to the presence of the residual austenite and its decay products during the anneal.

788. Kuroiwa, D. and Yamaji, K.,
INTERNAL FRICTION OF SINGLE CRYSTALS AND POLY-
CRYSTALLINE SAMPLES OF ICE, Teion Kagaku, No. 18A,
1959, pp. 97-114.

The loss factor tangent, δ , of the internal friction of polycrystalline ice has two maxima at -145° and at -35° to -120° ; the former maximum does not change its position on the temperature axis with the change of the frequency, f , of vibration.

789. Kurtze, G.,
BENDING WAVE PROPAGATION IN MULTILAYER PLATES,
Acoustical Society of America, Journal, Vol. 31, No. 9,
September 1959, pp. 1183-1202.

Flexural wave propagation and damping in multilayer plates is treated theoretically with use of impedance techniques. These techniques yield equivalent electrical circuits whose behavior is determined either by standard circuit analysis or by analog electrical measurements. The properties of two types of multilayer damping treatments are investigated in detail. The first type is a two-plate system enclosing a viscous liquid. The viscous liquid may also contain pressure-release partitions. The second type investigated consists of a layer of an air-filled porous material placed between a plate to be damped and an array of masses. Flexural wave measurements carried out on these multiple plates are shown to be in good agreement with calculation.

790. Lax, E.,
ACOUSTIC ATTENUATION IN ALUMINUM DUE TO
ELECTRON-LATTICE INTERACTION, Physical Review,
Vol. 115, 1959, pp. 1591-1594.

In pure polycrystalline aluminum at 3° to 70° , the 26 to 30 kilocycle attenuation was a quadratic function of frequency and linear in condition, but 50 percent greater than predicted by theory.

791. Lax, E. and Filson, D. H.,
SECOND LOW-TEMPERATURE PEAK IN THE INTERNAL
FRICTION OF ALUMINUM, Physical Review, Vol. 114,
No. 5, 1 June 1959, p. 1273.

A peak in the internal friction due to dislocations in aluminum was found well below the temperature of the usual Bordoni peak. Ultrasonic absorption measurements were made from 25 kc/sec to above 1 mc/sec, yielding a relaxation peak that varied with frequency over a temperature range of 21° to 31° K.

792. Lebedev, R. S. and Postnikov, V. S.,
DEPENDENCE OF INTERNAL FRICTION OF DEFORMED
IRON-BASE ALLOYS ON CONCENTRATION, Academii Nauk
SSSR, Fizika Metallov i Metallovedenie, Vol. 7, 1959, pp.
410-417.

By using the method of torsional vibration, the authors investigated the effect of concentration on the initial friction of iron, silicon, and iron-titanium alloys previously deformed 91 percent by compression. Two sets of iron-base alloys were studied: with 0.06 percent to 3 percent silicon, and with 0.3 percent to 2.2 percent titanium.

793. Lebedev, R. S. and Postnikov, V. S.,
THE INFLUENCE OF PLASTIC DEFORMATION UPON THE
INTERNAL FRICTION OF IRON AND IRON-NICKEL ALLOYS,
Academii Nauk SSSR, Fizika Metallov i Metallovedenie, Vol.
8, 1959, pp. 310-314.

The electrolytic iron on compression to 8, 17, 30, 47, and 92 percent and iron-nickel alloy (four percent nickel) on compression from 20 to 80 percent show that the dependence of the internal friction of iron and iron-nickel alloy upon the degree of preliminary deformation, rate of heating, and the time of the isothermal lag are comparable to an iron-tungsten alloy. The internal friction of the iron-nickel alloy has two maxima, while that of the iron-tungsten alloy has only one, which disappears after annealing at high temperatures.

794. Lewis, B.,
ENERGY LOSS PROCESSES IN FERROELECTRIC CERAM-
ICS, Proceedings, Physical Society, London, Vol. 73, 1959,
pp. 17-24.

By a study of aging effects in which permittivity, elastic compliance and the electrical and mechanical loss coefficients decrease with time, the principal ferroelectric loss process in low fields is identified as micro-hysteresis associated with small-amplitude domain boundary movement. Larger fields produce macrohysteretic effects due to large-scale boundary movement, and the permittivity, compliance and loss coefficients are increased. Although boundary movement is responsible for almost all the energy loss, its contribution to permittivity and compliance is usually small compared with induced effects within each domain. Thus a change in magnitude of boundary movement alters the permittivity and compliance only slightly but changes the loss coefficients considerably.

795. Lieberman, L.,
ACOUSTIC ABSORPTION ARISING FROM MOLECULAR
RESONANCE IN SOLIDS, Physical Review, Vol. 113, 1959,
pp. 1052-1055.

Resonance phenomena causing anomalously high acoustic absorption can occur when lattice and internal molecular vibration frequencies overlap. A method given for calculation of resonance absorption is illustrated for benzene.

796. Livshits, B. G. and Makhukov, N. G.,
TEMPERING OF COLD-DEFORMED K4ONCr (K4OHXM)
ALLOY, Akademii Nauk, SSSR, Fizika Metallov i Metal-
lovedenie, Vol. 8, 1959, pp. 400-405.

The investigation of the spring-type alloy K4ONCr (the basis of which is the cobalt-chromium-nickel-iron system) by measuring hardness, electrical resistance, heat expansion, elasticity constant, and internal friction, showed that aging of this alloy (after forging) involves two independent processes. One takes place preferentially in the temperature interval 300° to 50° and probably leads to the formation of the atomic segregation of the Guinier-Preston-type zone (K-state). The second process takes place in the temperature interval 550° to 700° and leads to separation.

797. Lord Manufacturing,
ENGINEERING REPORT ON DAMPED STRUCTURAL SECTIONS AND LAMINATED PANELS by B. W. Campbell,
October 1959, Report No. 325.

A theoretical analysis is given and experimental results are presented to show the effectiveness of adding damped elements on an undamped cantilever beam. The resulting amplitude of resonant vibrations was one-half that of the beam alone.

798. Lozinskii, M. G. and Fedorovskii, A. E.,
EFFECT OF VANADIUM, TUNGSTEN, CHROMIUM, AND MOLYBDENUM ON THE INTERNAL FRICTION AND THE RATE OF AGING OF TECHNICAL IRON, Akademiya Nauk SSSR, Otdeleniye Tekhnicheskikh Nauk, Izvestiya, Metallurgiya i Toplivo, No. 1, 1959, pp. 64-70.

The changes of internal friction with the temperature were experimentally determined for the iron alloys with vanadium, tungsten, chromium, and molybdenum. The behavior of alloys appears to indicate that the effects of alloying elements, with the exception of vanadium, are qualitatively the same.

799. Lozinskii, M. G. and Sinodova, E. P.,
TEMPERATURE DEPENDENCE OF THE HARDNESS OF IRON-MOLYBDENUM AND NICKEL-MOLYBDENUM ALLOYS, Metalloved. i Termichesk. Obrabotka Metal., No. 5, 1959, pp. 35-40.

Two experimental iron-molybdenum alloys containing 4 percent and 12 percent molybdenum, and two nickel-molybdenum alloys containing 7 percent and 25 percent molybdenum were given various heat-treatments. The progress of age-hardening was followed by hot-hardness measurements in vacuum.

800. Lysaght Central Research Laboratory,
INTERNAL FRICTION EFFECTS IN IRON AND IRON-SILICON ALLOYS by P. M. Robinson, 22 October 1959,
Research Report No. 160.

When nitrogen is introduced into solid solution in iron alloys, anelastic effects are superimposed on the mechanical

damping due to dislocations. The presence of nitrogen in solution in iron-silicon alloys results in the occurrence, under certain conditions, of five peaks in the internal friction/temperature curve. The internal friction effects have been used to determine the solubility of nitrogen in equilibrium with the precipitated nitride in iron-silicon alloys.

801. Mackinnon, L. and Myers, A.,
ULTRASONIC ATTENUATION IN SUPERCONDUCTING AND
NORMAL Hg, Proceedings, Physical Society, London, Vol.
73, 1959, pp. 291-296.

The relative attenuations of 10 mc/sec longitudinal ultrasonic waves were studied in superconducting and normal mercury over the temperature range of 1.17° to 4.2° K. As in tin, lead, and indium, there is a marked difference in the attenuation for the two different stages consistent with the energy-gap theory.

802. Maksimyuk, P. A.,
STUDY OF THE AGING PROCESS FOR Al-Cu ALLOYS BY
THE INTERNAL FRICTION METHOD, Nauck. Zap. Kiivs'k
Derzh. Univ., Vol. 18, No. 3, 1959, pp. 159-166.

The study confirmed that the phases of naturally and artificially aged aluminum-4 percent copper alloy are not identical. The hardening temperature and the holding time at temperature affect the subsequent aging of the alloy.

803. Martin, D. E. and Brinn, J.,
SOME OBSERVATIONS ON THE PLASTIC WORK REQUIRED
TO FRACTURE STAINLESS STEEL UNDER CYCLIC LOAD-
ING, Proceedings, American Society for Testing Materials,
Vol. 59, 1959, pp. 677-690.

The purpose of the study was to examine the total plastic work up to fracture as a possible index for approximate prediction of fatigue life. Observed results make clear that such a relationship is unreliable. Tests were performed on AISI Type 347 stainless steel specimens subjected to low-cycle fully-reversed axial stress at elevated temperature.

804. McCrum, N. G.,
INTERNAL FRICTION STUDY OF POLYTETRAFLUORO-
ETHYLENE, Journal of Polymer Science, 1959, p. 5
(International High-Polymer Conference, Nottingham, 21-24
July 1958, Paper N 37).

A torsion pendulum has been utilized to investigate internal friction of polytetrafluoroethylene, and transition points are indicated at 176°, 300°, and 400° K.

805. McCrum, N. G.,
STUDY OF INTERNAL FRICTION IN COPOLYMERS OF
TETRAFLUOROETHYLENE AND HEXAFLUOROPROPYLENE,
Makromolekulare Chemie, Vol. 34, No. 1, 1959, pp. 50-66.

The temperature variation of the internal friction of tetrafluoroethylene-hexafluoropropylene (TFE-HFP) copolymers was studied using a torsion pendulum at frequencies cycle 1 cps. The composition varied from 0 to 14 mole percent HFP. Increasing HFP content was found to (1) depress the temperature of the crystal disordering transition, (2) increase the size and depress the temperature of the glass I internal friction peak from 400° to 348° K, and (3) decrease the size of the glass II peak.

806. Mentel, T. J.,
VIBRATIONAL ENERGY DISSIPATION AT STRUCTURAL
SUPPORT JUNCTIONS, Structural Damping, American
Society of Mechanical Engineers Publication, December 1959,
pp. 89-116 (J. E. Rizicka, Editor).

A simplified theory is presented which shows that if structural design parameters are suitable optimized, the energy dissipation at the supports of a panel may, in certain cases, be made to exceed the inherent material damping by several orders of magnitude. The results of preliminary experimental tests are also discussed.

807. Merkulov, L. G. and Yakovlev, L. A.,
ABSORPTION OF ULTRASONIC WAVES IN CRYSTAL
QUARTZ AT FREQUENCIES UP TO 1000 mc/sec,
Akusticheski Zhurnal, Vol. 5, No. 3, 1959, pp. 374-376.

Measurements were made with shear and longitudinal waves propagated along the x-, y- and z-axes in the temperature interval -200° to 200° C.

808. Michigan University, Willow Run Laboratories,
REDUCTION OF THE RESPONSE TO VIBRATION OF STRUC-
TURES POSSESSING FINITE MECHANICAL IMPEDANCE.
PART I, November 1959, Report No. TR 2892-4-T.

This article reviews dynamic mechanical properties of rubber-like materials.

809. Mima, G.,
DIFFERENCE BETWEEN EFFECTS OF SINGLE-
ISOTHERMAL AND SUCCESSIVE-ISOTHERMAL ANNEAL-
INGS IN COLD-WORKED ALUMINUM, Technol. Repts. Osaka
Univ., Vol. 10, 1959, pp. 489-503.

Specimens of com. aluminum with impurities iron 0.36 percent, silicon 0.16 percent and copper 0.003 percent and of 99.5 percent and 99.98 percent aluminum were subjected to both single-isothermal and successive-isothermal annealing. The effects of these heat-treatments on the recovery and recrystallizing of aluminum were investigated by measurements of the room temperature internal friction, the tensile strength, and elongation.

810. Mima, G.,
EFFECT OF SUCCESSIVE ANNEALING UPON THE ROOM
TEMPERATURE INTERNAL FRICTION OF COLD-
COMPRESSED COMMERCIALY PURE POLYCRYSTALLINE
ALUMINUM, Technol. Repts. Osaka Univ., Vol. 8, 1959,
pp. 373-383.

The internal friction versus the amount of cold compression for specimens annealed at room temperature for 50 minutes after cold compression has sharp peaks at about 15 percent and 55 percent reduction in area. The first peak decayed completely after annealing at room temperature for 5000 minutes, but the second peak did not decay at room temperature for 31 days. It is believed that the decrease of internal friction is attributable to the stress-induced diffusion of the solute atoms on the dislocations.

811. Mima, G., Hayashi, M., and Yamano, I.,
DIFFERENCES BETWEEN SINGLE ISOTHERMAL ANNEAL-
ING EFFECTS AND SUCCESSIVE ISOTHERMAL ANNEALING
EFFECTS IN COLD WORKED ALUMINUM, Light Metals,
Vol. 9, September 1959, pp. 29-35.

Changes in internal friction and the tensile properties in the recovery process are related to the difference between successive and single isothermal annealing.

812. Mima, G. and Mizuta, M.,
THE RELATION BETWEEN HEAT-TREATMENTS AND THE
ROOM-TEMPERATURE INTERNAL FRICTION OF SOME
CARBON STEELS, Nippon Kinzoku, Vol. 23, August 1959,
pp. 469-473.

The internal friction of martensite specimens is proportional to carbon content, and is caused by stress induced diffusion of carbon. In annealed specimens containing coarse free ferrite, the amplitude-dependent internal friction is caused by magnetomechanical hysteresis.

813. Mirkin, I. L.,
THE HARDENING AND SOFTENING OF FERRITE ALLOYED
WITH VANADIUM, Metalloved. i Termichesk. Obrabotka
Metal, Vol. 9, 1959, pp. 39-41.

The physical properties of ferrite containing 2.13 percent vanadium (I) was compared with vanadium-free ferrite (II). I is softer and slightly more susceptible to plastic deformation than II below 400°. I is markedly superior to II in the range 400° to 600°. On heating, the internal friction of I increases more slowly than that of II, when measured by vibration damping techniques.

814. Mirkin, I. L.,
HARDENING AND SOFTENING OF FERRITE ALLOYED
WITH MANGANESE, Izvest. Vysshikh Ucheb. Zavedenii,
Chernaya Met., Vol. 2, No. 6, 1959, pp. 63-66.

The mechanical properties, such as tensile strength, hardness, internal friction, coercive force, and shear modulus were determined.

815. Morse, R. W. and Gavenda, J. D.,
MAGNETIC OSCILLATIONS OF ULTRASONIC ATTENUATION IN A COPPER CRYSTAL AT LOW TEMPERATURES, Phys. Rev. Letters, Vol. 2, No. 6, 15 March 1959, pp. 250-252.

Measurements were made between 15 and 75 mc/sec, in fields H up to 6.5 kilograms, at 4° K. For longitudinal waves propagated along (001), with H // (100), about seven maxima in attenuation are found, accurately periodic in 1/H, and corresponding to an electron momentum of 1.16×10^{19} g cm sec⁻¹. With H// (110), a different and more complex pattern is found, in qualitative agreement with the model proposed for copper by Pippard. The high field attenuation also shows strong anisotropy.

816. Morse, R. W., Olsen, T., and Gavenda, J. D.,
EVIDENCE FOR THE ANISOTROPY OF THE SUPERCONDUCTING ENERGY GAP FROM ULTRASONIC ATTENUATION, Phys. Rev. Letters, Vol. 3, 1959, pp. 15-16.

Longitudinal attenuation of waves to 80 mc/sec in oriented tin crystals at 1° K shows energy-gap anisotropy.

817. Muus, L. T., McCrum, N. G., and McGrew, F. C.,
THE RELATION OF PHYSICAL PROPERTIES TO STRUCTURE IN LINEAR POLYMERS OF ETHYLENE AND PROPYLENE, Society of Plastics Engineers (SPE) Tech. Papers, Vol. 5, Paper No. 1, 1959, 5 pp.

The relation between torsion modulus and internal friction as a function of temperature was plotted for higher-d. polyethylene and isotactic propylene.

818. Nagamatsu, K.,
ON THE MECHANICAL RELAXATION TIME SPECTRA OF CRYSTALLINE POLYMERS, Supplement, Progress of Theoretical Physics (Japan), No. 10, 1959, pp. 73-81 (Relaxation Phenomena of Polymers Meeting, Kyoto, 1958).

The time-temperature superposition principle of viscoelasticity was found to be applicable also to crystalline polymers. As an example, the calculated relation of mechanical loss tangent versus temperature for polytrifluorochloroethylene is shown to be in good agreement with that

obtained by the observation of damping free oscillation. Comparison of these results on the temperature dependency of mechanical loss tangent has revealed the relation between the viscoelasticity of crystalline polymers and the glass transition temperature.

819. National Aeronautics and Space Administration, PLASTIC DEFORMATION IN BINARY ALUMINUM ALLOYS BY INTERNAL-FRICTION METHODS by E. C. Olson, R. E. Maringer, L. L. Marsh, and G. K. Manning, 1959, Memo, Vol. 3-3-59W, 31 pp.

The damping capacity of several aluminum-copper alloys has been investigated during tensile elongation. The damping characteristic depends on strain rate, strain, temperature, composition, and heat-treatment. A tentative hypothesis based on the acceleration of solute atom diffusion by deformation-produced vacancies, is proposed to account for the observed behavior. Internal-friction maximum are observed in deformed aluminum and aluminum-copper alloys at -70° and -50° .

820. Natta, G., Baccaredda, M., and Butta, E., ELASTIC AND ANELASTIC BEHAVIOR OF SOME ISOTACTIC POLYMERS, Chim. e Ind. (Milan), Vol. 41, 1959, pp. 737-740.

The mechanical dynamic properties of linear polymers of alpha-olefins (polypropylene, polybutylene, and polystyrene), containing crystalline fractions of various steric purity, were determined. Relatively high values of the internal dissipation in sufficiently wide temperature ranges are observed only in products having a high proportion of noncrystalline fractions.

821. Naumkina, N. I., Tartakovskii, B. D., and Efrussi, M. M., EXPERIMENTAL INVESTIGATION OF SOME VIBRATION ABSORBING MATERIALS, Akusticheski Zhurnal, Vol. 5, No. 2, 1959, pp. 196-201.

An experimental layout is given for measuring the dynamic elastic properties of materials employed for cutting down the vibrations propagated along the metal parts of machinery and other constructions.

822. Niblett, D. H. and Wilks, J.,
THE INTERNAL FRICTION OF ANNEALED COPPER AT
LOW TEMPERATURES, Proc. Phys. Soc., Vol. 73, Part 1,
January 1959, pp. 95-99.

The internal friction of annealed polycrystalline copper was measured as a function of strain amplitude in the temperature range 20° to 300° K. Both the amplitude-dependent and the amplitude-independent contributions to the decrement increase with increasing temperature over the whole range. Current theories are inadequate to account for the observed dependence of the friction on both strain amplitude and temperature.

823. Nishihara, M., Hakano, T., and Makioka, M.,
EFFECT OF NORMALIZED STRUCTURE IN MEDIUM-
CARBON STEEL ON MECHANICAL PROPERTIES AND
ULTRASONIC TRANSMISSION, Iron and Steel Institute of
Japan, Vol. 45, 1959, pp. 799-803.

The relation between the microstructure and the mechanical properties (ductility and toughness) was studied statistically to clarify the effect of acicular pearlitic structure recognized in normalized medium-carbon steel on its mechanical properties. At the same time, the ultrasonic transmission was investigated on various microstructures made by the laboratory treatment, by which the relation between the microstructure and the apparent ultrasonic attenuation coefficient was determined.

824. Northwestern University, Evanston, Illinois,
AN INVESTIGATION OF PHASE TRANSFORMATIONS AND
OTHER STRUCTURAL CHANGES IN METALS BY MEASURE-
MENT OF ELASTICITY AND INTERNAL FRICTION by M. E.
Fine and A. Kelly, 30 September 1959, AFOSR TR 59-141.

Not abstracted.

825. Oding, I. A., Glozinskii, M. G., and Gordienko, L. K.,
EFFECT OF HIGH-TEMPERATURE CREEP ON INTERNAL
FRICTION AND MODULUS OF ELASTICITY, Metallovedenie
i Termicheskaya Obrabotka Metallov, December 1959, pp.
24-31.

Technical iron and a nickel-chromium alloy were heat-treated and exposed to a tensile load at 750° and 400° C

through various times. Internal friction and modulus of elasticity were then determined between 20° to 600° C.

826. Papadakis, E. P.,
ULTRASONIC ATTENUATION IN SAE 3140 AND 4150 STEEL,
PB 142424, April 1959, p. 93 (U. S. Govt. Res. Rep., Vol.
32, October 1959).

Attenuation of longitudinal ultrasonic waves is studied by pulse technique in blocks of SAE 3140 and 4150 steel to determine loss mechanism and find methods for precision testing microstructure of materials. Scattering by the grains in polycrystalline steel is responsible for attenuation in tempered steel.

827. Pare, V. K.,
LOW-TEMPERATURE INTERNAL FRICTION IN COPPER,
Dissertation Abstracts, Vol. 19, 1959, p. 2985, Thesis
(University Microfilms, L. C. Card No. Mic 59-1196, 182 pp.).

Measurements were made of internal friction in cold-worked copper single crystals as a function of temperature from 4° to 300° K. Particular attention was given to the Bordoni peak, a prominent maximum at about 80° K in the curve of internal friction versus temperature, apparently representing a thermally activated relaxation process. Since the height of the peak is sensitive to both cold-working and impurity content, while the temperature T_{max} at which it occurs is nearly constant, it is assumed that the relaxation process involves dislocations bound by an intrinsic lattice barrier, the periodic potential of which gives rise to the Peierls force.

828. Pavlov, V. A., Gaidukov, M. G., Datsko, O. I., Noskova, N. I., and Pereturina, I. A.,
EFFECT OF STRUCTURAL CHARACTERISTICS ON THE
BEHAVIOR OF METALS AT HIGH TEMPERATURE,
Issledovaniya po Zharoproch. Splavam, Akad. Nauk SSSR,
Inst. Met. ins. A. A. Baikova, Vol. 4, 1959, pp. 26-35.

The modulus of elasticity decreases continually with the increase of copper concentration in solid solution in nickel (from 21,600 for nickel to 17,600 kc/sq mm for nickel with 40 percent copper). Curves of internal friction versus

temperature have two maxima for pure nickel. One between 400° and 500° (after three hours of annealing) is related to relaxation stresses along the grain boundaries. Another maximum between 650° and 750° (after three hours of annealing) depends very much on heat and mechanical treatment. Plastic deformation increases it, and shifts it toward lower temperatures, while increase in annealing temperature decreases its value and shifts it toward higher temperatures.

829. Petrova, V. Z. and Avgustinik, A. I.,
RELATION BETWEEN THE STRESSED STATE OF PORCE-
LAIN AND THE DAMPING OF VIBRATIONS EXCITED IN IT,
Zhurnal Prikladnoi Khimii, Vol. 32, No. 7, 1959, pp. 1445-
1451.

An apparatus for measuring the log decrement (δ) of vibration damping in porcelain samples is described. The value of δ increased with increasing moisture content in the sample. A connection between the appearance of the double peaks and the presence of stresses in the samples is assumed.

830. Pines, B. Y. and Den, S. G.,
INVESTIGATION OF INTERNAL FRICTION IN SINTERED
MATERIALS, Akademii Nauk, SSSR, Fizika Metallov i
Metallovedenie, Vol. 8, 1959, pp. 599-606.

The temperature dependence of the logarithmic damping decrement for the torsional vibration Q^{-1} was investigated in metalloceramic specimens prepared from powders of copper, nickel, and iron, and mixtures of copper-nickel and copper-iron. It was established that the energy of activation (height and width of the internal friction peaks) for pure metals and powder mixtures of copper-nickel depends upon duration of preliminary calcining. In mixtures of powders of copper-nickel and copper-iron the energy of activation determined from modulation shows linear dependence on the volume concentrations of mixtures.

831. Pines, B. Y. and Den, S. G.,
A STUDY OF THE INTERNAL FRICTION IN POWDER
METALLURGICAL BODIES. IV. SPECIMENS FROM
BINARY POWDERS OF NONINTERACTING COMPONENTS
Cu-Mo, Cu-W, Physics of Metals and Metallography, Vol. 8,
No. 6, 1959, pp. 56-60.

The temperature dependence of internal friction was determined by using a torsion pendulum for powder

metallurgical specimens of binary mixtures of the powders copper-molybdenum and copper-tungsten. Two maxima were obtained for each specimen, one of which corresponds to the processes on the copper grain contacts, and the other to the processes on the contacts of grains of different kinds. The energies of activation were determined from the frequency shift of the maximum and from the background of the curve $Q^{-1} = Q^{-1}(T)$.

832. Plenard, E.,
MODULUS OF ELASTICITY AND DAMPING CAPACITY OF
GREY CAST IRON, Gjuteriet, Vol. 49, No. 8, 1959, pp.
207-209.

Methods of determining the modulus are outlined, and the effect of graphite structure on the modulus and damping capacity are discussed.

833. Polotskii, I. G. and Benieva, T. Ya.,
EFFECT OF HEAT-TREATMENT ON ELASTIC PROPERTIES
AND INTERNAL FRICTION OF NICKEL-BASE ALLOYS,
Issledovaniya po Zharoproch. Splavam, Akad. Nauk SSSR,
Inst. Met. im. A. A. Baikova, Vol. 4, 1959, pp. 202-207.

Phenomena were studied which occur in nickel alloys during low-temperature annealing. Also the effect of aluminum and titanium additions on the kinetics of formation of the K state in nickel-chromium alloys was investigated, by determining the Young modulus and internal friction, after a preliminary heat-treatment. When measuring the internal friction at a frequency of 800 cps no changes were observed during the formation of the K state in nickel-chromium, nickel-molybdenum, and nickel-chromium-titanium-aluminum. On the other hand, alloy EI-437 shows during aging increase in internal friction with increased formation of alpha phase.

834. Polots'kii, I. G., Khodov, Z. L., and Levin, G. I.,
EFFECT OF OXYGEN IMPURITY AND ALLOYING ADDI-
TIONS ON THE ELASTIC PROPERTIES AND INTERNAL
FRICTION OF CHROMIUM, Ukrain. Fiz. Zhur., Vol. 4,
No. 1, 1959, pp. 116-121.

A 99.9 percent pure chromium was used. Addition of 0.11 atomic percent zirconium or oxygen produced a minimum of elasticity modulus that lies in the room temperature

interval and an anomalous change in damping decrement. Addition of 2.9 atomic percent iron to chromium decreases the modulus; this indicates a weakening of interatomic bonds. The reversed effect is observed in chromium-beryllium alloy.

835. Polotsky, I. G. and Khodov, Z. L.,
THE TEMPERATURE-DEPENDENCE OF THE SHEAR
MODULUS AND INTERNAL FRICTION OF SOME NICKEL-
BASE ALLOYS, Akademii Nauk, SSSR, Fizika Metallov i
Metallovedenie, Vol. 7, No. 2, 1959, pp. 274-277.

Using a Kê pendulum the variation of damping with temperature was measured for some nickel-molybdenum alloys containing three-to-nine atomic percent molybdenum and for Nichromes containing approximately two atomic percent aluminum or titanium.

836. Postnikov, V. S.,
INTERNAL FRICTION IN PURE METALS AND ALLOYS AT
HIGH TEMPERATURES, Issledovaniya Zharoproch. Splavam,
Akad. Nauk SSSR, Inst. Met. im. A. A. Baikova, Vol. 4,
1959, pp. 181-187.

A theoretical discussion is given of the mechanism of elastic energy dissipation owing to migration of atomic defects in the crystalline lattice. This mechanism predominates at high temperatures, and this explains why internal friction increases sharply at higher temperatures and then drops sharply again.

837. Postnikov, V. S.,
DISSIPATION OF ENERGY IN A SPECIMEN OSCILLATING
AT HIGH TEMPERATURES, Physics of Metals and
Metallography, Vol. 7, No. 5, 1959, pp. 126-129.

Damping of low-frequency one-cycle-per-second oscillations with small amplitude is explained on a vacancy-migration theory. Results of Postnikov's theory are in agreement with published measurements on pure aluminum and are compared with dislocation mechanisms.

838. Postnikov, V. S. and Lebedev, R. S. ,
EFFECT OF INTERNAL DEFORMATION ON THE INTERNAL
FRICTION OF THE IRON-TUNGSTEN ALLOY, Akademi
Nauk, SSSR, Fizika Metallov i Metallovedenie, No. 1, 1959,
pp. 95-102.

The experimental results confirm the conclusion that internal friction at high temperature may serve as a special indication of the strength of the alloy.

839. Potter, R. F. and Wasilik, J. H. ,
MECHANICAL AND ELECTROMECHANICAL PROPERTIES
OF INDIUM ANTIMONIDE, Spring Mtg. Electrochem. Soc. ,
1959.

An investigation of the mechanical and electromechanical properties of indium antimonide, including its elastic content, anelastic effects, and piezo resistivity, was presented.

840. Powers, R. W. and Doyle, M. V. ,
THE ASSOCIATION OF OXYGEN ATOMS IN INTERSTITIAL
SOLID-SOLUTION IN TANTALUM, Transactions, American
Institute of Mining, Metallurgical and Petroleum Engineers,
Vol. 215, No. 4, 1959, pp. 655-665.

Internal-friction measurements show that the mechanical relaxation found in interstitial solid-solution alloys of tantalum containing up to 0.01 atomic fraction oxygen is the sum of two separate relaxation processes, that is, a stress-induced ordering of oxygen atoms each of which is associated with a neighboring oxygen atom.

841. Powers, R. W. and Doyle, M. V. ,
DIFFUSION OF INTERSTITIAL SOLUTES IN THE GROUP
V TRANSITION METALS, Journal of Applied Physics, Vol.
30, No. 3, April 1959.

Diffusion data obtained by a variety of relaxation techniques are presented for oxygen, nitrogen, and carbon in vanadium, niobium, and tantalum. These data are in agreement with those obtained by the more conventional concentration gradient techniques in the few instances where such information is available. The pattern of activation energies suggest that lattice strain considerations alone are insufficient to explain the activation process involved in interstitial diffusion.

842. Rawlings, R. and Robinson, P. M.,
AN INTERNAL-FRICTION PEAK DUE TO SLOW-MOVING
DISLOCATIONS IN IRON-NITROGEN ALLOYS, Acta
Metallurgica, Vol. 7, No. 10, October 1959, pp. 659-663.

A small peak in the internal friction-temperature curve has been observed a few degrees above the Snoek peak (due to stress-induced ordering) in iron-nitrogen alloys. The peak is produced when specimens are quenched from above the alpha-gamma transformation temperature, or when specimens quenched from below the transformation temperature are lightly strained. It is absent in the specimens quenched from below the transformation temperature and not strained. Evidence is given for the belief that this new peak is due to slow-moving dislocations.

843. Redwood, M.,
ABSORPTION OF ULTRASONIC WAVES IN SOLIDS,
Mémoires Scientifiques de la Revue de Métallurgie, Vol. 56,
July 1959, pp. 172-180.

This article investigates possible causes of error in determination of absorption in low damping capacity solids at frequencies between 10 and 300 mc/sec, and the role of dislocations in experimentally observed variation of internal friction in metals as influenced by such factors as frequency and temperature.

844. Reiner, M.,
THE FLOW OF MATTER, Scientific American, Vol. 201,
No. 6, December 1959, p. 122.

Not abstracted.

845. Reneker, D. H.,
ULTRASONIC ATTENUATION IN BISMUTH AT LOW
TEMPERATURES, Physical Review, Vol. 115, 1959, pp.
303-313.

Various orientations were measured at 12 to 84 mc/sec. The magnetic-field dependence of low-temperature attenuation in bismuth shows three oscillatory components and a saturation region at 5 to 1600 oersteds. Data on the temperature-frequency dependence of the zero-field attenuation are given.

846. Reznikovskii, M. M., Priss, L. S., and Khromov, M. K.,
ON THE LINKAGE BETWEEN RESISTANCE TO FATIGUE
STRENGTH, HYSTERESIS AND CHEMICAL STABILITY OF
RUBBERS, Kolloid-Zeitschrift, Vol. 21, No. 4, 1959, pp.
458-463.

An investigation was made of the dynamic fatigue strength of rubbers and its linkage with the modulus of internal friction. Investigations were made of rubber variants of the type "Bracker" on the basis of synthetic rubber SKS-30A with the highest possible value for the limit of strength and the dynamic modulus and with progressively decreasing magnitudes for the modulus of internal friction. It is shown that with increases in "life" and the temperature, when the role of the mechanical factors diminishes, the rubbers under investigation gradually lose their remanence in comparison with the SKB rubbers which are chemically of greater stability.

847. Robinson, P. M. and Rawlings, R.,
THE INFLUENCE OF SOLUTE ATOMS ON THE DAMPING
DUE TO DISLOCATIONS IN IRON ALLOYS, Philosophical
Magazine, [8], Vol. 4, 1959, pp. 938-947.

The effect of silicon and oxygen in solid solution on the damping of iron was studied. The damping is independent of vibrational amplitude up to a critical amplitude. The variation of this critical amplitude with temperatures and solute concentration was studied.

848. Romiti, A.,
EFFECTS OF ELASTIC HYSTERESIS UPON THE VIBRA-
TIONS OF A ROTATING SHAFT, Atti Accad. Naz. Lincei,
R. C. Cl. Fis., Mat. Nat., Vol. 26, No. 3, March 1959,
pp. 372-378.

Author proceeds from the idea that the stability of a rotating shaft is due to the effects of elastic hysteresis. The angular velocity of rotation of the shaft and the angular velocity of the deformed fiber are introduced in the study. The difference between these two quantities is due to the effects of hysteresis, quantitatively determined by the properties of the material. The paper shows, with the aid of mathematical conditions, the cases in which the motion is stable or unstable for shaft velocities lower or higher than the critical velocity.

849. Rusina, J. ,
INFLUENCE OF MOLYBDENUM AND VANADIUM AS
CARBIDE-FORMING ALLOYING ELEMENTS IN THE PRE-
CIPITATION AND DIFFUSION OF CARBON IN FERRITE,
Hutnické Listy, Vol. 14, July 1959, pp. 608-610.

This article records the determination of damping properties of two low-alloy steels after annealing at varying temperatures following quench hardening. The damping properties do not always permit conclusions to be drawn as to the precipitation and diffusion of carbon.

850. Ruzicka, J. E. ,
INCREASED RELIABILITY OF AVIATION AND MISSILE
ELECTRONICS BY USE OF DAMPED STRUCTURES, Society
of Automotive Engineers Preprint, 1959.

This paper deals with the control of elastic body resonances by use of damped structures. Several idealized models of the problem are analyzed, constructed, and tested to indicate the beneficial properties of highly damped structures excited by a wide range of frequencies. The effect of high structural damping on the isolation of vibration is also studied.

851. Ruzicka, J. E. , Editor,
STRUCTURAL DAMPING, American Society of Mechanical
Engineers, Separate Publication, December 1959.

This publication includes six papers presented at a colloquium on structural damping held at the American Society of Mechanical Engineers annual meeting in Atlantic City, New Jersey, in December 1959. A selected bibliography of the structural damping field is included. The colloquium was sponsored by the Shock and Vibration Committee of the Applied Mechanics Division of the society.

852. Sacerdote, C. B. ,
MEASUREMENTS ON DAMPING MATERIALS SPRAYED ON
STEEL TUBES, Acustica, Vol. 9, No. 2, 1959, pp. 75-78.

Theoretical expressions are derived for the resonant frequency of a tube vibrating longitudinally when its outer surface is completely or partially coated with a damping material. Experiments are described using a steel tube

90 centimeters long, 2.4 centimeters in diameter, and 0.1 centimeter wall thickness having a natural frequency of about 2800 cps when uncoated; curves are given of the resonant frequency, decrement, and loss factor for the tube coated with various thicknesses of bituminous or plastic material.

853. Sazhin, B. L., Skurikhina, V. S., and Il'in, Yu. A., INVESTIGATION OF THE DIELECTRIC LOSSES AND ULTRASONIC WAVE ABSORPTION IN POLYPROPYLENE, Vysokomol. Soed., Vol. 1, No. 9, 1959, pp. 1383-1389.

Results are presented of measurements of the slope of dielectric losses at temperatures ranging from -100° to 150° C and frequencies 400 to 10^{10} cps and of the attenuation coefficient of longitudinal ultrasonic waves in propylenes of varying densities.

854. Scheil, E., Wachtel, E., and Gurbaxani, G., THE MECHANICAL DAMPING OF STEELS AFTER HARDENING AND TEMPERING, Archiv für das Eisenhüttenwesen, Vol. 30, August 1959, pp. 497-501.

Damping characteristics of two dead mild steels, two carbon steels containing 0.48 and 0.95 percent carbon, and an iron-nickel alloy with 9.44 percent nickel were investigated. The damping maximum observed in high carbon steels at 200° C on this maximum are discussed, and the influence of residual deformation and martensite formation in causing the maximum are examined.

855. Schnitzel, R. H., HIGH-TEMPERATURE DAMPING OF TANTALUM, RHENIUM, AND TUNGSTEN, Journal of Applied Physics, Vol. 30, 1959, pp. 2011-2012.

An apparatus is described for internal friction measurements at temperatures up to at least 2000° . Data are presented for tungsten, rhenium, and tantalum.

856. Schnitzel, R. H.,
HIGH-TEMPERATURE INTERNAL FRICTION OF TUNGSTEN,
Reactive Metals (Metallurgical Society Conferences), Vol. 2,
Interscience Publishers, Incorporated, New York, 1959,
pp. 245-263.

Determination is made of grain-boundary peak and effect of doping additives through measurement of internal friction versus high temperature in polycrystalline and large-grained "single-crystal" tungsten.

857. Schoeck, G. and Seeger, A.,
THE FLOW STRESS OF IRON AND ITS DEPENDENCE ON
IMPURITIES, Acta Metallurgica, Vol. 7, July 1959, pp.
469-477.

This article investigates redistribution of solute interstitial onto lower energy lattice sites which takes place in the stress field of a dislocation, the locking of dislocations by this Snoek-effect, the magnitude of frictional force on a moving dislocation caused by Snoek-effect, and the flow stress of alpha-iron in terms of this mechanism.

858. Seemann, H. J., Siol, M., and Schommer,
DAMPING PROPERTIES OF A HIGH-PURITY ALUMINUM-
COPPER ALLOY AND DURALUMINUM AT VARIOUS STAGES
OF AGING, Metall, Vol. 13, December 1959, pp. 1099-1104
(In German).

Measurements were made with samples annealed at 500° and 520° C, and quenched and aged from zero to 220° C, and damping was investigated as a function of aging temperature. Damping behavior is thought to be influenced by the precipitation of theta-phase.

859. Seemann, H. F.,
METHODS AND RESULTS OF THE MEASUREMENT OF
DAMPING IN STEELS AND NONFERROUS METALS,
Instituto del Hierro y del Acero, Vol. 13, October-December
1959, pp. 295-309 (In Spanish).

This article investigates testing procedures and equipment, application of damping studies to investigation of influence of carbon and phosphorus in aging of steel, the

theory of damping mechanism in high-purity aluminum, and the use of damping phenomena for the study of structural hardening in a four percent copper-aluminum alloy and a Duraluminum.

860. Shmatov, V. T.,
ON THE THEORY OF INTERNAL FRICTION IN INTERSTITIAL AND SUBSTITUTIONAL SOLID SOLUTIONS, Akademii Nauk, SSSR, Fizika Metallov i Metallovedenie, Vol. 7, No. 3, 1959, pp. 321-330 (In Russian).

Formulae are derived for the various parameters arising in isothermal internal friction in interstitial and substitutional solid solution, including those possessing long-range order. Good agreement with the results of pendulum damping experiments is claimed.

861. Singh, H. and Nolle, A. W.,
PRESSURE DEPENDENCE OF THE VISCOELASTIC BEHAVIOR OF POLYISOBUTYLENE, Journal of Applied Physics, Vol. 3, No. 3, March 1959, pp. 337-341.

The absorption of 4 mc/sec ultrasonic waves in polyisobutylene is measured as a function of temperature for various pressures. The extreme limits of these variables are 1 to 1400 atmospheres and -20° to 80° C, respectively.

862. Sinnott, K. M.,
SHEAR MODULUS AND INTERNAL FRICTION OF POLYMETHYL-METHACRYLATE AND POLYETHYL METHACRYLATE BETWEEN 4.2 AND 100 K, Journal of Polymer Science, Vol. 35, 1959, pp. 273-275.

The shear modulus and logarithmic decrement of internal friction of polymethyl methacrylate (I) and polyethylmethacrylate (II) were measured between 4.2 and 100 K. Since a transition occurred in II at 41 K and none occurred in I, this transition was assumed to be due to the reorientation of the ester Et group.

863. Siol, M., Dickenscheid, W., and Staats, H.,
DAMPING PROPERTIES OF METALLIC MATERIALS,
Metall, Vol. 13, December 1959, pp. 1118-1123 (In German).

This article investigates equipment used in damping measurements, relationships between relaxation and clamping, and damping properties of carbon steel, high-purity aluminum and heat-resisting alloys as a function of temperature.

864. Sittel, K.,
EARLY DETECTION OF FATIGUE IN METAL ALLOYS BY
ULTRASONICS, Nondestructive Testing, Vol. 17, May-June
1959, pp. 165-171.

This article explores fundamental aspects of fatigue, caused of attenuation of ultrasonic wave energy in metals, and possible applications of acoustical methods to the detection and measurement of dislocations during early stages of fatigue.

865. Snowdon, J. C.,
STEADY-STATE BEHAVIOR OF THE DYNAMIC ABSORBER,
Acoustical Society of America, Journal, Vol. 31, No. 8,
August 1959, pp. 1096-1103.

The resonant vibration of machinery and resiliently mounted equipment can be reduced with a dynamic absorber of suitable design. The necessary analytical and graphical information for an optimum design is presented in this paper. It is assumed that the absorber mass is attached resiliently to the vibrating item with a rubber-like material, and not with a spring and dashpot in parallel as considered in the classical theory of Ormondroyd and Den Hartog. The dynamic absorber utilizing a material with a stiffness proportional to frequency and a constant damping factor can reduce the resonant vibration of machinery and equipment items considerably. Its performance is superior to that of the classical dynamic absorber.

866. Snowdon, J. C.,
TRANSIENT BEHAVIOR OF THE DYNAMIC ABSORBER,
Acoustical Society of America, Journal, Vol. 31, No. 12,
December 1959, pp. 1668-1675.

The ability of a dynamic absorber of optimum design to reduce the transient motion of resiliently mounted equipment is discussed theoretically.

867. Sommer, W.,
ELASTIC BEHAVIOR OF POLYVINYL CHLORIDE UNDER
STATIC AND DYNAMIC STRESS, Kolloid-Zeitschrift, Vol.
167, 1959, pp. 97-131.

The stretching modulus of elasticity of unfractionated and unplasticized polyvinyl chloride was determined between 20° and 120° when stress was applied statically (time, t , = 0.1-10⁵ sec) and dynamically (frequency, f , = 10⁻⁵-10⁴ cps). Apparatus is described for automatic registration of curves from which the static modulus, the real and imaginary, components of the complex modulus, and the mechanical loss factor could be obtained.

868. Southgate, P. D.,
MEASUREMENT OF LOW VALUES OF INTERNAL FRICTION
AT ELEVATED TEMPERATURES, Journal of Scientific
Instruments, Vol. 36, No. 6, 1959, pp. 284-287.

Some features are described of an apparatus which can measure the internal friction of longitudinally resonating specimens at elevated temperatures. The apparatus uses electrostatic drive and frequency modulation detection, and operates near 100 kps at temperatures up to 1300° C. Limits of operations are discussed, and a comparison is made of the observed amplitude-dependent loss at the specimen supports with a simple theory of frictional loss.

869. Srinivasan, P.,
INTERNAL DAMPING OF THERMAL ORIGIN IN THIN WIRES,
Journal of Applied Mechanics, Vol. 26, No. 3, September
1959, pp. 456-457.

The object of this note is to study the effects of wire diameter, length, and material of the wire on its damping ability. The damping force in the wire material is assumed

to be a linear function of the strain rate and purely of thermal origin. An equation is developed relating the maximum damping (logarithmic decrement) due to thermal origin, to parameters of the wire (radius, length, and material).

870. Stiller, N.,
INTERNAL FRICTION AS A CONSEQUENCE OF A RE-ORDERING PROCESS, Am. Phys. Leipzig, Folge 7, Vol. 3, Nos. 5 and 6, 1959, pp. 283-297.

Using a torsion method, measurements of internal friction were made on alloys of silver-platinum, silver-manganese, silver-zinc, silver-magnesium, and gold-cadmium at temperatures between 20° and 500° C. In silver-zinc, silver-magnesium and gold-cadmium, two maxima were found in the range, which were related to possible mechanisms involving the re-arrangement of pairs of solute atoms. In silver-platinum and silver-manganese such maxima were not observed and the solute atoms were assumed to be statistically distributed.

871. Sumner, G. and Entwistle, K. M.,
THE STRESS-DEPENDENT DAMPING CAPACITY OF FERROMAGNETIC METALS, Iron and Steel Institute, Journal, Vol. 192, July 1959, pp. 238-245.

Stress-dependent damping arises from the irreversible movement of magnetic domain boundaries. A simple analysis using domain theory predicts a relation between stress for peak damping and magnetizing field for maximum susceptibility which is found experimentally to be valid.

872. Suzuki, T., Suzuki, K., and Kamigaki, T.,
INTERNAL FRICTION OF KCl CRYSTALS AT LOW TEMPERATURES, Physical Society of Japan, Journal, Vol. 14, No. 6, June 1959, pp. 431-440.

Ultrasonic attenuation in the megacycle range for cold-worked and for quenched KCl crystals was measured between 200° K and room temperature. A very broad relaxation band appears below 240° K for cold-worked crystals. The experiments on the anisotropy of attenuation in crystals cold-worked by uniaxial compression demonstrate that the attenuation is caused by the motion of the dislocations.

873. Thompson, D. O. and Holmes, D. K.,
DISLOCATION CONTRIBUTION TO THE TEMPERATURE
DEPENDENCE OF THE INTERNAL FRICTION AND YOUNG'S
MODULUS OF COPPER, Journal of Applied Physics, Vol.
30, No. 4, April 1959, pp. 525-541.

A study of the amplitude-independent internal friction and Young's modulus in copper from 14° K to room temperature, both before and after neutron irradiation, indicates that there are two dislocation components in these quantities.

874. Truell, R.,
NATURE OF DEFECTS ARISING FROM FAST NEUTRON
IRRADIATION OF SILICON SINGLE CRYSTALS, Physical
Review, Vol. 116, No. 4, 15 November 1959, pp. 890-892.

Precision ultrasonic velocity and attenuation of compression waves using scatter theory permit detection of upper and lower limits of size of region damaged by fast neutrons in silicon. Assuming sphericity, radii of 0.01 to 0.27 μ are found.

875. Truell, R.,
ULTRASONIC METHODS AND RADIATION EFFECTS IN
SOLIDS, Journal of Applied Physics, Vol. 30, August 1959,
pp. 1275-1278, 1321.

The various mechanisms producing damping of ultrasonic elastic waves in solids are reviewed. Particular attention is given to the changes in attenuation produced by pinning of dislocation lines. Measurements of ultrasonic attenuation in irradiated single crystals of NaCl are presented and discussed, on the assumption that the dislocation density remains constant while the radiation-displaced defects pin the dislocations.

876. Tsien, C. T.,
MECHANISM OF INTERNAL FRICTION PEAK OF INTER-
STITIAL ATOMS IN THE FACE-CENTERED CUBIC CRYSTAL,
Acta Metallurgia Sinica, Vol. 4, March 1959, pp. 69-74.

Relationships are shown between carbon content and height of the internal friction peak of carbon diffusion in pure nickel and in manganese steel containing 18.5 percent manganese. The internal friction peak induced by the interstitial atomic diffusion in the pure metal of a face-center cubic crystal is due to the rotation of the atomic pair of two neighboring atoms in the crystal lattice under the action of stress.

877. United States Bureau of Mines,
DAMPING CAPACITY - ITS MEASUREMENT AND SIGNIFI-
CANCE by J. W. Jensen, 1959, Report No. 5441.

This report was prepared as a background reference for future publications concerning the damping capacity of metals and alloys. It contains a broad description of the theory and methods of measuring damping capacity and correlates the developments of the past decade in terminology, units, and techniques.

878. Vasilenko, M. V. and Pisarenko, G. S.,
FORCED DEFLECTION-TORSION VIBRATIONS OF BARS
WHEN TAKING INTO ACCOUNT INTERNAL FRICTION,
Doklady Akademii Nauk SSSR, No. 8, 1959, pp. 883-836
(In Russian).

The joint system is investigated of two differential equations describing the linked deflection-torsion vibrations of a bar.

879. Veinblat, B. M.,
THE DAMPING OF VIBRATIONS IN FERROCONCRETE
BRIDGES, Avtomb. Dorogi, Vol. 10, 1959, pp. 20-22.

The results are reported of damping decrement measurements in ferroconcrete bridges, linked with the internal and external resistances to the vibrations. Based on the experiments the following deductions are made: the damping decrements decrease with increase in the span of the bridge, and the damping decrements in prestressed spanned constructions are considerably less than in constructions built with ordinary ferroconcrete.

880. Vekilov, Yu. Kh. and Shaskol'skaya, M. P.,
INFLUENCE OF PLASTIC DEFORMATION ON INTERNAL
FRICTION AND ON SHEAR MODULUS OF SILVER CHLORIDE,
Doklady Akademii Nauk SSSR, Vol. 128, No. 1, 1 September
1959, pp. 71-72 (In Russian).

The temperature dependence is investigated of internal friction and of shear modulus of monocrystals and of polycrystals of AgCl, caused by plastic deformation and by annealing. The results are illustrated.

881. Vidman, D. N. and Ginzburg, E. S.,
THE DEPENDENCE OF THE DAMPING DECREMENT OF
CHROMIUM STAINLESS STEEL ON ITS STRUCTURE AND
MECHANICAL PROPERTIES, Ekspluatatsion. Nadeshnost
Metalla Parosilovykh Ustanovok, Sbornik Statei, 1959, pp.
89-97.

Steels 1Kh13 consist of sorbitic pearlite, with varying amounts of intergranular ferrite or carbides. The yield strength, tensile strength, elongation, hardness, and endurance limit do not vary with the damping decrement, while an increase in the latter is accompanied by increases in the impact strength, notch plasticity, and redistribution of area in tensile testing. In fatigue tests with stresses exceeding the endurance limit, the number of cycles causing failure at a given stress increases with increasing damping decrement.

882. Vinogradov, K. N. and Ul'yanov, G. K.,
MEASUREMENT OF VELOCITY AND ATTENUATION OF
ULTRASONIC SURFACE WAVES IN SOLID MATERIALS,
Akusticheski Zhurnal, Vol. 5, 1959, pp. 290-293.

The velocity and attenuation of ultrasonic surface waves in several metals, alloys, and glasses were measured.

883. Vodsed'alek, J.,
INTERNAL FRICTION OF HEAT-RESISTANT STEELS AND
ALLOYS WITH SPECIAL REFERENCE TO CREEP CONDI-
TIONS, Hutnické Listy, Vol. 14, December 1959, pp. 1125-
1130 (In Czech).

A number of 13 percent chromium steels, unaged austenitic chromium-nickel steels and age-hardening austenitic steels are tested for damping and magneto-mechanical damping properties. Influences of creep and cycling on logarithmic decrement are investigated.

884. Wall, R. A., Sauer, J. A., and Woodward, A. E.,
THE DYNAMIC MECHANICAL BEHAVIOR OF POLY-
STYRENE: ATACTIC AND ISOTACTIC, Polymer Science,
Vol. 35, 1959, pp. 281-284.

Mechanical loss and resonant frequency as a function of temperature were obtained for crystalline isotactic (I) and

amorphous polystyrene (II) at 80° to 500° K. From 80° to 300° K, the damping values for I and II were the same; below 130° K, they were higher for II.

885. Walsh, D. F., Jensen, J. W. and Rowland, J. A.,
VIBRATION DAMPING CAPACITY OF MAGNESIUM ALLOYS,
Magnesium, February 1959, pp. 10-11.

Damping and mechanical property data for wrought alloys in the extended or hot-rolled condition and for heat-treated alloys are presented.

886. Walz, E. and Magun, S.,
THE MECHANICAL RELAXATION IN ICE-NH₄F MIXED
CRYSTALS, Zeitschrift für Physik, Vol. 157, 1959, pp.
266-274.

Single crystals of ice, containing 1.4×10^{-4} - 5.4×10^{-6} parts of NH₄F, were grown in the form of cylinders having a height and a diameter of 10 centimeters. The mechanical relaxation of these crystals was measured between zero and -120° in the frequency range 0.5 to 6 kc/sec for two kinds of deformation.

887. Washington University, Seattle, Washington,
THE EFFECT OF FREQUENCY AND PHYSICAL STRUCTURE
UPON THE SOLID DAMPING PROPERTY OF MATERIALS
by H. L. Milligan, 1959, Thesis.

Damping studies were conducted on a few plastics and several sheet and cast metals, in both the tempered and annealed condition. The specimens were mounted as cantilever beams to a shaker pot, and accelerometers were attached for instrumentation. Beam lengths were changed to obtain a range of resonant frequencies, and the vibrational energy level was varied to determine the relationship between damping and frequency at certain stress levels.

It was found that damping capacity decreases as the frequency becomes higher under conditions of equal maximum bending stress. The relationship is exponential in the frequency range 20 to 800 cps.

888. Westinghouse Electric Company,
WESTINGHOUSE DATA REPORT - NIVCO-10, Westinghouse
Corporation, 1959.

The composition, tensile properties, stress rupture properties, fatigue strength, notch impact, and damping capacity of Nivco 10 alloy are given. The damping capacity 100 ksi and 120 ksi yield strength Nivco-10 is presented for varying shear stress and for different temperatures.

889. Whiteman, I. R.,
A MATHEMATICAL MODEL DEPICTING THE STRESS-
STRAIN DIAGRAM AND THE HYSTERESIS LOOP, Journal
of Applied Mechanics, Vol. 26, No. 1, Series E, March
1959, pp. 95-100.

A model is made up of elastoplastic elements, all of which have the same value of Young's modulus E , but which have different values of yield stress. It is shown that the dimensionless tangent modulus graph E/E represents the cumulative frequency distribution of those elements which are in the elastic region. From the frequency distribution, the equations for the stress-strain diagram and the hysteresis loop can be written.

890. Wiegand, H. and Hentze, H.,
DETERMINATION OF PROPERTIES OF IRON-GRAPHITE
MATERIALS BY MEANS OF ULTRASONICS, Metall, Vol. 13,
December 1959, pp. 1110-1113 (In German).

Determination of the modulus of elasticity by measuring propagation velocity of ultrasonic waves. Elasticity as a function of deformation. Relationships between damping and elasticity modulus and its connection with elastic limit and tensile strength.

891. Wilks, J.,
THE DEPENDENCE OF INTERNAL FRICTION ON FRE-
QUENCY, Philosophical Magazine, Vol. 4, Eighth Series,
December 1959, pp. 1379-1382.

Using a model in which internal friction arises from a viscous-like damping of lengths of dislocation, anchored at each end by some form of pinning point, and vibrating with the applied stress, it can be shown that the damping should

be proportional to the frequency of the oscillations. It appears, however, that in many metals the friction varies much more slowly than the first power of the frequency. The author indicates that a simple explanation of this behavior is implied in a recent treatment by Thompson and Holmes.

892. Williams, K. J. and Entwistle, K. M.,
THE DAMPING OF QUENCH-AGING DURALUMIN VIBRATING
AT ABOUT 1 CYCLE PER SECOND, Institute of Metals,
Journal, Vol. 87, January 1959, pp. 141-145.

This article investigates damping changes during quench-aging at constant temperatures, and damping of freshly-quenched specimens during heating at constant rate, and presents experimental evidence establishing existence of two distinct damping contributions in quench-aging duralumin.

893. Winter, J. and Weinig, S.,
GRAIN-BOUNDARY ADSORPTION OF SOLUTES, Transac-
tions, American Institute of Mining, Metallurgical and
Petroleum Engineers (AIME), Vol. 215, 1959, pp. 74-82.

The grain-boundary adsorption of solutes as a function of bulk concentration and solution temperature was examined by internal-friction techniques. From the variation of the corresponding energy of activation for the phenomenon, the interaction energy of activation between solute atom and high-angle boundary was calculated.

894. Woerner, S. and Magun, S.,
MECHANICAL DAMPING OF HEAVY ICE CRYSTALS,
Naturwissenschaften, Vol. 46, No. 17, 1959, pp. 509-510
(In German).

Damping measurements were carried out in the frequency range of 0.2 to 4 kc/sec and the temperature range of -90° to 2° C. The frequency of maximum damping, f_{\max} , varied with temperature, T, according to the equation $F_{\max} = f_0 \exp(-A/kT)$. The same formula applied to light ice with the same activation energy, A, (suggesting that damping arises from diffusion of proton or deuteron vacancies) but with the frequency factor, f_0 , multiplied by 0.58.

895. Woodward, A. E. and Sauer, J. A.,
DYNAMIC MECHANICAL BEHAVIOR OF PARTIALLY
CRYSTALLINE POLYMERS, Soc. Chem. Ind. (London)
Monograph, Vol. 5, 1959, pp. 249-258.

Among the polymers studied were polyethylene (I), polytetrafluoroethylene (II), polyhexamethyleneadipamide (III), an essentially amorphous polyamide copolymer (IV), and various irradiated polyethylenes (V). For each of the materials, multiple mechanical relaxation dispersions have been observed when the dynamic modulus and internal friction have been measured from liquid nitrogen temperatures to the softening temperature.

896. Wright Air Development Center,
STEADY STATE RESPONSE OF A SIMPLE SYSTEM WITH
A HYSTERETIC SPRING, July 1959, Report No. TR 59-121.

The response of a simple spring mass system is studied. The spring characteristics are chosen to simulate hysteresis loops found for systems in which the damping is due to the energy dissipation of materials or fabricated joints. Procedures for approximate calculations are outlined and an example is given.

897. Wright Air Development Center,
BEAM VIBRATIONS WITH QUASI-ORTHOGONAL BOUNDARY
CONDITIONS by Y. C. Das, L. E. Goodman, and A. R.
Robinson, November 1959, Report No. TR 59-76.

The technique described for the analysis of linear structures subject to linear (velocity) damping at boundaries is an extension of the work of Bulgakov. Quasi-orthogonality relations which are obtained for any set of two modes permit expansion of any sufficiently smooth function in a series of eigen-functions. This fact makes it possible to complete the solution.

898. Wright Air Development Center,
DAMPING ENERGY DISSIPATION AT SUPPORT INTERFACES
OF SQUARE PLATES by T. J. Mentel and C. C. Fu, June
1959, Report No. TR 59-96.

The energy dissipation due to viscous shear forces between support interfaces of built-in square plates is

obtained for simple harmonic transverse vibration of the plates. A comparison is made with the energy dissipation due to material damping within the plates, and it is shown that the interface damping mechanism can have an overriding effect for thin plates. A preliminary design curve is presented which allows rapid evaluation of structural and material parameters which will maximize interface damping.

899. Wright Air Development Center,
STEADY STATE UNDAMPED VIBRATIONS OF A CLASS OF
NONLINEAR DISCRETE SYSTEMS by P. R. Sethna, B. E.
Fristedt, and V. G. Harvester, August 1959, Report No.
TR 59-141.

Steady state vibrations of a class of nonlinear discrete systems with an arbitrary number of degrees of freedom are studied. The coordinates of the system are first transformed to the principal coordinates corresponding to the linear part of the system. A perturbation scheme is used to obtain the solutions. Some special effects of the ratios of the linear natural frequencies on the qualitative nature of the solutions are demonstrated.

900. Wright Air Development Center,
DAMPING OF FLEXURAL VIBRATIONS BY ALTERNATE
VISCOELASTIC AND ELASTIC LAYERS by E. E. Ungar,
D. Ross, and E. M. Kerwin, November 1959, Report No.
TR 59-509.

Previous work dealing with the damping of flexural vibrations by application of single "damping tapes" consisting of metal foils and dissipative adhesives is summarized and extended to multiple tapes. A general analysis of damping due to nitrogen equal tapes is presented. The effect of using non-equal tapes is investigated for double tape applications. Suitable dimensionless parameters are used where possible in order to maintain generality.

It is shown that additional tapes provide a considerable increase in damping at low frequencies, but only a very small increase at high frequencies.

901. Wright Air Development Center,
THE EFFECT OF CONFIGURATIONAL ADDITIONS USING
VISCOELASTIC INTERFACES ON THE DAMPING OF A
CANTILEVER BEAM by J. S. Whittier, May 1959, Report
No. TR 58-568, ASTIA Document No. 214381.

A quasi-static analysis of a cantilever beam damped by an added configuration involving viscoelastic interfaces is presented. Optimum values of viscoelastic damping are calculated and compared with calculated values of damping due to hysteresis of the structural material of a plain beam. Experimental data show fair agreement with the theory both as to order of magnitude and trends toward optimum values.

902. Yakovlev, A. P.,
THE INFLUENCE OF THE FORM OF THE TRANSVERSE
OSCILLATION ON THE DAMPING FACTOR, Zavodskaya
Laboratoriya, 1959, pp. 206-208.

Specimens of three sizes were prepared from metallo-ceramic materials (3.5 x 13 x 196, 4 x 15 x 295, and 4 x 15 x 450 millimeters). A description of the set-up and of the oscillator is given. It can be seen from the graphs obtained that for the same maximum load the logarithmic decrement is reduced, with an increase in dimension in the form of the transverse oscillations. Thus, a decrease of approximately 14 percent occurs with the second specimen, and a further decrease of approximately 17 percent with the third. In analyses of machine components for inherent resistance to vibration, it is necessary to take into account the logarithmic decrement and also the increase in the complexity of the form of the transverse oscillations.

903. Yeh-Ning, W., and Chiang-Chung, C.,
THE BEHAVIOR OF INTERNAL FRICTION ASSOCIATED
WITH THE PROCESS OF MARTENSITE-TYPE TRANSFOR-
MATION, Acta Physica Sinica, Vol. 15, July 1959, pp. 341-
352.

Alloys of iron with 17.5 and 12.8 percent manganese were examined with a torsion pendulum, and peaks were observed in martensite and reverse martensite transformation regions. The mechanism is discussed.

904. Zdorovets, A. S.,
THE EFFECT OF STRESSED STATES ON THE DIFFUSION
PROCESS IN BINARY SOLUTIONS, Ukrain. Fiz. Zhur.,
Vol. 4, 1959, pp. 357-362.

A general equation is derived for the free energy of a solid solution that is under stress, in which the atoms diffuse at a finite diffusion rate. The equation is of wider validity than the one by Lyubov and Fastov. This more comprehensive equation makes it possible to solve the problem of lateral elastic wave propagation in a relaxing solid solution. The damping constant, the rate of propagation, and the absorption constants for the various wave lengths can now be stated.

905. Ziegler, H.,
AN ADJUSTABLE DAMPING COMPONENT FOR MACHINE
TOOLS, Forsch. -und-Konstr. Wzm. (FoKoMa), Vol. 4,
1959, pp. 59-61 (In German).

The author uses a two degree of freedom spring dashpot model to illustrate how chatter in machine tools can be overcome. He illustrates a method of incorporating the principle in an actual design. Resonance amplification for the working model was cut by a factor of three by adding the second mass and viscous damper.

906. Akita, T.,
RELATION BETWEEN ROCKWELL HARDNESS AT HIGH TEMPERATURE AND CROSS-LINDING DENSITIES OF THERMOSETTING RESINS, Kobunshi Kagaku, Vol. 17, 1960 ("Dynamic Rheological Properties Measured by the Free Torsional Oscillation Method", pp. 738-743).

The transition temperature of Rockwell hardness, T_R , was compared with the temperature of maximum damping, T_λ , and the ester resins of various cross-linking d. The effects of plasticizers on the rheological properties of polyesters and polyvinyl chloride were also investigated.

907. Alers, G. A.,
ELASTIC MODULI OF VANADIUM, Physical Review, Vol. 119, 1960, pp. 1532-1535.

By the technique of zone melting of electron bombardment, single crystals of vanadium were grown in a high vacuum. Two crystals were prepared from seeds such that their lengths were parallel to the [100] and the [110] crystal directions. With these orientations, the elastic moduli were measured directly from 4.2° to 300° K by the ultrasonic pulse-echo technique. The moduli were used to calculate a phonon frequency distribution which is compared with the distribution measured by slow-neutron scattering.

908. Angus, H. T.,
MECHANICAL, PHYSICAL AND ELECTRICAL PROPERTIES OF CAST IRON, Transactions, Physical and Engineering Properties of Cast Iron, British Cast Iron Research Association, Alvechurch, Birmingham, England, Part II, 1960, pp. 39-192.

This article investigates tensile and impact strength, fatigue resistance, thermal conductivity, magnetic properties, damping capacity and coefficient of friction and other properties of cast iron.

909. Aoki, K., Sekino, S., and Fujishima, T.,
APPLICATIONS OF INTERNAL FRICTION METHOD TO
THE STUDIES OF IRON AND STEEL. Pt. 2. RECOVERY
OF INTERNAL FRICTION OF LOW-CARBON STEELS AFTER
COLD WORK, Japan Institute of Metals, Journal, Vol. 24,
April 1960, pp. 246-249.

Commercially pure iron and aluminum-killed deep-drawing steel sheet were cold worked by the tensile test machine. The Koster effects thus obtained were analyzed, using the Granato-Lucke and Cottrell-Bilby theories. Recovery of internal friction can be explained to the Granato-Lucke theory in relation to the diffusion of carbon, nitrogen atoms and their pinning dislocations.

910. Ashmarin, G. M.,
HIGH-TEMPERATURE INTERNAL FRICTION OF THE IRON-VANADIUM ALLOYS, Relaksatsion. Yavleniya v Metal. i Splavakh, Moskov. Inst. Stali, Trudy Mezhevuz. Soveshchaniya, 1960, pp. 146-153.

The internal friction of iron-vanadium alloys was measured with a torsional pendulum at one cps. The wire samples, containing 0.3 percent, 0.81 percent, 0.93 percent, 4.3 percent, 8.08 percent, 11.10 percent, 13.83 percent, 19.28 percent and 23.24 percent vanadium, were hardened and annealed. No relaxation was observed in alloys containing less than 12 atomic percent vanadium (in annealed condition) during changes of temperature less than or equal to 650°. At 12 percent vanadium the peak of internal friction appeared at 600°.

911. Atomic Energy Commission,
DISLOCATION INTERACTION AND THE HIGH-TEMPERATURE MECHANICAL PROPERTIES OF MgO CRYSTALS by R. Chang, 1960, Report No. NAA-SR-5684, pp. 1-15.

The high-temperature yield stress and inelastic properties of MgO crystals were measured. Both the yield-stress data and internal-friction data yield a binding energy between the defect, presumably a positive ion vacancy, and a dislocation of approximately 0.3 electron volt.

912. Awatani, J., Sakagami, Y., and Akai, H.,
AN INTERNAL FRICTION STUDY OF ORIENTED POLY-
ETHYLENE, Memoirs, Institute of Scientific and Industrial
Research, Osaka University, Vol. 17, 1960, pp. 99-105.

A reed-vibration apparatus was constructed for measurements of dynamic properties of polymers from -70° to 250° . Effects of the plastic deformation and the heat-treatment on the internal friction and Young's modulus were investigated for high- and low-pressure polyethylene.

913. Baccaredda, M. and Butta, E.,
MECHANICAL AND DYNAMIC PROPERTIES AND GLASS-
TRANSITION TEMPERATURES IN CIS-POLYBUTADIENE,
Chimie et Industrie, Milan, Vol. 42, 1960, p. 978.

Glass-transition temperatures are determined for polybutadiene, containing approximately 95 percent cis-1, 4-bonds, by measuring sound velocity and internal dissipation at 5 to 20 kc/sec and -170° to -20° C by an electrostatic method. A glass transition exists at -95° C for cis-polybutadiene. This is compared with the transition at approximately -50° C observed with randomly polymerized polybutadiene, and the effect on physical properties is discussed.

914. Balalaev, Y. F.,
STRUCTURAL VARIATIONS AND THE STRENGTH OF STEEL
UNDER HIGH FREQUENCY CYCLIC LOADING, Metalloved
i Term. Obrabotka Metal, No. 4, 1960, pp. 41-45.

A special resonance device was constructed for extension compression tests at frequencies of 17 to 20 kc/sec. Tests showed that increasing the frequency to 20 kc/sec had an inconsiderable effect on the endurance limit of the steel. The testing of untempered steel specimens at high frequency leads to local heating up to 1200° C due to microplastic internal friction. The microstructural variations confirm the theory of dislocations. In low-carbon steels in the zone of heating to 900° C, the isolated ferrite particles orient themselves in mutually perpendicular planes in the direction of the action of the maximum tangential stresses.

915. Barber, S. W., Forry, K. E., and Degering, E. F.,
EFFECTS OF ELECTRON BOMBARDMENT ON ELASTICITY
AND MECHANICAL DAMPING OF CERTAIN GLASSES,
Journal of American Ceramics Society, Vol. 43, No. 8, 1960,
pp. 408-412.

A borosilicate glass and a lead-containing silicate glass were exposed to various dosages of two million-electron-volt electrons, and the effects on the logarithmic decrement were noted. Quantitatively, tangent δ was increased 10 to 15 percent in the borosilicate and 30 to 60 percent in the lead glass, and the corresponding decreases in rigidity were of the order of 0.4 and 2 percent, respectively. In both glasses the mechanical effects and the associated brownish color anneal out in about 20 hours at 500° F. Completely unexpected effects included (1) changes in the shape of tangent δ versus temperature curves caused not only by thermal treatment but also by changes in period of the pendulum, and (2) fine structure in tangent δ versus temperature maxima due to sodium ion diffusion.

916. Bastien, P.,
EFFECT OF HYDROGEN ON WELDED CAST AND FORMED
STEEL, Zvaracsky Sbornik, Vol. 9, March 1960, pp. 345-
366.

This article covers: (1) effects of hydrogen on the flaking of forged or rolled steel, (2) brittleness of welds containing hydrogen, and (3) internal friction, elastic and plastic deformation and tensile properties as functions of the hydrogen present and its distribution in the metal in the form of protons, atoms, or molecules. A literature review is included.

917. Bastien, P. and Margerand, R.,
CRYSTALLOGRAPHIC RELATIONSHIPS BETWEEN THE
GAMMA PHASE AND THE ALPHA PHASE RESULTING
FROM WORK-HARDENING OF AN UNSTABLE AUSTENITE,
Mémoires Scientifiques de la Revue de Métallurgie, Vol. 57,
October 1960, pp. 778-786.

This article presents: (1) the orientation relations between austenite and alpha phase produced by wire-drawing operations on a high-chromium steel, (2) the relationship between percentage of alpha phase formed and the values of

modulus of elasticity and internal friction, (3) a proposal of a theory of gamma-alpha transformation by workhardening using Bain's model and concept of dislocation-transformation, and (4) a discussion of slip mechanism in cases of deformation by compression and by drawing.

918. Bauer, C. L. and Gordon, R. B.,
DISLOCATION DAMPING EFFECTS IN ROCK SALT, Journal of Applied Physics, Vol. 31, 1960, pp. 945-949.

Internal-friction measurements made as a function of strain amplitude on deformed NaCl single crystals were followed by elastic-modulus measurements made during x-irradiation by the same crystals. Etch-pit ds. also were determined. These data were used to evaluate the constants in a theory of Granato and Lucke permitting the calculation of the average length of the dislocation segments, L , which vibrate under an applied alternating stress. An independent determination of the magnitude of L was made from the elastic modulus data using a method developed by Gordon and Nowick.

919. Beaulieu, C. E., Dube, A., and Letendre, G.,
ROOM-TEMPERATURE RECOVERY OF INTERNAL FRICTION AND ELASTIC CONSTANTS IN FRESHLY QUENCHED STEELS, Transactions, Metallurgical Society of American Institute of Mining, Metallurgical and Petroleum Engineers (AIME), Vol. 218, June 1960, pp. 558-566.

A study is presented of the time dependence of internal friction and modulus of rigidity in freshly-quenched steels at room temperature, and the effects of frequency, composition, and various thermal treatments. The kinetic laws observed cannot be fully explained by the so-called first stage of tempering and the transformation of retained austenite. It is suggested that the observed phenomena are due to the progressive immobilization of dislocations introduced by the martensitic transformations.

920. Belov, K. P., Kataev, G. I., and Levitin, R. Z.,
ANOMALIES IN INTERNAL FRICTION AND MODULUS
OF ELASTICITY IN FERROMAGNETICS NEAR THE CURIE
POINT, Zhurnal Eksperimental'noi i Teoreticheskoi Fiziki,
Vol. 10, April 1960, pp. 670-673.

The temperature dependence of Young's modulus and internal friction measured in elinvar (iron-nickel-chromium) and coelinvar (iron-cobalt-chromium) alloys, and in nickel and nickel-zinc ferrite is discussed. An internal-friction peak, a jump in Young's modulus, and an effect of the magnetic field on the dynamic Young's modulus have been detected near the Curie point in alloys possessing the large paraprocess magnetostriction. It is shown that these phenomena are due to redistribution of spins within the domains induced by elastic stresses.

921. Belov, K. P., Katayev, G. I., and Levitin, R. Z.,
INTERNAL-FRICTION ANOMALIES IN FERROMAGNETS
AND ANTIFERROMAGNETS NEAR THE CURIE POINT,
Journal of Applied Physics, Supplement, Vol. 31, No. 5,
May 1960, pp. 153-156.

Measurements of the temperature dependence of internal friction were carried out in a number of ferromagnets and antiferromagnets. Sharp peaks of internal friction were found in ferromagnetic alloys (invars) and antiferromagnets (MnO, etc.), which have a large spontaneous deformation of the crystalline lattice near the Curie point. The thermodynamic theory of second-order phase transitions is used to interpret this phenomenon.

922. Belov, K. P. and Levitin, R. Z.,
MAGNETOELASTIC PHENOMENA IN ANTIFERROMAGNETS,
Ferrity, Fiz. i Fiz. -Khim. Svoistva, Doklady 3-go [Tret' ego] Vsesoyuz. Soveshchaniya, 1960, pp. 78-82.

Young's moduli and internal friction of polycrystalline antiferromagnetic compounds of NiO and Cr₂O₃ were measured by a resonance method by applying piezo-quartz vibrations of approximately 10⁵ cps and electrodynamic vibrations of approximately 10³ cps.

923. Bell Telephone Laboratories, Incorporated, Murray Hill, New Jersey,
THE DAMPING CAPACITY OF SOME GRANULAR SOILS,
1960, 26 pp.

A modified triaxial compression apparatus has been used to determine the hysteresis loop in the stress-strain curve during forced cycling of several granular soil samples. The effects of static triaxial stresses, of magnitude and frequency of the uniaxial cycling stresses on the chord modulus, the dissipated energy, and the damping capacity of the soil samples are shown.

924. Bergen, J. T., Editor,
VISCOELASTICITY-PHENOMENOLOGICAL ASPECTS,
New York, New York, Academic Press, Inc., 1960, 150 pp., illustrations.

Seven papers presented at a symposium sponsored by the Armstrong Cork Company, and held at its Research and Development Center, Lancaster, Pennsylvania, comprise the book. The objective of the book is to elucidate the role of structural features of polymeric substances in determining the mechanical behavior of such materials.

925. Besnard, S.,
NEW PHYSICAL, MECHANICAL, AND MAGNETIC PROPERTIES OF ZONE-MELTED IRON, Proceedings, Colloq. Intern. Nouvelles Propriétés Phys. Chim. Métaux Très Haute Pureté, Paris, 1960, pp. 129-143.

Properties and effects studied included recrystallization, grain size, polygonization, oxygen solubility and oxide-nuclei formation, hydrogen solubility, low-temperature electrical resistivity and brittleness, internal friction, elongation, aging, magnetic permeability, coercive force, and hysteresis loss.

926. Bishop, R. E. D. and Johnson, D. C.,
THE MECHANICS OF VIBRATION, Cambridge University Press, 1960.

Not abstracted.

927. Bode, E.,
EXPERIENCES ON THE RELAXATION OF NONELASTIC
DEFORMATION PERSISTING AFTER STATIC DEFORMATION
ON THE CASE OF PURE SILVER, Proceedings, Internal
Friction of Metals, France, 1960, pp. 89-92.

This article presents a graphic representation of relationship of internal friction to relaxation time and temperature (139° to 198° C) and stress time in static deformation and relaxation of annealed pure silver wire. Also study of mechanisms of internal friction including creep, microcreep, dislocation movement, impurity diffusion, and gliding.

928. Bömmel, H. E. and Dransfield, K.,
EXCITATION AND ATTENUATION OF HYPERSONIC WAVES
IN QUARTZ, Physical Review, Vol. 117, 1 March 1960, pp.
1245-1252.

A method for the generation and detection of hypersonic waves is discussed in some detail together with some absorption measurements in quartz. Further measurements of the hypersonic absorption in quartz at different crystal orientations and after neutron irradiation are reported.

929. Bordoni, P. G.,
CALCULATION OF RELAXATION SPECTRA, Internal
Friction of Metals, France, 1960, pp. 49-55.

This article presents theoretical calculations for determining the effect of relaxation time and intensity, and dislocations and elastic energy dissipation on relaxation spectra and the influence of temperature, frequency and amplitude on elastic energy dissipation. Copper and gold are used as examples.

930. Borisova, N. S. and Rozenberg, V. M.,
EFFECT OF INTERGRAIN STRUCTURE OF AUSTENITE
ON INTERNAL FRICTION AND CREEP OF THE ALLOY,
Ralaksatsion, Yavleniya v Metal. i Splavakh, Moskov. Inst.
Stali, Trudy Mezhvuz. Soveshchaniya, 1960, pp. 241-250.

The change of structure, caused by direct and back martensite transformation in iron alloy containing 28 percent nickel and 0.7 percent titanium, resulted in increased deformation at creep under the action of very small stresses.

Subsequent heating to 800° resulted in further increase of deformation, but heating above 800° decreased deformation. The internal friction changes with pretreatment temperature in the same way.

931. Bratina, W. J. and Mills, D.,
INVESTIGATION OF RESIDUAL STRESS IN FERROMAGNETICS USING ULTRASONICS, Nondestructive Testing, Vol. 18, March-April 1960, pp. 110-113.

The residual stress in SAE 1020 steel bars, annealed and deformed, can be evaluated quantitatively by employing the changes in absorption of ultrasound. A Sperry ultrasonic attenuation comparator is used. Micro-eddy currents or magnetic mechanisms account for the observed decrease in attenuation.

932. Bratina, W. J., Martius, U. M., and Mills, D.,
MAGNETIC CONTRIBUTION TO THE ULTRASONIC ATTENUATION IN ANNEALED AND DEFORMED STEEL (SAE 1020), Journal of Applied Physics, Supplement to Vol. 31, May 1960, pp. 241-242.

The absorption of ultrasound is investigated in low-carbon steel as a function of elastic strain applied in the presence of constant magnetic fields. The observed changes are interpreted in terms of magneto-mechanical damping.

933. Brown, C. S.,
INTERNAL FRICTION IN SYNTHETIC QUARTZ, Proceedings, Physical Society, Great Britain, Vol. 75, March 1960, pp. 459-460.

Measurements of internal friction in synthetic quartz as a function of growth rate are discussed. Crystals were grown at rates varying from 0.10 to 0.55 millimeters per day. It was found that the internal friction in synthetic quartz approaches that in natural quartz at growth rates below 0.15 millimeters per day. In crystals grown on different seed orientations by slightly varying processes, it was found that the losses were relatively independent of the growth process for a given growth rate. For applications such as frequency standards where highest possible Q is required, the crystals should be grown at low growth rates.

934. Brown University, Providence, Rhode Island,
A THEORY FOR THE OCCURRENCE OF INTRINSIC RESONANCES IN STRESSED SOLID MATERIALS, December 1960, Office of Naval Research Project NR-064-424, Contract Nonr 562(20), TR 21.

Recent experimental work on the measurement of the compliance of initially stressed materials has supplied strong evidence that at least some of the additional resonances (i. e., those not predicted by classical theory, and, specifically, those observed by E. R. Fitzgerald), are inherent in the material. A theory is presented to explain these resonances and the low values of the elastic modulus obtained with the Fitzgerald apparatus. The resonance is viewed as self-excited oscillations caused by nonlinear characteristics of the motion of dislocations in the materials.

935. Bruner, L. J.,
LOW-TEMPERATURE INTERNAL FRICTION IN FACE-CENTERED CUBIC AND BODY-CENTERED CUBIC METALS, Physical Review, Vol. 118, No. 2, 15 April 1960, pp. 399-410.

Data on the anelasticity produced by plastic deformation in various face-centered cubic and body-centered cubic pure metals and alloys are reported. Face-centered cubic materials studied at temperatures from 4.2° to 300° K include copper, aluminum, and aluminum with 0.25 atomic percent copper. Body-centered cubic systems are iron, niobium, and β -brass. Bordoni peaks are observed in copper and aluminum but are not found in either strain aged aluminum-copper alloys or pure iron. A peak observed in niobium at 173° K is not believed to be a Bordoni type. Unexplained low-temperature internal friction peaks are also observed in β -brass. A new mechanism is proposed for dislocation relaxation in which the essential feature is the thermally activated motion of paired partial dislocations between vacancy pinning points.

936. Bungardt, K. and Preisendanz, H.,
DAMPING AND MODULUS OF SHEAR OF ZIRCONIUM AND ZIRCONIUM-HYDROGEN ALLOYS, Zetischrift für Metallkunde, Vol. 51, 1960, pp. 280-289.

The damping capacity of pure zirconium showed a first maximum at 575°, displayed a steep increase when 700° was

reached, and a second maximum at 860°. When cooled, the damping curve showed a similar behavior; this indicated that the underlying processes are reversible. The phenomena observed can be explained through diffusion processes during phase changes. The experiments were extended to zirconium-hydrogen alloys. A damping maximum was found between 500° and 600°, therefore, similar to that for pure zirconium, only that considerably higher damping capacity values were observed. It is believed that the changes can be attributed to zirconium hydride formation, as Koster demonstrated it in the titanium-hydrogen system. Further damping measurements were carried out at lower temperatures and maxima established at 5° and -45°.

937. Campbell, B. W.,
ELASTOMERS APPLIED TO STRUCTURAL DAMPING,
American Society of Mechanical Engineers, Paper No. 60-
Rp-19, 1960, 5 pp.

Although primarily a review of the use of constrained damping layers to inhibit excessive vibration in structures, this paper gives some data on a BTR elastomer (never identified) which has many of the properties of an "ideal" material and some areas in which improvement can be sought. In this report, its use is confined to the "sandwich" layer of a three-ply laminate. Damping is specified in terms of the complex shear modulus.

938. Caughey, T. K.,
RANDOM EXCITATION OF A SYSTEM WITH BILINEAR
HYSTERESIS, Journal of Applied Mechanics, Vol. 27, No. 4,
December 1960, pp. 649-652.

An analysis is made of a system with bilinear hysteresis to random excitation. It is shown that for moderately large inputs, the additional damping created by the bilinear hysteresis decreases the mean squared deflection compared with that for a linear system with the same viscous damping. However, for large inputs, the decrease in the stiffness of the system for the bilinear hysteresis causes the mean squared deflection to increase over that for the equivalent system.

939. Caughey, T. K.,
SINUSOIDAL EXCITATION OF A SYSTEM WITH BILINEAR
HYSTERESIS, American Society of Mechanical Engineers,
Paper No. 60-APM-8, Journal of Applied Mechanics, Vol.
27, No. 4, December 1960, pp. 640-643.

Many physical systems exhibit bilinear hysteresis. Such behavior may be caused by the presence of Coulomb friction in the system or may be due to the elastoplastic behavior of the material in the system. This paper analyzes the response of a single-degree of freedom oscillator, having bilinear hysteresis, to sinusoidal excitation. The stability of the resulting motion is analyzed in the case of weak damping.

940. Chambers, R. H. and Shultz, J.,
LOW-TEMPERATURE STRESS-RELAXATION IN PLAS-
TICALLY DEFORMED POLYCRYSTALLINE NIOBIUM,
Acta Metallurgica, Vol. 8, August 1960, pp. 585-587.

Observations of stress-relaxation absorption peaks at low temperatures are related for a plastically deformed body-centered cubic metal. Acoustic energy absorption peaks for frequencies in the tens of kilocycles were observed at 10° and 165° K in plastically deformed, polycrystalline niobium. Measurements of internal friction were made at 4° to 300° K by a resonant-bar technique in which alternating longitudinal stress at 10 to 100 kc/sec was employed. The use of electromagnetic transducers permitted measurements at strain amplitudes of 10^{-8} to 10^{-4} .

941. Chambers, R. H. and Smoluchowski, R.,
TIME-DEPENDENT INTERNAL FRICTION IN ALUMINUM
AND MAGNESIUM SINGLE CRYSTALS, Physical Review,
Vol. 117, 1960, pp. 725-731.

Magnesium and aluminum single crystals subjected to varying amounts of oscillatory strain of audio frequency were investigated by measuring the strain amplitude-dependent complex dynamic mechanical modulus at audio-frequencies as a function of temperature and time.

942. Chang, R.,
PHASE TRANSFORMATIONS, TWINNING, AND ANELASTIC
PHENOMENON ASSOCIATED WITH ZIRCONIUM DIHYDRIDE,
Journal of Nuclear Materials, Vol. 2, No. 4, 1960, pp. 335-
340.

The atom movements and crystallography of cubic to tetragonal transformation in ZrH_2 are studied and discussed according to the phenomenological theories of Bowles and MacKenzie and of Wechsler, Lieberman, and Read. The large internal-friction peak found in $ZrH_{1.92}$ (but absent in $ZrH_{1.6}$) suggests that it is associated with a stress-induced twin interface motion. The relaxation phenomenon appears to be controlled by a diffusion process, presumably that of hydrogen, with an activation energy of about 20,000 calories per mole.

943. Chesapeake Instrument Co., Shadyside, Maryland,
DYNAMIC MECHANICAL PROPERTIES OF MATERIALS
FOR NOISE AND VIBRATION CONTROL by E. J. Cook,
J. A. Lee, E. R. Fitzgerald, and J. W. Fitzgerald,
January 1960, Report No. 101.

Concepts of complex dynamic moduli and compliances are summarized. Material data is presented.

944. Chick, R., Anderson, G., and Truell, R.,
ULTRASONIC ATTENUATION UNIT AND ITS USE IN MEASURING ATTENUATION IN ALKALI HALIDES, Journal of Acoustical Society of America, Vol. 32, February 1960, pp. 186-193.

An instrument for measurement of ultrasonic attenuation and velocity in the frequency range from 5 to 200 mc/sec is described. The unit incorporates a pulse radio frequency oscillator, superheterodyne receiver, exponential waveform generator, precision time delay generator (useful in velocity measurements), cathode-ray tube display circuits, and appropriate synchronization circuits. Ultrasonic attenuation measurements made in single crystals of NaCl and KCl during deformation and recovery at several temperatures are reported.

945. Clark, J. W. and Hagel, W. C.,
INFLUENCE OF STATIC STRESS AND TEMPERATURE ON
INTERNAL DAMPING, Transactions, American Society for
Metals, Vol. 52, 1960, pp. 95-115.

Internal damping of fixed-beam AISI 403, titanium and ferromagnetic austenitic alloys at vibratory stresses from zero to 35,000 psi and at static tension stresses from zero to 19,000 psi in the temperature range of 75° to 1100° F. Titanium shows very low internal damping under all test conditions. Although damping of ferromagnetic austenitic alloys decreases less rapidly with increasing temperature than it does in the case of AISI 403, the influence of static stress of magnetic fields causes a more drastic reduction.

946. Coale, C. W.,
THE ROLE OF DAMPING IN SPACE STRUCTURES,
Aerospace Engineering, Vol. 19, No. 5, May 1960, pp. 50-51.

It can be said that the role of damping in space structures will be the same as in more conventional structures (i. e., to attenuate dynamic motions and dissipate energy). However, the environment and type of structure will present a radically different problem. The state of knowledge of damping is insufficient at present to allow accurate dynamic analysis of damped structures. Thus, research in the area of structural damping is urgently needed.

947. Cochardt, A.,
DEVELOPMENT OF A FERROMAGNETIC COBALT-BASE
HIGH-TEMPERATURE ALLOY, Transactions, American
Society for Metals, Vol. 52, 1960, pp. 914-928.

Damping behavior, aging characteristics, creep and fatigue properties and oxidation resistance of precipitation-hardened alloys with titanium and 62 percent to 88 percent cobalt. Optimum composition range of these alloys for blade material in steam turbines is 22 percent to 24 percent nickel, 1.8 percent to 2.0 percent titanium, 0.15 percent to 0.25 percent aluminum and the balance cobalt.

948. Codd, I. and Petch, N. J.,
DISLOCATION-LOCKING BY CARBON, NITROGEN AND
BORON IN α -IRON, Philosophical Magazine, Vol. 5, No. 49,
January 1960, pp. 30-42.

It is shown experimentally that nitrogen-locking is appreciably stronger than carbon-locking. This is contrary to the customary assumption and it is suggested that there may be chemical as well as elastic interaction with the dislocations. Boron is found to produce even stronger locking than nitrogen. These variations in the locking strength alter the ductile-brittle transition temperature. The stronger the locking, the higher is the transition temperature.

949. Collette, G.,
EVALUATION OF INTERNAL FRICTION PEAKS AS INTER-
ACTIONS BETWEEN ATOMS OF CARBON AND MOLYB-
DENUM IN VARIOUS IRON-MOLYBDENUM-CARBON
ALLOYS, Comptes Rendus, Vol. 251, 1960, pp. 2017-2019.

Three peaks appear in the internal friction-temperature curve of alloys containing 1.02 percent to 3.53 percent molybdenum. Measurements were made on a hysteresis meter at a fixed period of 4.6 ± 0.1 second. One peak appeared at 10° owing to nitrogen, one at 18° owing to the interaction of carbon and molybdenum, and one at $26-7^\circ$ owing to carbon dissolved in alpha-iron.

950. Collette, G.,
THE TRANSITORY INCREASE IN THE INTERNAL FRIC-
TION DURING THE ISOTHERMAL PRECIPITATION OF
CARBON IN AN IRON-CARBON ALLOY, Comptes Rendus,
Vol. 251, 1960, pp. 2930-2932 (In French).

The peaks in the internal friction of a steel containing 0.0092 percent carbon, which appears at 27.5° , vary according to the temperature of the heat treatment. When the temperature is above 600° , the carbon is first precipitated in the metastable state of the iron and then redissolves in the stable cementite phase. When the heat treatment is carried out below 600° the curve shows no peak, since only one phase exists, with the nuclei of cementite remaining in the ferrite.

951. Collette, G. and Funakubo, H.,
STUDY OF TRANSITORY INCREASE OF INTERNAL FRICTION OBSERVED IN COPPERS OF DIFFERENT PURITY AFTER ANNEALING AND QUENCHING, Proceedings, Internal Friction of Metals, France, 1960, pp. 111-122.

Influence of heat treatment temperature (23° to 1050° C) and time, shearing modulus time, recrystallized structure, grain size and purity on coefficient of internal friction in machined and electrolytically polished electrolytic copper foils of varying purity.

952. Conte, R., Dreyfus, B., and Weil, L.,
PLASTIC TORSION OF IRON WHISKERS AT 300-20° K, Comptes Rendus, January 1960, p. 250.

Relaxation processes not observed in bulk metal are described.

953. Cox, W. P., Isaksen, R. A., and Merz, E. H.,
DYNAMIC MECHANICAL MEASUREMENT OF Mn, Journal of Polymer Science, Vol. 44, 1960, pp. 149-154.

The number--average molecular weight manganese, as well as the viscosity ratio--can be estimated from mechanical measurements of a polymer in the solid state by use of a dynamic torsion pendulum. A consideration of a four-element spring-and-dashpot model indicated that the observed relation has a basis in linear viscoelastic theory.

954. Crussard, C., Saada, G., and Philibert, J.,
INTERNAL FRICTION OF METALS, l'Institut de Recherches de la Sidérurgie Française, Saint-Germain-en-Laye, 1960, 169 pp.

Study of relationship of internal friction to relaxation, hysteresis, internal friction, damping effect, creep resistance, activity of dislocations, inserted atoms, vacancies and point defects in heat treated, cold deformed, neutron irradiated, demagnetized ferrous and nonferrous metals and alloys. Use of creep, damping effect, internal friction and dislocation resonance measurement tests.

955. Dabosi, F.,
INFLUENCE OF PURITY OF IRON ON ITS INTERNAL
DAMPING, Proceedings, Internal Friction of Metals, France,
1960, pp. 123-126.

This paper presents determination of effects of torsion amplitude from zero to 50° C, and metal purity and dislocation mobility on the internal damping of heat-treated zone-melted iron, Armco iron and electrolytic iron wires, by torsion pendulum.

956. Dabosi, F. and Talbot, J.,
INFLUENCE OF A MAGNETIC FIELD ON THE DAMPING
OF SPECIMENS OF IRON OF VARYING PURITY, Comptes
Rendus, Vol. 250, March 1960, pp. 2025-2026.

It is shown that displacement of the block walls has a considerable influence on damping.

957. Dashkovskii, A. I., Evstyukhin, A. I., and Savitskii, E. M.,
APPARATUS FOR MEASURING INTERNAL FRICTION IN
METALS AND ALLOYS, Met. i Metalloved. Chistykh Metal.,
Sbornik Nauch. Rabot, No. 2, 1960, pp. 207-213.

The torsion-balance method was used, and damping in vacuum of vibrations (of small amplitude) in a freely hanging wire or rod specimen were registered photographically. Wires up to 0.5 millimeters in diameter and rods up to 4 millimeters in diameter and 350 millimeters long could be tested at up to 1600°.

958. Dashkovskii, A. I., Evstyukhin, A. I., Savitskii, E. M.,
and Skorov, D. M.,
INTERNAL FRICTION IN URANIUM, Atomnaya Energiya,
Vol. 9, No. 27, 1960.

Studies have been made of the temperature dependence of internal friction and the shear modulus in uranium. The internal friction in α -uranium depends on the heat treatment and is reduced after annealing in the β and γ regions. Each polymorphous modification of uranium in the temperature ranges for its existence has its own value of internal friction.

959. Dashkovskii, A. I., Evstyukhin, A. I., Savitskii, E. M., and Skorov, D. M.,
TEMPERATURE DEPENDENCE OF INTERNAL FRICTION AND SHEAR MODULUS OF URANIUM, Met. i Metalloved. Chistykh Metal., Sbornik Nauch. Rabot, No. 2, 1960, pp. 224-228.

Experiments were performed with the method of torsion vibrations of small amplitude at a frequency of two vibrations per second. Uranium annealed at 630° for 30 minutes shows a peak at 100° for which no explanation has been found. At 300° there is a minimum of internal friction, thereafter there is a sharp increase. Uranium annealed at 680° for 30 minutes and thereafter cooled slowly shows a slight decrease in values of Q^{-1} from room temperature to about 300°, with sharp increase afterwards. The peak at 100° and the bend at 500° are absent.

960. Dashkovskii, A. I. and Savitskii, E. M.,
TEMPERATURE DEPENDENCE OF INTERNAL FRICTION, NORMAL ELASTICITY MODULUS, AND SHEAR MODULUS FOR ZIRCONIUM, NIOBIUM, AND ALLOYS OF ZIRCONIUM WITH NIOBIUM, Met. i Metalloved. Chistykh Metal., Sbornik Nauch. Rabot, No. 2, 1960, pp. 214-223.

Wire specimens were made of zirconium, niobium, and alloys of zirconium with 1.0 percent, 1.5 percent, 2.0 percent, 2.5 percent, and 4.0 percent niobium, while rod specimens were made also of zirconium, niobium, and zirconium alloys with 1.0 percent, 2.0 percent, 2.5 percent, 5.0 percent, and 10 percent niobium. Measurements of internal friction were sensitive to phase transformations and could be used for their investigation and for the determination of phase diagrams. For zirconium the curve of internal friction was at its maximum at 250° to 300°, caused by the precipitation of hydride of zirconium, another maximum at 450° to 600° was connected with relaxation along boundaries of grains; still another maximum at 860° to 865° was caused by polymorphic transformation.

961. Dautreppe, D.,
MAGNETIC AFTER-EFFECT OF DEFECTS CREATED BY
NEUTRON IRRADIATION OF PURE IRON, Proceedings,
Internal Friction of Metals, France, 1960, pp. 167-168.

An irradiation of pure iron by neutrons at 30° C has produced a diffusion based magnetic after-effect, with an activation energy for the movement of the defects so created of 1.2 electron volts. After irradiation at 78° K, another after-effect has been found where the activation energy was 0.3 electron volts.

962. Davidson, H. W. and Losty, H. H. W.,
AN INTERPRETATION OF THE MECHANICAL BEHAVIOR
OF CARBONS, Proceedings, Fourth Conference on Carbon,
Buffalo, 1960, pp. 585-591.

A consistent interpretation of the elastic properties of carbon and graphite implies that graphite adjusts to impressed stresses by a resolved relative movement of the layer planes making up the crystal structure of all carbons. It explains the following phenomena: the effect of neutron irradiation on elastic moduli; the effect of impregnation and heat-treatment on carbons; the elastic moduli and their temperature coefficients for a variety of graphites; and the elastic hysteresis and dynamic damping at low frequencies of carbons and graphites before and after heat-treatment and neutron irradiation.

963. Defense Metals Information Center,
DIFFUSION RATES AND SOLUBILITIES OF INTERSTITIALS
IN REFRACTORY METALS by W. D. Klopp and V. D. Barth,
Memorandum, No. 50, 4 April 1960, 10 pp.

Diffusion of oxygen, hydrogen, nitrogen, and carbon in tantalum and niobium at temperatures ranging from 500° to 2000° C is measured by internal friction and hardness traverses.

964. Delatte, J.,
INFLUENCE OF COBALT ON THE DIFFUSION COEFFICIENT OF CARBON AND NITROGEN IN FERRITE, Proceedings, Internal Friction of Metals, France, 1960, pp. 155-162.

The diffusion coefficient varies rather slightly and generally decreases with additions of cobalt. In the case

of nitrogen, the variation of the diffusion coefficient as a function of cobalt content shows certain irregularities.

965. De Morton, M. E.,
PRELIMINARY INTERNAL FRICTION MEASUREMENTS
IN CHROMIUM, Transactions, Metallurgical Society of
American Institute of Mining, Metallurgical, and Petro-
leum Engineers (AIME), Vol. 218, April 1960, pp. 294-299.

Low-frequency internal friction measurements on annealed chromium show a marked increase in damping below -40° C which is strongly strain amplitude dependent. An interpretation of results is presented in terms of the motion of antiferromagnetic domains assumed to exist below -40° C.

966. Dickenscheid, W. and Brauner, J.,
EFFECT OF PHOSPHORUS ON THE DAMPING AND AGING
(PROPERTIES) OF IRON-NITROGEN ALLOYS, Archiv für
das Eisenhüttenwesen, Vol. 31, 1960, pp. 531-536.

Damping measurements carried out on iron-nitrogen-phosphorus alloys containing phosphorus 0.014 percent to 0.167 percent, silicon 0.02 percent, manganese 0.04 percent to 0.08 percent, and sulfur 0.015 percent to 0.22 percent within the temperature range of 20° to 150° showed that the maximum value of damping decreases with increase in phosphorus content while the temperature of the maximum damping value increases. The residual damping value is not affected by the phosphorus content.

967. Dickson, E. W.,
THE OBSERVATION OF SHARP INTERNAL FRICTION PEAKS
IN BERYLLIUM, Philosophical Magazine, Vol. 5, Series 8,
April 1960, pp. 325-333.

Measurements were made as a function of strain and temperature with specimens of commercially pure beryllium. Very sharp internal friction peaks were observed which are similar to those reported as occurring in aluminum. The previously suggested mechanism giving rise to those maxima is discussed in terms of the evidence obtained here.

968. Druyvesteyne, M. J.,
INFLUENCE OF PLASTIC DEFORMATION AT LOW TEMPERATURE ON THE RIGIDITY OF Cu, Ag and Al, Proceedings, Internal Friction of Metals, France, 1960, pp. 93-96.

This paper analyzes the influence of the amount of plastic deformation at 78° K and the presence of dislocations on rigidity and internal friction of copper, silver, and aluminum wires. Included is a study of the restoration process from 78° to 300° K and the relationship of dislocation equilibrium to shearing stress and Burger's vector.

969. Einspruch, N. G.,
ANISOTROPY IN ULTRASONIC ATTENUATION IN SINGLE-CRYSTAL ALUMINUM, Acta Metallurgica, Vol. 8, No. 3, March 1960, p. 216.

Measurements of attenuation in high-purity aluminum single crystal are compared with the prediction of Granato and Lücke that internal friction due to dislocations should be sensitive to crystal orientation. The sequence of magnitudes of five measured attenuations and the closeness in values for the measurements of shear wave in [001] and fast shear wave in [110] agree with theory.

970. Entwistle, K. M.,
THE DAMPING CAPACITY OF METALS, Proceedings, The Physical Examination of Metals, Edward Arnold Limited, London, England, 1960, pp. 487-558.

This paper presents a comparison of resonant bar, inertia and mechanical hysteresis loop methods for measuring damping capacity, a theoretical explanation of the origins, and damping capacity measurements as used in flaw detection and other test methods.

971. Entwistle, K. M.,
ON THE MEASUREMENT OF THE ANELASTICITY OF THE VACANCY-SOLUTE ATOM INTERACTION IN TERNARY ALLOYS OF ALUMINIUM AND COPPER BASE, Proceedings, Internal Friction of Metals, France, 1960, pp. 131-137.

This paper presents a determination of relationship of damping effect to aging temperature (20° to 220° C), decay,

formation of vacancies, and anelasticity of solute atom vacancy interactions in heat-treated aluminum-copper alloy and aluminum-copper-indium alloy.

972. Entwistle, K. M.,
STUDIES OF AGING AND PRECIPITATION IN METALS
USING ANELASTIC DAMPING MEASUREMENTS, Progress
in Nondestructive Testing, Vol. 2, pp. 189-222.

The nature and origin of the anelastic damping caused by stress-induced ordering of solute atoms is discussed, and measurements of aging alloys which can be interpreted in terms of this effect are described. Important differences between the ordering process in interstitial and substitutional solid solutions arise from the need for vacant lattice sites in the migration of substitutional atoms, and the two types of solutions are discussed separately.

973. Falk, S.,
THE CLASSIFICATION OF DAMPING VIBRATION SYSTEMS
AND LIMITS ON THEIR EIGENVALUES, Ingenieur-Archiv,
Vol. 29, No. 6, 1960, pp. 436-444.

This paper presents the classification of damped vibrating systems, analyzing the limits of their eigenvalues. Problems have several degrees of freedom, representing the frequency equation in matrix form and assuming that the inertia matrix, the dissipative matrix, and the stiffness matrix are complex hermitian matrices. The domains of the eigenvalues are drawn and discussed for complex and real roots. The stability question is considered. The problem is generalized for arbitrary matrices.

974. Fast, J. D.,
INTERNAL STRESS IN METALS, Proceedings, Internal
Friction of Metals, France, 1960, pp. 9-47.

Determination of effects of thermoelastic and Snoek effect, grain boundary viscosity and electron, atom, point defect and dislocation mobility on relaxation and effect of dislocation and Bloch wall mobility on hysteresis in ferrous and nonferrous metals and alloys. Use of magneto-mechanical and electron damping measurements to determine internal stress, solubility, gas diffusion, and crystal properties.

975. Fast, J. D. and Verrijp, M. B.,
INTERNAL FRICTION OF PURE IRON AFTER LIGHT
PLASTIC DEFORMATION, Proceedings, Internal Friction
of Metals, France, 1960, pp. 97-105.

Determination of internal friction and damping effect of heat-treated iron wire as a function of deformation and measurement temperature (20° C and -170° to 70° C), deformation amplitude and time, carbon content and crystal properties.

976. Fast, J. D., Meijering, J. L., and Verrijp, M. B.,
INTERNAL FRICTION IN FERRITIC Fe-Mn-N ALLOYS,
Proceedings, Internal Friction of Metals, France, 1960,
pp. 145-147.

Analysis of the effect of location and nitrogen atoms, quantity of manganese atoms and interactivity of manganese and nitrogen atoms on variations in internal friction of nitrated and heat-treated iron-nitrogen and iron-manganese alloys.

977. Favstov, Yu. K.,
DETERMINATION OF INTERNAL FRICTION IN METALS,
Akademiya Nauk SSSR, Otdeleniye Tekhnicheskikh Nauk,
Izvestiya, Metallurgiya i Toplivo, No. 2, 1960, pp. 140-143.

The dependence between the logarithmic attenuation decrements calculated from the same experimental data at any time t , being the ratio between a and a_t , the starting and current oscillation amplitudes, is established.

978. Filmer, A. J., Rogers, D. H., and Hutchison, T. S.,
LOW TEMPERATURE INTERNAL FRICTION IN METALS
AT KILOCYCLE FREQUENCY, Progress in Refrigeration
Science and Technology, Pergamon Press, 1960, pp. 127-
131.

Study of the internal friction of cold-rolled and annealed polycrystalline aluminum at 4.2° to 273° K, and 40 kc/sec to determine its dependence on strain amplitude, temperature, and crystal size.

979. Fisher, P. A.,
MAGNESIUM ALLOYS FOR ENGINEERING USE, Proceedings, Engineering Materials and Design Conference, February 1960, pp. R1-R8.

Paper explores tensile properties, modulus of elasticity, damping capacity, resistance to fatigue, impact strength, and other mechanical characteristics of magnesium base alloys, and applications in aircraft and automobile components and industrial and consumer products.

980. Friedel, J.,
CREEP AND INTERNAL FRICTION AT HIGH TEMPERATURE, Proceedings, Internal Friction of Metals, France, 1960, pp. 83-88.

This paper presents a study of the effect of vacancy autodiffusion, dislocation structure and density, creep test temperature (300° to 600° C) and stress on internal friction and creep resistance of aluminum crystals.

981. Fujimoto, T., Shunji, T., and Inoue, Y.,
INTERNAL VISCOSITY OF POLYMER FILMS MEASURED BY FREE TORSIONAL OSCILLATION, Kogyo Kagkan Zasshi, Vol. 63, 1960, pp. 1427-1430.

The mechanical properties of films of polyvinyl chloride of mean degree of polymerization 1400, of copolymers of vinyl chloride and vinyl acetate, and of polyvinyl chloride plasticized with dioctyl phthalate, were studied in the glass-transition region by free oscillation methods. The magnitude of maximum damping and its temperature were decreased with the increase in both the load and the resistance of the suspending wire, but the damping-temperature curve obtained by applying the corrections for the effects of the load and the wire was independent of the measuring methods.

982. Galkin, A. A. and Korolyuk, A. P.,
APPARATUS FOR STUDY OF ULTRASONIC ABSORPTION BY METALS AT LOW TEMPERATURES, Pribory i Tekh. Ekspt., No. 6, 1960, pp. 99-103.

The dependence of the absorption coefficient on the magnetic field was measured by the impulse method. A

diagram and circuitry of the apparatus are given. A specially constructed cryostat and sample holder are also described.

983. Garber, R. I. and Miller, Yu. G. ,
A RAPID METHOD OF CALCULATING THE DAMPING
FACTOR FROM OSCILLOGRAMS, Industrial Laboratory,
Vol. 25, No. 10, August 1960, pp. 1291-1292 (Translation of
Zavodskaiia Laboratoriia, SSSR, Vol. 25, No. 10, October
1959, pp. 1235-1236 by Instrument Society of America,
Pittsburgh, Pennsylvania, 1959).

Not abstracted.

984. Garber, R. I. and Soloshenko, I. I. ,
THE PLASTIC DEFORMATION AND AMPLITUDE DEPEND-
ENCE OF THE DECREMENT OF ATTENUATION OF
ELASTIC OSCILLATIONS IN SUPERSTRESSED MICRO-
REGIONS, Physics of Metals and Metallography, Vol. 10,
No. 6, 1960, pp. 139-142.

From the variation in the decrement of attenuation it is demonstrated that the strain hardening of a crystal at high amplitudes does not rule out its subsequent strengthening at lower amplitudes, and vice versa. This may serve as confirmation of the proposition that at each stress there is a different selection of weak places.

985. Gent, A. N. ,
SIMPLE ROTARY DYNAMIC TESTING MACHING, British
Journal of Applied Physics, Vol. 11, No. 4, April 1960,
pp. 165-167.

A test machine is described for determining the dynamic shear properties of rubber-like materials. It imposes a simple shear deformation, the direction of which is continuously rotated. The dynamic shear modulus and damping factor can be determined rapidly over a relatively wide frequency range. Measurements of a soft butyl rubber are described and compared with observations of free torsional oscillations. The test-piece is subjected to a rotating shear of constant amplitude, and hence the elasticity-stored energy is held.

986. Gerson, R.,
DEPENDENCE OF MECHANICAL Q AND YOUNG'S MODULUS
OF FERROELECTRIC CERAMICS ON STRESS AMPLITUDE,
Journal of Acoustical Society of America, Vol. 32, No. 10,
October 1960, pp. 1297-1301.

The effects of stress amplitude on the mechanical properties of several barium-titanate and lead-titanate-zirconate compositions were studied experimentally. Data were obtained for internal friction and Young's modulus up to a stress of 4000 psi.

987. Gerstner, R.,
QUANTITATIVE MEASUREMENT OF SOUND ATTENUATION BY MEANS OF ULTRASOUND IMPULSE INSTRUMENTS, Berg-und Hüttenmannische Monaschefte, Vol. 105, No. 3-4, 1960, pp. 49-52.

This article presents a computation of attenuation from wall thickness and height of the nth echo, and investigates the effect of frequency.

988. Gibbons, T. B. and O'Hara, S.,
THE EFFECT OF INTERNAL OXIDATION ON THE DAMPING CAPACITY OF COPPER-SILICON ALLOYS, Philosophical Magazine, Vol. 5, Series 8, February 1960, pp. 140-145.

Damping capacity measurements have been carried out on copper-silicon alloy specimens before and after internal oxidation, and the results were compared with those for oxygen-free, high-conductivity copper specimens given the same treatment. High damping values have been noted for the fully internally oxidized copper-silicon material, and it is suggested that this is caused, to some extent, by the generation of relatively free dislocations around the silica particles during the growth and subsequent cooling of these inclusions.

989. Goecke, H.,
RHEOLINAR VIBRATIONS WITH PERIODICALLY VARIABLE DAMPING AND SPRING FORCES, Wissenschaftliche Zeit, Vol. 4, No. 2, 1960, pp. 135-137 (In German).

Not abstracted.

990. Goodman, L. E. and Rattayya, J. V.,
REVIEW OF PANEL FLUTTER AND EFFECTS OF AERO-
DYNAMIC NOISE. PARTS I AND II, Applied Mechanics
Reviews, Vol. 13, January-February 1960.

Part I is a brief review of the literature pertaining to the interaction between aerodynamic forces and panel motions, usually referred to as "panel flutter." Since the problem is too complex to be dealt with in its entirety, simplifying assumptions have been made in the various investigations. The literature is marked by a certain degree of controversy over the validity of these assumptions and the applicability of the results obtained. Of special interest are the two articles where structural damping has been included in the analysis. Part II reviews the literature relating to the measurement and theory of jet noise and its effect on panels and secondary structures. A total of 177 articles is listed. Of particular interest are those which discuss the importance of damping in structures exposed to jet noise environments.

991. Goto, M.,
EFFECT OF ANNEALING ON THE INTERNAL FRICTION
OF THE COLD-ROLLED ALUMINUM PLATES, Part 1,
Hiroshima University, Journal of Science, Vol. 23, Series
A, March 1960, pp. 389-393.

The resonance curve of the forced lateral vibration at 1100 cps at room temperature is used to determine the internal friction of samples annealed at 50° to 270° C after cold rolling. Internal friction is affected by annealing temperatures only to 270° C while strain amplitude affects internal friction only at annealing temperatures above this point.

992. Government Mechanical Laboratory, Japan,
EFFECT OF PLASTIC DEFORMATION ON ULTRASONIC
ATTENUATION IN METALS by A. Hikata, October 1960,
Report No. 39, 94 pp.

Stress-strain relations in aluminum, copper, aluminum alloys, and steel are determined by fatigue and creep testing at various temperatures, stresses, frequencies, and strain rates. Attenuation and its recovery mechanisms are analyzed by the Granato-Lücke's dislocation theory.

993. Grabendorfer, W.,
INSTRUMENT FOR MEASURING THE VELOCITY AND
DAMPING OF SOUND IMPULSES, Berg-und Hüttenmannische
Monatshefte, Vol. 105, No. 3-4, 1960, pp. 42-46.

Measurement of values with cast carbon steel with 0.24 percent to 0.39 percent carbon and cast alloy steel with 0.04 percent to 0.34 percent carbon, zero to 2.25 percent molybdenum, zero to 18.20 percent chromium, zero to 1.22 percent manganese, zero to 11.20 percent nickel and up to 1.34 percent silicon.

994. Granato, A. V., Lücke, K., and Stern, R. M.,
RESONANCE OF DISLOCATIONS AND ITS APPLICATION
TO MEASUREMENTS OF INTERACTIONS BETWEEN
FAULTS AND DISLOCATIONS, Frottement Intérieur Métaux,
Compt. Rend. Colloq., Saint-Germain-en-Laye, France,
1960, pp. 57-77.

Data obtained from detailed examination of lattice structures of crystals at weak amplitudes based on the Koehler vibrating-string model have led to a number of theories for the measurement of dislocations. Although the Koehler theory applies only to low frequencies, Granato and Lücke extended it to the megacycle and kilocycle ranges by using internal friction methods.

995. Grin, A. V.,
INTERNAL FRICTION AT THE GRAIN BOUNDARIES IN
ALUMINUM, Akademii Nauk, SSSR, Fizika Metallov i
Metallovedenie, Vol. 9, No. 4, April 1960, pp. 613-615
(In Russian).

The temperature dependence of internal friction was determined for three grades of aluminum, 99.994 percent aluminum representing the purest material. With increasing impurity content the magnitude of the internal-friction peak increased, its position was shifted towards higher temperature, and the activation energy for internal friction increased. The effects observed were attributed to preferential adsorption of impurities at the grain boundaries.

996. Grin, A. V. and Pavlov, V. A.,
INTERNAL FRICTION IN DEFORMED ALPHA SOLID SOLUTIONS OF ALUMINUM AND MAGNESIUM, Relaksatsion. Yavleniya v Metal. i Splavakh, Moskov. Inst. Stali, Trudy Mezhvuz. Soveshchaniyz, 1960, pp. 190-198.

The internal friction of the samples, made by alloying of aluminum with 0.05 percent, 0.5 percent, and 1 percent magnesium, was measured with a torsional pendulum at one cycle per second in a slowly heated furnace. Two peaks (A and B) were observed on these curves. The A peak (180° to 230°) is caused by diffusion of magnesium in deformed alloys and the B (240°) by recrystallization. The position of B maximum remained unchanged with increased magnesium content, but its width decreases. During relaxation, a third peak appeared at 300°.

997. Gurov, K. P. and Borovskii, I. B.,
A THEORY OF DILUTE SOLID SOLUTIONS, Akademii Nauk, SSSR, Fizika Metallov i Metallovedenie, Vol. 10, No. 4, 1960, pp. 513-519.

A theory postulating formation of atomic aggregates around an impurity is shown to explain the following properties of alpha-iron-tungsten solid solutions: (1) a maximum in the concentration dependence of Young's modulus at 0.06 atomic percent tungsten, (2) a maximum in the temperature dependence of the internal-friction coefficient, (3) a minimum in the concentration dependence of the electrical resistivity, (4) a minimum in the concentration dependence of the effective number of electrons.

998. Haas, C.,
THE DIFFUSION OF OXYGEN IN SILICON AND GERMANIUM, Journal of Physical Chemistry Solids, Vol. 15, No. 1-2, August 1960, pp. 108-111.

Using a simple model for the structure of oxygen in silicone and germanium crystals and making the assumption that internal friction and diffusion are both due to the same relaxation phenomenon, the diffusion coefficient of oxygen is calculated from experimental data on internal friction.

999. Heller, W. and Nacken, M.,
STUDY OF DEFORMATION AGING IN MILD UNALLOYED
STEELS BY TENSILE STRENGTH AND DAMPING MEASURE-
MENTS, Archiv für das Eisenhüttenwesen, Vol. 31, December
1960, pp. 723-730.

Annealed and tensile deformed wire specimens of electro-
steel, basic Bessemer steel and air-refined special steel
containing 0.009 percent to 0.0185 percent carbon are tensile
deformed and aged at 20° to 250° C. Aging is studied by
stress-strain curves, damping measurements determining
carbon precipitation and coercive force measurements.

1000. Hempel, M.,
INVESTIGATION OF THE PHYSICAL AND METALLURGICAL
PROPERTIES DURING FATIGUE TESTS, Draht, Vol. 11,
April 1960, pp. 151-157.

This article investigates the effect of cycling on hard-
ness, yield, tensile, impact, and fatigue strengths of carbon
steel. Also discussed are changes of damping properties,
temperature, electrical conductivity, magnetic induction,
and structure with number of cycles.

1001. Hiki, Y.,
INTERNAL FRICTION OF QUARTZ, Journal of Physical
Society, Japan, April 1960, Vol. 15, No. 4, pp. 586-592.

The internal friction of transparent natural quartz was
measured at room temperature with longitudinal vibration
in kilocycle range using a composite piezoelectric oscillator.
The internal friction of specimens parallel to the Y- or Z-
axis was small and almost independent of the strain ampli-
tude of the vibration, while that of specimens with other
orientations was rather large and showed marked dependence
on the amplitude.

1002. Hoft, H.,
MEASUREMENTS OF DAMPING IN IRON, Wiss. Z.
Hochschule Elektrotech. Illmenau, Vol. 6, 1960, pp. 105-
112.

A torsion pendulum was built for studies between zero
and 850°. High-purity iron and Armco iron are investigated.

The damping maximum and dissolved carbon are shown as functions of temperature. The effect of cold working is investigated.

1003. Hogberg, H., Lovell, S. E., and Ferry, J. D.,
MECHANICAL LOSSES OF POLYSTYRENES WITH DIFFERENT MOLECULAR-WEIGHT DISTRIBUTIONS, Acta Chemica Scandinavica, Vol. 14, 1960, pp. 1424-1431.

Dynamic mechanical measurements were made on two polystyrene samples with sharp molecular weight distributions and one with a broad distribution, at temperatures and frequencies corresponding to the plateau zone where the mechanical losses pass through minimum. The losses are calculated in terms of the loss compliance, loss modulus, and loss tangent.

1004. Holwech, I.,
RECOVERY OF INTERNAL FRICTION IN ALUMINUM AFTER PLASTIC DEFORMATION, Journal of Applied Physics, Vol. 31, 1960, pp. 928-931.

The internal friction in polycrystalline superpurity aluminum was measured during and after creep under constant load by the ultrasonic pulse method. The increase in internal friction was independent of frequency in the measured range (2.5 to 12 mc/sec). The experimental results are discussed in terms of the Weertman-Salkovitz theory of low-amplitude internal friction.

1005. Ibarki, M. and Sugimoto, K.,
SOME OBSERVATIONS ON THE INTERNAL FRICTION OF DEFORMED IRON, Osaka University, Institute of Scientific and Industrial Research, Memoirs, Vol. 17, 1960, pp. 137-142.

Internal friction of both annealed and deformed iron is measured at room temperature as a function of strain amplitude in the kilocycle range. The Koster effect in iron is also examined and results show effect is similar to the strain-aging effect in both the velocity and the activation energy.

1006. Ichiyama, T.,
INTERNAL FRICTION IN NICKEL, Japan Institute of Metals, Journal, Vol. 24, March 1960, pp.191-195.

Internal friction in a high-purity nickel is measured as a function of temperature, using a torsion pendulum at a low frequency of vibration. The internal-friction curve consists of a background damping, which increases as the temperature increases, and a peak at 510° C (0.44 cps) due to grain boundary stress relaxation with an associated activation energy of 63,500 calories per mole.

1007. Ichiyama, T., Kawasaki, M., and Takashina, K.,
INTERNAL FRICTION IN MARTENSITE AND TEMPERED MARTENSITE, Japan Institute of Metals, Journal, Vol. 24, July 1960, pp. 456-460.

Internal friction in quench-hardened plain carbon steels containing 0.68 percent to 1.14 percent carbon measured by torsion pendulum at two cps. Effect of stress-induced ordering of carbon atoms, dislocation interaction, ferrite formation, and temperature on relaxation peaks.

1008. Kaddou, A. F. K. and Rosenthal, P. C.,
CORRELATION BETWEEN INTERNAL FRICTION AND TEMPER BRITTLENESS IN STEEL, Transactions, American Society for Metals, Vol. 52, 1960, pp. 116-126.

Internal-friction measurements were made with a torsional pendulum at a frequency of 1.5 cps from room temperature to 500° F by using plain carbon and low-alloy steels. A new theory on the basic mechanism of temper brittleness is based on a dislocation model.

1009. Kaneko, M., Hikichi, K., and Furuichi, J.,
MEASUREMENT OF VISCOELASTICITY OF COATING FILMS AND THIN FILMS, Oyo Butsuri, Vol. 29, 1960, pp. 113-116.

A simple torsional pendulum was constructed. Variation of the complex rigidity modulus of thin films of polystyrene with temperature was measured between 20° and 120° at about 0.2 cps. Two maxima in tangent δ were found, one at 116° and a small secondary hump at 56°.

1010. Kataev, G. I. and Sirota, Z. D.,
ANOMALIES OF THE ELASTICITY MODULUS AND OF
INTERNAL FRICTION IN THE Fe₃Pt ALLOY, Zhurnal
Eksperimental'noi i Teoreticheskoi Fiziki, Vol. 38, 1960,
pp. 1037-1041.

An alloy containing 58 percent by weight platinum and 42 percent iron, annealed at 1020° and quenched in H₂O, was measured. The Young's modulus E increased anomalously beyond 220°; the internal friction has a sharp maximum at the Curie point (71°).

1011. Kaufman, J. G.,
DAMPING PROPERTIES OF CLAD ALUMINUM, Product
Engineering, Vol. 31, 23 May 1960, pp. 54-55.

Although the cladding lowers tensile strength for a given section thickness, the added damping in a part also lowers stress caused by vibration. Tests on 2024-T3 clad with 5 and 10 percent pure aluminum show that damping capacity of this structural material can be increased up to 20 times.

1012. Ketova, V. P. and Pavlov, V. A.,
EFFECT OF ELASTIC OSCILLATION ON INTERNAL FRICTION IN ALUMINUM WITH 2 PER CENT MAGNESIUM ALLOY, AT LOW TEMPERATURES, Akademii Nauk, SSSR, Fizika Metallov i Metallovedenie, Vol. 10, 1960, pp. 445-452.

The effect of elastic oscillations of 10⁻⁵ order of magnitude on temperature dependence of internal friction at oscillation frequency 1500 cps and at 200° to 300° K was studied. There is a peak of internal friction near 250° K. The explanation involves crystal lattice defects of a vacancy type, pits, and the surface layer of oxide.

1013. Khodov, Z. L. and Il'chenko, V. I.,
TEMPERATURE DEPENDENCE OF YOUNG'S MODULUS AND THE DAMPING DECREMENT OF NICHROME ALLOYS WITH ADMIXTURES OF TUNGSTEN OR MOLYBDENUM, Ukrayin. fiz. Zh., Vol. 5, No. 2, 1960, pp. 235-241.

The sharp rise in the value of the decrement, observed at a definite temperature for each alloy, is probably associated with viscous slipping along the grain boundaries. The dependence of the modulus on the molybdenum or tungsten

concentration suggests that molybdenum and tungsten admixtures have a similar effect on nickel-chromium alloys, at any rate in the case of a slight admixture (up to three atomic percent).

1014. King, J. C., Wood, D. L., and Dodd, D. M.,
INFRARED AND LOW-TEMPERATURE ACOUSTIC ABSORPTION IN SYNTHETIC QUARTZ, Physical Review Letters, Vol. 4, 15 May 1960, pp. 500-501.

The defect responsible for infrared absorption at 3620cm^{-1} and for acoustic absorption at 50°K in hydrothermally-grown synthetic quartz crystals is discussed. It was found that the defect responsible for the 50°K absorption was virtually eliminated when a synthetic crystal was given a similar treatment.

1015. Kline, D. E.,
DYNAMIC MECHANICAL PROPERTIES OF EPOXY RESINS DURING POLYMERIZATION, Journal of Applied Polymer Science, Vol. 4, 1960, p. 123.

Mechanical loss and dynamic modulus as a function of temperature were determined for samples prepared from a Bisphenol A-based epoxy resin (Epon-828 of the Shell Chemical Company) with m-phenylenediamine as a catalyst, filled with fine aluminum powder or unfilled.

1016. Knorr, W. and Scholl, H.,
INVESTIGATION OF TRANSITION BEHAVIOR OF TITANIUM-MOLYBDENUM AND TITANIUM-VANADIUM ALLOYS, Zeitschrift für Metallkunde, Vol. 51, October 1960, pp. 605-612.

This article presents isothermal and nonisothermal damping measurements on heat-treated binary titanium-vanadium and titanium-molybdenum bars of varying composition at zero to 700°C , and an evaluation of phase relations from modulus of elasticity and damping capacity measurements.

1017. Kolsky, H. ,
THE MECHANICAL TESTING OF HIGH POLYMERS,
Progress in Non-Destructive Testing, Vol. 2, New York,
New York, The MacMillan Company, 1960, pp. 28-59.

Not abstracted.

1018. Kono, R. ,
TEMPERATURE DEPENDENCE OF THE DYNAMIC SHEAR
AND BULK MODULUS OF POLYMETHYL METHACRYLATE,
Kobunshi Kagaku, Vol. 17, 1960, pp. 151-153.

Velocity and attenuation of transverse and longitudinal waves in polymethyl methacrylate are measured at the frequency of 0.5 mc/sec at 30° to 180°.

1019. Kor, J. W. ,
INTERNAL FRICTION IN STEELS OF COMMERCIAL
PURITY, Proceedings, Internal Friction of Metals, France,
1960, pp. 149-154.

Internal friction as a function of nitrogen and carbon content, and grain size and measurement temperature (-20° to 60° C) in heat-treated, semi-killed, aluminum-killed, and rimmed-steel wires.

1020. Krautkopf, D. W. ,
ULTRASONIC SCATTERING AND ATTENUATION IN POLY-
CRYSTALLINE COPPER AND ALPHA-BRASS, Journal of
Acoustical Society of America, Vol. 32, 1960, pp. 824-835.

These metals were studied by ultrasonic-pulse techniques at 100 kilocycle-18 megacycle frequencies, corresponding to scatterer-circumference-to-wavelength ratios ($\pi D/\Lambda$) of 10^{-3} -1.6. Observed scattering levels were in reasonable agreement with theory except at low $\pi D/\Lambda$, where the back-scattering decreased with increasing frequency. This was ascribed to propagation phenomena associated with attenuation vibrations in lossless media.

1021. Krishtal, M. A. ,
CONCENTRATION OF VACANCIES IN IRON-CHROMIUM
ALLOYS, Physics of Metals and Metallography, Vol. 10,
No. 5, 1960, pp. 82-88.

Methods are put forward for the determination of the concentration of vacancies in the gamma state in iron and its alloys with 0.85 percent to 5.72 percent chromium. These methods, which are based on the measurement of the electrical resistivity of the alloys and of internal friction, produce comparable results. Moreover, it is shown that in alloys with an increased chromium content there is an increase in activation energy of the formation of vacancies and a reduction in their concentration.

1022. Krishtal, M. A. and Golovin, S. A. ,
INTERNAL FRICTION IN HARDENED AND ANNEALED
STEEL, Relaksatsion. Yavleniya v Metal. i Splavakh,
Moskov, Inst. Stali, Trudy Mezhvuz. Soveshchaniya, 1960,
pp. 95-100 (In Russian).

The internal friction of two steel wire specimens was studied. Internal friction was measured, and the curves of internal friction as a function of temperature were plotted for both steels. The height of the internal friction peaks observed in hardened and annealed steels are caused by the diffusion stresses in austenite. The increase of the maximum of internal friction is proportional to the increased content of residual austenite.

1023. Krivoglas, M. A. ,
A THEORY OF DAMPING OF ELASTIC VIBRATIONS IN
TWO-PHASE MIXTURES, Akademii Nauk, SSSR, Fizika
Metallov i Metallovedenie, Vol. 10, No. 4, October 1960,
pp. 497-512 (In Russian).

This article presents a theory of a mechanism of elastic vibration damping due to changes in phase equilibrium produced by the passage of an elastic wave through a two-phase mixture. Also discussed are the frequency dependences of the velocity and the absorption coefficient of acoustic waves, and the internal friction in mixtures with various types of phase transition. One-component two-phase systems and two-phase solid solutions are included.

1024. Krotz, A. S.,
MECHANICAL CHARACTERISTICS OF ELASTOMERS,
Machine Design, Vol. 32, No. 24, 24 November 1960.

The author discusses the characteristics of elastomers including hardness, temperature properties, stress limits, fatigue life, and damping properties. An extensive table of properties of ten elastomers is presented. Some of these materials have loss factors as high as 1.5.

1025. Kuharenko, P. G. and Freimann, L. S.,
AN ANALYSIS OF THE RECORDING OF DAMPING VIBRA -
TIONS, Referativnyi Zhurnal, Mekhanika, No. 10, Rev.
12751, 1960 (Kauchn. Zap. Voromezhs. Lesotekhn. In-ta,
No. 16, 1959, pp. 165-173).

Six definitions of logarithmic decrement are proposed. Results are given of the analysis of oscillograms carried out by means of some of the methods referred to. It is shown that there is but little difference in the results of the analyses made by the different methods.

1026. Kusakawa, T. and Iijima, S.,
DAMPING CAPACITY OF CAST IRON, Imono, Vol. 32,
June 1960, pp. 446-452.

This paper discusses elastic hysteresis, the Cambridge torsional damping machine, with logarithmic decrement and attenuator, and the attenuate coefficient of ultrasonic waves.

1027. Lancaster, P.,
FREE VIBRATION AND HYSTERETIC DAMPING, Royal
Aeronautical Society, Journal, Vol. 64, 1960, p. 229.

Discussion includes the solutions for the differential equation of a freely-vibrating single-degree-of-freedom system with hysteretic damping proposed by Bishop, Reid, and Myklestad. A solution with a satisfactory physical interpretation is presented, and a system containing both viscous damping and hysteretic damping is considered.

1028. Lazan, B. J.,
MATERIAL AND STRUCTURAL DAMPING FOR VIBRATION
CONTROL, Transactions, Society of Automotive Engineers,
1960, p. 68.

The increasing importance of near-resonant vibrations and the role of system damping in their control is discussed. The various component parts of system damping are classified and analyzed within the framework of:

- (1) Hysteretic damping within the structural material, and
- (2) Structural damping associated with
 - (a) Interface slip of Coulomb friction and
 - (b) Shear strain in an adhesive layer at an interface.

Each of these mechanisms is analyzed to emphasize the factors important in the utilization of damping as an engineering property.

1029. Lead Industries Association, New York,
IMPROVED SOUND BARRIERS EMPLOYING LEAD, A. I. A.,
No. 39, 1960.

In this bulletin, sound barriers employing lead are shown to compare favorably with, or exceed the specifications of, all other sound barriers except for cost. According to this article, good sound isolation is obtained from high weight, low rigidity materials. The transmission loss for solid, single partitions of several commonly used materials is compared in tables and graphs.

1030. Leak, G. M.,
APPLICATION OF INTERNAL-FRICTION MEASUREMENTS
TO THE STUDY OF GASES IN METALS, Proceedings,
Determination of Gases in Metals, Iron and Steel Institute,
London, England, 1960, pp. 270-295.

Review of the damping mechanism and methods of measuring it with the torsion pendulum. Results are discussed for nitrogen in iron, silicon-iron-nitrogen alloys and hydrogen in iron.

1031. Leak, G. M.,
INTERACTION BETWEEN NITROGEN ATOMS AND DISLOCATIONS DURING STRAIN AGING, Proceedings, Internal Friction of Metals, France, 1960, pp. 127-129.

This paper presents an analysis of the effects of adding nitrogen, water quenching, cold extrusion, and aging on the relationship of internal friction in iron wires to interaction of nitrogen interstitial atoms and dislocations.

1032. Lee, H. C.,
FORCED LATERAL VIBRATION OF A UNIFORM CANTILEVER BEAM WITH INTERNAL AND EXTERNAL DAMPING, Journal of Applied Mechanics, Vol. 27, No. 3, September 1960, pp. 551-556.

The steady-state response problem of a uniform beam with a sinusoidal shaking force at the base is studied for the case where the beam material is the general linear substance represented by a model having an additional spring element in parallel with the Maxwell elements. In the analysis, the stress-strain relationship is applied only to the longitudinal strain of the beam, leaving the shear stress-strain relation to be that of a perfectly elastic material. The exact solution with a numerical example is given for one case where the shear and rotatory inertia effects are neglected.

1033. Leibowitz, J. R.,
ULTRASONIC SHEAR WAVE ATTENUATION IN SUPERCONDUCTING TIN, University Microfilms, Ann Arbor, Michigan, Order No. 63-1040, 1960, 94 pp., Thesis.

The superconducting attenuation of transverse ultrasonic waves was studied experimentally in tin single crystals. The temperature dependence of attenuation was measured down to 1.1° K for frequencies between 10 and 50 mc/sec, as a function of propagation and polarization directions. In general, the attenuation was found to be separable into two regions, a sharply falling temperature, followed by a region of more gradual attenuation change with temperature. Observed values of total attenuation and residual attenuation were not consistent with free-electron theories, and suggested that real-metals effect play an important role in the coupling of shear waves to electrons in tin.

1034. LeRolland, P. and Plenard, E. ,
SOME APPLICATIONS OF A NEW METHOD FOR DETER-
MINING THE DAMPING CAPACITY OF SOLIDS, Mémoires
Scientifiques de la Revue de Métallurgie, Vol. 57, May
1960, pp. 371-388.

This article describes a differential method based on the principle of induced low-frequency vibrations and the use of a single pendulum apparatus. It contains a critical study and comparison of the results obtained by this and other methods on plexiglass. Also discussed are applications to the study of gray irons, and the influence of structure of graphite on damping capacity of these materials.

1035. Levitt, A. P. and Martin, A. G. ,
ULTRASONIC DETERMINATION OF ELASTIC CONSTANTS
OF METALS AT ELEVATED TEMPERATURES, Nondestructive
Testing, Vol. 18, September-October 1960, pp. 333-336.

Ultrasonic pulse-echo technique is developed for measuring tensile and shear moduli of super alloys 19-9DL and Hastelloy C, steels SAE 4140 and 4340 and titanium alloy 155 from room temperature to 1600°, 2000°, 1500°, and 1200° F, respectively.

1036. Livshits, B. G. , Avraamov, Yu. S. , Osvenskii, V. B. ,
Mezhennaya, S. O. , and Belyakov, L. N. ,
INTERNAL FRICTION OF METASTABLE SOLID SOLU-
TIONS, Relaksatsion, Yavleniya v Metal. i Splavakh, Moskov.
Inst. Stali, Trudy Mezhvuz. Soveschchaniya, 1960, pp. 126-
127.

The effect of temperature on internal friction was studied for samples of Ni₃Mn alloy of stoichiometric composition, on the same alloy containing 1.34 percent and 2.77 percent molybdenum, on Ni₃Fe alloy without molybdenum, and on E1437A alloy. Metastable peaks were observed on the curve of temperature versus internal friction at 120° and 290° (peaks A and B). There are no A and B metastable peaks in the Ni₃Fe alloy, in spite of the fact that it is also an ordered alloy. The height of the peaks increased with increased amount of molybdenum in the alloy. The absence of the peaks in the Ni₃Fe alloy only confirm the opinion that A and B peaks are related to the presence of molybdenum atoms in solid solution.

1037. Longden, E.,
THE FUTURE OF CAST IRON, Iron and Steel, Vol. 33,
May 1960, pp. 267-271.

Serviceability of the material is remarkable in its versatility, especially in regard to its various properties, including vibration absorption, intrinsic strength, structure stability, damping capacity, wear abrasion, galling, and creep and corrosion resistance.

1038. Lothe, J.,
ASPECTS OF THE THEORIES OF DISLOCATION MOBILITY
AND INTERNAL FRICTION, Physical Review, Vol. 117,
No. 3, 1960, pp. 704-708.

The theory of dislocation mobility is reconsidered, and it is concluded that the interaction between thermal waves and a moving vibrating dislocation causes a friction drag. Modifications of the Seeger-Donth theory for the Bordoni peak are suggested. When account is taken of the diffusion of kinks, general agreement with the experiment is obtained. The theory of internal friction in the microwave region is briefly reviewed and discussed.

1039. Lung, C. W.,
CHANGES IN THE INTERNAL-FRICTION PEAK OF α - IRON
DURING HOMOGENIZATION, K'io Hsueh T'ung Pao, No. 7,
1960, pp. 221-222.

Iron specimens one millimeter in diameter were heated in raw H₂ atmosphere at 720° for five hours to remove carbon; the peak of internal friction vanished. Then the specimen was placed in a vacuum quartz tube, heated additionally for 15 hours, and rapidly cooled. The vanished peak of internal friction appeared again. The disappearance of the internal-friction peak during heating from 700° to 720° cannot be attributed to the removal of carbon.

1040. Lung, C. W.,
GROWTH OF FERRITE GRAINS DURING HIGH-
TEMPERATURE ANNEALING STUDIED BY THE METHOD
OF INTERNAL FRICTION, Chin Shu Hsueh Pao, Vol. 5,
No. 1, 1960, pp. 42-47.

Growth of ferrite grains in steel containing 0.025 percent carbon was studied. Growth was caused by high temperature

($\leq 1000^\circ$) annealing. The experiments revealed the relation between growth of ferrite grains and increase of the Snoek peak during annealing. The energy of activation of growth of ferrite grains was determined.

1041. Mackinnon, L. and Taylor, M. T.,
THE POSSIBLE RELATION BETWEEN THE SHAPE OF
THE FERMI SURFACE AND THE MAGNETIC-FIELD
ROTATION DIAGRAMS OF ULTRASONIC ATTENUATION,
Proceedings, Fermi Surface International Conference,
Cooperstown, New York, 1960, pp. 251-257, 258-265.

Both theory and experiment showed anisotropy for anisotropic Fermi surfaces; the experimental results obtained for fields parallel to the sound have not been explained.

1042. Magnaflux Corporation, Chicago, Illinois,
MODERN MEASUREMENT METHODS FOR METALLURGY
by F. Foerster, 1960, Bulletin MT-7.

A new method for the determination of modulus of elasticity and damping automatically is described.

1043. Maksimyk, P. A.,
MAXIMUM INTERNAL FRICTION IN ALUMINUM-COPPER -
NICKEL ALLOYS CAUSED BY THE GRAIN BOUNDARY,
Relaksatsion. Yavleniya v Metal. i Splavakh, Moskov. Inst.
Stali, Trudy Mezhvuz. Soveshchaniya, 1960, pp. 289-294.

There is a maximum on the curves of internal friction as a function of temperature of aluminum-copper-nickel alloys, having a constant 4.0 percent copper and a zero, 0.5 percent, 1.0 percent, 1.5 percent, and 2.0 percent nickel. This maximum is caused by the viscosity on the grain boundaries. The height of this peak increases with increased nickel content in the alloy, which is evidently caused by the retarding action of nickel on aging.

1044. Maringer, R. E.,
EFFECTS OF DIRECTIONAL ORDERING ON THE DAMPING
OF ZONE-MELTED IRON, Journal of Applied Physics,
Supplement to Vol. 31, May 1960, pp. 229-230.

Damping measurements are carried out as a function of temperature and time on high-purity iron to which carbon or

nitrogen has been added. The magnetoelastic contribution to the damping is isolated. A distortion of the Snoek peak and a time dependent decrease in damping are the two principal effects.

1045. Mason, W. P.,
PHONON VISCOSITY AND ITS EFFECT ON ACOUSTIC
WAVE ATTENUATION AND DISLOCATION MOTION,
Journal of Acoustical Society of America, Vol. 32, April
1960, pp. 458-472.

Phonon viscosity and its effect on acoustic wave attenuation and dislocation motion are discussed. By using thermal and sound velocity measurements to evaluate the viscosity, it is shown that available data on the attenuation of sound in metals and nonconducting crystals are in agreement with the calculated values of dislocation damping by phonon viscosity. A direct check for both edge and screw dislocation is obtained from recent work on the velocity of dislocations in LiF.

1046. Matsuda, J.,
YOUNG'S MODULUS OF SILICATE GLASS AS A FUNCTION
OF TEMPERATURE, Review of Physical Chemistry of
Japan, Vol. 30, 1960, pp. 9-24.

Measurements of Young's modulus at 25° to 500° were made by a dynamic method on normal and annealed samples of glass containing SiO₂ 68.7 percent, Na₂O 19 percent, K₂O 1.6 percent, CaO 8.5 percent, and Al₂O₃ 1.9 percent. The internal friction, Q^{-1} , has a maximum at 160° for an annealed sample, attributable to substitutional disordering between Na⁺ and K⁺.

1047. Mayer, G. and Lecomte, M.,
INTERNAL ENERGY AND ELASTIC CONSTANTS OF SILI-
CON IRRADIATED BY FAST NEUTRONS, Journal de
Physique et le Radium, France, Vol. 21, No. 4, April 1960,
pp. 242-248 (In French).

Silicon monocrystals were pile irradiated with doses of fast neutrons. The internal energy and the elastic properties were measured at various stages of the irradiation. The influence of heat treatment on these properties was then investigated. Using the numerical values thus obtained, an attempt is made to determine the nature and number of defects induced in these crystals by fast neutrons.

1048. Mead, D. J.,
THE EFFECT OF A DAMPING COMPOUND ON JET-
EFFLUX EXCITED VIBRATIONS, Aircraft Engineering,
Vol. 32, No. 373, Part 1, March 1960, pp. 64-72; No. 374,
Part 2, April 1960, pp. 106-113.

The theory is presented of the increase in damping that can be obtained when a damping compound is added to a simple structure vibrating in a bending mode. It is shown that the maximum damping ratio is obtained when the damping compound is applied to the stringer flange over the center 40 percent of the pin-ended length of the beam. A preliminary experimental investigation is described, in which damping measurements were made on a simple structural specimen treated with Aquaplas.

1049. Meijering, J. L.,
CONSIDERATIONS OF SNOEK EFFECT IN THE CASE OF
NON-EQUIVALENT SITES FOR INTERSTITIAL ATOMS,
Proceedings, Internal Friction of Metals, France, 1960,
pp. 139-143.

This paper presents a study of the relationship of location of nitrogen atom and its free energy on Snoek damping effect in quenched and annealed iron-nitrogen, iron-manganese-nitrogen, iron-molybdenum-nitrogen, iron-chromium-nitrogen, and iron-vanadium-nitrogen alloys.

1050. Merkulov, L. G.,
ABSORPTION OF ULTRASONIC AND HYPERSONIC WAVES
IN CERTAIN CRYSTALS, Primenenie Ul'traakustiki k
Issledovan. Veshchestva, No. 11, 1960, pp. 247-252.

Measurements are made on crystalline quartz (natural and synthetic), potassium tartrate, LiF, NaCl, KCl, and KBr, over various frequency and temperature intervals in the ranges 5 to 2000 mc/sec and -195° to 350° . For all the crystals, the absorption coefficient is proportional to the square of the frequency, depends very little on the type of wave or its direction in the crystal, and is independent of temperature over a wide range.

1051. Merkulov, L. G. and Yakovlev, L. A.,
ULTRASONIC INVESTIGATIONS IN DEFORMED NaCl
CRYSTALS, Akusticheskii Zhurnal, Vol. 6, No. 2, April-
June 1960, pp. 244-251 (Soviet Physics-Acoustics, Vol. 6,
No. 2, October-December 1960, pp. 239-245, Translation).

Measurements were made to determine the absorption and velocity of ultrasonic waves in deformed sodium chloride crystals. The ultrasound method makes it possible to determine the density of dislocations and their distribution in the crystallographic planes, to study the mechanism for the multiplication of dislocations, and to distinguish old and new dislocations. The interaction of point defects with the lattice and with dislocations can be evaluated from the time variation of absorption.

1052. Miller, Y. G.,
YOUNG'S MODULUS AND THE INTERNAL FRICTION OF
AN IRON ALLOY, Trudi Institute Metallurgia Baikov, Vol.
6, 1960, p. 20.

Investigations showed that the modulus of elasticity and internal friction have the same relationship to the concentration of alloying element as do the self-diffusion coefficient and the coefficient of linear expansion.

1053. Milne, R. D.,
ON THE ESTIMATION OF STRUCTURAL DAMPING FROM
AIRCRAFT RESONANCE TESTS, Journal of Aerospace
Science, Vol. 27, No. 5, May 1960, pp. 339-343.

The inclusion of an allowance for structural damping in flutter calculations is becoming increasingly necessary. Within the framework of linearized "complex" damping, a method is proposed for estimating, from ground resonance tests on the prototype aircraft, appropriate damping coefficients for incorporation into the flutter equations. The revised flutter calculations may thus include a realistic allowance for structural damping; in particular, account may be taken of the coupling which normally exists in practice between undamped normal modes.

1054. Mišek, K.,
ORIGIN OF THE MAGNETOMECHANICAL EFFECT IN AN
ALTERNATING FIELD, Czechoslovak Journal of Physics,
Vol. B10, 1960, pp. 104-118.

The paper describes further experiments on the internal friction of nickel in an alternating magnetic field. It was found that the effect is not caused by macroscopic eddy currents but by microscopic eddy currents connected with changes in domain structure, which macroscopically have a reversible character and which appear both in the region of wall displacements and in the region of the rotation of magnetization vectors.

1055. Mitsche, R.,
ATTENUATION OF ULTRASOUND, STRUCTURE AND
DEGREE OF HOMOGENEITY OF CAST IRON AND CAST
STEEL, Berg-und Hüttenmannische Monatshefte, Vol. 105,
March-April 1960, pp. 52-60.

Present knowledge of the relation between ultrasound attenuation and microstructure is reviewed. It is concluded that at present the application of the integral measurement of the attenuation of ultrasound is neither feasible for an appraisal of the structure nor for the detection of certain defects, such as microcracks, fine pores, sponginess, etc.

1056. Mohyuddin, I. and Douglas, R. W.,
SOME OBSERVATIONS OF THE ANELASTICITY OF
GLASSES, Physics and Chemistry of Glasses, Vol. 1, No.
3, June 1960, pp. 71-86.

The damping of torsional vibrations in fibers of glass was measured in a simple apparatus over a temperature range from -100° to 450° C. The glasses investigated included binary silicate glasses containing lithium, sodium, potassium, a commercial soda-lime-silica glass and soda-lime-silica glass containing only two-percent CaO. There is a background absorption of energy which increases rapidly at higher temperatures. Superimposed on this background are two peaks. Of these peaks, the one which occurs at low temperatures is thought to be due to stress-induced diffusion of the alkali ions. The second peak is shown to be due, probably, to the stress-induced diffusion of oxygen ions.

1057. Morinaga, T., Zaima, S., and Aono, Y.,
MECHANICAL PROPERTIES OF A MINIATURE RADAR
HOUSING COMPOSED OF 5% Mg HYDROSODIUM, Imono,
Vol. 32, August 1960, pp. 547-554.

Tensile strength, elongation, Brinell hardness, shear strength and damping capacity of aluminum alloy castings for radar housings.

1058. Morse, R. W.,
THE FERMI SURFACES (FS) OF THE NOBLE METALS BY
ULTRASONICS, Proceedings, Fermi Surface International
Conference, Cooperstown, New York, 1960, pp. 214-223.

The work reported on copper, gold, and silver, indicates that the Fermi surfaces are topologically similar. As the frequency of the longitudinal wave was increased, a periodic component and a high field increase were developed in the attenuation. This high field attenuation was sensitive to the direction of hydrogen in the crystal and provided patterns with curves which could be correlated with particular orbits in the Fermi surface.

1059. Naumkina, N. I., Tartakovskii, B. D., and Efrussi, M. M.,
A TWO LAYER VIBRATION ABSORBING STRUCTURE,
Soviet Physics-Acoustics, Vol. 5, No. 4, June 1960, pp.
514-517.

The addition of a lightweight plastic foam layer between a steel bar and a vibration damping layer gave a logarithmic decrement for flexural vibration up to six times that achieved with a single damping layer of equal superficial weight. Curves are given for optimum values of layer thicknesses and weights.

1060. Niblett, D. H. and Wilks, J.,
DISLOCATION DAMPING IN METALS, Advances in Physics,
Vol. 9, January 1960, pp. 1-88.

The subject of this review is discussed under four main headings: (1) the peak at low temperatures in the internal friction versus temperature curve in cold-worked face-centered cubic metals (Bordoni peak), (2) amplitude dependent internal friction at low and medium temperatures (approximately 300° K), (3) internal friction at high

temperatures, and (4) amplitude-independent internal friction at low strain amplitudes. The measurements and the effects of such factors as strain amplitude, cold work, purity, neutron irradiation frequency, and annealing are discussed in relation to current theories.

1061. Nine, H. D.,
PHOTOSENSITIVE ULTRASONIC ATTENUATION IN CdS,
Physical Review Letters, Vol. 4, 1 April 1960, pp. 359-361.

The effect of white light radiation on ultrasonic wave propagation in CdS single crystals is discussed. In one crystal the ultrasonic attenuation at 5800A increased linearly with light intensity and in another crystal decreased linearly with light intensity. These attenuation effects differed by an order of magnitude.

1062. Northwestern University,
GRAIN-BOUNDARY COHESION AND SOLUTE-DISLOCATION INTERACTIONS DURING STRAIN AGING by J. O. Brittain, 1960, OTS, PB Report 154, 982, 25 pp.

A theory was developed for the 250° internal friction peaks observed in cold-worked and martensitic steels. This phenomenon was described as a process involving the growth and dissolution of a carbide precipitate as a consequence of an oscillating dislocation.

1063. Northwestern University,
THE INTERNAL FRICTION OF COLD-WORKED AND QUENCHED MARTENSITIC IRON AND STEEL by T. Mura, I. Tamura, and J. O. Brittain, 1960, PB 152, 691, 19 pp.

A theoretical explanation is given for the internal friction peaks that are observed at 200° to 250° for cold-worked iron and steels and for martensitic steels. The theory for the peaks is based on the addition of a term to the free energy to account for the strain energy due to the interaction of an atom and the line imperfections.

1064. Novikov, N. V.,
DETERMINING THE DISSIPATION OF ENERGY IN A MATERIAL DURING LONGITUDINAL-TORSIONAL OSCILLATIONS OF RODS, Industrial Laboratory, Vol. 25, No. 9, July 1960, pp. 1166-1170.

An experiment is described to test tubular steel specimens under longitudinal vibrations (1815 cps), or torsional vibrations (321 cps), or both types simultaneously. It was discovered that the decrement of the attenuation of torsional oscillations was higher than the decrement of attenuation of longitudinal oscillations. The superposition of torsional oscillations did not cause any change in the attenuation of longitudinal oscillations; however, the superposition of longitudinal oscillations caused an increase in the attenuation of torsional oscillations.

1065. Olsen, T.
ELECTRONIC STRUCTURE OF TIN INVESTIGATED BY ULTRASONIC ATTENUATION, Physical Review, Vol. 118, 1960, pp. 1007-1008.

The magnetic-field dependence of the ultrasonic attenuation has been measured in very pure tin single crystals. Oscillations were found that can be explained as a result of resonant conditions between the electron orbit diameter and the periodic field set up by the sound wave.

1066. Olsen, T.,
THE FERMI SURFACE IN TIN FROM ULTRASONIC ATTENUATION, Proceedings, Fermi Surface International Conference, Cooperstown, New York, 1960, pp. 237-244.

Measurements of ultrasonic attenuation as a function of magnetic field for pure tin single crystals were made at low temperatures, where the electron mean free path was comparable to the acoustical wave length. The attenuation was measured in each direction as a function of hydrogen, the sound frequency, and the direction of the field perpendicular to the propagation vector.

1067. Panovko, Y. G., Editor,
CONSTRUCTIONAL DAMPING IN RIGID JOINTS, Inst. Automation and Mech., Acad. Sci. Latvian SSR, Riga, 1960, 169 pp.

This is a collection by N. G. Kalinin, Y. A. Lebedev, V. I. Lebedev, Y. G. Panovko, and G. I. Strakhov on damping in joint configurations. Most of the material has appeared previously in individual publications.

1068. Panovko, Y. G.,
INTERNAL FRICTION IN VIBRATIONS OF ELASTIC SYSTEMS, State Edition of Physical-Mathematical Literature, Moscow, 1960, 192 pp.

This article presents a review of vibrations in discrete and continuous systems and notes several situations where damping forces are important in the analysis. The problem of determining the damping properties of materials from hysteretic loop measurements is explored, and the importance of internal friction in joints as a source of dissipation in engineering systems is discussed. Numerous joint configurations and load environments are analyzed.

1069. Pennsylvania State University, University Park, Pennsylvania,
ULTRASONIC SCATTERING AND ATTENUATION IN POLYCRYSTALLINE METALS by D. W. Krautkopf, Thesis (University Microfilms, Ann Arbor, Michigan, L. C. Card No. Mic 59-6783, 94 pp. ; Dissertation Abstracts, Vol. 20, 1960, p. 3339).)

The ultrasonic pulse technique has been employed to study acoustical scattering and attenuation in polycrystalline copper and alpha-brass. The primary objectives of this investigation were to study the scattering process by direct observation of scattered radiation, and to study the associated attenuation under conditions not previously amenable to measurement. The principal attenuation mechanisms operative at the frequencies employed are elastic hysteresis, thermoelastic relaxation due to intercrystalline thermal currents, and scattering. Comparison was made between the experimental data and the expected theoretical contribution from each of these mechanisms. The observed attenuation, over most of the range, was found to vary in the manner expected for elastic hysteresis.

1070. Piguzov, Yu. V., Alekseenko, M. F., and Fedotova, L. S., EFFECT OF ANNEALING BRITTLINESS OF HIGH-CHROMIUM STEELS ON INTERNAL FRICTION, Relaksatsion. Yavleniya v Metal. i Splavakh, Moskov. Inst. Stali, Trudy Mezhvuz. Soveshcheniya, 1960, pp. 64-83.

There is a relationship between the changes of internal friction background measured at room temperature and the annealing temperature. Depending on steel composition, the sharp decrease of resilience at 475° to 550° annealing temperature agrees with the decrease of internal friction. Correlation between the internal friction background and resilience is attributed to inclusions which block the spreading of dislocations.

1071. Piguzov, Yu. V. and Bayazitov, M. I., DETERMINATION OF THE QUENCH BRITTLINESS OF HIGH CHROMIUM STEEL BY MEANS OF INTERNAL FRICTION, Izvestiya VUZ -Chernaya Metallurgiya, March 1960, pp. 147-151.

This article presents a study of the internal friction mechanism in alloys that are heated, quenched from 930° to 1000° C, tempered at 100° to 700° C and impact bend tested. Development of quench brittleness is found to be influenced by the solubility of carbon in ferrite, and the separation of carbides from alpha-iron, which affects behavior of dislocations and quenching temperature.

1072. Piguzov, Yu. V. and Blanter, M. S., EFFECT OF QUENCHING TEMPERATURE ON THE NITROGEN PEAK OF THE INTERNAL FRICTION OF IRON, Akademii Nauk, SSSR, Fizika Metallov i Metallovedenie, Vol. 10, December 1960, pp. 931-933.

Iron wire containing impurities of 0.009 percent carbon, 0.19 percent sulfur, 0.008 percent phosphorus, 0.06 percent oxygen and $26-85 \times 10^{-4}$ percent nitrogen in solid solution are held at 720° to 1300° C for one hour and subsequently water quenched. Internal friction measurements are performed at 20° to 100° C at a vibratory frequency of 0.8 cps.

1073. Piguzov, Yu. V., Krishtal, M. A., and Golovin, S. A.,
ON THE NATURE OF THE INTERNAL FRICTION PEAK
IN HEAT-TREATED STEEL, Akademii Nauk, SSSR, Fizika
Metallov i Metallovedenie, Vol. 10, No. 2, August 1960,
pp. 285-290 (In Russian).

The effect of quenching in liquid nitrogen, quenching from sub-critical temperatures, and cold deformation on the magnitude of the internal friction peak, observed in steel at 200° C, was studied. The results, indicated that the existence of an internal friction peak in a hardened and tempered steel is associated with several relaxation processes such as diffusion of the carbon atoms in the residual austenite and movement of the carbon atoms in the regions of dislocations.

1074. Pines, B. Ya. and Den, G. S.,
INVESTIGATION OF INTERNAL FRICTION OF SINTERED
SUBSTANCES. II. TERNARY SYSTEM COPPER-NICKEL-
IRON, Akademii Nauk, SSSR, Fizika Metallov i Metallo-
vedenie, Vol. 9, No. 1, January 1960, pp. 86-90.

The temperature dependence of the internal friction of sintered copper-nickel-iron alloys was characterized by six peaks, attributed to grain-boundary diffusion. Three of these peaks were associated with the processes taking place at boundaries between similar grains, the other three being due to diffusion between grains of different phases.

1075. Pines, B. Ya. and Den, G. S.,
INVESTIGATION OF INTERNAL FRICTION OF SINTERED
SUBSTANCES. III. THE EFFECTS OF PLASTIC DEFOR-
MATION, Akademii Nauk, SSSR, Fizika Metallov i Metal-
lovedenie, Vol. 9, No. 1, January 1960, pp. 91-99.

The temperature dependence of the internal friction of sintered and plastically deformed copper, nickel, and iron specimens was studied. In addition to the normal peak associated with diffusion creep along the grain boundaries, peaks due to plastic deformation and attributed to the presence of dislocations were observed at 450° to 500° C (copper), 625° to 660° C (nickel), and 650° C (iron).

1076. Pines, B. Ya. and Den, G. S.,
INVESTIGATION OF INTERNAL FRICTION IN SINTERED
MATERIALS. V. LOW TEMPERATURE EFFECTS DUE
TO PLASTIC DEFORMATION, Akademii Nauk, SSSR,
Fizika Metallov i Metallovedenie, Vol. 10, No. 1, July 1960,
pp. 58-62.

The temperature dependence of internal friction in plastically deformed and sintered copper and nickel specimens was determined between 20° and -150° C. The curves for copper had one maximum at about -80° C, whereas the internal friction of nickel passed through two maxima, situated in the -35° to -50° C and -95° to -110° C ranges. With increasing degree of plastic deformation, the internal friction peaks were shifted towards the lower temperature region, and their height increased.

1077. Pines, B. Ya. and Teng, K. S.,
INTERNAL FRICTION IN POWDER METALLURGY PRO-
DUCTS, Relaksatsion. Yaleniya v Metal. i Splavak, Moskov.
Inst. Stali, Trudy Mezhvuz. Soveschaniyz, 1960, pp. 295-304.

The internal friction of powder metallurgy samples, made from copper, nickel, and iron powders and their mixtures, was studied. Investigated were the energy of activation, the height, and the width of peaks in samples, made of pure metals and mixtures of copper-nickel, depending on the duration of preannealing of the samples.

1078. Pines, B. Ya. and Den, G. S.,
CORRECTION OF AN ERROR, Physics of Metals and
Metallography, Vol. 9, No. 2, 1960, p. 146.

This article is concerned with the correction of an error in Vol. 8, No. 4, of Physics of Metals and Metallography. In actual fact, the values of the energy of activation determined from the "background" of the curve of internal friction are found to be considerably less than the values determined by the frequency shift of the maxima peaks of the internal friction. Consequently, the background must be interpreted as determined by a mechanism other than that controlling the peak values.

1079. Plenard, E. ,
PRACTICAL INTEREST OF THE GREAT OSCILLATION
DAMPING CAPACITY OF IRONS, Fonderie, 1960, pp. 419-
431.

This article reviews: (1) principles of the property of damping and test methods for measurement, (2) the influence of physical factors, such as temperature, frequency, amplitude of constraint, nature of vibrations and number of cycles, and (3) correlation between damping and certain mechanical properties, such as fatigue limit, shock resistance, shearing sensitivity and static strength.

1080. Quapil, G. ,
USE OF CAST IRON IN MACHINE CONSTRUCTION, Technik,
Vol. 15, November 1960, pp. 757-762.

This article explores the effect of graphite shapes on tensile strength, the damping properties of cast iron as compared with steel, the mechanical properties as a function of wall thickness, and wear resistance, machinability, and corrosion resistance of highly alloyed corrosion and heat resistant irons.

1081. Roberts, J. M. and Brown, N. ,
MICROSTRAIN IN ZINC SINGLE CRYSTALS, Transactions,
Metallurgical Society of American Institute of Mining,
Metallurgical and Petroleum Engineers (AIME), Vol. 218,
No. 3, June 1960, pp. 454-463.

The stress-strain behavior of zinc single crystals was measured over a strain range of 10^{-6} to 10^{-2} . The phenomenon of microyielding was observed in detail, and plastic strains were detected at almost zero-stress. Closed hysteresis loops were observed during loading and unloading in the strain region of about 10^{-5} . From the hysteresis a frictional stress on the dislocation of about six psi was obtained. A preliminary analysis indicates that impurities are primarily responsible for the friction.

1082. Roelig, H. and Schmahl, J.,
IMPROVEMENT OF A TEST MACHINE FOR DETERMINING
THE DAMPING PROPERTIES OF POLYMERS, Kautschuk
und Gummi, Vol. 13, 1960, pp. 221-228.

The improved Roelig machine permits dynamic testing of plastics, cords, or small cylinders or strips of vulcanizates. The dynamic modulus and loss angle can be measured over a temperature range of -60° to 200° at frequencies of 7.5 or 15 cps and under pre-stress.

1083. Rothenstein, B. and Hrinca, J.,
AMPLITUDE-DEPENDENT INTERNAL FRICTION INDUCED
BY STRESS IN Fe-Ni ALLOYS, Czechoslovak Journal of
Physics, Vol. 10, 1960, pp. 684-685.

This article presents a study of magnetomechanical phenomena on 21 percent iron -79 percent nickel layers, electrolytically deposited on a copper wire, which are subjected to tensile and torsional forces. The amplitude dependence of the internal friction during torsional oscillation is a function of the state of magnetization and can be interpreted by considering the stability of the Bloch walls.

1084. Rubber Laboratory, Mare Island Naval Shipyard, Vallejo,
California,
DEVELOPMENT OF DAMPING TREATMENTS FOR NEW
CONSTRUCTION SUBMARINES AND SURFACE SHIPS by
J. J. Eynck, November 1960, Report No. 94-24, Vol. 17.

Not abstracted.

1085. Rubber Laboratory, Mare Island Naval Shipyard, Vallejo,
California,
DEVELOPMENT OF DAMPING TREATMENTS FOR NEW
CONSTRUCTION SUBMARINES AND SURFACE SHIPS by
R. R. James, July 1960, Report No. AD-466-419, No. 1.

A new program was initiated for the development of sound damping treatments to be used in the construction of new submarines and surface vessels. It was requested that sound damping treatments be developed for: (1) webs of submarine deep-hull frames and bulkheads carrying machinery, (2) submarine machinery space and other

pressure hull plating, (3) cruiser and destroyer shell plating in way of sonar domes, (4) submarine light plating in tanks and superstructure, and (5) carrier plating.

1086. Ruzicka, J. E.,
BUILT-IN DAMPING, Space/Aeronautics, Vol. 33, April 1960, pp. 61-72.

Viscoelastic damping for static loads provides a lighter design than rigidization. The vibration amplification and resonance amplification factors for viscoelastic damping indicate its satisfactory performance. Resonant vibrations are reduced by the damping, and resonant stress is less than with low structural damping.

1087. Ryan, J. A.,
EFFECT OF DAMPING AND VIBRATION DETECTOR POSITION IN RESONANCE MEASUREMENTS, Journal of Acoustical Society of America, Vol. 32, No. 3, March 1960, pp. 408-409.

Vibrations in a finite-length thin rod at low frequencies are considered. An oscillatory character to the amplitudes of the resonance peaks is found as a function of detector position and attenuation. This phenomenon may explain the observed differences in the heights of the resonance peaks, and the recurrence of groups of large and smaller peaks in rods, plates, shells, and other vibrating systems. It may also have a considerable effect on the apparent Q (or bandwidth) of the resonance curves.

1088. Ryder, R. J. and Rindone, G. E.,
INTERNAL FRICTION OF SIMPLE ALKALI SILICATE GLASSES CONTAINING ALKALINE EARTH OXIDES. I. EXPERIMENTAL RESULTS, Journal of American Ceramic Society, Vol. 43, 1960, pp. 662-669.

Systematic addition of alkaline earth oxides to alkali silicate glasses produced significant changes in the internal friction, with the two known peaks shifting toward higher temperatures and decreasing in height, and the third peak appearing in some glasses and becoming more prominent with increasing additions. Similar peaks of internal friction were also found in some alkali-free silicate and phosphate glasses.

1089. Saada, G.,
INFLUENCE OF DEFORMATION AMPLITUDE ON INTERNAL
FRICTION OF METALLIC SAMPLES, Proceedings, Internal
Friction of Metals, France, 1960, pp. 107-110 (In French).

Study of the effect of deformation amplitude and metal purity on internal friction of rolled and heat-treated iron slabs, heat-treated OFHC copper, electrolytic copper and 99.999 percent copper components.

1090. Sakui, S. and Takei, H.,
THE RIGIDITY MODULUS AND INTERNAL FRICTION IN
QUENCH-HARDENED STEEL WIRES, Japan Institute of
Metals, Journal, Vol. 24, December 1960, pp. 810-813
(In Japanese).

The rigidity modulus, the electrical resistivity, the microhardness and the internal friction in quench-hardened steel wires containing 0.08 percent and 0.12 percent of carbon are measured as a function of reduction in area and tempering and annealing temperature at 20° to 920° C.

1091. Schenck, H., Schmidtman, E., and Kettler, H.,
INFLUENCE OF DEFORMATION AGING ON REACTIONS
IN ALTERNATING STRESSING OF STEEL, Archiv für das
Eisenhüttenwesen, Vol. 31, November 1960, pp. 659-669
(In German).

This article is concerned with reactions of alternate-stressed (under oil-cooling at 3100 rps), 190° C aged, unkilld, 0.22 percent carbon openhearth steel. Measurements were made of damping and modulus of elasticity at various numbers of load alternations. Results are interpreted in terms of dislocation theory.

1092. Schleede, H. and Schulte, F.,
PROPERTIES AND INJECTION MOLDING OF ISOTACTIC
POLYPROPYLENE, Plastverarbeiter, Vol. 11, 1960, pp.
131-136, 161-170.

The following properties of isotactic polypropylene (Hostalene PP) are given: mechanical, thermal, and electrical, the temperature dependence of the ball-pressure hardness, the dynamic elasticity modulus, the mechanical

loss factor, the impact and impact notch strength, the tensile and tearing strength, and the electrical loss factor at 10^6 , 10^4 , and 800 cps.

1093. Scholl, H. and Knorr, W.,
SOME PECULIARITIES OF THE TEMPERATURE DEPENDENCE IN DAMPING UNALLOYED TITANIUM, Technische Mitteilungen Krupp, Vol. 18, December 1960, pp. 115-118 (In German).

Forged titanium rods are annealed at 50° to 850° C to obtain 1700 to 10,000 micron grain size and subsequently are subjected to bending oscillations at frequencies of 800 to 6220 Hz and temperatures from 20° to 600° C. Damping is then measured as a function of temperature and amount of plastic deformation.

1094. Seeger, A., Schiller, P., and Kronmuller, H.,
OBSERVATIONS OF INTERSTITIAL ATOMS IN F. C. C. METALS, Philosophical Magazine, Vol. 5, Series 8, 1960, pp. 853-857.

Interstitial atoms in face-centered cubic metals are thought to exist in the form of interstitial pairs with tetragonal symmetry, and relaxation effects due to rotation of the pairs should occur. Internal friction and magnetic susceptibility measurements on drawn nickel wire were made and are interpreted in terms of interstitial pair rotation.

1095. Seraphim, D. P.,
ANELASTIC MEASUREMENTS OF ATOMIC MOBILITY IN BODY-CENTERED CUBIC Li-Mg SOLID SOLUTIONS, Transactions, American Institute of Mining, Metallurgical, and Petroleum Engineers (AIME), Vol. 218, 1960, p. 485.

Single crystals of body-centered cubic lithium-magnesium solid solutions were grown and their internal friction measured as a function of temperature. A peak of the Zener type was found in the damping spectrum.

1096. Sethna, P. R.,
STEADY STATE UNDAMPED VIBRATIONS OF A CLASS OF
NONLINEAR DISCRETE SYSTEMS, Journal of Applied
Mechanics, Vol. 1, March 1960, pp. 187-195.

Assuming that the potential energy of the system is of a special type (sum of a quadratic and a biquadratic form of the general coordinates) the equation of motion is obtained in the Lagrangian form. He introduces the principal coordinates corresponding to the linear part, the method being restricted to vibrations in the neighborhood of free linear vibrations of the system, and uses a perturbation scheme to obtain the solution approximately. Results of the first (nonlinear) approximation are discussed for some simpler cases, concerning problems of two and three degrees of freedom. The interesting results are given by diagrams and checked with those obtained from an analog computer with good correspondence.

1097. Shapoval, B. I.,
RESONANCE METHOD TO DETERMINE INTERNAL FRICTION OF METALS, Issledovaniya po Zharoproch. Splavam, Akad. Nauk SSSR, Inst. Met. im. A. A. Baikova, Vol. 6, 1960, pp. 206-210.

Electric apparatus indicated continuous change with specimen temperature of vibration amplitude at resonance under constant exciting force, by converting capacitance changes between fixed and moving plates into a voltage. Preliminary data for Armco iron during the $\alpha \rightarrow \gamma$ transformation show the method permits studies during polymorphic changes.

1098. Shaskol'skaya, M. P. and Vekilov, Yu. Kh.,
THE EFFECT OF ULTRAVIOLET AND X-RAY IRRADIATION ON THE INTERNAL FRICTION OF SILVER CHLORIDE, Vol. 2, No. 6, June 1960, pp. 1107-1110 (In Russian).

The internal friction, Q^{-1} , of both plastically deformed and annealed silver chloride decreased, when this substance was subjected to ultraviolet and/or X-ray irradiation. In the former case Q^{-1} decreased exponentially with the exposure time. Both types of irradiation increased the tensile strength of silver chloride. It was inferred that internal friction is caused by movement of dislocations.

1099. Shmatov, V. T.,
A THEORY (RELATING) INTERNAL FRICTION IN SUBSTITUTIONAL SOLID SOLUTIONS TO RELAXATION OF THE SHORT-RANGE ORDER, Akademii Nauk, SSSR, Fizika Metallov i Metallovedenie, Vol. 10, No. 1, July 1960, pp. 14-19 (In Russian).

Based on postulates of LeClaire and Lomer (*Acta Metallurgica*, Vol. 2, 1954, p. 718), a theory is developed in which the characteristic peak of internal friction in solid solutions is explained in terms of relaxation of the short-range order. Formulae for the degree of relaxation of elastic moduli and for the relaxation time are derived and compared with the experimental data on internal friction in silver-zinc and copper-zinc alloys.

1100. Shuvalov, L. A. and Likhacheva, Yu. S.,
DECAY OF OSCILLATION FROM A PIEZOVIBRATOR MADE OF FERROELECTRIC SINGLE CRYSTALS, Invest. Akad. Nauk SSSR, Ser. Fiz., Vol. 24, 1960, pp. 1216-1224.

Anomalies in the damping of mechanical and acoustical oscillations were investigated on Seignette salt, normal and irradiated with X-rays, and on triglycine sulfate. The logarithmic decrement of damping δ is large in Seignette cut at 45 degrees, and it has a sharp maximum in the Curie point for field strength $E = 0$. δ is smaller in the Y cuts of triglycine sulfate than in X 45 degree cuts of Seignette salt.

1101. Shyne, J. C. and Sinnott, M. J.,
THE STRESS-INDUCED ORDERING INTERNAL FRICTION OF IRON-RICH ALLOYS OF IRON AND ALUMINUM, Transactions, Metallurgical Society of American Institute of Mining, Metallurgical, and Petroleum Engineers (AIME), Vol. 218, October 1960, pp. 861-865.

Low-frequency mechanical damping measurements of internal friction were conducted for iron-aluminum alloys. Also investigated were the influence of the atomic ordering of the system on the stress-induced ordering internal friction, and the effect of magnetoelastic damping.

1102. Siol, M. and Mandler, R.,
METHOD FOR MECHANICAL DAMPING INVESTIGATIONS
COVERING A WIDE TEMPERATURE RANGE, Archiv für
das Eisenhüttenwesen, Vol. 31, July 1960, pp. 423-426 (In
German).

A highly sensitive torsion pendulum with optical recording which allows damping measurements up to the vicinity of the specimen melting point is described. Damping measurements are made for cold-worked alpha-iron to illustrate the usefulness of the method.

1103. Sokurskii, Yu. N. and Bobkov, Yu. V.,
AN INVESTIGATION OF THE INCREASE OF INTERNAL
FRICTION IN SPECIMENS OF POLYCRYSTALLINE
URANIUM DURING CHANGES OF TEMPERATURE, Atomnaya
Energiya, Vol. 8, 1960, p. 348.

Increased internal friction in uranium specimens heated at various rates was measured by observing the damping of torsional vibrations. The rate of increase of internal friction of the specimens gradually decreased with time and the internal friction reached a limiting value, the magnitude of which was approximately proportional to the rate of heating the specimen. The increase in internal friction arises from internal stresses caused by anisotropy of thermal expansion of the individual grains.

1104. Sokurskii, Yu. N. and Bobkov, Yu. V.,
INVESTIGATION OF INCREASE OF INTERNAL FRICTION
WITH TEMPERATURE CHANGES IN POLYCRYSTALLINE
URANIUM SPECIMENS, Kernenergie, Vol. 3, October-
November 1960, pp. 1067-1071 (In German).

Change of internal friction with temperature (20° to 290° C) is measured in terms of damping of torsion oscillations of specimens, which are quenched from the gamma phase and annealed and recrystallized in the alpha and gamma field.

1105. Sokurskii, Yu. N. and Bobkov, Yu. V.,
THE INCREASE OF INTERNAL FRICTION IN URANIUM
THROUGH THE PROCESS OF ITS TEMPERATURE CHANGE,
Atomnaya Energiya, Vol. 9, November 1960, pp. 392-398
(In Russian).

Internal friction in uranium is investigated at -120° to 20° C disclosing its dependence upon rate of temperature change, initial thermal condition, and vibrational frequency and amplitude.

1106. Soloshenko, I. I.,
RELATION BETWEEN THE DECREMENT OF DAMPING
AND THE TOTAL NUMBER OF CYCLES IN FATIGUE TESTS,
Fiz. Tverdogo Tela, Vol. 2, 1960, pp. 1864-1868.

Rock salt crystals were subjected to fatigue tests to destruction, and the decrements of damping were determined at different stages of the test. The plot of damping against the total number of cycles established the following stages in the fatigue: strengthening of the material, supply of energy with no change in the decrement value, appearance of fissure nuclei, development of the fissures, and failure.

1107. Sorokin, E. S.,
THE THEORY OF INTERNAL FRICTION IN THE VIBRA-
TION OF ELASTIC SYSTEM, Moskva, Gosudarstvennoe
Izdatel stvo Literaturny po Stroitelstvu, Arkhitekture i
Stroitelnyam Materialam, 1960, 131 pp. (In Russian).

Internal friction in solids are treated from the standpoint of an engineer who is concerned with design and construction of any kind. Chapter II contains a review of the phenomenological theories of internal friction in solids. In chapter III more details are given using models with springs and dashpots. In chapter IV the differential equations including internal friction are formulated and solved for a number of special problems (mainly free and forced vibrations of beams and plates).

1108. Southgate, P. D.,
INTERNAL FRICTION IN GERMANIUM AND SILICON. I.
ELECTRON AND IMPURITY RELAXATION, Proceedings,
Physical Society, London, Vol. 76, Part 3, 1 September
1960, pp. 385-397.

The internal friction of single-crystal silicon and germanium at 100 kc/sec showed a relation peak near 0.56 percent of the melting temperature. The peak was electronic in origin and the relaxation time was the carrier lifetime. In silicon crystals containing oxygen, having a [111] vibration axis, an internal-friction peak appeared at 1030° C (100 kc/sec). The peak was not present if the silicon was oxygen-free or had a [100] axis, and could be attributed to the movement of dissolved oxygen. The activation energy was 2.55 electron volts. The peak height varied, but in most crystals grown from silica crucibles the maximum logarithmic decrement was of the order 3×10^{-4} . In germanium, a small peak appeared in some specimens at 770° C (100 kc/sec). No reduction of its height was observed on annealing, and its shape was consistent with that of impurity relaxation.

1109. Southgate, P. D.,
INTERNAL FRICTION IN GERMANIUM AND SILICON. II.
OXYGEN MOVEMENT AND DISLOCATION DAMPING,
Proceedings, Physical Society, Great Britain, Vol. 76,
Part 3, 1 September 1960, pp. 398-408.

Measurements of the magnitude of electronic and oxygen impurity relaxation peaks in single-crystal silicon yielded values for the extrinsic carrier lifetime and the relative oxygen concentration, respectively. Dislocation relaxation produced a rise in internal friction at elevated temperatures, an activation energy of 1.1 electron volt in germanium and 1.5 electron volt in silicon being associated with the rise. In silicon and germanium specimens which were plastically deformed by about two percent, the process became dominant above 0.6 of the melting temperature. Undistorted ("as-grown") specimens showed a rise at higher temperatures, which varied in magnitude between specimens and could be due to the same process as that in deformed specimens.

1110. Southgate, P. D.,
MECHANICAL DAMPING OF GERMANIUM AND SILICON
CONTAINING IMPURITY OXYGEN, Solid State Phys. Elec-
tronics and Telecommun., Vol. 1, 1960, pp. 240-250.

Measurement of the variation of mechanical damping of single crystals of germanium and silicon at 100 kc/sec over the range 100° to 1300° C is discussed. Two peaks occur in the damping versus temperature curves of the specimens measured: the low-temperature peak appears in both germanium and silicon at about two-thirds of the melting point, i. e., 410° C and 660° C respectively, and the high-temperature peak in silicon appears at 1025° C.

1111. Southampton University, Department of Aeronautics and
Astronautics,
THE DAMPING OF ALUMINUM HONEYCOMB SANDWICH
BEAMS by D. J. Mead and G. R. Froud, July 1960, Report
No. 144.

The various sources of damping in a transversely vibrating plate of honeycomb construction are considered, and an expression is derived for the total damping ratio of an unjointed honeycomb sandwich beam. It is shown that the energy dissipation by reason of bending strain in the adhesive layer is of major importance.

1112. Southampton University, Department of Aeronautics and
Astronautics,
INTERFACE DAMPING AT RIVETED JOINTS by D. J.
Mead and D. C. G. Eaton, August 1960, Report No. 153,
Part 1 (June 1963, Report No. 241, Part 2, 53 pp.).

A theoretical examination is made of the potential structural damping increments that could be obtained by the insertion of a linear viscoelastic interfacial layer between the plates of riveted joints. To check the theory, experiments were carried out on a simple lap joint with a viscoelastic interfacial layer. The complex shear modulus of polyvinyl acetate was measured for a range of frequencies and temperatures. Experiments on singly riveted lap joints indicated that a considerable damping increment could be obtained by the addition of the damping layer.

1113. Spacek, L.,
THE INTERNAL FRICTION OF LONGITUDINAL OSCILLATIONS IN FERROMAGNETIC MATERIALS, Czechoslovak Journal of Physics, Vol. 10B, No. 6, 1960, pp. 439-451.

The theory of a new magnetomechanical phenomenon in an alternating field is discussed. The functional dependence of the internal friction peak on the frequency of the mechanical oscillations is also calculated. Agreement of theory with experiment is satisfactory.

1114. Spacek, L.,
THE INTERNAL FRICTION OF TORSIONAL OSCILLATIONS IN FERROMAGNETIC MATERIALS, Czechoslovak Journal of Physics, Vol. 10, No. 12, 1960, pp. 902-916.

Deals with the internal friction of torsional oscillations of ferromagnetic materials in a static and an alternating magnetic field. The calculation differs considerably from the case of longitudinal oscillations. In an alternating magnetic field the internal friction of torsional oscillations has a sharp maximum at $H = 0.64H_s$ where H_s is the saturated value of the field for which magnetoelastic effects disappear.

1115. Srinivasan, P.,
A METHOD OF ESTIMATING THE ENVIRONMENTAL DAMPING COEFFICIENT OF A ROTATING DISC, Journal of Aerospace Science, Vol. 27, No. 4, 1960, pp. 312-314.

The effect of environmental friction on the stationary motion of a whirling unbalanced shaft is investigated. The author derives equations which can be used to determine the environmental damping coefficient.

1116. Stager, H. and Meister, R.,
MATERIAL TESTING BY MEANS OF ULTRASOUND, Berg- und Hüttenmännische Monatshefte, Vol. 105, No. 3-4, 1960, pp. 60-74 (In German).

Ultrasonic testing of the shape of graphite, structure, elasticity and shear moduli, Poisson ratio and compressibility of cast iron, carbon steel, aluminum, magnesium, copper, and nickel alloys.

1117. Stanford, E. G. and Fearon, J. H.,
STUDIES OF AGING AND PRECIPITATION IN METALS
USING ANELASTIC DAMPING MEASUREMENTS, Progress
in Nondestructive Testing, Vol. 2, 1960, pp. 191-221.

Measurements of anelastic damping reveal details of changes accompanying aging and precipitation in metastable alloys. Nature and origin of anelastic damping are discussed.

1118. Stanley, J. T.,
INTERNAL FRICTION AND DIFFUSION OF IRON-VANADIUM
ALLOYS, Dissertation Abstracts, Vol. 20, 1960, pp. 3253-
3254, Thesis (University Microfilms, L. C. Card No. Mic
60-236, 81 pp.).

Radioactive tracer diffusion coefficients for both iron and vanadium atoms were measured in the body-centered cubic solid solution of iron-18 percent vanadium. The tracer diffusion coefficients for both components were found to obey Arrhenius equations in the temperature range from 1140° to 1460° K. The relaxation time of the Zener relaxation which occurs in this alloy was also measured at various temperatures. The relaxation time did not obey an Arrhenius equation, but it was found that the relaxation time data could be fitted quite well by two Arrhenius equations which intersect at 782° K. Although the data were not complete, it was shown that reasonable assumptions about the relation of relaxation time to diffusion coefficients leads to the conclusion that the diffusion coefficients in this alloy are diminished by a factor of almost 100 as a result of the ferromagnetic ordering.

1119. Starodubtsev, S. V., Khiznichenko, L. P., and Domoryad,
I. A.,
VARIATION OF THE ELASTIC CONSTANTS OF QUARTZ
FILAMENTS CAUSED BY Co^{60} γ -RAYS, Doklady Akademii
Nauk SSSR, Vol. 132, No. 4, 1 June 1960, pp. 803-805.

Fused-quartz (silica) filaments (diameter 80-150 μ) were tested by the torsional-oscillation method in a special apparatus (described in some detail), ensuring a high accuracy. It was found that a gamma-ray dose of 8×10^8 roentgens increases the modulus of elasticity of fused quartz by 0.16 ± 0.02 percent, the error being due to the factors of geometrical deformation.

1120. Starodubov, K. F. and Sazonova, A. A.,
EFFECT OF ANNEALING TEMPERATURE AND TEMPERA-
TURE OF ISOTHERMAL TREATMENT, DONE AFTER
HARDENING, ON THE EXTINCTION OF VIBRATIONS IN
SILICON SPRING STEEL, Relaksatsion. Yavleniya v Metal.
i Splavakh, Moskov. Inst. Stali, Trudy Mezhvuz.
Soveshchaniya, 1960, pp. 58-63.

The optimum conditions of thermal treatment, which produce in a given steel the maximum value of vibrational cyclic viscosity and minimum dampening of vibrations, were determined.

1121. Stern, D.,
A SIMPLIFIED PROCEDURE FOR FINDING CRITICAL
DAMPING RATIOS OF FLAT PLATES AND PANELS,
Machine Design, Vol. 32, No. 3, 7 July 1960, pp. 136-138.

This article presents a simple procedure that can be used in place of a standard vibration test to determine the natural frequencies and damping ratios for flat plates and panels with about the same degree of accuracy.

1122. Strakna, R. E.,
LOW-TEMPERATURE ULTRASONIC ABSORPTION IN
FAST-NEUTRON IRRADIATED FUSED SILICA, Disserta-
tion Abstracts, Vol. 21, 1961, pp. 1980-1981, Thesis (Uni-
versity Microfilms, L. C. Card No. Mic 60-5256, 102 pp.).

Ultrasonic attenuation measurements have been made in normal and fast neutron irradiated fused silica from 7.1 to 50 mc/sec and from 1.5° to 200° K. The purpose of this research was to obtain information about the mechanism of the low temperature attenuation as related to the structure of glass and the manner in which it changes with fast neutron irradiation.

1123. Thompson, D. O. and Paré, V. K.,
EFFECT OF FAST-NEUTRON BOMBARDMENT AT VARIOUS
TEMPERATURES UPON THE YOUNG'S MODULUS AND
INTERNAL FRICTION OF COPPER, Journal of Applied
Physics, Vol. 31, 1960, pp. 528-535.

Studies have been made of the variations of internal friction and elastic modulus during irradiation of pure

copper crystals at a number of temperatures in the range 90° to 300° K. The results are interpreted in terms of pinning of dislocation lines by radiation defects migrating from their points of origin.

1124. Thompson, J. E.,
BEAM METHOD FOR THE MEASUREMENT OF INTERNAL FRICTION, Journal of Scientific Instruments, Vol. 37, No. 6, June 1960, pp. 208-210.

The oscillatory motion of a swinging beam used to measure the internal friction of a silicon-iron strip has been found to be complicated, and to consist of a small amplitude, higher frequency oscillation superimposed on the main oscillation, so that difficulty arises in obtaining a unique value for the logarithmic decrement of the strip oscillation.

1125. Trapp, W. J. and Lazan, B. J.,
MATERIAL PROPERTIES THAT AFFECT ACOUSTICAL FATIGUE LIFE, AND THE ROLE OF DAMPING, American Society for Testing Materials Special Technical Publication, No. 284, 1960.

The causes and nature of acoustical fatigue are discussed and recent experiences reviewed. The dynamic response of a structure exposed to an acoustical environment is discussed to indicate the four material and configuration properties which govern fatigue life. The role and importance of each of these properties, particularly structural damping, is appraised. The mechanisms involved in both inherent structural damping and in various types of surface layer additions are analyzed and their potential damping contributions are compared.

1126. Treitel, S.,
THERMAL ATTENUATION OF NONLINEAR STRESS WAVES, Journal of Applied Physics, Vol. 31, No. 2, February 1960, pp. 391-395.

The work of Knopoff and MacDonald on the attenuation of nonlinear stress waves in solids was extended to include thermal losses. The damping of a nonlinear stress wave is completely describable in terms of two attenuation coefficients, a "mechanical" coefficient α_1 , and a "thermal"

coefficient, α_2 . The latter is probably small compared to the other, but much high-precision experimental work is required to settle this point definitely.

1127. Troshchenko, V. T.,
ON THE PROBLEM OF INTERNAL FRICTION IN A
MATERIAL, Fiz. tverdogo Tela, SSSR, Vol. 2, No. 6,
1960, pp. 1060-1069.

A physical basis is sought for the empirical equations for elastic hysteresis put forward by Davidenkov assuming that the internal friction is due to microenergy produced per deformation cycle, and this agrees with the empirical rule. It is shown that the dissipated energy depends on the detailed structure of the sample, on its dimensions, and the form of the stressed state. Expressions for the relative cycle viscosity are derived for several stressed states, and these agree with experimentation.

1128. Turner, T. J. and Williams, G. P., Jr.,
STRESS INDUCING ORDERING IN GOLD-SILVER ALLOYS,
Acta Metallurgica, Vol. 8, December 1960, pp. 891-892.

An inverted torsion pendulum and an elastic after-effect apparatus are used for relaxation measurement of the order of 1 second and 1000 seconds, respectively, on 42 percent to 68 percent silver-gold specimens in vacuum at 200° to 550° C to determine atomic and grain size and valency effects on stress-induced ordering. Ordering theories are reviewed, with an effective size resulting from compressibility difference being suggested as the most important criterion for stress-induced ordering.

1129. Ungar, E. E.,
DAMPING TAPES FOR VIBRATION CONTROL, Product Engineering, Vol. 31, 25 January 1960, pp. 57-62.

Damping materials used on steel and aluminum plates reduce fatigue failure and keep resonance energy low.

1130. United States Department of Commerce, Office of Technical Services,
INTERNAL FRICTION OF IRON-ALUMINUM ALLOYS DUE TO SOLUTE ATOM PAIRS. THEORY OF THE EFFECT
by G. Biorci, A. Ferro, and G. Montalenti, 1960, PB Report 147, 501, 43 pp.

The internal friction due to directional short-range order in iron-aluminum alloys was studied. At a frequency of about one cycle the effect appears at about 510° with a relaxation time corresponding to a process of substitutional diffusion. The intensity of the effect increases rapidly for concentrations above 10 percent, and then drops to low values in the region of Fe_3Al , where the order occurs. The curve of the intensity of the effect as a function of concentration is, with fairly good agreement, proportional to the number of solute-aluminum pairs, as deduced from X-ray results of Bradley and Jay.

1131. United States Government Research Report,
MECHANICAL PROPERTIES OF SELECTED ALLOYS AT ELEVATED TEMPERATURES: II. DESIGN CRITERIA OF SILICON CARBIDE by H. A. Pearl, J. M. Nowak, and H. G. Deban, 1960, P. B. Report 161723, Vol. 34, No. 177.

A study was made of nondestructively testing silicon carbide by density uniformity, dynamic modulus by sonic technique, X-ray diffraction under transverse load, and electrical resistivity, and internal friction.

1132. Usova, L. F.,
OXYGEN EFFECT ON PROPERTIES OF LOW-CARBON STEEL BY MEASURING THE INTERNAL FRICTION,
Relaksatsion. Yavleniya v Metal. i Splavakh, Moskov. Inst. Stali, Trudy Mezhvuz. Soveshchaniya, 1960, pp. 138-145.

The measurements were taken at various temperatures after subjecting the sample to hardening from 870° , with subsequent exposure for zero, 3 to 4, 5, 10, and 15 minutes. At an increased oxygen content a peak at 300° appears on the curves of internal friction. A part of the oxygen, present in the steel, forms a solid solution with alpha-iron.

1133. Utah University, Salt Lake City,
HIGH PRESSURE PHYSICS by P. Gibbs, G. S. Baker, K. L. DeVries, J. R. Galli, M. R. Jones, and J. L. Seely, September 1960, Contract AF33 (616)-5016 ARL-TR-60-330, 46 pp.

A torsional pendulum for measuring internal friction inside the pressure vessel was constructed and instrumented. Damping measurements on approximately 0.06-inch-diameter wire specimens can be made over a strain amplitude range of $\epsilon = 10^{-6}$ to 10^{-4} . Provision is made for an internal furnace heating the specimen over a wide temperature range.

1134. Van Bueren, H. G.,
IMPERFECTIONS IN CRYSTALS, Internal Friction in Metals, Amsterdam, North-Holland Publ. Co., 1960, Chapter XVII (New York, New York, Interscience Publ. Inc., 1960).

Mechanisms of internal friction are discussed first. These include relaxation spectrum, relaxation and anelasticity, mechanical hysteresis, damped resonance, and viscous damping. The second part of the chapter is concerned with observations of internal friction, including experimental techniques, dislocation damping, internal friction not exclusively associated with dislocation motion, internal friction related to the presence of foreign solute atoms in the metal, thermal, magnetic, and electronic damping. Finally a table which is a survey of internal friction in metals is given. A fairly extensive bibliography concludes the chapter.

1135. Vasil'eva, A. P. and Favstov, Yu. K.,
EFFECT OF ELECTROLYTIC COATING ON VIBRATION DAMPING, Vestnik Mashinostroyeniya, Vol. 40, No. 12, 1960, pp. 18-21.

Coatings of chromium, lead, and cadmium of different thicknesses were electrolytically deposited, either as one layer or a sum of many. Both damping decrement and the coefficient of damping decrease with a larger vibration amplitude, become larger in the presence of coatings, and monotonally increase with their thickness until a maximum is reached, after which additional thickness has no effect.

1136. Vedeneeva, M. A. and Tomashov, N. D.,
DETERMINATION OF INTERCRYSTALLINE CORROSION
OF THE CHROMIUM AUSTENITE STEELS BY MEASURING
INTERNAL FRICTION, Mezhkristal. Korroziya i Korroziya
Metal. v Napryazhen. Sostoyanii, Vsesoyuz. Sovet Nauch. -
Tekh. Obschestv, 1960, pp. 152-161.

The internal friction, the frequency of natural oscillation, and the electrical resistance are the quantitative characteristics of an intercrystalline corrosion. The change of internal friction is more sensitive than the change of electrical resistance and the natural rate of oscillation.

1137. Vekilov, Yu. K.,
EFFECT OF PLASTIC DEFORMATION ON INTERNAL
FRICTION AND SHEAR MODULUS OF SILVER CHLORIDE,
Izvest. Vysshikh Ucheb. Zavedenii, Chernaya Met., No. 5,
1960, pp. 76-80.

The effect of plastic deformation produced by a tensile load on internal friction in the low-frequency range, was from a silver chloride single crystal. The increase in internal friction as a result of plastic deformation was attributed to an increase in dislocation d.

1138. Verma, G. S.,
SECOND DISLOCATION RELAXATION PEAK IN ALUMINUM
AT LOW TEMPERATURES, Proceedings, Physical Society,
London, Vol. 76, Part 3, September 1960, pp. 412-414.

The frequency-temperature dependence of the second relaxation peak in aluminum was measured and used to estimate an activation energy. This activation energy is used to calculate the Peierls stress.

1139. Verma, G. S. and Joshi, S. K.,
POSSIBILITY OF MOLECULAR RESONANCE ACOUSTIC
ABSORPTION IN SOLID CYCLOHEXANE, Proceedings,
Physical Society, London, Vol. 75, 1960, pp. 935-937.

In molecular crystals resonance phenomena resulting in anomalously high acoustic absorption can occur whenever lattice and internal molecular vibration frequencies overlap. It is pointed out that there is possibility of such a resonance absorption in solid cyclohexane.

1140. Vick, G. L. and Hollander, L. E., Jr.,
ULTRASONIC MEASUREMENT OF THE ELASTIC MODULI
OF RUTILE, Journal of Acoustical Society of America, Vol.
32, 1960, pp. 947-949.

Four of the elastic moduli of rutile were determined by measuring the velocity of one-megacycle waves. Attenuation was greater in reduced than in fully oxidized rutile and was considerably greater in the alpha than in the c crystallographic direction.

1141. Vittoz, B., Martinet, B., and Secretan, B.,
DYNAMIC BEHAVIOR OF A STANDARD LINEAR SOLID,
Proceedings, Internal Friction of Metals, France, 1960,
pp. 79-82.

The propagation of longitudinal waves has been studied in a rod, on the basis of the model of a standard linear solid, that is, a linear relation between stress, strain and their time derivatives. Derivation of internal friction coefficients is also included.

1142. Wagner, K.,
USE OF CAST IRON IN THE MANUFACTURE OF VEHICLES,
Industrie-Anzeiger, Vol. 82, May 1960, pp. 600-604 (In
German).

This article presents chemical analysis and strength properties of the most common cast iron alloys, and explores the influence of wall thickness on microstructure and strength behavior, wear resistance, damping capacity, notch sensitivity, fatigue resistance, corrosion resistance, heat and sealing resistance, compression strength, hardenability, weldability, surface treatment, machinability, and special cast iron qualities.

1143. Wang, Y. N. and Chu, C. C.,
THE BEHAVIOR OF INTERNAL FRICTION ASSOCIATED
WITH THE PROCESS OF MARTENSITE-TYPE TRANS-
FORMATION, Scientia Sinica, Vol. 9, No. 2, February
1960, pp. 197-212.

Iron-manganese alloys containing 12.8 and 17.5 percent by weight manganese were investigated in a torsion-pendulum system oscillating at 1.4 cps. It was found that

the internal-friction peaks observed on heating and cooling were associated with the $\gamma \rightarrow \alpha$ and $\alpha \rightarrow \gamma$ transformations. The height of the peaks was proportional to the amount of transformation per cycle and, when the oscillation frequency, the heating (or cooling rate), and the stress were kept constant, the peak should have corresponded to the curve of the initial rate of martensite transformation.

1144. Watertown Arsenal Laboratories, Massachusetts, ULTRASONIC ATTENUATION AND PHYSICAL PROPERTIES OF METALS by J. W. Orner, Monograph Series, November 1960, 13 pp.

Progress is reported in the investigation of ultrasonic attenuation or rate of energy absorption in a solid material. As the mechanism of attenuation is becoming better understood, a very valuable nondestructive testing tool is being made available for the determination of physical properties of metals.

1145. Whitworth, R. W., EFFECTS OF VIBRATION ON THE INTERNAL FRICTION OF SODIUM CHLORIDE, Philosophical Magazine, [8], Vol. 5, 1960, pp. 425-440.

The internal friction of single crystals of NaCl, vibrated at 90 kc/sec, was very low ($\approx 10^{-5}$) in specimens annealed at 650°. In crystals plastically deformed and annealed at 100° to 200°, vibration at high strain amplitude caused an increase in friction without an increase in the number of dislocations. Freshly deformed crystals decreased in internal friction during vibration because the dislocations moved such distances as to become trapped.

1146. Wintergerst, S., DYNAMIC BEHAVIOR OF RIGID POLYVINYL CHLORIDE (PVC), Kunststoffe, Vol. 50, 1960, pp. 277-280.

Creep strength on rigid polyvinyl chloride rods was determined by Wohler curves by rotary flexing tests from -30° to 50°. The internal damping of the plastic material was determined by utilizing the temperature increase within the rods caused by repeated flexing.

1147. Wolf, J. D.,
INTERNAL FRICTION SPECTRUM OF ZONE-REFINED
IRON, Dissertation Abstracts, Vol. 21, 1960, p. 164 (Uni-
versity Microfilms, L. C. Card No. Mic 60-2180, 117 pp.

The internal friction spectrum of high-purity (zone-refined) iron is compared with that obtained for high-purity, iron-boron alloys, and for the commercial iron used as a starting material for zone-refining. Several unexpected phenomena were observed, including an amplitude dependence found in the high-purity iron and the iron-boron alloys, as well as a relatively rapid aging effect at room temperature and below. A theoretical treatment is presented for an internal friction peak arising from dislocation pinning by solute atmospheres.

1148. Wright Air Development Center, Wright-Patterson Air Force Base, Ohio,
AN INVESTIGATION OF LONGITUDINAL SHEAR DISTRIBUTION AND DAMPING IN A VISCOELASTIC ADHESIVE LAP JOINT by C. P. Avery, November 1960, Report No. TR 60-687.

Damping in a viscoelastic adhesive of a simple lap joint is analyzed. Expressions are developed for shear distribution and damping in the adhesive when the lap is sheared by a low frequency sinusoidal force. Calculations are made illustrating the variation in damping and shear distribution as a function of the dimensions and material properties of the lap components. Experiments were performed which confirm the theory.

1149. Wright Air Development Center, Wright-Patterson Air Force Base, Ohio,
STEADY STATE DAMPED VIBRATIONS AND STABILITY OF A CLASS OF NONLINEAR DISCRETE SYSTEMS by S. T. Chow and P. R. Sethna, March 1960, Report No. TR 59-543.

A class of nonlinear discrete systems with an arbitrary number of degrees of freedom is studied for their steady state vibrations. The coordinates are first transformed to the principal coordinates corresponding to the linear part of the system. An iteration scheme is used to obtain the desired solutions.

1150. Wright Air Development Center, Wright-Patterson Air Force Base, Ohio,
DAMPING OF RECTANGULAR PLATE VIBRATIONS by
T. S. Lundgren, C. C. Chang, and Y. C. Wang, March
1960, Report No. TR 59-544.

In Part A, an analysis is made of the effect of an impact-type damping mechanism on a vibrating square plate. The force which the damping mechanism exerts on the plate is idealized as a series of impulses acting at the center of the plate. It is found that the device analyzed does not make a very effective damper. In Part B, an analysis is made of the effect of a damping device on the vibrations of a rectangular plate. The damper considered is a free piston in a closed cylinder which is attached to the center of the plate. When the leakage through the gap between the piston and the cylinder is small, the piston is caused to oscillate on the "spring" of air in the cylinder. It is found that this device can effectively damp out the resonant mode of the plate vibration.

1151. Wright Air Development Center, Wright-Patterson Air Force Base, Ohio,
STEADY STATE RESPONSE OF BEAMS WITH TRANSLATIONAL AND ROTATIONAL DAMPING MOTIONS AT THE SUPPORTS by T. J. Mentel and C. C. Fu, May 1960, Report No. TR 60-60, 46 pp.

Two methods of analysis are presented for the steady state response of beams with translational and rotational damping motions at the supports. The first of these methods uses a continuous model and the second uses a discrete (three-degree-of-freedom) model. Both cases are characterized by nonlinear equations and approximate solutions. Numerical results are presented giving comparisons and optimum damping configurations.

1152. Wright Air Development Center, Wright-Patterson Air Force Base, Ohio,
ROLE OF STRUCTURAL DAMPING IN ACOUSTICAL FATIGUE by W. J. Trapp and B. J. Lazan, January 1960, Report No. TR 59-304.

Techniques proposed to reduce or eliminate materials fatigue damage due to high level noise fields of propulsion

systems and aerodynamically induced pressure fluctuations are discussed. The mechanisms, the significant parameters involved, and the response of materials and structures are analyzed. The activities undertaken and notions on the solution of the problem by employing certain damping concepts are presented.

1153. Wright Air Development Division, Wright-Patterson Air Force Base, Ohio,
PARTITIONING AND MICRODISTRIBUTION OF INTERSTITIAL ALLOYING IN TITANIUM by I. B. Cadoff and J. Winter, September 1960, Report No. TR 60-443.

The partitioning or segregation of excess interstitial solutes at the grain boundaries in alpha phase and beta phase, titanium alloys, was investigated. Internal friction spectra of dilute alloys of titanium with oxygen, nitrogen, and carbon were obtained. From these spectra, the activation energy for grain boundary stress relaxation, the net interaction energy of a solute atom with a grain boundary, and the excess solute concentration were calculated.

1154. Wright Air Development Division, Wright-Patterson Air Force Base, Ohio,
RHEOLOGICAL PROPERTIES OF ADHESIVE CONSIDERED FOR INTERFACE DAMPING by J. S. Whittier, June 1960, Report No. TR 60-280.

Machines for testing soft adhesives under static compression and shear, and under dynamic shear, are described. Static creep data in compression and shear are reported for Minnesota Mining and Manufacturing Company's 3M tape number 466. At a given compressive load this material deforms, after sufficient time has elapsed, to an "equilibrium" thickness. Dynamic shear data for 3M tape number 466 are reported for frequencies from 0.1 to 120 cps and for shear strain amplitudes from zero to unity and greater. Stress history and fatigue effects are also mentioned. This material is found to dissipate large amounts of specific damping energy when undergoing safe dynamic shear strains. Spot checks on the dynamic shear properties of three other materials at 11.5 cps are also presented.

1155. Yamamoto, T. and Nagashima, T.,
CHANGES OF INTERNAL FRICTION AND SHEAR MODULUS
DUE TO MAGNETIC ANNEALING IN Ni-Co ALLOYS,
Electrotechnical Laboratory Bulletin, Vol. 24, April 1960,
pp. 272-280 (In Japanese).

Thermal variations of internal friction and shear modulus were measured on friction and shear modulus was measured on pure nickel, several nickel-cobalt alloys, and a 68 percent nickel-iron alloy by the torsion-pendulum method. Variations are considered attributable to domain fixing as a result of atomic diffusion of quench-frozen excess imperfections.

1156. Zaidelman, R. L.,
ON A METHOD OF HANDLING THE RESULTS OF LOGARITHMIC DECREMENT MEASUREMENT, Indust. Lab.,
Vol. 25, No. 10, August 1960, pp. 1288-1291.

Paper presents a somewhat disconnected discussion of the relationship between amplitude, logarithmic decrement and number of cycles in a free damped vibration. In particular, an expression is obtained for computing the absolute error in the measurement of logarithmic decrement from an oscillogram record in terms of the number of cycles spanned by the record, and the logarithmic decrement itself.