

## I. Abstract

The purpose of this project is to study and apply advanced electronic technology to the development of integrated circuit, multiplexed telemetry systems for bio-medical applications. These systems should be implantable and be capable of telemetering a wide range of physiological signals. Three to ten channels of signals will be transmitted simultaneously.

Several multiplexing telemetering systems have been studied. A scheme has been developed which minimizes power drain, uses simple circuitry, and is applicable to hybrid integrated circuit construction. Multiplexing and de-multiplexing circuitry for a three-channel system have been constructed and bench tested.

A study was made of oscillators for the RF carrier of this multiplexing system including crystal controlled types. It was found that crystal controlled FM oscillators do not offer a wide enough information bandwidth for this multiplexing system unless elaborate and extensive circuitry is used. Since extensive circuitry is difficult to fabricate in hybrid integrated circuit form, these crystal controlled FM oscillators are not applicable to this project. A single transistor, non crystal-controlled, oscillator frequency modulated by varacaps and an amplitude-modulated crystal controlled oscillator offer simple circuitry and sufficient bandwidth. These two types will be evaluated and compared further.

Possible power supply methods for the transmitter were studied. The results indicate that nickel-cadmium rechargeable batteries, charged by an external RF source will be the most desirable method. An RF induction charging system was built and in bench tests was used to charge a nickel-cadmium battery pack of the capacity required for the transmitter circuitry.

## II. Progress Made from March to September, 1966

A time-division PAM-FM multiplexing system has been selected for development because of circuit simplicity and minimum power requirements. The individual channels are sampled in sequence in the transmitter and the amplitude samples are transmitted in sequence over the RF carrier. The receiver de-multiplexing circuitry, in synchronism with the transmitter circuitry, separates the samples to their respective channels for recording.

### A. Transmitter Circuitry

A three channel system is being built to evaluate the design. The block diagram for the transmitter is given in figure 1. After the design is proven, the system will be extended to a larger number of channels, the number being determined by the requirements of the application of the particular system.

The sampling gates are driven by a ring counter. These gates are operated by switching on and off the power supply to differential amplifiers in each channel. Figure 2 gives the circuit diagram for a single stage of

the ring counter. Note that the circuit uses only transistors and resistors. Also, since the circuit is operated in either saturation or cutoff, allowable component tolerances can easily be plus 100% or minus 50% of their nominal value. These design criteria were set up so that the circuit could be easily reduced to hybrid integrated circuit form.

The ring counter uses direct coupled logic to control the sequence in the switching on and off of stages around the ring. At any given time only one stage in the ring is turned on. The clock pulse shifts the "on" condition around the ring, and the individual stages are on in sequence.

To understand the operation of the ring counter, consider the memory unit of the individual stage as given in figure 3. This unit is bistable and the ring counter consists of these bistable units coupled in a closed ring. Suppose stage number 3 is on. Transistor  $Q_3$  in stage 4 acts as an and gate to the inputs of stage 3 being on and the arrival of a clock pulse, and turns stage 4 on when these conditions occur together. Transistor  $Q_4$  functions as a single input and gate and turns off its stage when the following stage turns on. Thus the clock pulse has effected the shifting of the "on" condition from stage 3 to stage 4.

$Q_5$  senses current in the stage and turns on the external load.

Resistor,  $R_1$ , bypasses the effect of leakage currents in  $Q_1$ ,  $Q_2$ , and  $Q_3$ .

The remaining resistors are for current limiting.

The clock used to drive the ring counter is an astable multivibrator.

Should the ring counter not function, another circuit will sense this and

reset the ring counter. This automatic reset feature is necessary so the ring counter will start properly when the power supply is turned on as well as correcting any malfunction during operation. A breadboarded version of the ring counter is under evaluation and has given reliable operation.

#### B. Receiver De-Multiplexing Circuitry

A de-multiplexing gate has been developed. This gate samples the composite PAM waveform during the time allotted for the individual channel. It charges a capacitor which holds its charge, within one percent, until the next sample for the channel arrives. This action, in effect, stretches the sample pulse; and by putting more energy into a following low-pass filter, provides amplification. The circuit for this gate is given in figure 4.

The differential comparator (Fairchild  $\mu$ A 710) compares the input to the voltage on the capacitor during the channel's sample period, and adjusts the capacitor's voltage accordingly. The circuit tested was able to faithfully reproduce the input for signals of  $\pm 6$  volts and up to one-half of the sampling frequency.

The de-multiplexing gates are driven by a ring counter similar to that in the transmitter. The clock is an astable multivibrator, synchronized by pulses obtained each time the composite waveform changes channel. The sync pulses are obtained by differentiating the composite PAM signal and passing the pulses thus obtained through a full-wave rectifier. The ring

counter is reset each time the frame sync pulse occurs. These synchronizing actions keep the de-multiplexing gates in synchronism with the multiplexing gates.

### C. Frequency-Modulated Oscillators

A study of frequency-modulated oscillators has been made to evaluate types with possible application to this system. Since a stable carrier frequency is highly desirable, crystal-controlled oscillators were studied. It is possible to vary the frequency of a crystal oscillator by varying the external capacitance presented to the crystal. The results of studying several circuits of this type showed that in order to obtain deviations of 0.01%, very critical adjustments were necessary. Also, bandwidths obtained were too small for the multi-channel system.

Phase modulation of a crystal oscillator was also studied. This method would require too extensive circuitry for the proposed integrated circuit construction. Another possibility investigated was the use of a phase-locked loop in the transmitter to stabilize the carrier frequency. This method hasn't shown promise since it is difficult to obtain sufficient isolation between the reference oscillator and the voltage controlled oscillator. There are also problems in obtaining sufficient information bandwidth.

In the course of these investigations it was noted that, for the deviation ratios necessary for the required bandwidth for the multi-channel

system, the FM improvement over AM was very small or non-existent. For this reason, and for the carrier stability offered by a crystal-controlled oscillator, an amplitude-modulated crystal-controlled oscillator was built and tested. This PAM-AM system gave good results and had more than adequate bandwidth.

Non-crystal-controlled transistorized oscillators, frequency-modulated by varacaps, were also constructed and tested. The PAM-FM circuits so tested gave good results with the exception that the frequency of oscillation was influenced by such factors as power supply variations and by the proximity of external objects. It remains to test these frequency varying effects for this circuit in integrated circuit packaging. Proximity effects should be minimized by the miniature packaging and a power amplifier stage following the oscillator.

The crystal-controlled PAM-AM circuit and the non-crystal-controlled PAM-FM circuit will be further evaluated and compared on the basis of performance and ease of construction.

An M. S. thesis resulted from this study of oscillators and modulation.<sup>1</sup>

#### D. Power Supply

It is planned that the power supply will be rechargeable nickel-cadmium batteries. The recharging will be performed by an RF field coupling to an implanted pickup and a charging-control circuit.

Rechargeable batteries were studied and charge-discharge curves were obtained experimentally for continuous cycling over a period of

several weeks for a pair of batteries.

Methods of charging were studied. It is desirable to charge the batteries to full capacity in as short a time as possible. By combining constant voltage and constant current charging, the charging time necessary was reduced from the manufacturer's recommended 14 hours to 8 hours or less.

RF powering was studied and the necessary coupling coils were constructed and tested. The charging circuit, including pickup coil and constant voltage plus constant current source, was built and used to successfully charge a 6 volt, 150 ma. hr. nickel-cadmium battery pack in an 8 hour period. The dimensions of the present pickup coil are too large for an implanted unit so that further work is necessary in this area.

Exploratory investigations were also made on the possibility of using a biological battery. Platinum-black and silver-chloride electrodes were used as anodes while zinc, steel, and aluminum were used as cathodes. Ringer's solution was used as the electrolyte. The results indicated that the maximum power density available is 200 microwatts per square centimeter for the experimental setups investigated.

This study on power supply methods results in an M. S. thesis.<sup>2</sup>

### III. Current Projects

#### A. Signal Conditioners

Development is being carried out on preamplifiers for electrical signal channels for EMG, EKG, and EEG. Resistance controlled oscillators

are being studied for use in the temperature (thermistor pickup) channels and for the channels using strain gage sensors.

B. Construction Facilities

Equipment is being set up for construction of the transmitter in hybrid integrated circuit form. During June to August, around 36,000 dollars worth of equipment was purchased from NASA and other funds for the construction and testing of the multiple-channel system.

The transmitter circuitry will be fabricated on ceramic substrates. Conductive patterns will be silk-screened onto the ceramic and then fired into the ceramic. The components will be bonded onto these patterns. Chip resistors and transistors will make up about 3/4 of the total components in the transmitter. Some monolithic integrated circuits will also be used.

A silk-screen outfit has been procured and will be put into operation in the next few weeks. This will be used to lay down conductive pads and interconnecting patterns onto the ceramic substrates. It can also be used to deposit thick film materials for resistances and possibly capacitances. The deposited materials will be fired into the ceramic using one of our tube furnaces.

An older model Kulicke and Soffa (K and S) wire bonder has been modified and will be used to bond the transistor and resistor chips to the substrate patterns. Connections will be made to the chips using a K and S



ultrasonic wire bonder and 1 mil gold or aluminum wire. A K and S probing system has been obtained for making DC measurements on the chips and circuits during the fabrication process.

The bonding and probing machines are on hand and will be installed in our clean room area very soon.

By using these fabrication techniques in the construction of the transmitter, the size of a three-channel unit, excluding power supply, will be about 1 inch square by 1/4 to 1/2 inch thick. Adding 6 more channels will add about 1/4 inch to the thickness.

#### IV. Estimated Schedule

During October the fabrication facilities will be put into operation. Construction of some of the transmitter circuitry will be under way. A breadboard of a three channel system should be completed and tested in November. By the end of the year a three channel transmitter should be ready for implanted evaluation.

Following the evaluation of this system, the design will be extended to seven channels. Also refinements will be added to the receiver circuitry to compensate for changes in the transmitter due to variations in its power supply.

References

1. Stevens, Grady, An Examination of Transistor F-M Transmitters Suitable for Multiplex Bio-Telemetry, M. S. Thesis, Case Institute of Technology, November 1966.
2. Noel, Bruce, Power Supply Problems in a Biomedical Telemetry System, M. S. Thesis, Case Institute of Technology, November 1966.

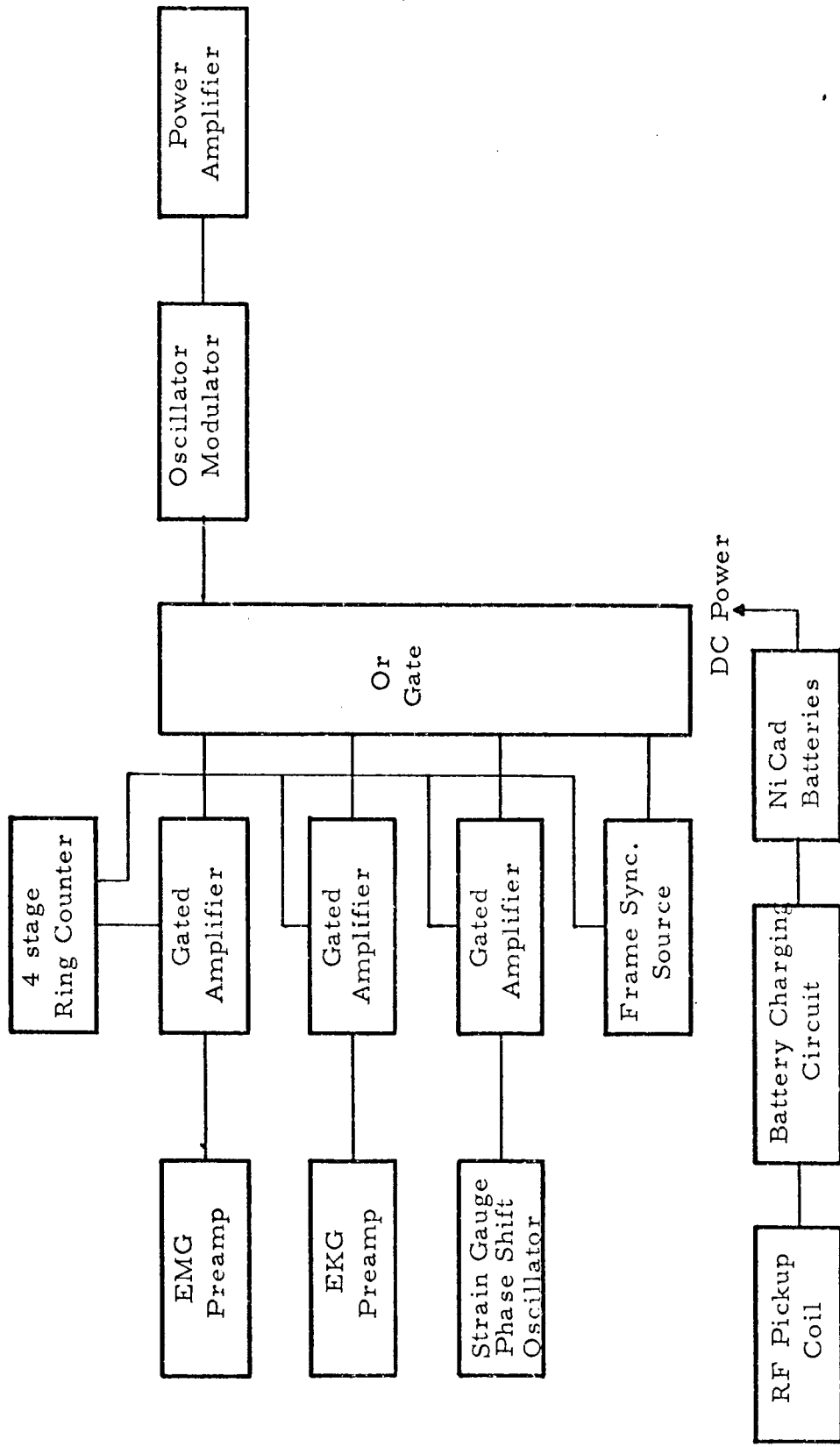

Figure 1. Block diagram for three channel PAM-FM transmitter.

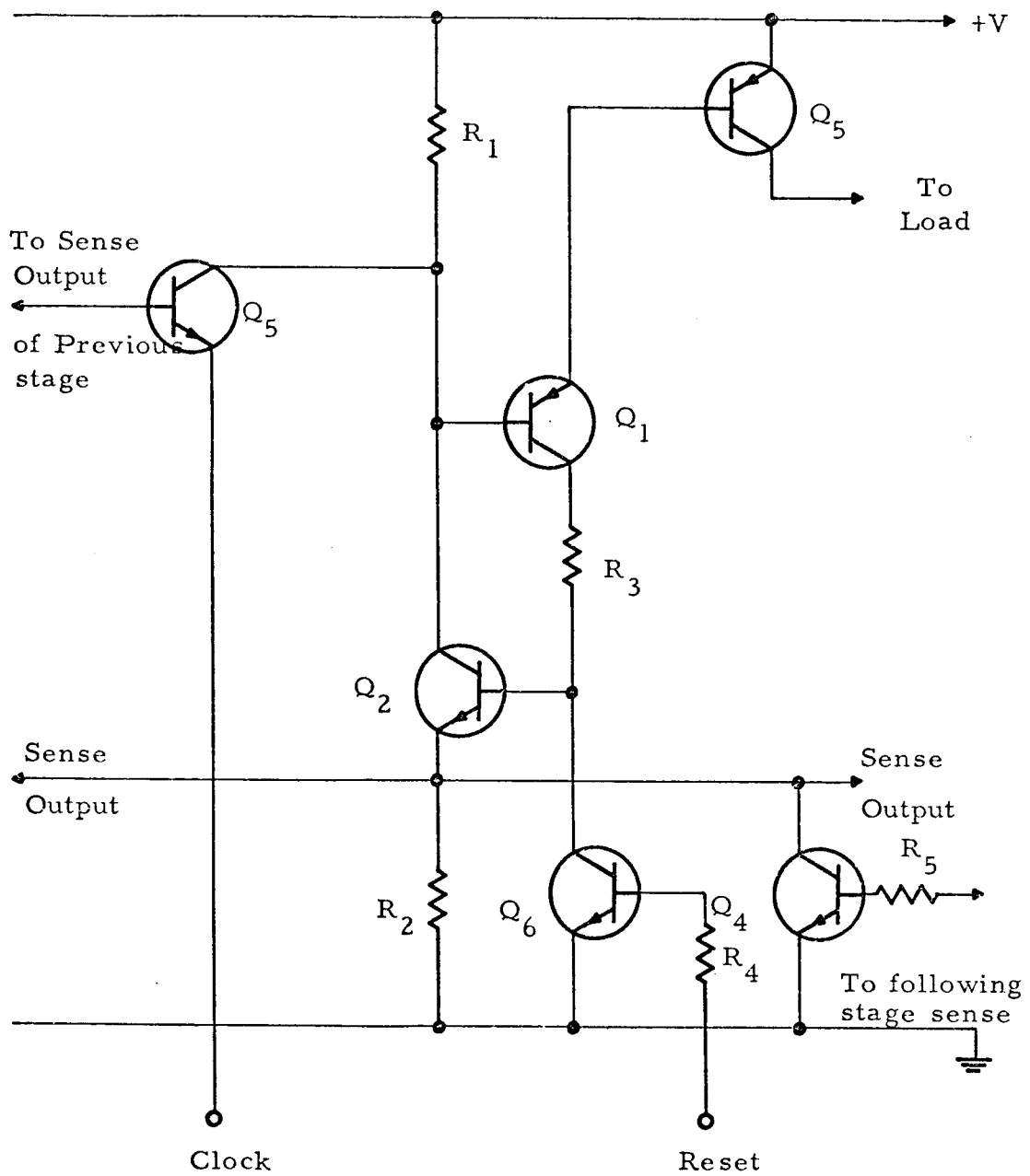

Figure 2. Ring Counter Stage

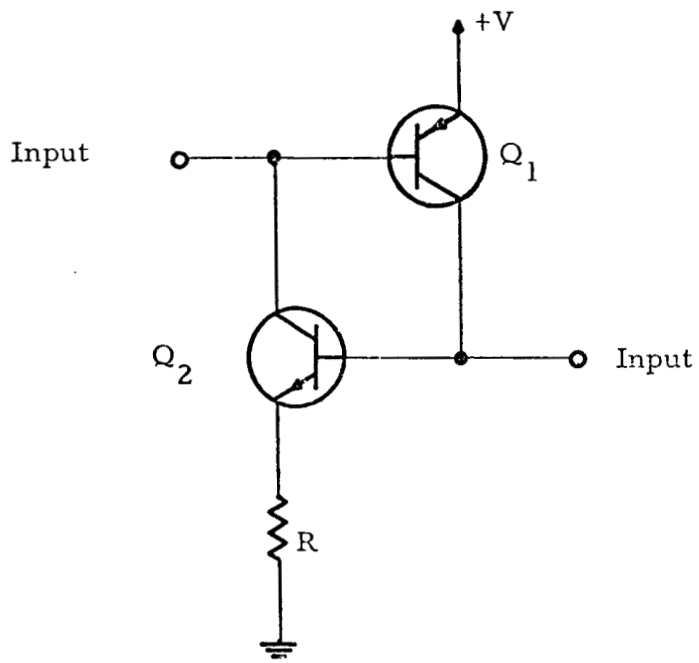

Figure 3. Memory Unit in Ring Counter Stage

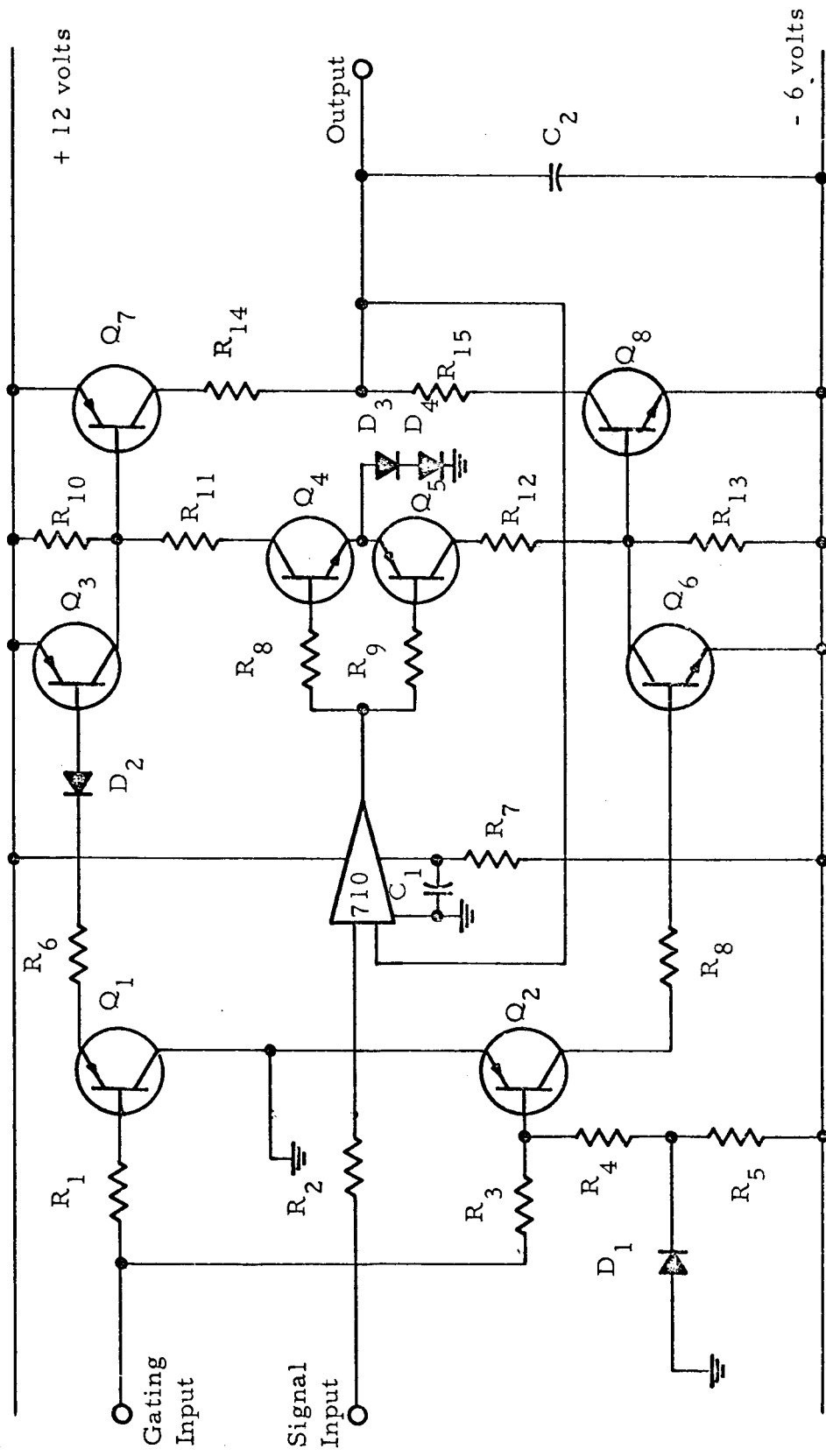

Figure 4. Sample and Hold Circuit

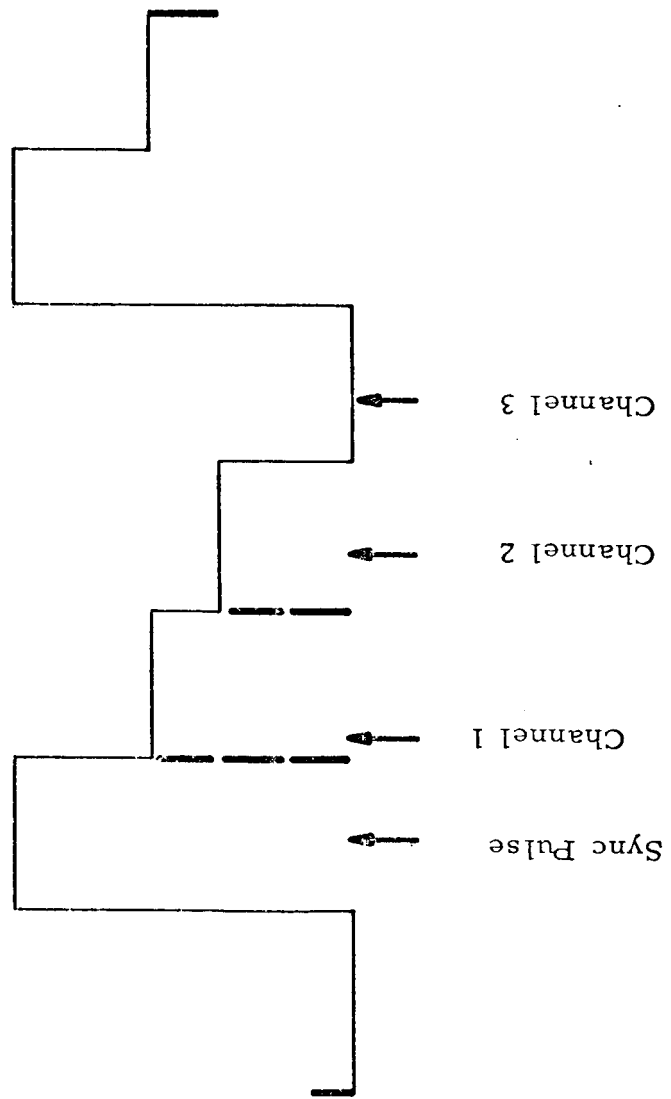

Figure 5. Typical Waveform for a PAM Three Channel Time-Shared System

POWER SUPPLY PROBLEMS IN A  
BIOMEDICAL TELEMETRY SYSTEM

Bruce W. Noel  
November 1966

Case Institute of Technology

ABSTRACT

Exploratory experiments on galvanic cells for application to body powering are described. Power densities as high as  $3 \text{ mw/cm}^2$  were obtained from these cells. The results are in general agreement with published data. Experiments with various electrode pairs in an electrolyte showed that the open-circuit terminal voltages were sensitive to changes in oxygen concentration in the electrolytes. Possible biomedical applications are suggested for this phenomenon.

Evaluation tests on nickel-cadmium batteries indicate that the batteries will perform at least as well as claimed by the manufacturer. Voltage regulation of these batteries during discharge is good over a relatively small segment of the discharge characteristic.

A power supply system for an implantable biomedical telemetry system was designed. The system couples externally-generated r-f power to an implant battery-charging circuit by induction. It is shown that the charging circuit is capable of recharging nickel-cadmium batteries in as little as one-half the time required for constant-current charging alone.



AN EXAMINATION OF TRANSISTOR F-M  
TRANSMITTERS SUITABLE FOR MULTIPLEX  
BIO-TELEMETRY

Grady H. Stevens  
November 1966

Case Institute of Technology

ABSTRACT

Microminiature telemetry transmitters have been developed in the past which use tunnel diodes to produce high frequency oscillations. These devices have inherent power limitations which restrict the transmission range to a few feet. This study is an examination of transistor circuitry which might possibly alleviate this problem, while retaining the low power level and wideband FM characteristics. These new circuits will be used on the multiple channel integrated circuit telemetry system.

Three circuits are considered. The first circuit introduced is a single transistor circuit which is capable of direct frequency modulation. The two remaining circuits possess a crystal controlled carrier. As compared with tunnel diode oscillators, only the first circuit promises superior performance at low power levels. The two other circuits have superior performance at much higher power levels.

An analysis of the first circuit, the direct frequency modulated transmitter, is presented. The result includes a derivation of the tuning characteristic, the deviation sensitivity, and the effects of square law distortion.

The two remaining circuits consist of an indirect frequency modulated transmitter and a phase-locked frequency modulated transmitter. A brief treatment of the indirect frequency modulated transmitter is given. Also, a discussion of the basic phase lock loop and its application to a phase-locked frequency modulated transmitter is presented.

The phase-locked frequency modulated transmitter is analyzed and equations are derived for reducing the distortion caused by the locking action of the loop. The case of a phase lock loop with a low pass filter is also analyzed.

Finally a discussion of the possible applications of these circuits is presented and two direct frequency modulated transmitters are included as examples.