

NASA CR-72088
TPR 607-1

GPO PRICE \$ _____
CFSTI PRICE(S) \$ _____
Hard copy (HC) 2.00
Microfiche (MF) 1.50

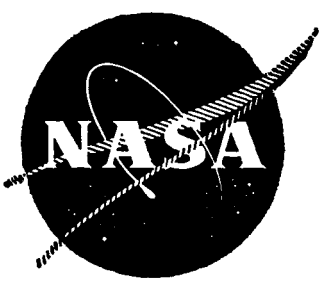

ff 653 July 65

CAVITATION DAMAGE IN LIQUID METALS (Potassium Studies)

by

H. S. Preiser and S. L. Rudy

prepared for

NATIONAL AERONAUTICS AND SPACE ADMINISTRATION

CONTRACT NAS 3-8506

29 SEPT 1966

FACILITY FORM 602	<u>N67 13181</u> (ACCESSION NUMBER)	_____
	<u>39</u> (PAGES)	_____
	<u>CR-72088</u> (NASA CR OR TMX OR AD NUMBER)	_____
		<u>33</u> (CATEGORY)

HYDRONAUTICS, incorporated research in hydrodynamics

Research, consulting, and advanced engineering in the fields of NAVAL and INDUSTRIAL HYDRODYNAMICS. Offices and Laboratory in the Washington, D. C., area: Pindell School Road, Howard County, Laurel, Md.

(over)

NOTICE

This report was prepared as an account of Government sponsored work. Neither the United States, nor the National Aeronautics and Space Administration (NASA), nor any person acting on behalf of NASA:

- (a) Makes any warranty or representation, expressed or implied, with respect to the accuracy, completeness, or usefulness of the information contained in this report, or that the use of any information, apparatus, method, or process disclosed in this report may not infringe privately owned rights; or
- (b) Assumes any liabilities with respect to the use of, or for damages resulting from the use of any information, apparatus, method or process disclosed in this report.

As used above, "person acting on behalf of NASA" includes any employee or contractor of NASA, or employee of such contractor, to the extent that such employee or contractor of NASA, or employee of such contractor prepares, disseminates, or provides access to, any information pursuant to his employment or contract with NASA, or his employment with such contractor.

Requests for copies of this report
should be referred to:

National Aeronautics and Space Administration
Scientific and Technical Information Facility
P. O. Box 33, College Park, Maryland 20740

HYDRONAUTICS, Incorporated

NASA CR-72088

TPR 607-1

TECHNICAL PROGRESS REPORT 607-1

For the Period

10 January 1966 - 31 July 1966

CAVITATION DAMAGE IN LIQUID METALS
(POTASSIUM STUDIES)

By

H. S. Preiser and S. L. Rudy

Prepared for

National Aeronautics and Space Administration

29 September 1966

Contract No. NAS 3-8506

Technical Management

NASA Lewis Research Center

Cleveland, Ohio

Space Power Systems Division

James P. Couch

HYDRONAUTICS, Incorporated

Pindell School Road

Laurel, Maryland

TABLE OF CONTENTS

	Page
ABSTRACT.....	1
I. INTRODUCTION.....	2
II. OBJECTIVES OF THE PROGRAM	3
III. MODIFICATION OF THE TEST FACILITY	4
Retort System.....	5
Potassium Transfer System.....	6
Hot Trap.....	7
Magnetostriction Apparatus.....	8
Elevating Head Seals.....	9
Heating Control Circuits.....	10
IV. CALIBRATION OF THE DRY BOX FACILITY.....	11
Test Chamber.....	12
Pump-Down and Leak Rate.....	12
Oxygen and Moisture Rise.....	12
Oxide Impurity Level in Potassium.....	13
Calibration of the Magnetostriction Device.....	14
V. TEST PROGRAM.....	15
Temperature Studies.....	15
Pressure Parameter Studies.....	16
REFERENCES.....	18

LIST OF FIGURES

- Figure 1 - Overall View of Dry Box Facility
- Figure 2 - Modified Retort System
- Figure 3 - Schematic Potassium Metal Loop for Cavitation Damage Facility
- Figure 4 - Schematic Potassium Hot Trap
- Figure 5 - Magnetostriction Apparatus Assembly
- Figure 6 - Secondary Sealing System for Retort Nozzle
- Figure 7 - Potassium Drum Heating Control Circuits Schematic
- Figure 8 - Rise of O_2 and H_2O in Box Cover Gas (Glove Port Covers Closed)
- Figure 9 - Rise of O_2 and H_2O in Box Cover Gas (Glove Port Covers Open)
- Figure 10 - Magnetostriction Transducer Calibration

LIST OF TABLES

Table 1 - Oxide Impurity Levels in Potassium

Table 2 - Nominal Chemical Composition of Alloys Used in
Cavitation Damage Studies in Liquid Potassium

Table 3 - Some Mechanical Properties of Alloys Under Test

Table 4 - Physical Properties of Potassium

ABSTRACT

The existing dry box facility has been modified and calibrated for conducting high-temperature, liquid-potassium cavitation damage tests. The facility is capable of being operated at temperatures up to 1300°F.

Oxygen and moisture in the argon cover gas in the dry box can be maintained below 5 ppm for 1 hour with the glove ports closed.

An 8-hour potassium purity test under operating conditions was made and oxide impurity levels were maintained well below 50 ppm.

Instrumentation for monitoring amplitude of the magnetostriction device has been installed in the air-cooled free end of the transducer, away from contact with liquid metal vapor.

A program for cavitation damage tests under various temperature and pressure parameters is in progress. The materials selected are TZC, T-111, TiC, and Cb-132M.

AUTHOR

CAVITATION DAMAGE IN LIQUID METALS
(POTASSIUM STUDIES)

Technical Progress Report 607-1
For the Period
10 January 1966 - 31 July 1966

I. INTRODUCTION

High-performance components such as mechanical condensate pumps of a nuclear Rankine-cycle space power plant are anticipated to operate for considerable periods of time in a cavitating environment of high-temperature, alkali liquid metal. The ultimate success of such equipment may depend on the resistance of materials to cavitation damage. High-temperature liquid potassium is currently being considered for the thermodynamic and heat transfer working fluids of these power plants.

Data on the behavior of candidate materials cavitating in high-temperature potassium are virtually nonexistent. One of the objectives of the subject research program, therefore, is to obtain such data. In addition, since liquid-metal condensate pumps of these Rankine-cycle power plants may cavitate under various inlet net positive suction heads (NPSH), the parameters of ambient pressure as well as temperature will be varied to determine their effect on the cavitation damage resistance of the selected materials.

From previous cavitation damage studies in high-temperature liquid sodium (1) under an earlier NASA Contract (NAS 3-4172), an inert atmosphere dry box facility incorporating a magnetostriction apparatus and a liquid metal retort was constructed and

calibrated. The details of this apparatus are described elsewhere (2)(3). In the present study, the facility was converted from liquid sodium to liquid potassium service and means will be provided to maintain retort test pressures independent of the dry box pressures.

II. OBJECTIVES OF THE PROGRAM

The objectives of this program are three-fold:

1. To determine the cavitation damage behavior of selected refractory alloys and 316 stainless steel in liquid potassium at temperatures ranging from 400° to 1200°F.
2. To determine cavitation damage behavior of TZC refractory alloy and 316 stainless steel under pressures ranging from 2 - 40 psia (retort argon pressure minus potassium vapor pressure) up to temperatures of 1300°F.
3. To analyze the data above, to determine the material property (or properties) which controls the cavitation damage resistance of the metals, and to determine the liquid metal property (or properties) which governs the bubble collapse energy for potassium for various temperatures and pressures.

Thus, from these experiments, candidate materials can be ranked for performance in a nuclear Rankine-cycle space power plant under a given set of operating conditions.

III. MODIFICATION OF THE TEST FACILITY

The existing test facility, shown in Figure 1, for conducting cavitation damage experiments on refractory alloys in high-temperature liquid sodium was modified for potassium service as follows:

(a) A new retort and associated vapor trap were designed and installed to withstand independent pressures of 50 psig and 1300^oF.

(b) Sodium piping was replaced with new piping to avoid contamination. Improved transfer system heating was provided.

(c) The hot trap was cleaned and recharged with zirconium gettering material, and modified to permit vapor trapping and rod-out cleaning of vacuum and gas lines to prevent clogging during operation.

(d) The magnetostriction device was recalibrated using an amplitude pick-up device repositioned at the open end of the transducer. A new means of air-cooling was incorporated.

(e) New seals for the elevating head mechanism and retort nozzle were designed and partially installed.

(f) Heating control circuits were modified.

The salient details of the modified facility are described below.

Retort System

A new retort for potassium service capable of withstanding 1300°F and pressures from 10^{-3} torr to 50 psig was constructed of a 5-inch diameter 304 stainless steel tube having a wall thickness of 1/4 inch. A suitable end cap was welded on the bottom end of the tube to which was fitted the existing fill and drain piping system used previously for the sodium experiments. The upper end of the retort was fitted with a mating flange which bolted directly to the floor of the dry box, and was sealed with a metal O-ring. A screen was placed over the drain hole to prevent large particles of foreign material from entering the potassium piping system. The entire fabrication of this component conformed to highest commercial standards for nuclear service. All welds were helium leak tested and found to be free of defects. The essential details of the retort system are shown in Figure 2.

The head of the retort was modified slightly to incorporate a vapor trap system which vents into the dry box. A pressure gage was fitted into the vent system for measuring retort pressures. The schematic details of the vapor trap system are also shown in Figure 2. This arrangement will permit the retort pressure to be maintained at any level independent of the dry box pressure. Whenever specimens are to be removed from the retort for observation and weighing, the retort pressure is equalized to box pressure by either venting the retort atmosphere into the dry box at higher retort pressures or by venting the dry box

atmosphere into the retort at lower retort pressures. The vapor trap is cooled by fastening the entire assembly to the water-cooled floor of the dry box.

One existing thermocouple well (short) in the retort head was removed and a heavy Inconel-sheathed, grounded thermocouple was inserted through a suitable fitting to make direct contact with the upper level of potassium in the retort. This arrangement permits faster thermal response and allows the thermocouple to be used as a secondary liquid level indicator. The primary liquid level indicating method employs an electrical contact through an ungrounded probe as described in the earlier sodium experiments (3).

Potassium Transfer System

A new potassium transfer system was installed, using 3/8 inch O.D. annealed 316 stainless tube (.049 inch wall) to the approximate configuration used for the previous sodium experiments. Transfer system heating was accomplished by wrapping the lines with various lengths of high-temperature fiberglass-insulated heating tape. Each set of heating tapes can be controlled independently by an auto-transformer allowing separate heating of retort, fill and dump, or hot-trap charge lines. These glass-insulated tapes performed so efficiently that no outer thermal insulation over the piping was necessary. Thermocouples fastened to the piping by means of hose clamps are positioned at strategic locations in the piping system to permit a temperature check to be made at elbows, fittings and valves prior to the transfer of potassium.

No trouble was experienced in transferring potassium to any part of the liquid metals loop. The schematic diagram of the potassium loop is shown in Figure 3.

Hot Trap

The cleaned hot trap was further modified by replacing the existing spring-operated bellows-sealed valves (which become inoperative after long-term exposure to high temperatures) with positive-opening bellows-sealed valves.

One of the existing thermocouple wells (short) was removed and replaced by a 3/4-inch O.D., 316 stainless steel tube, .060-inch wall thickness. This larger tube, which connects to the cover gas and vacuum piping, permits the installation of a rod-out system to clear the line of potassium residues which are expected to accumulate during prolonged operation. A suitable vapor trap was incorporated in the cover gas and vacuum piping to confine the potassium vapor to that section of piping containing the rod-out mechanism.

Heavy Inconel-sheathed, Chromel-Alumel, grounded thermocouples were inserted into existing piping connections in the hot trap to make direct contact with the potassium. These fast-response thermocouples provide a liquid level indicating system; a long thermocouple indicates the beginning of fill and the short thermocouple indicates the upper level of filling for the hot trap. This system has worked so well that the design of a direct weighing system for measuring the amount of potassium charge in the hot trap was abandoned.

The hot trap is cycled automatically to maintain a 1250°F temperature overnight for 12 hours and then cooled down so that potassium can be transferred at about 500°F at the start of the working day. A high-temperature safety cutout on the hot trap furnace prevents the possibility of over-heating during unattended periods. Figure 4 shows a schematic diagram of the modified hot trap and associated instrumentation.

Magnetostriction Apparatus

The magnetostriction apparatus was modified to permit the amplitude pick-up coil to be relocated on the open end of the transducer to avoid contact with potassium vapor. Previous experience with sodium, where the pick-up coil was positioned on the exponential horn and exposed to liquid metal vapor at elevated temperature, showed frequent failure of electrical insulation on the pick-up coil. After trying several schemes, including an accelerometer and a piezoelectric crystal (both of which overheated at the point of attachment to the transducer), the original pick-up coil was used in conjunction with a resonant extension rod attached to one leg of the free end of the transducer. Much trouble was experienced at the soldered joint between the mounting plate and the transducer. At high-power input, the heat generated at the joint melted the solder and loosened the attachment of the voice-coil extension rod. The final configuration using a titanium rod and mild steel, tapered stub is shown in Figure 5. This arrangement eliminated the need for special seals and allowed cooling by forced-air circulation.

The heat developed in the transducer stack had been previously dissipated by immersion in a water-cooled kerosene bath. For additional safety reasons, it was decided to eliminate all liquid cooling and use only compressed-air flow to remove the heat developed by the transducer. Compressed air from our shop supply was passed through a high-efficiency, water-cooled heat exchanger and expanded rapidly through an expansion valve prior to entering a drilled circular ring located inside the tubular housing at the bottom of the transducer assembly. Radially swirling cool air blows over the transducer stack maintaining proper operating temperatures. The schematic details of the air-cooling system are shown in Figure 5.

Elevating Head Seals

The elevating head system had to be completely disassembled and cleaned. The tubular housing was scored from dust and grit entrapment on the sliding seals. The score marks were removed and the external surface of the tubular housing was repolished to a mirror finish. A felt wiper ring was installed in the upper opening of the seal well of the elevating mechanism housing. This prevents foreign matter from entering the housing seal. An accordion-type, Buna-N rubber boot will be attached to the compression cap and bolted onto the transducer housing so that any metallic vapor in the dry box will be prevented from being deposited on the polished sliding tubular surface.

Much difficulty was experienced in realigning the elevating mechanism, jack-screw assembly so that the male telescopic housing mates concentrically and perpendicularly with the female nozzle seal on the retort. This is due to the unsupported and relatively long travel of the tubular housing along the jack screws prior to mating with the retort. For the initial experiments which are to be conducted at ambient retort pressures, minor misalignment can be tolerated, as the seal only prevents potassium vapor from entering the dry box during a test. For the pressure experiments, positive-sealing means must be maintained and therefore the elevating mechanism will have to be fitted with guide bars and a modified retort sealing system be installed. Figure 6 shows the design of a back-up nozzle seal to prevent splattering of potassium in the event of an internal O-ring failure.

Heating Control Circuits

Several improvements were made in the facility heating system. The retort furnace previously used for sodium experiments failed and was replaced by a more serviceable, higher wattage unit providing faster heat-up and more accurate temperature control. Four quarter-circular, high-temperature ceramic heaters are clamped around the retort and rest on an insulating base. The entire assembly is then wrapped with several layers of fiberglass insulation. Each opposing pair of heaters can be controlled by a switch. This arrangement allows the use of half or full power, as required, under pyrometer control. The furnace operates efficiently and can easily maintain retort temperatures of 1500°F.

The potassium fill and dump drums were fitted with band heaters which have separate thermostatic temperature controls. In addition, two ring heaters with separate proportional controls are mounted under each drum; these are used primarily for rapid heat-up in conjunction with the band heaters until the desired drum temperature is obtained. The potassium drum-heating schematic is shown in Figure 7.

The modified dry box and associated systems have been checked for proper operation and found to perform their intended function. The next section describes the calibration of the facility.

IV. CALIBRATION OF THE DRY BOX FACILITY

The performance standards for the dry box as set forth by NASA are, as follows:

(a) The test chamber, with its glove-port cover plates in place, shall be capable of maintaining the argon purity below 5 ppm oxygen and 5 ppm water for a period of one hour.

(b) The oxygen content of the liquid potassium in the retort shall be maintained below 50 ppm over an 8-hour day of normal operation.

In addition to the above, the amplitude of the magnetostriction apparatus was calibrated, the oxygen and moisture rise was recorded with glove-port cover plates off, and pump-down pressure of the dry box was observed with a McLeod gage. All instrumentation was checked and adjusted, and all systems were operated and their performance observed over their designed range.

Test Chamber

Pump-Down and Leak Rate - The vacuum manifold with the blank-off valve closed was capable of being pumped down to 3 millitorr as measured by a McLeod gage after a 72-hour initial pump-down. The pressure in the dry box was measured at 4 millitorr. The Pirani gages showed higher readings than the McLeod gage; however, the calibration of the Pirani gages is less accurate.

Rise of pressure with time inside the dry box was recorded over several runs: this averaged about 35 millitorr per hour. These initial readings were higher than those obtained in the previous sodium experiment; however, from subsequent measurements of oxygen and moisture rates of rise in the dry box, these values appeared adequate for the present experiment. Incidentally the higher pump-down pressure is probably due to minor wear of the wiper vanes of the mechanical pump. Also, the higher in-leak rate is attributable to minuscule cover gas through-leaks from the cylinders through the valves in the manifold.

Oxygen and Moisture Rise - The moisture analyzer and oxygen analyzer were recalibrated by a factory service representative. All worn parts were renewed including the electrolytic cells. Argon gas was monitored at the manifold prior to entering the dry box and was found to contain 0.5 ppm O_2 and 1.5 ppm H_2O . Argon was back-flushed into the dry box (after overnight pump-down) and allowed to come to atmospheric pressure. The analyzers were switched to sample the box gas. With the glove-port covers in place, the moisture rose almost linearly from 1.5 to 5 ppm in

one hour and the oxygen climbed rapidly to about 4 ppm and then remained practically constant for the one hour run, stabilizing at 3.5 ppm. Figure 8 shows the moisture and O₂ rise as a function of time.

The rise in moisture and oxygen with the glove ports open was also recorded. The gloves in use were a sulfur-free Butyl rubber glove, 30 mils thick, in the right side and a PVC 30-mil glove in the left side. The PVC glove replaced a faulty (punctured) Butyl glove since no spare was available. These Butyl gloves are being tried on an experimental basis. Figure 9 shows the rate of rise of moisture and O₂ which compares favorably with values obtained in previous experiments; average rate of rise for oxygen is about 12 ppm/hr, and for moisture, 30 ppm/hr.

Oxide Impurity Level in Potassium

Preparations were made to calibrate the oxide impurity level of liquid potassium heated in the retort and exposed to the dry box atmosphere over a normal 8-hour working period. The potassium had to be transferred from the storage drum to the hot trap where it was hot-trapped for a minimum of 72 hours at 1250^oF. Potassium sample capsules were made from 3/4-inch diameter, .028-inch wall, 316 stainless steel tubing, 6 inches in length and capped on both ends. The capsules were degreased in acetone, carefully washed and baked out in vacuum prior to use. Each capsule could contain a 20-gram sample of potassium. The potassium samples are sent to Atomic Power Development Associates

in Detroit, Michigan, for analysis by a modified mercury amalgamation technique. Neutron activation analyses were considered but, in view of low confidence limit for detecting oxygen limits below 50 ppm and the need to use container material having less than 10 ppm of oxygen (commercially unavailable), this method of testing was abandoned.

Each of the four potassium samples were taken by the dip tube method used previously for sodium sampling. Several dips were required to fill a sample capsule with potassium. During the entire sampling period, representing about 4-1/2 hours of a normal working day, glove ports were operated intermittently, the elevating mechanism was operated and a specimen was tested and removed from the box through the specimen lock. The dry box was pumped down after the first sampling, since the moisture level rose to 65 ppm. The results of this calibration are contained in Table 1.

Calibration of the Magnetostriction Device

The double amplitude and resonant frequency of the magnetostriction device were calibrated by means of a filar microscope and an oscilloscope voltage display of the voice-coil output. With the displacement pickup coil located in the new position, as shown in Figure 5, the peak-to-peak travel of specimens was measured as a function of mv output of the oscilloscope as plotted in Figure 10. The resonant frequency of the magnetostriction assembly at these amplitudes was 14 kcs.

When the air-cooling system for the transducer stack was operated, the air outlet temperature, at 0.5 cfm directed at the stack, was recorded to be 54^oF. Under these conditions, the stack temperatures at full power remained below 150^oF which is considered to be satisfactory.

All other components associated with the facility were checked for proper operation. It was concluded that the facility is ready for conducting the necessary experiments required for the research program.

V. TEST PROGRAM

The test program is divided into two experimental phases:

- (a) Temperature Studies
- (b) Pressure Parameter Studies

Temperature Studies

On the basis of their high strength and other desirable properties at elevated temperatures, five candidate materials have been selected by NASA for determining their cavitation damage resistance in liquid potassium over three temperature ranges: 400^oF, 800^oF, and 1200^oF. The test materials whose chemical compositions are given in Table 2 are listed as follows:

- (a) 316 stainless steel,
- (b) T-111 alloy,
- (c) TZC alloy in two conditions of heat treatment:
recrystallized and stress-relieved,
- (d) Cb-132M alloy in two conditions of heat treatment:
recrystallized and stress-relieved, and
- (e) TiC + 10 percent Cb binder. These specimens are
to be furnished by NASA in the form of 1/4 inch
thickness discs, 5/8 inch diameters, which will
be brazed to Cb-1 Zr cavitation button stubs.

The rate of volume loss for these alloys will be determined as a function of test duration. The damage rates in the steady state zone will be compared to that of 316 stainless steel, chosen as a control because of its extensive use as a containment material for high-temperature, alkali metals.

The pressure parameter (retort argon pressure minus potassium vapor pressure) will be kept constant at 15 ± 1 psia throughout these tests.

Pressure Parameter Studies

The second phase of the experimental program will be to determine the effect of the pressure parameter on the cavitation damage sustained by two of the materials tested in the temperature studies: 316 stainless steel and the TZC alloy in one of

the previous heat-treated conditions. The pressure parameter (which roughly corresponds to NPSH of a pump) will vary from 2 ± 1 psia to 40 ± 1 psia with temperature ranges for potassium of 400°F to 1300°F . Twelve retort pressure levels are to be tested.

The experimental data obtained from the above two phases will be analyzed to determine what material properties and liquid parameters govern the rate of cavitation damage to the material. Table 3 lists some of the more important physical properties of the metals under consideration. Table 4 gives the salient physical properties of liquid potassium.

The next technical progress report will cover the experimental studies on cavitation damage as a function of temperature.

REFERENCES

1. Thiruvengadam, A., and Preiser, H. S., "Cavitation Damage in Liquid Metals," HYDRONAUTICS, Incorporated Technical Report 467-Final, NASA CR-72035, November 1965.
2. Couchman, C. E., III, Preiser, H. S., and Thiruvengadam, A., "Cavitation Damage in Liquid Metals," HYDRONAUTICS, Incorporated Technical Progress Report 467-1, NASA CR-54332, March 10, 1965.
3. Preiser, H. S., Thiruvengadam, A., and Couchman, C. E., III, "Cavitation Damage in Liquid Sodium," HYDRONAUTICS, Incorporated Technical Report 235-1, July 1964.
4. Coe, H. H., "Summary of Thermophysical Properties of Potassium," NASA TN D-3120, December 1965.

TABLE 1

Oxide Impurity Levels in Potassium*

Time	Sample No.	Box O ₂ (ppm)	Box H ₂ O (ppm)	Potassium Temp. (°F)	Oxide Impurity (ppm)
3:20 PM	1	4	20	300	6
4:50 PM**	2	1.5	15	300	6
6:21 PM	3	3	19	300	7
7:50 PM	4	6	70	300	5

* All samples were taken in the retort under dry box argon atmosphere on 7-28-66.

** Box was pumped down and back-flushed with argon.

Note: Cover gas measured at manifold contained 0.4 ppm O₂ and 2.2 ppm H₂O.

TABLE 2

Nominal Chemical Composition of Alloys Used In
Cavitation Damage Studies in Liquid Potassium
(Weight Percent*)

Metal	Cr	Ni	Mo	Mn	Si	C	P	S	Fe	
316 Stainless Steel	16-18	11-14	2-3	2.0	0.75	0.08	0.03	0.03	Bal.	
T-111	W	Hf	Ta	Cb	Mo	O	Fe	C		
	7.87	2.03	Bal.	110ppm	100ppm	25ppm	20ppm	10ppm		
	N	H	Ni	V	Co					
TZC	10ppm	10ppm	10ppm	10ppm	10ppm					
	Ti	Zr	C	Mo						
CB-132M	1.36	0.36	0.095	Bal.						
	Ta	W	Mo	Zr	C	Cb	Cu	Cr	Mn	V
	19.81	15.01	5.07	2.17	0.15	Bal.	750ppm	720ppm	710ppm	710ppm
	Ni	Ti	Al	Mg	Fe	Na		Si	H ₂	O ₂
	710ppm	710ppm	710ppm	72ppm	35ppm	26-28ppm	15ppm	4.1ppm	4ppm	
TiC + 10 Percent Cb Binder	Composition not available									
* Except where otherwise specified.										

TABLE 3

Some Mechanical Properties of Alloys Under Test
(Room Temperature)

Material	Yield Strength (psi)	Tensile Strength (psi)	Elongation in 2"* %
T-111	73,000	89,600	(in 1") 42
CB-132M	109,800	121,200	4.2
316 stainless steel	68,000	91,400	36
Class A TZC	60,000 - 90,000	80,000 - 110,000	(in 4D) 5
Class B**	100,000 - 140,000	125,000 - 175,000	(in 4D) 15
TiC + 10% Cb Binder	-	-	-
<p>* Except where otherwise specified. ** Parallel to direction of work.</p>			

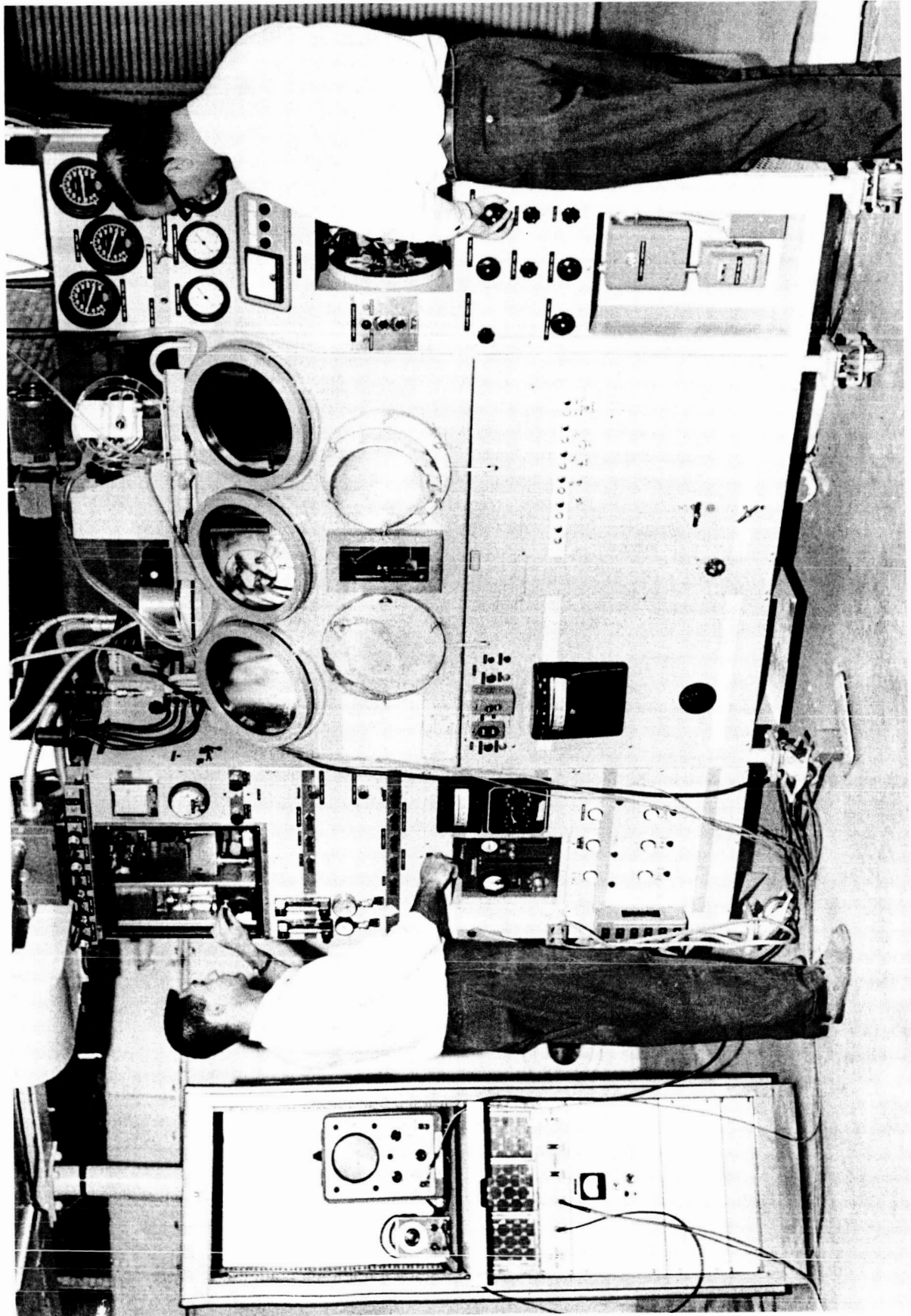

FIGURE 1 - OVERALL VIEW OF DRY BOX FACILITY

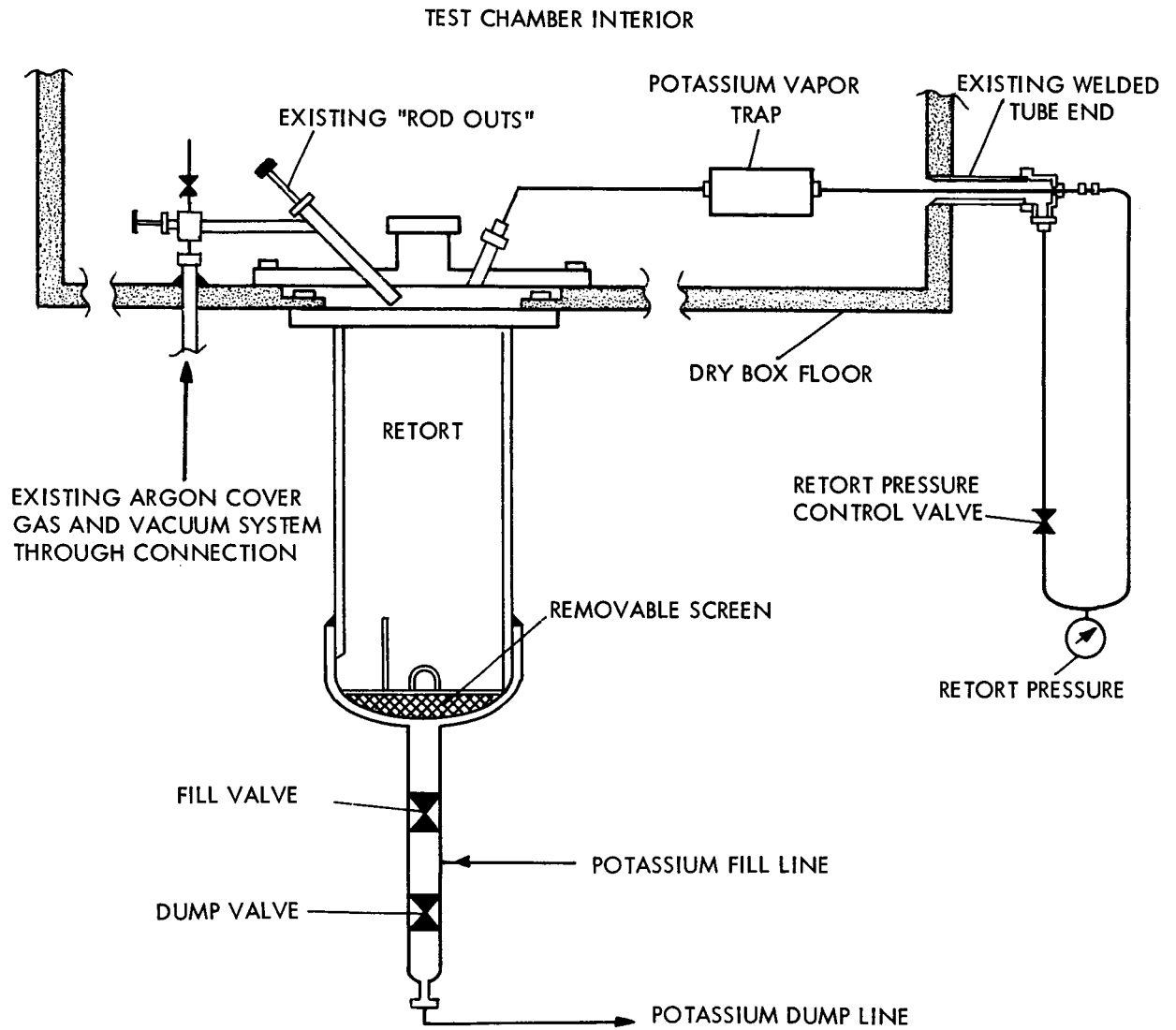

FIGURE 2 - MODIFIED RETORT SYSTEM

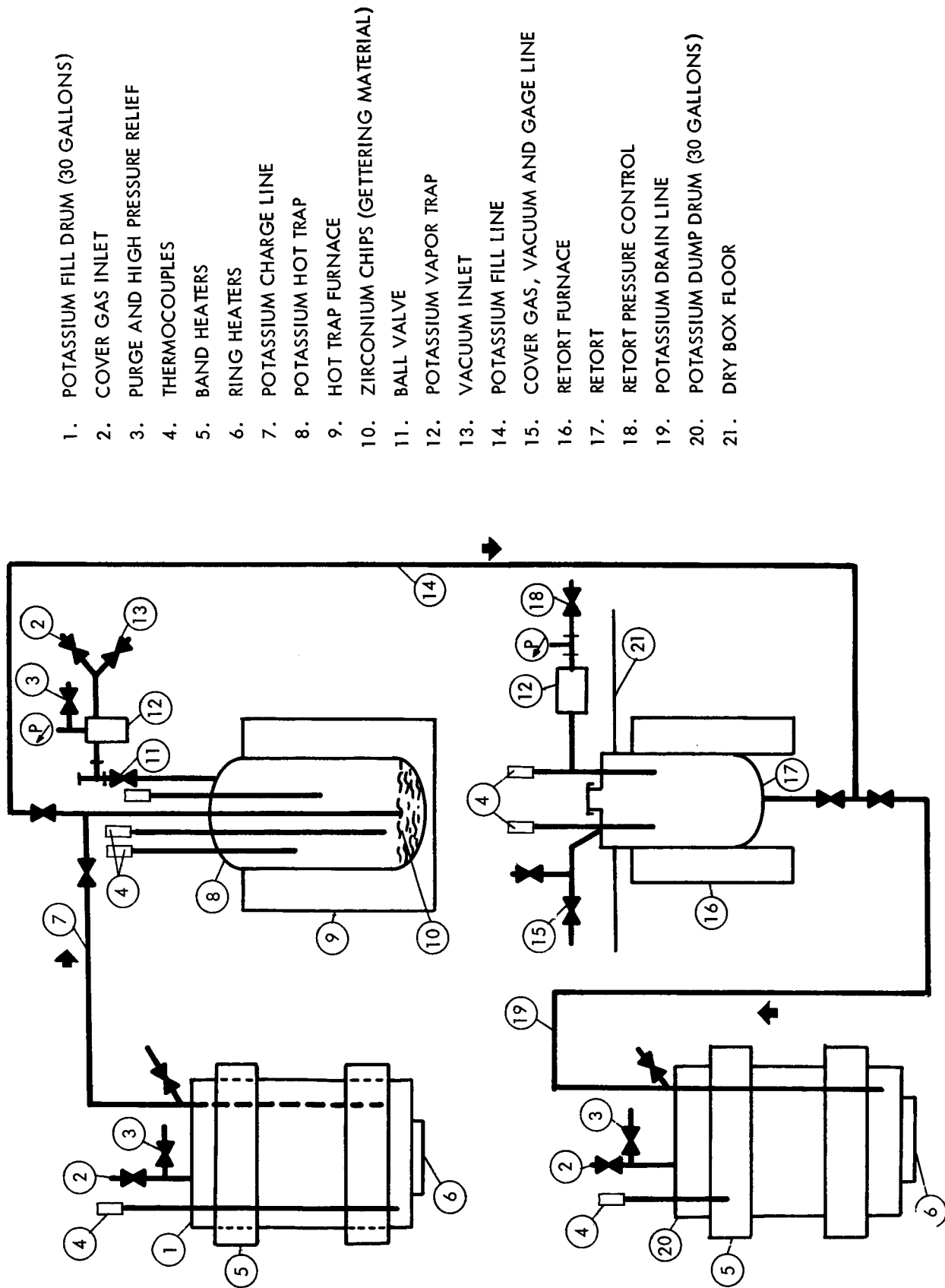
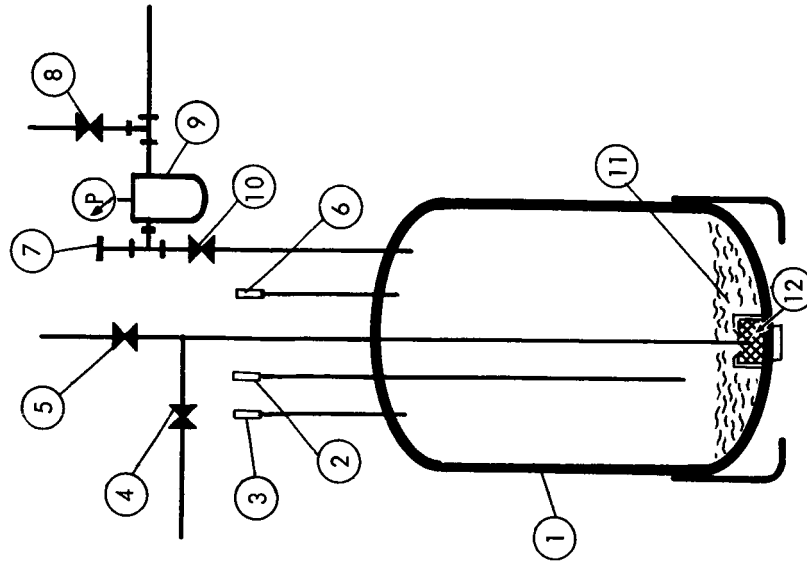
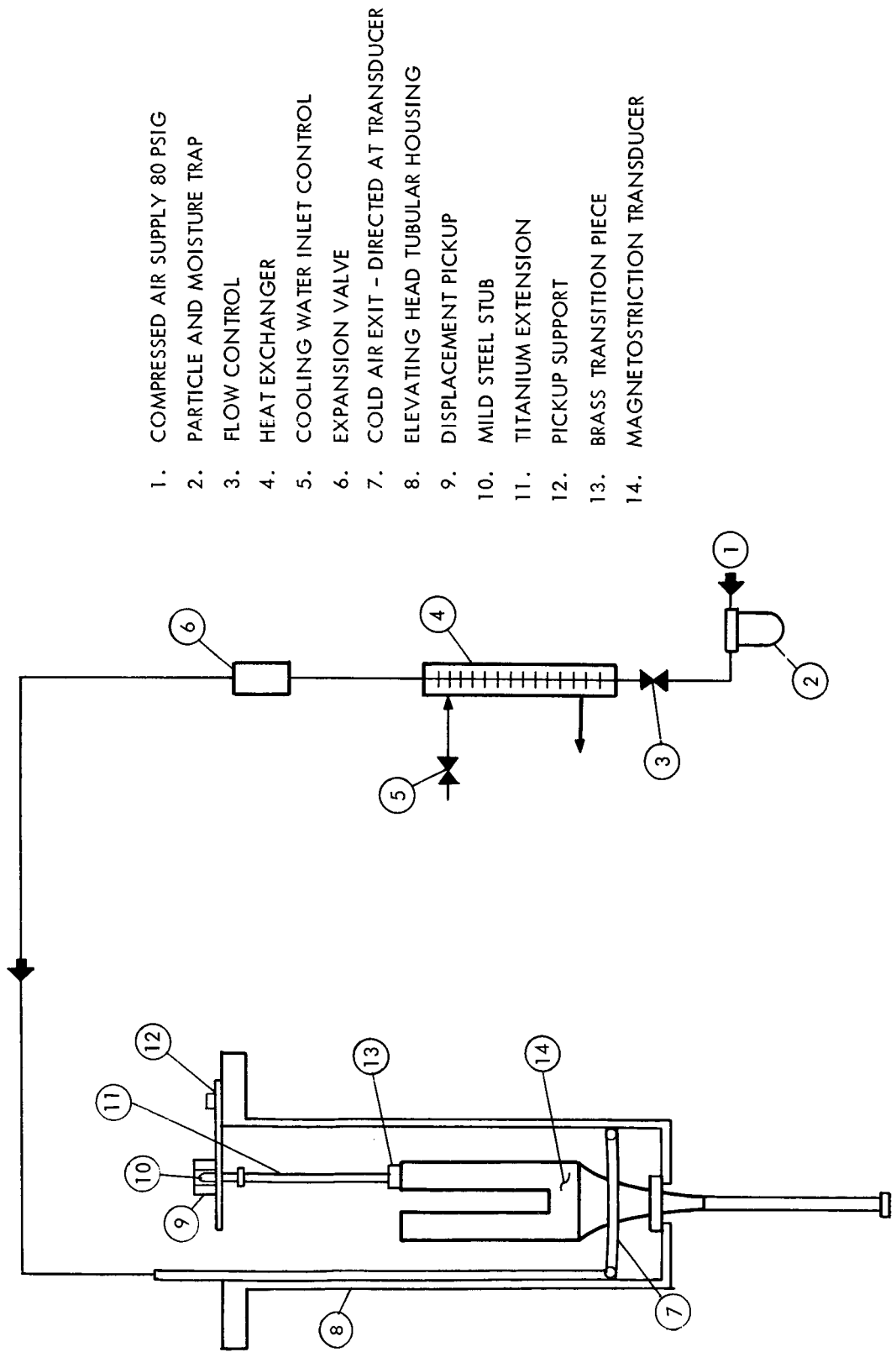

FIGURE 3 - SCHEMATIC POTASSIUM METAL LOOP FOR CAVITATION DAMAGE FACILITY



1. HOT TRAP BODY
2. LOW LEVEL INDICATOR THERMOCOUPLE
3. HIGH LEVEL INDICATOR THERMOCOUPLE
4. POTASSIUM CHARGE VALVE
5. POTASSIUM FILL VALVE
6. HIGH TEMPERATURE FURNACE CUTOFF T.C.
7. ROD-OUT SYSTEM
8. ARGON PURGE AND RELIEF
9. VAPOR TRAP
10. 1" BALL VALVE TO ISOLATE COMPONENTS ABOVE WHILE HOT TRAPPING
11. ZIRCONIUM CHIPS
12. WIRE MESH STRAINER AROUND DIP TUBE

FIGURE 4 - SCHEMATIC POTASSIUM HOT TRAP



1. COMPRESSED AIR SUPPLY 80 PSIG
2. PARTICLE AND MOISTURE TRAP
3. FLOW CONTROL
4. HEAT EXCHANGER
5. COOLING WATER INLET CONTROL
6. EXPANSION VALVE
7. COLD AIR EXIT - DIRECTED AT TRANSDUCER
8. ELEVATING HEAD TUBULAR HOUSING
9. DISPLACEMENT PICKUP
10. MILD STEEL STUB
11. TITANIUM EXTENSION
12. PICKUP SUPPORT
13. BRASS TRANSITION PIECE
14. MAGNETOSTRICTION TRANSDUCER

FIGURE 5 - MAGNETOSTRICTION APPARATUS ASSEMBLY

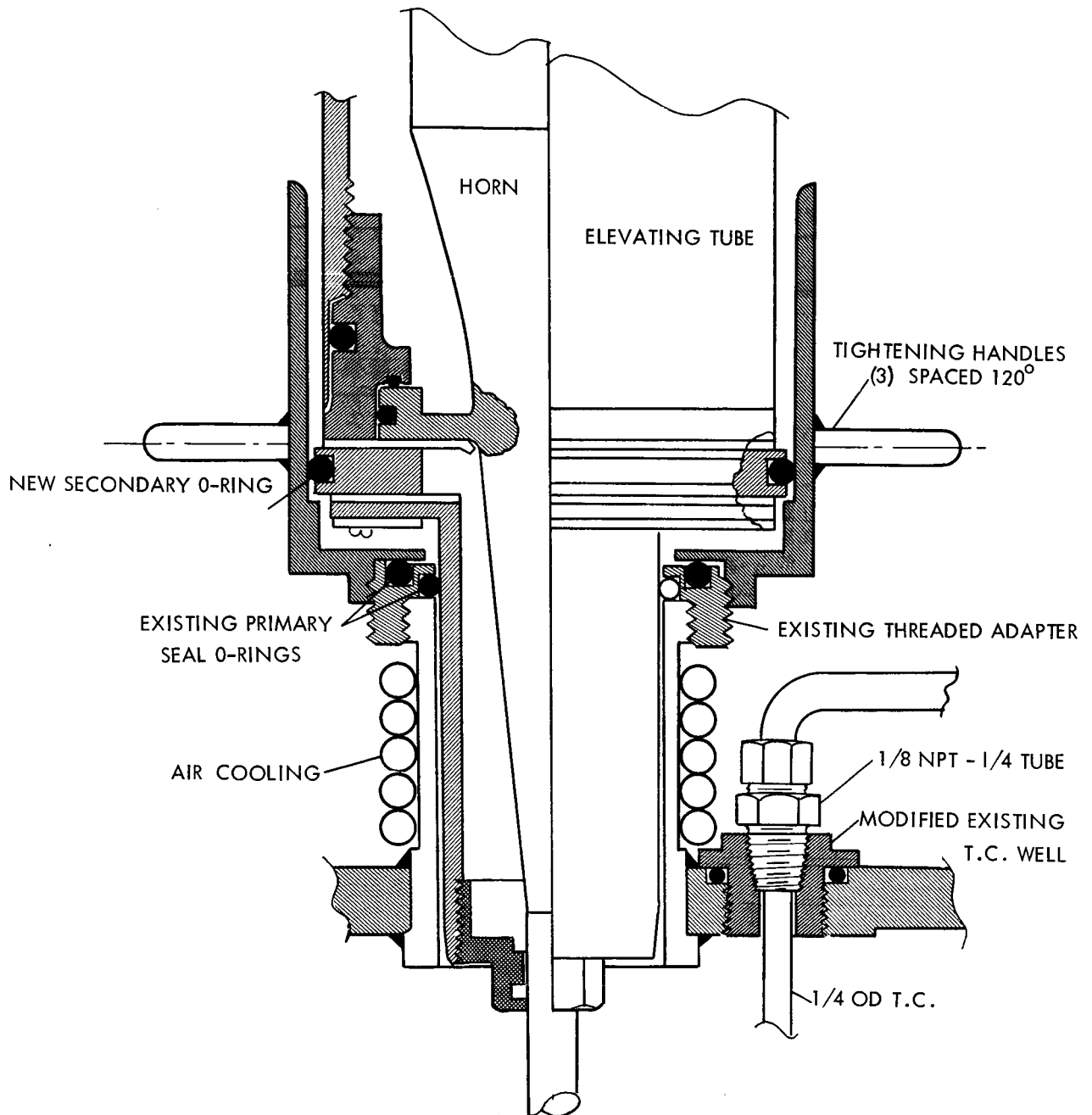

FIGURE 6 - SECONDARY SEALING SYSTEM FOR RETORT NOZZLE
(PRESSURE EXPERIMENTS)

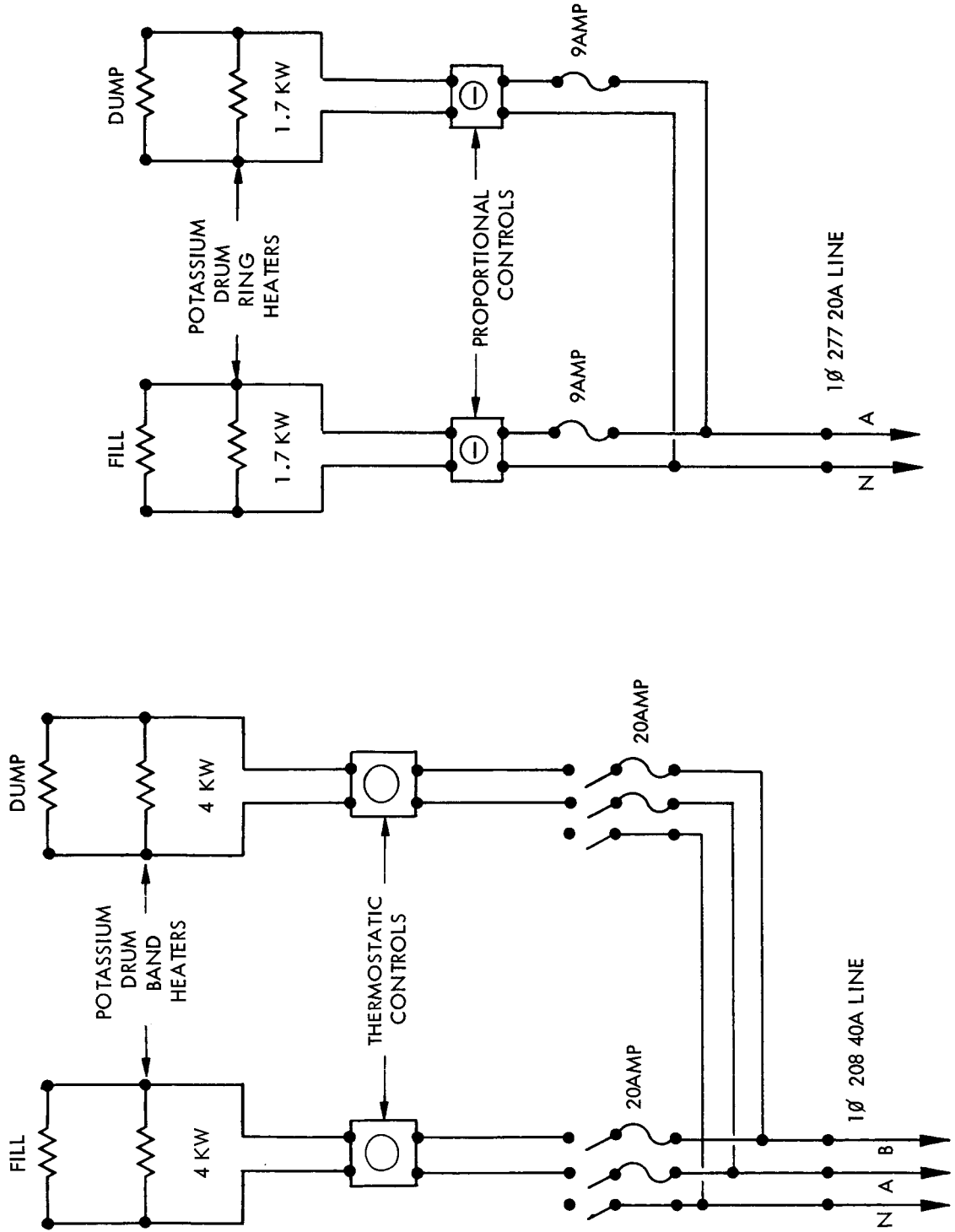

FIGURE 7 - POTASSIUM DRUM HEATING CONTROL CIRCUITS SCHEMATIC

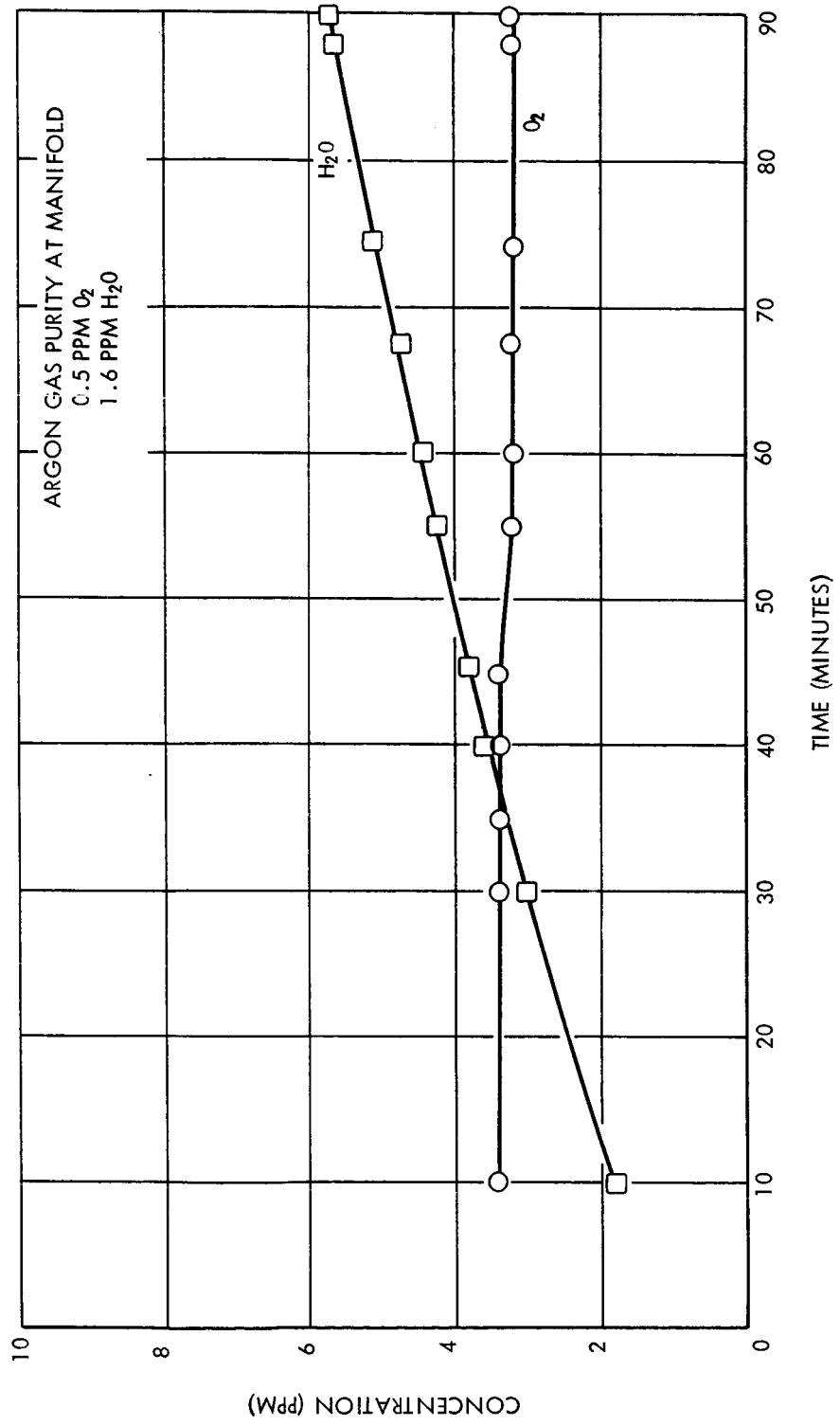

FIGURE 8 - RISE OF O₂ AND H₂O IN BOX COVER GAS (GLOVE PORT COVERS CLOSED)

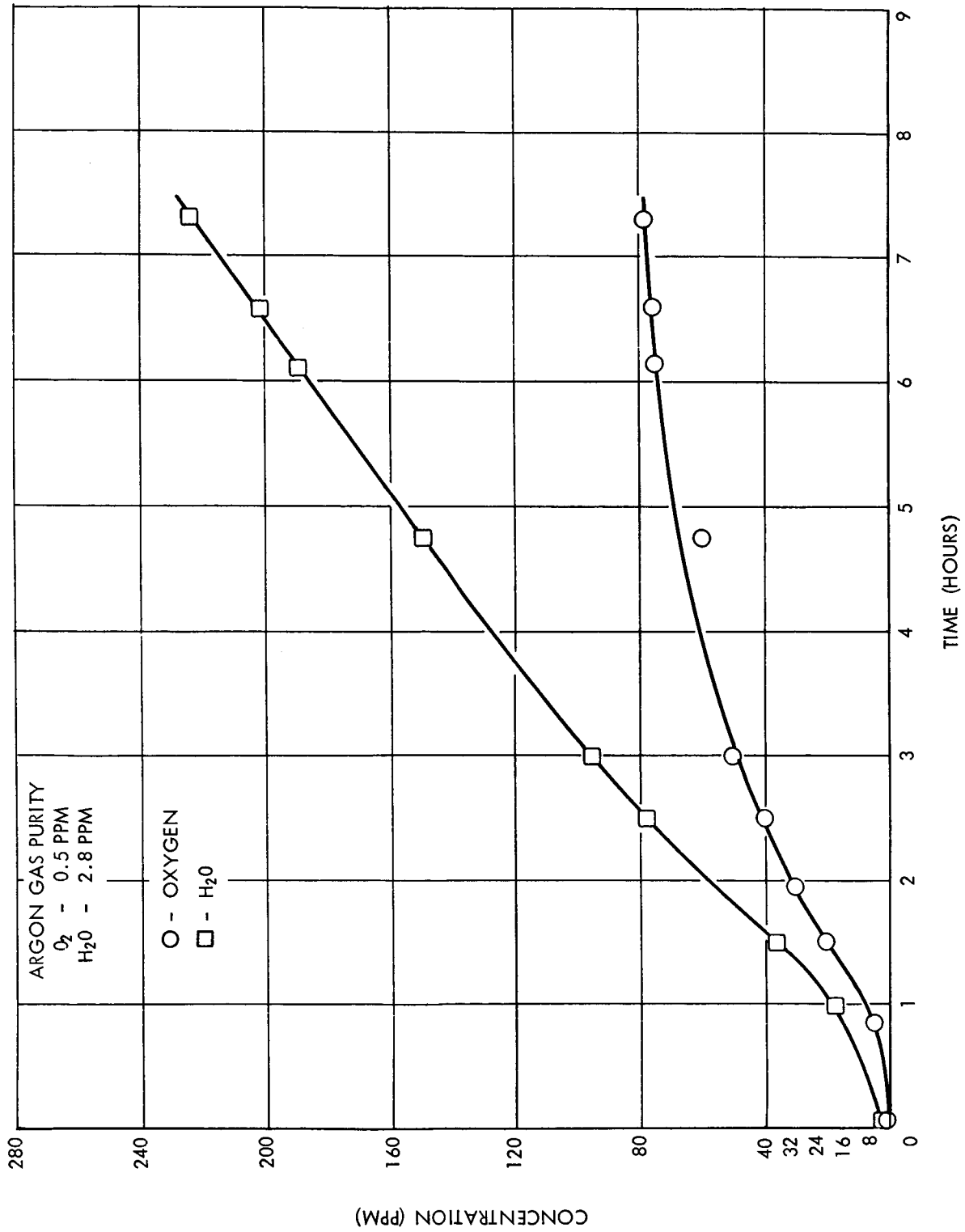

FIGURE 9 - RISE OF O₂ AND H₂O IN BOX COVER GAS (GLOVE PORT COVERS OPEN)

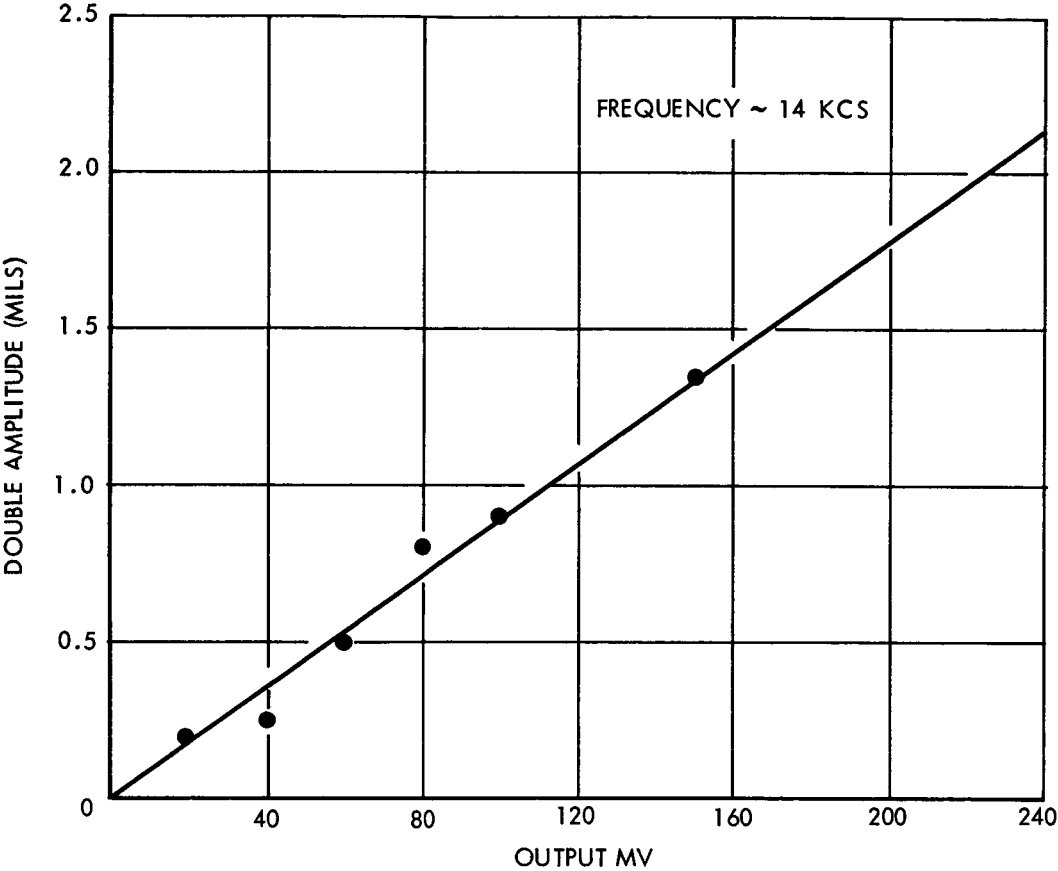

FIGURE 10 - MAGNETOSTRICTION TRANSDUCER CALIBRATION

HYDRONAUTICS, Incorporated

-2-

Air Force Systems Command Aeronautical Systems Div. Wright-Patterson AFB, Ohio 45438 Attn: K. A. Davis (MANL)	1	Atomics International Liquid Metals Inf. Center P. O. Box 309 Canoga Park, California 91304 Attn: R.W. Dickinson	1
Defense Documentation Center Cameron Station 5010 Duke Street Alexandria, Virginia 22314	2	Defense Metals Inf. Center Battelle Memorial Institute 505 King Avenue Columbus, Ohio 43201	1
Aerojet-General Corporation SNAP-8 Division Azusa, California 91703 Attn: Dr. Robert Gordon	1	Allis-Chalmers Mfg. Co. York, Penn. Attn: W. J. Rheingans	1
General Electric Company Missile and Space Division Space Power and Propulsion Section Cincinnati, Ohio 45215 Attn: Dr. J. W. Semmel Dr. Oliver Engle	1 1	TRW Inc. Electromechanical Division 23555 Euclid Avenue Cleveland, Ohio 44117 Attn: J. N. McCarthy	1
University of Michigan Nuclear Engineering Dept. Ann Arbor, Michigan 48103 Attn: Dr. F.G. Hammitt	1	Philco Corporation Aeronutronic Division Ford Road Newport Beach, Calif. 92660 Attn: H.D. Lindhardt	1
California Institute of Tech. Dept. of Applied Mechanics Pasadena, California 91103 Attn: Dr. M. S. Plesset	1	United Aircraft Corporation Pratt and Whitney Aircraft Div. 400 Main Street East Hartford, Conn. 06108 Attn: Dr.W. J. Lueckel	1
Westinghouse Electric Corporation Astronuclear Laboratory Box 10864 Pittsburgh, Penn. 15236 Attn: R. T. Begley	1	National Aero and Space Adm. Jet Propulsion Laboratory 4800 Oak Grove Drive Pasadena, Calif. 91103 Attn: Dr. Lance Hayes	1

•
• HYDRONAUTICS, Incorporated

-3-

North American Aviation, Inc.
Rocketdyne Division
6633 Canoga Avenue
Canoga Park, California 91303
Attn: Robert Spies 1

Westinghouse Electric Corporation
Astronuclear Laboratory
P. O. Box 10864
Pittsburgh, Pennsylvania 15236
Attn: W. D. Pouchot 1