

FACILITY FORM 802

N67 19044
(ACCESSION NUMBER)

110
(PAGES)

CR-82373
(NASA CR OR TMX OR AD NUMBER)

(THRU)

07
(CODE)

(CATEGORY)

Antenna Laboratory Report No. 66-18

ANTENNA IMPEDANCE IN A WARM PLASMA

by
J. W. Carlin
R. Mittra

Scientific Report No. 9

December 1966

Sponsored by
National Aeronautics and Space Administration
NSG 395

Antenna Laboratory
Department of Electrical Engineering
Engineering Experiment Station
University of Illinois
Urbana, Illinois

ABSTRACT

Expressions have been derived for the impedance of biconical and cylindrical dipoles in a warm isotropic plasma. A linearized hydrodynamic description was used as a plasma model. Collisions were neglected throughout as they should modify only the quantitative effects and not the qualitative effects of "plasma" waves on impedance.

In determining the impedance of a cylindrical dipole in intimate contact with a plasma, the effect of the induced acoustic sources (force and fluid flux distributions) on the antenna surface must be accounted for in addition to the effects of the induced current distribution. This was accomplished by derivation of a suitable stationary formula for impedance which accounts for the effects of all the induced sources. The main advantage of this type of formulation is that it is only necessary to know the functional form of the induced sources and not their relative magnitudes in order to obtain impedance values. This, of course, is an inherent property of the variational formulation. In general, the effect of the acoustic sources on impedance was found to be quite small, except in certain instances.

In the treatment of a biconical dipole the antenna was assumed to be encased in an insulating dielectric which is immersed in a plasma. For this model an exact expression was derived for the terminal admittance for very thin antennas. For wide angle dipoles a variational expression, which depends on the aperture tangential electric field, was derived. The admittance was found to be strongly dependent on the ratio of the velocity of light in free space to the

acoustic velocity in the plasma. Compressibility effects seem to be quite significant if the acoustical "phase length" of the antenna is approximately 20 or less. The presence of an ion sheath decreased the power radiated in the "plasma" wave.

ACKNOWLEDGMENT

Financial support was provided in part by the National Aeronautics and Space Administration under Grant NSG 395. It is also a pleasure to acknowledge the support of an NSF traineeship.

TABLE OF CONTENTS

	Page
I. INTRODUCTION	1
II. FORMULATION OF THE IMPEDANCE PROBLEM FOR A CYLINDRICAL DIPOLE IN A WARM PLASMA	6
<u>2.1 Basic Equations and a Statement of the Reciprocity Principle for a Warm Plasma</u>	6
<u>2.2 Variational Expression for the Impedance of a General Antenna in a Warm Plasma</u>	11
<u>2.3 Transform Solution of the Wave Equations and a Formula for the Impedance of a Short Dipole</u>	19
<u>2.4 Numerical Computations and Discussion of Results</u>	37
III. THE IMPEDANCE OF A BICONICAL DIPOLE IN A WARM PLASMA	44
<u>3.1 Formulation of the Problem in a Spherical Geometry</u>	44
<u>3.2 The Thin Biconical Dipole</u>	49
<u>3.3 The Thick Biconical Dipole</u>	55
<u>3.4 Numerical Computations and Discussion of Results</u>	64
IV. CONCLUSION	82
REFERENCES	86
ADDITIONAL REFERENCES ON RELATED TOPICS	89

LIST OF TABLES

Table	Page
1. Effects of Electrical Phase Length ($\alpha_e \ell$) on Impedance; $X = 1.25$, $\alpha_p \ell = 20$, $\rho = .05$	38
2. Effects of $\alpha_p \ell$ on Impedance; $X = 1.25$, $\rho = .05$, $c/u = 100$	39
3. Effects of X on impedance; $\alpha_p \ell = 10$, $\rho = .05$, $c/u = 100$	40
4. Effects of $k_e \ell$ on Impedance; $X = .70$, $\rho = .05$, $k_p \ell = 20$	42
5. Effects of $k_p \ell$ on Impedance; $X = .70$, $\rho = .05$, $c/u = 100$	42
6. Effects of X on Impedance; $k_p \ell = 10$, $\rho = .05$, $c/u = 100$	43

LIST OF ILLUSTRATIONS

Figure	Page
1. Geometry used in determination of reciprocity principle	9
2. Problem geometry and the equivalent surface source distributions	12
3. Problem geometry and the assumed current and force distributions	21
4. Contour of integration used in determining inverse Hankel transform	30
5. Problem geometry	45
6. $K^2 Y_t = G_{a,d} + j B_{a,d}$ for a thin biconical antenna radiating into a warm plasma	66
7. $Z_{in} = R_{a,d} + j X_{a,d}$ for a thin biconical antenna radiating into a warm plasma, $K = 500$ ohms	67
8. $K^2 Y_t = G_{a,d} + j B_{a,d}$ for a thin biconical antenna radiating into a warm plasma	69
9. $Z_{in} = R_{a,d} + j X_{a,d}$ for a thin biconical antenna radiating into a warm plasma, $K = 500$ ohms	70
10. Effects of temperature (c/u) on $K^2 Y_t (G_{a,d} + j B_{a,d})$ for a thin antenna	72
11. Effects of temperature (c/u) on $Z_{in} (R_{a,d} + j X_{a,d})$ for a thin antenna, $K = 500$ ohms	73
12. $K^2 Y_t = G_{a,d} + j B_{a,d}$ for a thick biconical antenna ($\theta_o = 66.06^\circ$) radiating into a warm plasma	74
13. $Z_{in} = R_{a,d} + j X_{a,d}$ for a thick biconical antenna ($\theta_o = 66.06^\circ$) radiating into a warm plasma	75
14. $Z_{in} = R_{a,d} + j X_{a,d}$ for a thick biconical antenna ($\theta_o = 66.06^\circ$) radiating into an ion sheath and a warm plasma	77

LIST OF ILLUSTRATIONS (continued)

Figure		Page
15.	Effects of temperature (c/u) on $K^2 Y_t (G_{a,d} + j B_{a,d})$ for a thick antenna ($\theta_o = 66.06^\circ$)	78
16.	Effects of temperature (c/u) on $Z_{in} (R_{a,d} + j X_{a,d})$ for a thick antenna ($\theta_o = 66.06^\circ$)	79
17.	Effects of temperature (c/u) on $K^2 Y_t (G_{a,d} + j B_{a,d})$ for a thick antenna ($\theta_o = 66.06^\circ, k_o \ell = .01$)	80
18.	Effects of temperature (c/u) on $Z_{in} (R_{a,d} + j X_{a,d})$ for a thick antenna ($\theta_o = 66.06^\circ, k_o \ell = .01$)	81

LIST OF SYMBOLS

- $\alpha_e = \sqrt{X-1} k_0$ = attenuation constant for EM waves when $\omega < \omega_p$
 $\alpha_p = (c/u)\alpha_e$ = attenuation constant for acoustic waves when $\omega < \omega_p$
 $\alpha_e \lambda$ = electrical "phase length" when $\omega < \omega_p$
 $\alpha_p \lambda$ = acoustical "phase length" when $\omega < \omega_p$
 α = impedance constant for metallic conductor in a warm plasma which relates the normal component of velocity and pressure
 a = radius of cylindrical dipole, or radius of ion sheath for biconical dipole
 $B_{a(d)}$ = imaginary part of $K^2 Y_t$ with (or without) acoustic effects
 c = velocity of light in free space
 ϵ_0 = free space dielectric constant
 $\epsilon = \epsilon_0(1-X)$ = equivalent dielectric constant of plasma
 $-e$ = electron charge
 $\tilde{f}(\gamma, k)$ = transform of $f(r, z) = \int_0^\infty \int_0^\infty f(r, z) e^{-jkz} r J_m(\gamma r) dr dz$
 $f(r, z)$ = inverse transform of $\tilde{f}(\gamma, k) = \frac{1}{2\pi} \int_0^\infty \int_{-\infty}^\infty \tilde{f}(\gamma, k) e^{jkz} J_m(\gamma r) \gamma d\gamma dk$
 \bar{F} = force source
 $F(c)$ = fields due to source c in a warm plasma
 $\langle F(c), S(v) \rangle$ or $\langle F(c), \bar{J}_v + \bar{K}_v + \bar{F}_v + Q_v \rangle = \int_V (\bar{E}_c \cdot \bar{J}_v - \bar{H}_c \cdot \bar{K}_v + \bar{v}_c \cdot \bar{F}_v - P_c Q_v / n_0) dV_v$ = reaction of the v fields due to source c with source v
 $G_{a(d)}$ = real part of $K^2 Y_t$ with (or without) acoustic effects
 $I_{kk} = 2/2k + 1$
 \bar{J} = electric current source
 \bar{K} = magnetic current source
 K = characteristic impedance of spherical transmission line = $(Z_0/\pi) \log(\cot(\theta_0/2))$

$k_o \equiv \omega \sqrt{\mu_o \epsilon_o} =$ free space propagation constant

$k_e = \sqrt{1-X} k_o =$ propagation constant for EM waves in warm plasma
when $\omega > \omega_p$

$k_p \equiv (c/u)k_e \equiv$ propagation constant for acoustic waves in a warm plasma when $\omega > \omega_p$

$k_o \ell =$ free space "phase length"

$k_e \ell =$ electrical "phase length" when $\omega > \omega_p$

$k_p \ell =$ acoustic "phase length" when $\omega > \omega_p$

$\ell =$ dipole half length

$m =$ electron mass

$M_k = R_k'(k_o \ell) / R_k(k_o \ell)$

$n_o =$ average electron density (constant)

$n_1 =$ variation in electron density

$n = n_o + n_1 =$ total electron density

$O_k = S_k'(k_o \ell) / S_k(k_o \ell)$

$P_o =$ average electron pressure (constant)

$P_1 =$ pressure deviation of electrons from the mean

$P = P_o + P_1 \equiv$ total electron pressure

$Q =$ fluid flux source (electron source)

$R_k(x) = (x)^{1/2} H_{k+1/2}^{(2)}(x)$

$R_k'(x) = \frac{d}{dx} R_k(x)$

$\rho = a/\ell =$ ratio of radius to half length for a cylindrical dipole

$R_{a(d)} =$ real part of Z_{in} for a biconical dipole with (or without) acoustic effects

$S(c) = \bar{J}_c + \bar{K}_c + \bar{F}_c + Q_c =$ source c

$S_k(x) = (x)^{1/2} J_{k+1/2}(x)$

$S_k'(x) = \frac{d}{dx} S_k(x)$

μ_0 = free space permeability

u = r.m.s. thermal velocity of electrons \square acoustic velocity in electron gas (constant)

\bar{v} = mean electron velocity

V_k = defined for ease in writing, see page 57

ω_p = plasma frequency, $\omega_p^2 = n_0 e^2 / m \epsilon_0$

$X = \omega_p^2 / \omega^2$

$X_{a(d)}$ \square imaginary part of Z_{in} for a biconical dipole with (or without) acoustic effects

Y_t = terminal admittance of biconical antenna

$Z_0 = \sqrt{\mu_0 / \epsilon_0}$ = free space wave impedance

$Z = \sqrt{\mu_0 / \epsilon}$ = wave impedance for EM waves in warm plasma

Z_{JEM} = portion of Z_{in} due to EM wave generated by \bar{J} in a warm plasma

Z_{JP} = portion of Z_{in} due to acoustic wave generated by \bar{J} in a warm plasma

Z_F = portion of Z_{in} due to acoustic sources in a warm plasma

Z_{in} = input impedance of a dipole in a warm plasma

I. INTRODUCTION

When an antenna is immersed in some medium other than free space, its impedance characteristics and radiation pattern may undergo quite radical changes depending on the characteristics of the media. If the antenna is part of a communication system, its impedance should be matched to the energy source for efficient power transfer. If it is to be used as a probe to study the media, its impedance properties must be well known. The extensive space programs now in progress have led to many investigations of electromagnetic propagation in a plasma medium. In this work the impedance properties of some dipole antennas in a warm plasma will be discussed.

It is a well-known fact, at present, that a warm plasma supports essentially two types of wave motion, that is, transverse "electromagnetic" waves and longitudinal "plasma" or acoustic waves. In this work the impedance properties of a biconical dipole encased in a dielectric and then immersed in a warm plasma is discussed in addition to a cylindrical dipole in intimate contact with a warm plasma.

Whale (1963, 1964) has observed experimentally the excitation of acoustic and EM waves by rocket-borne antennas in the ionosphere. Field (1956) investigated a purely longitudinal (acoustic) wave incident on a plasma-free space interface which excites both EM and acoustic waves. He found that in some cases the EM wave excited in the free space region carries an appreciable amount of power and suggested that this mechanism was responsible for radio emission from solar corona. In a similar work Wait (1966 a) solved the problem

of an acoustic point source in a plasma bubble and found the EM power radiated was at best a small fraction of the original source acoustic power.

Hessel and Shmoys (1962) derived a pair of uncoupled wave equations for the EM and acoustic waves in a warm plasma and indicated there would be coupling between the two only at a discontinuity in the plasma; however, both electric and acoustic sources can, in general, generate both types of waves. For an electric dipole they found the ratio of the power radiated in the acoustic wave to that in the EM wave (P_p/P_e) to be proportional to $(c/u)^3$ where c is the velocity of light and u the velocity of sound in the plasma. However, they obtained quite different results for a prescribed current distribution on a rigid sphere. Chen (1964), on the other hand, found the ratio P_p/P_e to be independent of c/u for a thin wire of finite length with a sinusoidally distributed current with a propagation constant identical to that of EM waves in the plasma. Seshadri (1965) also found P_p/P_e proportional to $(c/u)^3$ for a two-component plasma. Wait (1964) and Wait and Spies (1966) investigated the impedance of an infinitesimal slotted sphere in a warm plasma. He presented values for G (conductance) and ΔB , the change from the free space susceptance, and found acoustic effects to be quite significant in some cases. Fejer (1964) considered a dipole composed of two antiphase excited charged oscillating spheres and obtained results similar to Wait's for acoustically large antennas. Galejs (1966) considered a slotted plane backed by a rectangular waveguide radiating into a stratified warm plasma and derived a variational expression for the slot

admittance. Seshadri (1965b) considered a dipole surrounded by a cylindrical column of insulation and found the power transferred to the acoustic wave to be strongly decreased with increasing sheath thickness. Wait and Spies (1966) and Galejs (1966) observed the same phenomena for increasing ion sheath sizes.

In a series of three papers Cohen (1961, 1962) extended the equivalent source concept to a warm plasma and derived field discontinuities for given source distributions. Cohen (1962) also considered the antenna problem and stated that the acoustic source distribution in addition to the current distribution along the antenna contributes to impedance. Balmain (1965) treated the problem of an electrically short antenna with a triangular current distribution in a warm plasma and considered only the effect of electric sources on impedance. Kuehl (1966) studied the same problem but solved the Boltzmann equation instead of using the simpler hydrodynamic plasma description. An interesting result of his work is the existence of a real part for the impedance for frequencies less than the plasma frequency. Cook and Edgar (1966) found that the current distribution along an antenna in a warm plasma exhibits both EM and acoustical properties. They then considered the contribution of this current distribution to radiation resistance. Seshadri (1965 c) and Wait (1966 b) investigated the infinite cylindrical dipole fed by a delta function source in a warm plasma. Seshadri (1965 d) and Galejs (1965) have investigated the propagation constants for the current distribution along an infinitely long cylinder in a warm plasma and found it to contain terms identifiable with EM and acoustic waves.

It is evident from the references cited above that there has been a great deal of work done on antenna impedance in a warm plasma. However, none of these have treated the effect of acoustic sources on the impedance of a cylindrical dipole. In this work, the effect of acoustic sources on impedance is discussed.

Stationary formulas are one possible approach which have been used to compute antenna impedance. For antennas in free space a stationary formula can be derived for antenna impedance (Harrington 1961) in terms of the induced current on the antenna surface. In this work a similar stationary expression was derived for impedance in a warm plasma in terms of both the induced current and the force distribution on the antenna surface. A convenient characteristic of stationary formulas is their independence of the trial functions magnitude. Because of this, it was possible to assume only the functional form of the current distribution and force distributions, as the relative weighting of their magnitudes is inherent in the stationary formulation of the problem.

The major problem in the variational formulation is guessing the trial functions accurately. For this reason a different antenna model was used to obtain detailed numerical results. The biconical dipole in free space has been investigated extensively by Schelkunoff (1946), Tai (1948, 1949) and Smith (1948). In fact, the thin biconical dipole is one of the few antenna boundary value problems for which an "exact" solution has been obtained. The bicone lends itself to mathematical analysis as the region between the cones is a spherical transmission line for which modal solutions may be derived in terms of well-known functions.

Because of this, one would hope that a similar analysis might be possible for a bicone in a warm plasma. Unfortunately, this is not the case. The main difficulty arises because the propagation constants for "plasma" and "EM" waves are different in the radial direction. However, the analysis is mathematically tractable if one treats a bicone surrounded by a dielectric sphere which insulates the antenna from the plasma. For thin antennas an exact solution was obtained and extensive numerical data is presented. The thick biconical antenna, on the other hand, is solved only approximately by means of a variational formula, but it illustrates quite effectively the effects of an ion sheath or insulating layer on impedance.

II. FORMULATION OF THE IMPEDANCE PROBLEM FOR A
CYLINDRICAL DIPOLE IN A WARM PLASMA

2.1 Basic Equations and a Statement of the Reciprocity Principle for
a Warm Plasma

It is well known at present that an antenna immersed in a warm plasma generates both transverse electromagnetic waves and longitudinal plasma waves. There are essentially four general types of sources which can generate these waves (see Cohen, 1962, part II). They are an electric current source \bar{J} , a magnetic current source \bar{K} , a fluid flux source Q and a mechanical body source \bar{F} , respectively.

If the single component fluid model is used for the plasma with the assumptions that the effects of collisions are negligible, the drift velocity is zero, and $e^{j\omega t}$ time dependence, the basic linearized (low-level r-f fields) equations are as given by Cohen (1962, part II) and are repeated here for convenience:

$$\nabla \times \bar{E} + j\omega \mu_0 \bar{H} = -\bar{K} \quad (2-1)$$

$$\nabla \times \bar{H} - j\omega \epsilon_0 \bar{E} = \bar{J} - n_0 e \bar{v} \quad (2-2)$$

$$j\omega m n_0 \bar{v} + n_0 e \bar{E} + \nabla P_1 = \bar{F} \quad (2-3)$$

$$\nabla \cdot n_0 \bar{v} + j\omega n_1 = Q \quad (2-4)$$

where

m = electron mass

$-e$ = electron charge

\bar{v} = mean electron velocity

n_0 = average electron density (constant)

P_1 = pressure deviation of electrons from the mean

n_1 = variation in electron density

$n = n_0 + n_1$ = total electron density

P_0 = average electron pressure (constant)

$P = P_0 + P_1$ = total pressure

u = rms velocity of electrons = plasma wave velocity (constant)

The adiabatic gas law ($T \propto n^{\gamma-1}$) with $\gamma = 3$ yields a relationship between P and n .

$$P = P_0 + P_1 = \frac{1}{3} n_0 m u^2 + n_1 m u^2 \quad (2-5)$$

where

$$P_1 = n_1 m u^2 \quad (2-6)$$

and

$$P_0 = \frac{1}{3} n_0 m u^2$$

Equations (2-1) and (2-2) are the usual Maxwell equations with an induced source term due to the motion of charge in the plasma.

Equation (2-3) is the equation of motion and (2-4) is the continuity (particle conservation) equation for the electron gas.

On combining equations (2-1) - (2-4) and substituting for n_1 by means of equation (2-6), two separate wave equations can be derived for \bar{H} (EM waves) and P_1 (plasma waves). They are

$$\nabla \times \nabla \times \bar{H} - k_e^2 \bar{H} = -j\omega \epsilon_0 (1-X) \bar{K} + \nabla \times \bar{J} - \frac{\epsilon}{j\omega m} \nabla \times \bar{F} \quad (2-7)$$

$$\nabla^2 P_1 + k_p^2 P_1 = \nabla \cdot \bar{F} + \frac{n_0 e}{j\omega \epsilon_0} \nabla \cdot \bar{J} - j\omega m (1-X) Q \quad (2-8)$$

where $\omega_p^2 = \frac{n_0 e^2}{m \epsilon_0}$ = square of the plasma frequency

$$X = \omega_p^2 / \omega^2$$

$$\epsilon = \epsilon_0 (1 - X)$$

$k_0^2 = \omega^2 \mu_0 \epsilon_0$ = free space propagation constant

$k_e^2 = \frac{\omega^2 - \omega_p^2}{c^2} = \omega^2 \mu_0 \epsilon$ = EM wave propagation constant

$k_p^2 = (c/u)^2 k_e^2$ = plasma wave propagation constant

The remaining field components are derivable from \bar{H} and P_1 by means of Equations (2-1) - (2-4).

A reciprocity principle may be derived for a warm plasma in a manner similar to that used for fields in free space. Consider two different source distributions in the same plasma which give rise to two sets of fields as shown in Figure 1.

$$\begin{pmatrix} \bar{H}_1 \\ \bar{K}_1 \\ Q_1 \\ \bar{V}_1 \end{pmatrix} \rightarrow \begin{pmatrix} \bar{H}_1 \\ P_1 \\ \bar{V}_1 \end{pmatrix} \quad , \quad \begin{pmatrix} \bar{H}_2 \\ \bar{K}_2 \\ Q_2 \\ \bar{V}_2 \end{pmatrix} \rightarrow \begin{pmatrix} \bar{H}_2 \\ P_2 \\ \bar{V}_2 \end{pmatrix}$$

expansion of the vector product $\nabla \cdot (\bar{E}_1 \times \bar{H}_2 - \bar{E}_2 \times \bar{H}_1 + P_1 \bar{V}_2 - P_2 \bar{V}_1)$

yields the following relationship:

$$\begin{aligned} \nabla \cdot (\bar{E}_1 \times \bar{H}_2 - \bar{E}_2 \times \bar{H}_1 + P_1 \bar{V}_2 - P_2 \bar{V}_1) &= -\bar{H}_2 \cdot \bar{K}_1 - \bar{E}_1 \cdot \bar{J}_2 \\ &+ \bar{H}_1 \cdot \bar{K}_2 + \bar{E}_2 \cdot \bar{J}_1 + \frac{P_1 Q_2}{n_0} + \bar{V}_2 \cdot \bar{F}_1 - \frac{P_2 Q_1}{n_0} - \bar{V}_1 \cdot \bar{F}_2 \end{aligned}$$

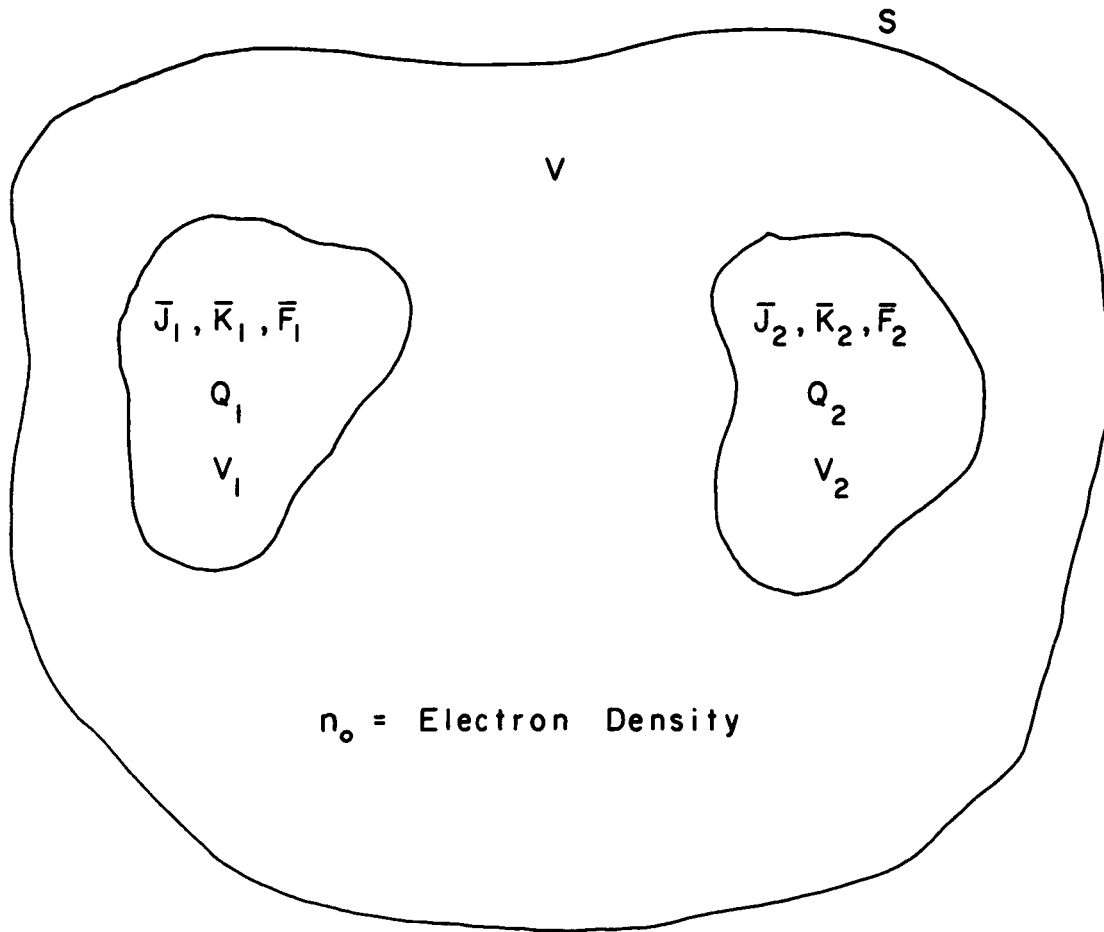

Figure 1. Geometry used in determination of reciprocity principle

Integrating over the volume V and utilizing the divergence theorem yields

$$\iint_S (\bar{E}_1 \times \bar{H}_2 - \bar{E}_2 \times \bar{H}_1 + P_1 \bar{v}_2 - P_2 \bar{v}_1) \cdot d\bar{S} = -\iiint_V (\bar{E}_1 \cdot \bar{J}_2 - \bar{H}_1 \cdot \bar{K}_2 + \bar{v}_1 \cdot \bar{F}_2 - P_1 Q_2 / n_0) dV + \iiint_V (\bar{E}_2 \cdot \bar{J}_1 - \bar{H}_2 \cdot \bar{K}_1 + \bar{v}_2 \cdot \bar{F}_1 - P_2 Q_1 / n_0) dV$$

Letting S tend to infinity and invoking the radiation condition of outgoing waves at infinity yields¹

$$\iint_{S \rightarrow \infty} (\bar{E}_1 \times \bar{H}_2 - \bar{E}_2 \times \bar{H}_1 + P_1 \bar{v}_2 - P_2 \bar{v}_1) \cdot d\bar{S} = 0$$

Thus, the statement of the reciprocity principle in a warm plasma is

$$\iiint_{V_2} (\bar{E}_1 \cdot \bar{J}_2 - \bar{H}_1 \cdot \bar{K}_2 + \bar{v}_1 \cdot \bar{F}_2 - P_1 Q_2 / n_0) dV_2 = \iiint_{V_1} (\bar{E}_2 \cdot \bar{J}_1 - \bar{H}_2 \cdot \bar{K}_1 + \bar{v}_2 \cdot \bar{F}_1 - P_2 Q_1 / n_0) dV_1 \quad (2-9)$$

The volume integrals in the above will be denoted as the reaction of an appropriate field with an appropriate source in analogy with the work of Rumsey (1954). The symbol

$$\langle F(1), S(2) \rangle \equiv \iiint_{V_2} (\bar{E}_1 \cdot \bar{J}_2 - \bar{H}_1 \cdot \bar{K}_2 + \bar{v}_1 \cdot \bar{F}_2 - P_1 Q_2 / n_0) dV_2 \quad (2-10)$$

will be called the reaction of the fields due to source 1 with source

2. Hence, in a warm isotropic plasma the reciprocity principle may be concisely expressed as

$$\langle F(1), S(2) \rangle = \langle F(2), S(1) \rangle \quad (2-11)$$

¹For anisotropic plasmas it is not immediately obvious that this type of radiation condition is correct as the direction of energy flow and wave propagation are not necessarily the same. This phenomenon does not arise in a warm isotropic plasma, however.

2.2 Variational Expression for the Impedance of a General Antenna in a Warm Plasma

The problem geometry is shown in Figure 2a. A current source I_c is connected to two perfect electric conductors immersed in a warm plasma and generates fields \bar{E}_c , \bar{H}_c , P_c and \bar{v}_c . The boundary conditions at the surface of the conductor are assumed to be

$$\hat{n} \times \bar{E}_c = 0, \quad \hat{n} \cdot \bar{v}_c = \alpha P_c \quad (2-12)$$

where α is a constant which depends on the characteristics of the plasma and antenna. The first of these is the usual one for tangential electric fields at the surface of a perfect electric conductor. The second of these was originally postulated by Cohen (1962) as being more realistic than the usual one which requires $\hat{n} \cdot \bar{v} = 0$ at the conductor surface. Wait (1966 c) has also used this "soft wall" boundary condition.

The antenna impedance is the quantity of interest here. The ideal method of determining this would be to solve Equations (2-1) - (2-4) under the constraints of the appropriate boundary conditions (2-12). In general this is impossible to do even for antennas in free space. Hence, one must resort to approximate means for computing the antenna impedance. One possible method of attack here would be to guess the current distribution along the antenna, compute the fields due to this current distribution in the plasma and then use the familiar expression

$$Z_{in} = - \langle F(\bar{J}), \bar{J} \rangle / I_{in}^2 \quad (2-13)$$

to compute the impedance. Note \bar{J} generates both plasma and EM waves.

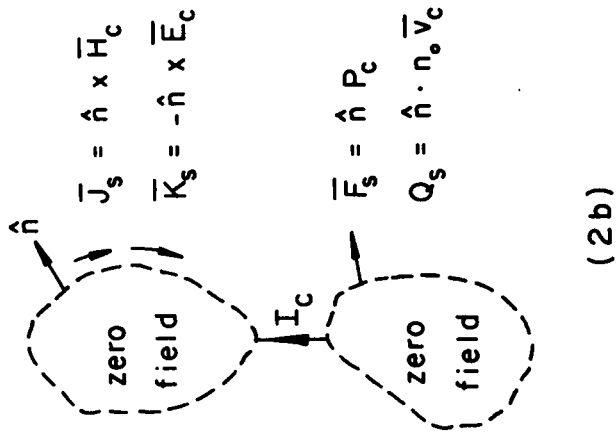
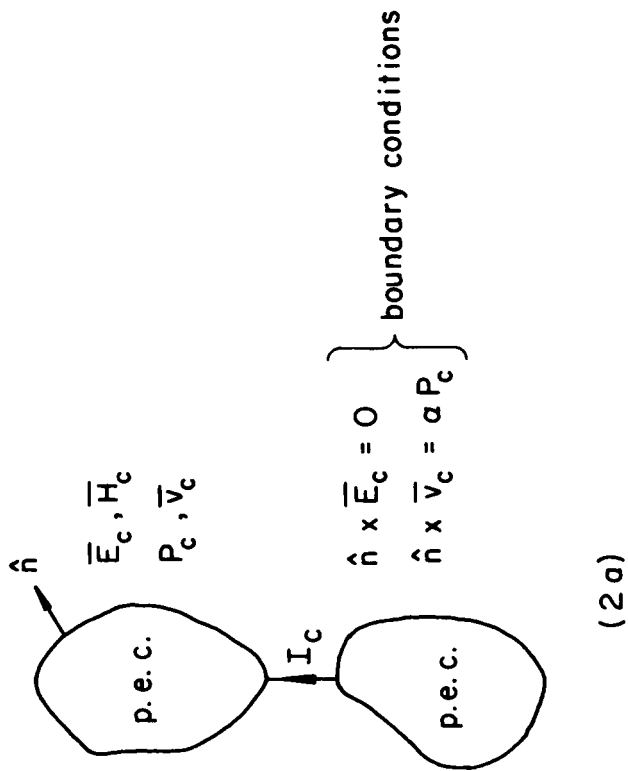

Figure 2. Problem geometry and the equivalent surface source distributions

This method of solution has been used by Kuehl (1966) and Balmain (1965) to compute the impedance of a cylindrical dipole in a warm plasma.

This method, while correct (Jordan, 1950) for antennas in free space, is of questionable validity for antennas in a warm plasma. An antenna immersed in a warm plasma will have not only an induced current in the antenna conductors but also an induced force distribution and fluid flux distribution along the conductors. This was pointed out by Cohen (1962), who also observed that it may not be possible to neglect the effect of these acoustic sources on antenna impedance. The following contains a derivation of an expression which takes into account the effect of these acoustic sources.

For an antenna in free space it is possible to replace the antenna conductors by an equivalent source (the induced current in the antenna) which gives rise to the same fields as the antenna exterior to the antenna conductors and zero fields inside the conductors. For an antenna immersed in a warm plasma this is still possible; however, there will be additional acoustic sources.

Consider Figure 2b. From Cohen's (1962, part II) Equations 4.1 - 4.7, which contain a summary of various sources and the appropriate field discontinuities, it is evident that the surface sources as shown in 2b produce the same fields exterior to the antenna region as the antenna and zero fields in the interior region. This is simply one statement of the equivalence theorem for metal conductors in a warm plasma. Thus, if one could in some way ascertain the values of the equivalent surface source distributions along the antenna surface, it would be relatively simple, in principle, to compute the fields

exterior to the antenna by use of suitable superposition integrals and ultimately determine the antenna impedance.

Consider the reaction of source $S(c)$ with field $F(c)$ where source c is composed of the actual antenna current source I_c and the appropriate equivalent surface sources. From (2-11) this is

$$\langle F(c), S(c) \rangle = \iiint_{V_c} (\bar{E}_c \cdot \bar{J}_s - \bar{H}_c \cdot \bar{K}_s + \bar{v}_c \cdot \bar{F}_s - P_c Q_s / n_o) dV_c$$

where V_c is the volume occupied by I_c and the equivalent sources.

From the boundary conditions as shown in Figure 2a, $\bar{K}_s = 0$ as $\hat{n} \times \bar{E}_c = 0$ on the antenna surface.

$$Q_s = \hat{n} \cdot n_o \bar{v}_c = n_o \alpha P_c \quad \text{as} \quad \hat{n} \cdot \bar{v}_c = \alpha P_c$$

at the antenna surface. Then

$$\iiint_{V_c} \bar{E}_c \cdot \bar{J}_c dV_c = \iiint_{\text{gap}} \bar{E}_c \cdot \bar{I}_c dV_{\text{gap}} = -V_{in} I_{in}$$

where V_{in} and I_{in} are the input current and voltage for the antenna, respectively. The

$$\iiint_{V_c} (\bar{v}_c \cdot \bar{F}_s - P_c Q_s / n_o) dV_c = \iiint_{V_c} (P_c \hat{n} \cdot \bar{v}_c - \frac{P_c}{n_o} \hat{n} \cdot n_o \bar{v}_c) dV_c = 0$$

Hence

$$\langle F(c), S(c) \rangle = -V_{in} I_{in}$$

or alternatively

$$Z_{in} = -\langle F(c), S(c) \rangle / I_{in}^2 \quad (2-14)$$

Note the similarity between (2-14) and (2-13). However, (2-14) also considers the effect of acoustic sources on impedance.

It is a well known fact that expression (2-13) is a variational expression for the input impedance of an antenna in free space. That

is, a first order error in an estimate of the induced current along the antenna results in only a second order error for the impedance (Harrington, 1961). The question here is whether (2-14) has the same characteristic for antennas in a warm plasma.

If trial surface source distributions \bar{J}_s^a , \bar{F}_s^a and Q_s^a are assumed on the antenna surface, the formula for input impedance (Equation (2-14)) is

$$Z_{in} \approx - \langle F(a), S(a) \rangle / I_{in}^2 \quad (2-15)$$

where I_{in} is the input current. Note, because of the boundary condition at the antenna surface

$$\hat{n} \cdot \bar{v} = \alpha P$$

\bar{F}_s^a and Q_s^a are related by the equation

$$\hat{n} \cdot \bar{F}_s^a = P_s^a = \hat{n} \cdot \bar{v}_s^a / \alpha = Q_s^a / \alpha n_0$$

where P_s^a and \bar{v}_s^a are the pressure and velocity fields due to the assumed surface sources \bar{J}_s^a , \bar{F}_s^a and Q_s^a at the antenna surface. The impedance as calculated in (2-15) is stationary about its correct value, as will now be shown. The reaction

$$\langle F(c), S(a) \rangle = \iiint_{V_a} (\bar{E}_c \cdot \bar{J}_s^a - \bar{H}_c \cdot \bar{K}_s^a + \bar{v}_c \cdot \bar{F}_s^a - P_c Q_s^a / n_0) dV_a$$

but at the antenna surface

$$\hat{n} \cdot \bar{v}_c = \alpha P_c, \quad \hat{n} \times \bar{E}_c = 0$$

hence

$$\langle F(c), S(a) \rangle = -V_c I_{in} + \iiint_V (\bar{v}_c \cdot \hat{n} P_s^a - \frac{\hat{n} \cdot \bar{v}_c}{\alpha} \frac{\alpha n_0 P_s^a}{n_0}) dV_a$$

Thus

$$\langle F(c), S(a) \rangle = -V_c I_{in} = -I_{in} Z_{in} = \langle F(c), S(c) \rangle$$

Due to reciprocity $\langle F(c), S(a) \rangle = \langle F(a), S(c) \rangle$. However, it is easy to show that $\langle F(a), S(a) \rangle$ is stationary about the correct value $\langle F(c), S(c) \rangle$ if the constraints

$$\langle F(u), S(a) \rangle = \langle F(c), S(a) \rangle = \langle F(a), S(c) \rangle$$

hold. See Harrington (1961, p.341) for details.

In conclusion, the expression in Equation (2-15) is stationary about the correct value for the antenna impedance when the boundary conditions are as given in (2-12). It is convenient to split the assumed source distribution a into two parts, u (for electromagnetic sources) and v (for acoustic sources). That is, source $a \rightarrow$

$$\begin{pmatrix} \bar{J}_s^a \\ \bar{F}_s^a \\ Q_s^a \end{pmatrix}$$

is composed of u and v where $u \rightarrow U \bar{J}_s^u = \bar{J}_s^a$ and $v \rightarrow \begin{pmatrix} V \bar{F}_s^v = \bar{F}_s^a \\ V Q_s^v = Q_s^a \end{pmatrix}$

Note that \bar{J}_s^u , \bar{F}_s^v and Q_s^v are the functional forms of the appropriate distributions, whereas U and V are unknown constants which are to be determined. The boundary condition $\hat{n} \cdot \bar{v} = \alpha P$ requires that $\hat{n} \cdot \bar{F}_s^v = Q_s^v / \alpha n_0$. The constraints on source a are that

$$\langle F(u), S(a) \rangle = \langle F(c), S(a) \rangle = \langle F(a), S(c) \rangle$$

In terms of the sources u and v this constraint will be satisfied if

$$\langle F(u), S(u) \rangle = \langle F(c), S(u) \rangle$$

$$\langle F(v), S(v) \rangle = \langle F(c), S(v) \rangle$$

Due to the constraints on $\langle F(a), S(a) \rangle$

$$\langle F(a), S(u) \rangle = U \langle F(a), \bar{J}_s^u \rangle = U \langle F(c), \bar{J}_s^u \rangle$$

$$\langle F(a), S(v) \rangle = V \langle F(a), \bar{F}_s^v + Q_s^v \rangle = V \langle F(c), \bar{F}_s^v + Q_s^v \rangle$$

but

$$F(a) = U(F(\bar{J}_s^u)) + V(F(\bar{F}_s^v) + F(Q_s^v))$$

Therefore,

$$U \langle F(\bar{J}_s^u), \bar{J}_s^u \rangle + V \langle F(\bar{F}_s^v) + F(Q_s^v), \bar{J}_s^u \rangle = \langle F(c), \bar{J}_s^u \rangle$$

$$U \langle F(\bar{J}_s^u), \bar{F}_s^v + Q_s^v \rangle + V \langle F(\bar{F}_s^v) + F(Q_s^v), \bar{F}_s^v + Q_s^v \rangle = \langle F(c), \bar{F}_s^v + Q_s^v \rangle$$

In order to simplify the notation, the following definition will be used:

$$\langle u, v \rangle = \langle F(\bar{J}_s^u), \bar{F}_s^v + Q_s^v \rangle$$

with similar definitions for $\langle u, u \rangle$, $\langle v, v \rangle$, and $\langle c, v \rangle$.

The following equations are then obtained for U and V:

$$U \langle u, u \rangle + V \langle v, u \rangle = \langle c, u \rangle$$

$$U \langle u, v \rangle + V \langle v, v \rangle = \langle c, v \rangle$$

where $\langle c, u \rangle$ and $\langle c, v \rangle$ will be determined later.

Thus,

$$\begin{bmatrix} U \\ V \end{bmatrix} = \begin{bmatrix} \langle u, u \rangle & \langle v, u \rangle \\ \langle u, v \rangle & \langle v, v \rangle \end{bmatrix}^{-1} \begin{bmatrix} \langle c, u \rangle \\ \langle c, v \rangle \end{bmatrix}$$

The self reaction

$$\begin{aligned} \langle F(a), S(a) \rangle &= \langle F(c), S(a) \rangle = \langle F(c), U \bar{J}_s^u + V \bar{F}_s^v + V Q_s^v \rangle \\ &= U \langle F(c), \bar{J}_s^u \rangle + V \langle F(c), \bar{F}_s^v + Q_s^v \rangle \\ &= U \langle c, u \rangle + V \langle c, v \rangle \end{aligned}$$

On substituting for U and V it can be shown that

$$\langle F(a), S(a) \rangle = \frac{\langle c, u \rangle^2 \langle v, v \rangle - 2 \langle c, u \rangle \langle c, v \rangle \langle u, v \rangle + \langle c, v \rangle^2 \langle u, u \rangle}{\langle u, u \rangle \langle v, v \rangle - \langle u, v \rangle^2}$$

On applying the boundary conditions at the antenna surface, it can be shown that

$$\langle c, u \rangle = \iiint_{V_u} \bar{E}_c \cdot \bar{J}_s^u dV_u = -V_c I_u$$

$$\begin{aligned} \langle c, v \rangle &= \iiint_{V_v} (\bar{V}_c \cdot \bar{F}_s^v - P_c Q_s^v / n_0) dV_v \\ &= \iiint_{V_v} (\alpha P_c Q_s^v / \alpha n_0 - P_c Q_s^v / n_0) dV_v = 0 \end{aligned}$$

Therefore,

$$\langle F(a), S(a) \rangle = V_c^2 I_u^2 \langle v, v \rangle / (\langle u, u \rangle \langle v, v \rangle - \langle u, v \rangle^2)$$

or

$$-Z_{in} I_{in}^2 = \frac{Z_{in}^2 I_{in}^2 I_u^2 \langle v, v \rangle}{\langle u, u \rangle \langle v, v \rangle - \langle u, v \rangle^2}$$

solving for Z_{in}

$$Z_{in} = -\frac{\langle u, u \rangle}{I_u^2} + \frac{\langle u, v \rangle^2}{I_u^2 \langle v, v \rangle}$$

On substituting for $\langle u, u \rangle$, $\langle u, v \rangle$ and $\langle v, v \rangle$ it can be shown that

$$Z_{in} = -\frac{\langle F(\bar{J}_s^u), \bar{J}_s^u \rangle}{I_u^2} + \frac{\langle F(\bar{J}_s^u), \bar{F}_s^v + Q_s^v \rangle^2}{I_u^2 \langle F(\bar{F}_s^v) + F(Q_s^v), \bar{F}_s^v + Q_s^v \rangle} \quad (2-16)$$

This is similar to Balmain's (1965) expression for input impedance.

In fact, the first term in (2-16) is the expression he used for

impedance. The second term in (2-16) is the correction due to the acoustic sources. All one has to do now is guess the functional form of the sources as the relative magnitudes U and V have been determined, solve for the fields due to these sources in an infinite homogeneous plasma and substitute into (2-16) to determine the impedance. Note that (2-16) is independent of the source function's magnitude as expected.

In the next section these computations were carried out. In order to simplify the computations, it was assumed that $\hat{n} \cdot \bar{v} = 0$ at the antenna surface. This means that $Q_s^V = 0$. Hence, (2-16) simplifies and yields the following expression for input impedance on taking limits in the usual way as $\alpha \rightarrow 0$. Alternatively, one could rederive an impedance expression by simply assuming $\hat{n} \cdot \bar{v} = 0$ initially. This is much simpler and yields the same result as the limiting case, $\alpha \rightarrow 0$.

$$Z_{in} = - \frac{\langle F(\bar{J}_s^u), \bar{J}_s^u \rangle}{I_u^2} + \frac{\langle F(\bar{J}_s^u), \bar{F}_s^v \rangle^2}{I_u^2 \langle F(\bar{F}_s^v), \bar{F}_s^v \rangle} \quad (2-17)$$

2.3 Transform Solution of the Wave Equations and a Formula for the Impedance of a Short Dipole

Equation (2-17) is a variational expression for the impedance of a cylindrical dipole in warm plasma. The antenna surface is assumed to be rigid for acoustic waves (i.e., $\hat{n} \cdot \bar{v} = 0$ at the antenna surface). For electrically short antennas it appears to be reasonable to assume a symmetric triangular current distribution along the

antenna surface. However, to the best of this author's knowledge, there has been no work done on determining the force distribution along conductor surfaces. In fact, one no longer has any intuitive feelings as to the general shape it should assume. Obviously, due to symmetry it will be an asymmetric function about the center of the antenna for a cylindrical dipole. Moreover, one must have a good estimate as to what the actual force distribution is in order to ensure that the expression for antenna impedance (2-17) yields accurate results.

However, in order to obtain the actual current and force distributions along the antenna surface, a pair of coupled integral equations must be solved (see Cohen, 1962, part III). This is a formidable task in its own right and will not be pursued any further here. In this work a relatively simple trial function will be assumed for both the current and force distribution along the antenna surface as shown in Figure 3. Even though this may not yield an "extremely accurate" value for the impedance, it should yield information about the relative effects of the electromagnetic sources and acoustic sources on impedance.

The problem geometry and the assumed form of \bar{J}_s^u and \bar{F}_s^v are shown in Figure 3 where $\delta(r-a)$ is the Dirac delta function and $r(z+l)$ is a unit ramp. Due to symmetry the fields induced by these sources will be functions of r and z alone and \bar{H} will have a component only in the θ direction. Rewriting equations (2-7) and (2-8) yields the following wave equations for EM and plasma waves, respectively,

$$\nabla_x \nabla_x \bar{H} - k_e^2 \bar{H} = \nabla_x \bar{J}_s^u - \frac{e}{j\omega m} \nabla_x \bar{F}_s^v \quad (2-18)$$

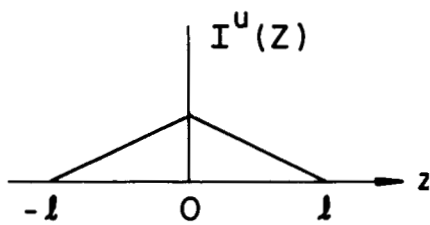
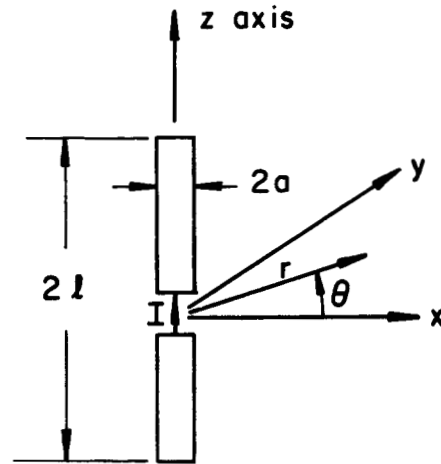

$$\bar{J}_s^u = \frac{I}{2\pi a} \delta(r-a) \left(1 - \frac{|z|}{l}\right)$$

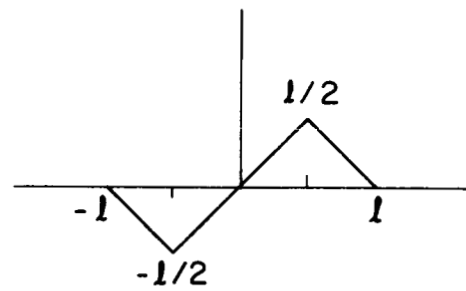

$$\bar{F}_s^v = \delta(r-a) \left[-r(Z+l) + 2r(Z+l/2) - 2r(Z-l/2) + r(Z-l) \right]$$

Figure 3. Problem geometry and the assumed current and force distributions

$$\nabla^2 P_i + k_p^2 P_i = \nabla \cdot \bar{F}_s^V + \frac{n_0 e}{j\omega \epsilon_0} \nabla \cdot \bar{J}_s^u \quad (2-19)$$

In computing the reactions

$$\langle F(\bar{J}_s^u), \bar{J}_s^u \rangle, \langle F(\bar{J}_s^u), \bar{F}_s^V \rangle, \langle F(\bar{F}_s^V), \bar{F}_s^V \rangle$$

it will be necessary to know only the values of E_z and v_r at the antenna surface ($r = a$). These can be easily determined from Equations (2-1) - (2-4) and are

$$E_z = (1/j\omega \epsilon r) \frac{\partial}{\partial r} (r H_\theta) + (e/\omega^2 m \epsilon) \frac{\partial P_i}{\partial z} \quad (2-20)$$

$$v_r = (-e/\omega^2 m \epsilon) \frac{\partial}{\partial z} (H_\theta) - (e_0/j\omega m n_0 e) \frac{\partial P_i}{\partial r} \quad (2-21)$$

Equations (2-18) and (2-19) can be solved by a suitable use of the Fourier and Hankel transforms. The transform pair which will be used is

$$\tilde{f}(r, k) = \int_{-\rho}^{\rho} \int_0^{\rho} f(r, z) e^{-jkz} r J_m(rr) dr dz \quad (2-22)$$

$$f(r, z) = \frac{1}{2\pi} \int_0^{\rho} \int_{-\rho}^{\rho} \tilde{f}(r, k) e^{jkz} J_m(rr) r dr dk \quad (2-23)$$

Essentially there are four distinct types of fields generated by the two assumed source distributions. They are:

- 1) an EM wave due to \bar{J}_s^u
- 2) an EM wave due to \bar{F}_s^V
- 3) a plasma (or acoustic) wave due to \bar{J}_s^u
- 4) a plasma wave due to \bar{F}_s^V

The contributions of these fields to the total antenna impedance will be denoted by ZJEM, ZJP, for 1) and 3), respectively, and ZF for the contribution due to 2) and 4).

Previous authors have considered only the effects of 1) and 3) on antenna impedance. The EM wave generated by \bar{J}_s^u contributes essentially only an imaginary part to the total impedance as the antenna is assumed to be electrically short. An expression for this is derived in Schelkunoff and Friis. It is

$$Z_{JEM} = \frac{1}{j\omega\pi\epsilon l} [\ln(l/a) - 1] \quad (2-24)$$

Consider the plasma wave due to \bar{J}_s^u . It satisfies the following wave equation

$$\nabla^2 P_1 + k_p^2 P_1 = (n_0 e / j\omega\epsilon_0) \nabla \cdot \bar{J}_s^u$$

Using the transform pair (2-22) and (2-23) with $m = 0$ to transform this equation gives

$$(k^2 + \gamma^2 - k_p^2) \hat{\hat{P}}_1 = \frac{n_0 e J_0(ka)}{j\omega 2\pi \epsilon_0 l jk} [Z - e^{-jkl} - e^{jkl}] \quad (2-25)$$

From Equation (2-20)

$$E_z = (e / \omega^2 m \epsilon) \frac{d}{dz} P_1$$

and therefore

$$\hat{\hat{E}}_z = (e / \omega^2 m \epsilon) (jk) \hat{\hat{P}}_1 \quad (2-26)$$

On solving (2-25) for $\hat{\hat{P}}_1$, substituting this result into (2-26) and

taking the inverse transform, the following expression is obtained

for E_z at $r = a$

$$E_z(a, z) = \frac{\chi}{(1-\chi)j\omega\epsilon_0 l (2\pi)^2} \int_{-\rho}^{\rho} \int_0^{\rho} \frac{e^{jkz} r J_0^2(r a)}{(k^2 + r^2 - k_p^2)} \cdot [z - e^{-jkl} - e^{jkl}] d r d k \quad (2-27)$$

The reaction of this field with \bar{J}_s^u is needed for the determination of ZJP. It will be denoted by $\langle u, u \rangle_p$

$$\langle u, u \rangle_p = \iiint_V E_z \cdot \bar{J}_s^u dV = \frac{z}{l} \int_0^l (l-z) E_z(a, z) dz \quad (2-28)$$

For the present, assume $\omega < \omega_p$ and then define $k_p^2 = -\alpha_p^2$ where α_p^2 is now > 0 . Then if it is assumed $\text{Re} \sqrt{r^2 + k_p^2} > 0$, the k integration in Equation (2-27) may be easily performed by using the calculus of residues yielding for $z > 0$.

$$E_z(a, z) = \frac{\chi}{(1-\chi)j\omega\epsilon_0 l (2\pi)^2} \int_0^{\rho} r J_0^2(r a) \pi \cdot \left(\frac{z e^{-\sqrt{r^2 + \alpha_p^2} z}}{\sqrt{r^2 + \alpha_p^2}} - \frac{e^{-\sqrt{r^2 + \alpha_p^2} (z+l)}}{\sqrt{r^2 + \alpha_p^2}} - \frac{e^{-\sqrt{r^2 + \alpha_p^2} |z-l|}}{\sqrt{r^2 + \alpha_p^2}} \right) d r \quad (2-29)$$

On substituting (2-29) into (2-28) and performing the z integration, the following expression results for $\langle u, u \rangle_p$.

$$\langle u, u \rangle_p = - \frac{z}{l} \frac{\chi}{(1-\chi)j\omega\epsilon_0 l 4\pi} \int_0^{\rho} \frac{r J_0^2(r a)}{\sqrt{r^2 + \alpha_p^2}^3} [e^{-\sqrt{r^2 + \alpha_p^2} z l}$$

$$-4e^{-\sqrt{r^2 + \alpha_p^2}} l + 3 - 2l \sqrt{r^2 + \alpha_p^2}] dr$$

But

$$\begin{aligned} ZJP = - \frac{\langle u, u \rangle_p}{I_u^2} &= \frac{Z}{l} \frac{X}{(1-X)j\omega\epsilon_0 l 4\pi} \int_0^a \frac{r^2 J_0^2(r/a)}{\sqrt{r^2 + \alpha_p^2}^{1/3}} \\ & [e^{-\sqrt{r^2 + \alpha_p^2}} 2l - 4e^{-\sqrt{r^2 + \alpha_p^2}} l + 3 - 2l \sqrt{r^2 + \alpha_p^2}] dr \end{aligned} \quad (2-30)$$

The other reactions needed may be computed in a similar manner and expressed as integrals only over the transform variable γ also and hence, only the final results are given here. The only modification necessary is letting $k_e^2 = -\alpha_e^2$ for $\omega < \omega_p$ and in transforming Equation (2-18)

$$\nabla_x \nabla_x \bar{H} - k_e^2 \bar{H} = \nabla_x \bar{J}_s^u - (e/j\omega m) \nabla_x \bar{F}_s^v$$

Here in using the transform pair (2-22) and (2-23), one must set $m = 1$, which yields $(k^2 + \gamma^2 - k_e^2) \tilde{H}_\theta$ for the left hand side of the above equation. The following expressions are then obtained for the necessary reactions

$$\begin{aligned} \langle F(\bar{J}_s^u), \bar{F}_s^v \rangle &= \iiint_V \bar{v}_r \cdot \bar{F} dV = \frac{j\epsilon a}{\omega^2 m \epsilon l} \left\{ \int_0^a \frac{r^2 J_0(r/a) J_1(r/a)}{\sqrt{r^2 + \alpha_e^2}^{1/4}} \right. \\ & [e^{-\sqrt{r^2 + \alpha_e^2}} 2l - 2e^{-\sqrt{r^2 + \alpha_e^2}} 3l/2 + 2e^{-\sqrt{r^2 + \alpha_e^2}} l/2 - 1] dr \\ & - \int_0^a \frac{r^2 J_0(r/a) J_1(r/a)}{\sqrt{r^2 + \alpha_p^2}^{1/4}} [e^{-\sqrt{r^2 + \alpha_p^2}} 2l - 2e^{-\sqrt{r^2 + \alpha_p^2}} 3l/2 \\ & \left. + 2e^{-\sqrt{r^2 + \alpha_p^2}} l/2 - 1] dr \right\} \end{aligned} \quad (2-31)$$

$$\begin{aligned}
\langle F(\bar{F}_s^V), \bar{F}_s^V \rangle &= \iiint_V \bar{v}_r \cdot \bar{F} dV = \frac{2\pi e^2 a^2}{j\omega^3 m^2 \epsilon} \int_0^{\rho} \frac{\gamma J_1^2(\gamma a)}{\sqrt{\gamma^2 + \alpha_e^2}^3} \\
&\left[-e^{-\sqrt{\gamma^2 + \alpha_e^2} 2l} + 4e^{-\sqrt{\gamma^2 + \alpha_e^2} 3l/2} - 4e^{-\sqrt{\gamma^2 + \alpha_e^2} l} \right. \\
&- 4e^{-\sqrt{\gamma^2 + \alpha_e^2} l/2} + 5 - 2l \sqrt{\gamma^2 + \alpha_e^2} \left. \right] d\gamma \\
&+ 2\pi \left(\frac{-\epsilon_0 a^2}{j\omega m n_0 \epsilon} \right) \int_0^{\rho} \frac{\gamma^3 J_1^2(\gamma a)}{\sqrt{\gamma^2 + \alpha_p^2}^5} \left[-e^{-\sqrt{\gamma^2 + \alpha_p^2} 2l} \right. \\
&+ 4e^{-\sqrt{\gamma^2 + \alpha_p^2} 3l/2} - 4e^{-\sqrt{\gamma^2 + \alpha_p^2} l} - 4e^{-\sqrt{\gamma^2 + \alpha_p^2} l/2} \\
&\left. + 5 - 2l \sqrt{\gamma^2 + \alpha_p^2} \right] d\gamma
\end{aligned} \tag{2-32}$$

where the first term in (2-32) is due to the EM waves generated by \bar{F}_s^V and the second term represents the plasma wave contribution. On substituting γ for γa and letting $\rho = a/l$ in Equations (2-30) - (2-32), the following expressions are obtained for $\omega < \omega_p$

$$Z_{in} = Z_{JEM} + Z_{JP} + Z_F \tag{2-33}$$

where

$$Z_{JEM} = \frac{j Z_0}{\pi k_0 l (X-1)} \left[\ln(1/\rho) - 1 \right] \tag{2-34}$$

$$ZJP = \frac{jXpZ_0}{2\pi(x-1)k_0l} \int_0^{\rho} \frac{y J_0^2(y)}{\sqrt{y^2 + (\alpha_p a)^2}} \left[e^{-\sqrt{y^2 + (\alpha_p a)^2} 2/p} - 4e^{-\sqrt{y^2 + (\alpha_p a)^2} 1/p} + 3 - 2\sqrt{y^2 + (\alpha_p a)^2} 1/p \right] dy \quad (2-35)$$

$$ZF = -\frac{jXZ_0p}{2\pi(x-1)^2 k_0l} \left\{ \int_0^{\rho} \frac{y^2 J_0(y) J_1(y)}{\sqrt{y^2 + (\alpha_e a)^2}} \left[e^{-\sqrt{y^2 + (\alpha_e a)^2} 2/p} - 2e^{-\sqrt{y^2 + (\alpha_e a)^2} 3/2p} + 2e^{-\sqrt{y^2 + (\alpha_e a)^2} 1/2p} - 1 \right] dy \right. \\ \left. - \int_0^{\rho} \frac{y^2 J_0(y) J_1(y)}{\sqrt{y^2 + (\alpha_p a)^2}} \left[e^{-\sqrt{y^2 + (\alpha_p a)^2} 2/p} - 2e^{-\sqrt{y^2 + (\alpha_p a)^2} 3/2p} + 2e^{-\sqrt{y^2 + (\alpha_p a)^2} 1/2p} - 1 \right] dy \right\} \\ \left\{ \frac{x}{1-x} \int_0^{\rho} \frac{y J_1^2(y)}{\sqrt{y^2 + (\alpha_e a)^2}} \left[-e^{-\sqrt{y^2 + (\alpha_e a)^2} 2/p} + 4e^{-\sqrt{y^2 + (\alpha_e a)^2} 3/2p} - 4e^{-\sqrt{y^2 + (\alpha_e a)^2} 1/p} - 4e^{-\sqrt{y^2 + (\alpha_e a)^2} 1/2p} + 5 - 2\sqrt{y^2 + (\alpha_e a)^2} 1/p \right] dy \right. \\ \left. - \frac{1}{1-x} \int_0^{\rho} \frac{y^3 J_1^2(y)}{\sqrt{y^2 + (\alpha_p a)^2}} \left[-e^{-\sqrt{y^2 + (\alpha_p a)^2} 2/p} + 4e^{-\sqrt{y^2 + (\alpha_p a)^2} 3/2p} - 4e^{-\sqrt{y^2 + (\alpha_p a)^2} 1/p} - 4e^{-\sqrt{y^2 + (\alpha_p a)^2} 1/2p} + 5 - 2\sqrt{y^2 + (\alpha_p a)^2} 1/p \right] dy \right\}$$

where

$$Z_0 = \sqrt{\mu_0/\epsilon_0} = \text{wave impedance of free space}$$

$$k_0 l = \text{free space "phase length" of antenna}$$

$$\alpha_e l = \sqrt{X-1} k_0 l = \text{electrical "phase length" of antenna}$$

$$\alpha_p l = (c/u) \alpha_e l = \text{acoustical "phase length" of antenna}$$

Note that all the impedances are reactive in this case, as relatively little radiation takes place for $\omega < \omega_p$. The integral expressions in (2-35) and (2-36) are both free of poles along the positive real axis and converge to zero properly as y tends to infinity and hence are relatively easy to integrate numerically on a digital computer.

When $\omega > \omega_p$ the expressions for the necessary reactions are the same as those given in Equations (2-30) - (2-32) if k_e^2 and k_p^2 are substituted for $-\alpha_e^2$ and $-\alpha_p^2$. That is,

$$Z_{JP} = \frac{2X}{l(1-X)j\omega\epsilon_0 l 4\pi} \int_0^l \frac{r J_0^2(r a)}{\sqrt{r^2 - k_p^2}^3} \left\{ e^{-\sqrt{r^2 - k_p^2} 2l} - 4e^{-\sqrt{r^2 - k_p^2} l} + 3 - 2l\sqrt{r^2 - k_p^2} \right\} dr \quad (2-37)$$

$$\langle F(\bar{J}_s^u), \bar{F}_s^v \rangle = \frac{j\epsilon a}{\omega^2 m \epsilon l} \left\{ \int_0^l \frac{r^2 J_0(r a) J_1(r a)}{\sqrt{r^2 - k_e^2}^4} \left[e^{-\sqrt{r^2 - k_e^2} 2l} - 2e^{-\sqrt{r^2 - k_e^2} 3l/2} + 2e^{-\sqrt{r^2 - k_e^2} l/2} - 1 \right] dr \right. \\ \left. - \int_0^l \frac{r^2 J_0(r a) J_1(r a)}{\sqrt{r^2 - k_p^2}^4} \left[e^{-\sqrt{r^2 - k_p^2} 2l} - 2e^{-\sqrt{r^2 - k_p^2} 3l/2} + 2e^{-\sqrt{r^2 - k_p^2} l/2} - 1 \right] dr \right\} \quad (2-38)$$

$$\begin{aligned}
\langle F(\bar{F}_s^V), \bar{F}_s^V \rangle &= \frac{2\pi e^2 a^2}{j\omega^3 m^2 \epsilon} \int_0^{\rho} \frac{\gamma J_1^2(\gamma a)}{\sqrt{\gamma^2 - k_e^2}^3} \left[-e^{-\sqrt{\gamma^2 - k_e^2} 2l} \right. \\
&+ 4 e^{-\sqrt{\gamma^2 - k_e^2} 3l/2} - 4 e^{-\sqrt{\gamma^2 - k_e^2} l} - 4 e^{-\sqrt{\gamma^2 - k_e^2} l/2} + 5 \\
&\left. - 2l \sqrt{\gamma^2 - k_e^2} \right] d\gamma + 2\pi \left(\frac{-\epsilon_0 a^2}{j\omega m n_0 \epsilon} \right) \int_0^{\rho} \frac{\gamma^3 J_1^2(\gamma a)}{\sqrt{\gamma^2 - k_p^2}^5} \\
&\left[-e^{-\sqrt{\gamma^2 - k_p^2} 2l} + 4 e^{-\sqrt{\gamma^2 - k_p^2} 3l/2} - 4 e^{-\sqrt{\gamma^2 - k_p^2} l} \right. \\
&\left. - 4 e^{-\sqrt{\gamma^2 - k_p^2} l/2} + 5 - 2l \sqrt{\gamma^2 - k_p^2} \right] d\gamma
\end{aligned}$$

(2-39)

Here a small amount of loss has been introduced (k_e and k_p are slightly complex) and that branch of the square root is chosen which makes

$$\operatorname{Re} \sqrt{\gamma^2 - k_e^2} > 0, \quad \operatorname{Re} \sqrt{\gamma^2 - k_p^2} > 0 \quad (2-40)$$

The loss is essentially due to the introduction of collisions in the force equation (2-3). The relative magnitude of this effect depends on the ratio of the collision frequency ν to the forcing frequency ω . It can easily be shown that collisions shift k_p and k_e off the positive real axis into the lower half of the γ plane as shown in Figure 4. In the ionosphere the ν/ω ratio is usually $\ll 1$ and hence, this effect will be neglected in (2-37) - (2-39), but it indicates how the contour of integration must be indented as shown in Figure 4, and also the

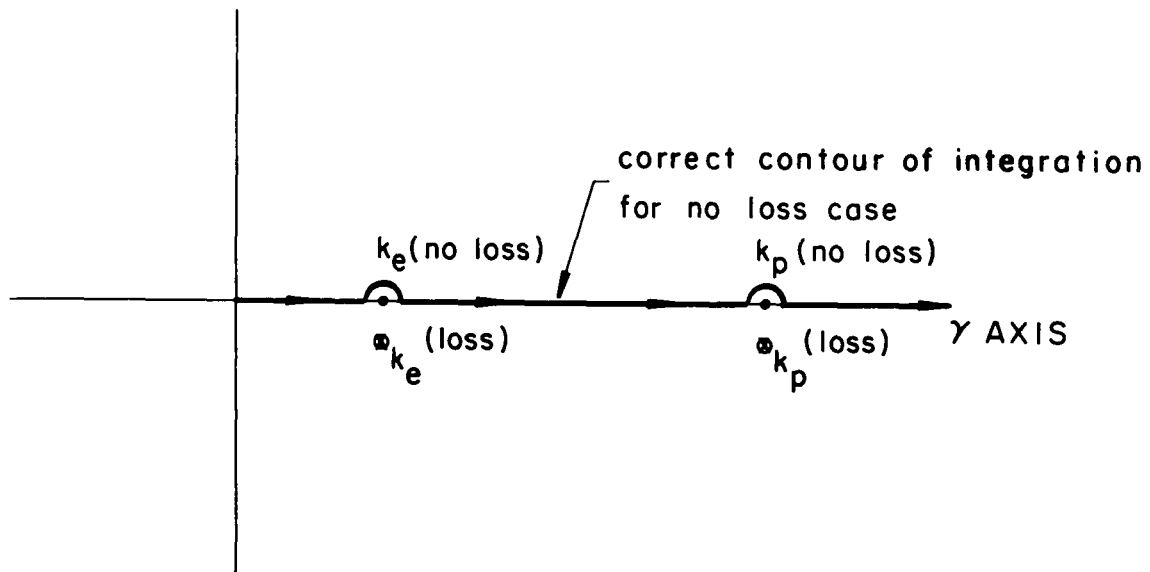

Figure 4. Contour of integration used in determining inverse Hankel transform

proper branch to choose for the square roots $\sqrt{\gamma^2 - k_p^2}$, and $\sqrt{\gamma^2 - k_e^2}$.

On consideration of the constraints on the above square roots in the lossy case in conjunction with Figure 4, it can be shown that in the no-loss case the square roots are for

$$\gamma < k_{e,p} \quad , \quad \sqrt{\gamma^2 - (k_{e,p})^2} = j \sqrt{(k_{e,p})^2 - \gamma^2}$$

$$\gamma > k_{e,p} \quad , \quad \sqrt{\gamma^2 - (k_{e,p})^2} = \sqrt{\gamma^2 - (k_{e,p})^2}$$

where the positive value is taken for the square roots on the far right in the above. Consider the integrand in Equation (2-37)

$$\frac{\gamma J_0^2(\gamma a)}{\sqrt{\gamma^2 - k_p^2}^3} \left[e^{-\sqrt{\gamma^2 - k_p^2} z l} - 4 e^{-\sqrt{\gamma^2 - k_p^2} l} + 3 - 2 l \sqrt{\gamma^2 - k_p^2} \right]$$

On expanding the bracketed term in a power series, it can be shown that this function is well behaved at $\gamma = k_p$ and hence, its integration from 0 to ∞ presents no problem. A similar argument shows that the integrand in Equation (2-38), which is of the form

$$\frac{\gamma^2 J_0(\gamma a) J_1(\gamma a)}{\sqrt{\gamma^2 - (k_{e,p})^2}^4} \left[e^{-\sqrt{\gamma^2 - (k_{e,p})^2} z l} - 2 e^{-\sqrt{\gamma^2 - (k_{e,p})^2} 3l/2} + 2 e^{-\sqrt{\gamma^2 - (k_{e,p})^2} l/2} - 1 \right]$$

has a singularity of the form $1/\sqrt{\gamma - k_{e,p}}$ at $k_{e,p}$. However, this singularity is integrable and once again the integral from 0 to ∞ presents no problem. The first integrand in (2-39)

$$\frac{\gamma J_1^2(\gamma a)}{\sqrt{\gamma^2 - k_e^2}^3} \left[-e^{-\sqrt{\gamma^2 - k_e^2} 2l} + 4e^{-\sqrt{\gamma^2 - k_e^2} 3l/2} \right. \\ \left. - 4e^{-\sqrt{\gamma^2 - k_e^2} l} - 4e^{-\sqrt{\gamma^2 - k_e^2} l/2} + 5 - 2l\sqrt{\gamma^2 - k_e^2} \right]$$

is well behaved at $\gamma = k_e$ and its integration presents no problem.

For the second term,

$$\frac{\gamma^3 J_1^2(\gamma a)}{\sqrt{\gamma^2 - k_p^2}^5} \left[-e^{-\sqrt{\gamma^2 - k_p^2} 2l} + 4e^{-\sqrt{\gamma^2 - k_p^2} 3l/2} \right. \\ \left. - 4e^{-\sqrt{\gamma^2 - k_p^2} l} - 4e^{-\sqrt{\gamma^2 - k_p^2} l/2} + 5 - 2l\sqrt{\gamma^2 - k_p^2} \right]$$

$$\equiv \frac{f(\gamma)}{\gamma - k_p}$$

it is a different story. It has a pole of the form $1/(\gamma - k_p)$ at $\gamma = k_p$ and its contribution must be taken into account. In fact, it was found that just taking the principal value of $\int_0^\infty \frac{f(\gamma)}{\gamma - k_p} d\gamma$ yields results which are physically meaningless (e.g., the real part of ZF was found to be negative in some cases). The correct way to evaluate

the $\int_0^\infty \frac{f(\gamma)}{\gamma - k_p} d\gamma$ is

$$\int_0^\infty \frac{f(\gamma)}{\gamma - k_p} d\gamma = \text{P.V.} \int_0^\infty \frac{f(\gamma)}{\gamma - k_p} d\gamma - j\pi f(k_p) \quad (2-41)$$

where the second term is the pole contribution and the direction of integration around the pole is as shown in Figure 4. There was no

problem in this case with physically inconsistent results and the principal value integral is relatively easy to do numerically on a digital computer.

After utilization of Equations (2-37) - (2-41) and some algebraic simplification, the following impedance expressions were obtained for the case $\omega > \omega_p$

$$Z_{in} = Z_{JEM} + Z_{JIP} + Z_F \quad (2-42)$$

$$Z_{JEM} = \frac{-j Z_0 \rho}{\pi k_0 \lambda (1-X)} \left[\ln(1/\rho) - 1 \right] \quad (2-43)$$

$$\begin{aligned} Z_{JIP} = & \frac{X Z_0 \rho}{(1-X) k_0 \lambda 2\pi} \left\{ \int_0^{k_p a} \frac{y J_0^2(y)}{\sqrt{(k_p a)^2 - y^2}^3} \left[\cos(\sqrt{(k_p a)^2 - y^2} z/\rho) \right. \right. \\ & \left. \left. - 4 \cos(\sqrt{(k_p a)^2 - y^2} 1/\rho) + 3 \right] dy - j \int_0^{k_p a} \frac{y J_0^2(y)}{\sqrt{(k_p a)^2 - y^2}^3} \cdot \right. \\ & \left. \left[\sin(\sqrt{(k_p a)^2 - y^2} z/\rho) - 4 \sin(\sqrt{(k_p a)^2 - y^2} 1/\rho) + 2\sqrt{(k_p a)^2 - y^2} 1/\rho \right] dy \right. \\ & \left. - j \int_{k_p a}^{\rho} \frac{y J_0^2(y)}{\sqrt{y^2 - (k_p a)^2}^3} \left[e^{-\sqrt{y^2 - (k_p a)^2} z/\rho} \right. \right. \\ & \left. \left. - 4 e^{-\sqrt{y^2 - (k_p a)^2} 1/\rho} + 3 - 2\sqrt{y^2 - (k_p a)^2} 1/\rho \right] dy \right. \end{aligned}$$

(2-44)

$$ZF = - \frac{jX Z_0 P}{2\pi(1-X)^2 k_0 l} \frac{(NUM)^2}{(DEN)} \quad (2-45)$$

$$\begin{aligned}
 NUM = & \int_0^{k_e a} \frac{y^2 J_0(y) J_1(y)}{\sqrt{(k_e a)^2 - y^2}^4} \left[\cos(\sqrt{(k_e a)^2 - y^2} z/p) \right. \\
 & - 2 \cos(\sqrt{(k_e a)^2 - y^2} 3/2p) + 2 \cos(\sqrt{(k_e a)^2 - y^2} 1/2p) - 1 \left. \right] dy \\
 & + \int_{k_e a}^{\infty} \frac{y^2 J_0(y) J_1(y)}{\sqrt{y^2 - (k_e a)^2}^4} \left[e^{-\sqrt{y^2 - (k_e a)^2} z/p} - 2 e^{-\sqrt{y^2 - (k_e a)^2} 3/2p} \right. \\
 & \left. + 2 e^{-\sqrt{y^2 - (k_e a)^2} 1/2p} - 1 \right] dy - \int_0^{k_p a} \frac{y^2 J_0(y) J_1(y)}{\sqrt{(k_p a)^2 - y^2}^4} \cdot \\
 & \left[\cos(\sqrt{(k_p a)^2 - y^2} z/p) - 2 \cos(\sqrt{(k_p a)^2 - y^2} 3/2p) \right. \\
 & \left. + 2 \cos(\sqrt{(k_p a)^2 - y^2} 1/2p) - 1 \right] dy - \int_{k_p a}^{\infty} \frac{y^2 J_0(y) J_1(y)}{\sqrt{y^2 - (k_p a)^2}^4} \cdot \\
 & \left[e^{-\sqrt{y^2 - (k_p a)^2} z/p} - 2 e^{-\sqrt{y^2 - (k_p a)^2} 3/2p} + 2 e^{-\sqrt{y^2 - (k_p a)^2} 1/2p} \right. \\
 & \left. - 1 \right] dy + j \int_0^{k_e a} \frac{y^2 J_0(y) J_1(y)}{\sqrt{(k_e a)^2 - y^2}^4} \cdot \left[-\sin(\sqrt{(k_e a)^2 - y^2} z/p) \right. \\
 & \left. + 2 \sin(\sqrt{(k_e a)^2 - y^2} 3/2p) - 2 \sin(\sqrt{(k_e a)^2 - y^2} 1/2p) \right] dy
 \end{aligned}$$

$$-j \int_0^{k_p a} \frac{y^2 J_0(y) J_1(y)}{\sqrt{(k_p a)^2 - y^2}^4} \left[-\sin(\sqrt{(k_p a)^2 - y^2} \cdot 2/\rho) + 2\sin(\sqrt{(k_p a)^2 - y^2} \cdot 3/2\rho) \right.$$

$$\left. - 2\sin(\sqrt{(k_p a)^2 - y^2} \cdot 1/2\rho) \right] dy \quad (2-46)$$

$$DEN = \frac{X}{1-X} \int_0^{k_e a} \frac{y J_1^2(y)}{\sqrt{(k_e a)^2 - y^2}^3} \left[-\sin(\sqrt{(k_e a)^2 - y^2} \cdot 2/\rho) \right.$$

$$+ 4\sin(\sqrt{(k_e a)^2 - y^2} \cdot 3/2\rho) - 4\sin(\sqrt{(k_e a)^2 - y^2} \cdot 1/\rho)$$

$$\left. - 4\sin(\sqrt{(k_e a)^2 - y^2} \cdot 1/2\rho) + 2(\sqrt{(k_e a)^2 - y^2} \cdot 1/\rho) \right] dy$$

$$+ \frac{X}{1-X} \int_{k_e a}^{\infty} \frac{y J_1^2(y)}{\sqrt{y^2 - (k_e a)^2}^3} \left[-e^{-\sqrt{y^2 - (k_e a)^2} \cdot 2/\rho} \right.$$

$$+ 4e^{-\sqrt{y^2 - (k_e a)^2} \cdot 3/2\rho} - 4e^{-\sqrt{y^2 - (k_e a)^2} \cdot 1/\rho} - 4e^{-\sqrt{y^2 - (k_e a)^2} \cdot 1/2\rho}$$

$$\left. + 5 - 2\sqrt{y^2 - (k_e a)^2} \cdot 1/\rho \right] dy - \frac{1}{1-X} \int_0^{k_p a} \frac{y^3 J_1^2(y)}{\sqrt{(k_p a)^2 - y^2}^5}$$

$$\left[\sin(\sqrt{(k_p a)^2 - y^2} \cdot 2/\rho) - 4\sin(\sqrt{(k_p a)^2 - y^2} \cdot 3/2\rho) \right.$$

$$\left. + 4\sin(\sqrt{(k_p a)^2 - y^2} \cdot 1/\rho) + 4\sin(\sqrt{(k_p a)^2 - y^2} \cdot 1/2\rho) - 2\sqrt{(k_p a)^2 - y^2} \cdot 1/\rho \right] dy$$

$$-\frac{1}{1-x} \int_0^{\rho} \frac{y^3 J_1^2(y)}{k_p a \sqrt{y^2 - (k_p a)^2}} \left[e^{-\sqrt{y^2 - (k_p a)^2}} \frac{2}{\rho} - 4 e^{-\sqrt{y^2 - (k_p a)^2}} \frac{3}{2\rho} \right.$$

$$\left. - 4 e^{-\sqrt{y^2 - (k_p a)^2}} \frac{1}{\rho} - 4 e^{-\sqrt{y^2 - (k_p a)^2}} \frac{1}{2\rho} + 5 \right.$$

$$\left. - 2 \sqrt{y^2 - (k_p a)^2} \frac{1}{\rho} \right] dy + \frac{jx}{1-x} \int_0^{k_e a} \frac{y J_1^2(y)}{\sqrt{(k_e a)^2 - y^2}} \frac{1}{3} \cdot$$

$$\left[-\cos(\sqrt{(k_e a)^2 - y^2}) \frac{2}{\rho} + 4 \cos(\sqrt{(k_e a)^2 - y^2}) \frac{3}{2\rho} \right.$$

$$\left. - 4 \cos(\sqrt{(k_e a)^2 - y^2}) \frac{1}{\rho} - 4 \cos(\sqrt{(k_e a)^2 - y^2}) \frac{1}{2\rho} \right.$$

$$\left. + 5 \right] dy + \frac{j}{1-x} \int_0^{k_p a} \frac{y^3 J_1^2(y)}{\sqrt{(k_p a)^2 - y^2}} \frac{1}{5} \cdot$$

$$\left[-\cos(\sqrt{(k_p a)^2 - y^2}) \frac{2}{\rho} + 4 \cos(\sqrt{(k_p a)^2 - y^2}) \frac{3}{2\rho} \right.$$

$$\left. - 4 \cos(\sqrt{(k_p a)^2 - y^2}) \frac{1}{\rho} - 4 \cos(\sqrt{(k_p a)^2 - y^2}) \frac{1}{2\rho} \right.$$

$$\left. + 5 \right] dy$$

$$\frac{-j}{1-X} \frac{\pi(k_p a)^2 J_1^2(k_p a)}{12\rho^3} \quad (2-47)$$

Note that in this case $\omega > \omega_p$, there is a real part for the impedance which turns out to be appreciable in some cases. In the above

$k_e \ell = \sqrt{1-X} k_0 \ell =$ electrical "phase length" of the antenna

$k_p \ell = (c/u) k_e \ell =$ acoustical "phase length" of the antenna

2.4 Numerical Computations and Discussion of Results

The numerical integrations were performed on the 7094 computer facility using an available Gauss quadrature subroutine. Library subroutines were also used to generate the Bessel functions. Several similar integrals containing products of Bessel functions over a 0 to ∞ range for which an exact value was known were also computed using the same subroutines. In these cases the error was found to be less than 1 percent. Hence, the numerical results are sufficiently accurate to be meaningful.

The results are given in Tables 1-6. The impedance depends on the following parameters: X (square of the ratio of the plasma frequency to the operating frequency), $\alpha_e \ell$ or $k_e \ell$ (the electrical "phase length" of the antenna), $\alpha_p \ell$ or $k_p \ell$ (the acoustical "phase length" of the antenna), and ρ (the ratio of antenna radius to half length). As expected the impedance scales in frequency. Temperature effects

show up in the ratio of α_e/α_p or k_e/k_p which is equal to u/c . u is proportional to the square root of the temperature.

In Table 1 X , $\alpha_p l$ and ρ are held constant while $\alpha_e l$ is varied by varying c/u .

Table 1. Effects of Electrical Phase Length ($\alpha_e l$) on Impedance

$$X = 1.25, \alpha_p l = 20, \rho = .05$$

<u>ZJEM</u>	<u>ZJP</u>	<u>ZF</u>	<u>Z_{in}</u>	<u>$\alpha_e l$</u>	<u>c/u</u>
j2395	-j756	-j2.93	j1636	.20	100
j11975	-j3782	-j14.8	j8178	.04	500
j23949	-j7563	-j29.6	j16357	.02	1000
j119750	-j37815	-j148	j81783	.004	5000
j239490	-j75631	-j296	j163570	.002	10,000

It can be seen that plasma waves influence the impedance in this case.² However, the relative effect is independent of $\alpha_e l$ (or c/u) for a fixed $\alpha_p l$ as the impedances are proportional to $1/\alpha_e l$. ZJP , $ZJEM$, and Z_{in} are in the same order of magnitude, but ZF is several orders of magnitude lower and thus the effect of the acoustic sources on impedance is negligible in this case. Note that $ZJEM$ is an inductive impedance for $\omega < \omega_p$ as the relative permittivity of the plasma ($1 - x$) is less than zero.

Table 1 indicates that $\alpha_e l$ has no effect on the relative magnitudes of the different impedance contributions. In Tables 2 and 3 the effects of $\alpha_p l$ and X are illustrated. It can be seen that in the cold plasma limit ($c/u \gg 1$, or $\alpha_p l \gg 1$) that plasma waves have little

²It will be shown later that plasma waves have an appreciable effect on impedance if the acoustical phase length is approximately 50 or smaller.

Table 2. Effects of $\alpha_p \ell$ on Impedance

$$X = 1.25, \rho = .05, c/u = 100$$

<u>ZJEM</u>	<u>ZJP</u>	<u>ZF</u>	<u>Z_{in}</u>	<u>$\alpha_p \ell (100 \alpha_e \ell)$</u>
j 798	-j 81.8	-j .7	j 716	60
j 958	-j 119	-j .9	j 838	50
j 1198	-j 188	-j 1.21	j 1009	40
j 1597	-j 337	-j 1.75	j 1258	30
j 2395	-j 756	-j 2.93	j 1636	20
j 2994	-j 1158	-j 3.80	j 1831	16
j 4790	-j 2690	-j 5.98	j 2094	10
j 11975	-j 11072	-j 7.36	j 895	4
j 12282	-j 11468	-j 7.27	j 807	3.9
j 12605	-j 11885	-j 7.18	j 712	3.8
j 12946	-j 12327	-j 7.08	j 611	3.7
j 13305	-j 12796	-j 6.97	j 503	3.6
j 13685	-j 13292	-j 6.85	j 386	3.5
j 14088	-j 13820	-j 6.72	j 261	3.4
j 14968	-j 14980	-j 6.42	-j 18.3	3.2
j 15966	-j 16302	-j 6.09	-j 342	3.0
j 17107	-j 17821	-j 5.71	-j 720	2.8
j 18423	-j 19581	-j 5.28	-j 1164	2.6
j 19958	-j 21642	-j 4.83	-j 1689	2.4
j 21772	-j 24085	-j 4.33	-j 2317	2.2
j 23949	-j 27021	-j 3.81	-j 3076	2.0
j 47899	-j 59320	-j 1.25	-j 11423	1.0
j119750	-j 154920	-j .18	-j 35176	.4

Table 3. Effects of X on Impedance

$$\alpha_p l = 10, \quad \rho = .05, \quad c/u = 100$$

<u>ZJEM</u>	<u>ZJP</u>	<u>ZF</u>	<u>Z_{in}</u>	<u>X</u>
j 10710	-j 5052	-j 19.9	j 5639	1.05
j 7573	-j 3742	-j 12.3	j 3819	1.1
j 5355	-j 2887	-j 7.2	j 2461	1.2
j 3387	-j 2282	-j 3.29	j 1101	1.5
j 2395	-j 2152	-j 1.82	j 241	2.0
j 2284	-j 2154	-j 1.68	j 128	2.1
j 2186	-j 2161	-j 1.57	j 24.0	2.2
j 2142	-j 2165	-j 1.52	-j 24.6	2.25
j 2101	-j 2170	-j 1.47	-j 71.2	2.3
j 2061	-j 2176	-j 1.43	-j 116	2.35
j 2024	-j 2182	-j 1.39	-j 160	2.4
j 1956	-j 2196	-j 1.31	-j 242	2.5
j 1837	-j 2228	-j 1.19	-j 392	2.7
j 1694	-j 2282	-j 1.06	-j 590	3.0
j 1198	-j 2690	-j .654	-j 1493	5.0

effect on impedance, as Z_{JEM} and Z_F are both at least an order of magnitude less than Z_{in} . For values of $\alpha_p l \approx 50$ or less Z_{JP} and Z_{JEM} are roughly the same order of magnitude, whereas Z_F is at least three orders of magnitude smaller. However, note that Z_{JEM} and Z_{JP} are of opposite sign and eventually appear to reach some sort of resonance where they cancel each other. This result was also evident in Balmain's (1965) expression for impedance. In this region Z_F is about four orders of magnitude smaller than Z_{JEM} and Z_{JP} and will cause only a slight shift in the point where resonance occurs. It is highly questionable whether this would be noticeable. Table 3 essentially illustrates the same effect.

In conclusion it appears as if the induced acoustic sources along the antenna surface have little effect on impedance when $\omega < \omega_p$. As expected, the plasma waves induced by the current distribution strongly influence the total input impedance when the acoustical "phase length" of the antenna is approximately 50 or smaller.

Intuitively, one would expect the same results when $\omega > \omega_p$. This is indeed the case as Tables 4-6 indicate. In this case the resonance phenomena (Z_{JEM} and Z_{JP} canceling each other) no longer appears. Under these conditions there is also an appreciable real part to the antenna impedance when $.5 \lesssim k_p l \lesssim 60$, indicating there is an appreciable amount of power radiated from the antenna in the form of a plasma wave. Note that both the real part and imaginary parts of Z_F are always approximately an order of magnitude less than Z_{JEM} , Z_{JP} , and Z_{in} and thus it is reasonable to neglect the effect of the acoustic sources on impedance.

Table 4. Effect of $k_e \ell$ on Impedance

$$X = .70, \rho = .05, k_p \ell = 20$$

<u>ZJEM</u>	<u>ZJP</u>	<u>ZF</u>	<u>Z_{in}</u>	<u>k_e ℓ</u>	<u>c/u</u>
-j2186	690-j180	18.2+j45.5	708-j2321	.2	100
-j4373	1380-j360	36+j91	1416-j4642	.1	200
-j10931	3449-j901	91+j227	3540-j11605	.04	500
-j21863	6899-j1802	182+j455	7081-j23210	.02	1000
-j43725	13798-j3603	363+j910	14160-j46420	.01	2000
-j109310	34494-j9008	908+j2275	35400-j116050	.004	5000
-j218630	68988-j18015	1817+j4549	70805-j232090	.002	10,000

Table 5. Effect of $k_p \ell$ on Impedance

$$X = .70, \rho = .05, c/u = 100$$

<u>ZJEM</u>	<u>ZJP</u>	<u>ZFP</u>	<u>Z_{in}</u>	<u>k_p ℓ (k_e ℓ = k_p ℓ / 100)</u>
-j729	26.9+j26.7	4.01+j2.36	30.9-j700	60
-j875	2.8+j8.32	.0961+j.0714	2.9-j866	50
-j1093	35.7-j77.5	2.3+j2.78	38-j1168	40
-j1458	219-j201	9.8+j16.5	228-j1642	30
-j2186	690-j180	18.2+j45.5	708-j2321	20
-j4373	1961+j930	27.9+j119	1989-j3324	10
-j10931	4767+j6936	62.3-j36	4829-j4031	4
-j21863	3442+j18118	.916+j5.87	3443-j3739	2
-j43725	1156+j33989	≈ 0	1155-j9736	1
-j109310	201+j80988	≈ 0	201-j28326	.4

Table 6. Effects of X on Impedance

$$k_p \ell = 10, \quad \rho = .05, \quad c/u = 100$$

<u>ZJEM</u>	<u>ZJP</u>	<u>ZF</u>	<u>Z_{in}</u>	<u>X</u>
-j2525	162+j76.7	3.8+j13.1	166-j2435	.1
-j2678	343+j163	7.33+j26.4	350-j2489	.2
-j2863	550+j261	10.7+j40.1	561-j2561	.3
-j3092	792+j376	14.2+j55.0	807-j2261	.4
-j3387	1085+j515	17.9+j71.9	1103-j2800	.5
-j3787	1456+j690	22.3+j92.1	1478-j3004	.6
-j4373	1961+j930	27.9+j119	1989-j3324	.7
-j5355	2745+j1302	36.5+j160	2781-j3894	.8
-j7573	4367+j2071	54.3+j244	4422-j5258	.9
-j10710	6519+j3092	78.6+j357	6598-j7261	.95
-j23949	15191+j7205	179+j819	15370-j15925	.99

III. THE IMPEDANCE OF A BICONICAL DIPOLE IN A WARM PLASMA

3.1 Formulation of the Problem in a Spherical Geometry

In the previous section the impedance of a cylindrical dipole was investigated. A variational expression was derived for the impedance and hence, the accuracy of the solution is strongly dependent on how well one has guessed the induced current and pressure distribution along the antenna. In order to determine these exactly, one must solve a pair of coupled integral equations. As noted previously, this is generally very difficult, and thus one tends to look for an easier antenna model to analyze.

Wait (1964) and Galejs (1966) have investigated the impedance properties of a slotted sphere and a waveguide-backed infinite slotted plane, respectively. Due to the close similarity between a slotted sphere antenna and a biconical antenna as far as the exterior problem is concerned, this antenna was decided upon. The biconical dipole in free space has been investigated extensively by Tai (1948, 1949), Schelkunoff (1946) and Smith (1947) by means of modal solutions. However, it is no longer possible to obtain these modal solutions in a simple way when the antenna is immersed and everywhere in contact with a warm plasma. This is due to the fact that the EM and acoustic waves have different propagation constants (k_p and k_e) in the radial direction.

In order to circumvent this difficulty, this work will consider a dipole surrounded by a dielectric sphere as shown in Figure 5. For wide angle dipoles the sphere may be an adequate representation of

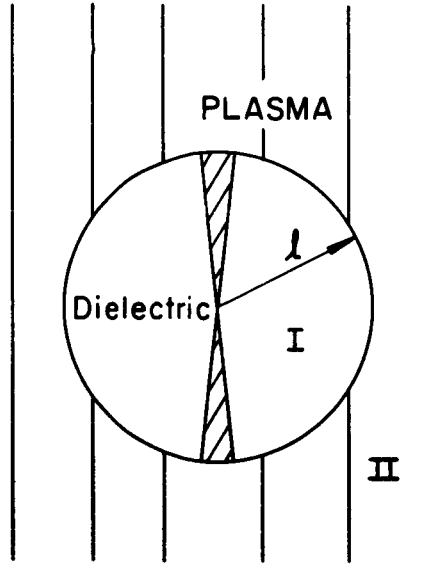

1 a

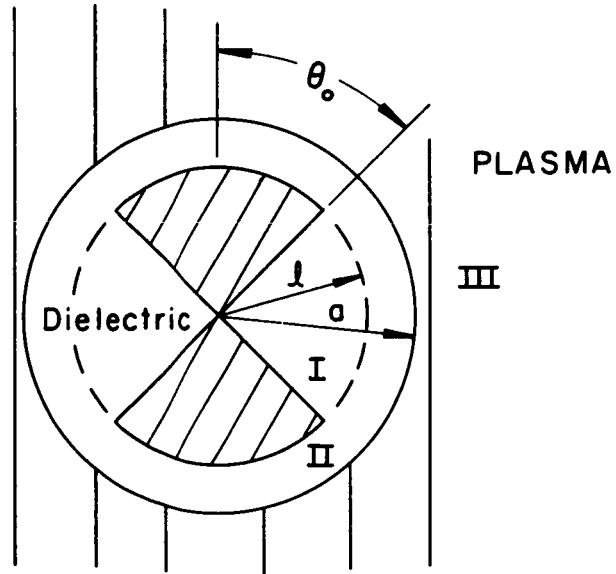

1 b

Figure 5. Problem geometry

the ion sheath formed around the antenna. Moreover, the geometry appears feasible for experimental verification by simply encasing the antenna in a suitable dielectric. In any event, the problem is tractable mathematically and yields some insight as to the effect of antenna size, ion sheath size and plasma parameters on antenna impedance. In the following the dielectric region is assumed to be free space, but a simple substitution yields solutions valid for any dielectric. The plasma model is the same one as was used in Section 2. The boundary between the dielectric and the plasma is assumed to be rigid (i.e., the mean radial electron velocity is zero), which is a physically reasonable assumption.

As shown in Figure 5, the compressible plasma occupies a space exterior to a sphere of radius ℓ (thin antenna) or a (thick antenna). Because of symmetry requirements, the fields will vary as functions only of r and θ in a spherical geometry. The resultant magnetic field will have only a ϕ component. In the following the treatment of the exterior problem for a thin antenna will be given briefly. A similar treatment is given by Wait (1964) for a slotted sphere.

From (2-7) and (2-8) the EM and acoustic waves satisfy the following wave equations in a source free region

$$\nabla_x \nabla_x \bar{H} - k_e^2 \bar{H} = 0 \quad \text{or} \quad \nabla^2 \bar{H} + k_e^2 \bar{H} = 0$$

$$\nabla^2 P + k_p^2 P = 0$$

For the case of a spherical geometry with the symmetry conditions imposed by a biconical antenna, these reduce to

$$r \frac{d^2}{dr^2} (r H_\phi) + \frac{\partial}{\partial \theta} \left(\frac{1}{\sin \theta} \frac{\partial}{\partial \theta} (\sin \theta H_\phi) \right) + k_e^2 r^2 H_\phi = 0 \quad (3-1)$$

$$\frac{\partial}{\partial r} \left(r^2 \frac{\partial P}{\partial r} \right) + \frac{1}{\sin \theta} \frac{\partial}{\partial \theta} (\sin \theta \frac{\partial P}{\partial \theta}) + k_p^2 r^2 P = 0 \quad (3-2)$$

It is easy to show that $r^{-1} R_k(k_e r) \frac{\partial}{\partial \theta} P_k(\cos \theta)$ and $r^{-1} R_k(k_p r) P_k(\cos \theta)$ are solutions of (3-1) and (3-2) respectively where¹

$$R_k(k_{e,p} r) = (k_{e,p} r)^{1/2} H_{k+1/2}^{(2)}(k_{e,p} r), \quad H_{k+1/2}^{(2)}(k_{e,p} r)$$

is a Hankel function of the second kind (satisfies radiation condition at infinity) of order $k + 1/2$ and $P_k(\cos \theta)$ is a Legendre polynomial of the first kind. Thus, H_ϕ and P may be represented as

$$H_\phi = -\frac{1}{2\pi r} \sum_{k=1,3,\dots} \frac{b_k R_k(k_e r)}{k(k+1) R_k(k_e l)} \frac{\partial}{\partial \theta} P_k(\cos \theta) \quad (3-3)$$

$$P = -\frac{1}{2\pi r} \sum_{k=1,3,\dots} \frac{c_k}{k(k+1)} \frac{R_k(k_r r)}{R_k(k_p l)} P_k(\cos \theta) \quad (3-4)$$

where only odd values of k are required in the summations due to symmetry. The remaining fields in the plasma region are derivable from H_ϕ and P in conjunction with equations (2-1) - (2-5). In determining the terminal admittance only the values of v_r and E_θ will be

¹Note k is an integer when it appears without a subscript; $k_{e,o,p}$ are propagation constants.

required. They are given in a spherical geometry by

$$E_{\theta} = -\frac{1}{j\omega\epsilon r} \frac{\partial}{\partial r}(rH_{\phi}) - \frac{e}{m\epsilon\omega^2 r} \frac{\partial P}{\partial \theta} \quad (3-5)$$

$$V_r = -\frac{e}{m\epsilon\omega^2 r \sin\theta} \frac{\partial}{\partial \theta}(\sin\theta H_{\phi}) - \frac{\epsilon_0}{j\omega m n_0 \epsilon} \frac{\partial P}{\partial r} \quad (3-6)$$

The unknown coefficients b_k and c_k in (3-3) and (3-4) are not independent of each other. The relationship between the two may be determined by invoking the rigid boundary condition $v_r = 0$ at $r = \ell$. Substituting (3-3) and (3-4) into (3-6) yields

$$V_r = -\sum_{k=1,3,\dots} \frac{e}{m\epsilon\omega^2 r} \frac{b_k}{2\pi r} \frac{R_k(k_p r)}{R_k(k_p \ell)} P_k(\cos\theta) + \frac{\epsilon_0}{j\omega m n_0 \epsilon} \frac{c_k}{2\pi k(k+1)} \frac{1}{R_k(k_p \ell)} \left(\frac{k_p}{r} R_k'(k_p r) - \frac{R_k(k_p r)}{r^2} \right) P_k(\cos\theta)$$

where $R_k'(k_p r) = \frac{d}{d(k_p r)} R_k(k_p r)$. But $v_r = 0$ at $r = \ell$ and hence,

equating the above expression to zero at $r = \ell$ yields the desired relationship between each individual c_k and b_k because of the orthogonal nature of the Legendre polynomials in the range $0 \leq \theta \leq \pi$. The relationship is

$$\frac{c_k}{b_k} = k(k+1) \frac{j\epsilon_0 n_0}{\epsilon_0 \omega} \left(\frac{R_k(k_p \ell)}{k_p \ell R_k'(k_p \ell) - R_k(k_p \ell)} \right) \quad (3-7)$$

In the following work the only field expressions required in the plasma region once c_k/b_k is known are those for the tangential electric and magnetic fields. H_{ϕ} is given by (3-3) while E_{θ} may be determined by

substituting (3-3), (3-4) and (3-7) into (3-5). After some algebraic simplification, the following expressions for the tangential electric and magnetic fields in the plasma region were derived.

$$H_{\phi} = -\frac{1}{r} \sum_{k=1,3,\dots} \frac{b_k}{2\pi k(k+1)} \frac{R_k(k_e r)}{R_k(k_e l)} \frac{d}{d\theta} P_k(\cos\theta) \quad (3-8)$$

$$E_{\theta} = -\frac{jZ}{r} \sum_{k=1,3,\dots} \frac{b_k}{2\pi k(k+1)} \frac{R'_k(k_e r)}{R_k(k_e l)} \frac{d}{d\theta} P_k(\cos\theta) \\ + \frac{j\epsilon^2 n_0}{m\epsilon_0 \omega^3 r^2} \sum_{k=1,3,\dots} \frac{b_k}{2\pi} \frac{R_k(k_p r)}{(k_p l R'_k(k_p l) - R_k(k_p l))} \frac{d}{d\theta} P_k(\cos\theta) \quad (3-9)$$

where $Z = \sqrt{\mu_0/\epsilon}$ = wave impedance of the plasma when replaced by an equivalent dielectric of permittivity ϵ .

3.2 The Thin Biconical Dipole

Equations (3-8) and (3-9) are expressions for the tangential electric and magnetic fields in the plasma region (II) as shown in Figure 5. Because of the similarity between the problem treated here and the free space problem treated by Tai (1948), his notation will be used where possible. The modal solutions in the dielectric region, which satisfy Maxwell's equations and the boundary conditions $E_r = 0$ at θ_0 and $\pi - \theta_0$, are as given by Tai (1948).

$$E_{\theta} = \frac{V Z_0}{r \sin\theta} \left[(1 + K Y_z) e^{-jk_0(r-l)} + (1 - K Y_z) e^{jk_0(r-l)} \right] \\ - \frac{j Z_0}{r} \sum_n \frac{a_n}{2\pi n(n+1)} \frac{S'_n(k_0 r)}{S_n(k_0 l)} \frac{d}{d\theta} L_n(\cos\theta) \quad (3-10)$$

$$H_{\phi} = \frac{V}{r \sin \theta} \left[(1 + KY_t) e^{-jk_0(r-l)} - (1 - KY_t) e^{jk_0(r-l)} \right]$$

$$= \frac{1}{r} \sum_n \frac{a_n}{2\pi n(n+1)} \frac{S_n(k_0 r)}{S_n(k_0 l)} \frac{d}{d\theta} L_n(\cos \theta)$$
(3-11)

where V is a constant which is proportional to the input voltage at the apexes of the cones, Y_t is the terminal admittance, K is the characteristic impedance of the cones (the impedance of an infinitely long antenna which is $= (Z_0/\pi) \log \cot \frac{\theta_0}{2}$), $L_n(\cos \theta)$ is a Legendre polynomial which vanishes at θ_0 , $\pi/2$, and $\pi - \theta_0$ (n is not an integer in general), and

$$S_n(k_0 r) = (k_0 r)^{1/2} J_{n+1/2}(k_0 r)$$

$$S_n'(k_0 r) = \frac{d}{d(k_0 r)} S_n(k_0 r)$$

where $J_{n+1/2}(k_0 r)$ is a Bessel function of the first kind of order $n + 1/2$. The a_n are unknown constants which are to be determined. Matching the tangential magnetic field (equating (3-8) and (3-11) and integrating from θ_0 to $\pi - \theta_0$ yields an expression for Y_t in terms of b_k

$$Y_t = \frac{Z_0}{4\pi^2 K^2} \sum_{k=1,3,\dots} \left(\frac{b_k}{V} \right) \frac{1}{k(k+1)} P_k(\cos \theta_0)$$
(3-12)

Once b_k is determined Y_t and also the input impedance may be easily determined. The similarity between Equations (3-8), (3-9), (3-10), (3-11) and Tai's equations 1, 2, 4, 5, 10 and 11 indicates that b_k may

be solved for in a similar manner to that used by Tai for a bicone in free space. This is, indeed, the case; however, it is much easier to solve for b_k by immediately invoking the small angle criterion.

Matching H_ϕ from θ_0 to $\pi - \theta_0$ at $r = l$ yields

$$\frac{V}{l \sin \theta} (2k Y_1) - \frac{1}{l} \sum_n \frac{a_n}{2\pi n(n+1)} \frac{\partial}{\partial \theta} L_n(\cos \theta) =$$

$$- \frac{1}{l} \sum_{k=1,3,\dots} \frac{b_k}{2\pi k(k+1)} \frac{\partial}{\partial \theta} P_k(\cos \theta)$$

Multiplying by $\sin(\theta) \frac{dL_m(\cos \theta)}{d\theta}$, using orthogonality properties of the Legendre functions and integrating from θ_0 to $\pi - \theta_0$ yields

$$- \frac{a_m}{2\pi} \int_{-\mu_0}^{\mu_0} L_m^2(u) du = - \sum_{k=1,3,\dots} \frac{b_k}{2\pi} \int_{-\mu_0}^{\mu_0} P_k(u) L_m(u) du$$

where $\mu = \cos(\theta)$. But the numbers m approach $1, 3, 5, \dots$ as $\theta_0 \rightarrow 0$ and the functions $L_m(u)$ become very much like $P_1(u), P_3(u), \dots$ except near θ_0 and $\pi - \theta_0$. Hence, $a_m \rightarrow b_k, m \rightarrow k$ as $\theta_0 \rightarrow 0$.

Matching E_θ from θ_0 to $\pi - \theta_0$ at $r = l$ yields

$$\frac{2V Z_0}{l \sin \theta} - \frac{j Z_0}{l} \sum_n \frac{a_n}{2\pi n(n+1)} \frac{S_n'(k_0 l)}{S_n(k_0 l)} \frac{\partial}{\partial \theta} L_n(\cos \theta)$$

$$= - \frac{j Z}{l} \sum_{k=1,3,\dots} \frac{b_k}{2\pi k(k+1)} \frac{R_k'(k_e l)}{R_k(k_e l)} \frac{\partial}{\partial \theta} P_k(\cos \theta)$$

$$+ \frac{j e^2 n_0}{m \epsilon_0 \omega^3 l^2} \sum_{k=1,3,\dots} \frac{b_k}{2\pi} \frac{R_k(k_p l)}{(k_p l R_k'(k_p l) - R_k(k_p l))} \frac{\partial}{\partial \theta} P_k(\cos \theta)$$

Multiplying by $\sin \frac{dP_s(\cos \theta)}{d\theta}$, where $s = 1, 3, \dots$ and integrating the left side from θ_0 to $\pi - \theta_0$, the right from $0 \rightarrow \pi$ (as $E_\theta = 0$ on the spherical caps) yields

$$-4VZ_0 P_s(\cos \theta_0) = jZ_0 \sum_n \frac{a_n}{2\pi n(n+1)} \frac{S_n'(k_0 l)}{S_n(k_0 l)} s(s+1) \int_{-\mu_0}^{\mu_0} L_n(\mu) P_s(\mu) d\mu$$

$$- \frac{jZ b_s}{2\pi s(s+1)} \frac{R_s'(k_e l)}{R_s(k_e l)} \frac{2s(s+1)}{2s+1} + \frac{j e^2 n_0}{m \epsilon \epsilon_0 \omega^3 l} \frac{b_s}{2\pi}$$

$$\frac{R_s(k_p l)}{(k_p l R_s'(k_p l) - R_s(k_p l))} \cdot \frac{2s(s+1)}{2s+1}$$

but as before in the limiting case of a thin dipole $n \rightarrow s$, $L_n \rightarrow P_s$, as $\theta_0 \rightarrow 0$ and the above equation becomes

$$4\pi = -j \left(\frac{b_s}{V} \right) \frac{S_s'(k_0 l)}{S_s(k_0 l)} \frac{1}{2s+1} + \frac{jZ}{Z_0} \left(\frac{b_s}{V} \right) \frac{R_s'(k_e l)}{R_s(k_e l)} \frac{1}{2s+1}$$

$$- \frac{j e^2 n_0}{m \epsilon \epsilon_0 \omega^3 l Z_0} \left(\frac{b_s}{V} \right) \frac{R_s(k_p l) s(s+1)}{(k_p l R_s'(k_p l) - R_s(k_p l))} \cdot \frac{1}{2s+1} \quad (3-13)$$

Solving (3-13) for b_k and substituting into (3-12) yields

$$Y_t = - \frac{jZ_0}{\pi K^2} \sum_{k=1,3,\dots} \frac{2k+1}{k(k+1)} A_k \quad (3-14)$$

where

$$A_k = \left\{ \frac{Z}{Z_0} \frac{R_k'(k_e l)}{R_k(k_e l)} - \frac{S_k'(k_o l)}{S_k(k_o l)} - \frac{X}{(1-X)k_o l} \frac{R_k(k_p l)}{(k_p l R_k'(k_p l) - R_k(k_p l))} \right\}^{-1} \quad (3-15)$$

If all temperature effects are neglected, i.e., the plasma is replaced by a dielectric with permittivity ϵ , only the first two terms would be present in A_k . Hence, the third term in A_k represents plasma or acoustic wave effects. Note that the first two terms in (3-15) check with Tai's equation (31) as expected. As they stand, (3-14) and (3-15) yield no immediate information. A computer was used to sum the series and the results are given in Section 3.4. However, it is possible to get a gross estimate of the impedance behavior by looking at some limiting values for $k_e l$, $k_p l$ and $k_o l$,

Case I $k_e l$, $k_o l$ and $k_p l \ll 1$

In this case the limiting values of the spherical Bessel functions are as given in Abramowitz (1965).

$$\sqrt{\frac{\pi}{2z}} J_{n+1/2}(z) \sim \frac{z^n}{1 \cdot 3 \cdot 5 \cdots (2n+1)}, \quad z \rightarrow 0$$

$$\sqrt{\frac{\pi}{2z}} Y_{n+1/2}(z) \sim -\frac{1 \cdot 3 \cdot 5 \cdots (2n-1)}{z^{n+1}}, \quad z \rightarrow 0$$

$$\sqrt{\frac{\pi}{2z}} H_{n+1/2}^{(2)}(z) \sim -\frac{1 \cdot 3 \cdot 5 \cdots (2n-1)}{z^{n+1}}, \quad z \rightarrow 0$$

Using these values it is easy to show that

$$A_k \sim \left\{ \frac{Z}{Z_0} \left(-\frac{k}{k_e l} \right) - \frac{k+1}{k_e l} + \frac{X}{1-X} \frac{k}{k_e l} \right\}^{-1} \quad (3-16)$$

All of these terms are approximately the same order of magnitude except when $X \approx 1$. Hence, the acoustic wave has a strong influence on impedance under these conditions and appears to be dominant near the plasma frequency ($X \approx 1$). However, this treatment has neglected the effects of Landau damping and its validity is questionable at frequencies near the plasma frequency.

Case II $k_e l, k_o l \ll 1, k_p l \gg 1$

For large arguments

$$J_{n+1/2}(z) \sim \sqrt{\frac{z}{\pi z}} \cos\left(z - \frac{n+1}{2} \pi\right)$$

$$Y_{n+1/2}(z) \sim \sqrt{\frac{z}{\pi z}} \sin\left(z - \frac{n+1}{2} \pi\right)$$

$$H_{n+1/2}^{(2)}(z) \sim \sqrt{\frac{z}{\pi z}} e^{-j\left(z - \frac{n+1}{2} \pi\right)}$$

In this case it can be shown that

$$A_k \sim \left\{ \frac{Z}{Z_0} \left(-\frac{k}{k_e l} \right) - \frac{k+1}{k_e l} + \frac{X}{(1-X)} \frac{k(k+1)}{k_e l k_p l} \right\}^{-1} \quad (3-17)$$

and since $k_p l \gg 1$, the third term will be negligible compared to the others, (i.e., this is the cold plasma limit, as $k_p l \gg k_e l$ implies $c/u \gg 1$).

Case III $k_e \ell, k_o \ell, k_p \ell \gg 1$

Here one finds

$$A_k \sim \left\{ \frac{Z}{Z_0} (-1) - \cot\left(k_o \ell - \frac{k\pi}{2}\right) + \frac{X k(k+1)}{(1-X) k_o \ell k_p \ell} \right\}^{-1}$$

and thus the third term will be negligible. Hence, acoustic effects are negligible for electrically large antennas ($k_e \ell \gg 1$).

3.3 The Thick Biconical Dipole

As in Section 3.2, expressions for the tangential electric and magnetic fields in regions I, II and III as shown in Figure 5b will be required in order to determine the antenna impedance. The field expressions for region III are the same as those in Equations (3-8) and (3-9) if ℓ is replaced by a . b_k is also replaced by d_k in this case. Hence, in region III

$$H_\phi = -\frac{1}{2\pi r} \sum_{k=1,3,\dots} \frac{d_k}{k(k+1)} \frac{R_k(k_e r)}{R_k(k_e a)} \frac{d}{d\theta} (P_k(\cos\theta)) \quad (3-18)$$

$$E_\theta = -\frac{jZ}{2\pi r} \sum_{k=1,3,\dots} \frac{d_k}{k(k+1)} \frac{R'_k(k_e r)}{R_k(k_e a)} \frac{d}{d\theta} P_k(\cos\theta) + j \frac{X}{1-X} \frac{Z_0}{k_o r^2} \sum_{k=1,3,\dots} \frac{d_k}{2\pi} \frac{R_k(k_p r)}{(k_p a R'_k(k_p a) - R_k(k_p a))} \frac{d}{d\theta} P_k(\cos\theta) \quad (3-19)$$

In region I the field expressions, which satisfy the boundary conditions and symmetry requirements imposed by the biconical antenna, are given in Tai (1949)

$$E_{\theta} = \frac{Z_0 I_0}{2\pi r \sin\theta} \left[K Y_{\pm} \sin k_0(l-r) - j \cos k_0(l-r) \right]$$

$$-j \frac{Z_0}{2\pi r} \sum_n \frac{a_n}{n(n+1)} \frac{S_n'(k_0 r)}{S_n(k_0 l)} \frac{\partial}{\partial \theta} L_n(\cos \theta) \quad (3-20)$$

$$H_{\phi} = \frac{I_0}{2\pi r \sin\theta} \left[\sin k_0(l-r) - j K Y_{\pm} \cos k_0(l-r) \right]$$

$$-\frac{1}{2\pi r} \sum_n \frac{a_n}{n(n+1)} \frac{S_n(k_0 r)}{S_n(k_0 l)} \frac{\partial}{\partial \theta} L_n(\cos \theta) \quad (3-21)$$

where all symbols are as previously defined and I_0 is a constant proportional to the antenna input current. Similarly in region II

$$H_{\phi} = -\frac{1}{2\pi r} \sum_{k=1,3,\dots} \frac{1}{k(k+1)} \left[b_k (R_k(k_0 r)/R_k(k_0 l)) + c_k (S_k(k_0 r)/S_k(k_0 l)) \right] \frac{\partial}{\partial \theta} P_k(\cos \theta) \quad (3-22)$$

$$E_{\theta} = -\frac{j Z_0}{2\pi r} \sum_{k=1,3,\dots} \frac{1}{k(k+1)} \left[b_k (R_k'(k_0 r)/R_k(k_0 l)) + c_k (S_k'(k_0 r)/S_k(k_0 l)) \right] \frac{\partial}{\partial \theta} P_k(\cos \theta) \quad (3-23)$$

Equations (3-18) - (3-23) contain four unknown a_k , b_k , c_k and d_k . Two of these may be eliminated on applying the appropriate boundary

conditions at the dielectric-plasma boundary, $r = a$. The continuity of H_ϕ implies that

$$-\frac{1}{2\pi a} \sum_{k=1,3,\dots} \frac{1}{k(k+1)} \left[b_k \frac{R_k(k_0 a)}{R_k(k_0 l)} + c_k \frac{S_k(k_0 a)}{S_k(k_0 l)} \right].$$

$$\frac{d}{d\theta} P_k(\cos \theta) = -\frac{1}{2\pi a} \sum_{k=1,3,\dots} \frac{d_k}{k(k+1)} \frac{R_k(k_e a)}{R_k(k_e a)}.$$

$$\frac{d}{d\theta} P_k(\cos \theta)$$

But due to the orthogonality properties of the Legendre polynomials this reduces to

$$d_k - c_k \frac{S_k(k_0 a)}{S_k(k_0 l)} = b_k \frac{R_k(k_e a)}{R_k(k_0 l)} \quad (3-24)$$

Similarly the continuity of E_θ at $r = a$ yields another equation

$$\left[\frac{Z}{Z_0} \frac{R_k'(k_e a)}{R_k(k_e a)} - \frac{X}{1-X} \frac{k(k+1)}{k_0 a (k_p a R_k'(k_p a) - R_k(k_p a))} \right] d_k$$

$$- \left[\frac{S_k'(k_0 a)}{S_k(k_0 l)} \right] c_k = \left[\frac{R_k'(k_0 a)}{R_k(k_0 l)} \right] b_k \quad (3-25)$$

On solving for c_k in terms of b_k one finds

$$c_k / b_k = V_k = \left(\frac{R_k'(k_0 a)}{R_k(k_0 l)} - \frac{R_k(k_0 a)}{R_k(k_0 l)} \bar{N}_k \right) / \left(-\frac{S_k'(k_0 a)}{S_k(k_0 l)} + \frac{S_k(k_0 a)}{S_k(k_0 l)} \bar{N}_k \right) \quad (3-26)$$

where

$$\bar{N}_k = \frac{\sum R'_k(k_c a)}{\sum_0 R_k(k_c a)} - \frac{X}{(1-X)k_0 a} \frac{k(k+1) R_k(k_p a)}{(k_p a R'_k(k_p a) - R_k(k_p a))} \quad (3-27)$$

The second term in the above expression for \bar{N}_k represents acoustic effects. Equating it to zero is equivalent to replacing the plasma with a dielectric of relative permittivity $(1-X)$. On substituting V_{k_b} for c_k in (3-22) and (3-23) and rewriting (3-20) and (3-21) for convenience, the following expressions are obtained for the tangential electric and magnetic fields. In region I

$$E_\theta = \frac{Z_0 I_0}{2\pi r \sin\theta} [K Y_t \sin k_0(l-r) - j \cos k_0(l-r)]$$

$$- j \frac{Z_0}{2\pi r} \sum_n \frac{a_n}{n(n+1)} \frac{S'_n(k_0 r)}{S_n(k_0 l)} \frac{\partial}{\partial \theta} L_n(\cos \theta) \quad (3-28)$$

$$H_\phi = \frac{I_0}{2\pi r \sin\theta} [\sin k_0(l-r) - j K Y_t \cos k_0(l-r)]$$

$$- \frac{1}{2\pi r} \sum_n \frac{a_n}{n(n+1)} \frac{S_n(k_0 r)}{S_n(k_0 l)} \frac{\partial}{\partial \theta} L_n(\cos \theta) \quad (3-29)$$

In region II

$$E_\theta = -\frac{j Z_0}{2\pi r} \sum_{k=1,3,\dots} \frac{b_k}{k(k+1)} \left[\frac{R'_k(k_0 r)}{R_k(k_0 l)} + \right.$$

$$\left. V_k \frac{S'_k(k_0 r)}{S_k(k_0 l)} \right] \frac{\partial}{\partial \theta} P_k(\cos \theta) \quad (3-30)$$

$$H_{\phi} = -\frac{1}{2\pi r} \sum_{k=1,3,\dots} \frac{b_k}{k(k+1)} \left[\frac{R_k(k_0 r)}{R_k(k_0 l)} + V_k \frac{S_k(k_0 r)}{S_k(k_0 l)} \right] \frac{d}{d\theta} P_k(\cos \theta) \quad (3-31)$$

These equations are the same as Tai's (1949) equations (1) - (4) except for the additional V_k term in (3-30) and (3-31). On letting a tend to infinity and introducing a small loss into the medium, it may be easily verified that V_k tends to zero, thus yielding Tai's (1949) result. At present a method to determine the unknown constants a_n and b_k is unknown except for the case of the very thin dipole treated in Section 3.2. However, an integral equation may be easily derived for the tangential electric field at $r = l$. Using this integral equation, it is possible to derive a variational expression for Y_t . Due to the similarity of Tai's equations (1) - (4) and Equations (3-28) - (3-31) only a brief outline of the procedure is given here.

For convenience in writing, the following definitions will be introduced

$$P'_k(\cos \theta) = \frac{d}{d\theta} P_k(\cos \theta) \quad , \quad L'_n(\cos \theta) = \frac{d}{d\theta} L_n(\cos \theta)$$

$$M_k(k_0 l) = \frac{R'_k(k_0 l)}{R_k(k_0 l)} \quad , \quad N_n(k_0 l) = \frac{S'_n(k_0 l)}{S_n(k_0 l)} \quad , \quad O_k(k_0 l) = \frac{S'_k(k_0 l)}{S_k(k_0 l)}$$

$$I_{nn} = \int_{\theta_0}^{\pi - \theta_0} L_n^2(\cos \theta) \sin \theta d\theta \quad , \quad I_{kk} = \int_0^{\pi} P_k^2(\cos \theta) \sin \theta d\theta$$

The continuity of the tangential electric field at $r = \ell$ yields the following equations

$$-j \frac{Z_0}{2\pi\ell} \sum_{k=1,3,\dots} \frac{b_k}{k(k+1)} [M_k + V_k O_k] P_k' = \begin{cases} E_a(\theta) & \theta_0 \leq \theta \leq \pi - \theta_0 \\ 0 & \text{otherwise} \end{cases} \quad (3-32)$$

and

$$- \frac{j Z_0 I_0}{2\pi\ell \sin \theta} - \frac{j Z_0}{2\pi\ell} \sum_n \frac{a_n}{n(n+1)} N_n L_n' = E_a(\theta) \quad (3-33)$$

where $E_a(\theta)$ is the tangential electric field in the aperture $\theta_0 \leq \theta \leq \pi - \theta_0$ at $r = \ell$. Multiplying (3-32) by $P_r'(\cos \theta) \sin \theta$ and integrating from 0 to π and applying the orthogonality properties of $P_k'(\cos \theta)$ over this range yields

$$- \frac{j Z_0}{2\pi\ell} b_r [M_r + V_r O_r] I_{rr} = \int_{\theta_0}^{\pi - \theta_0} E_a(\theta) P_r'(\cos \theta) \sin \theta d\theta \quad (3-34)$$

where $r = 1, 3, \dots$

Integrating (3-33) from θ_0 to $\pi - \theta_0$ yields a relationship between I_0 and $E_a(\theta)$

$$I_0 = \frac{j\ell}{K} \int_{\theta_0}^{\pi - \theta_0} E_a(\theta) d\theta \quad (3-35)$$

Multiplying (3-33) by $L_m'(\cos \theta) \sin \theta$ and integrating from θ_0 to $\pi - \theta_0$ yields

$$a_m = \frac{j 2\pi\ell}{Z_0} \frac{1}{N_m I_{mm}} \int_{\theta_0}^{\pi - \theta_0} E_a(\theta) L_m'(\cos \theta) \sin \theta d\theta \quad (3-36)$$

On matching the tangential magnetic fields in regions I and II (equating (3-29) and (3-31) at $r = l$ and substituting for b_r , I_0 and a_m from (3-34) - (3-36) the following integral equation for $E_a(\theta)$

results

$$\frac{Y_t}{2\pi \sin \theta} \int_{\theta_0}^{\pi-\theta_0} E_a(\theta) d\theta - \frac{j}{Z_0} \sum_n \frac{L_n'(\cos \theta)}{n(n+1)N_n I_{nn}}$$

$$\int_{\theta_0}^{\pi-\theta_0} E_a(\theta) L_n'(\cos \theta) \sin \theta d\theta = -\frac{j}{Z_0} \sum_{k=1,3,\dots}$$

$$\frac{[1+V_k] P_k'(\cos \theta)}{k(k+1)[M_k+V_k O_k] I_{kk}} \int_{\theta_0}^{\pi-\theta_0} E_a(\theta) P_k'(\cos \theta) \sin \theta d\theta \quad (3-37)$$

Multiplying (3-37) by $E_a(\theta) \sin \theta$ and integrating from θ_0 to $\pi - \theta_0$ yields the variational statement for the terminal admittance Y_t in terms of the aperture field $E_a(\theta)$.

$$Y_t = \frac{j2\pi}{Z_0} \frac{1}{\left[\int_{\theta_0}^{\pi-\theta_0} E_a(\theta) d\theta \right]^2} \left\{ \sum_n \frac{1}{n(n+1) I_{nn}} \right.$$

$$\left. \left[\int_{\theta_0}^{\pi-\theta_0} E_a(\theta) L_n'(\cos \theta) \sin \theta d\theta \right]^2 - \sum_{k=1,3,\dots} \frac{1+V_k}{k(k+1)(M_k+V_k O_k) I_{kk}} \right.$$

$$\left. \left[\int_{\theta_0}^{\pi-\theta_0} E_a(\theta) P_k'(\cos \theta) \sin \theta d\theta \right]^2 \right.$$

(3-38)

To evaluate Y_t as given in (3-38) an appropriate trial function must be chosen for $E_a(\theta)$. In theory one could expand $E_a(\theta)$ in a complete set of orthogonal functions and solve for the expansion coefficients using the Rayleigh-Ritz procedure. The following set immediately suggests itself

$$E_a(\theta) = -\frac{A_0}{\sin \theta} + \sum_n A_n L_n'(\cos \theta) \quad (3-39)$$

Note (3-39) gives rise to a field of the same form as in (3-28). In order to simplify the mathematics, consider only the first term in (3-39) as a first approximation to $E_a(\theta)$. In order to justify this assumption one could truncate the series in (3-39) after a finite number of terms and compare the results. However, this is a tedious process at best. Tai (1949) has found that the above approximation yields reliable results for wide angle biconical dipoles in free space.

On the other hand, Galejs (1966) has found for a waveguide-backed slotted plane that the inclusion of a second trial function which varies over the waveguide aperture in the same way as the surface wave, supported by this geometry in addition to the principal waveguide mode as a first trial function, has a pronounced effect on the slot admittance. However, the results for a thin antenna and a thick antenna using the above first order approximation are in excellent qualitative agreement. Acoustic effects are also quite noticeable, whereas Galejs found that the principal waveguide mode alone as a trial function had no appreciable acoustic effect in many cases. This is partially due

to the fact that for $k_p a \gg 1$ acoustic effects are slight. The slotted plane problem is thus similar to a bicone of infinite radius. For very large bicones ($k_p a \gg 1$) the surface wave contribution should be considered. On substituting $E_a(\theta) = -A_0/\sin \theta$ into (3-38), the following first order approximation was obtained for Y_t

$$Y_t = \frac{-j Z_0}{\pi K^2} \sum_{k=1,3,\dots} \frac{(1+V_k) Z P_k^2(\cos \theta_0)}{k(k+1) (M_k + V_k O_k) I_{kk}} \quad (3-40)$$

If V_k is zero, this expression is identical with Tai's (1949) equation (19).

(3-40) is the first order approximation for Y_t . Just as in the case of the thin dipole, limiting values of $k_e a$, $k_p a$ and $k_o a$ yield some insight as to when acoustic effects are important. Acoustic effects influence the impedance only through the expression for \bar{N}_k (3-27)

$$\bar{N}_k = \frac{Z}{Z_0} \frac{R'_k(k_e a)}{R_k(k_e a)} - \frac{X}{(1-X)k_o a} \frac{k(k+1) R_k(k_p a)}{(k_p a R'_k(k_p a) - R_k(k_p a))}$$

If acoustic effects are neglected (that is, the plasma is replaced simply by a dielectric with relative permittivity $(1-X)$) the only changes in the above solution for Y_t are that the second term in the expression for $\bar{N}_k = 0$. Consider three cases as in the case of a thin dipole. In Case I, $k_e a$, $k_p a$, $k_o a \ll 1$; then by analogy with (3-16),

$$\bar{N}_k \sim \left\{ \frac{Z}{Z_0} \left(-\frac{k}{k_e a} \right) + \frac{X}{1-X} \frac{k}{k_o a} \right\}$$

and the acoustic waves strongly influence the impedance as both terms are the same order of magnitude. Similarly for Case II, $k_e a, k_o a \ll 1$, $k_p a \gg 1$,

$$\bar{N}_k \sim \left\{ \frac{Z}{Z_0} \left(-\frac{k}{k_e a} \right) + \frac{X}{1-X} \frac{k(k+1)}{k_e a k_p a} \right\}$$

Now the second term is much smaller than the first and can be neglected. For Case III, $k_e a, k_p a, k_o a \gg 1$,

$$\bar{N}_k \sim \left\{ \frac{Z}{Z_0} (-1) + \frac{X k(k+1)}{(1-X) k_o a k_p a} \right\}$$

and as in the thin dipole case acoustic effects are negligible in this region.

3.4 Numerical Computations and Discussion of Results

Equations (3-14) and (3-40) constitute formal solutions for the terminal admittance of thin and wide angle biconical dipoles. Once the terminal admittance is known, the input impedance may be determined as in Schelkunoff (1952). In a manner similar to that used in determining the behavior of Y_t for limiting values of $k_o a$, $k_e a$ and $k_p a$ it can be shown that the individual terms in (3-14) and (3-40) behave as $1/k^2$ if $k \gg k_o a$, $k_e a$ and $k_p a$. Since the series

$$\sum_{k=1}^{\infty} \frac{1}{k^2} \approx \sum_{k=1}^{50} \frac{1}{k^2}$$

to about 1 percent, the series in (3-14) and (3-40) were also summed by taking the first fifty terms in the series. The series were summed

on a digital computer which was programmed to print out each term and the total sum. For values of $k_p a \gtrsim 25$ the fiftieth term in the series was at least two orders of magnitude smaller than the sum of the first fifty terms, which is a quite satisfactory percentage of error. In general it appears as if the number of terms necessary for convergence is $\approx 2 k_p a$. However, it has been shown previously that acoustic effects are negligible for large values of $k_p a$ and thus the first fifty terms in the series again gives satisfactory results. Thus, in all the graphs there is a range, in which $25 \lesssim k_p a \lesssim 50$, where no values were computed. However, this presents no problems as the general trend of the situation is indicated quite clearly by the data obtained over the other ranges.

The primary difficulty in summing the series lies in computing the spherical Bessel functions to a sufficient degree of accuracy. A procedure outlined by Weeks (1958) in which a straightforward upward recursion scheme is used to compute the $Y_{n+\frac{1}{2}}$ and a downward scheme for the $J_{n+\frac{1}{2}}$ was found to yield excellent results.

The results are presented in Figures 6-18. In all cases Y_t was found to be sensitive to small changes in $k_o \ell$ as this corresponds to a large change in $k_p \ell$. To improve the readability of the figures, only a few oscillations are shown on each graph. In all of the figures the subscript a denotes the inclusion of acoustic effects, while the subscript d denotes replacement of the plasma by an equivalent dielectric.

Figures 6 and 7 are plots of $K^2 Y_t$ and Z_{in} versus $k_o \ell$ for several values of X . The ratio of the velocity of light to the acoustic velocity in the gas is 100. It can be seen that as X approaches one

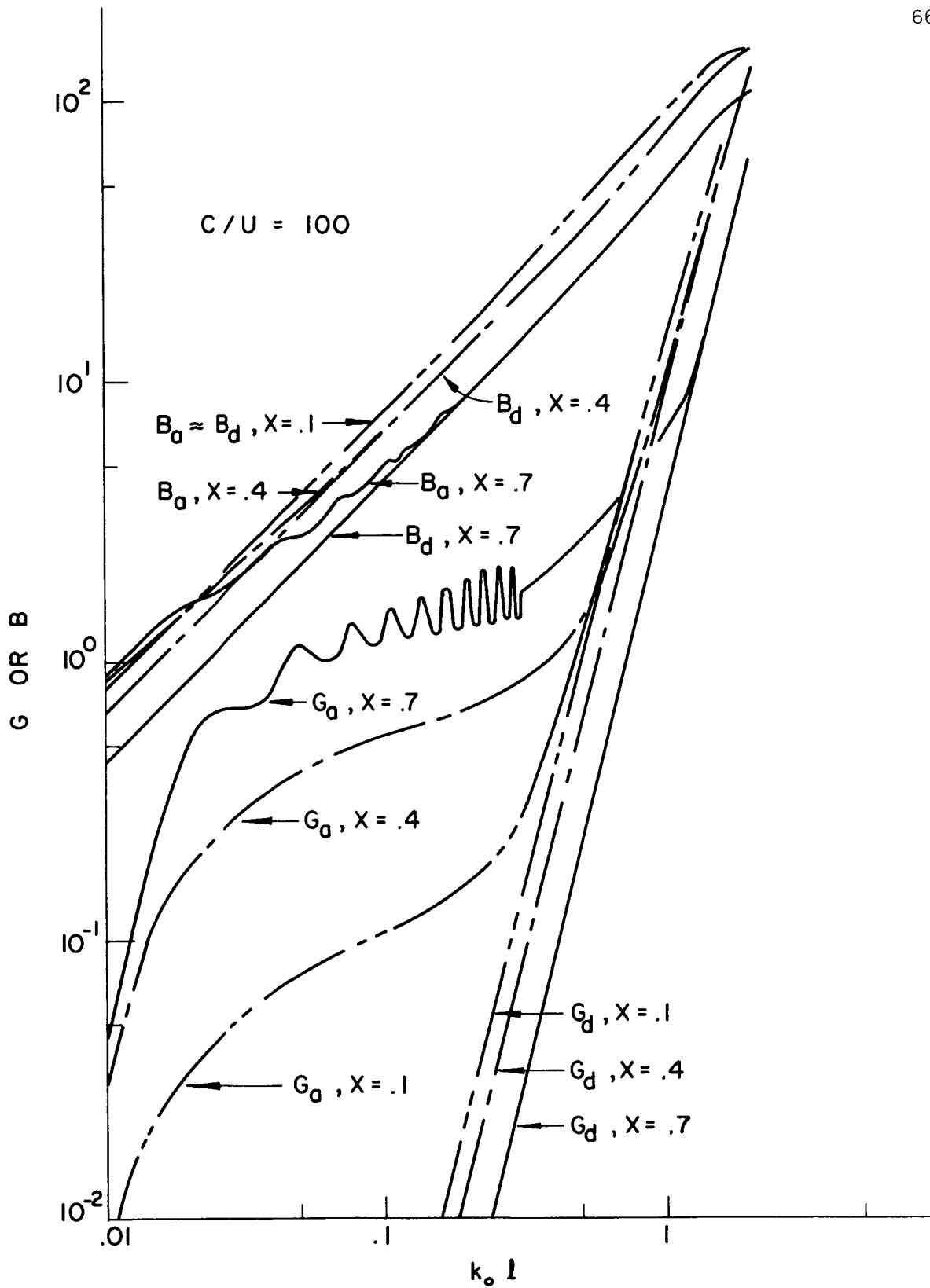

Figure 6. $K^2 Y_t = G_{a,d} + j B_{a,d}$ for a thin biconical antenna radiating into a warm plasma

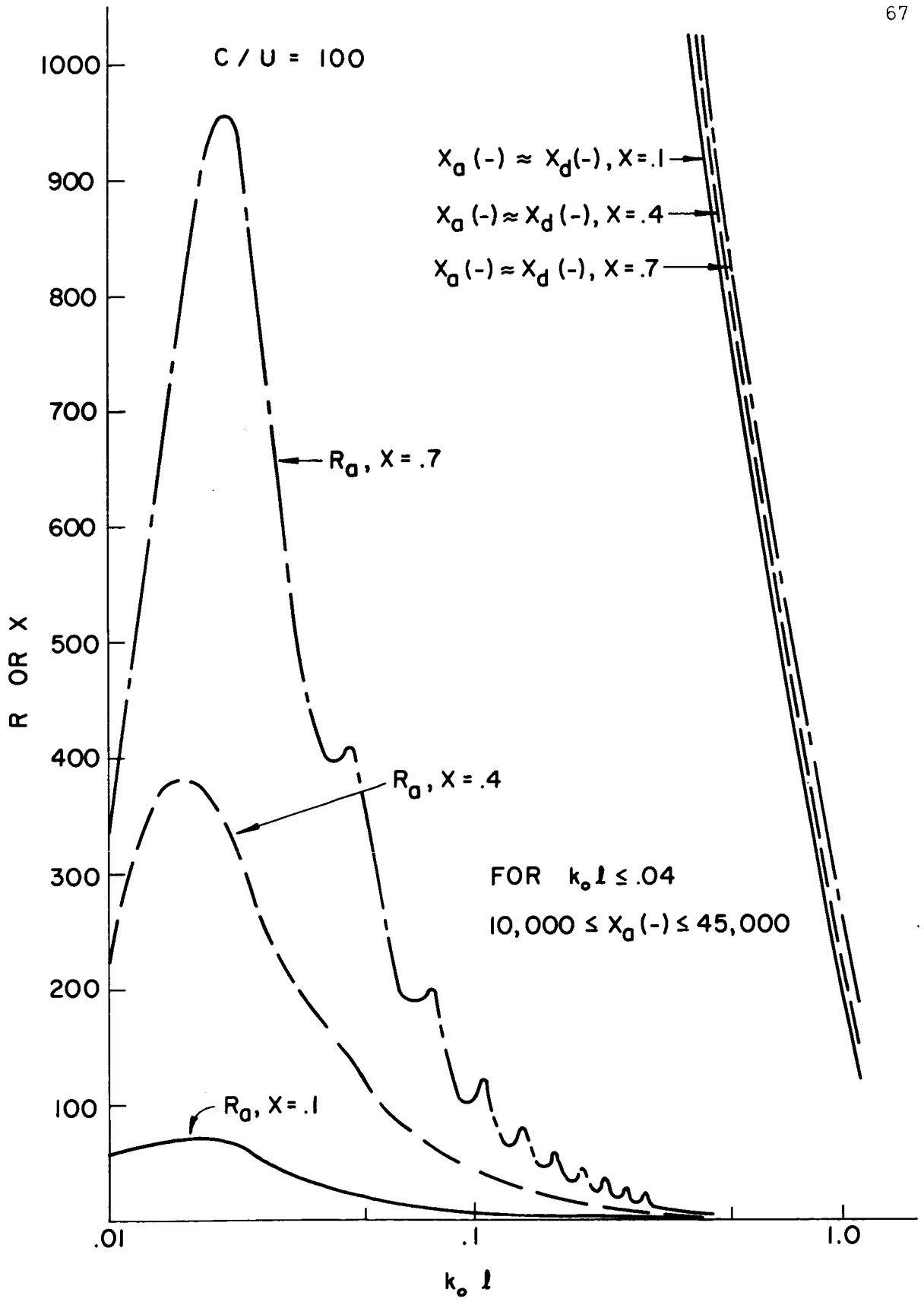

Figure 7. $Z_{in} = R_{a,d} + j X_{a,d}$ for a thin biconical antenna radiating into a warm plasma, $K = 500$ ohms

(i.e., the operating frequency of the antenna approaches the plasma frequency), acoustic effects are more pronounced. Only values of X less than one were considered, as no appreciable radiation occurs for X greater than one. The real part of $k^2 Y_t(G)$ is markedly changed in all cases if $k_o \ell \lesssim .3$; the imaginary part (B) also undergoes a slight change in some cases. However, even though G_a may be several orders of magnitude greater than G_d , G_a may still be negligible with respect to B_a . Furthermore, even though G_a and B_a may be the same order of magnitude, R_a (the real part of Z_{in}) may be much smaller than X_a (the imaginary part of Z_{in}) due to the relatively large value of K for thin dipoles. For example, when $X = .7$, the maximum values of G_a/B_a (.4) and R_a/X_a (.04) occur when $k_o \ell \approx .05$, $k_p \ell \approx 2.5$. In this case R_a appears to be large enough to make acoustic effects measurable. In many other cases, however, even though $R_a \gg R_d$ (indicating the acoustic power radiated is much greater than the EM power), it is still so small with respect to X_a that the effect will not be observable.

Figures 8 and 9 are similar to 6 and 7. However, acoustic effects are reduced over this range of $k_o \ell$ as c/u has increased by a factor of ten (we are approaching the cold plasma limit). In fact, now the maximum value of R_a/X_a (.025) occurs for $X = .7$ at $k_o \ell \approx .01$, $k_p \ell \approx 5.5$. However, by going to a smaller value of $k_o \ell$ this would increase. Acoustic effects seem to be most pronounced if $1 \lesssim k_p \ell \lesssim 3$ as is indicated in the following.

From the previous comments, it is obvious that antenna impedance depends strongly on the acoustic length of the antenna in addition to the electrical length. In order to illustrate this dependence

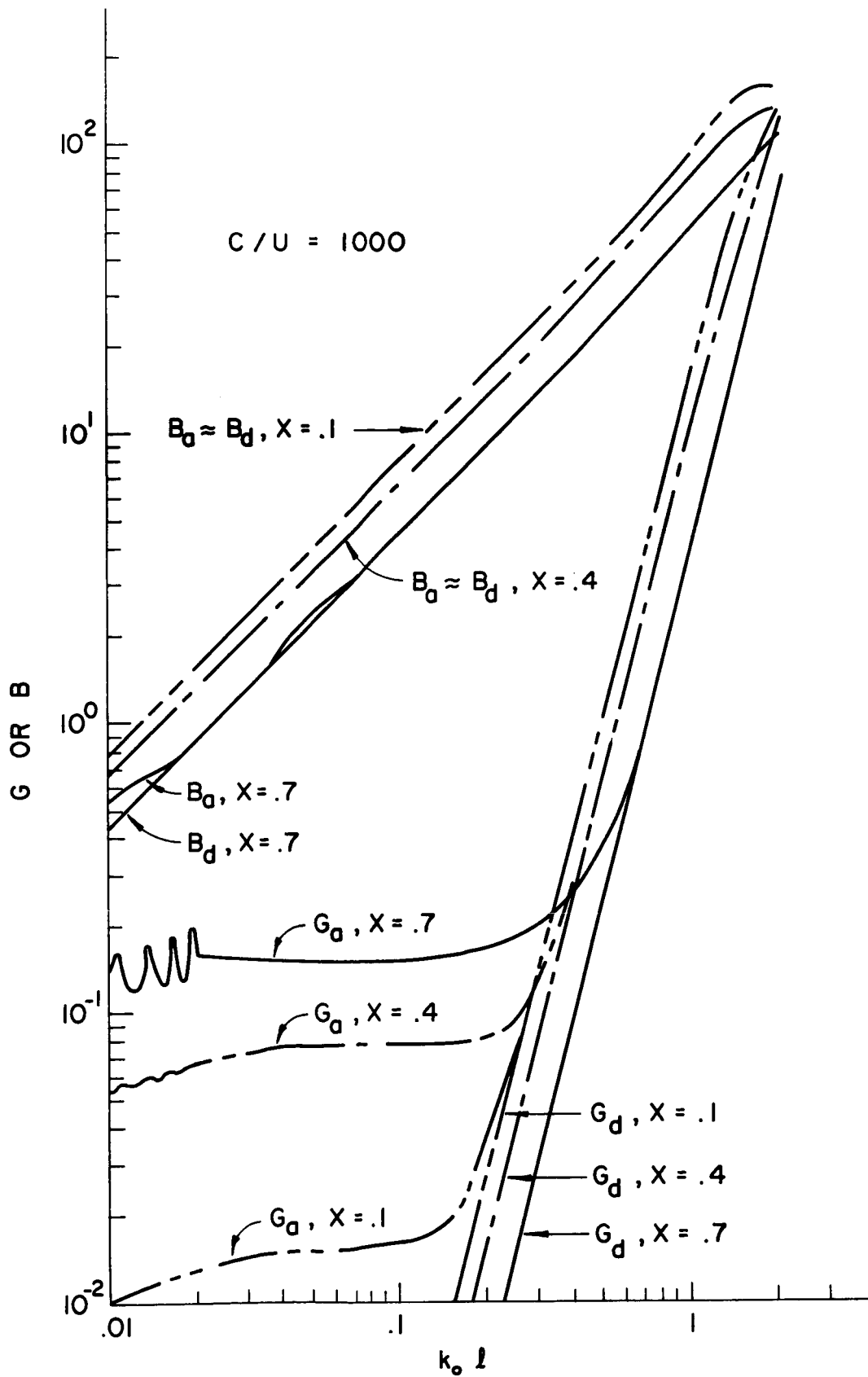

Figure 8. $K^2 Y_t = G_{a,d} + j B_{a,d}$ for a thin biconical antenna radiating into a warm plasma

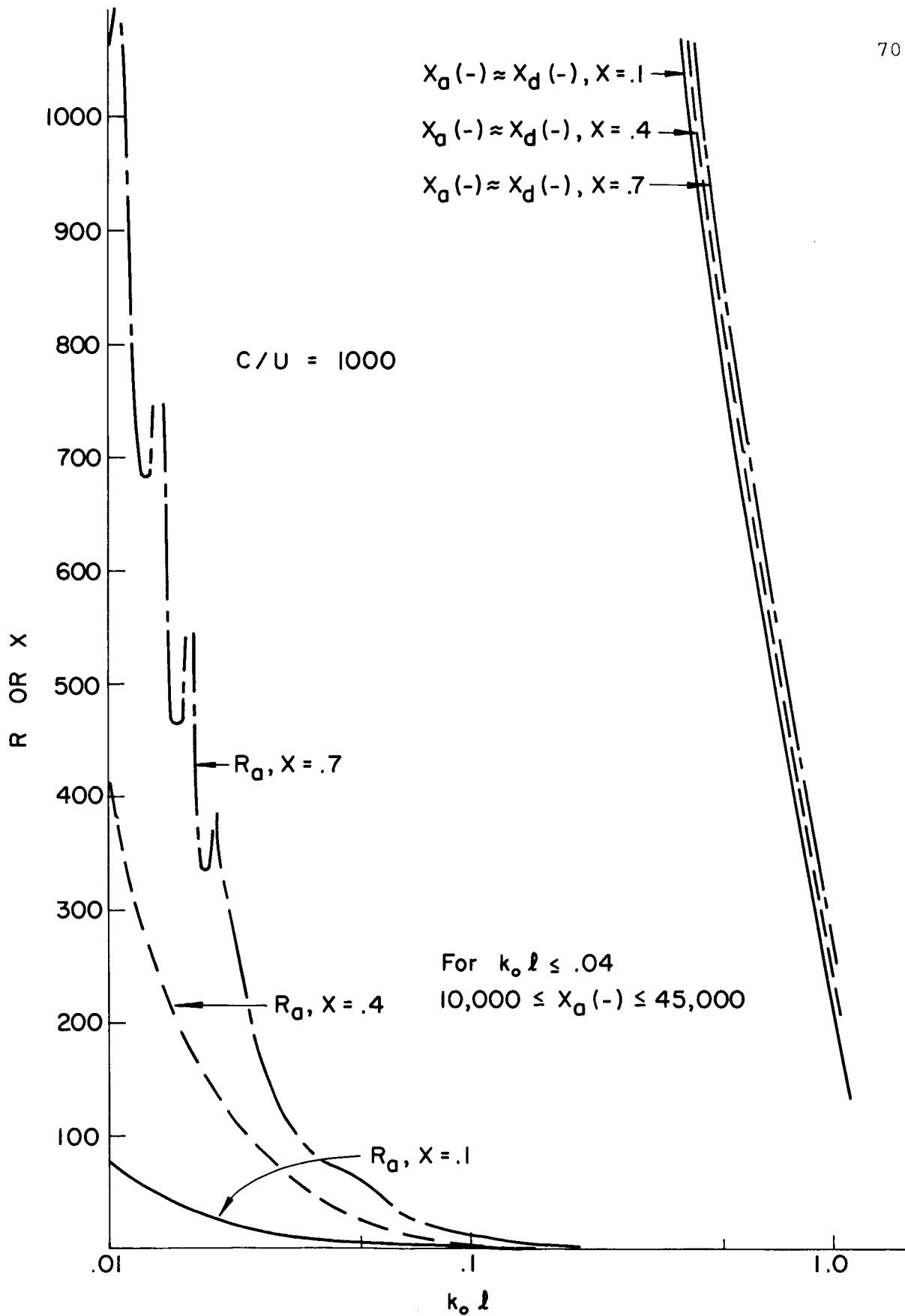

Figure 9. $Z_{in} = R_{a,d} + j X_{a,d}$ for a thin biconical antenna radiating into a warm plasma, $K = 500$ ohms

explicitly, Figures 10 and 11 were plotted. They are plots of $k^2 Y_t$ and Z_{in} versus c/u (which is equivalent to varying $k_p \ell$) for several fixed values of $k_o \ell$. For $k_o \ell = .02$ the maximum values of G_a/B_a ($\approx 1/3$) and R_a/X_a ($\approx 1/20$) occur for $c/u \approx 110$ or $k_p \ell \approx 1.20$. At $c/u = 1000$, $R_a/X_a \approx 1/70$ and $X_a \approx X_d$; hence, it appears as if acoustic waves will be negligible in this case for $c/u \geq 1000$. For $k_o \ell = .2$ the maximum values of G_a/B_a ($\approx 1/3$) and R_a/X_a ($\approx 1/20$) occur at $c/u \approx 11$ or $k_p \ell \approx 1.20$. In this case acoustic waves are negligible if $c/u \geq 100$. For $k_o \ell = 2$, the impedance exhibits acoustic effects only for values of $c/u \leq 10$. In conclusion it appears as if acoustic waves have a noticeable effect on impedance if $k_o \ell \leq .5$ and $.5 \leq k_p \ell \leq 10.$, as for a thin antenna $1/50 \leq R_a/X_a \leq 1/20$, over this range, $R_a \gg R_d$ and $X_a \approx X_d$.

As noted previously, the high characteristic impedance of a thin antenna may lead to a seemingly significant change in Y_t and no appreciable change in Z_{in} . Thus, it appears as if a wide angle antenna will be more sensitive to acoustic effects. This is indeed the case as Figures 12-18 indicate. The qualitative changes are the same, however. For the thin antenna the maximum value for R_a/X_a was approximately $1/20$. Figures 12 and 13 are for a wide angle antenna of half-angle $\theta_o = 66.06^\circ$. In this case for $X = .7$, $a = \ell$, maximum values of $G_a/B_a (>1)$ and $R_a/X_a (\approx 1/2)$ were obtained. As before, for values of $k_o \ell > .01$ increasing c/u from 100 to 1000 caused a decrease in acoustic effects. However, even for $c/u \approx 1000$, $R_a/X_a \approx 1/20$ for $k_o \ell = .01$.

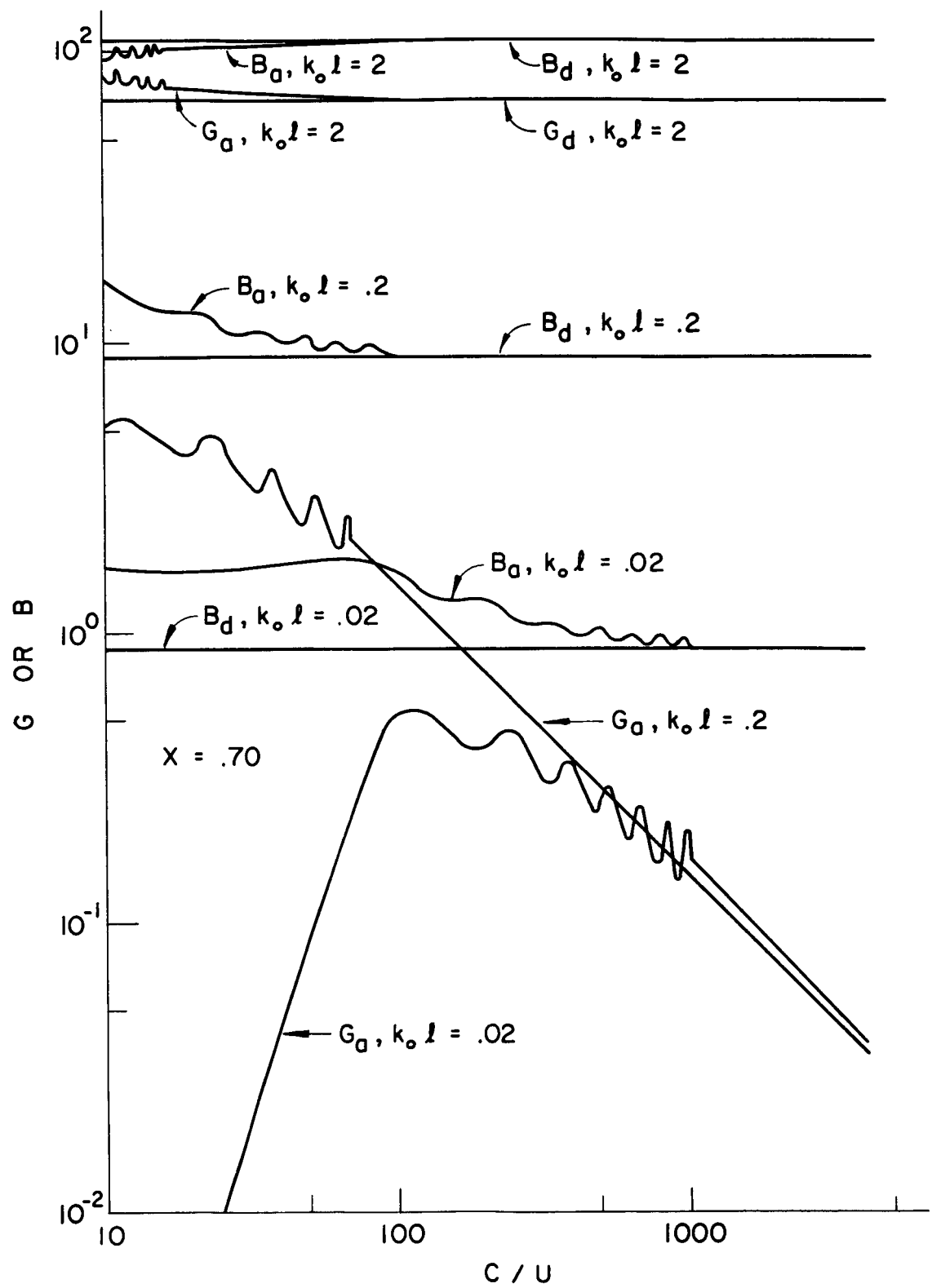

Figure 10. Effects of temperature (c/u) on $K^2 Y_t (G_{a,d} + j B_{a,d})$ for a thin antenna

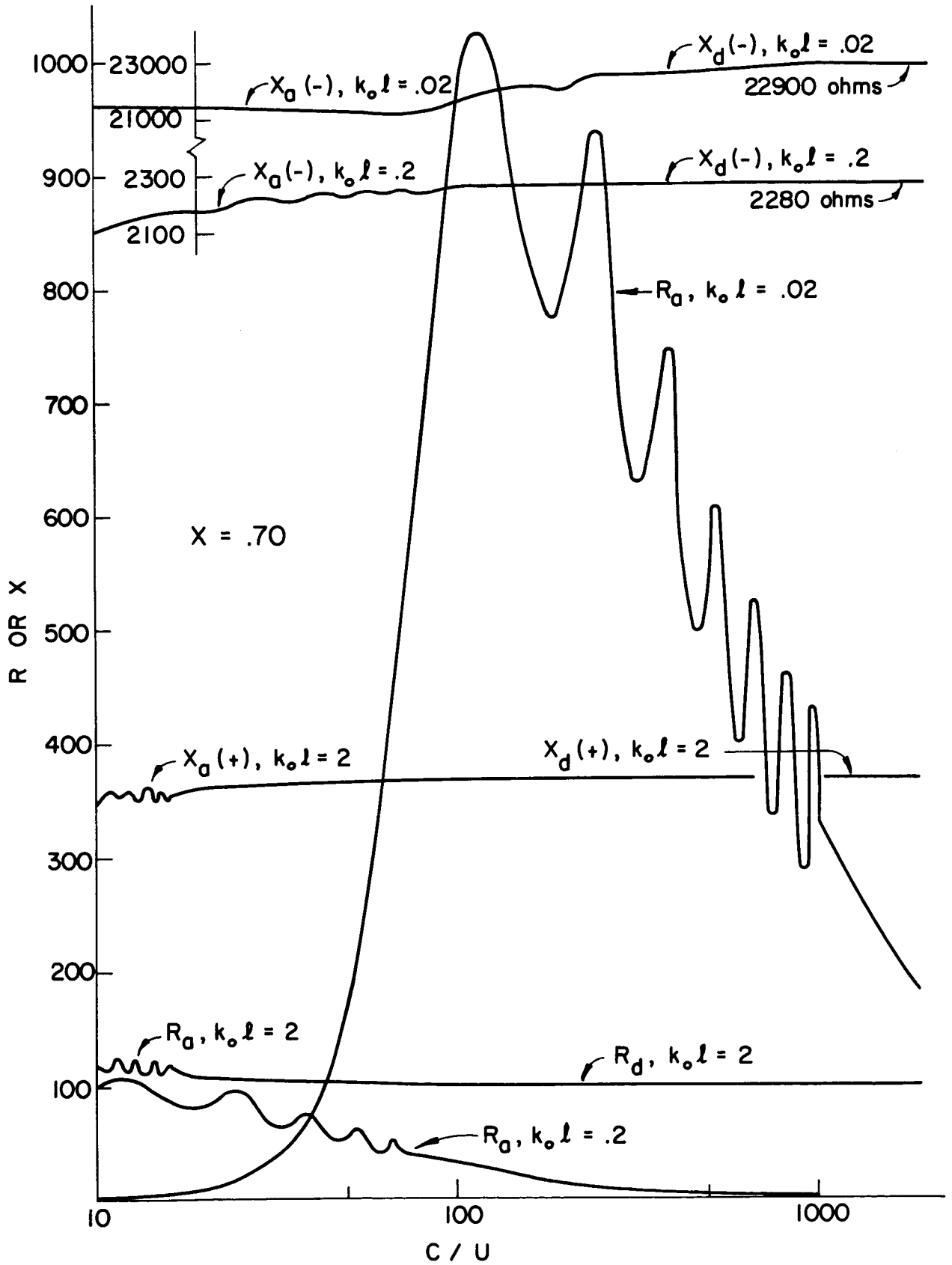

Figure 11. Effects of temperature (c/u) on $Z_{in} (R_{a,d} + j X_{a,d})$ for a thin antenna, $K = 500$ ohms

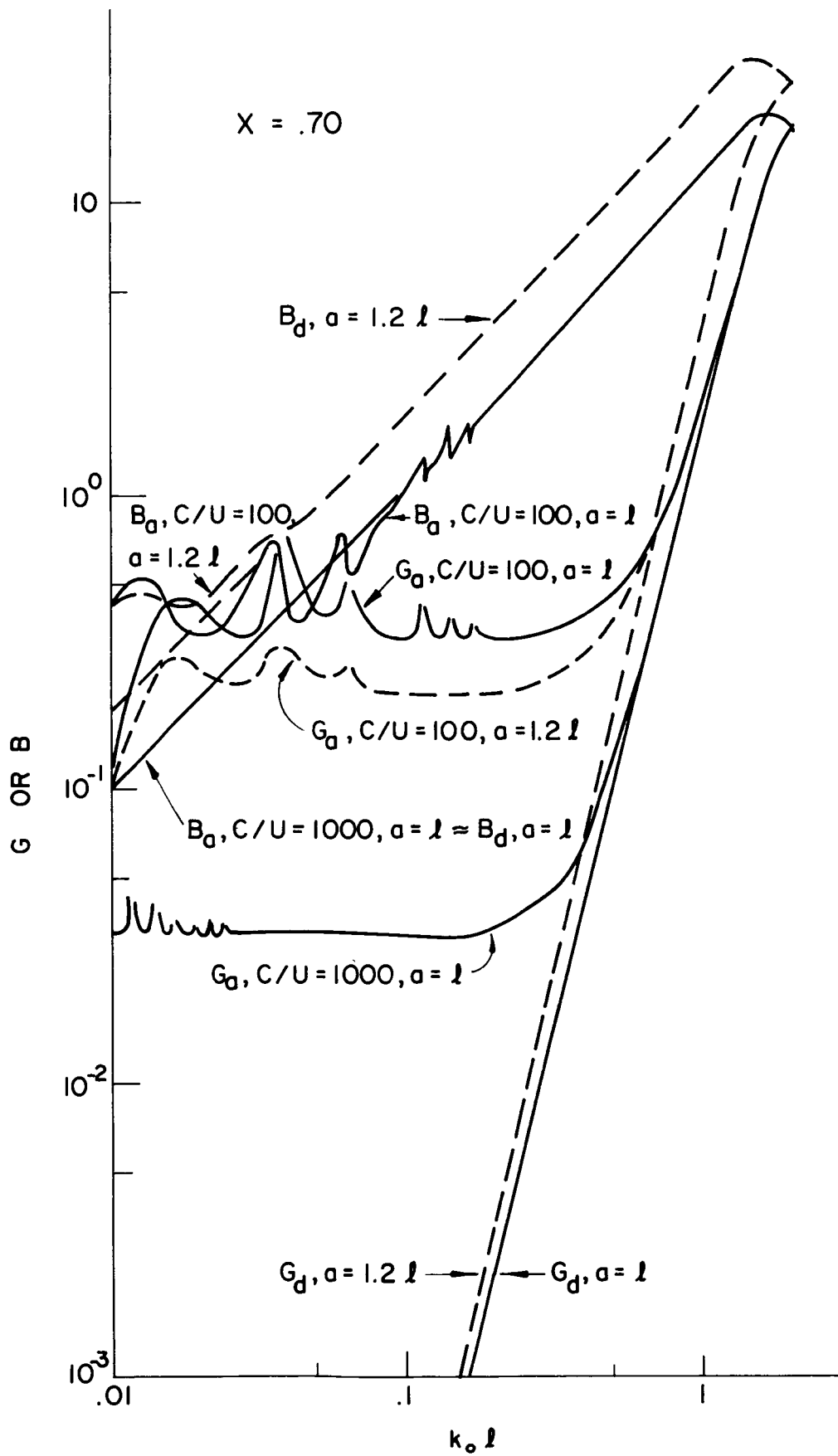

Figure 12. $K^2 Y_t = G_{a,d} + j B_{a,d}$ for a thick biconical antenna
 $(\theta_0 = 66.06^\circ)$ radiating into a warm plasma

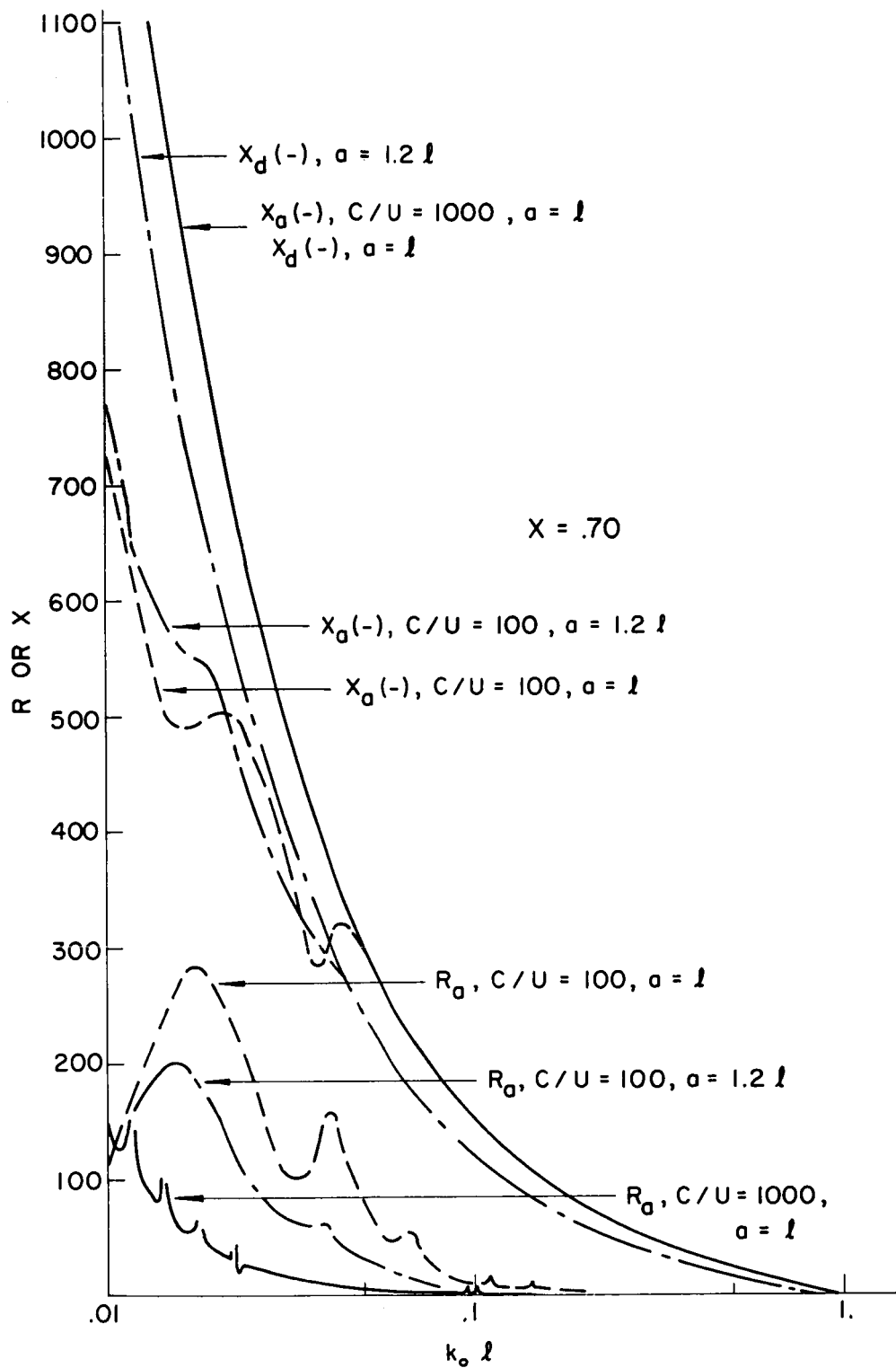

Figure 13. $Z_{in} = R_{a,d} + j X_{a,d}$ for a thick biconical antenna ($\theta_0 = 66.06^\circ$) radiating into a warm plasma

Figures 12 and 13 also show the effects of an ion sheath. The sheathed antenna ($a = 1.2 \ell$) has a lower G_a and R_a , indicating a decrease in the amount of acoustic power radiated. The curves are also smoother. Figure 14 contains more detailed information on sheath effects. 14 a,c,d indicate a reduction in R_a as the sheath size increases as do Seshadri (1965), Galejs (1966) and Wait (1964). In 14c an increase in sheath size causes X_a to approach X_d . 14b illustrates sheath effects for a case where acoustic waves are negligible. The effects are quite different in this case.

Figures 15 and 16 are similar to 10 and 11; however, acoustic effects are more pronounced. Note that acoustic waves also cause a quite noticeable change in X_a for certain parameter ranges. For $a = \ell$, $k_o \ell = .02$, $1/20 \lesssim R_a/X_a \lesssim 1/2$ if $50 \lesssim c/u \lesssim 1000$ or $.55 \lesssim k_p \ell \lesssim 11$. A similar curve plotted for $k_o \ell = .01$ (Figures 17 and 18) shows $1/20 \lesssim R_a/X_a \lesssim 1/2$ if $70 \lesssim c/u \lesssim 2000$. If $k_o \ell = .2$, the upper limit c/u in order for $R_a/X_a \gtrsim 1/20$ is $c/u \lesssim 100$. In conclusion it appears that there will be appreciable acoustic power radiated (i.e., $R_a/X_a \gtrsim 1/20$) if $.50 \lesssim k_p \ell \lesssim 10$ for this particular antenna.

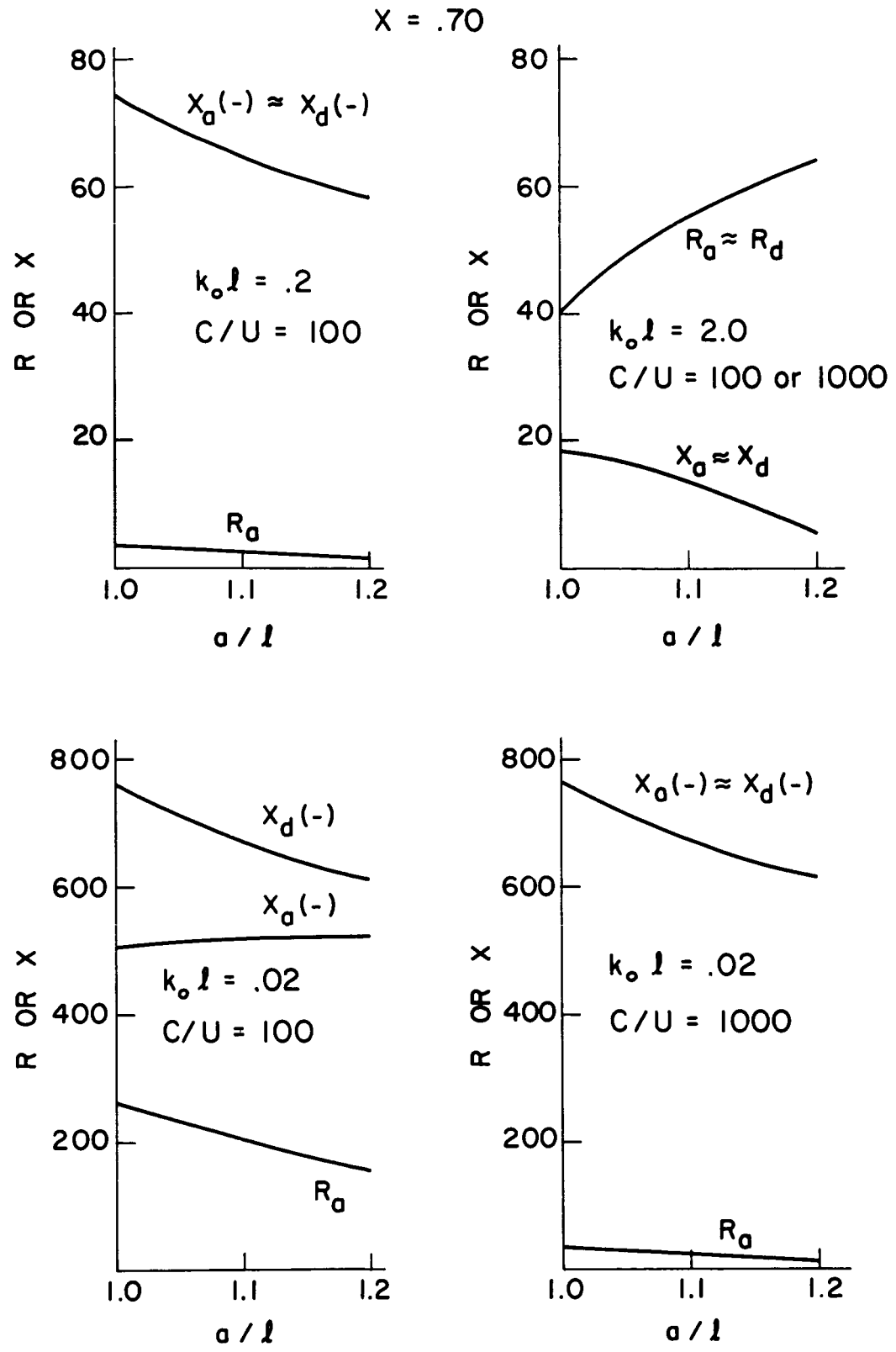

Figure 14. $Z_{in} = R_{a,d} + j X_{a,d}$ for a thick biconical antenna ($\theta_0 = 66.06^\circ$) radiating into an ion sheath and a warm plasma

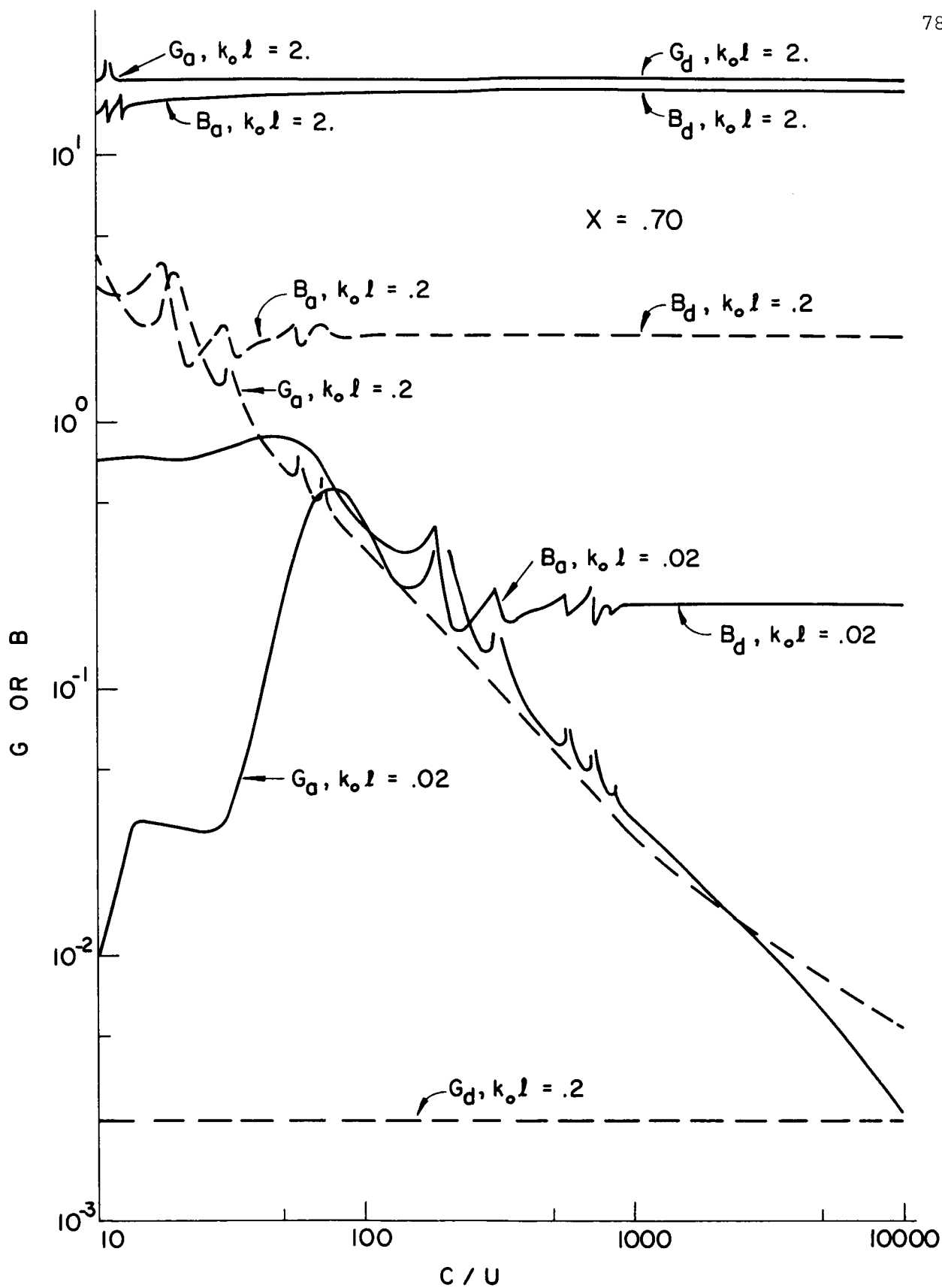

Figure 15. Effects of temperature (c/u) on $K^2 Y_t (G_{a,d} + j B_{a,d})$ for a thick antenna ($\theta_o = 66.06^\circ$)

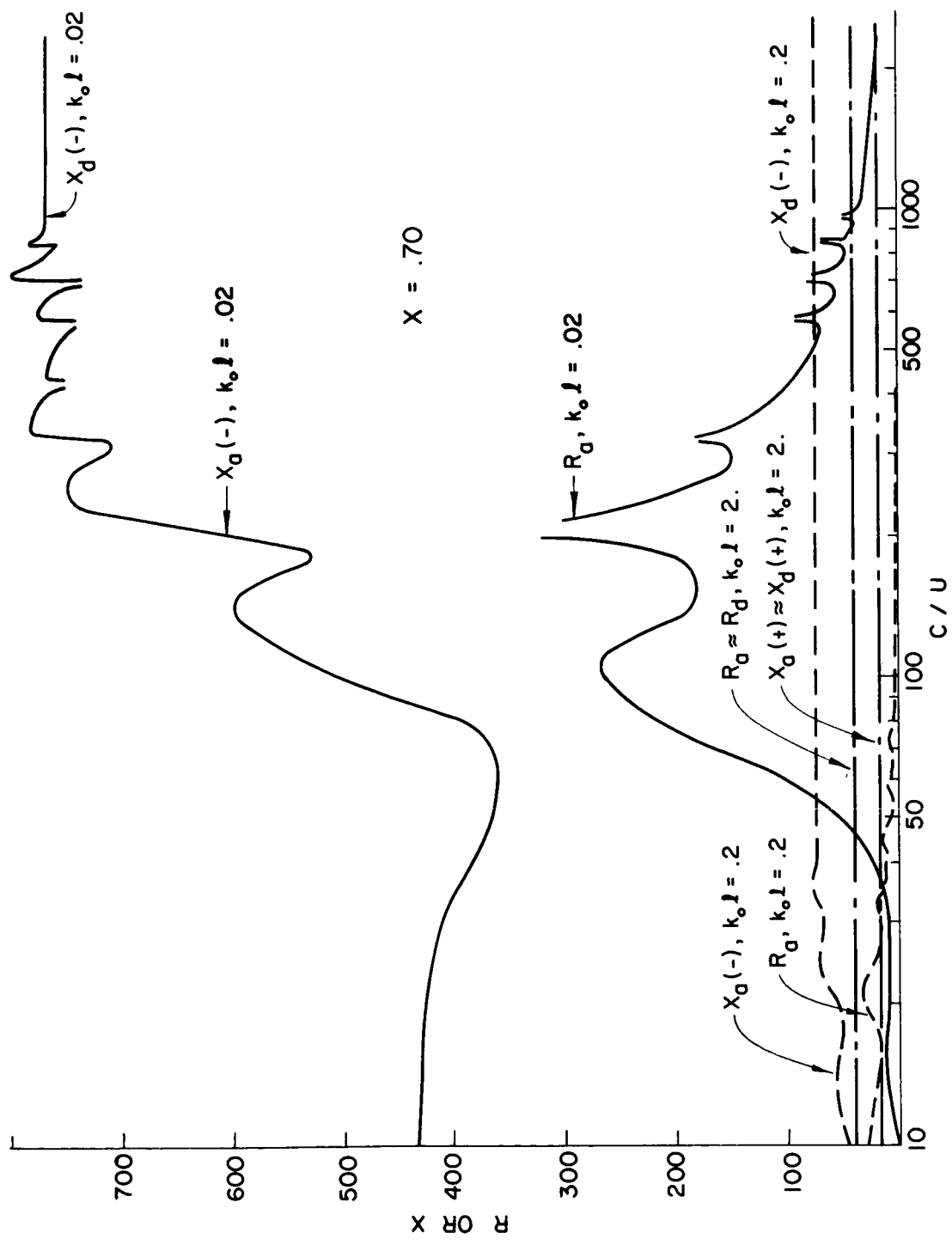

Figure 16. Effects of temperature (c/u) on Z_{in} ($R_{a,d} + j X_{a,d}$) for a thick antenna ($\theta_0 = 66.06^\circ$)

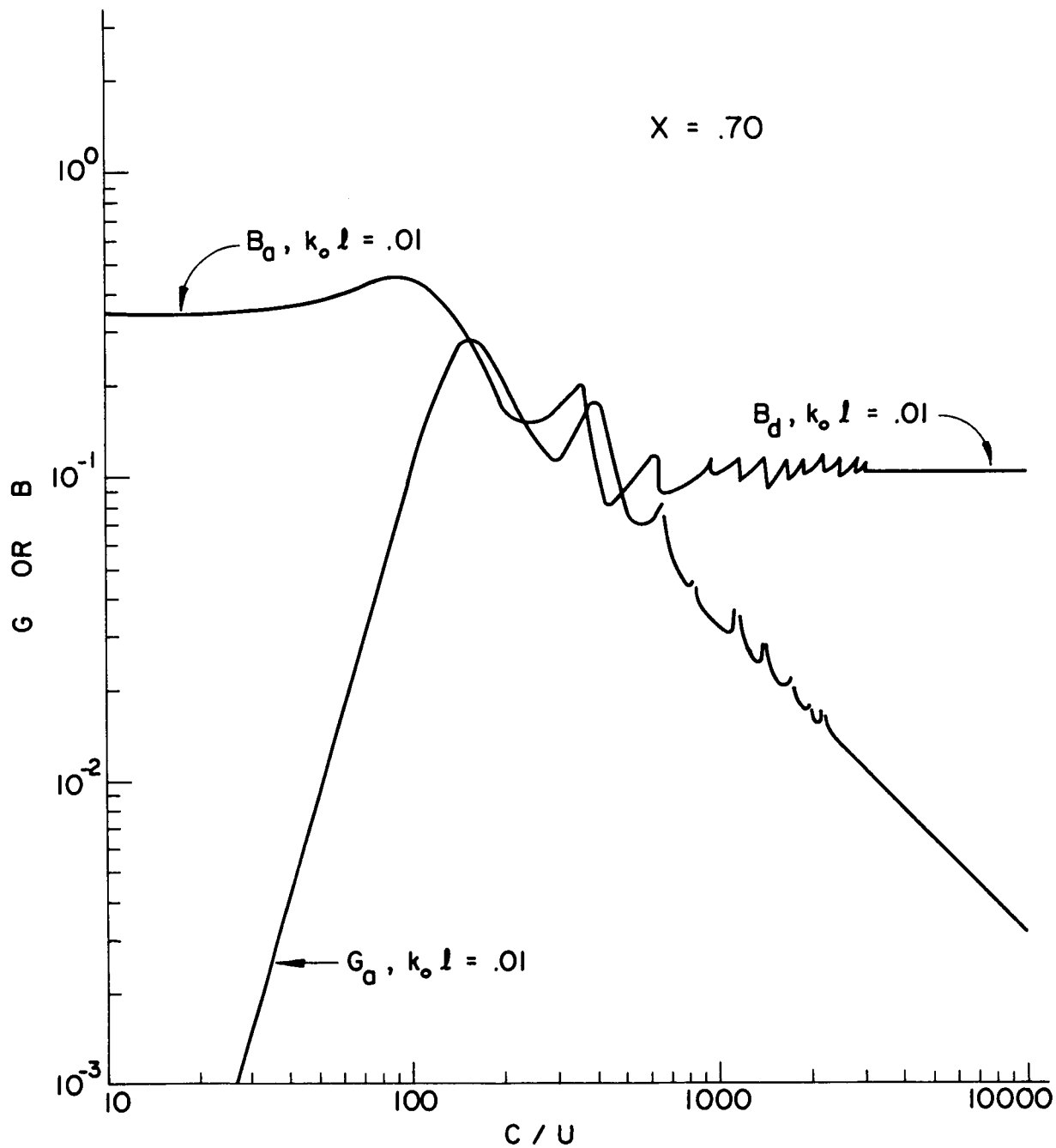

Figure 17. Effects of temperature (c/u) on $K^2 Y_t (G_{a,d} + j B_{a,d})$ for a thick antenna ($\theta_0 = 66.06^\circ$, $k_0 l = .01$)

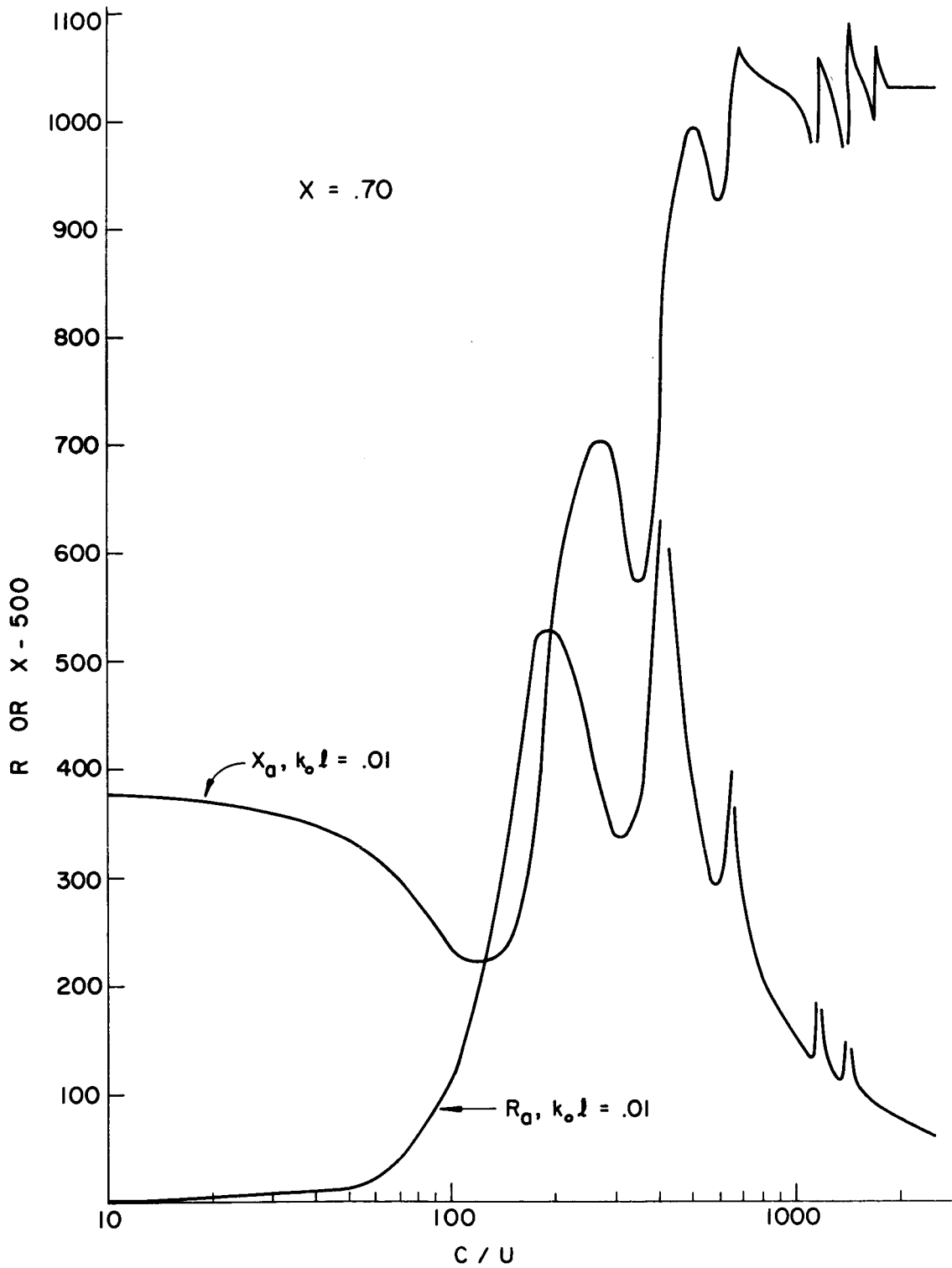

Figure 18. Effects of temperature (c/u) on Z_{in} ($R_{a,d} + j X_{a,d}$) for a thick antenna ($\theta_o = 66.06^\circ$, $k_o l = .01$)

IV. CONCLUSION

This work presents solutions for the impedance of some dipole antennas in a warm plasma. The effects of antenna size, plasma parameters, ion sheath size and induced acoustic sources at the antenna surface were investigated and extensive numerical results presented. A linearized hydrodynamic description was used for the plasma with temperature effects accounted for by a scalar isotropic pressure. The effects of collisions were neglected because of the resulting simplification in the numerical computations. However, this should cause little change in the overall effects of "plasma" waves on impedance; of course, it will change the quantitative results. The results, of course, are applicable only when the effect of collisions is small.

In Section 2, the effects of the induced acoustic sources along the surface of a cylindrical dipole on impedance were determined. To the best of this author's knowledge, these effects have not been previously investigated. A reciprocity theorem was derived for fields in a warm plasma. On assuming an impedance boundary condition ($\hat{n} \cdot \bar{v} = \alpha P$) at the antenna surface, a stationary formula was derived for the antenna impedance. The stationary quality of the expression is due to reciprocity. The primary benefit of this type of formulation is that one needs to only guess the functional form of the current and force distributions on the antenna surface as the expression is independent of relative magnitudes. If one attempts to use the "induced emf" method to compute impedance in a warm plasma, it would be necessary to specify both the functional form and the relative

magnitudes of the current and force distributions for a rigorous solution. As expected, neglecting the force term gives a result exactly the same as the "induced emf" method does if the current distribution is real.

The results obtained in Section 2 indicate that for the type of force distribution used, its effects on impedance are quite small. However, the "plasma" wave due to the assumed triangular current distribution had a marked effect on impedance in some cases. Even though the antenna was electrically short, it had an appreciable resistance in some instances because of the power radiated in the "plasma" wave. Broadly speaking, this occurred if $\omega > \omega_p$ and $.5 \lesssim k_p l \lesssim 40$. The imaginary part of the impedance was also affected as long as $k_p l \lesssim 40$ (or $\alpha_p l \lesssim 40$) if $\omega < \omega_p$. These results are quite consistent physically as a cold plasma corresponds to the limit $k_p l \rightarrow \infty$.

The stationary formulation yields no information about the induced sources. Due to the strong dependence of the impedance on the assumed form of the induced source distributions, a different antenna model was used for obtaining more detailed results. Section 3 contains an analysis for a biconical dipole. This antenna lends itself quite nicely to mathematical analysis in free space. It is possible to do the same in the case of a warm plasma if the antenna is encased in an insulating sphere of dielectric material. As such, this model appears to be feasible for experimental verification. This model is also a possible (albeit highly idealized) representation for the actual ion sheath formed about the antenna for a wide-angle bicone.

For this model it is relatively easy to expand the fields in the antenna and plasma region as a superposition of suitable "plasma" and "EM" modal solutions. Application of suitable boundary conditions yields a doubly infinite set of equations which are soluble in the limiting case of a very thin antenna. For wide-angle bicones an integral equation was derived for the tangential electric field in the antenna aperture. From this integral equation a variational expression was derived for the terminal admittance. In general, the impedance behavior of a biconical antenna in a warm plasma may be summarized by:

1. If acoustic effects are noticeable, they become more pronounced as the operating frequency of the antenna approaches the plasma frequency.
2. If $k_e l \ll 1$ and $k_p l \ll 1$, the input impedance is essentially reactive but may differ from that of the same antenna in an equivalent dielectric.
3. If $k_e l \gtrsim 2$, acoustic effects are negligible for $c/u \gtrsim 10$.
4. The occurrence of acoustic effects depends strongly on c/u (or $k_p l$) and $k_e l$. In general they affect the resistance significantly if $k_e l \lesssim 1$ and $.5 \lesssim k_p l \lesssim 20$, and the capacitance if $k_p l \lesssim 50$.
5. An increase in ion sheath size causes a decrease in R_a (also in the amount of acoustic power radiated).
6. Although acoustic effects appear to strongly affect Y_t , they may have no significant effect on Z_{in} if the characteristic impedance of the antenna is large.

It has been shown that "plasma" waves cause quite a marked change in antenna impedance. Induced acoustic sources, on the other hand, appear to have little effect on the impedance of a cylindrical dipole. However, it would be interesting to compute the impedance of a slotted sphere antenna by means of the variational formula derived in this work and observe the effect of the acoustic sources on impedance. In this case it appears as if they should have a noticeable effect. It also appears as if the variational techniques developed herein could also be applied to scattering problems in a warm plasma. Here it would also be of interest and importance to observe the effects of the induced acoustic sources on the scattered fields.

REFERENCES

- Abramowitz, M. and Stegun, I. A. (1965), Handbook of Mathematical Functions, Dover.
- Balmain, K. (1965), "Impedance of a Short Dipole in a Comprehensible Plasma," Radio Sci. J. Res. NBS, 69 D, 559-566.
- Chen, Kun-Mu (1964), "Interaction of a Radiation Source with a Plasma," Proc. Inst. of Elec. Engrs., (London), 111, 1668-1678.
- Cohen, M. H. (1961), "Radiation in a Plasma. Pt. I Cerenkov Effect," Phys. Rev., 123, 711-716.
- Cohen, M. H. (1962), "Radiation in a Plasma. Pt. II. Equivalent Sources and Pt. III. Metal Boundaries," Phys. Rev., 126, 389-404.
- Cook, K. R. and Edgar, B. C. (1966), "Current Distribution and Impedance of a Cylindrical Antenna in an Isotropic Compressible Plasma," Radio Sci., 1, 13-19.
- Fejer, J. A. (1964), "Interaction of an Antenna with a Hot Plasma and the Theory of Resonance Probes," Radio Sci. J. Res. NBS, 68D, 1171-1176.
- Field, G. B. (1956), "Radiation by Plasma Oscillations," Astrophys. J., 124, 555-570.
- Galejs, J. (1965), "Propagation along an Insulated Cylindrical Wire in a Compressible Plasma," IEEE Trans., AP-13, 644-645.
- Galejs, J., (1966), "Slot Admittance for Compressible Plasma Layers," Radio Sci., 1, 457-474.
- Harrington, R. F. (1961), Time Harmonic Electromagnetic Fields, McGraw-Hill.
- Hessel, A. and Shmoys, J. (1962), "Excitation of Plasma Waves in a Homogeneous Isotropic Plasma by a Dipole," Proc. Symposium on Electromagnetic and Field Dynamics of Gaseous Plasma, Polytechnic Press, Brooklyn, N. Y., 173-184.
- Jordan, E. C. (1950), Electromagnetic Waves and Radiating Systems, Prentice Hall.
- Kuehl, H. H. (1966), "Resistance of a Short Antenna in a Warm Plasma," Radio Sci., 1, 971-976.

- Rumsey, V. H. (1954), "Reaction Concept in Electromagnetic Theory," Phys. Rev., 94, 1483-1491.
- Schelkunoff, S. A. (1946), "Principal and Complementary Waves in Antennas," Proc. I.R.E., 34, 23-32.
- Schelkunoff, S. A. and Friis, H. T. (1952), Antennas Theory and Practice, John Wiley and Sons.
- Schelkunoff, S. (1952), Advanced Antenna Theory, John Wiley and Sons.
- Seshadri, S. R. (1965 a), "Radiation from Electromagnetic Sources in Plasma," IEEE Trans., AP-13, 79-88.
- Seshadri, S. R. (1965 b), "Radiation in a Warm Plasma from an Electric Dipole with a Cylindrical Column of Insulation," IEEE Trans., AP-13, 613-629.
- Seshadri, S. R. (1965 c), "Infinite Cylindrical Antenna Immersed in a Warm Plasma," IEEE Trans., AP-13, 789-799.
- Seshadri, S. R. (1965 d), "Propagation Coefficient for the Current Distribution along a Cylindrical Antenna Immersed in a Warm Plasma," Proc. Inst. Elec. Engrs., (London), 112, 877-882.
- Smith, P. D. P. (1948), "The Conical Dipole of Wide Angle," J. Appl. Phys., 19, 11-23.
- Tai, C. T. (1948), "On the Theory of Biconical Antennas," J. Appl. Phys., 19, 1155-1160.
- Tai, C. T. (1949), "Application of a Variational Principle to Biconical Antenna," J. Appl. Phys., 20, 1076-1084.
- Wait, J. R. (1964), "Theory of a Slotted-Sphere Antenna Immersed in a Compressible Plasma, Pt. I and II," Radio Sci. J. Res. NBS, 68d, 1127-1143.
- Wait, J. R. (1966 a), "Electromagnetic Radiation from an Acoustic Point Source within a Plasma Bubble," Can. J. Phys., 44, 467-475.
- Wait, J. R. (1966 b), "On Radiation of Electromagnetic and Electro-acoustic Waves in Plasma, Part II," Appl. Sci. Res., 12, 130-138.
- Wait, J. R. (1966 c), "On the Theory of Wave Propagation in a Bounded Compressible Plasma," Can. J. Phys., 44, 293-302.
- Wait, J. R. and Spies, K. (1965), "Theory of a Slotted Sphere Antenna Immersed in a Compressible Plasma, Pt. III," Radio Sci., 1, 21-26.

Weeks, W. L. (1958), "Dielectric Coated Spheroidal Radiators," Univ. of Ill. Antenna Lab. Tech. Report No. 34.

Whale, H. A. (1963), "The Excitation of Electroacoustic Waves by Antennas in the Ionosphere," J. Geophys. Res., 68, 415-422.

Whale, H. A. (1964), "Ion Sheath Effects near Antennas Radiating within the Ionosphere," J. Geophys. Res., 69, 447-455.

ADDITIONAL REFERENCES ON RELATED TOPICS

- Ginzburg, V. L. (1964), The Propagation of Electromagnetic Waves in Plasma, Pergamon Press.
- Hessel, A., Marcuvitz, N. and Shmoys, J. (1962), "Scattering and Guided Waves at an Interface between Air and a Compressible Plasma," IRE Trans., AP-10, 48-54.
- Oster, L. (1960), "Linearized Theory of Plasma Oscillations," Rev. Mod. Phys., 32, 141-168.
- Seshadri, S. R. (1964), "Radiation from an Electromagnetic Source in a Half Space of Compressible Plasma Surface Waves," Program Digest, IEEE Trans., AP-12, 340-348.
- Stix, T. H. (1962), The Theory of Plasma Waves, McGraw-Hill.
- Wait, J. R. (1964), "Radiation from Source in a Compressible Plasma Media," Can. J. Phys., 42, 1760-1780.