

NATIONAL AERONAUTICS AND SPACE ADMINISTRATION

Technical Report 32-1105

Surveyor Spacecraft Telecommunications

Charles Kirsten

FACILITY FORM 602

N67-23339
(ACCESSION NUMBER)

21
(PAGES)

CR-83553
(NASA CR OR TMX OR AD NUMBER)

(THRU)

1
(CODE)

07
(CATEGORY)

JET PROPULSION LABORATORY
CALIFORNIA INSTITUTE OF TECHNOLOGY
PASADENA, CALIFORNIA

March 15, 1967

NATIONAL AERONAUTICS AND SPACE ADMINISTRATION

Technical Report 32-1105

Surveyor Spacecraft Telecommunications

Charles Kirsten

Approved by:

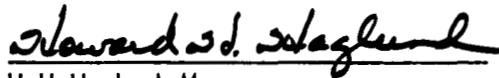

H. H. Haglund, Manager
Surveyor Project

JET PROPULSION LABORATORY
CALIFORNIA INSTITUTE OF TECHNOLOGY
PASADENA, CALIFORNIA

March 15, 1967

TECHNICAL REPORT 32-1105

Copyright © 1967
Jet Propulsion Laboratory
California Institute of Technology
Prepared Under Contract No. NAS 7-100
National Aeronautics & Space Administration

Abstract

Although the *Surveyor* program is approximately five years old, very little information concerning the on-board telecommunications has been published recently. Because much interest has been stimulated by the recent and very successful *Surveyor I* mission, it is believed that this descriptive JPL Report of the *Surveyor* telecommunications system will be of significant interest. The Report is oriented toward actual subsystem implementation and performance, rather than the purely analytical presentation.

Contents

I. Introduction	1
II. Basic System Capabilities.	3
III. Antennas	6
IV. Transmitters	7
V. Receivers	8
VI. Command Subsystem	9
VII. Signal Processing	11
VIII. Re-Design Requirements	15
A. High-Voltage Ionization	15
1. Transmitter design	15
2. RF diplexer design	15
B. Omnantenna Sticking	16

Tables

1. Spacecraft-to-Earth RF link	4
2. Surveyor modulation option	4
3. Telemetry and command data summary	5
4. Surveyor command format and coding	10
5. Amount of actuation per command	10
6. Surveyor typical telemetry measurements	12

Figures

1. Surveyor spacecraft A-21	2
2. Surveyor spacecraft A-21 telecommunication subsystem (compartment A)	3
3. Surveyor spacecraft A-21 telecommunication subsystem (compartment B)	3
4. Surveyor telecommunications subsystem	6
5. Surveyor telecommunications partial block diagram	6
6. Surveyor transmitter simplified block diagram	7
7. Surveyor receiver simplified block diagram	8
8. Surveyor command decoding block diagram	11
9. Surveyor simplified commutation and A/D functions	13
10. Surveyor simplified VCO and mixing functions	15

Surveyor Spacecraft Telecommunications

I. Introduction

Unlike previous spacecraft, such as the *Rangers* and *Mariners* which were designed to be as automatic as possible, the *Surveyor* spacecraft is not only completely controllable by ground commands but *must* be ground commanded to perform its mission operations. This fact may be better appreciated if it is realized that *Ranger VII* took 7,137 photographs of the lunar surface and was only commanded eleven times; whereas, the *Surveyor I* required 254 commands just to perform a normal transit to the moon (no pictures), and more than 100,000 commands were used during the lunar picture-taking operations. Although this philosophy of "fly by wire" is tremendously flexible, it places a great work load on the Space Flight Operations crews, and our experience during *Surveyor Mission A* showed that it was the endurance of the operational crews that was the limiting factor to continuous operation of the *Surveyor* spacecraft on the lunar surface, and not the reliability of the spacecraft itself.

The reliability of the *Surveyor* telecommunications system and the command subsystem in particular received much consideration during the design phases. Many

redundancies have been built into the telecommunications system, as can be seen by the following list of equipment on board:

2 omniantennas	2 command decoders
2 diplexers	8 subcommand decoders
2 receivers	3 commutators
2 transmitters	2 A-to-D converters
6 summing amplifiers	17 VCO's

Figure 1 shows the *Surveyor* spacecraft; the positions of the two omniantennas and the 27-db planar array antenna are indicated. The rest of the communication equipment is contained in the two thermally controlled compartments A and B, as indicated. These compartments are lined with an interior "super" insulation of 75 layers of mirror aluminum-coated one-quarter-mil mylar. This insulation proved extremely effective on the lunar surface, since one may think of it as 75 individual thermos bottles, one inside another. From a communications standpoint, it is significant, however, that these layers represent a labyrinth which traps air molecules so that these

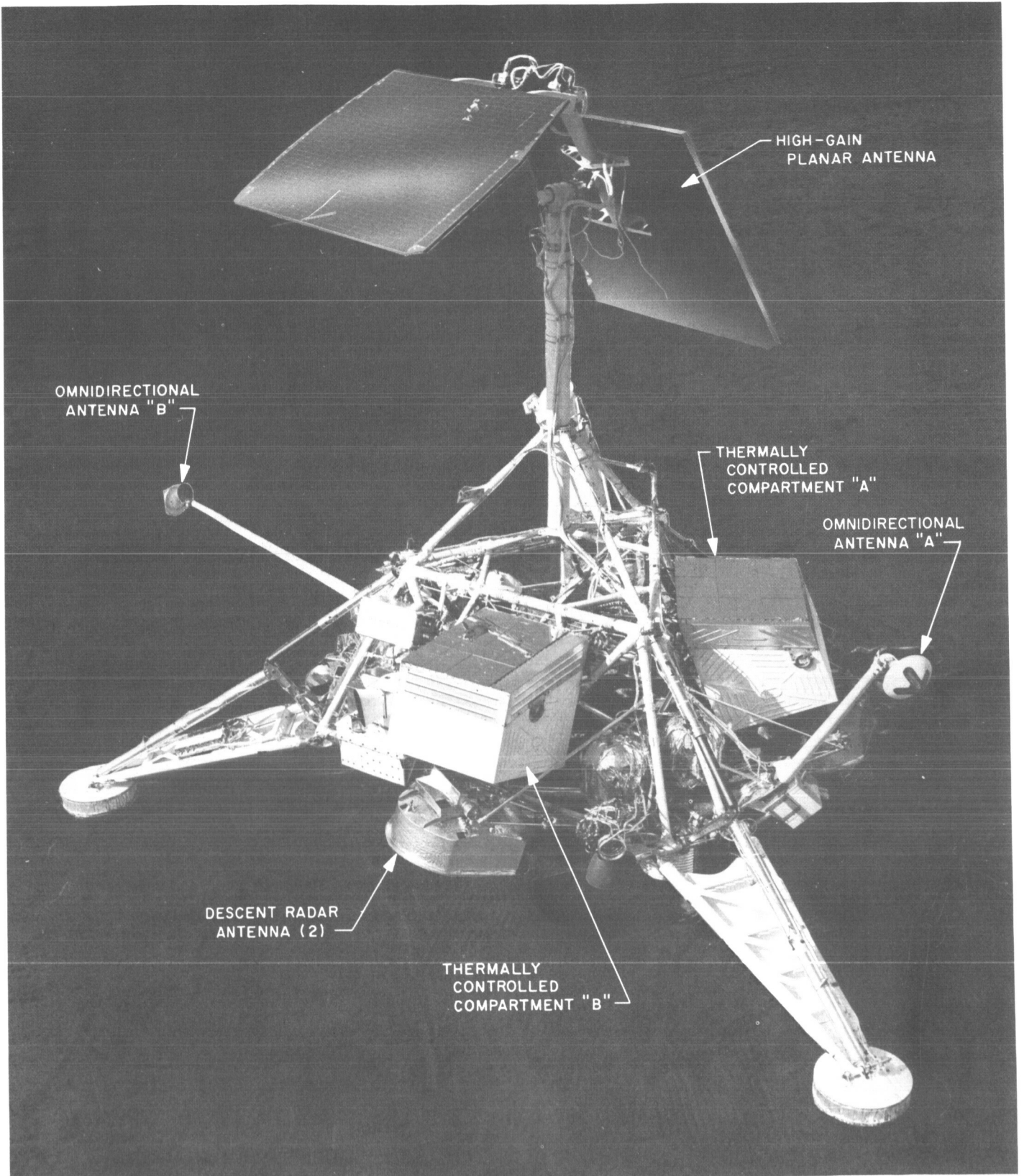

Fig. 1. Surveyor spacecraft A-21

boxes do not truly evacuate below a partial pressure which is critical to high-voltage breakdown for better than 48 hrs.

Figure 2 is an exploded view of compartment A, showing the positions held by transmitters A and B and the two receivers.

Figure 3 shows an exploded view of the positions held by the various command and signal processing equipment in compartment B.

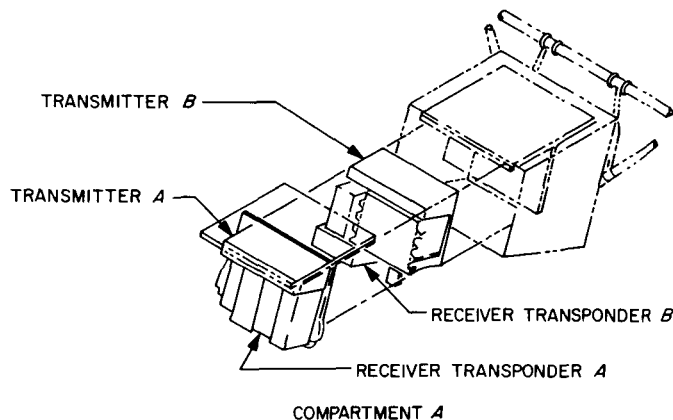

Fig. 2. Surveyor spacecraft A-21 telecommunication subsystem (compartment A)

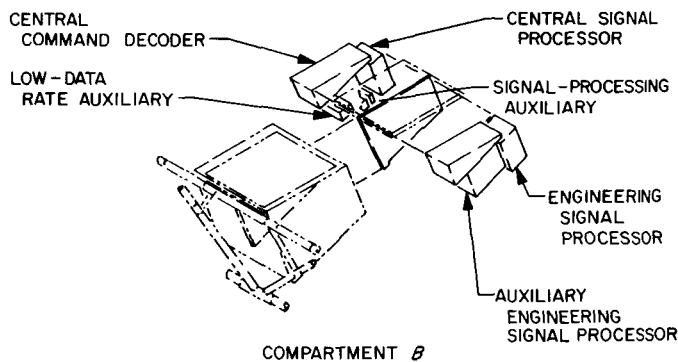

Fig. 3. Surveyor spacecraft A-21 telecommunication subsystem (compartment B)

II. Basic System Capabilities

One of the primary functions of the telecommunications subsystem is to provide phase-coherent two-way doppler for tracking and orbit determination. During the transit phase of the mission, this was provided by utilizing the transponder mode and the omnidirectional an-

tennas for transmitting and receiving. Phase-modulated telemetry is thus primarily used in transit. On the lunar surface, or in the case of a nonstandard event during transit, several other telemetry modes of operation are available.

The system is designed to be compatible with the Deep Space Instrumentation Facility (DSIF) operated by the Jet Propulsion Laboratory (JPL). The *nominal* RF link parameters are summarized in Table 1.

As can be noted, only the ground-receiver noise spectral density is shown for the spacecraft-to-Earth parameters. This is done because there exists such a variety of modulation modes in the down-link that a listing of modulation losses and bandwidth would become unwieldy.

For the up-link, it should be noted that both the carrier tracking and the command information channels are described. The spacecraft receiver can operate as a phase-lock receiver which is used for transponder operation during doppler tracking, requiring that the carrier channel parameters be analyzed separately. The command channel is PCM/FM, and the receiver operates as simply a standard FM/FM receiver independent of whether the receiver is RF phase-locked or in the AFC mode.

There are a number of modulation options for the Surveyor telemetry downlink, all of which are ground commandable; these are shown in Table 2 which also gives the command up-link modulation.

The analog/FM/FM data consist of wideband accelerometer data which are FM modulated on subcarriers and which are, in turn, FM modulated on the carrier. A special wideband voltage-controlled oscillator (WBVCXO) is used for this mode and also for 600-line television transmission (direct FM). The analog/FM/PM data consist of three strain-gage channels, used at touchdown to determine surface hardness and touchdown dynamics, a gyro speed channel, and a command-message enable/reject channel.

Finally, a back-up 200-line direct FM television mode is available. The 200-line television mode frequency-modulates a narrow band voltage-controlled crystal oscillator (NBVCXO). The main data transmission modes available thus have base-band frequencies ranging from 8 Hz for the low data rate PCM data to 120 kHz for the 600-line TV data. Detection noise bandwidths vary

Table 1. Spacecraft-to-Earth RF link

Parameters	Units	Parameters	Units	
Spacecraft (S/C) transmitted power	40.0 dbm or 20.0 dbm	Ground receiver noise:	{ -181.2 dbm/Hz (transit) -176.4 dbm/Hz (lunar)	
Losses	-4.0 db	Spectral density (55°K system temp in transit and 165°K system temp when viewing the Moon)		
S/C antenna gain	0.0 db omni, +27 db high-gain	DSIF transmitted power	70.0 dbm	
DSIF antenna gain (2295 MHz)	53.0 db	DSIF antenna gain (2213 MHz)	51.0 db	
Sum (equivalent transmitted power)	{ 89.0 dbm high-power omni 69.0 dbm low-power omni 116.0 dbm high-power, high-gain 96.0 dbm low-power, high-gain	S/C antenna gain	0.0 db	
Path loss (lunar distance)		-211.0 db	Losses	-4.0 db
Power at ground receiver		{ -122.0 dbm high-power omni -142.0 dbm low-power omni -95.0 dbm high-power, high-gain -115.0 dbm low-power, high-gain	Sum (equivalent transmitted power)	117.0 dbm
				Path loss (lunar distance)
			Power at the S/C receiver	-94.0 dbm
			Spacecraft receiver noise:	-164.0 dbm/Hz
		Spectral density (10 db noise figure)		
		Carrier modulation loss ($\beta = 1.6$)	-6.8 db	
		Carrier power	-100.8 dbm	
		Carrier noise bandwidth (240 Hz)	23.8 db	
		Carrier channel noise power	-140.2 dbm	
		Carrier signal to noise ratio	40.2 db	
		Command channel noise bandwidth (13 kHz)	41.1 db	
		Command channel noise power	-122.9 dbm	
		Command channel signal-to-noise ratio	28.9 db	

Table 2. Surveyor modulation option

Linkage	Type modulation	Information bandwidth	bits/sec	Data uses	
Down Link 	PCM/FM/PM	8 Hz to 2.25 kHz	Selectable*	11 bit PCM engineering data during two-way doppler track and for one way acquisition	
	PCM/FM/FM	225 Hz to 2.25 kHz	Selectable*	11 bit PCM engineering data during one-way track (no command capability)	
	Analog/FM/PM	80 Hz	—		shock absorber strain gages
		55 Hz	—		gyro speeds
		50 Hz	—		command message reject/enable
	Analog/FM/FM	1 kHz	—		wide-band accelerometers
	Direct FM	220 kHz	—		600 line TV (wide-band XTAL VCO)
1.2 kHz		—		200 line back-up TV (narrow band XTAL VCO)	
Up Link	PCM/FM/PM	8-48 Hz	48	24 bit commands	

*Selectable by ground command as 4400, 1100, 550, 137.5, 17.2 bits/sec.

from 25 Hz to 3.3 MHz for the above-mentioned channels.

The majority of the engineering telemetry information is transmitted as commutated PCM data. Two main commutators are utilized with each commutator having nearly the same signals. A total of six modes of engineering telemetry is available through these commutators. These modes are selected during specific mission phases, and thus contain data pertinent to that phase.

In addition to the two basic commutators, a special commutator is used during television transmission to transmit pertinent TV data between TV frames.

All of these various options and operational modes require a very wide command repertory, since very few of them are commanded by on-board logic.

Table 3 gives a numerical summary of both the telemetry measurements and the commands associated with each subsystem, by arbitrary categories. It may be noticed that the command subsystem is conspicuous by its absence. It happens to be the only subsystem which is not particularly switchable or telemetered. Obviously, it is possible to avoid addressing portions of it which may have malfunctioned, and the command capability is such that many actions may be simulated in several different ways.

Figure 4 shows an extremely simplified block diagram of all of the telecommunications equipment. Unfortunately, it is not possible to indicate all the various interrelationships without making an impossibly complicated diagram. In order to discuss the various equipment operations, portions of the system will be examined separately in this Report.

Table 3. Telemetry and command data summary

A. Telemetry data summary

Parameters	RF link	Signal proc.	Flt. contr.	Pwr.	Propulsion	Radar	Vehicle & mech.	TV	All
Physical position	3* (Planar)	—	—	4* (Panel)	—	—	7	6	13
Accel/strain	—	—	2	—	3	—	11	—	16
Pressure	—	—	1	1	2	—	—	—	4
Temp.	2	—	9	5	16	7	33	6	78
Volts	8	2	22	12	—	10	—	3	57
Current	—	2	—	12	—	1	—	—	15
Binary "on-off"	8	3	28	3	—	19	11	6	78
Total	18	7	62	33	21	37	62	21	261

*Redundant listing to that in mechanisms.

B. Command data summary

Parameters	RF link	Signal proc.	Flt. contr.	Pwr.	Propulsion	Radar	Vehicle & mech.	TV	All
Physical movement	6* (Planar)	—	—	8* (Panel)	3	—	16	18	37
Switching	22	54	20	14	6	7	2	9	135
Thermal control	—	—	—	—	9	2	6	7	24
Total	22	54	20	14	18	9	24	34	195

*Redundant listing to that in mechanisms.

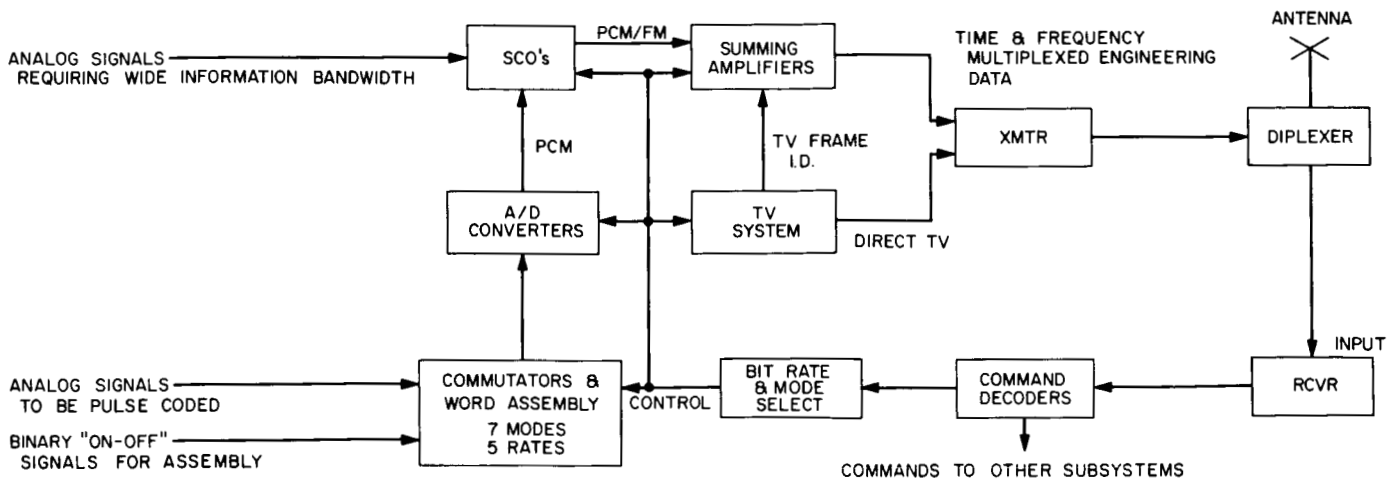

Fig. 4. Surveyor telecommunications subsystem

III. Antennas

Figure 5 shows the manner in which the omni antennas, diplexers, and receivers are interconnected with the transmitters. As can be seen, the input of each receiver is always connected to one of the omni antennas, but the transmitters may be switched from high-gain to omni.

One transmitter or the other is always connected to the high-gain antenna, leaving the remaining transmitter output connected to the selected omni antenna.

The planar array has a 27-db gain above isotropic, and a beam width of approximately 6 deg. The high-gain

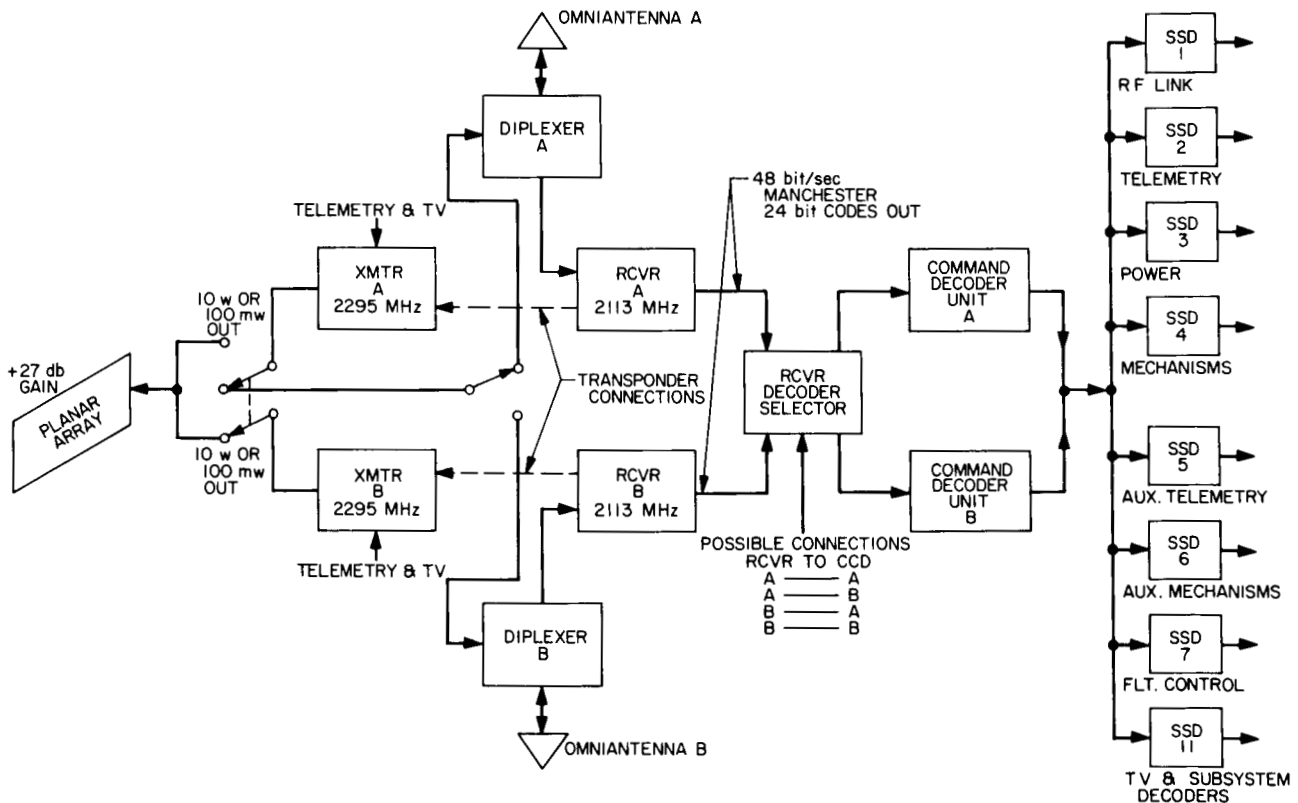

Fig. 5. Surveyor telecommunications partial block diagram

antenna is used for transmitting only, so it operates only at 2295 MHz.

The omniantennas have patterns which may be visualized as cardioids of revolution with the null centered back along the antenna support in the direction of the spacecraft. Thus, both antennas are required to give a full 4π steradian coverage at near 0-db gain. However, proper maneuvering of the spacecraft can avoid the necessity for switching the omniantennas, as was ably demonstrated on *Surveyor I* when omniantenna A failed to deploy, and the mission was flown using just omniantenna B.

IV. Transmitters

Except for the traveling-wave-tube (TWT) power amplifier in the transmitters, the telecommunications system is entirely solid state. RF switching is accomplished by electromechanical relays, but all power control is

accomplished with silicon controlled rectifiers and solid state switches.

Figure 6 is a simplified functional block diagram of the transmitter which operates in the "S" band at 2295 MHz. The transmitter may be used in conjunction with the receiver in the transponder mode by receipt of a signal phase lock dc and RF from the receiver. The dc removes the transmitter crystal frequency, and the receiver 19 MHz RF is used to control the narrow-band voltage controlled oscillator output. In this mode, the transmitter can only accept phase-modulated telemetry.

The transmitter has a maximum output of 10 w, but the TWT may be turned off and bypassed, and transmission made solely on the solid state 100-mw transmitter. An interlock feature has been included on the TWT filament such that high voltage cannot be applied to the TWT unless the filaments are first energized. When energized, the filament voltage inhibits the signal processing for the opposite transmitter so that both transmitters

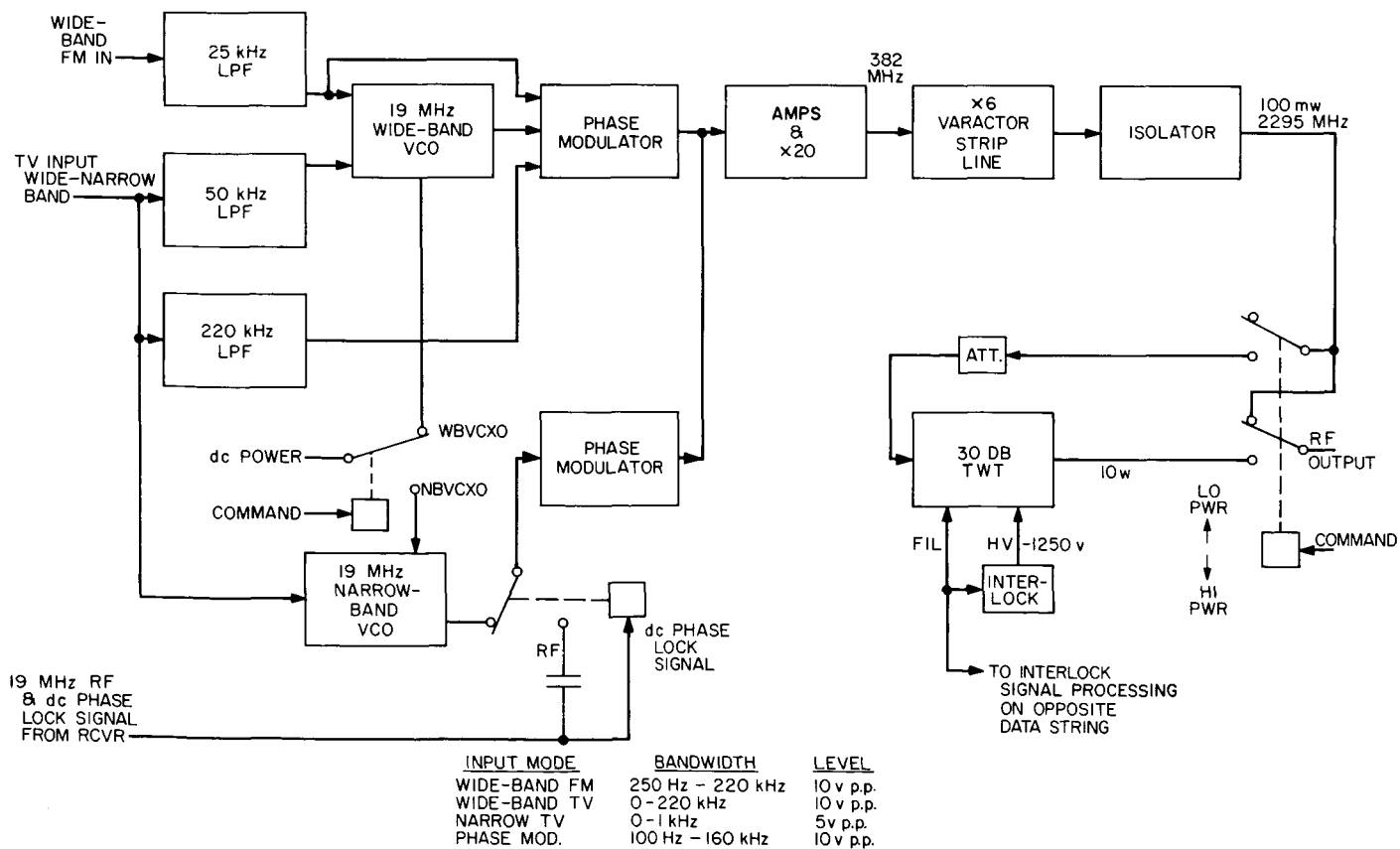

Fig. 6. Surveyor transmitter simplified block diagram

cannot be modulated simultaneously if one of the transmitters is in high power. Normal one-way transmission bandwidth capability is 220 kHz, and normal two-way lock on narrow band is 160 kHz.

V. Receivers

Figure 7 is a simplified functional block diagram of the receiver. The *Surveyor* receiver is a double superheterodyne which operates at 2113 MHz, and contains a command subcarrier discriminator so that its output is directly in PCM commands.

The input 2113 MHz is directly mixed in a cavity mixer with a 1066 MHz reference, giving a 47 MHz first IF frequency. The reference is derived from the basic 19 MHz local oscillator by a four-stage multiplier of three successive harmonic multipliers, which multiply the signal to 344 MHz. It is low-pass filtered, power amplified, and drives a times 6 varactor cavity multiplier to attain the 1066 MHz.

After mixing, the resultant 47 MHz intermediate frequency is filtered and amplified by three successive stages before being applied to the second mixer. Here, the 47 MHz signal is mixed with a 38 MHz reference, which is derived from the local oscillator by a times 2 multiplier.

The resultant 9.6 MHz second IF frequency is amplified, crystal filtered, and amplified in three more stages. Automatic Gain Control is derived by detecting the 9.6 MHz signal level at the output of the amplifier. The signal is hard-limited before going to the IF discriminator, and the limited 9.6 MHz output is also used as a reference for both the automatic phase control detector and the quadrature phase detector which is used as described below.

The 9.6 MHz discriminator output is the command subcarrier frequency and a dc component. The dc is amplified and then used as an automatic frequency control over the 19 MHz local oscillator. The subcarrier drives the command subcarrier frequency discriminator. The

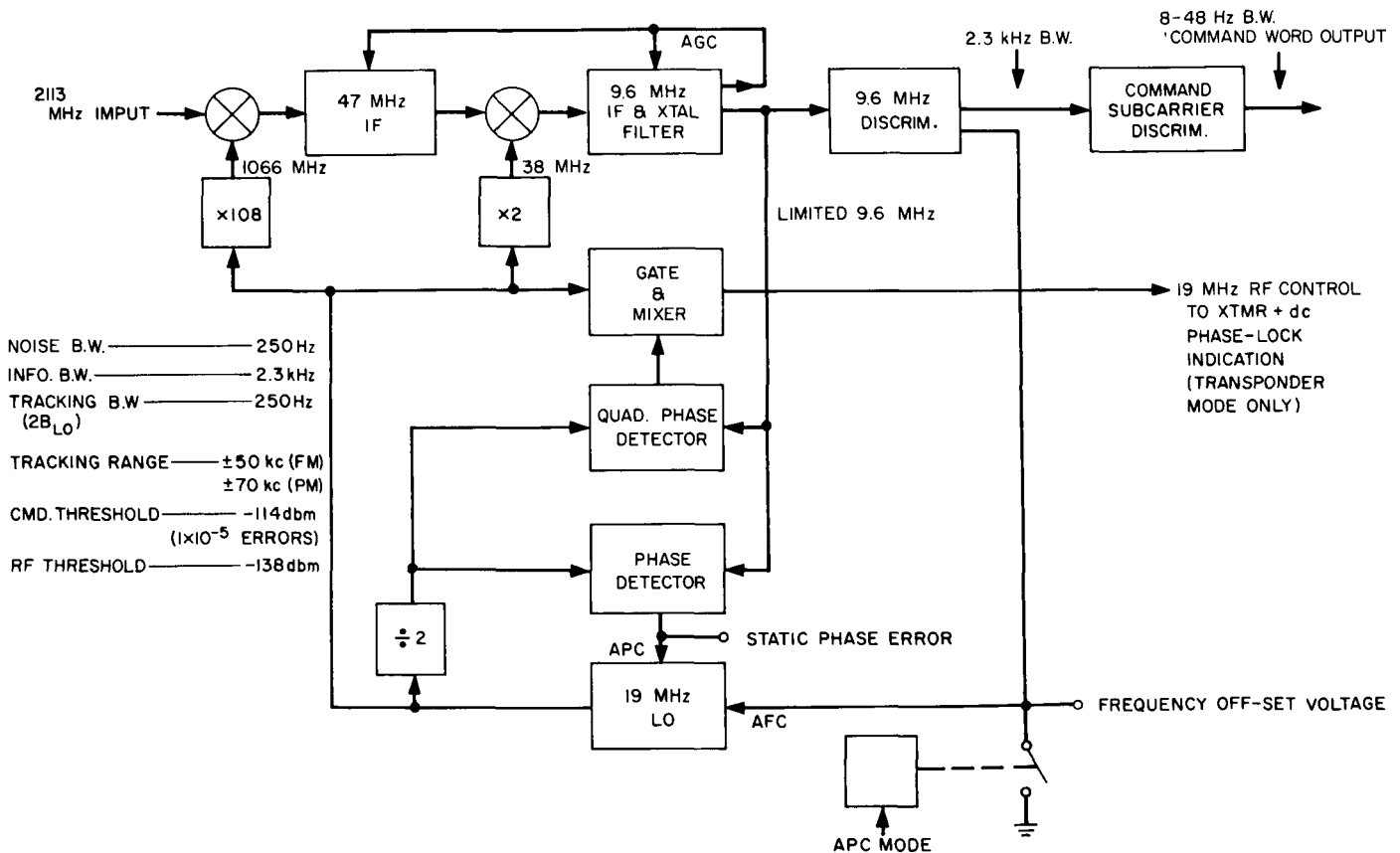

Fig. 7. Surveyor receiver simplified block diagram

command subcarrier discriminator has post amplification and pulse shaping to give usable bit outputs directly to the Central Command Decoder. Determination of which receiver output to use for accepting commands is accomplished external to the receivers in the Receiver Decoder Selector, which will be described in the command subsystem discussion.

The use of the quadrature phase detector, whose output goes to dc positive when phase lock is accomplished (note that the in-phase detector which controls the local oscillator attempts to reduce its output to zero), is to gate the receiver local oscillator frequency to the transmitter only when phase lock on the received signal from the ground has been accomplished. Thus, as soon as phase lock is lost, the transmitter is returned to crystal control by inhibition of the receiver RF output, and by ungrounding the internal VCO output. Conversely, when phase lock is accomplished, a $7\frac{1}{2}$ mw RF signal at 19 MHz is applied from the receiver to the transmitter, and on the same line a dc voltage performs the function of grounding the transmitter narrow band VCO output, putting the receiver-transmitter combination in the transmitter mode.

VI. Command Subsystem

The command subsystem is the heart of the *Surveyor* capability, since so many of the capabilities of the spacecraft cannot be realized without direct intervention by ground command. Even such actions as midcourse maneuvers must be accomplished by successive commandings of the roll, yaw, and pitch attitudes, since there is only one commandable magnitude storage register aboard the spacecraft. In consequence, elements of the command subsystem may be found in every other major subsystem aboard the spacecraft.

The distribution of command information has been facilitated by providing eight subsystem command decoders, each of which is physically located in or near its associated subsystem and which is addressed individually by the Central Command Decoder according to the received command.

Figure 5 illustrates the receiver, command decoder unit, and subsystem decoder arrangements. Again in the interest of reliability, the two receivers may be switched individually to drive either one of the Command Decoder Units. This is accomplished automatically by the Receiver Decoder Selector whenever there is loss of the command

subcarrier into the receiver. The switching order is successive and connects the receivers and decoders as follows:

- (1) Receiver A to Command Decoder A.
- (2) Receiver A to Command Decoder B.
- (3) Receiver B to Command Decoder A.
- (4) Receiver B to Command Decoder B.

It is apparent that with these possible options, command capability can be retained even if there is a failure of one of the receivers and one of the command decoders.

Table 4 gives an illustration of the manner in which the commands are designated by octal numbers, and an example of a typical command with the associated octal, binary and code waveform. The command format is a 24-digit word using Manchester coding. The first four bits are used for synchronization and to identify the beginning of a command word. The next ten bits comprise the address and address complement of the desired subsystem decoder. The address is sensed in the Command Decoder Unit (CDU), and complementation is examined on the entire word. The last ten bits comprise the instruction to the subsystem decoder (SSD) for the desired command to be implemented.

Table 4 also lists the major areas of control associated with the various SSD addresses. (This is also shown schematically in Fig. 5.)

Figure 8 shows a simplified block diagram of the command system logical arrangement. Incoming commands are examined, six digits at a time, in a 6-digit shift register which provides voltages corresponding to the bits in a diode matrix. The other coordinate of the matrix is driven by two three-bit registers which are under the control of a bit and word count from the clock pulse generator. The result is a clocked examination of the commands, six bits at a time, for complementation and subsystem address.

As can be seen, all subsystem decode matrices are enabled with a time delayed signal to permit the command scan. All subsystem decoders, except the one addressed, are inhibited from acting on the command.

The proper SSD requires both the absence of an "off" command and the presence of *address enable* and *command enable* before its diode matrix is energized to decode the command. Not shown is a universal anti-noise

Table 4. Surveyor command format and coding

Function		Sync.	Address complement				Address				Command complement				Command										
Fixed values		0 — — 1																							
Octal digits		Special	Address complement				1st Digit	2nd Digit	Command complement				3rd Digit	4th Digit											
Sensed by CCD		√ √ √ √	√ √ √ √ √	√ √ √ √ √	√ √ √ √ √	√ √ √ √ √	√ √ √ √ √	Complement check only																	
Sensed by SSD			√ √ √ √ √	√ √ √ √ √	√ √ √ √ √	√ √ √ √ √	√ √ √ √ √	√ √ √ √ √	√ √ √ √ √	√ √ √ √ √	√ √ √ √ √	√ √ √ √ √	√ √ √ √ √	√ √ √ √ √	√ √ √ √ √	√ √ √ √ √									
Sample: 0601- "extend omnis"	Octal	Special	3	1	0	6	3	6	0	1															
	Binary	0 — — 1	1 1 0 0 1	0 0 1 1 0	1 1 1 1 0	0 0 0 0 1																			
	Code																								
	CCD	Sync.	Check complement				Select SCD No. 6				Complement check only														
	SCD	—	Confirm address				Confirm address				Select "extend omni"														
Bit position		1	2	3	4	5	6	7	8	9	10	11	12	13	14	15	16	17	18	19	20	21	22	23	24
Summary of sub-system decoder functions by address:																									
01XX—RF system & approach TV 02XX—Telemetry control 03XX—Power sub-system control 04XX—Mechanisms operation 05XX—Telemetry control												06XX—Mechanism & radar 07XX—S/C flight functions 11XX—Lunar television 3617—Special interlock 0000—Fill-in command													
Quantitative commands are address O0XX after the interlock																									

biasing on all gates and flip-flops to prevent loading and noise triggering.

Some of the critical commands, associated with squib firings and other irreversible actions, are interlocked, so that they will not be recognized or acted upon unless the command subsystem has first received the special interlock command (Octal 3617). This interlock is also used as a protection on the magnitude command register, which has a 0000 octal address after receipt of the interlock command. The reason for this provision was the feeling that the magnitude command register needed additional protection, since it might often be required to hold magnitudes for long periods of time without change. The interlock is more a protection against system noise disturbances than anything else, since the inserted magnitude is always retransmitted to Earth via telemetry to determine that the proper value is inserted.

Some sense of the command requirements may be obtained by examining the actuations effected by some of the commands. Each command effects the amount of actuation per command as listed in Table 5.

Table 5. Amount of actuation per command

Command	Function	Actuation, deg
0401	Step solar panel down	1/8
0403	Step solar axis clockwise	1/16
0405	Step roll axis	1/8
1115	Step mirror right	3
1122	Step mirror up	2.5

Obviously, many commands must be sent to cause appreciable rotations of these devices and, to facilitate this, multiple command tapes are prepared for use by the ground-control crews long before flight. Not only are the commands made in multiple steps, but long sequences of commands have been prepared to accomplish various required maneuvers and actuations.

Since there may be 32 commands associated with each subsystem decoder, there are 256 direct commands possible, and also 1,024 values may be inserted in the quantitative command register.

Table 6. Surveyor typical telemetry measurements

Data link		Digital words*	Commutator word addresses						SCO Freq.
			ESP modes				AESP modes		
Channel	Measurement		1	2	3	4	Cruise	Thrust	
D-1	Omni A transmitted pwr.				1	87			
D-2	Xmtr A filament on	6, 10 (5)							
D-3	Omni B transmitted pwr.				11	117			
D-4	Xmtr B filament on	6, 10 (6)							
D-5	Xpndr A phase locked	6, 10 (3)							
D-6	Xpndr B phase locked	6, 10 (4)							
D-7	Static phase error A				3, 23, 43, 63, 83	17			
D-8	Static phase error B				13, 33, 53, 73, 93	27			
D-9	Receiver A AGC				5, 25, 45, 65, 85	31			
D-10	Receiver B AGC				15, 35, 55, 75, 95	33			
D-11	Command message reject	5, 6, 10, 12 (2)						2.3 kHz	
D-12	Central Decoder A on	6, 10 (8)							
D-13	Xmtr A temp.					10	10		
D-14	Xmtr B temp.	5, 6, 10, 12 (1)				30	30		
D-15	Message enable							2.3 kHz	
D-16	Receiver A AFC					37			
D-17	Receiver B AFC					41			
D-18	Central decoder B on	6, 10 (7)							

*'(')' indicates the number of the digit in the listed binary words, which carries the "yes/no" information.

converters, two clocking oscillators, 17 voltage controlled oscillators, and associated mode control, rate switching, and signal conditioning amplifiers and networks. This equipment is contained in several major units, which may be identified in the equipment shown in Fig. 3. These units are:

(1) The Central Signal Processor (CSP), which contains the two A-to-D converters, the two sync clock oscillators, three SCO's, four summing amplifiers, and various switching and mode selection circuitry.

(2) The Engineering Signal Processor (ESP), which contains a 100-signal commutator, digital word assembly circuits, signal selectors for four modes of operation, and 6 SCO's for gyro, reject/enable, and accelerometer inputs.

(3) The Auxiliary Engineering Signal Processor (AESP), which contains a 120-signal commutator, digital word assembly circuits, signal switching for the coast and thrust modes, and VCO's for accelerometer and strain-gage inputs.

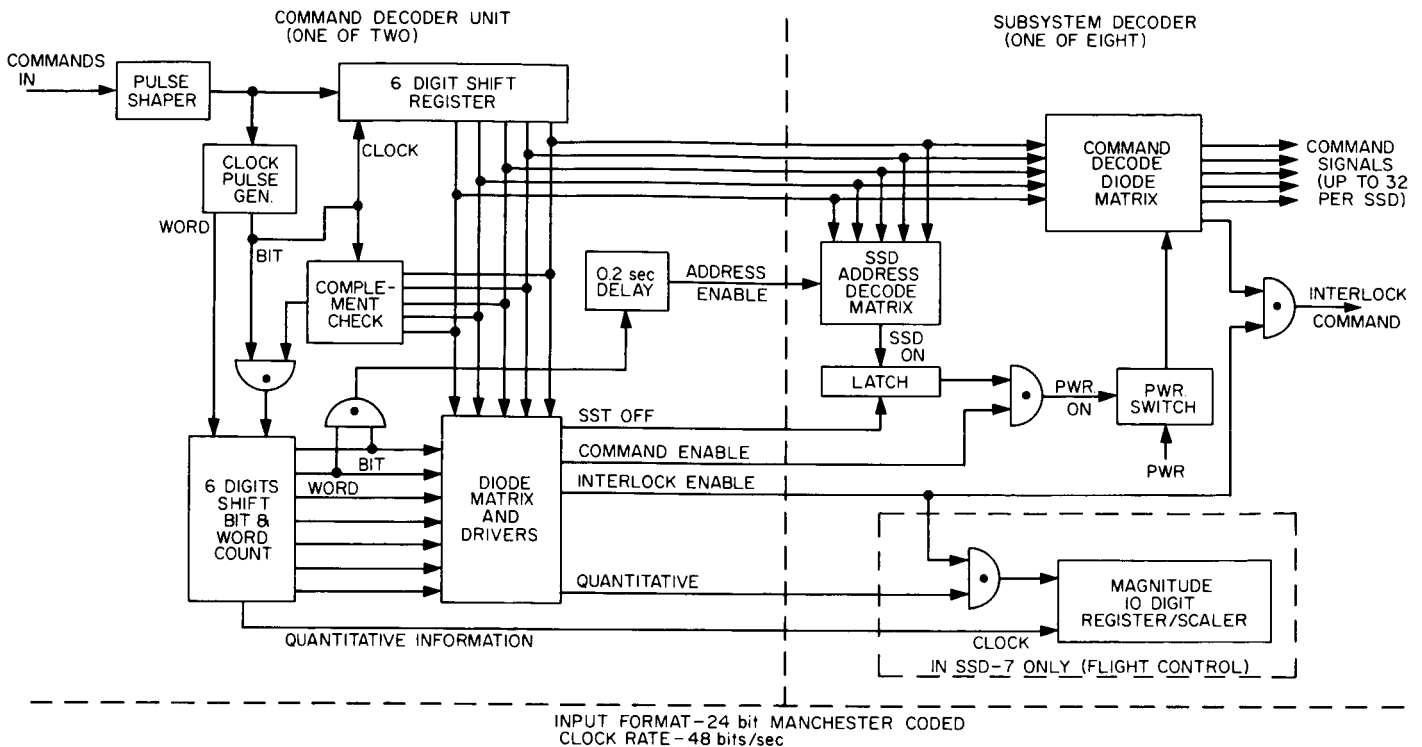

Fig. 8. Surveyor command decoding block diagram

Protections on the accuracy of the commands are attained by the transmission of a command "enable" or command "reject" signal via telemetry whenever a command passes or fails to pass the complementation test within the Central Command Decoder. In the case of a magnitude command, the entire command is retransmitted back from the spacecraft, since complementation is not possible.

VII. Signal Processing

The signal processing output on *Surveyor* is primarily PCM/FM, which may modulate the transmitters in either PM or FM. The PCM comprises commutated signals encoded into 11-bit binary coded words, 10 bits of data for each signal sample plus a parity bit. The system is also capable of providing direct frequency modulated analog signals for certain engineering measurements. Television is directly frequency modulated on the transmitters.

Table 6 shows a typical group of telemetry measurements, in this case only those associated with the RF link. The binary or so-called "digital" signals indicated in Table 6 are "on-off" information carried by individual

bits in certain 11-bit words. These "digital" words are "assembled" in several locations in the signal-processing equipment, and then inserted in the overall commutated stream of data at the proper time. The logic is so arranged that successive digital words may derive from different commutators. Thus, in a frame of words, Digital Words 1, 2, 3, 4, and 9 are taken from the Flight Control Sensor Group; Digital Words 5 through 8 are assembled in the Engineering Signal Processor; and Digital Words 10 through 13 are assembled in the Auxiliary Engineering Signal Processor.

Note that there are six possible modes for receiving various combinations of commutated data. There are 261 telemetry measurements included in these six modes, as was previously shown in Table 3, but only seven of these measurements are directly related to the signal processing. It is interesting to note, however, that the 56 commands for signal processing are more than twice the number provided for any other subsystem; this is indicative of the telemetry flexibility and relative complexity.

The signal processing equipment on *Surveyor* comprises three commutators, two redundant analog-to-digital

- (4) The Signal Processing Auxiliary (SPA), which contains the Low Modulation Index 3.9 kHz SCO.
- (5). The Low Data Rate Auxiliary (LDRA), which contains a countdown clock to enable low-speed operation of the signal processing equipment, and two SCO's to provide PCM/FM output.

There are also elements of the signal processing in other parts of the spacecraft, as follows:

- (1) Part of the Television Auxiliary (TVA), which contains 2 television subcarrier summing amplifiers, a 16-count commutator, and other signal processing related to television engineering information.
- (2) Part of the Flight Control Sensor Group, which contains the quantitative command register/scaler, signal processing related to flight control, and digital word assembly circuitry.

The entire system operates from power which is called the "29-v nonessential bus." This means that, should a malfunction develop in the spacecraft which reduces its

power delivering capability, the signal processing would be cut off to protect such functions as receivers, command decoding, and flight control, which operate from the "29-v essential bus." In *Surveyor I*, this power-selection process (boost regulator trip) was disabled for various reasons.

Figure 4 is useful to portray the general functional arrangement of the signal-processing equipment. The three lower left-hand blocks— analog to digital (A-to-D, or A/D) converters, commutators, and rate select—are shown in greater functional detail in Fig. 9.

The commutation in each commutator is accomplished by applying a "commutator advance signal" to the input of a 4 flip-flop 10-count circuit which addresses one side of a 10 × 10 matrix, and the output of this 10 count is applied to another counter of a similar circuit, which addresses the other coordinates of the matrix. The first counter may be said to be the vertical, and the second counter the horizontal count of the commutator matrix. Thus, the commutator will count down in the vertical

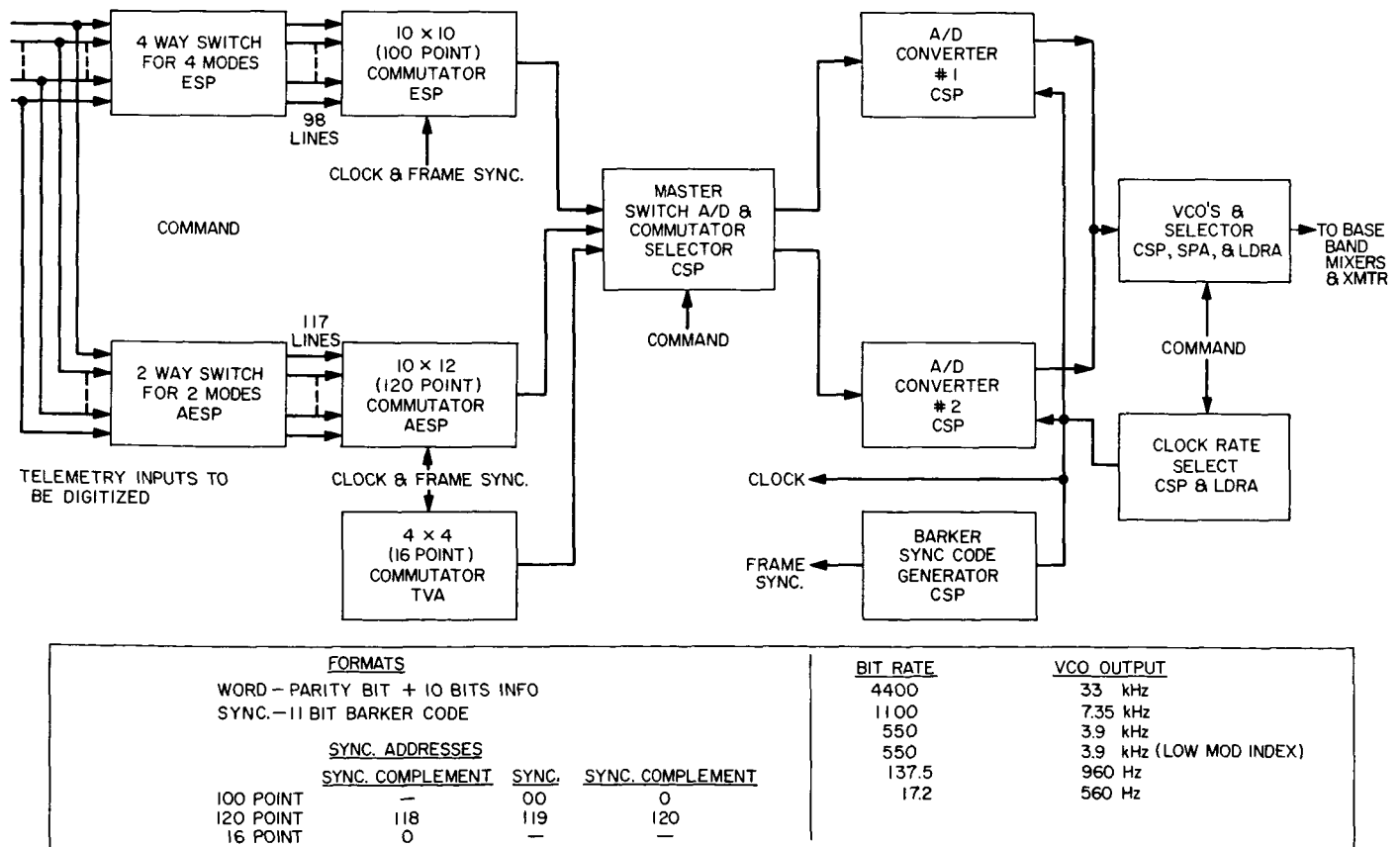

Fig. 9. Surveyor simplified commutation and A/D functions

"Y" circuit 10 counts before stepping to the next horizontal "X" position. There are 10 "Y" positions in both the ESP and the AESP, and 10 "X" positions in the ESP, but there are 12 "X" positions in the AESP. This provides a 100-word count capacity in the ESP, and a 120-word count for the AESP.

These count positions typically represent two possible information inputs for each count position in the AESP, and either 3 or 4 information inputs for each count position in the ESP. These inputs are divided into groups of similar nature, and these groups are separately selectable by the mode select commands from ground. Each mode selects many different groups, and a given group may be included in several mode selections.

The complete sequence of all count positions in a commutator and in the transmission of the associated data words is called a "frame" of data, for the sequence is transmitted over and over in the same sequence just like elements of a picture "frame."

Synchronization of the information "frames" is accomplished by sending a *sync* and *sync-complement* signal at specific word times at the beginning of the frame. These occur at words 00 and 0 in the ESP, and as words 118, 119, and 120 in the AESP. The synchronization signal is a Barker code (11100010010), which is a calculated series of 11 digits which would be the least likely to occur at random in a binary digital sequence. In the ground decommutator, the Barker code and the Barker code complement are used as the *commutator sync* indication and commutator synchronization signals.

Central timing and digital clock signals for the entire system are generated in the analog-to-digital (A-to-D) converters. The selection of one or the other of these A-to-D converters is under ground command, and provides a backup should one of the A-to-D's or its internal clock fail. The oscillators which control the clock frequency in the A-to-D converters operate at 35.2 kHz under crystal control. This frequency is divided down to 8800 Hz. The 8800 Hz is counted down by a series of flip-flops in the Bit Rate Selectors where 4400, 1100, or 550 bits/sec operation may be selected. To accommodate unexpected or degraded RF link performance, an additional Low Data Rate Auxiliary has been provided wherein additional countdowns to 137 or 17.2 bits/sec may be selected by ground command.

The internal operation of the A-to-D converter employs a 4 flip-flop eleven count circuit, which provides the

timing signals for the 10 binary voltage weighting switches. The incoming signal which has been commutated to the A-to-D converter is compared to a precision reference voltage made of the algebraic sum of all previously selected voltage weightings, plus one-half of the last trial value.

Starting with one-half of the full-scale reference voltage, the incoming voltage is compared. If the input voltage is greater than the reference value, the one-half full-scale weighting value is retained. If the input value is lower than the one-half value, then the reference is abandoned. Next, one-half of the previous trial value is added, making a three-quarter or one-quarter full-scale reference, depending upon whether the input was above or below the half value. Again, a comparison is made, and again the voltage weighting is added or abandoned, depending upon the input voltage.

This process is repeated 10 times, and a binary code of 10 bits is assembled by the binary weighting switches. At the end of assembly, the 10-bit code is provided with a one-bit parity, and transmitted serially by signals derived from the active commutator clocking.

The digital words modulate any of six subcarrier oscillators, as shown in Fig. 10. Notice that the selected subcarrier oscillator is a function of the selected bit rate, and in the case of the normal 550 bits/sec rate, a special low modulation index mode is selectable wherein the RF transmitter deviation is held to approximately 0.3 rad. (This leaves most of the power in the RF carrier which facilitates ground acquisition of the spacecraft signal for launch tracking and doppler determinations.)

Figure 10 is not entirely functionally accurate, for it implies that each particular subcarrier for the PCM is switched-in with its associated bit rate. This is intended to be the normal operating condition, but the individual subcarrier oscillators must be switched by ground command, as well as the bit rate.

This condition accounts for the unconnected clock contact for the TV data gate position, which normally would have a 500 bit/sec rate; but any other condition may be commanded.

The PCM subcarrier oscillators are summed in the output with subcarrier oscillators carrying gyro information, strain-gage accelerometers, or TV information, depending upon the mode of operation, before modulating the transmitter.

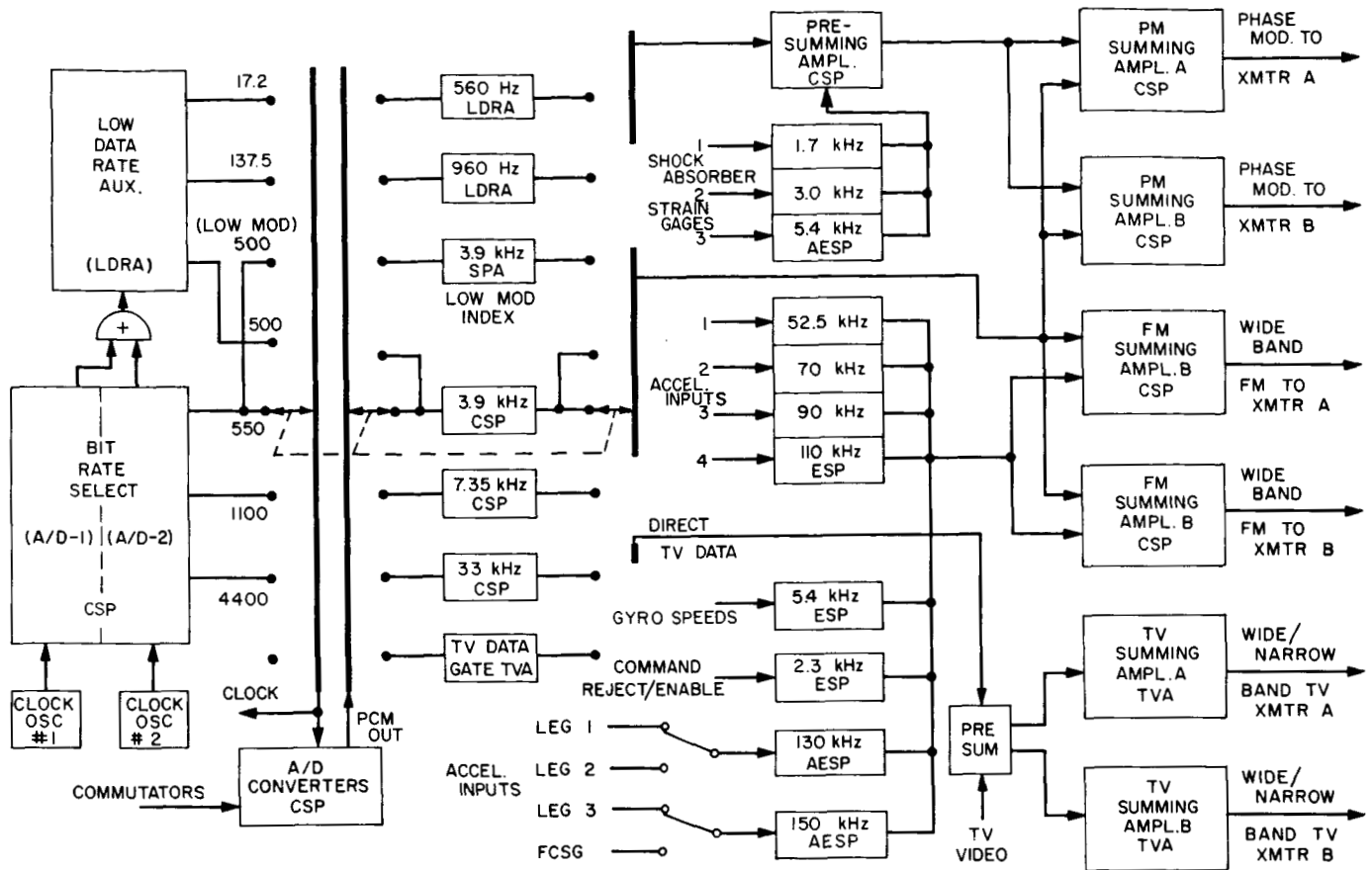

Fig. 10. Surveyor simplified VCO and mixing functions

Complete redundancy is again found in the final summing amplifiers which drive the two transmitter modulators.

It is not possible within the scope of this Report to cover all the various features, limitations, and logical interconnections built into the telecommunications system. It is intended, however, that the reader will have been able to understand the basic system structuring and the most significant operational capabilities.

VIII. Re-Design Requirements

As in the course of any system design, the Surveyor telecommunications suffered a few late surprises caused by the unsuspected system environment into which the subsystem parts were finally expected to operate.

A. High-Voltage Ionization

One of the latest discovered design problems proved to be a result of the thermal control environment. How-

ever, it was not a lack of adequate temperature control, but air trapped in the "super insulation" which affected the transmitter and RF diplexer design.

1. Transmitter design. As mentioned earlier, the boxes in which all telecommunications equipment is protected from the lunar temperature extremes do not out-gas below critical partial pressures for several days. This means that the transmitter must operate continuously under all power conditions in a partial pressure atmosphere.

Tests indicated that due to earlier packaging concepts, some of the transmitter "high power" power supplies were susceptible to partial pressure ionization breakdown. This was quickly cured by the Hughes Aircraft Company, by using a high-density "foam in place" technique which filled inaccessible voids in the supply.

2. RF diplexer design. The RF diplexer, which is an unsealed unit, was the next candidate, but sealing (and foaming) were out of the question. This time, borrowing from their aircraft experience, the Hughes Aircraft Company chose not to relocate the diplexer outside the box,

but to vent it separately to outer space by a flexible plastic pilot's tube connected to a hole in the diplexer wall at a region of low electric stress. Though this tube is little more than ¼ in. in diameter and about 2-ft long, it easily reduces the pressure in the diplexer to acceptable levels in just a few minutes.

B. Omnantenna Sticking

Each omnantenna is attached to the end of a wrapped fiberglass epoxy pole. Unfortunately, the dimensional stability of this construction proved to be less than was originally desired. To guarantee proper seating and actuation, a series of "deploy" tests was devised. These were a simulation of the explosive pin puller, and observation of the antenna actuation. It is now certain that these tests were not adequate, because on *Surveyor I* (for reasons

which are not well understood) the omnantenna A, which is manufactured with two bends and is the most difficult to control dimensionally, did not deploy until just before, or right at, touchdown. A subsequent investigation and design study have led to an additional assurance of deployment.

The original deployment force is provided by a "mouse trap" spring which acts at the antenna fulcrum. This is now augmented by a leaf-spring design which forces the antenna out of the restraining yoke in which it rests before deployment.

These re-design requirements are, of course, only three cases of design problems, but they are notable because they were only recently understood and corrected. Undoubtedly, there will still be others which arise, as we continue to "road-test" the *Surveyor* vehicle.