

FIRST SEMI ANNUAL PROGRESS REPORT  
ON  
IN SITU ORGANIC ANALYSIS  
OF THE LUNAR SURFACE

NASA Grant NGR-44-005-043

Principal Investigator:

John Oró  
Professor of Chemistry

FACILITY FORM 602

<u>N67 26063</u> (ACCESSION NUMBER)	_____
<u>24</u> (PAGES)	<u>1</u> (THRU)
<u>cl-83968</u> (NASA CR OR TMX OR AD NUMBER)	<u>06</u> (CODE)
	<u>06</u> (CATEGORY)

University of Houston

Houston, Texas 77004

## ABSTRACT

After evaluating several instruments, a quadrupole and a monopole mass analyzer have been selected as basic components of an integrated gas chromatographic-mass spectrometric system for the analysis of organic compounds.

This system has been assembled and tested in the laboratory. The results obtained with the new apparatus are comparable to those obtained with much heavier instruments.

Further experimental work will be necessary in order to determine the potential application of a similar (compact and automated) instrument for the analysis of organic compounds on the Moon and planetary surfaces.

## TABLE OF CONTENTS

- I. INTRODUCTION
- II. SELECTION OF INSTRUMENTATION
- III. EXPERIMENTAL (DESCRIPTION OF INSTRUMENTATION)
  - A. Mass-Spectrometer
  - B. Gas Chromatograph and Sample Inlet
  - C. Vacuum System
  - D. Data Readout Systems
- IV. SUMMARY OF RESULTS AND DISCUSSION
- V. LIST OF FIGURES
  - 1. Laboratory Mass Spectrometer-Gas Chromatograph LKB 9000
  - 2. Block Diagram of Pre-Prototype Lunar Analysis System
  - 3. Test Gas Chromatograph
  - 4. Test Vacuum System Diagram
  - 5. Temporary Test Vacuum System
  - 6. Test Readout and Control System
- VI. GC-QUADRUPOLE MASS SPECTROMETRIC ANALYSIS OF ORGANIC COMPOUNDS (COPY OF ARTICLE J. GAS CHROMATOG. IN PRESS)

## I. INTRODUCTION

The general instrumental and analytical objectives as described in the proposal for the In Situ Organic Analysis of the Lunar Surface provided the basic work platform for this period of accomplishments. This report is a summary of the work carried out in the first six months of the project. Although it was originally planned to conduct a workshop of visiting experts at this laboratory, in the interest of time and economy, the workshop was deleted. In lieu of the workshop the staff visited and viewed first-hand other laboratories engaged in similar research projects. These visits accelerated the program by permitting us to avoid many of the pitfalls experienced by other researchers. Thus, it became possible to begin the project just beyond a point that other laboratories are now striving to achieve. The following is a partial list of the visits.

1. General Electric Company, Schenectady, N. Y.
2. Electron Associates, Inc., Palo Alto, Calif.
3. Varian Associates, Palo Alto, Calif.
4. Midwest Research Institute, Kansas City, Mo.
5. The Avco Corporation, Tulsa, Okla.
6. The Jet Propulsion Laboratories, Pasadena, Calif.
7. The Bell and Howell Research Center, Palo Alto, Calif.

Essentially the analytical data collected on the LKB Model 9000 Combination Mass Spectrometer-Gas Chromatograph shown in photograph, Figure 1., guided the choice of instrumentation for this project. It was surmised that equivalent data collecting ability on the surface of the moon would, in fact, yield the scientific information ultimately desired in accordance with the aims of the NASA space exploration program.

With the above in mind an equipment evaluation phase was undertaken and the block diagram shown in Figure 2 was constructed. Section II is a report of this phase with particular emphasis on the choice of the mass spectrometer. Simultaneously, a literature survey was made to determine optimum analytical procedures, the most applicable samples to analyze, and to evaluate the present state of research in this area.

Section III is a concise description of the experimental apparatus. (Section V shows actual photographs of the equipment). A summary of the results and a brief discussion of these results is presented in Section IV. This section describes some of the gas chromatographic and mass spectral data collected and how it compares to that obtained with the LKB 9000 instrument. A publication of this work is reproduced in Section VI.

## II. SELECTION OF INSTRUMENTATION

The selection of the pre-prototype mass-spectrometer for the In Situ Organic Analysis of the Lunar Surface project required a major instrument investigation and eventual decision to be made. The initial approach was to examine all of the instruments which are theoretically capable of providing the necessary mass analysis. This included practically all the known mass-spectrometers. The following types of mass analyzers were considered potentially capable of the In Situ analysis:

1. First order momentum focusing, magnetic deflection (Nier type)
2. Double focusing, energy and momentum focusing combination electrostatic magnetic deflection (Nier-Johnson and Mattauch-Herzog)
3. Paul quadrupole mass filter
4. von Zahn monopole mass filter
5. Bendix time-of-flight
6. Hipple-Sommers omegatron
7. Bennett radio frequency
8. Machlett radio frequency
9. Johnston Laboratories coincidence
10. Cyclodial focusing magnetic-electric
11. Dempster first order magnetic deflection

Each of these instruments was carefully examined to determine their present and past performances. methods employed include direct observation, reviewing the literature, and visiting laboratories where particular instruments were

being designed and placed in operation. Also considered were possible modifications of any of these instruments which might render them more useful for analysis on this project.

Critical examination of the above instruments was made considering the basic instrument performance requirements, in particular the following crucial requirements:

1. Mass range of  $m/e$  to 150 amu
2. Resolution to  $m/\Delta m$  of 150
3. Generally flyable characteristics
4. Demonstrated capability within the present state of technology

In light of these operational requirements, a more precise definition of potentially usable instruments was derived. The following instruments were thought to have the basic potential capability:

1. A quadrupole mass filter with approximately 5" rods
2. A monopole mass filter with approximately 5" "Vee" and rod assembly
3. A 4" radius of momentum focusing magnetic deflection mass analyzer, of either the Nier or the Dempster type
4. A 2" or 3" radius combination electrostatic-magnetic double focusing mass analyzer of the Nier-Johnson or the Mattauch-Herzog configuration

The next step in this study covered the more practical problems in this choice of an instrument. These problems included availability, cost, and operational convenience. The double-focusing devices were eliminated at this point because they must be designed, engineered and constructed on a custom basis. No instrument of this general type is commercially available. Although these have in fact been constructed, flown, and possess a performance potential above the others, the choice of this device would severely impair the time schedule of the project. The single-focusing magnetic sector instruments were eliminated for essentially the same reasons. This left the quadrupole and the monopole mass filters as the prime candidates for this duty.

An extensive study was made of the quadrupole and monopole mass filters, and current relevant technical information was collected from many laboratories. In an effort to obtain reliable first-hand information investigators in several laboratories employing these mass spectrometers, were visited and consulted on the operation of their instruments. For the purpose of this project, the following is a summary list of general characteristics and availability pertaining to both the quadrupole and the monopole mass filters, or to either of them.

- A. QM - Quadrupole and Monopole
- B. M - Monopole only
- C. Q - Quadrupole only



A. Quadrupole and Monopole

1. No magnet is required
2. Low ion energies
3. The ions may be relatively non-homogenous in energy
4. Compatible with secondary electron multipliers of any type
5. Good vacuum characteristics and easily outgassed
6. Large and somewhat unpredictable mass discrimination
7. Relatively simple mechanics
8. Relatively complex electronics
9. Normally uses a special open structured ion source, but compatible with a conventional one
10. Mass range to 600 amu under very special conditions, but reliably to 150 amu
11. Resolution to one part in 500 under very special conditions; reliably to one part in 150
12. Sensitivity to  $10^{-15}$  torr nitrogen partial pressure
13. Dynamic range to  $10^6$
14. Very little analytical data available
15. Exceedingly complicated theory of operation
16. Exceedingly temperamental at optimum performance but reliable at minimum requirements

B. Quadrupole only

1. Flown in space many times by many investigators
2. Subject of much present investigation in many laboratories, although relatively new

3. Quadrupoles have been built by Atlas-Werke, Varian Associates, Electron Associates, Inc., Bell & Howell Research Center, Consolidated Electrodynamics Corp., Air Force Cambridge Research Laboratories, The University of Michigan, University of Minnesota, Massachusetts Institute of Technology, Jet Propulsion Laboratories, and several National Aeronautical and Space Administration Centers.
4. An applicable quadrupole-mass spectrometer is readily available from Electron Associates, Inc., (E.A.I.)

C. Monopole only

1. An applicable monopole is readily available from the General Electric Company (not built by anyone else at this time)
2. Has a tendency to build up space charge on the "Vee" electrode
3. Operates with an asymmetric ion beam with non-axial entry and exit of this beam

This data implied that the quadrupole and monopole both had advantages and disadvantages, but the instruments, although not identical, were somewhat equivalent. Visits to several installations confirmed these facts. Therefore, the decision was made to procure both the EAI quadrupole and the General Electric monopole. The overall experimental system was designed to capitalize on the unique features of each device.

This approach was intended to expedite the project and not to provide a comparison of instruments--our purposes lie beyond instrumental evaluation. Thus, most of the effort was directed towards the maximum utilization of existing technology, developing only where a need exists or an improvement is obvious. Although we shall remain cognizant of other mass spectrometric instrumentation, present plans are to develop and employ a quadrupole and monopole mass filter for this project.

The studies which resulted in the selection of the ancillary equipment used in this study followed similar lines of reasoning to those used in the selection of the mass spectrometer. Inlet systems, readout systems, and vacuum systems were selected mainly on the basis of functional considerations. Certain ideal factors were sacrificed because of the limited time schedule. In general, however, the basic instrumental requirements were maintained and the overall objectives of the first phase of the project were fulfilled.

### III. EXPERIMENTAL (DESCRIPTION OF INSTRUMENTATION)

The instrumentation for this project was based on the ultimate objectives of the project along with the desire to produce more useful solutions to the problems investigated. This governed the detailed design of the vacuum systems, the mass spectrometers, and the plan of data collection. By the approach used in the selection of instrumentation start-up time has been reduced to a minimum.

#### A. Mass Spectrometers

The mass analyzer section of the system is made up of two commercially available Paul type mass filters. An EAI Quadrupole Model 250 and a General Electric Monopole II are operated in parallel to show simultaneous mass spectra of the same sample.

The EAI Quadrupole 250 Residual Gas Analyzer differs from the standard model only slightly. The Multiplier power supply is a John Fluke Model 408B regulated high voltage power supply to provide extra stability and range. The electrometer Amplifier is a Keithly Model 417 BR for extra dynamic range and peak height accuracy. Minor modifications are made to the sweep circuits to produce more analytical type mass spectra. The ion source and its associated

controls are quite standard and appear very satisfactory.

The General Electric Monopole II Partial Pressure Analyzer has been modified to a somewhat greater degree than the quadrupole because a less versatile design was provided by the manufacturer. A Power Designs Model HV-1556 regulated high voltage supply is used to drive the electron multiplier to produce the necessary sensitivity and stability. A Keithly Model 417 BR electrometer amplifier is used to extend the sensitivity, dynamic range, and stability.

The sweep functions are produced by a Tektronix Type T Time-base Generator and Tektronix Type 127 Preamplifier power supply. Although the instrument has total ion current monitor capability, it is being used in the conventional mode at this time.

#### B. Gas Chromatograph and Associated Sample Inlet Systems

The gas chromatograph and the associated sample inlet systems are outlined in the block diagram of Figure 2 and the pertinent parts of the apparatus is shown in the photograph, Figure 3. Up to the present time, a 500 ft. 0.03 in. diameter stainless steel, 10% SF-96 (100) coated, capillary column has been used to perform the gas chromatographic separations because of the limitations of the temporary vacuum system. Hydrogen

has been employed as the carrier gas.

The inlet assembly is composed of the following equipment:

1. A Barber-Coleman Series 5000 Gas Chromatograph with capillary column, a temperature programmed oven, a hydrogen flame detector and the gas control accessories.
2. A mass spectrometer heated direct inlet system.
3. A pyrolyzing oven.
4. Several bakeable variable leak inlet valves for flow control into the vacuum.

#### C. Vacuum System

A basic vacuum system was designed as shown in Figure 4 to fulfill all the needs of the experiment. Because of delivery problems a Ultek standard bench-top bell jar system was substituted for this phase of the project. This is shown in the photograph, Figure 5.

The following is a detailed description of the vacuum system which will be made operable as equipment is delivered. Its design objectives include: maximum versatility, the ability to pump the entire elutant, ultimate pressure of  $10^{-11}$  torr and near lunar environment for the entire system as required. The unique features of this system revolve about the combination

of pumping mechanisms.

1. Chamber comprising:

Twelve inch diameter bell jar fully bakeable with viewports, leak valves and ports for mass spectrometers, gages, controls, etc.

2. Pumping System consisting of:

- a. 200 liters/second Cold Cathode sputter ion pump (Vetek)
- b. 4000 liters/second Hot filament titanium sublimation pump (Ultek)
- c. 4000 liters/second Electron Beam Titanium sublimation pump (Andar)
- d. 2500 liters/second Polyphenylether diffusion pump (NRC)
- e. 20 cfm mechanical pump (Edwards)
- f. Cryogenic traps, molecular sieve traps, vacuum valves, connections, etc.

3. Gaging and Measuring consisting of:

- a. Bayard-Alpert ionization gage controller with nude tubes for basic measurements to  $10^{-11}$  torr.
- b. Special Cold Cathode discharge gage, tube to control inlet pressure measurements to  $10^{-6}$  torr. (Phillips)
- c. Thermocouple gaging for fore lines and

rough pumping pressure measurements to  
 $10^{-3}$  torr.

#### D. Data Read Out Systems

The data read out systems provide test and appraisal information along with basic sample data. The photograph, Figure 6, and the block diagram, Figure 2, show the integrated system, as planned and as used.

The following list details the individual components:

1. Infotronics Model CRS-11AB/H/61 data integrator and digitizer for the gas chromatograph.
2. Leeds and Northrup strip chart potentiometric recorder for general chromatographic display and special mass spectral display.
3. Tektronix Model RM 564 Storage Oscilloscope with Type 3 preamplifier and Type 3B4 time base for general mass spectral display.
4. Honeywell 1509 Visicorder direct writing recording oscillograph with six Accudata 104 preamplifiers for analytical mass spectra display.

#### 5. Major Ancillary Equipment

Major ancillary equipment necessary for routine operation and optimum reliability includes a Consolidated Electrodynamics Model 24-120B



helium mass spectrometer leak detector, a Tektronix Model 545 oscilloscope, a Unitek 1-065-02 spot welder, special electrometers, power supplies, vacuum gages, etc.

#### IV. SUMMARY OF RESULTS AND DISCUSSION

Preprototype equipment has been assembled and tested based on information obtained from this laboratory. The test and evaluation phase has in general affirmed the choice of systems. In this phase, selected samples were used to determine the operation of the integrated system by evaluating the gas chromatograph efficiency and the basic performance of the mass spectrometers.

The following samples were analyzed and compared on LKB 9000 gas chromatograph mass spectrometer system and the preprototype lunar gas chromatograph mass spectrometer system:

- A. Normal Paraffins C<sub>6</sub> through C<sub>10</sub>
- B. Aromatic Hydrocarbon Mixture
  - 1. Benzene
  - 2. Toulene
  - 3. Ethylbenzene
  - 4. o-Xylene
  - 5. Mesitylene
- C. Bio-organic Pyrolysis Type Fragments
  - 1. Acetonitrile
  - 2. Furan
  - 3. Pyrole
- D. Significant Bio-organic Compounds
  - 1. Pristane

2. Phytane
3. Farnesane

E. Standard Calibration Compounds

1. Perflurokerosene
2. Perflurotributylamine
3. 2,6-Dimethylheptane
4. 2,6-Dimethyloctadiene

The presentation and discussion of these data in detail is beyond the scope and purpose of this report. However, a paper describing some of the results obtained has been written, a copy of which is attached (section V). This work will be presented at the Fourth International Symposium--Advances in Gas Chromatography in New York City on April 3-6, 1967, and will published at that time.

The results thus far achieved provide a reasonable degree of confidence on the possible utilization of the selected instrumentation. In the evaluation of the mass spectrometers it was found that mass spectra on the preprototype instrument is sufficiently similar to that obtained on the LKB 9000 system to permit sample identification. The mass spectrometers displayed adequate sensitivity when operating at a resolution comparable to the sector instrument. While both preprototype mass spectrometers are operating at a resolving power of  $m/\Delta m$  of 250 (based on the 10% valley definition) the different

*Not  
Attached*

operating parameters produce information in one that is not in the other. Problems related to mass discrimination and non-linear resolution will require further investigation.

A new pyrolyzing system is now being constructed and more pyrolysis products of bioorganic-type samples are being investigated. These results will be checked utilizing several methods of analysis and internal standards. The completion of assembly of the more suitable vacuum system will be realized as soon as all the components are available. As this point is reached, additional effort will be applied to the task of making any necessary improvements to the experimental apparatus. New types of samples are being collected and will be analyzed concurrently. Interpretations based on data collected from these analyses will provide the precise information necessary to plan the next major phase in the In Situ Organic Analyses of the Lunar Surface.

#### V. LIST OF FIGURES

Figure 1. Laboratory Mass Spectrometer-Gas Chromatograph  
LKB 9000

Figure 2. Block Diagram of Preprototype Lunar Analysis System

Figure 3. Test Gas Chromatograph System

Figure 4. Test Vacuum System Diagram

Figure 5. Temporary Test Vacuum System

Figure 6. Test Readout and Control System



FIGURE 1. LABORATORY MASS SPECTROMETER GAS  
CHROMATOGRAPH LKB 9000

# BASIC INSTRUMENTATION

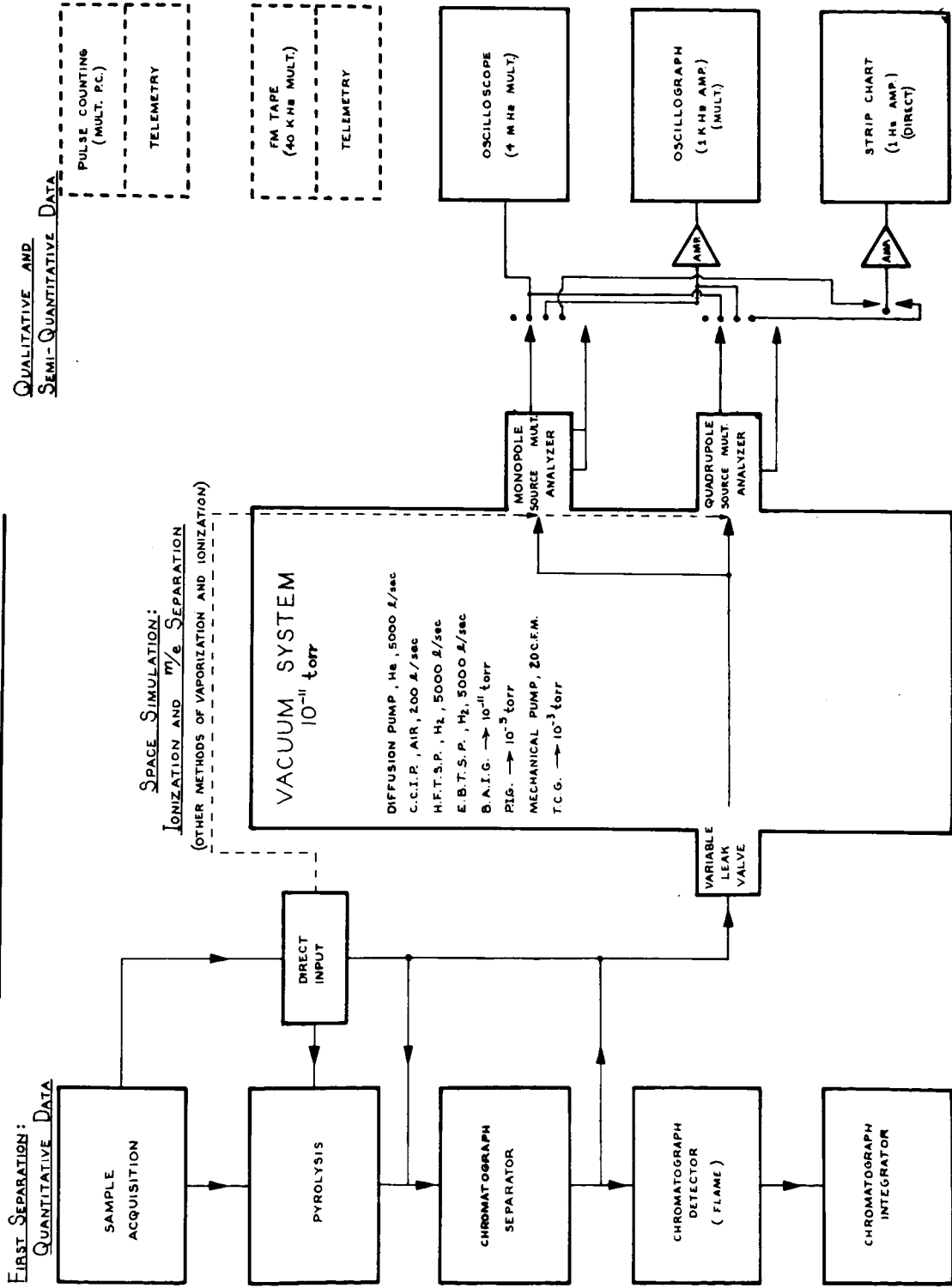

**FIGURE 2. BLOCK DIAGRAM OF PRE-PROTOTYPE LUNAR ANALYSIS SYSTEM**

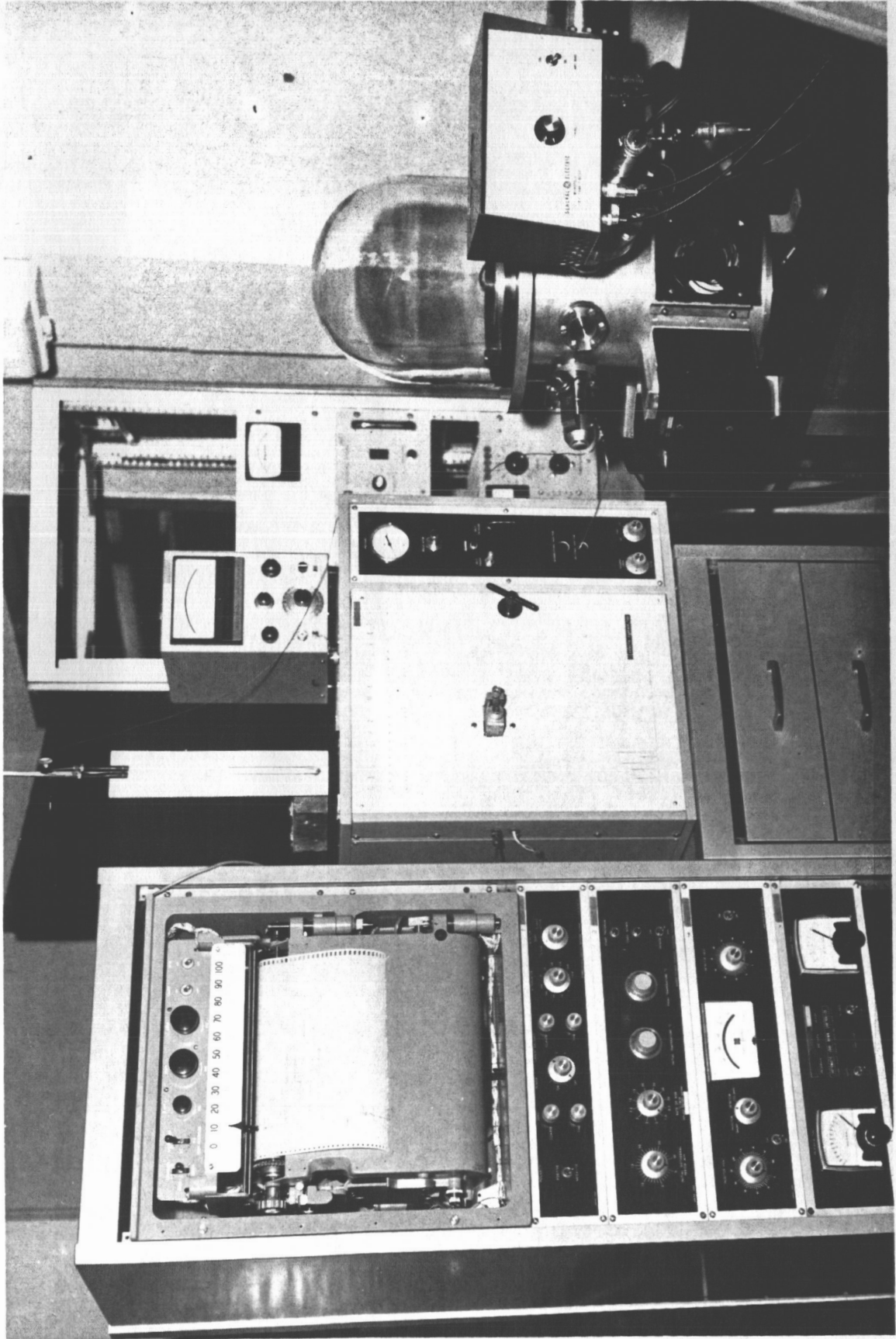
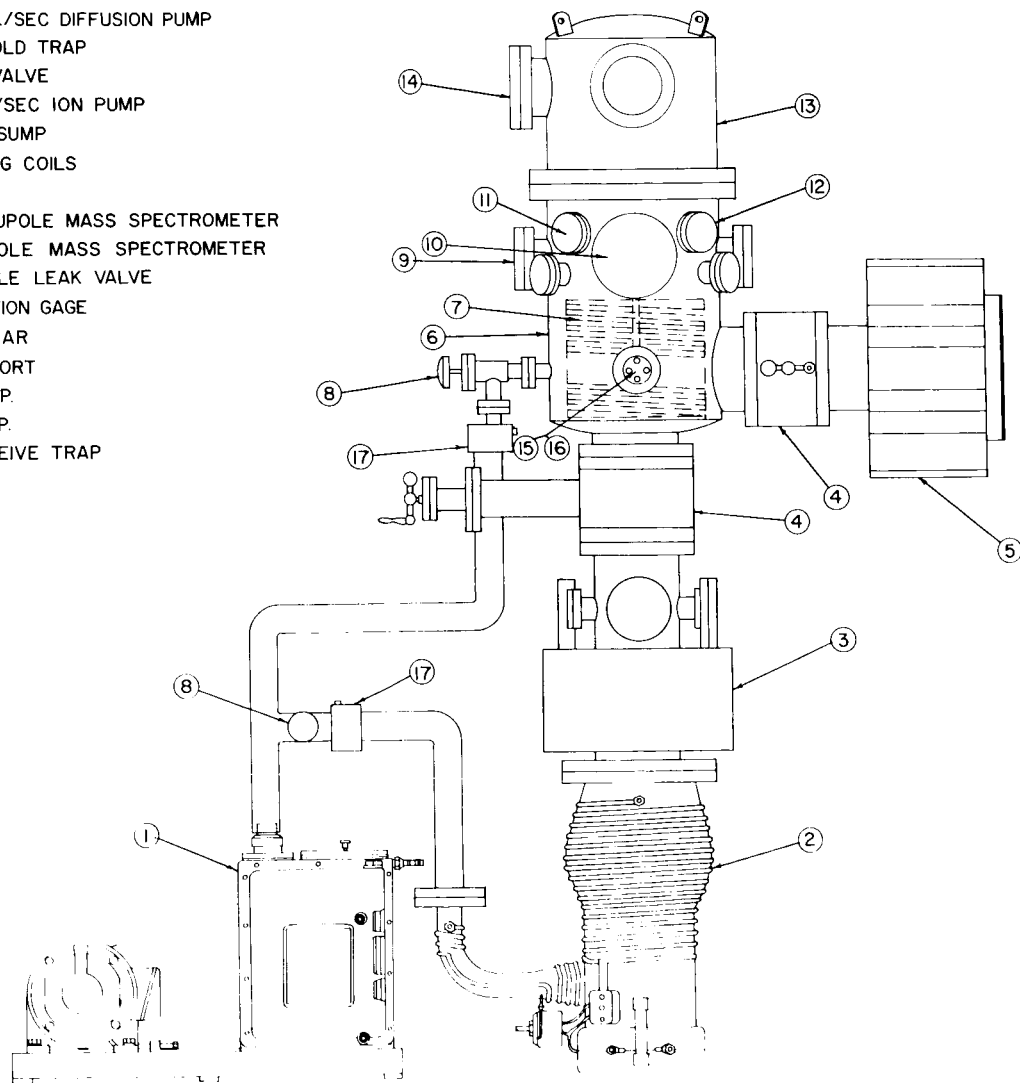

FIGURE 3. TEST GAS CHROMATOGRAPH

- ① 20 cfm MECHANICAL PUMP
- ② 2500 L/SEC DIFFUSION PUMP
- ③ LN<sub>2</sub> COLD TRAP
- ④ GATE VALVE
- ⑤ 200 L/SEC ION PUMP
- ⑥ PUMP SUMP
- ⑦ COOLING COILS
- ⑧ VALVE
- ⑨ QUADRUPOLE MASS SPECTROMETER
- ⑩ MONOPOLE MASS SPECTROMETER
- ⑪ VARIABLE LEAK VALVE
- ⑫ IONIZATION GAGE
- ⑬ BELL JAR
- ⑭ VIEW PORT
- ⑮ H.F.T.S.P.
- ⑯ E.B.T.S.P.
- ⑰ MOLESEIVE TRAP



**FIGURE 4. TEST VACUUM SYSTEM DIAGRAM**



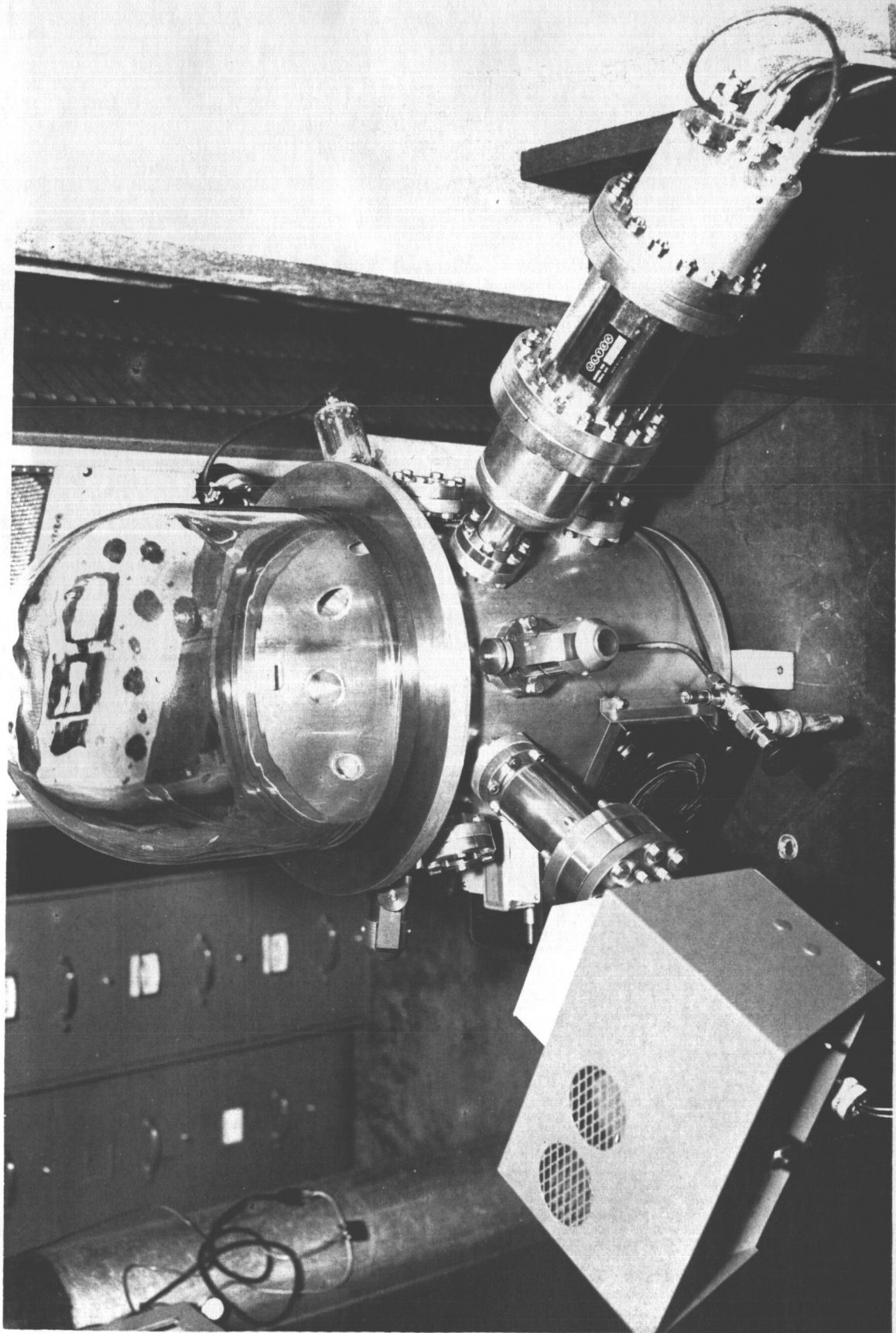

**FIGURE 5. TEMPORARY TEST VACUUM SYSTEM**

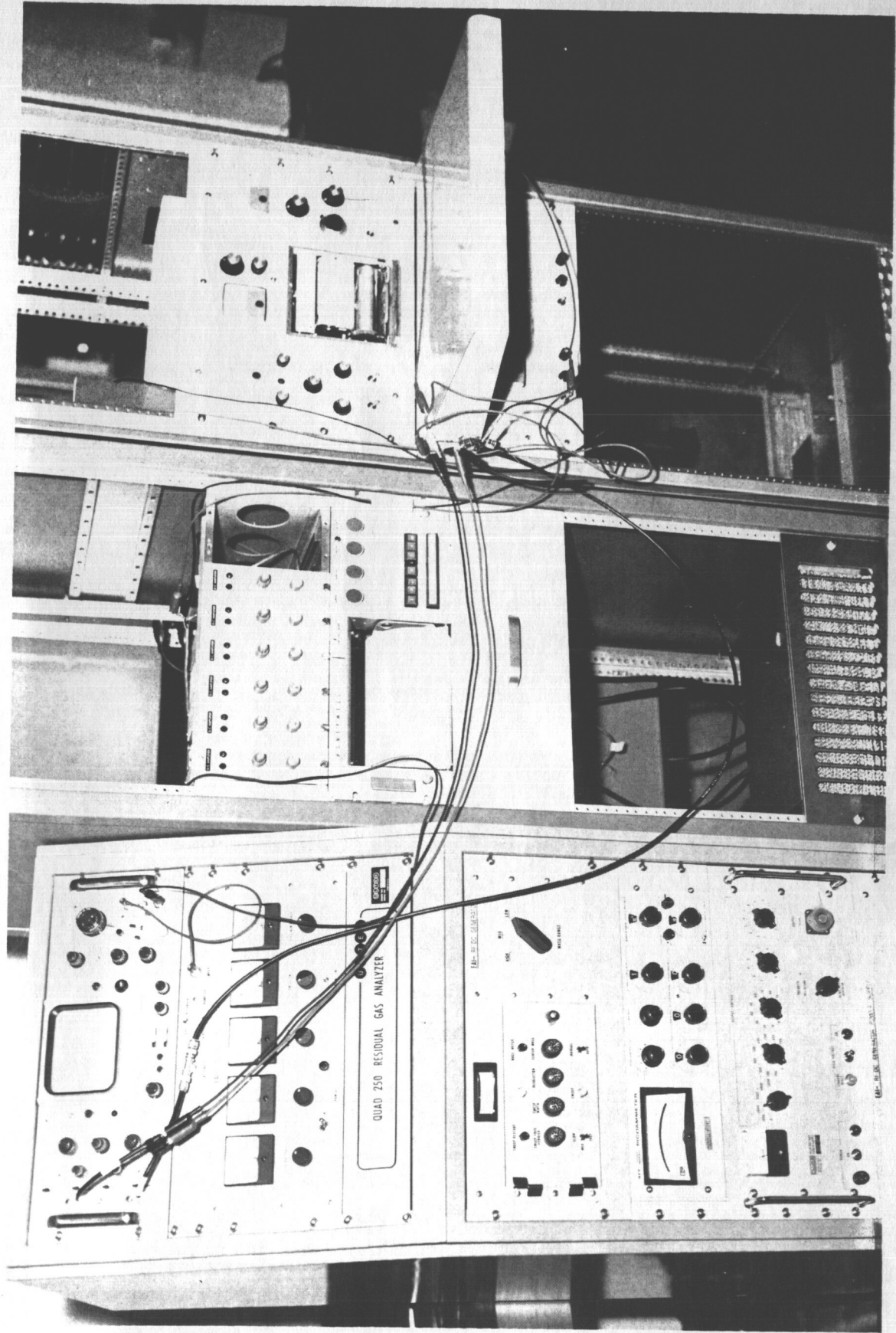

FIGURE 6. TEST READOUT AND CONTROL SYSTEM