

U. of Iowa 67-8

3 The Latitude - Local Time Dependence of
Low Energy Cosmic Ray Cut-Offs in a
Realistic Geomagnetic Field * 6

by

2 6 Harold E. Taylor **9 3
Department of Physics and Astronomy
1 University of Iowa
Iowa City, Iowa 2

9 May 1967 10CV

* Research supported by the National Aeronautics and Space
Administration under research grant NSG-233-62.

** 26 29CV
Now NAS-NASA Post Doctoral Research Associate at Goddard Space
Flight Center, Greenbelt, Maryland.

ABSTRACT

A numerical program for integrating the equation of motion of charged particles in the Taylor-Hones model of the geomagnetic field is developed and used to calculate a large number of trajectories of 1.2 MeV protons arriving from infinity (solar cosmic rays). Only those particles which approach the earth to an altitude of ≤ 2000 km are considered. The results show that for such particles:

(a) Field lines attached to the earth at a latitude less than $\sim 65^\circ$ are inaccessible to particles of any pitch angle (0° to 90°) at 2000 km and for all local times;

(b) On the day side of earth, field lines between $\sim 65^\circ$ and $\sim 75^\circ$ are accessible only to particles having large pitch angles at the altitudes of ~ 2000 km (i.e., moving approximately orthogonal to the magnetic field vector); and

(c) The "polar plateau", an irregularly shaped region which is probably accessible to particles of all pitch angles 0° to 90° , extends from the pole to $\sim 65^\circ$ on the midnight meridian, to $\sim 75^\circ$ on the noon and dawn meridians, and to $\sim 70^\circ$ on the dusk meridian.

A comparison with the meager, observed data of Stone and of Harding gives some support to the validity of the calculation.

INTRODUCTION

It has been clear for some time that the entry of low energy cosmic rays into the earth's atmosphere is not adequately explained by Störmer theory. A recent study of this matter using riometer data has been published by Leinbach, Venkatesan, and Parthasarathy [1965]. Direct measurements of solar protons in the 1 to 10 MeV range with satellite detectors also show in a conclusive way that such particles can penetrate to much lower latitudes than predicted by Störmer theory for an idealized dipolar magnetic field [Maehlum and O'Brien, 1962] [Pieper et al., 1962] [Stone, 1964] [Harding, 1966]. The inclusion of higher order terms in the harmonic expansion of the earth's surface field does not account for these findings [Sauer, 1963]. Moreover, the observations show that cut-offs are dependent on local time, a feature which is absent from any axially symmetric field model.

In the present work, an attempt is made to understand these marked discrepancies through the use of a realistic model of the distant geomagnetic field. The model includes the sunward boundary of the magnetosphere and an extended geomagnetic tail--distortions of the earth's field caused by its interaction with the solar wind.

It is found that the geomagnetic tail and the current sheet associated with it have a large influence on the paths of solar cosmic rays [cf. Reid and Sauer, 1967].

Qualitatively the effect of these magnetospheric features on cosmic rays can be explained as follows. The magnetic field strengths are relatively weak in the magnetospheric tail, $\sim 20 \gamma$, so that 1-10 MeV protons can enter this region. The sharp curvature of the magnetic field lines at the current sheet effectively scatters these particles throughout the tail and thus provides access to those latitudes to which lines in the tail connect. On the sunward side of the magnetosphere the cut-off latitudes for direct access are roughly the Störmer ones; but at lower latitudes quasi-trapped particles which have drifted around from the tail are expected.

This paper reports the results of numerical integration of the equation of motion of a 1.2 MeV proton in the model magnetosphere of Taylor and Hones [1965]. Comparison is made with data taken during a time of little magnetic activity in mid-September 1961 as published by Stone [1964] and with the more extensive data of Harding [1966].

DETAILS

Particle trajectories are determined by numerically integrating the differential equation for the particle trajectory:

$$\frac{d^2\vec{x}}{ds^2} = \left(\frac{eB}{mcv} \right) \left(\frac{d\vec{x}}{ds} \right) \times \left(\frac{\vec{B}}{B} \right)$$

where \vec{x} is the position vector of the particle, s is the distance along its trajectory, e is its charge, m is its mass, v is its velocity, \vec{B} is the magnetic field vector, and c is the velocity of light.

The numerical integration routine used is a fifth order Runge-Kutta one, specifically Gill's method [Gill, 1951]. A listing of the program is available on request. The accuracy of the program is checked in several different ways. First a uniform magnetic field is used and the results compared to analytical ones. If the error is random for each step then the expected error after N steps of length Δ is $\Delta^5 N^{1/2}$. This means that after 400 steps or roughly $100 R_E$ (earth radii) along the path of a 1.2 MeV proton in a 20γ field, the expected error is $\sim 0.02 R_E$. In the uniform field the numerical position is found to be well within this distance of the analytical position.

The second method of checking uses the model field and makes use of the reversibility of the differential equation. If the sign of the charge and the direction of motion are both reversed the particle traverses the same trajectory in the opposite direction. Thus to check the program, the particle is traced outward for a certain distance then reversed and traced back in. After moving the same distance back the particle should be at its starting point. The stability of the routine depends critically on the step size chosen and the path length traversed before the computational reversal, i.e., on the number of steps taken. A suitable step size and the maximum distance are chosen empirically by requiring that the particle return to within $0.02 R_E$ of its initial position and be moving within 10° of its initial direction.

CALCULATIONS

With the above checks to insure that the numerical program is accurately solving the differential equation, the program is put to use tracing particle trajectories by starting a (negatively charged) proton above the ionosphere and following it outward. A maximum of $50 R_E$ path length or of 20,000 numerical steps, whichever occurs first, is placed on each orbit. The integration is terminated before reaching these limits if the particle returns to an altitude of 100 km, on the presumption that it will be absorbed by the atmosphere. The trajectories are also examined by hand to see which ones effectively escape from the magnetosphere.

The model magnetosphere used is shown in Figure 1. It is the field of a dipole representing the earth's magnetic moment plus an image dipole which produces the effects of the solar wind. In addition, on the anti-solar side of the earth the field of an infinite current sheet of finite thickness is added. A more detailed discussion of the model can be found in an earlier publication [Taylor and Hones, 1965]. The additional distortion of the magnetic field by a ring current is not included in this study, on the grounds of calculational simplicity, though it is well known

that observational values of geomagnetic cut-offs are responsive to geomagnetic storm activities [Akasofu, Lin, and Van Allen, 1963].

In the first phase of the study a particle is started at an altitude of about 2000 km in a direction anti-parallel to the magnetic field vector (northern hemisphere). Trajectories are computed at intervals of 1° in latitude from 60° to 80° for every 30° in longitude. Thus a total of 252 trajectories is calculated. The lower latitude trajectories at all longitudes are clearly forbidden ones since they intersect the atmosphere at a point approximately conjugate to the starting point. The region from which these field lines emanate is therefore inaccessible to particles from infinity.

Trajectories originating at higher latitudes exhibit a different character. Even though $v_{\perp} = 0$ initially, the trajectories have turning points (minimum altitudes) above the appreciable atmosphere in the opposite hemisphere on their first pass. The region of origin of such trajectories is called the scattering region and is shown in Figure 2 as the open region which includes the pole. The form of this region has a strong diurnal dependence. On the basis of qualitative considerations [cf. Introduction] it is believed likely that such trajectories will

usually lead to infinity, if allowed to continue for a sufficient length of time.

The region forbidden for particles arriving along the magnetic field vector is not necessarily forbidden for particles of all pitch angles. To investigate the point, trajectories are computed for particles which are started at an altitude of 1000 km with a pitch angle of 90° .

In this second phase of the study, 40 trajectories are calculated at intervals of 30° in longitude and 2° in latitude in the region where temporary trapping is suggested by the earlier calculations. The region is found to have a penumbra-like character. Some of the trajectories continue to exhibit latitudinal oscillation between turning points above the atmosphere for a path length as great as $100 R_E$ and for longitudinal drifts of $\sim 30^\circ$. Others strike the earth before reaching the $100 R_E$ limit. This penumbra-like behavior is also characteristic of a few additional trajectories computed for other initial pitch angles near 90° .

Otherwise stated, particles on many such trajectories are found to undergo a number of latitudinal oscillations, while drifting approximately along a longitudinal invariant surface. Thus, these particles are temporarily trapped. Because the scattering region extends to lower latitudes on the night side of the earth

than it does on the day side (Figure 2), many of the invariant surfaces on which particles are trapped on the day side will be in the scattering region on the night side. Hence particles coming in from infinity may become trapped on these surfaces on the night side and drift around to the day side as trapped particles. The region where such temporarily trapped particles are found is shown in Figure 2 as the heavily cross-hatched region. Only the lightly slashed region below 60° is inaccessible to 1.2 MeV protons of all pitch angles.

From the foregoing the following summary is suggested for 1.2 MeV protons approaching the earth from infinity: (a) At low latitudes (the lightly slashed region of Figure 2) no particles are expected; (b) at intermediate latitudes on the day side of the earth (cross-hatched region) only particles with large pitch angles are expected; and (c) at high latitudes (open region) particles of all pitch angles should be found.

EXPERIMENTAL COMPARISON

There have been very few experiments measuring the local time and pitch angle dependence of the cut-off of low energy cosmic rays. Stone [1964] investigates the local time dependence of the cut-off of 1.5 MeV protons during a period of little magnetic activity in September 1961. He also gives some information about the pitch angle distribution. He finds the cut-off at night to be $\sim 65^\circ$ and during the day $\sim 67^\circ$. A detailed look at his Figure 3, however, shows that on the day side the horizontal intensity cut-off is at a lower latitude than the vertical intensity cut-off, while on the night side both horizontal and vertical cut-offs occur at approximately the same latitude. Such an effect is in general agreement with the present model calculations.

Injun 3 observations [Harding, 1966] of low energy solar protons on September 21, 1963 show a much more striking difference in geomagnetic cut-offs for particles at pitch angles near 90° and near 0° at a local time of ~ 0800 and a negligible difference at a local time of ~ 1600 . However it should be pointed out that these Injun 3 measurements were taken during the magnetic storm of September 21-22, 1963 when the configuration of the magnetosphere

may have been significantly different from the model used in this paper. In addition, the temporal variations which are evident in the magnetograms for that time would contribute to the changing of particle pitch angles and thereby cloud the picture.

SUMMARY AND DISCUSSION

The results are summarized in the abstract (q.v.).

Although this study was undertaken independently of that of Reid and Sauer [1967] and is different in detail, it yields broadly concordant results in emphasizing the essential role of the magnetospheric tail in providing access to the earth for low energy (~ 1 MeV) solar protons. Additional insight is provided on the matters of diurnal variation of cut-offs and of permitted pitch angles at satellite altitudes. A definitive test must await more comprehensive particle observations at times when the actual topology of the distant geomagnetic field is being determined simultaneously or can be inferred reliably from systematic study of its relationship to other, more easily observed geomagnetic characteristics.

ACKNOWLEDGEMENT

I wish to express my gratitude to Dr. J. A. Van Allen for suggesting this study on the basis of the Injun 3 observations and for making many helpful suggestions. The research was begun with the financial aid of the National Aeronautics and Space Administration under research Grant NsG-233-62 to the University of Iowa. It was concluded while I was being supported by NASA as a National Academy of Sciences--National Research Council Post-Doctoral Resident Research Associate at Goddard Space Flight Center.

REFERENCES

- Akasofu, S.-I., W. C. Lin, and J. A. Van Allen, The Anomalous Entry of Low Rigidity Solar Cosmic Rays into the Geomagnetic Field, J. Geophys. Res., 68, 5327-5338, 1963.
- Gill, S., A Process for the Step-by-Step Integration of Differential Equations in an Automatic Digital Computing Machine, Proc. Cambridge Phil. Soc., 47, 96-108, 1951.
- Harding, R. C., Injun 3 Satellite Observations of Solar Protons During 1963, M.S. Thesis, University of Iowa, February 1966 (unpublished).
- Leinbach, H., D. Venkatesan, and R. Parthasarathy, The Influence of Geomagnetic Activity on Polar Cap Absorption, Planetary and Space Science, 13, 1075-1095, 1965.
- Maehlum, B., and B. J. O'Brien, Solar Cosmic Rays of July 1961 and Their Ionospheric Effects, J. Geophys. Res., 67, 3269-3279, 1962.
- Pieper, G. F., A. J. Zmuda, C. O. Bostrom, and B. J. O'Brien, Solar Protons and Magnetic Storms in July 1961, J. Geophys. Res., 67, 4959-4981, 1962.
- Reid, G. C., and H. H. Sauer, The Influence of the Geomagnetic Tail on Low-Energy Cosmic-Ray Cutoffs, J. Geophys. Res., 72, 197-208, 1967.
- Sauer, H. H., A New Method of Computing Cosmic-Ray Cutoff Rigidity for Several Geomagnetic Field Models, J. Geophys. Res., 68, 959-971, 1963.

Stone, E. C., Local Time Dependence of Non-Stormer Cutoff for
1.5 MeV Protons in Quiet Geomagnetic Field, J. Geophys. Res.,
69, 3577-3582, 1964.

Taylor, H. E., and E. W. Hones, Jr., Adiabatic Motion of Auroral
Particles in a Model of the Electric and Magnetic Fields
Surrounding the Earth, J. Geophys. Res., 70, 3605-3628,
1965.

FIGURE CAPTIONS

Figure 1. Field lines in the noon-midnight meridian of the model geomagnetic field. The axes are labeled in units of earth radii and the field lines are labeled by their co-latitude at the surface of the earth.

Figure 2. A north polar cap latitude-local time plot of the three distinct regions of accessibility or inaccessibility to 1.2 MeV protons which enter the magnetosphere from infinity. The slashed region is inaccessible to any such particles. The cross-hatched region is accessible only to particles whose pitch angles are near 90° at an altitude of ~ 2000 km. The open region including the pole is the "polar plateau", a region which is probably accessible to particles of all pitch angles from 0° to 90° . Latitude is in degrees. The dawn meridian is at 0600 hours and the dusk meridian at 1800 hours.

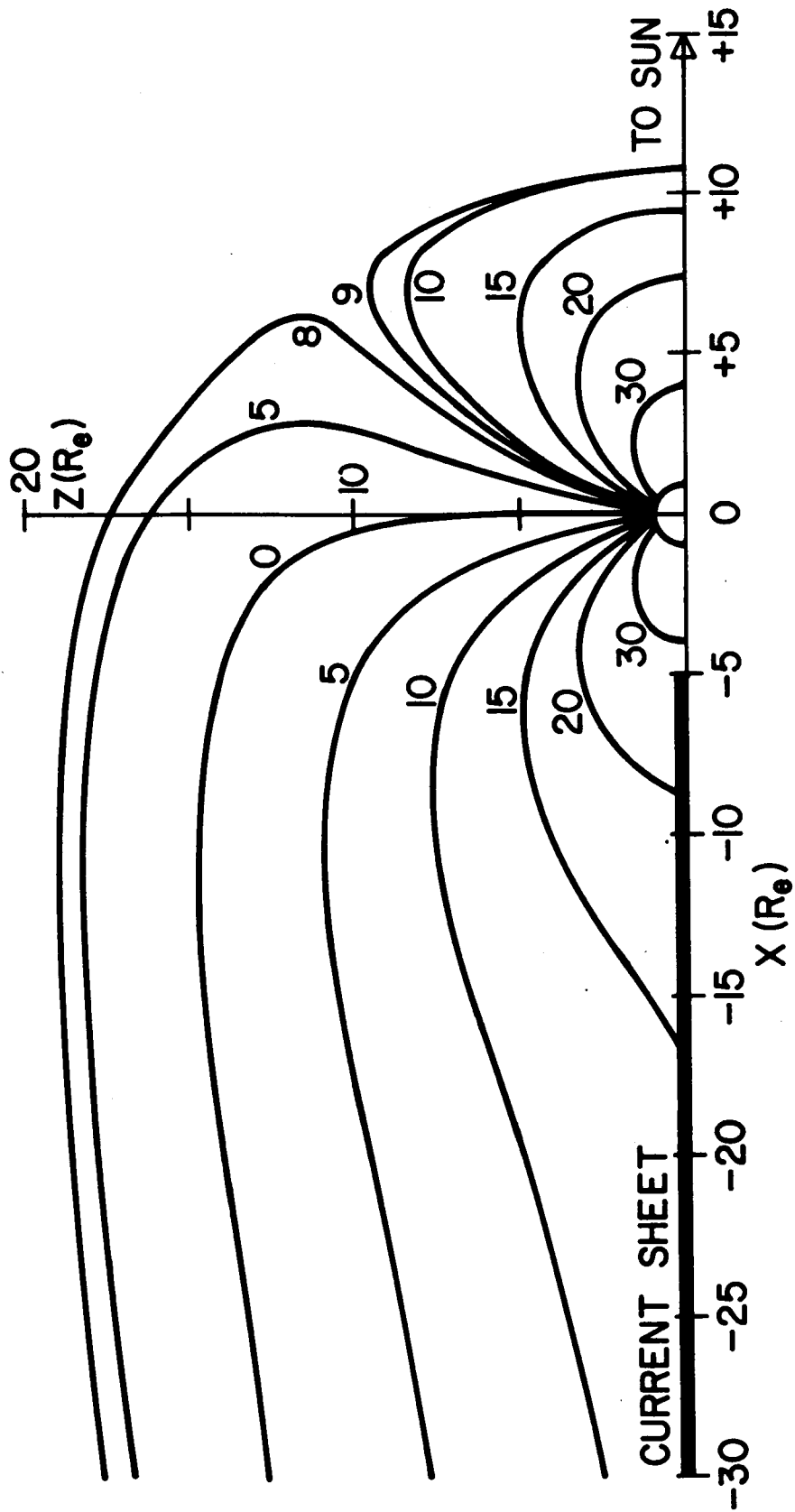

FIGURE 1

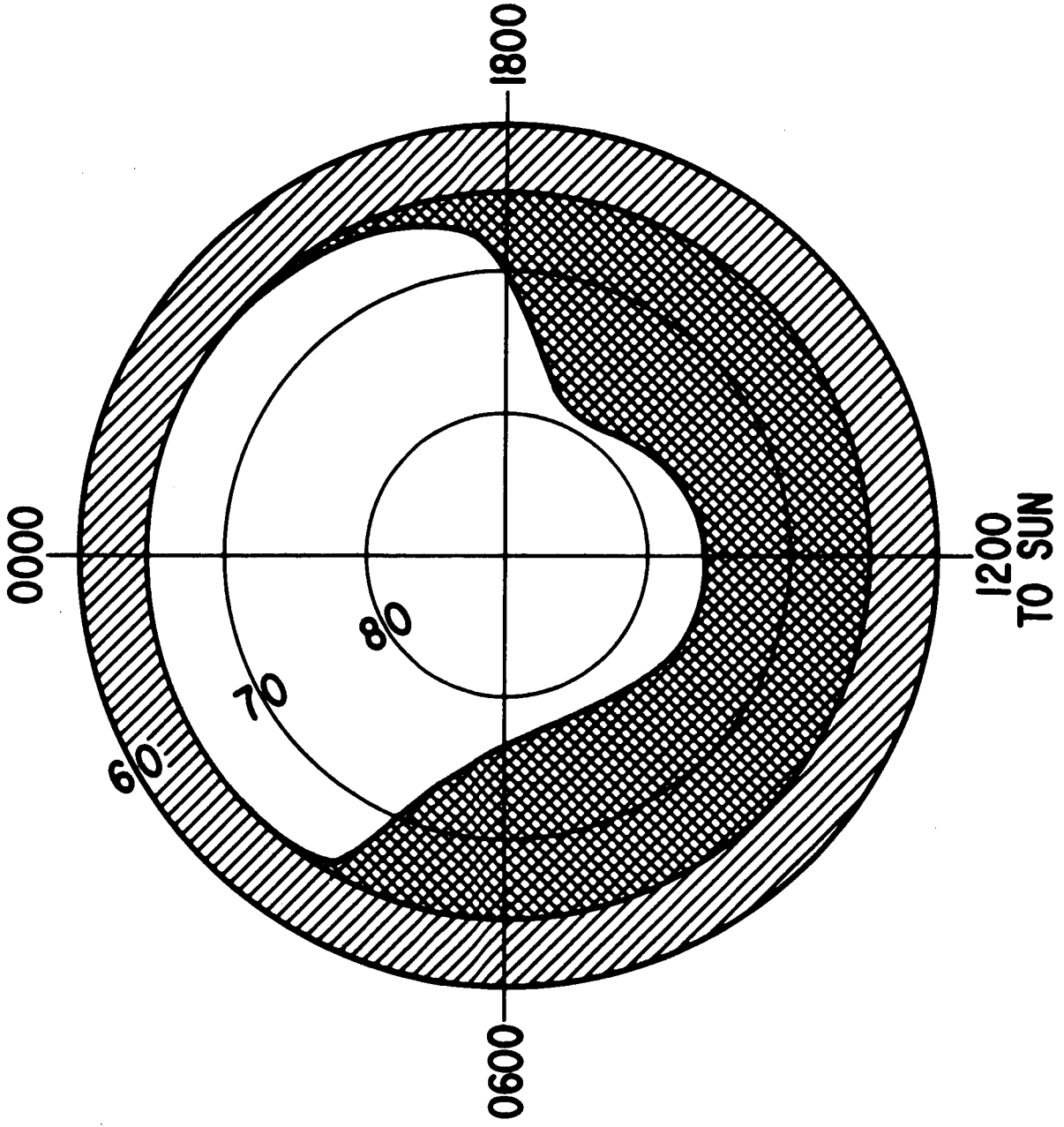

FIGURE 2