

**NASA CONTRACTOR
REPORT**

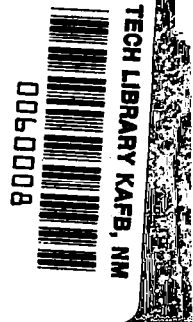

NASA CR-



NASA CR-805

LOAN TO: *MEMPHIS*
ADP: *...*
KIRTLAND: *...*

THE OCULOMETER

by John Merchant

Prepared by
HONEYWELL INC.
Boston, Mass,
for



THE OCULOMETER

By John Merchant

Distribution of this report is provided in the interest of information exchange. Responsibility for the contents resides in the author or organization that prepared it.

Prepared under Contract No. NASw-1159 by
HONEYWELL INC.
Boston, Mass.

for

NATIONAL AERONAUTICS AND SPACE ADMINISTRATION

FOREWORD

This report covers two phases of activity. In Phase I, the basic oculometer was designed, fabricated, and tested. In Phase II, certain modifications and additions were made, based on the experience gained in Phase I.

Section 2 reviews Phase I briefly, dealing exclusively with the chronological development of the work. More detailed information may be found in the Interim Technical Report, Oculometer, Contract NASW-1159, Honeywell Document 66-4, January 31, 1966.

Sections 3 and 4 describe the Phase II work. Section 5 reports the chief results of the applications study, which is discussed in detail in Appendix A.

Section 6 summarizes the main conclusions derived from Phase II and outlines recommendations for further work.

The valuable contributions to this program from numerous individuals within NASA and Honeywell are gratefully acknowledged. In particular, Kenneth A. Mason (Systems), Parker W. Johnson (Mechanical), and Norman B. Stetson (Electronics) participated in the work performed at Honeywell. Mr. Lowell O. Anderson and Dr. William Z. Leavitt of NASA were technical monitors. Mr. William Allen, also of NASA, provided stimulating ideas in the early discussions of this program.

TABLE OF CONTENTS

SECTION		PAGE
1	INTRODUCTION	1
2	ORIGINAL OCULOMETER CONCEPT	4
2.1	SYSTEM DESCRIPTION	4
2.2	PRINCIPAL RESULTS OF THE FIRST PHASE	5
3	PHASE II OF THE PROGRAM--A DESCRIPTION OF THE PRESENT FORM OF THE OCULOMETER	12
3.1	SUMMARY	12
3.2	GENERAL CONFIGURATION OF THE OCULOMETER	13
3.3	OPTICAL DESIGN	13
3.4	ELECTRONICS DESIGN	26
3.5	MECHANICAL DESIGN	37
4	EXPERIMENTAL RESULTS	52
4.1	OCULOMETER CHARACTERISTICS	52
4.2	MEASUREMENT OF EYE DIRECTION	67
4.3	ACQUISITION SYSTEM	76
4.4	AUTOMATIC PUPIL ACQUISITION LOOP	77
4.5	OPTICAL CHARACTERISTICS	78
4.6	SUMMARY OF RESULTS	78
5	RESULTS OF THE APPLICATIONS STUDY	95
5.1	SUMMARY	95
5.2	ASTRONAUT'S TRACKING TELESCOPE	95
5.3	ASTRONAUT MANEUVERING UNIT (AMU)	96
5.4	MEASUREMENT APPLICATIONS	97
5.5	RECOMMENDATIONS	98
6	CONCLUSIONS AND RECOMMENDATIONS	101
6.1	SUMMARY	101
6.2	CONCLUSIONS	102
6.3	RECOMMENDATIONS	105

		PAGE
APPENDIX A	OCULOMETER APPLICATIONS	A-1
1.	INTRODUCTION	A-1
2.	LIST OF APPLICATIONS	A-4
3.	APPLICATION ANALYSIS	A-15
4.	INSTRUMENT DESIGN	A-51
5.	REFERENCES	A-59
APPENDIX B	GEOMETRY OF EYE MEASUREMENT TECHNIQUE	B-1

SECTION 1 INTRODUCTION

The oculometer has been developed at the Honeywell Radiation Center to the stage of an engineering feasibility breadboard. One objective of this program is to make it possible for man to control a machine by eye, * instead of by conventional hand (manual) control.

The practical implementation of eye control requires, in the first place, a device that can measure the direction of pointing of the eye in two dimensions and in real time, and that can be used under operational, as distinct from laboratory, conditions. Specifically, the oculometer should interfere as little as possible with the normal activities of a subject. None of the eye direction measuring techniques presently known can be considered entirely satisfactory for such operational use. The development of the oculometer has been undertaken in order to fulfill this requirement.

In addition to its intended use for eye control, the oculometer may find application simply as a measuring device with no control action involved. The oculometer's ease of operation and minimum interference with a subject could make possible more extensive use of eye direction measurements for research, physiological and psychological monitoring, and diagnosis.

*The highly developed neuromuscular (oculomotor) system responsible for the motion and control of the eye in its socket appears as an attractive alternative (to the hand) as a medium for control when the human must perform a high-speed pointing or visual tracking task.

The principle of operation of the oculometer is that eye direction, relative to a beam of collimated light incident on the eye, is approximately proportional to the position of the corneal reflection of that light, relative to the center of the pupil. The advantages of this basic method (similar to that used by Rashbass and Westheimer*) are that it involves electro-optical sensing of the pupil area of the eye, which is always visible when the subject is seeing, and that it is largely insensitive to lateral displacements of the head relative to the oculometer. This latter is due to the fact that the virtual reflection of the external light source is formed approximately in the plane of the pupil, so that there is very little parallax between the virtual reflection and the center of the pupil.

The hardware that has been developed is a telescopic oculometer in which eye direction is measured as the subject looks through an eyepiece at the viewed scene.** Provided only that the subject positions his eye accurately enough to see through the eyepiece (i. e., so that the entrance pupil of his eye overlaps the exit pupil of the eyepiece), the oculometer is able to track his eye and measure its direction of pointing relative to the eyepiece. The

*C. Rashbass and G. Westheimer, "Disjunctive Eye Movements," J. Physiol. (1961), p. 159.

**Another possible configuration is the head-mounted oculometer. In this form there would be no eyepiece in front of the eye. The subject's eye direction would be measured while permitting him normal, naked-eye vision through a transparent curved visor located in front of his eyes.

measurement is essentially independent of the lateral (as distinct from angular) position of the eye. For this reason, no bite plate or other rigid clamping of the skull is necessary.

In the telescopic oculometer, the eyepiece not only serves the normal visual function, but also directs a collimated beam onto the eye as well as imaging an area about 0.75 inch square around the eye onto the photocathode of an image dissector tube. The image dissector scans around the pupil/iris boundary and also around the corneal reflection in a 120 cps time-division-multiplex scan. Scan position error information is obtained by quadrature demodulation of the two sinusoidal signals derived from the image dissector output. These error signals are then applied to correct the position of the two scans. Eye direction is calculated as a linear combination of the corneal reflection scan position and a small multiple of the pupil scan position (parallax correction).

The oculometer operates in basically two modes--acquisition and track. When the eye is first placed at the eyepiece, the 120 cps rotating scan is suppressed and replaced by a coarse raster scan designed to acquire the black pupil and bright corneal reflection. When this detail has been acquired, the system is automatically switched to the track mode, in which continuous eye direction measurements are made as described above. Should loss of track occur for any reason (e. g. , because of blink), the system will automatically revert to the acquisition mode until track is regained.

SECTION 2

ORIGINAL OCULOMETER CONCEPT

2.1 SYSTEM DESCRIPTION

In the original system concept, the direction of the eye is measured as it looks through a standard telescopic system consisting of an eyepiece and an objective lens, while at the same time it is irradiated with light from a bright spot on a cathode ray tube (CRT). The light from the CRT is reflected into the eyepiece and onto the eye via two beam splitters. As the spot of light moves over the surface of the CRT, the direction of light incident on the eye varies over a range of ± 20 degrees in two dimensions. For a given position of the spot on the CRT, all the light incident on the eye is parallel.

The corneal reflection of the light from the CRT will appear somewhere within the pupil area of the eye. The pupil area of the eye is imaged onto the photocathode of a scanning photomultiplier (PM) tube (which is essentially an image dissector).

The electronics system senses the pupil/iris boundary of the eye and the position of the corneal reflection relative to the center of the pupil. If the reflection is not at the center of the pupil, the electronics unit generates an error signal; this is applied to the deflection circuits of the CRT to drive the spot (i. e. , the corneal reflection) to the center of the pupil. Eye direction is then proportional, to first order, to the direction of the CRT light incident at the eye relative to the axis--i. e. , proportional to the position of the spot of light on the CRT. (See Appendix B.)

To achieve the program objectives at minimum cost, the simplest possible mechanical design concepts were utilized. The optical system was mounted on low-cost Ealing optical benches. The general arrangement is illustrated in Figure 2. 1. The heart of the oculometer is the black box, shown in Figure 2. 2, mounted on a table at the intersection of the two optical benches. This box contained the eyepiece, the beam splitters, the auxiliary lenses, and the scanning PM tube with its preamplifier. The objective lens for the monocular system was mounted on a carriage at one end of one of the optical benches. The CRT was mounted on a table at the end of the other optical bench.

The electronics unit was a separate console (Figure 2. 3), with connections running from the PM tube and to the CRT. Honeywell general purpose laboratory power supplies were used to power both the electronics and the PM tube.

2. 2 PRINCIPAL RESULTS OF THE FIRST PHASE

The pupil/iris boundary of the human eye was successfully tracked. Two typical eye tracking records (of the position of the pupil/iris boundary) are shown in Figures 2. 4 and 2. 5. These illustrate the excellent time response, low noise level, and repeatability of the tracking system.

Two important technical problems existed at the conclusion of Phase I.

First, the useful size of the PM tube photocathode proved to be smaller than expected.

The specification for this tube refers to a maximum usable photocathode diameter of 0.75 inch. However, tests with the PM tube showed that photocathode sensitivity falls off rapidly beyond 0.20 inch from the center. According to the manufacturer, this is normal for the tube. Thus, the useful photocathode diameter was less than 0.50 inch. The effect was to restrict the area over which the eye could move and still be tracked.

Second, spurious reflections of the light from the CRT screen were formed by the various surfaces in the eyepiece. These reflections interfered with the tracking of the corneal reflection.

Antireflection coatings were applied to the eyepiece lenses, but failed to solve the problem. The eyepiece, a government surplus unit, was already coated, but not with the type of coating required in the present case.

A color chopping system was tried to provide a means of discriminating the true (corneal) reflection from the spurious (eyepiece) reflections. This also failed to solve the problem.

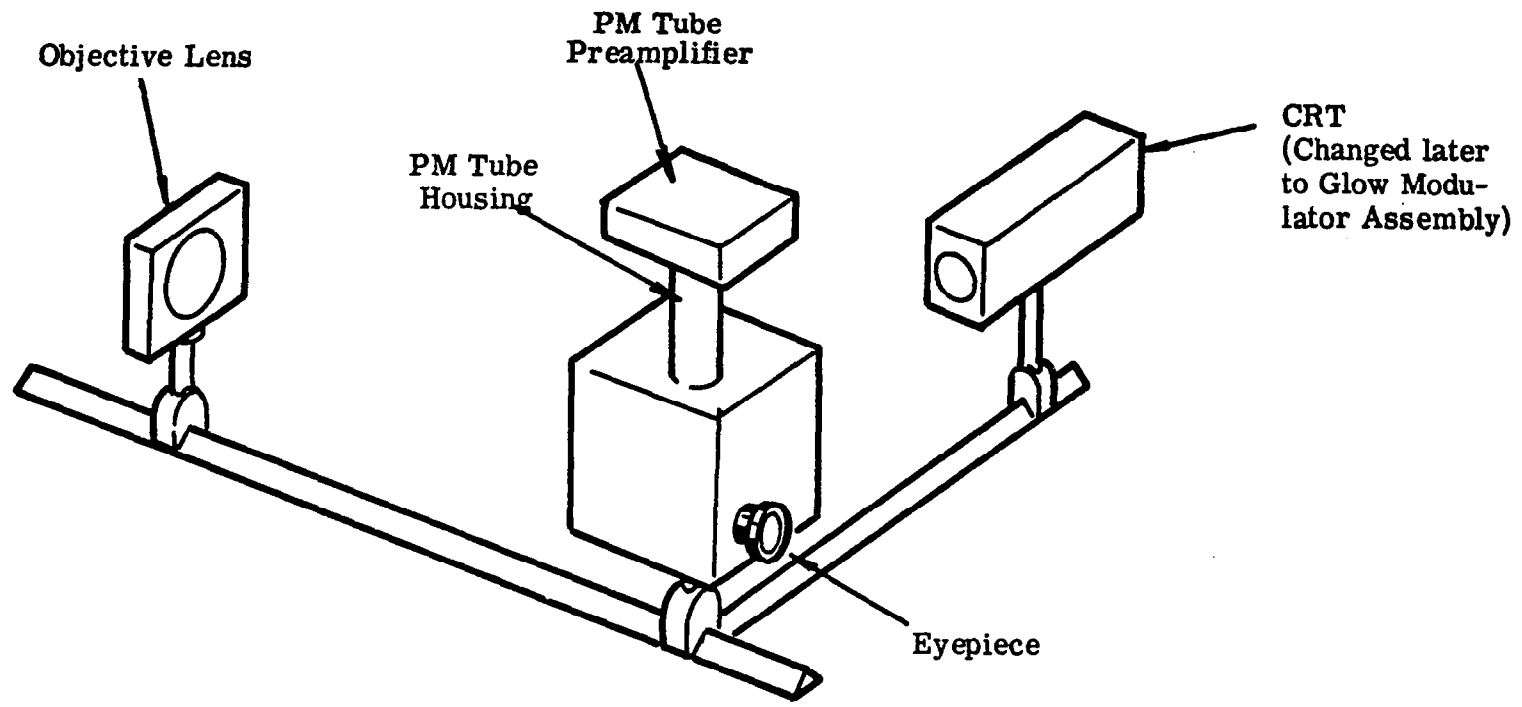

7

Figure 2.1 GENERAL VIEW OF OCULOMETER

PM TUBE PREAMPLIFIER

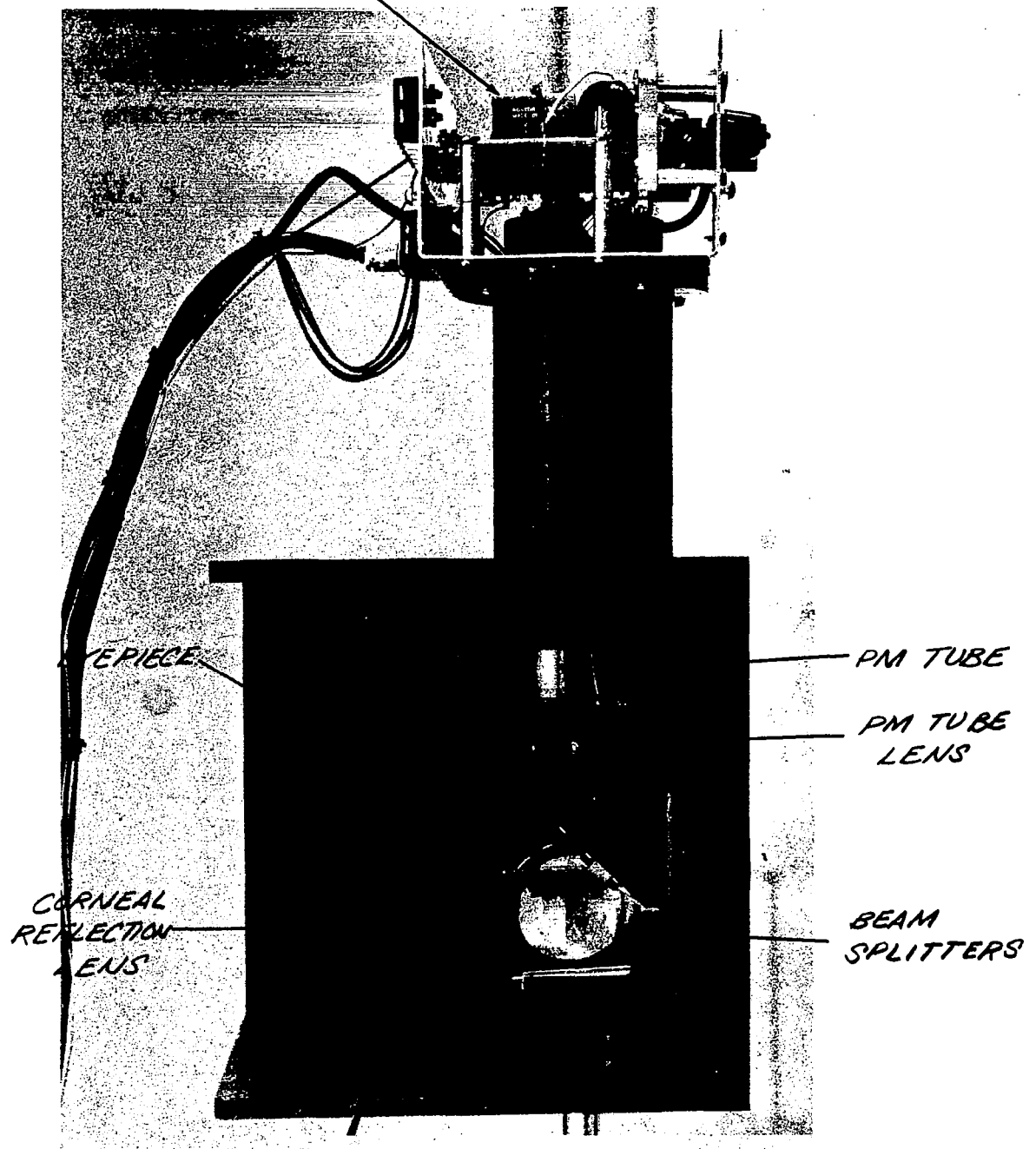

Figure 2.2 MAIN OPTICAL UNIT OF OCULOMETER

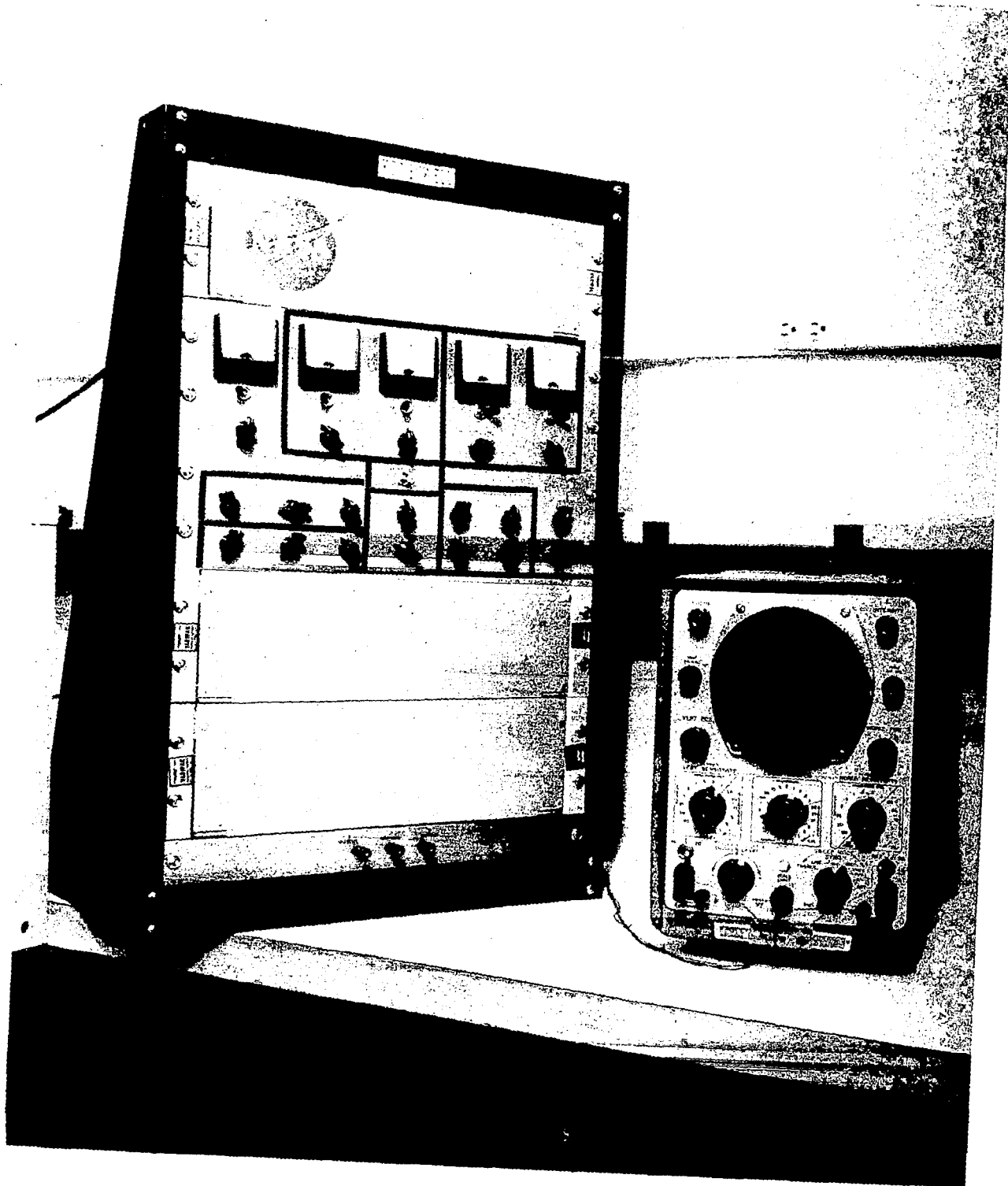

Figure 2.3 OCULOMETER ELECTRONICS PANEL

Horizontal Eye Motion

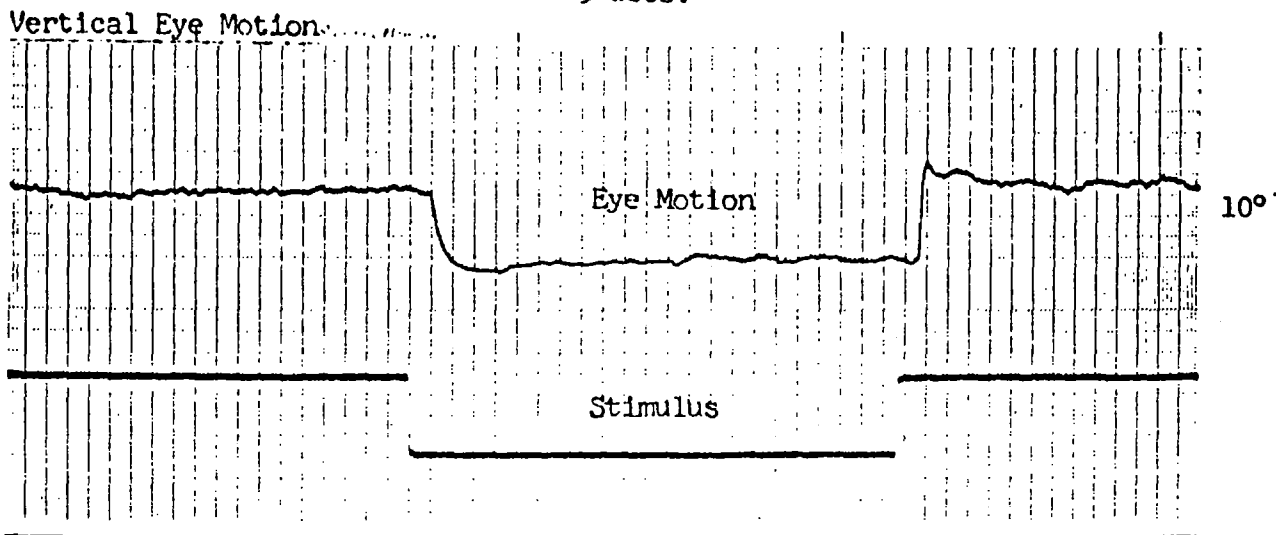
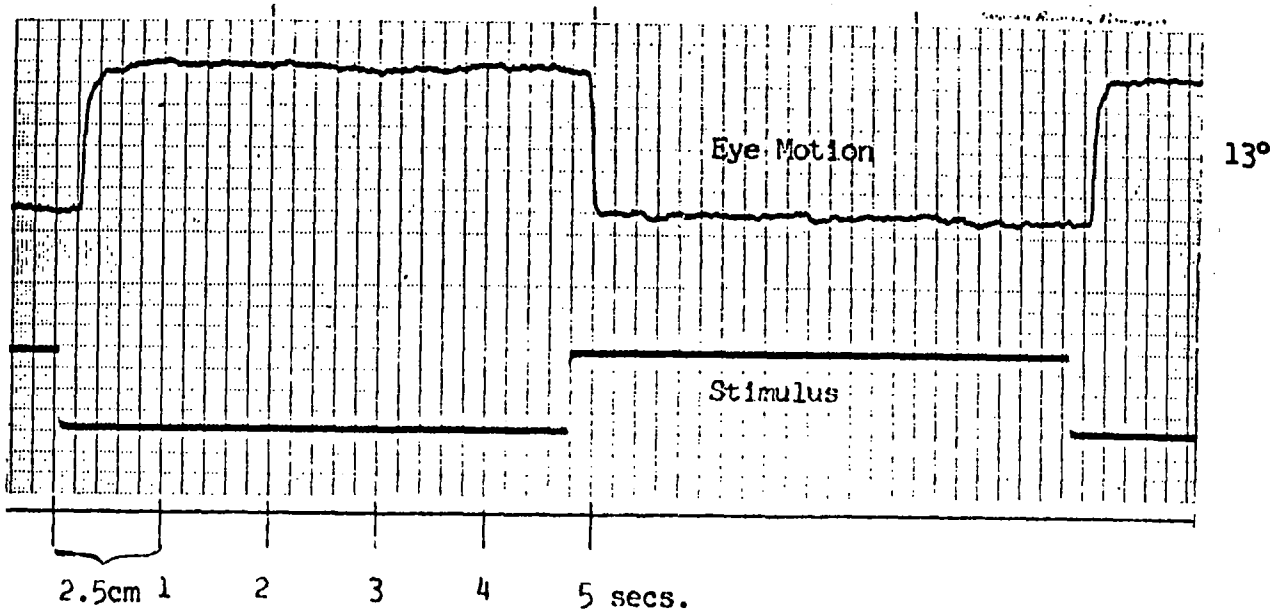

Figure 2.4 VERTICAL AND HORIZONTAL TRACKING OF PUPIL/IRIS BOUNDARY

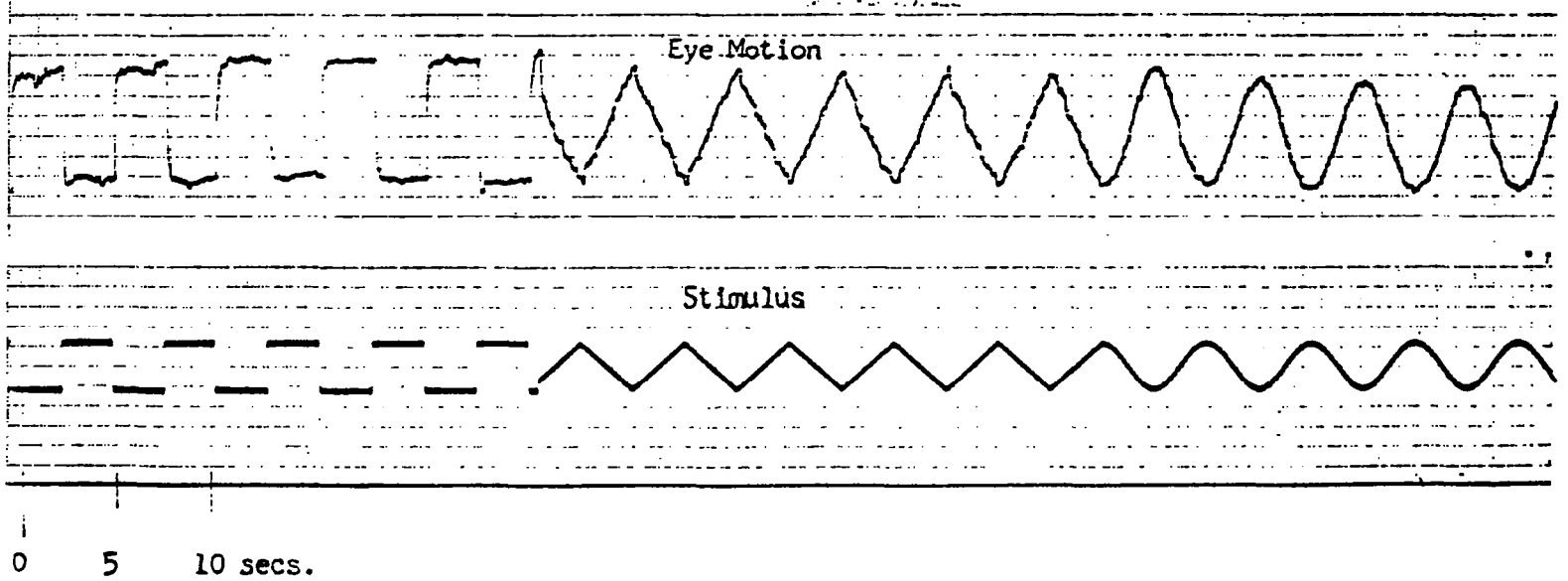

Figure 2.5 80 SEC CONTINUOUS TRACKING OF PUPIL/IRIS BOUNDARY OF HUMAN EYE

SECTION 3

PHASE II OF THE PROGRAM--A DESCRIPTION OF THE PRESENT FORM OF THE OCULOMETER

3.1 SUMMARY

Based on the results of the first phase of the program, it was decided to utilize a fixed source of internal light to form the corneal reflection. With this arrangement, eye direction would be proportional to the position of the corneal reflection within the pupil (Appendix B). This approach offered poorer linearity and accuracy than the original moving corneal light source, but it made it easier to achieve the primary objective of the program: acquisition and simultaneous tracking of the pupil/iris boundary and corneal reflection of the eye.

A polarization method of suppressing spurious reflections was successfully implemented.

The scanning PM tube (FW130) employed in Phase I was replaced by an image dissector (ID) tube (F4011). The optical characteristics of the ID proved to be satisfactory over the entire photocathode.

An automatic acquisition system was introduced into the electronics, whereby the pupil/iris boundary and corneal reflection were automatically acquired when the eye was placed near the eyepiece of the oculometer. This system also ensured that track would be regained automatically after a blink.

3.2 GENERAL CONFIGURATION OF THE OCULOMETER

The eye views through a 10X monocular consisting of an eyepiece and an objective lens (Figure 3.1). At the same time the eye is irradiated with collimated light from a glow modulator tube within the oculometer. This produces a corneal reflection (approximately in the plane of the pupil), the position of which relative to the center of the pupil is proportional to eye direction. The pupil area of the eye is imaged onto the photocathode of an ID tube. This tube measures the average intensity of a circular area of the image having a diameter of 2.5% of the total photocathode diameter. The position of this sampled area is controlled by currents in the ID deflection coils.

The electronics unit controls the ID scan and analyzes the ID output. It acquires and tracks the pupil/iris boundary and the corneal reflection. Eye direction is computed as a function of the position of the corneal reflection relative to the center of the pupil.

3.3 OPTICAL DESIGN

3.3.1 Lens System

The optical system of the oculometer must perform three distinct functions. First, it must provide the subject with normal monocular telescopic vision. Second, it must direct light onto the eye of the subject (as he looks through the eyepiece) from an internal fixed source, to form a corneal reflection within the pupil area. Third, it must form an image of the pupil area on the photocathode of the ID tube.

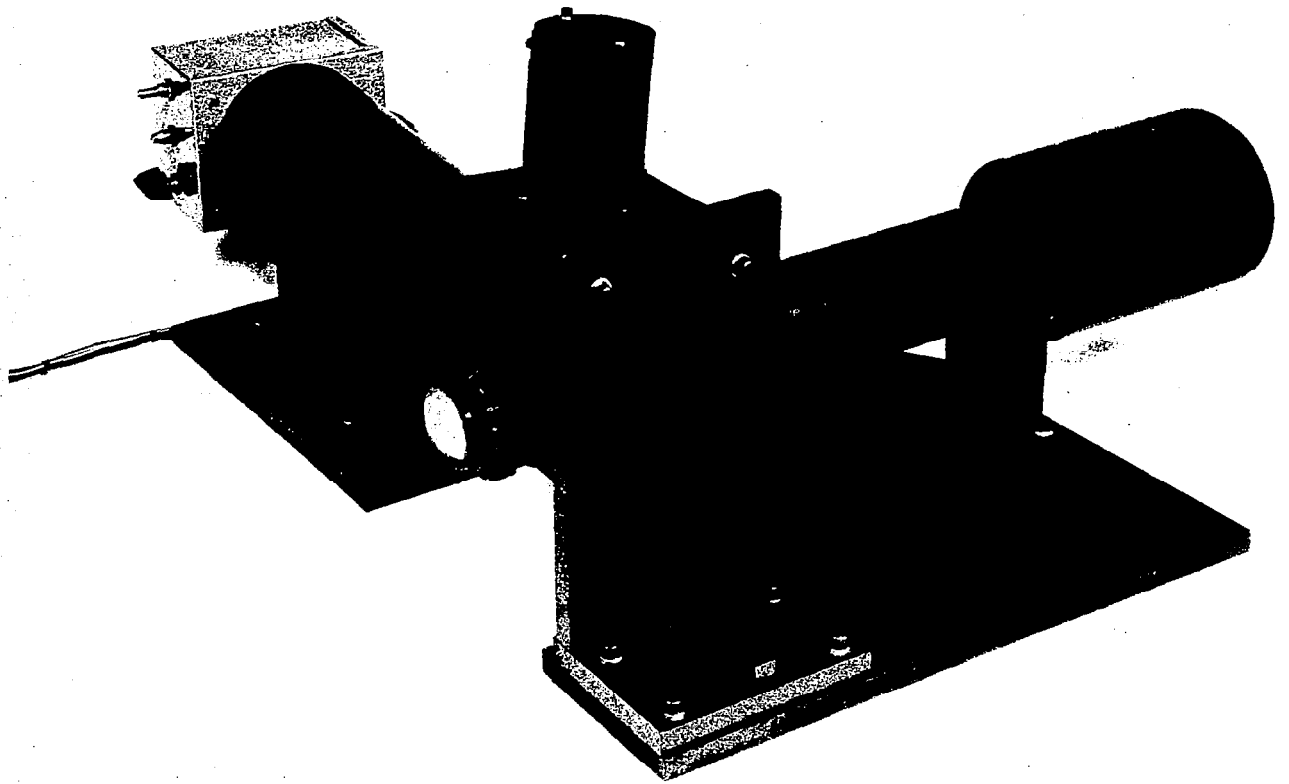

Figure 3.1 NASA/HONEYWELL OCULOMETER

In the normal monocular function of the oculometer, light from the viewed scene is directed onto the eye from the eyepiece as illustrated in Figure 3.2. It is important to note the position of the exit pupil in this diagram. Light from all parts of the viewed scene passes through the exit pupil. At other points of the optical axis, however, light from various points in the viewed scene passes through different positions in the space near the eyepiece. It is evident, therefore, that if the eye is to see easily over the wide field of view of the eyepiece, the entrance pupil of the eyeball must be close to the exit pupil of the eyepiece, as illustrated in Figure 3.3.

The diameter of the exit pupil chosen for the oculometer is approximately 5 millimeters (a standard exit pupil size for daylight viewing). This is larger than the entrance pupil of the eye for the normal levels of illumination which would be encountered in the use of this oculometer. It is sufficient to permit the eye to see the viewed scene clearly and brightly if the eye is located fairly accurately relative to the axis of the eyepiece. In other words, the restricted exit pupil of the telescopic function of the oculometer constrains the position of the eye somewhat near the optical axis of the eyepiece. It must be emphasized, however, that this constraint is imposed by any conventional monocular viewer.

Whenever the eye is looking through the eyepiece, the remaining parts of the oculometer optical system must ensure that:

1. the eye is adequately illuminated with radiation to form a corneal reflection.
2. the pupil area, for all realistic positions of the eye consistent with seeing through the telescope, is imaged onto the sensitive screen of the scanning ID tube (the nominal range of eye motions designed for was ± 20 degrees angular, in two dimensions, and ± 0.1 inch lateral, in three dimensions).

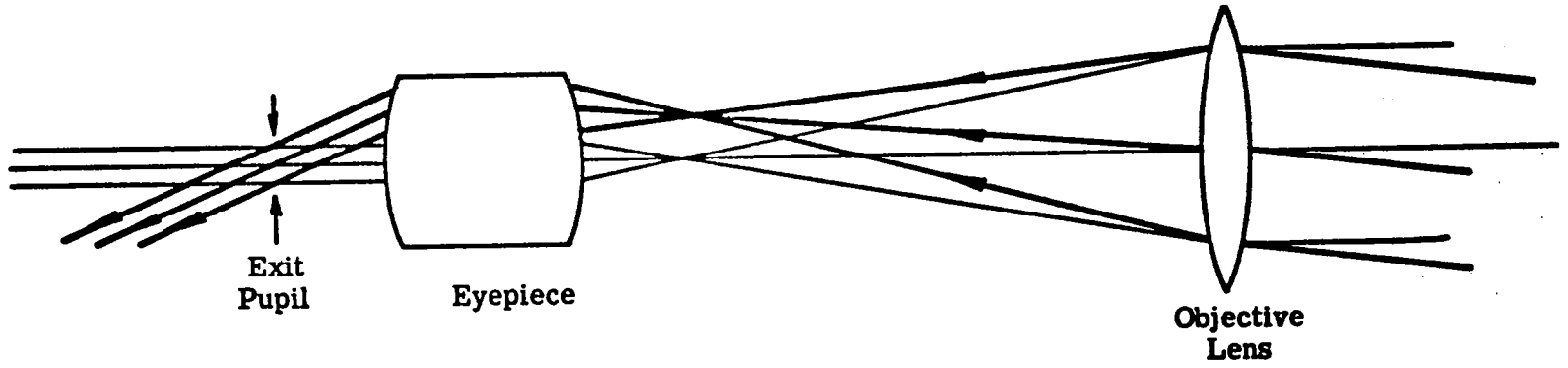

Figure 3.2 MONOCULAR SYSTEM

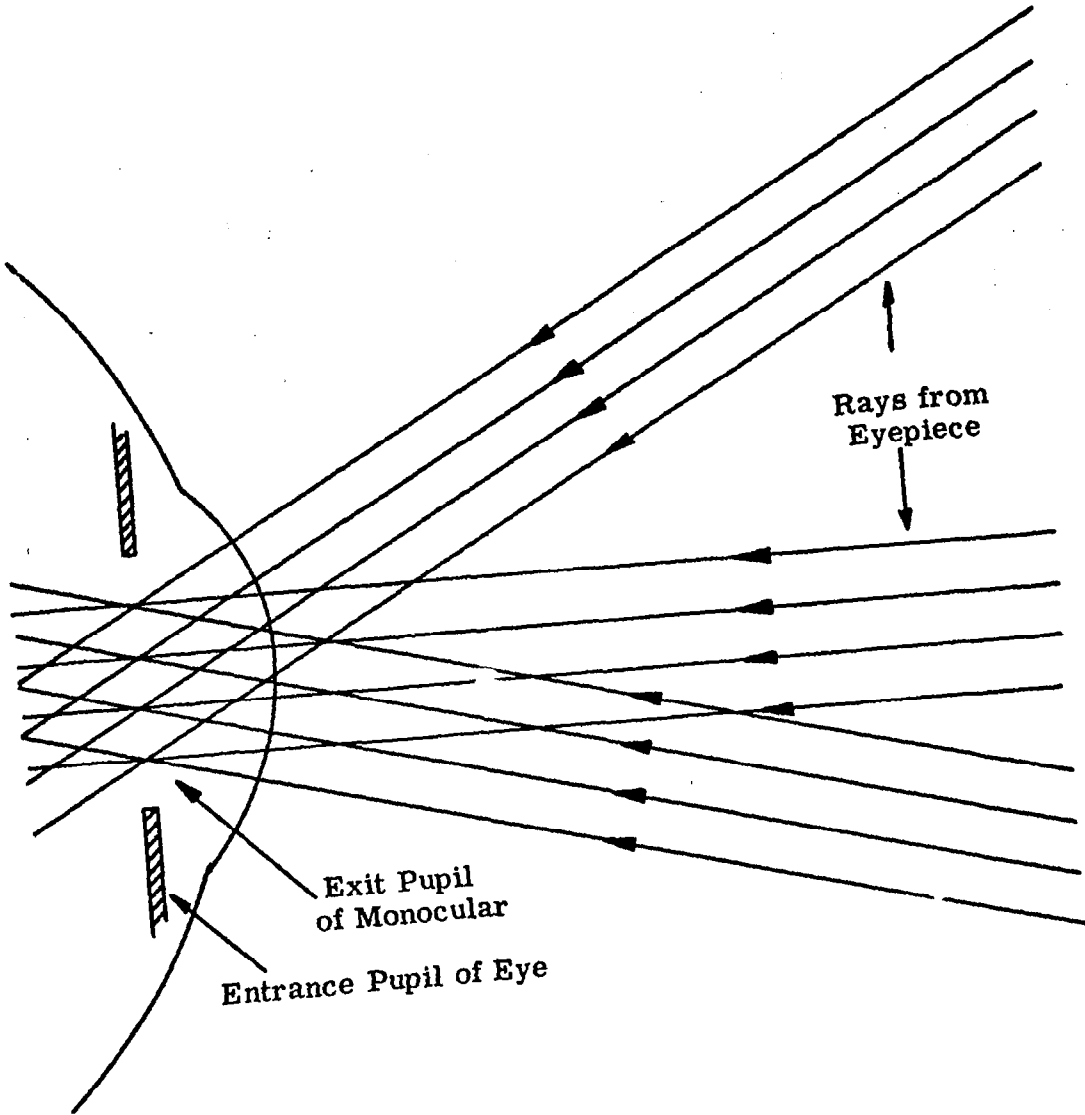

Figure 3.3 POSITION OF EYE RELATIVE TO MONOCULAR EXIT PUPIL

The basic optical design is shown in Figure 3.4.

The position of the exit pupil for the corneal reflection light must be such that the cornea of the eye will be adequately illuminated for all possible positions of the eye as it looks over a field of view of ± 20 degrees. The corneal light incident at the eye is collimated and is at 9 degrees to the axis of the oculometer. The reason for projecting the corneal light off-axis is that the two beam splitters on the other side of the eyepiece can then be physically separated (see Figure 3.5). This makes it easier to prevent radiation from the glow tube from reaching the ID.

The effective collecting aperture for the optical system that images the eye onto the photocathode of the ID tube is at infinity (telecentric system). A relatively small collecting aperture (approximately $f/7.5$) is used in order to provide good depth of focus for the optical system of the ID tube. This depth of focus is necessary because the eye is permitted an axial motion toward and away from the eyepiece of approximately ± 0.1 inch. For all positions of the eye within this tolerance, a reasonably sharp image of the eye should be formed by the optical system on the photocathode of the ID.

The three optical functions of the oculometer are essentially defined by the size and position of the exit pupil of the telescopic function, by the exit pupil for the incident light being directed onto the eye from the glow modulator tube, and by the size and position of the virtual aperture for the collecting ID tube optics. These three functions are accomplished by appropriate positioning of optical elements on the far side of the eyepiece (see Figure 3.6).

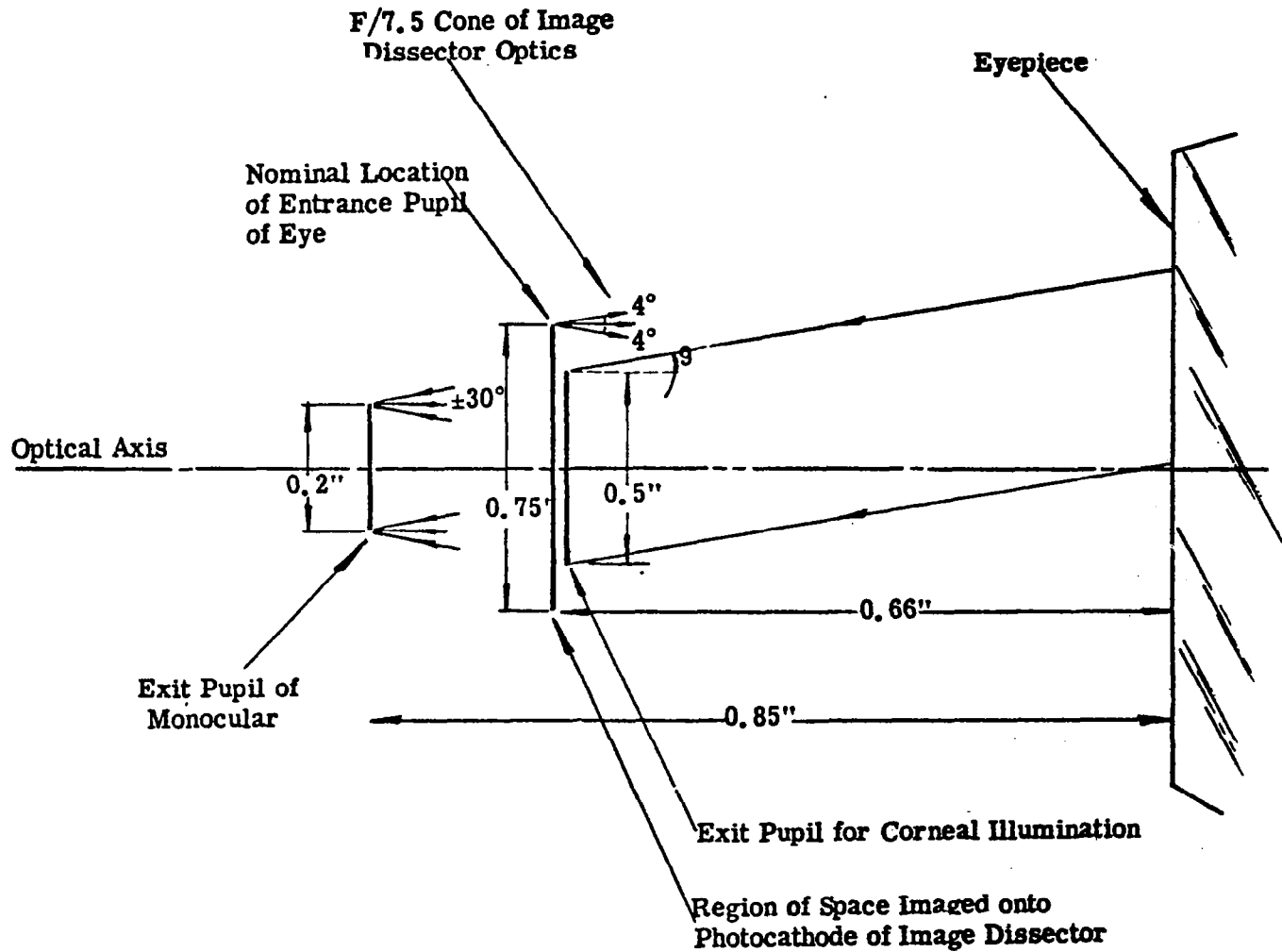

Figure 3.4 OPTICAL PARAMETERS IN RELATION TO EYEPIECE

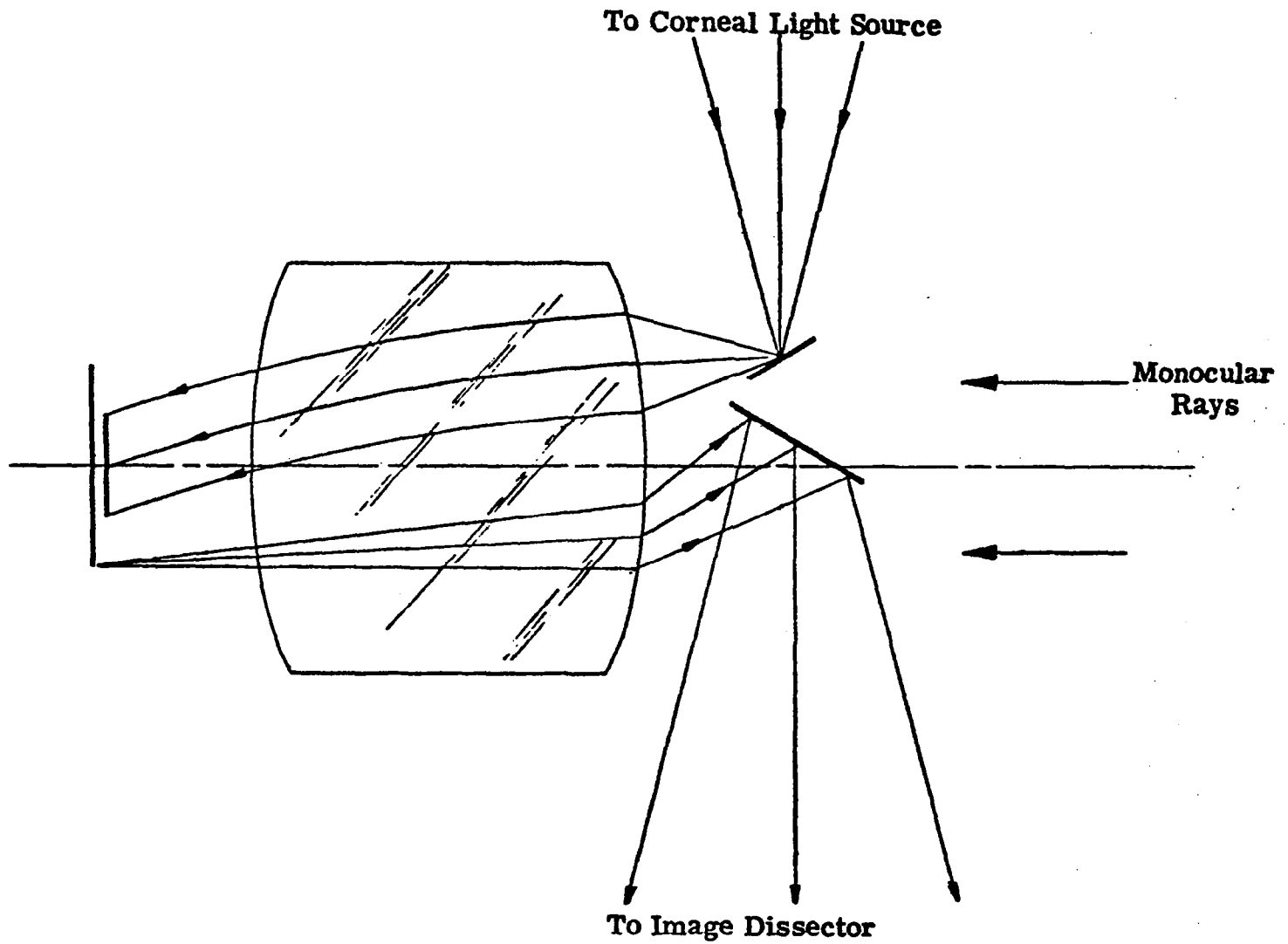

Figure 3.5 LOCATION OF BEAM SPLITTERS

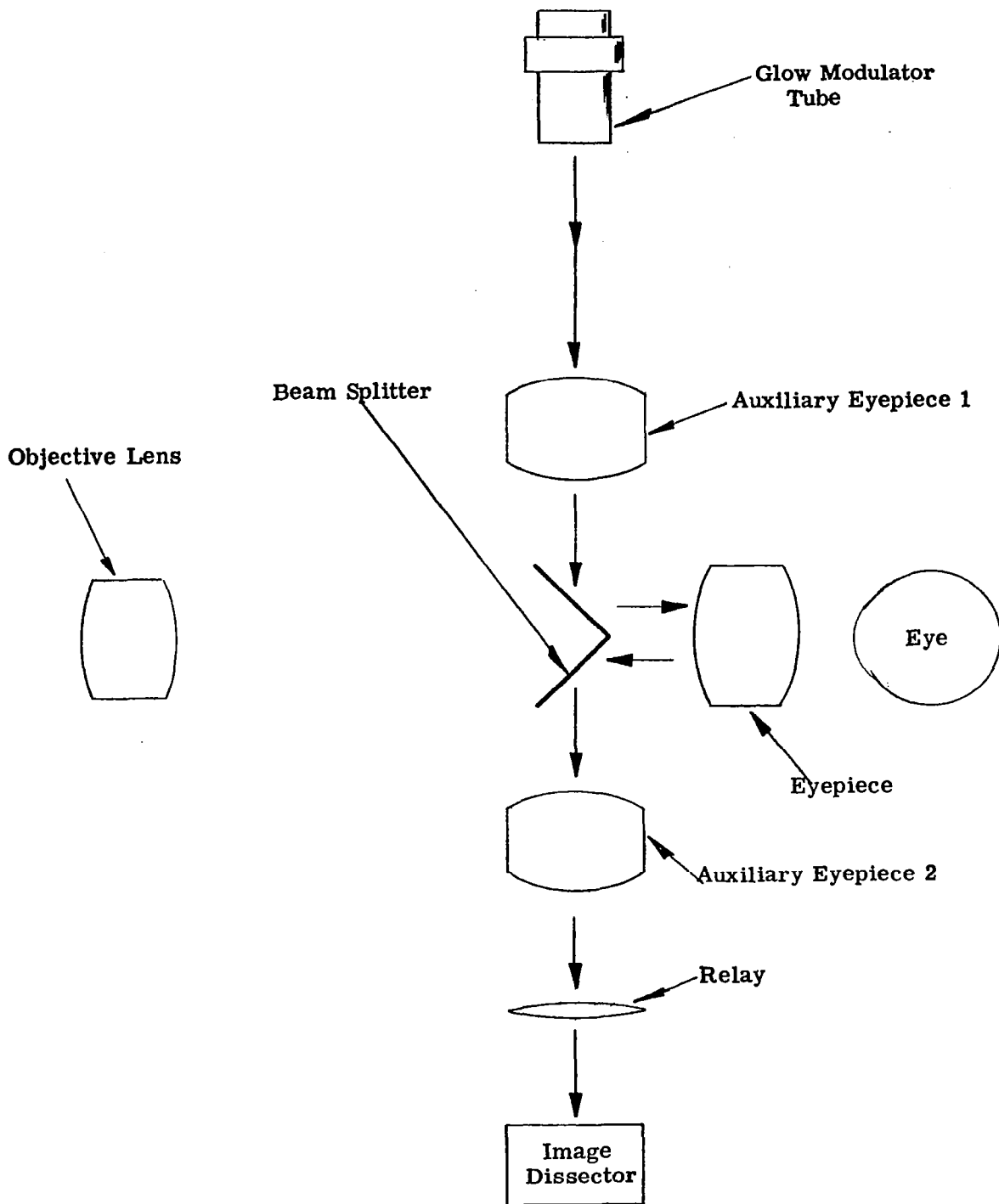

Figure 3.6 OCULOMETER OPTICAL SYSTEMS

The unfolded optical schematics for the ID and corneal illumination systems are shown in Figures 3.7 and 3.8. Three government surplus wide angle Erfle eyepieces were selected for the oculometer optical system. Exact ray traces were performed, by digital computation, using detailed design data for the eyepiece, for the three optical system functions described above. The auxiliary lens was designed, and its performance evaluated in the optical system, by ray tracing with the computer. The detailed optical design information relating to the eyepiece and the auxiliary lens is given below.

Erfle Eyepiece

Refer to Figure 3.9 for nomenclature (units are inches):

<u>Surface</u>	<u>Clear Aperture</u>	<u>Radius</u>	<u>Curvature</u>	<u>Thickness</u>	<u>Glass Type</u>
1	1.711	-6.347	-.1575548	.067	617366
2		1.790	.5586592	.572	517645
3		-1.790	-.5586592	.020	Air
4	1.720	2.138	.4677268	.611	517645
5		-1.422	-.7032349	.109	649338
6		-3.492	-.2863688	.016	Air
7	1.414	1.707	.5858231	.565	517645
8		-1.140	-.8771930	.087	649338
9		-2.803	-.3567606	.657	Air

Image Dissector Relay Lens

Refer to Figure 3.9 for nomenclature (units are inches).

1	.200	.700	1.429	.200	SK-16
2	.200	-.700	-1.429	.200	

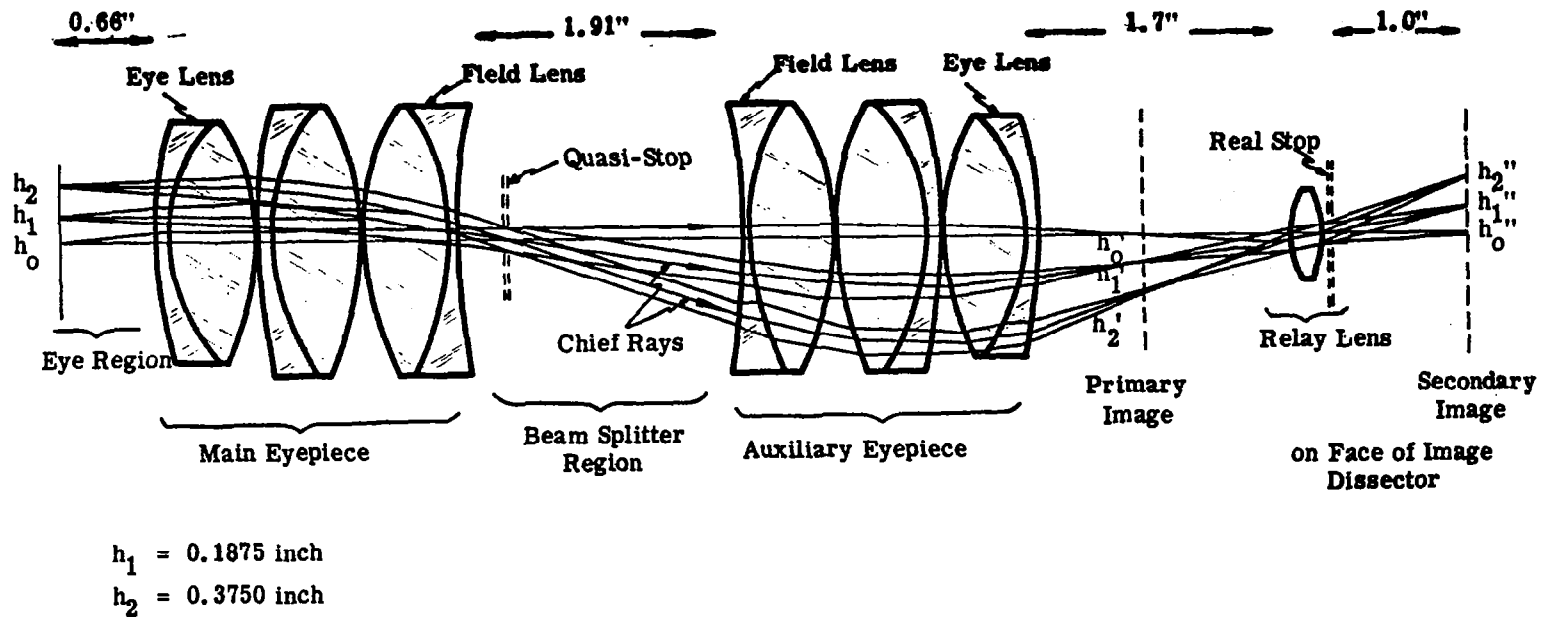

Figure 3.7 IMAGE DISSECTOR SYSTEM (UNFOLDED)

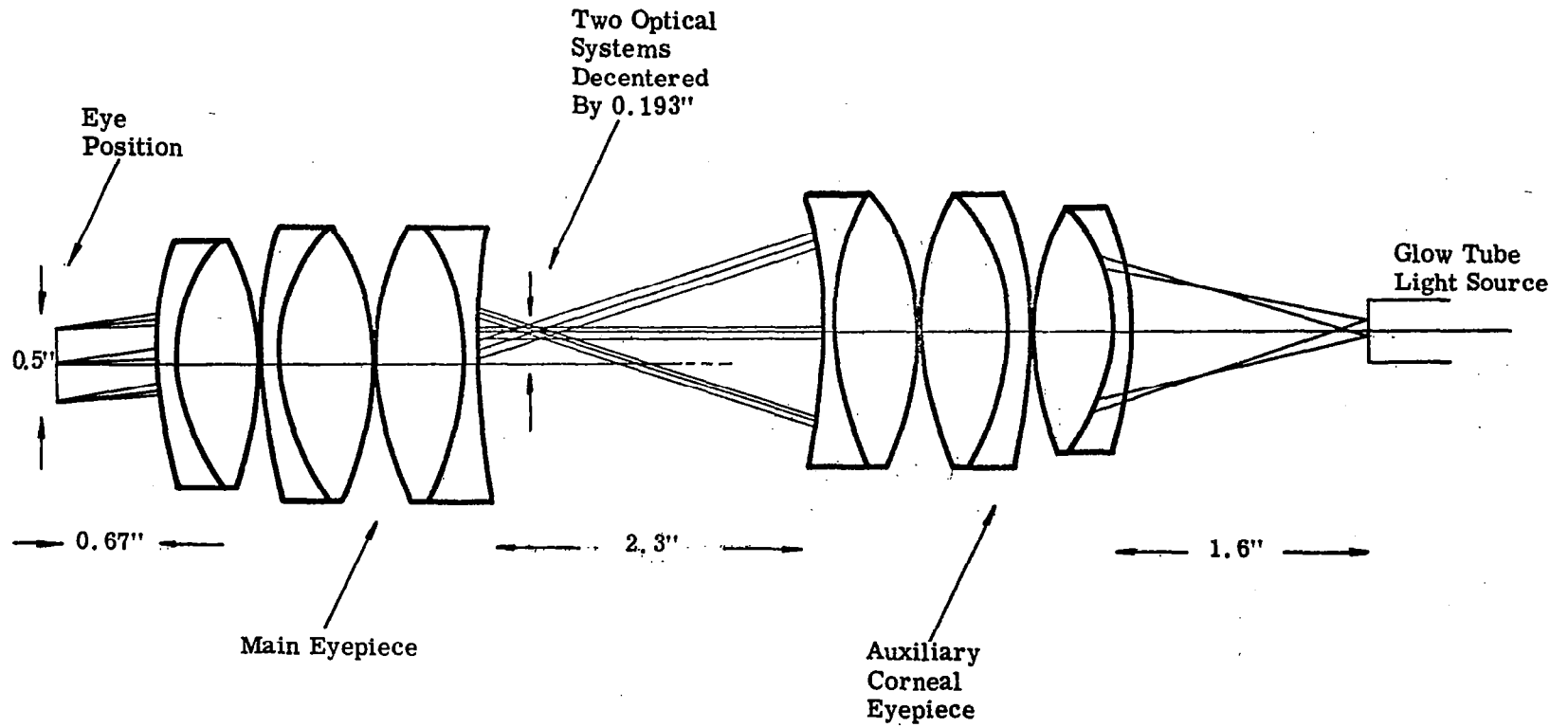
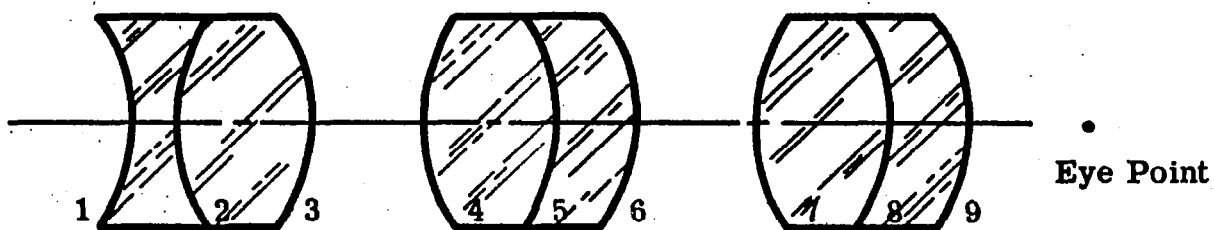
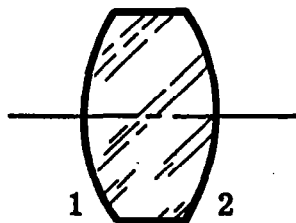

Figure 3.8 CORNEAL ILLUMINATION SYSTEM (UNFOLDED)



ERFLE EYEPIECE



ID TUBE LENS

Figure 3.9 OCULOMETER LENSES

3.3.2 Polarization System

The corneal light source is a glow modulator tube, as shown in Figure 3.10. The light from the tube is linearly polarized in the H direction. A linear polarizer in the V direction (90 degrees to H) is placed in the ID optical path to attenuate (by a factor of the order of 100) light from the glow tube coming in via reflections in the eyepiece. A suitably oriented quarter wave plate between the eye and the eyepiece, however, rotates by 90 degrees the plane of polarization of the primary glow tube light reflected off the cornea of the eye. Thus the V linear polarizer in the ID path does not attenuate the true corneal reflection. The glow tube is switched on and off at a 14 kc rate so that the corneal reflection signal can be discriminated by suitable electrical filters in the electronics.

3.4 ELECTRONICS DESIGN

3.4.1 Tracking System

The primary function of the electronics is to track the corneal reflection and pupil/iris boundary. Eye direction is computed as a function of the position of the corneal reflection relative to the center of the pupil.

The tracking task can be described entirely in terms of the optical image formed on the photocathode of the ID tube. The pattern in this image that is used in the tracking system is:

1. the boundary between the black, circular pupil area and the bright iris.
2. the bright corneal reflection spot within the pupil.

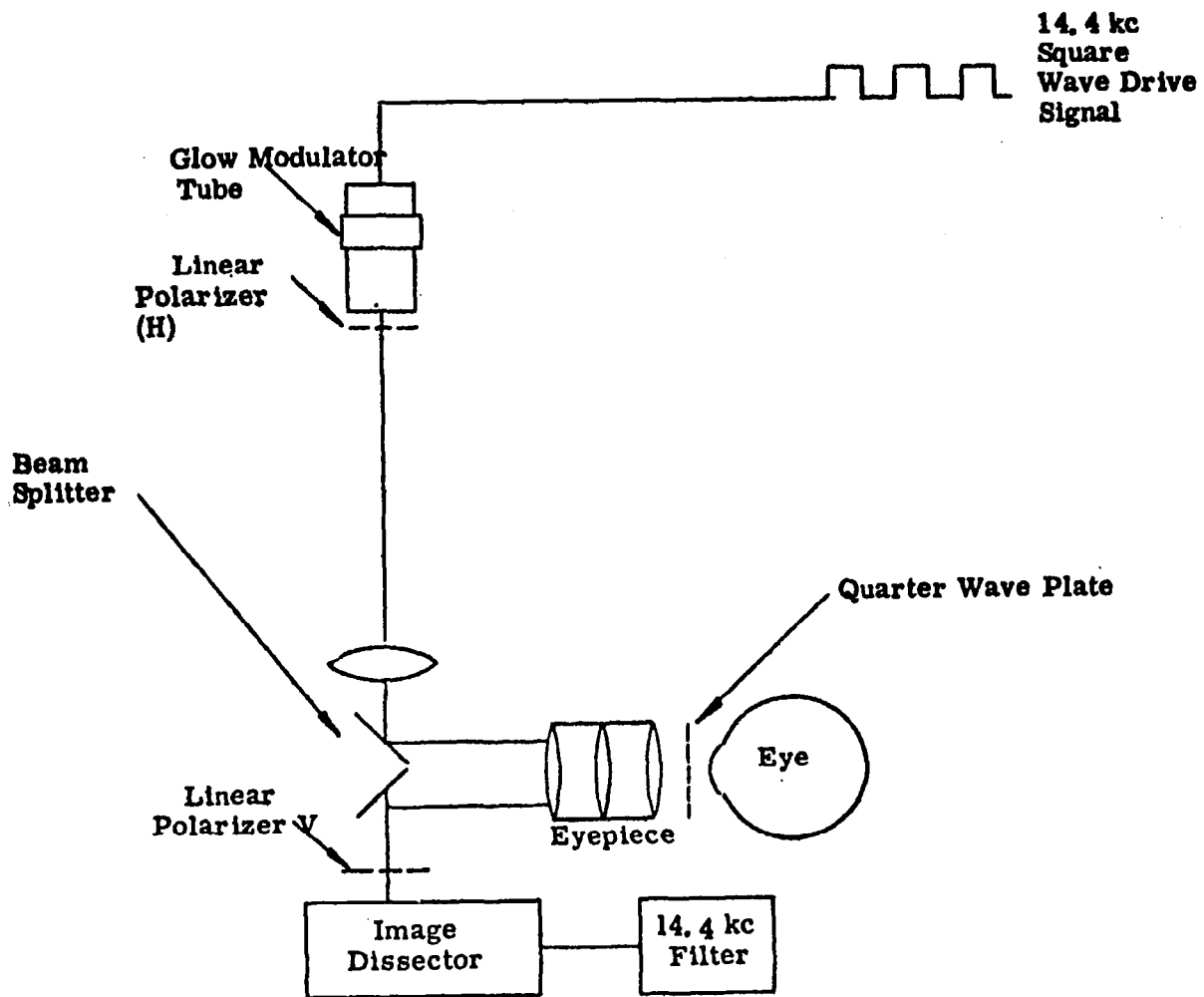

Figure 3.10 POLARIZATION CHOPPER

This pattern may be located anywhere on the photocathode area (see Figure 3.11).

The electrons accelerated from the photocathode are focused by a magnetic lens system onto an aperture plate. This plate has only a small, clear, circular hole through which electrons may pass onto a multiplier section of the tube (see Figure 3.12).

The electron image may be laterally deflected, in two dimensions, relative to the aperture plate, by a magnetic deflection yoke on the outside of the tube. Thus, selected portions of the electron image can be moved onto the clear portion of the aperture plate. This action may be most easily described in terms of (virtual) motion of the clear part of the aperture plate over the pupil area of the eye.

Figure 3.13 shows an aperture scan pattern, rotating at 120 rps, designed to locate the pupil position. If the pupil is not in the nominal position, a 120 cps sinusoidal component will appear in the output of the ID tube as a result of the scan. The amplitude and phase of this 120 cps component will define the required vector position. Pupil position information is used to center the aperture scan right over the image of the pupil.

Figure 3.14 shows a scan pattern designed to track the position of the corneal reflection spot. If the corneal spot is not at the center of the aperture scan pattern, a 120 cps component will appear in the output of the ID tube. The amplitude and phase of this component will define the required vector position.

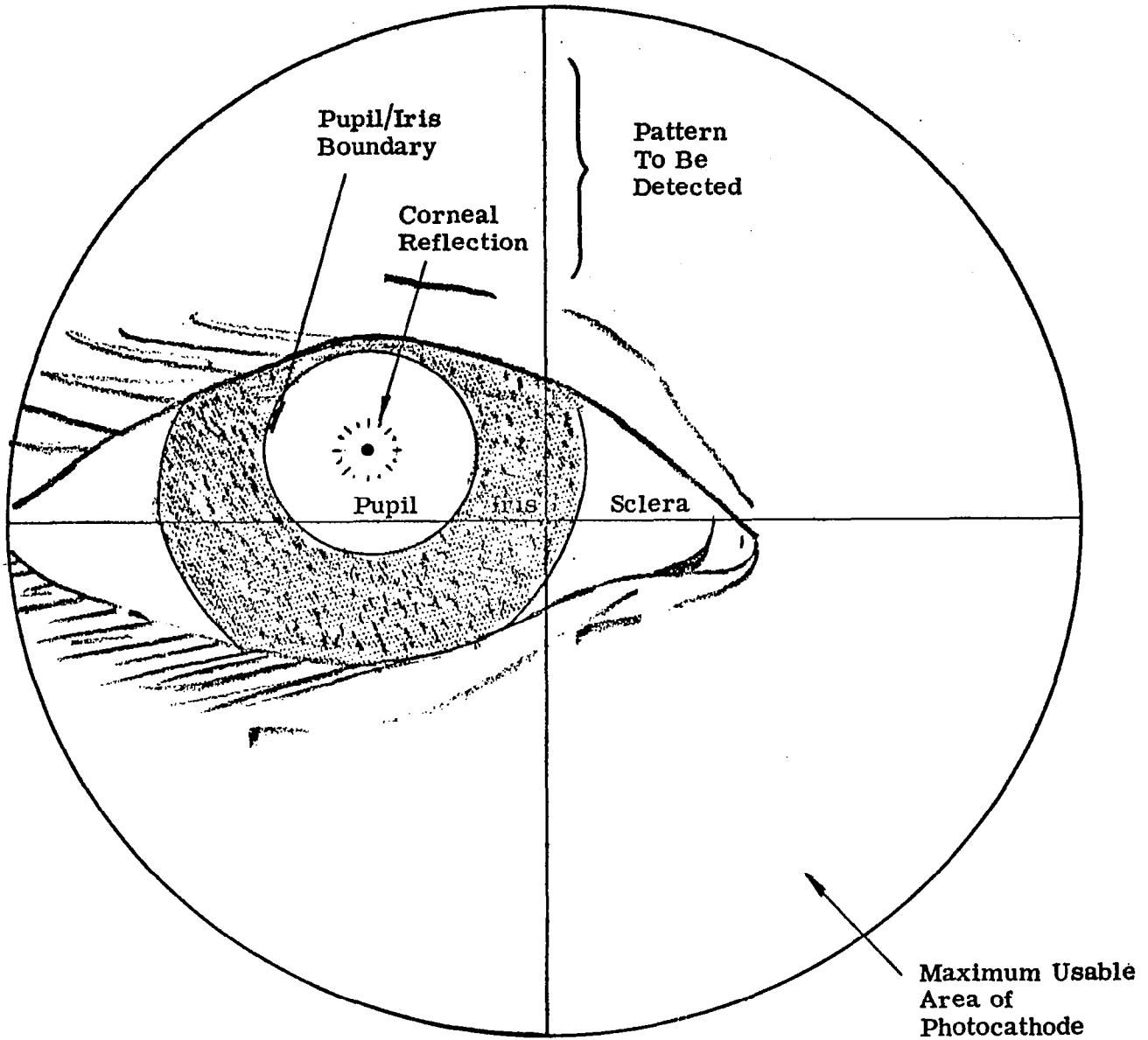

Figure 3.11 IMAGE OF EYE ON PHOTOCATHODE

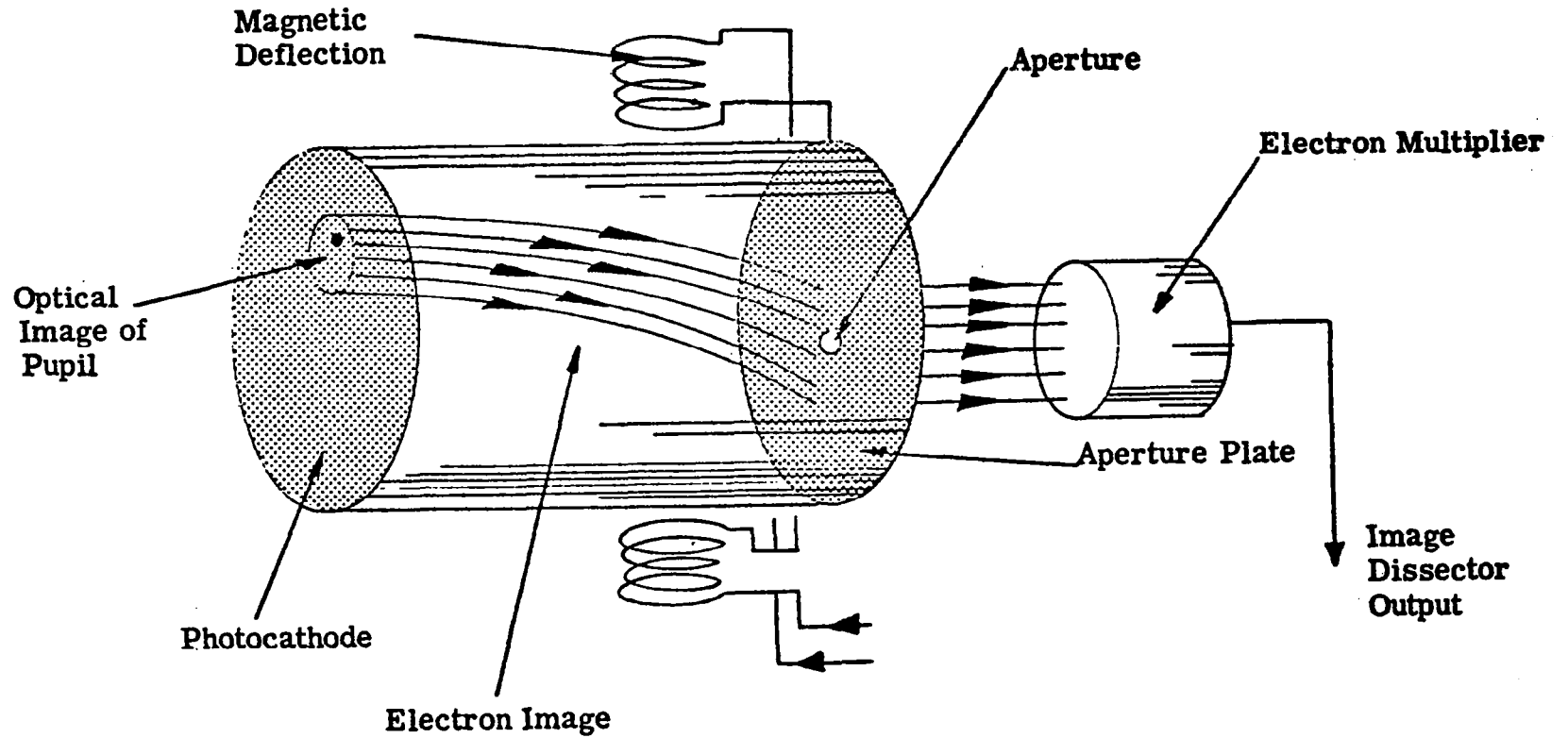
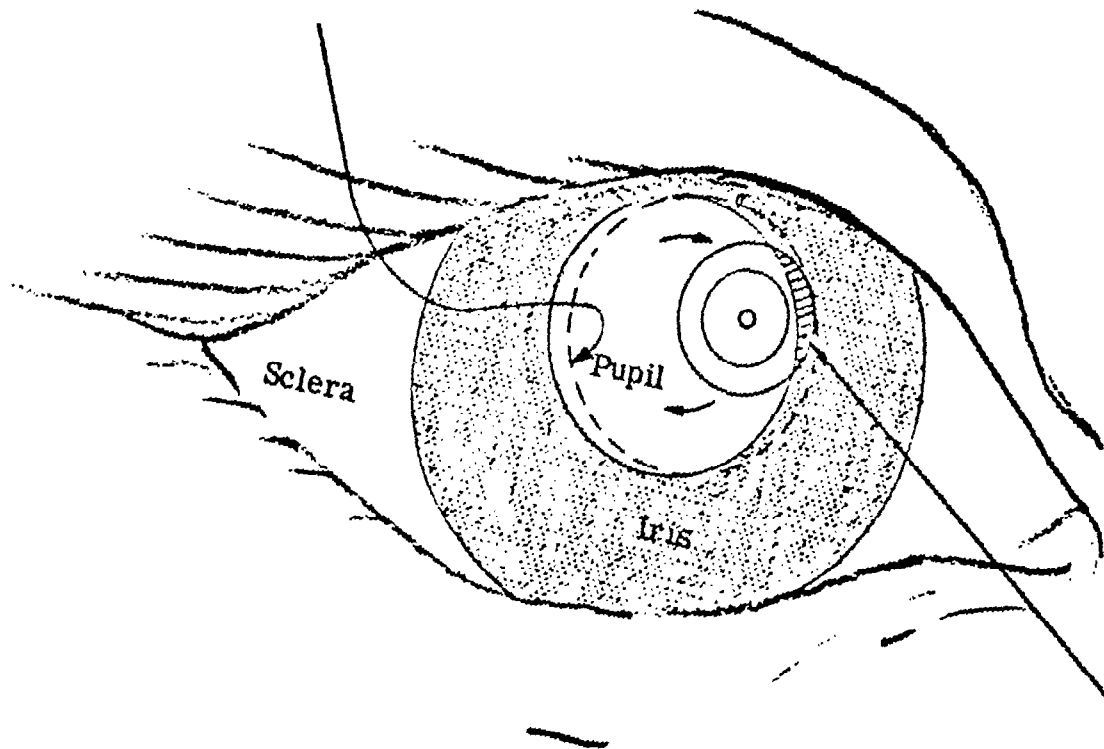

Figure 3. 12 IMAGE DISSECTOR



Segment of Bright
Iris Seen By
Rotating Aperture
Plate

Figure 3. 13 PUPIL SCAN OF APERTURE PATTERN

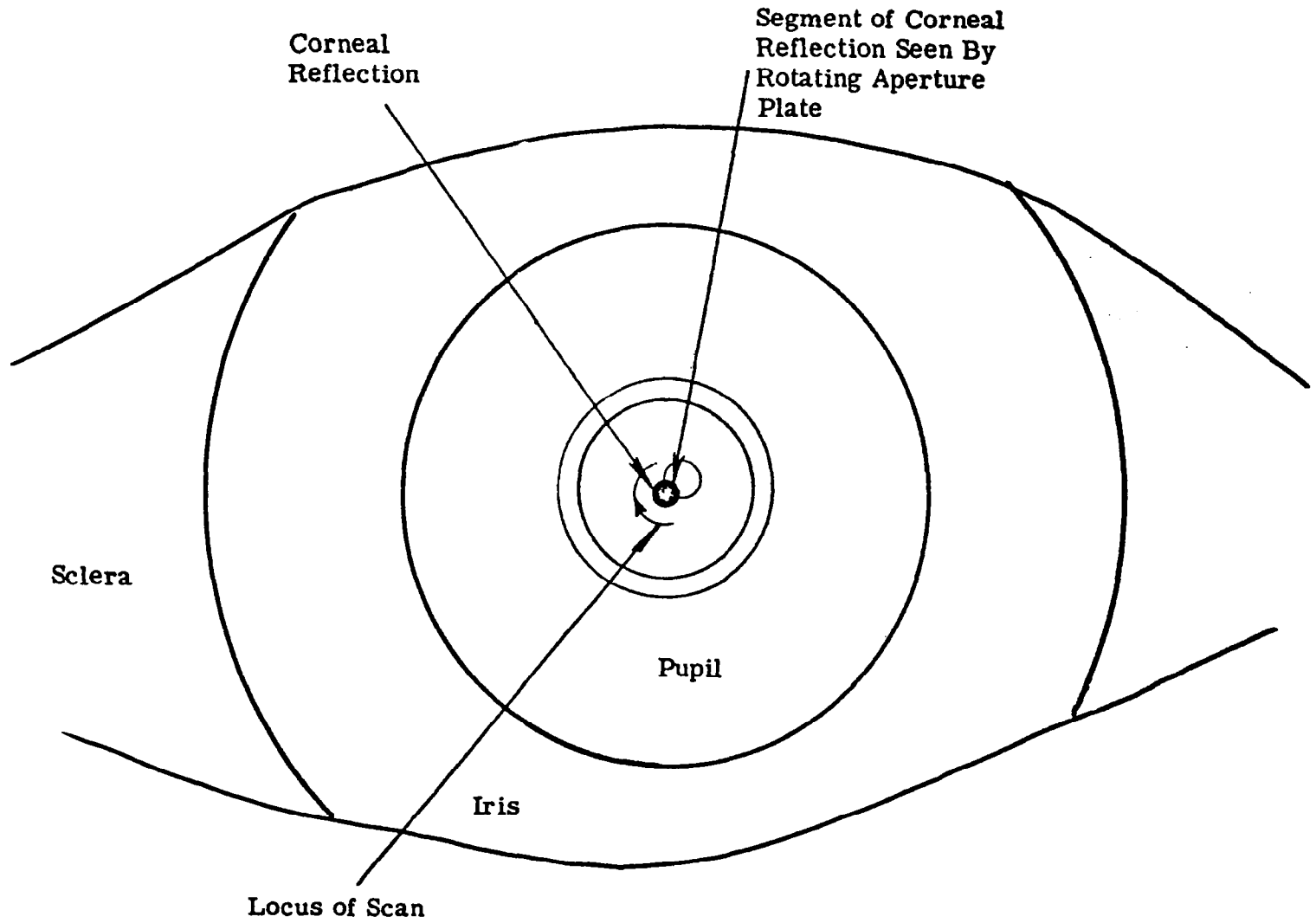

Figure 3.14 CORNEAL SPOT SCAN OF APERTURE PLATE

To accomplish both of the above tracking tasks simultaneously, time-division-multiplex is employed. The actual scan pattern is shown in Figure 3.15. Six samples of the pupil position and six samples of the spot position are made every cycle of the 120 cps rotating scan.

The resulting output of the ID tube will typically be as shown in Figure 3.16.* It may be noted that a 720 cps component is present because of a difference between the d-c level of the pupil 120 cps waveform and the d-c level of the spot 120 cps waveform. The magnitude of this difference in d-c level is proportional to the amplitude (radius) of the pupil tracking scan relative to the radius of the eye pupil, and is used to control this amplitude. Such control is necessary because of changes in the radius of the subject's pupil (e. g. , 2.25 mm to 5.0 mm).

The two time-division-multiplexed components of 120 cps in the output of the ID tube are separated by switching the output, between two channels, at a rate of 720 cps. Each channel is separately demodulated, and the in-phase and out-of-phase components are applied to the respective x and y deflection circuits.

There are three system control loops (see Figure 3.17):

1. pupil amplitude
2. pupil position
3. corneal tracking

*The corneal signal is chopped at a 14.4 kc rate to facilitate discrimination from the pupil/iris signal. The 14.4 kc modulation is not shown in Figure 3.16.

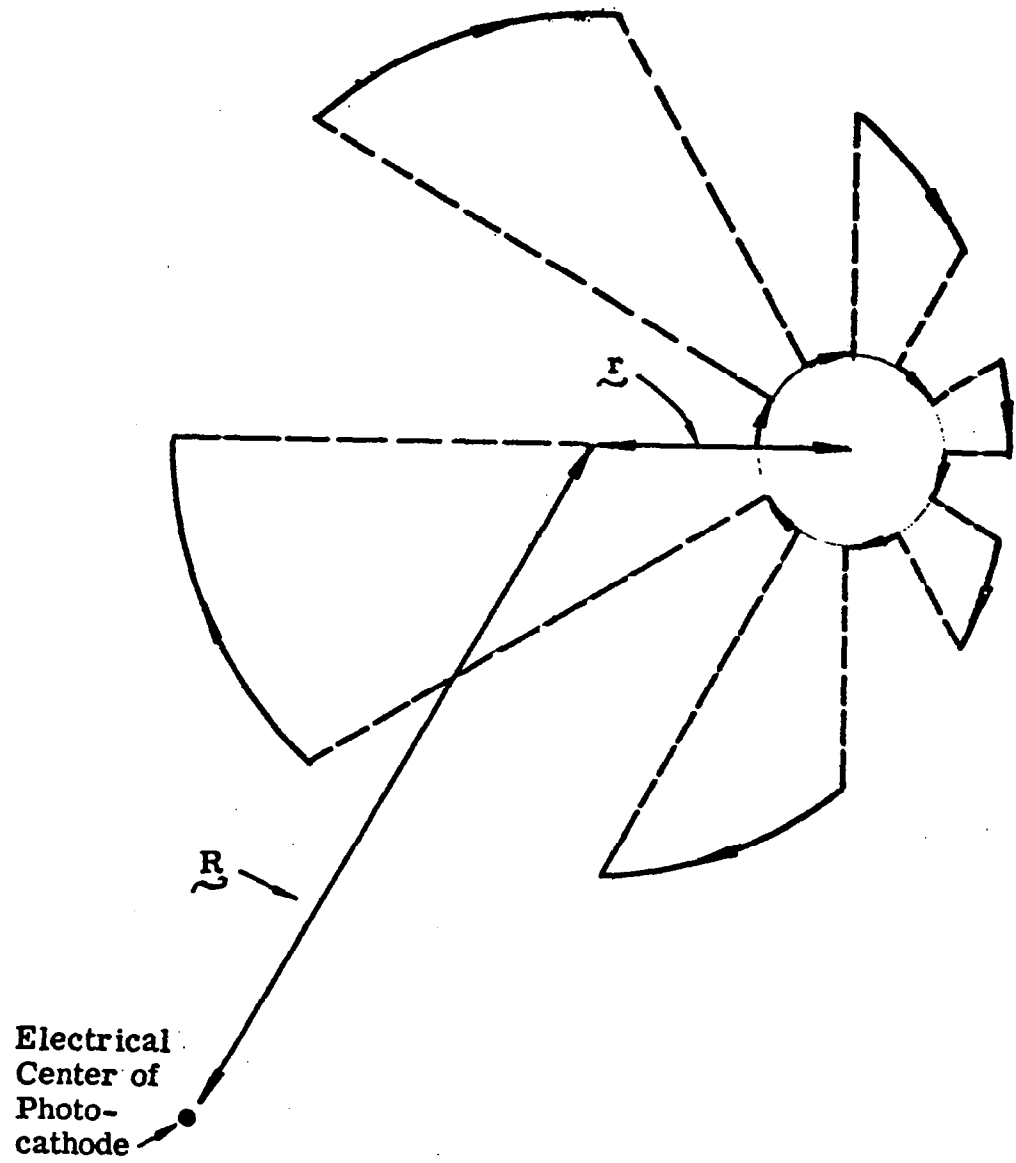
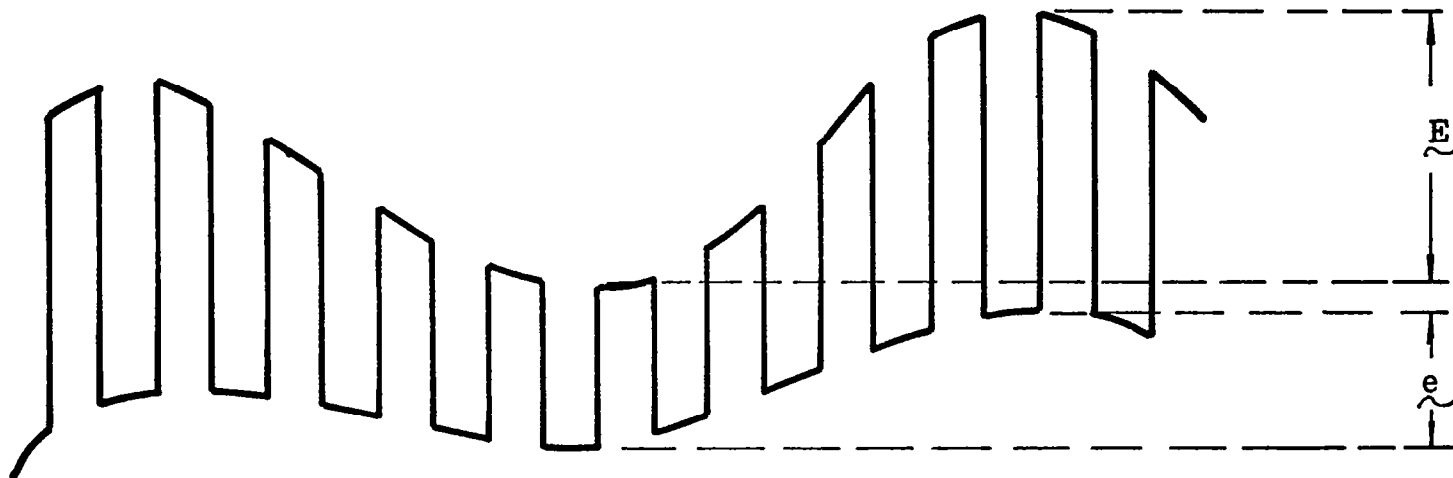

Figure 3.15 ROTATING, TIME-DIVISION-MULTIPLEXED CIRCULAR SCAN



\tilde{E} : error signal for pupil/iris channel

\tilde{e} : error signal for corneal reflection channel

Figure 3.16 ERROR SIGNAL INFORMATION IN IMAGE DISSECTOR OUTPUT SIGNAL
(14.4 kc Modulation Not Shown)

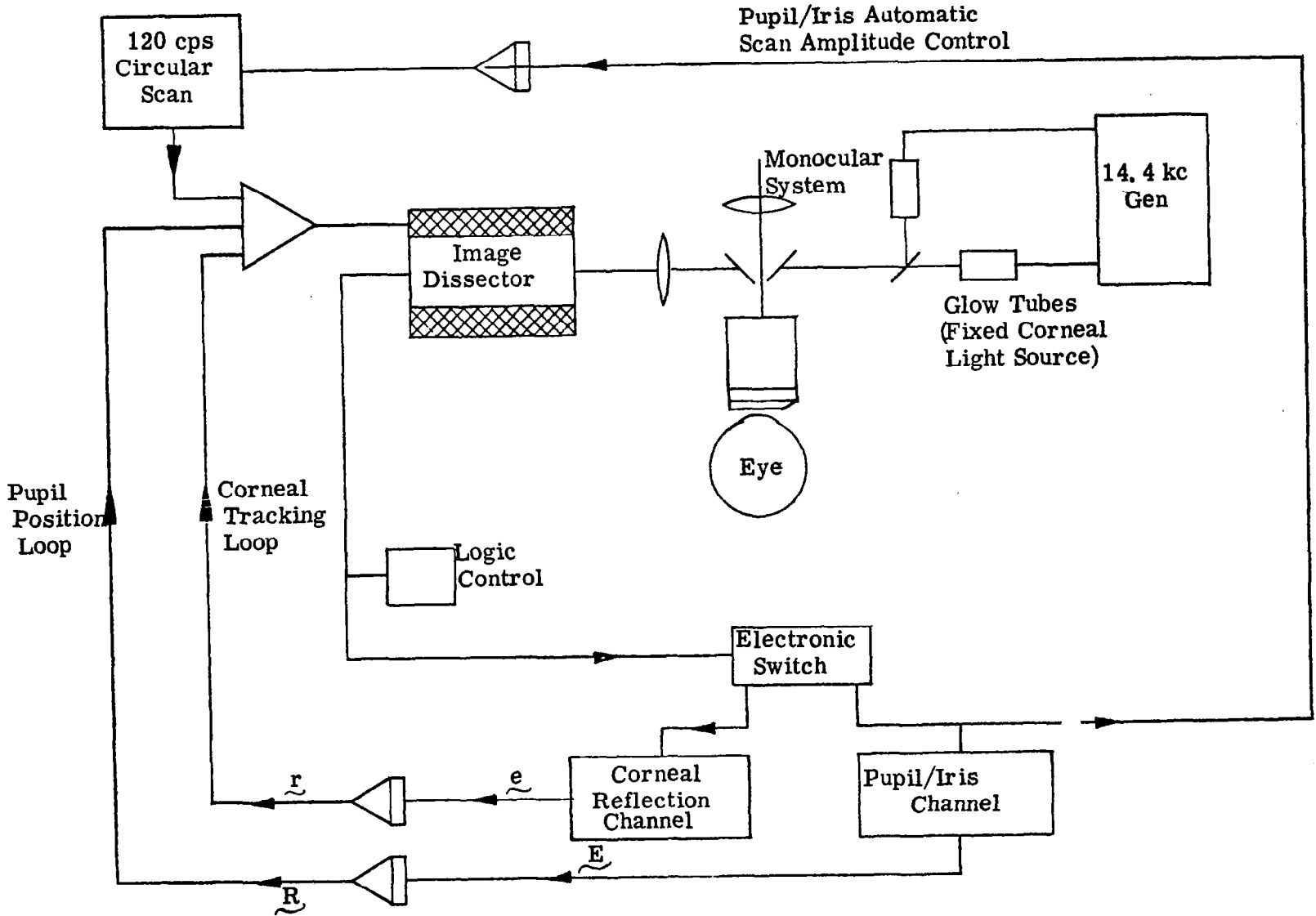

Figure 3.17 OCULOMETER BLOCK DIAGRAM

Since each loop contains a single integrator in the feedback path, loop response will be essentially that of a simple RC network.

The pupil position and corneal tracking loops have already been described.

In the pupil amplitude loop, the average d-c level existing in the pupil signal coming from the electronic switch is used to control the diameter of the circular scan. This d-c level is applied to an integrator, together with an adjustable d-c level of the opposite polarity, which serves as a reference. The control action causes the scan diameter to change so that the sum of the d-c level and the reference is zero. In other words, the loop controls the average brightness of the pupil/iris boundary as seen by the scanning aperture hole.

3.5 MECHANICAL DESIGN

3.5.1 Introduction

The optomechanical unit is shown in Figure 3.1.

The monocular part of the oculometer consists of an eyepiece and an objective lens mounted at the ends of the monocular tube. The eyepiece is fixed, but the objective lens is adjustable, to allow for focusing. The monocular tube contains an inner tube, behind the eyepiece, upon which are mounted the two beam splitters.

The corneal light illumination system is mounted vertically above the monocular tube. Light is projected from a glow modulator tube via the corneal illumination auxiliary lens, one of the beam splitters, and the main eyepiece, onto the eye.

The ID, together with its auxiliary lens and eyepiece, is mounted in the ID tube. The ID preamplifier assembly is fitted to the end of the ID tube.

This tube and the monocular tube are mounted on a base plate; the glow modulator assembly is mounted on a vertical bracket.

Polaroid material is placed over the face of the glow modulator tube, and on an adjustable analyzer plate in the ID tube. A quarter wave plate is cemented into the front of the eyepiece. The polarizer is adjusted for extinction of eyepiece reflections. The quarter wave plate is oriented to pass eye reflections.

The position of the corneal reflection relative to the center of the pupil is given by the output of the corneal integrators (\underline{r} , Figure 3.17). This position signal is approximately proportional to the direction of the eye. However, a small fraction of the pupil position signal (\underline{R}) must be added to account for a parallax, when the corneal reflection is not exactly formed in the plane of the pupil.

A simple computer circuit is used to compute eye direction. The output is

$$\lambda \underline{r} + \mu \underline{R} + \underline{k}$$

where λ represents an adjustable gain factor, μ is the parallax factor (generally $\mu < 0.05 \lambda$), and k is a variable dc offset for convenience in zeroing the output.

The computer output is filtered by a simple 20 cps cutoff RC network. Gates (activated by R and Q) are included in the computer to suppress the output during the acquisition modes.

3.5.2 Automatic Acquisition System

3.5.2.1 General Description

The purpose of the automatic acquisition system is to provide for immediate acquisition of the pupil/iris boundary and the corneal reflection. In the earlier oculometer breadboard design, eye tracking could take place only after the subject had moved his eye to a correct position with respect to the eyepiece. When the subject's eye was correctly positioned, the oculometer could be switched (manually) into the closed loop tracking mode, and the system would then "fall in" to track. Tracking would continue until the subject blinked or the image of his pupil moved off the photocathode. Thus, in practice, eye direction information was continuously available for only the relatively short period between blinks. This manual acquisition procedure was obviously undesirable and a rapid, automatic acquisition scheme was therefore implemented.

The general description of this automatic acquisition is as follows. At the initiation of oculometer operation, the double circular scan (described in Section 3.4.1) is suppressed and replaced by a coarse raster scan (15 lines, 15 frames/sec) of the eye image over the aperture hole in the ID

tube. This coarse scan continues until the black pupil area falls over the aperture hole, at which time it ceases. The next scan pattern is a multiplex, at 720 cps, of two scan patterns: (a) a circular scan intended to follow the pupil/iris boundary, and (b) a fine raster scan of the pupil area. This scan mode continues until the fine raster scan picks up the bright corneal reflection; at that point the fine scan is replaced by a small circular scan for tracking the corneal reflection. Thus the final scan pattern consists of the two multiplexed circular scans that follow the pupil/iris boundary and the corneal reflection as previously described in Section 3.4.1. This entire acquisition procedure is designed to take less than 150 milliseconds. The various scan patterns occurring during the acquisition sequence are illustrated in Figure 3.18.

The automatic acquisition system consists of three main parts:

- (1) The state sensors: these analyze the output of the ID to determine the conditions which must govern mode selection. The output of the state sensors consists of three signals:
 - LPT - "Loss of Pupil Track," ID output level indicates that it is scanning over the iris.
 - $\overline{\text{LPT}}$ - "No Loss of Pupil Track," ID output level indicates that it is scanning over the pupil/iris boundary.
 - LCT - "Loss of Corneal Track"
 - $\overline{\text{LCT}}$ - "No Loss of Corneal Track"
 - OV - "Overload," integrator output has reached its maximum level (\pm), corresponding to the scan being near the edge of the photocathode.
 - $\overline{\text{OV}}$ - "No Overload"

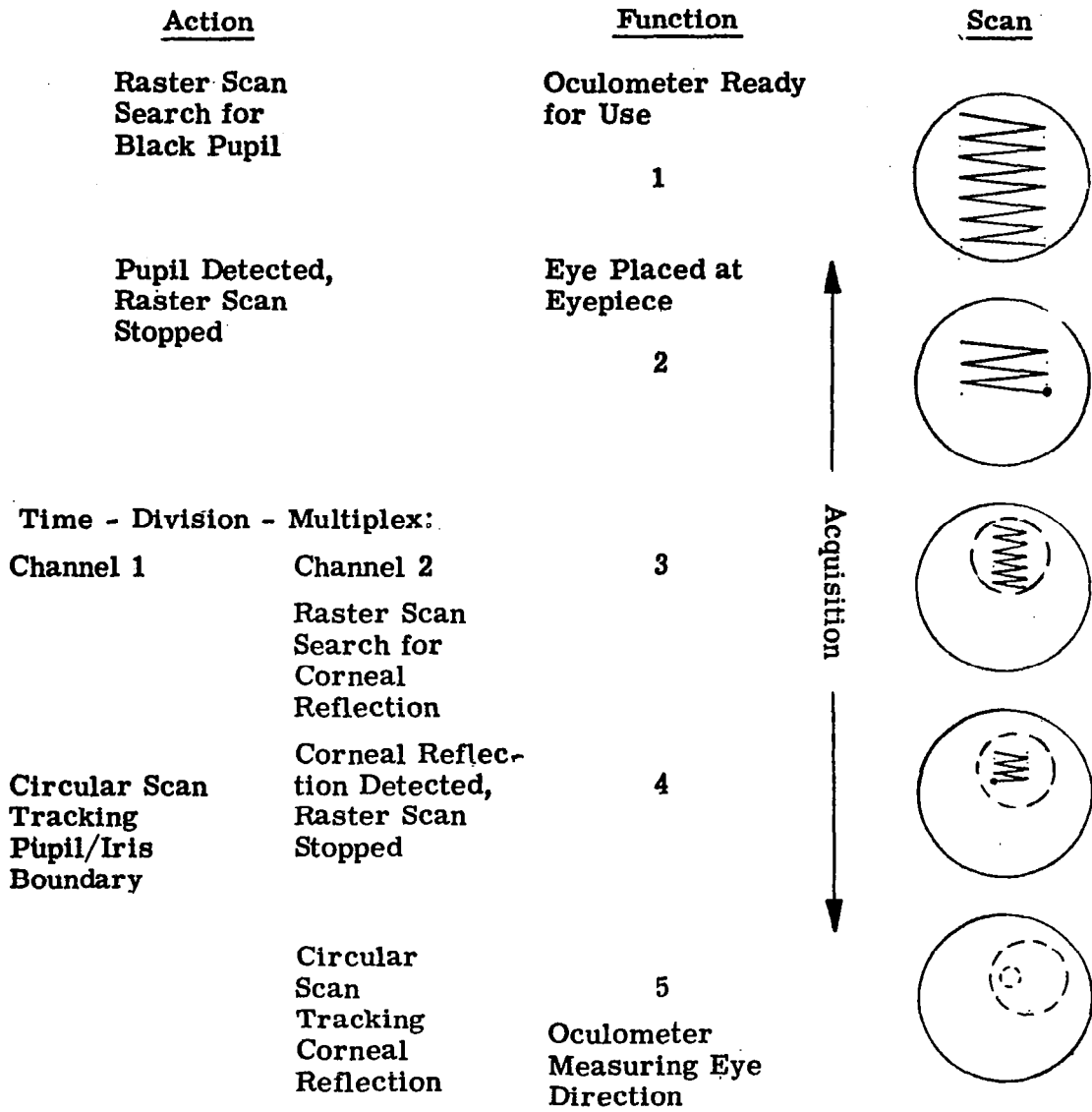

Figure 3.18 OCULOMETER ACQUISITION SEQUENCE

(2) The mode logic: the output of the state sensors is processed to generate mode command signals:

R - Execute pupil search raster scan

Q - Execute corneal search

(3) The scan circuitry: the signals R and Q are applied to various switches, gates, etc., interposed in the original oculometer tracking system. These switches, gates, etc., cause the appropriate scan pattern to be generated according to the commands of R and Q.

3.5.2.2 State Sensors

The acquisition system requires sensors to determine (a) when the coarse raster scan crosses into the pupil, and (b) when the fine raster scan crosses into the corneal reflection spot. These sensors are described below.

The first unit (called the LPT generator), which senses the presence or absence of the pupil, is shown schematically in Figure 3.19. During pupil search, there is a coarse raster scan, with level sensor P1 sensing the amplified output of the ID tube. During the coarse scan, the multiplex switch, which opens and closes at a 720 cps rate, is bypassed by the shunt switch. The shunt switch is activated (by the R pulse) so that it is closed only during pupil search. When the tube output falls below a prescribed value, the P1 output goes from high (+15 volts) to low (zero volts), indicating the presence of the pupil.

The output of the LPT sensor is the same as the output of the level sensor P1 when the override switch is transmitting. When the override switch is nontransmitting, the LPT output is zero volts. The override switch can be activated (made nontransmitting) by either level sensor P2 or the delay

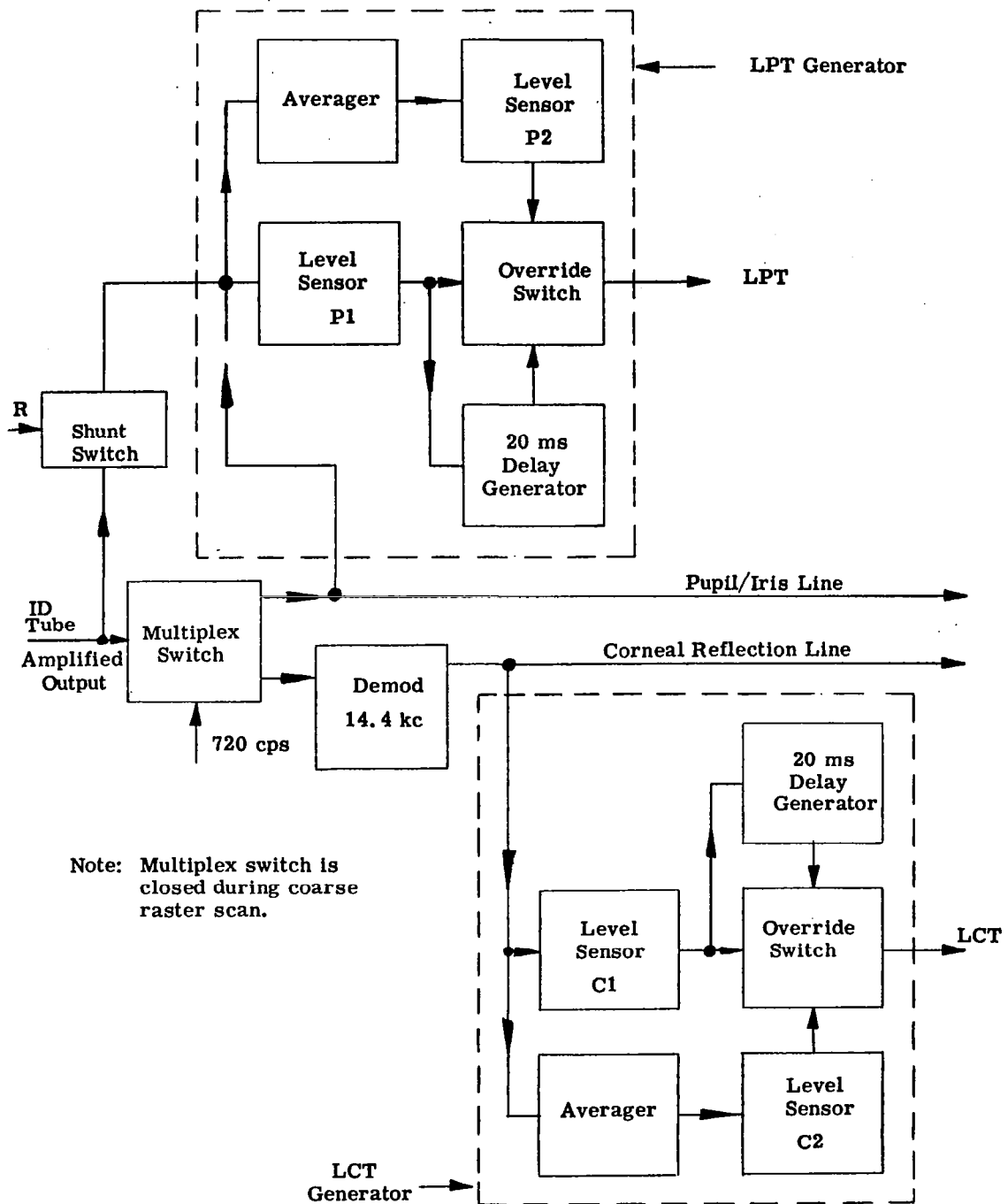

Figure 3.19 BLOCK DIAGRAM OF LCT AND LPT GENERATORS

generator. The delay generator activates the override switch for 20 milliseconds after the level sensor P1 output goes from high to low; thus the LPT sensor stays in the pupil acquisition mode for at least 20 ms after the scan crosses the pupil. The input to level sensor P2 is the ID tube output averaged over approximately a 20 millisecond time period by means of a low pass filter. Level sensor P2 activates the override switch as long as the averager output stays below a certain prescribed value. Thus the LPT sensor remains in the pupil acquisition state as long as the average ID tube output stays below that prescribed value. In this way the LPT sensor will not indicate loss of track until a sustained increase in signal from the ID occurs.

In summary, the LPT sensor is designed to go into a pupil acquisition state at the instant the pupil is crossed by the raster scan; it is designed to stay in that state as long as the circular scan is closely following the pupil/iris boundary. It will go into the pupil search state only after 20 milliseconds of continuous indication of loss of the pupil.

The second unit, called the LCT generator, senses the presence or absence of the corneal reflection; it also consists of five blocks, as shown schematically in Figure 3.19. The input to the generator is the multiplexed, demodulated ID tube output. Its operation is identical to that of the LPT generator; with one important exception: namely, the presence of the corneal reflection is accompanied by an increase in the ID tube output. Thus level sensor C1 indicates corneal reflection presence when its input goes high. Similarly, level sensor C2 activates the override switch as long as the averager output is above a prescribed value. In all other respects, the LCT operates like the LPT generator. The corneal acquisition state is indicated immediately

when the corneal reflection is crossed, and that state is maintained as long as the small circular scan closely follows the corneal reflection spot. The corneal search state is indicated only after 20 milliseconds of sustained indication of loss of the corneal reflection.

A third state sensor is needed for proper operation of the automatic acquisition system. There must be a signal to indicate when the coarse raster scan falls off the effective photocathode area. This signal, called the OV signal, is obtained from circuitry that monitors the outputs of the pupil/iris loop integrators.

3.5.2.3 Mode Logic

The outputs of the LCT, LPT, and OV generators are used to determine what type of scan of the photocathode should be activated. As discussed earlier, there are three scan modes of interest:

1. A single, coarse raster scan, which occurs in the pupil search, or R, mode.
2. A pupil/iris boundary circular scan time-division-multiplexed with a fine raster scan, which occurs in the corneal search, or Q, mode.
3. A pupil circular scan time-division-multiplexed with a corneal circular scan, which occurs in the track mode.

The generation of the R level is accomplished by use of an OR gate, while the Q level is generated by an AND gate, as shown in Figure 3.20. The tracking mode is, by definition, the absence of the R and Q signals.

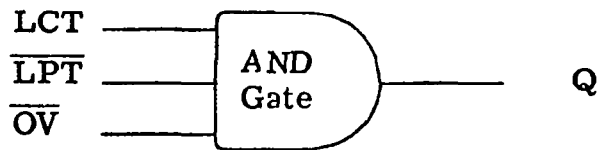
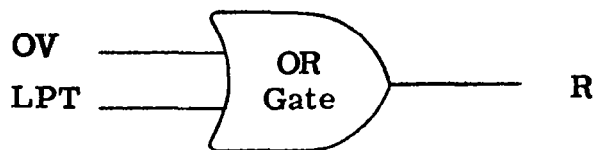

Legend:

- OV = Scan off photocathode
- LPT = Loss of pupil track
- LCT = Loss of corneal track
- R = Pupil Search State
- Q = Corneal Search State

Figure 3.20 MODE LOGIC DIAGRAM

3.5.2.4 Automatic Acquisition Scan Circuitry

Various electronic switches, gates, etc., were added to the tracking loop circuitry of the earlier (Phase I) oculometer electronics in order to implement the automatic acquisition scheme. These gates, switches, etc., controlled by R and Q logic levels, command the generation of the acquisition raster scans while simultaneously inhibiting the circular scans that are implemented during actual track.

A block diagram of the automatic acquisition circuitry is shown in Figure 3.21. The diagram represents the circuitry used in the earlier oculometer breadboard, with the addition of the following items:

- a. The four pulse generators, FFV1, FFV2, FFH1, and FFH2.
- b. The four overload sensors, OVH, OVV, OWH, and OWV.
- c. The five gates, GO1, GO2, GO3, GO4, and GO5.

The four pulse generators, together with their associated integrators, generate the raster scans. The outputs of the pulse generators are applied to the integrators shown in the diagram. If a constant signal is fed into the integrator, the output will be a ramp which can, in turn, deflect the electron image in the ID tube at a constant rate. Appropriately timed ramps are fed into both the horizontal and vertical ID deflection channels to produce a raster scan. In this raster system, the output of each pulse generator changes polarity when the deflection position reaches an edge of the photocathode. The overload sensors monitor the outputs of the integrators. When an integrator output exceeds a prescribed absolute value (either positive or negative), an appropriate logic signal is fed back to the pulse generator, causing it to change the polarity of its output.

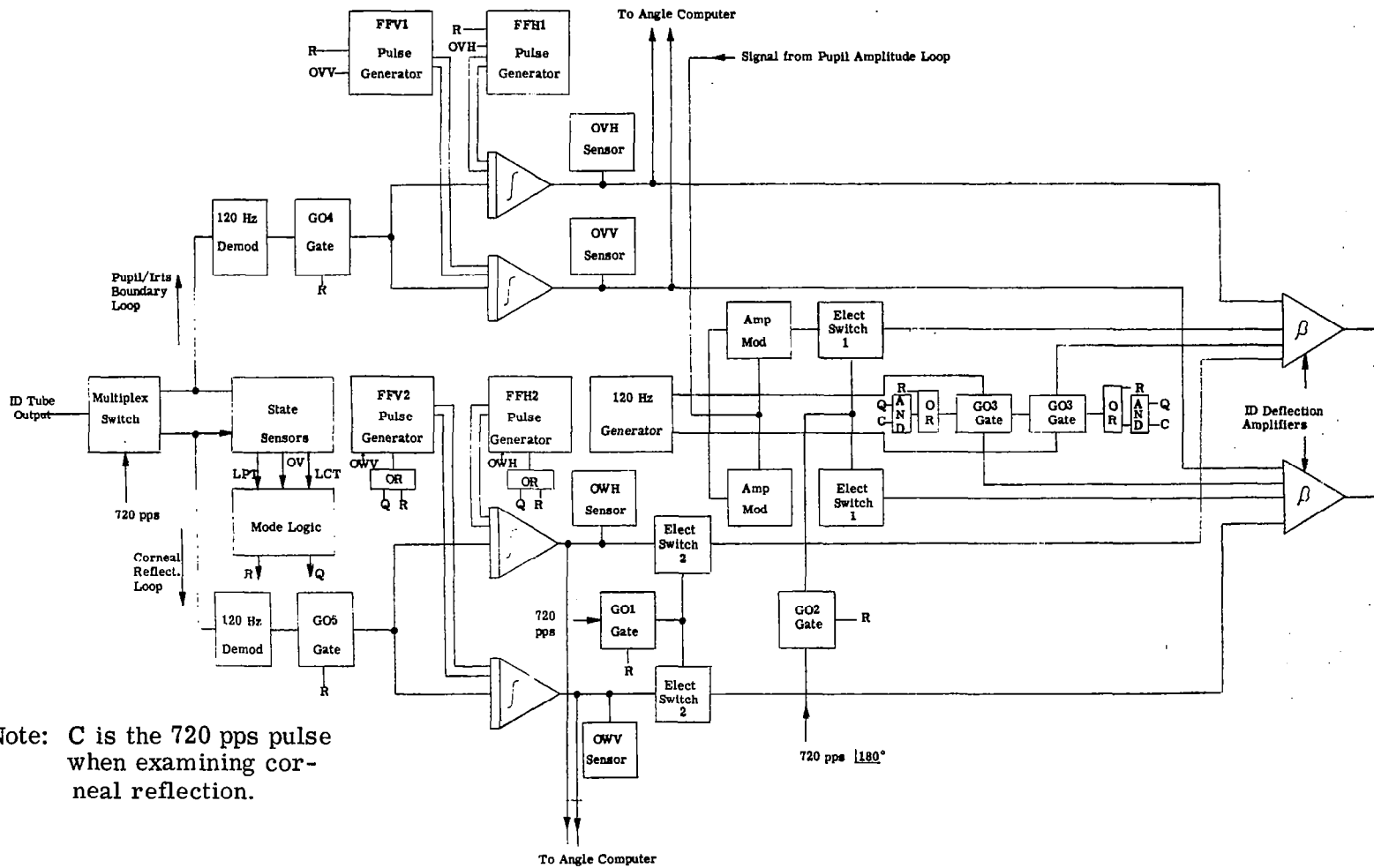

Figure 3.21 AUTOMATIC ACQUISITION SYSTEM BLOCK DIAGRAM

The FFH1 and FFV1 pulse generators activate the coarse raster for pupil search. They are commanded by an R signal (pupil search mode), as shown in the diagram. FFH1 creates the horizontal deflection; the polarity of its output is controlled by OVH. FFV1 creates the vertical deflection; the polarity of its output is controlled by OVV.

The FFH2 and FFV2 pulse generators generate the fine raster. They are activated by both the R and Q logic levels. However, during the R mode (pupil search), the outputs of the corneal loop integrators are prevented by electronic switch 2 from reaching the deflection coils. The reason why the corneal raster is activated during pupil search (R) is that it prevents the corneal integrators from drifting into a saturated overload condition.

The action of the FFH and FFV units, in detail, is defined by the following logical constraints: FFH1 is a unit having two outputs, i. e., FFH1(a) and FFH1(b). Both outputs may be in either the "ON" or the "OFF" state. The condition of the two outputs is controlled by two other logic levels, R and M, according to the following rules:

FFH1(a)	ON	}	R and M
FFH1(b)	OFF		
FFH1(a)	OFF	}	R and \bar{M}
FFH1(b)	ON		
FFH1(a)	OFF	}	\bar{R}
FFH1(b)	OFF		

Logic level R has already been described. Logic level M is defined as follows:

M switches ON, and stays ON, with the occurrence of the logic signal

$$\left\{ +OVH \text{ or } \left[\frac{dR}{dt} \right] \right\}$$

where $\left[\frac{dR}{dt} \right]$ means a positive value of $\frac{dR}{dt}$.

M switches OFF, and stays OFF, with the occurrence of the logic level

$$[-OVH]$$

When the R pulse comes on, $\frac{dR}{dt}$ will have a momentary positive value. This will cause the M pulse to go ON and stay ON. This, in turn, will cause the FFH1(a) pulse to go ON, with FFH1(b) OFF. Output FFH1(a) is applied to the integrator in such a polarity as to cause the integrator output to move toward the -OVH overload threshold. As soon as this threshold is reached, the M level will change to \bar{M} , and this in turn will cause the FFH1(a) pulse to go OFF and the FFH1(b) pulse to go ON. The FFH1(b) pulse is applied to the integrator in such a way as to cause its output to change uniformly from the -OVH threshold level toward the +OVH threshold level. When this latter level is reached, the \bar{M} pulse is switched back to M, and stays at M. As previously described, this causes the integrator output to move, once again, toward the -OVH threshold level.

The logic for FFV1 is exactly the same, utilizing the +OVV and -OVV pulses in place of +OVH and -OVH.

The FFH2 and FFV2 units are exactly the same, except that R in FFH1 and FFV1 is replaced by (R or Q), and OVV/OVH is replaced by OWV/OWH.

Gates GO1 through GO5 ensure that the proper sequence of scans is accomplished. Gate GO1 serves to make electronic switch 2 nontransmitting during the R mode. Gate GO2 is identical to GO1, except that it makes electronic switch 1 nontransmitting during the R mode. During the corneal search (Q) and normal track modes, GO1 and GO2 pass the 720 pps signal, which causes the respective switches to be, alternately, transmitting and nontransmitting.

The two GO3 gates serve to prevent the small circular scan drive from reaching the deflection coils during the raster scans.

Gate GO4 prevents the ID tube output from reaching the pupil/iris loop integrators during the coarse raster scan and thereby possibly distorting the scan.

SECTION 4 EXPERIMENTAL RESULTS

4.1 OCULOMETER CHARACTERISTICS

4.1.1 Error Signal

The pupil/iris boundary of the eye is tracked by means of a circular scan which is nominally concentric with the pupil. Any error in the position of the scan relative to the pupil results in a 120 cps modulation of the ID output. This is demodulated to yield a d-c error signal proportional to the scan position error.

In order to test this error signal generation process, a sawtooth signal, $V(t)$, was introduced into the deflection amplifier with the horizontal tracking loops opened, and the pupil of the eye was located approximately concentrically with the nominal position of the circular scan (see Figure 4.1).

The effect of signal $V(t)$ was to move the locus of the 120 cps circular scan back and forth across the pupil of the eye. The output of the horizontal 120 cps demodulator was recorded (see Figure 4.2). It can be seen that a linear scan position error signal is produced over a satisfactory dynamic range. The high frequency component superimposed on the trace (in Figure 4.2) is the result of the demodulation of the 120 cps: it is filtered out by the action of the scan position integrator, which follows the 120 cps demodulator in the control loop.

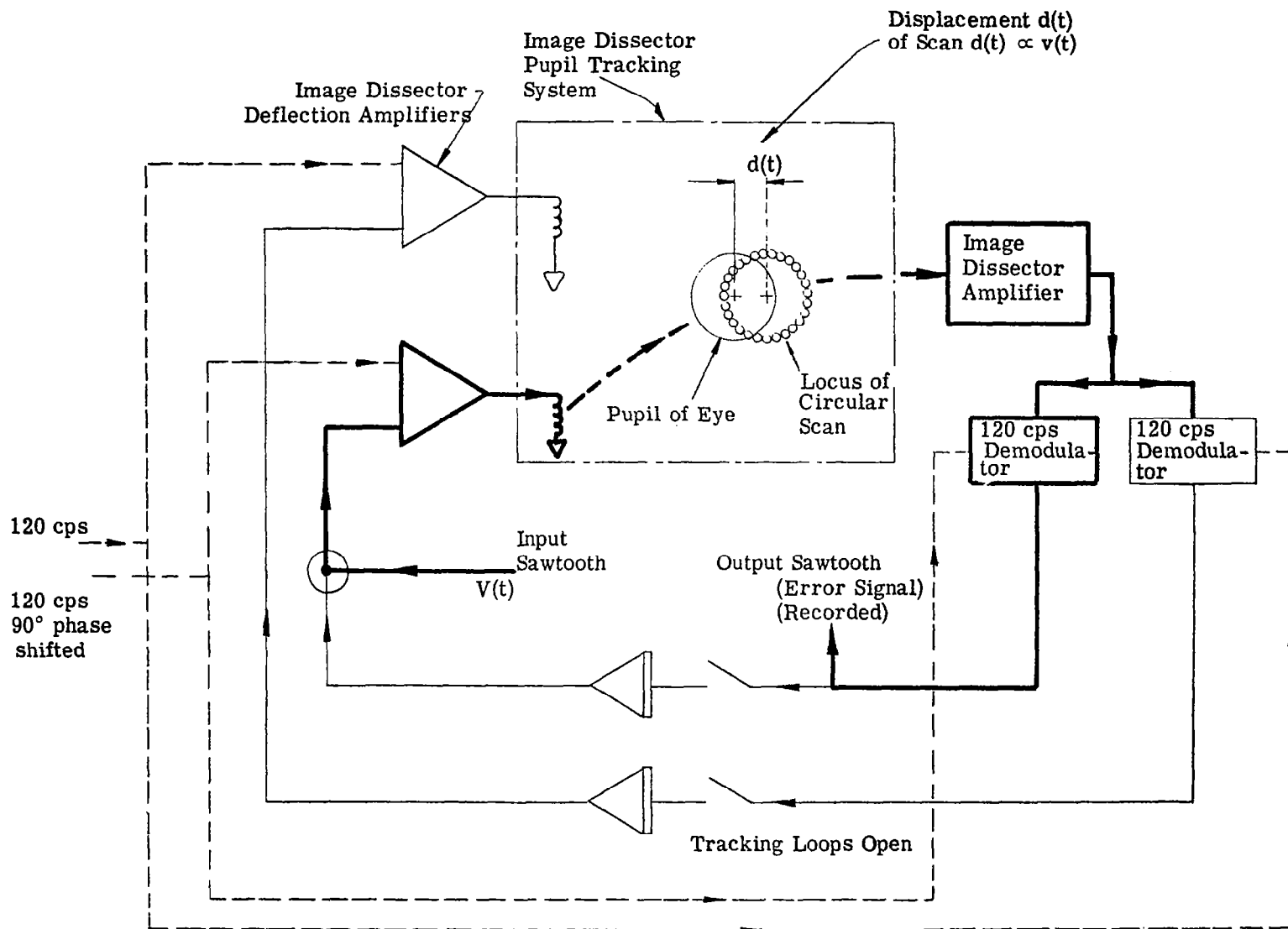

Figure 4. 1 SCHEMATIC OF ERROR SIGNAL TEST

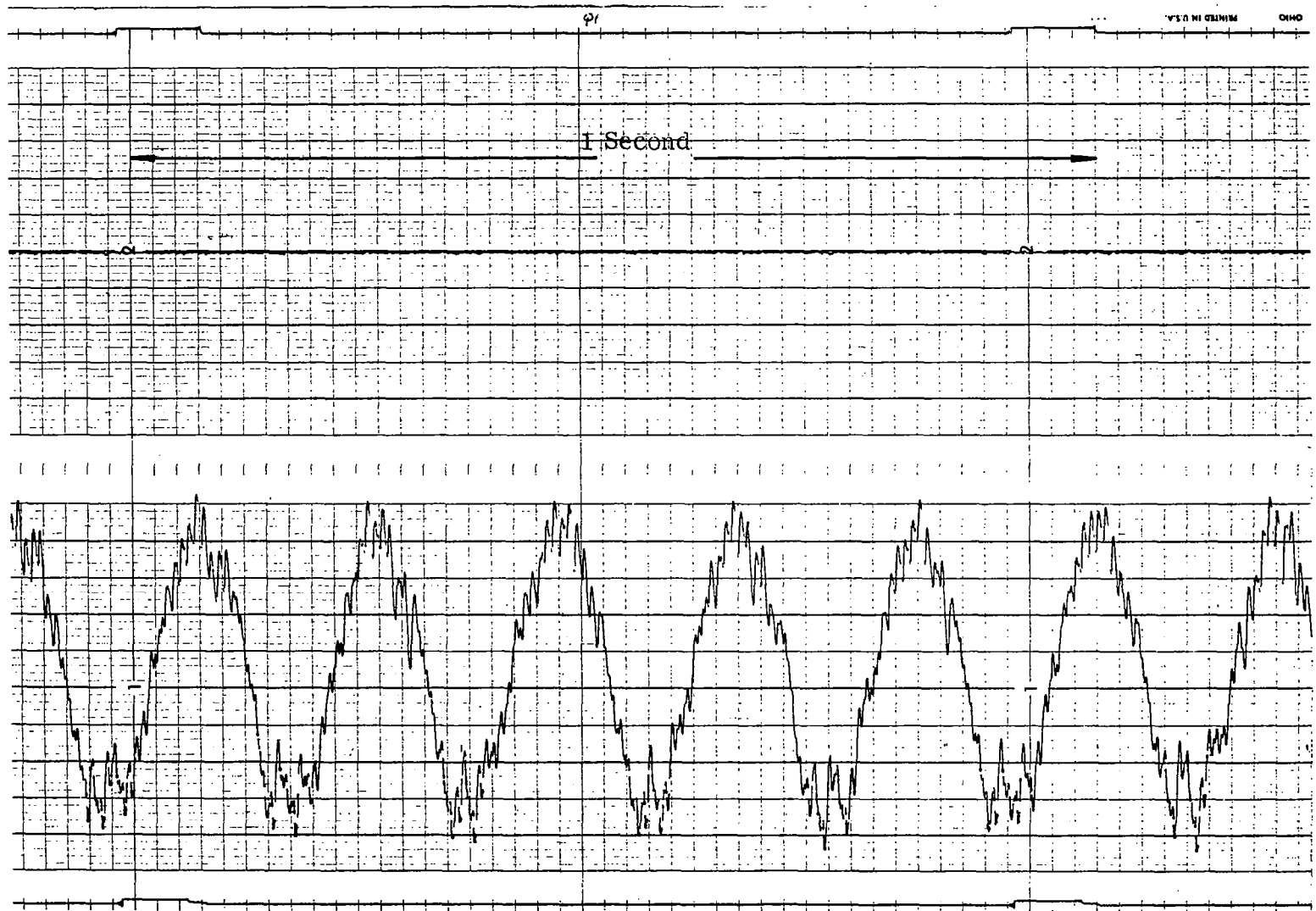

Figure 4.2 SCAN ERROR SIGNAL RECORDED

(Scan deviation approximately 1.8 mm peak-to-peak at the eye. Pupil diameter approximately 5 mm.)

4. 1. 2 Tracking Dynamics

A test was made of the dynamic tracking capability of the oculometer, independently of the response of the eye. The pupil tracking loop was tested as illustrated in Figure 4. 3. A step input, $V(t)$, was added into the horizontal deflection amplifier of the ID scan system. This caused an almost instantaneous displacement, $d(t)$, of the circular scan relative to the pupil (the response time of the scan deflection system is approximately 30 microseconds). As a result of this displacement, an error signal was produced by the horizontal 120 cps demodulator. Because the tracking loop was closed for this test, this error signal was applied to the (horizontal) scan position integrator. The integrated value of the error was then added into the horizontal deflection amplifier. The result of this action was that an equal and opposite step displacement was generated by the scan position integrator to cancel the effect of injected step $V(t)$. With no scan position error there was no error signal, and the integrator value remained constant in its new condition.

The integrator response to the step input added into the horizontal deflection amplifier is shown in Figure 4. 4. The magnitude of the displacement corresponds to about 2. 4 mm at the eye. This test was done with a human eye in track. The motion of the trace between the steps is due to the inevitable eye and head motion.

Figure 4. 4 illustrates the good dynamic characteristics of the pupil tracking system. The step response time is of the order of 1/15 second, with no observable overshoot. A slight transient cross coupling between the x and y axes may be noted.

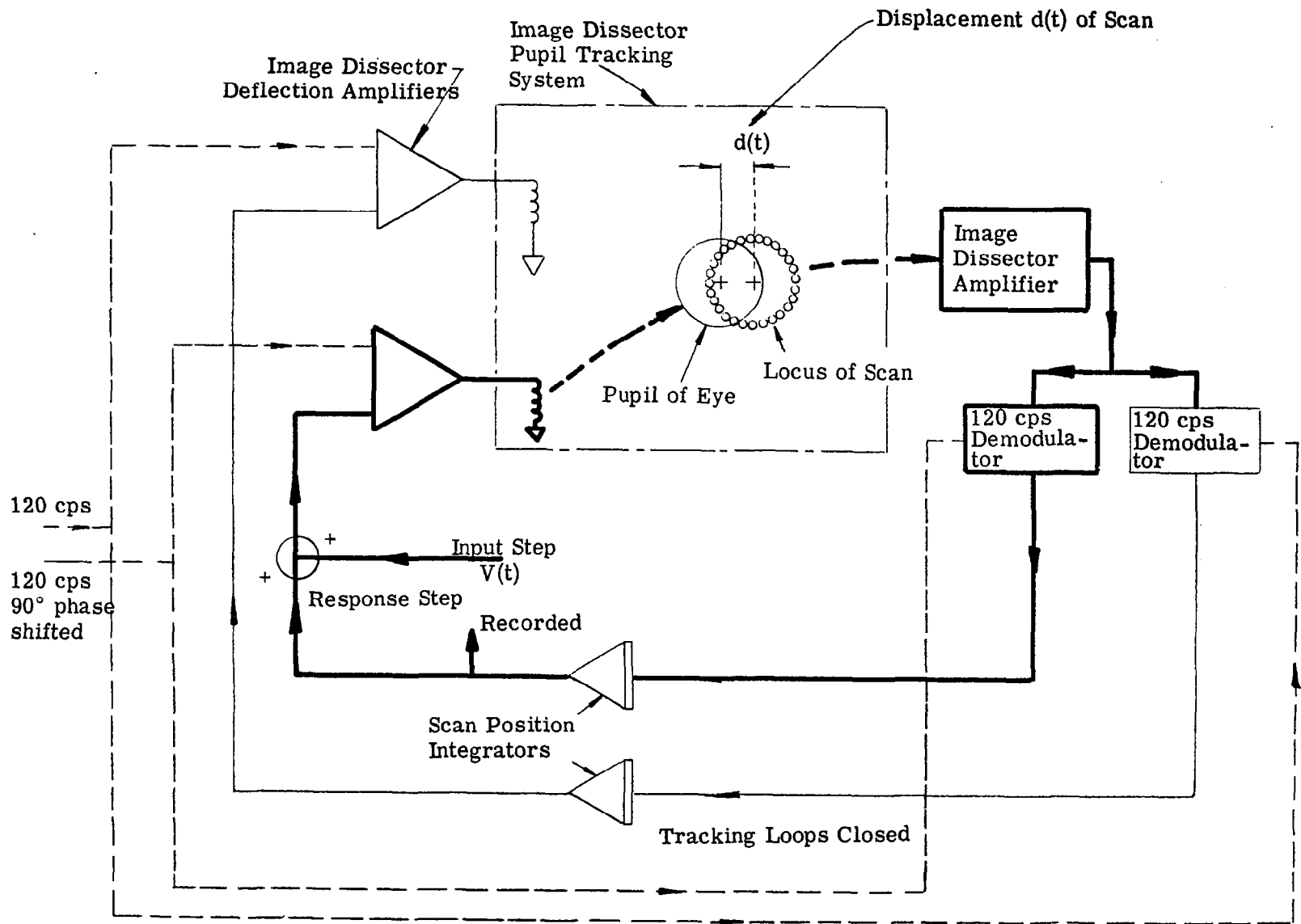

Figure 4.3 SCHEMATIC OF DYNAMIC TEST OF OCULOMETER TRACKING LOOP

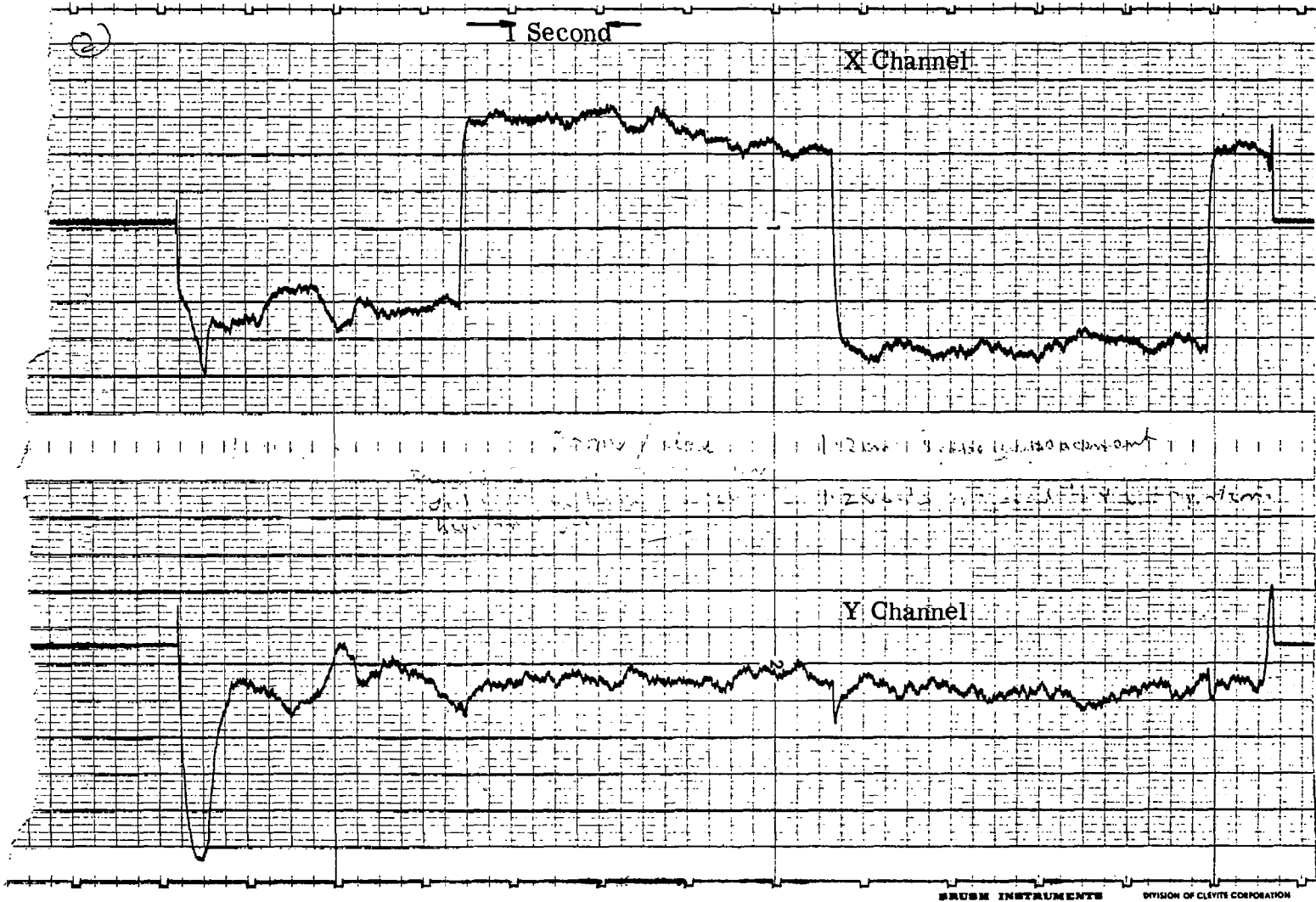

Figure 4.4 CLOSED LOOP RESPONSE OF PUPIL POSITION LOOP TO VIRTUAL
2.4 mm STEP DISPLACEMENT AT THE EYE
(Pupil integrator output at 50 mv/line)

A similar test was undertaken with the corneal tracking loops. For this test, the step input was applied, as before, to the horizontal deflection amplifier, but in this case the pupil tracking loops were open (in the reset mode) and the corneal loop was closed while tracking the corneal reflection in the eye. The output of the horizontal corneal integrator was recorded (Figure 4.5) for an equivalent step displacement at the eye of 0.6 mm.

The response time of this loop, as recorded, is about 1/20 second, with no detectable overshoot. There is some transient crosstalk between the two channels. As in the similar pupil loop test, the motion of the trace between steps is due to eye and head motion.

The response time of each loop is determined, in part, by the corresponding loop gain setting. For the test recordings shown in Figures 4.4 and 4.5, the gains were set high enough to achieve a satisfactory response time, without incurring transient overshoots or excessive noise. As the gain is turned to the maximum control setting, the noise level increases. At the gain setting chosen, the noise level was essentially independent of the gain. In other words, the primary noise mechanism was not an inherent part of the tracking loop. The noise characteristics of the traces are discussed further in the next section.

4.1.3 Loop Noise

Examination of the traces shown in Figures 4.4 and 4.5 reveals a number of noise components superimposed over the nominal step wave responses. As noted earlier, part of this noise is due to eye and head motion.

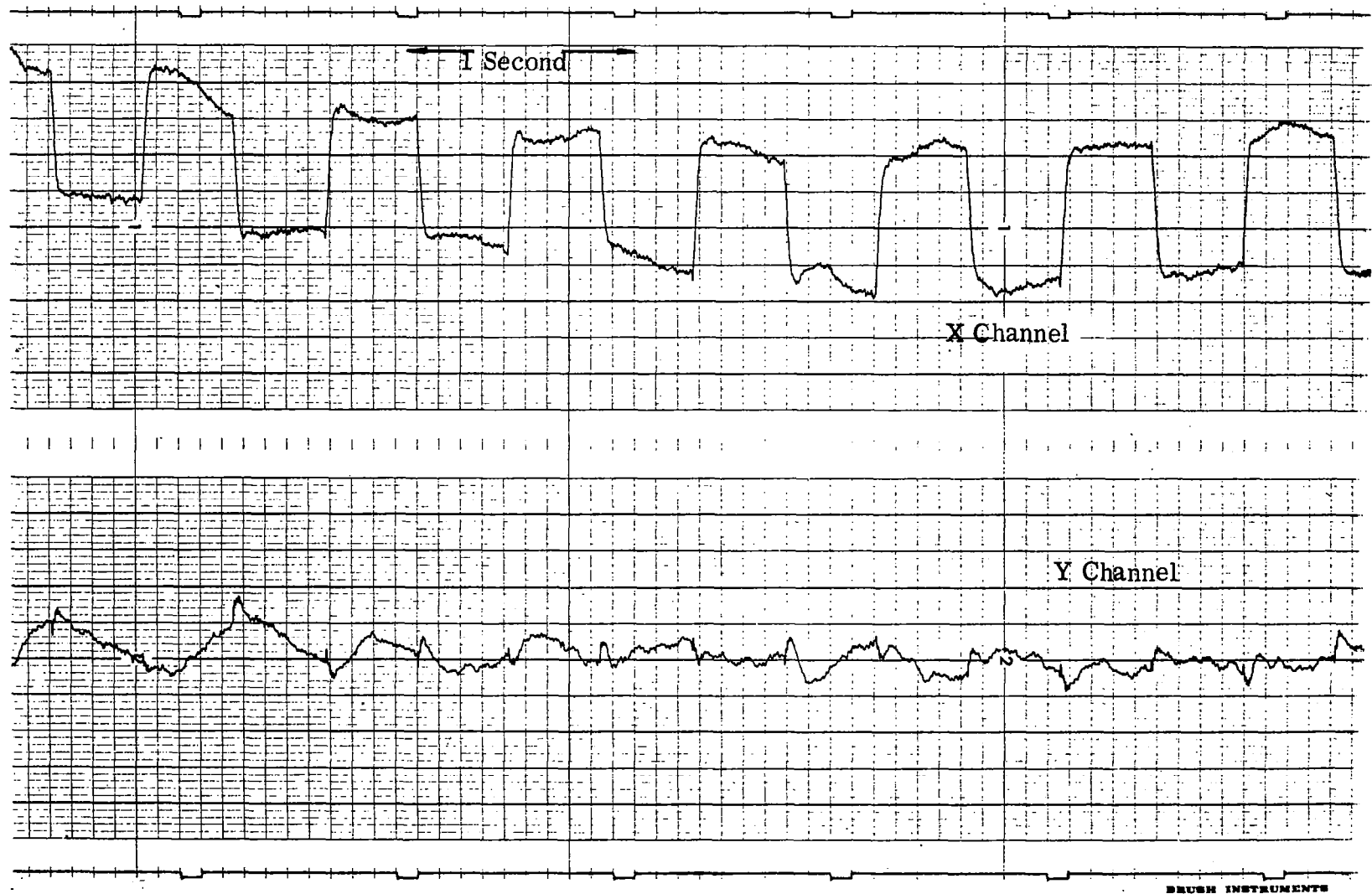

Figure 4.5 CLOSED LOOP RESPONSE OF CORNEAL POSITION LOOP TO VIRTUAL 0.6 mm STEP DISPLACEMENT AT THE EYE
(Corneal integrator output at 100 mv/line)

In order to show the various components of noise more closely, a trace was run of the pupil loop integrator output while tracking a stationary artificial pupil (see Figure 4. 6). Figure 4. 7 shows the pupil integrator output with the oculometer in the reset mode, with all loops open. As may be seen, a spurious 60 cps component exists in the integrator outputs. This single frequency component does not represent an absolute limitation on the performance of the oculometer, since it can obviously be removed, either by filtering or by being eliminated at its source (probably a ground loop problem).

Figure 4. 8 shows an estimate of the noise remaining after the 60 cps component is removed while tracking an artificial pupil.

As indicated by these recordings, the major true noise components over a 0-20 cps bandwidth have an RMS value of approximately 0. 8 degree (assuming a conversion factor of 20 degrees/mm). Over a 1. 5 cps bandwidth, the RMS noise would be 0. 2 degree.

Similar tests were made of the corneal tracking loop. A small lens was used to simulate the cornea of the eye. The oculometer tracked a stationary reflection in this lens. A recording of the integrator outputs is shown in Figure 4. 9 at 20 mv/line and in Figure 4. 10 at 100 mv/line. A trace was also run of corneal tracking of the human eye (Figure 4. 11, at 100 mv/line). This trace shows head and eye motion in addition to instrument noise. It is clear from Figures 4. 9 and 4. 10 that the instrument noise level is somewhat lower when tracking the corneal reflection in the human eye than with the artificial cornea (lens). (In the corneal tracking traces shown in Figures 4. 9, 4. 10, and 4. 11, the pupil position loop was open, in the reset mode. The oculometer was then tracking the absolute position of the corneal reflection, not the position relative to the center of the pupil.)

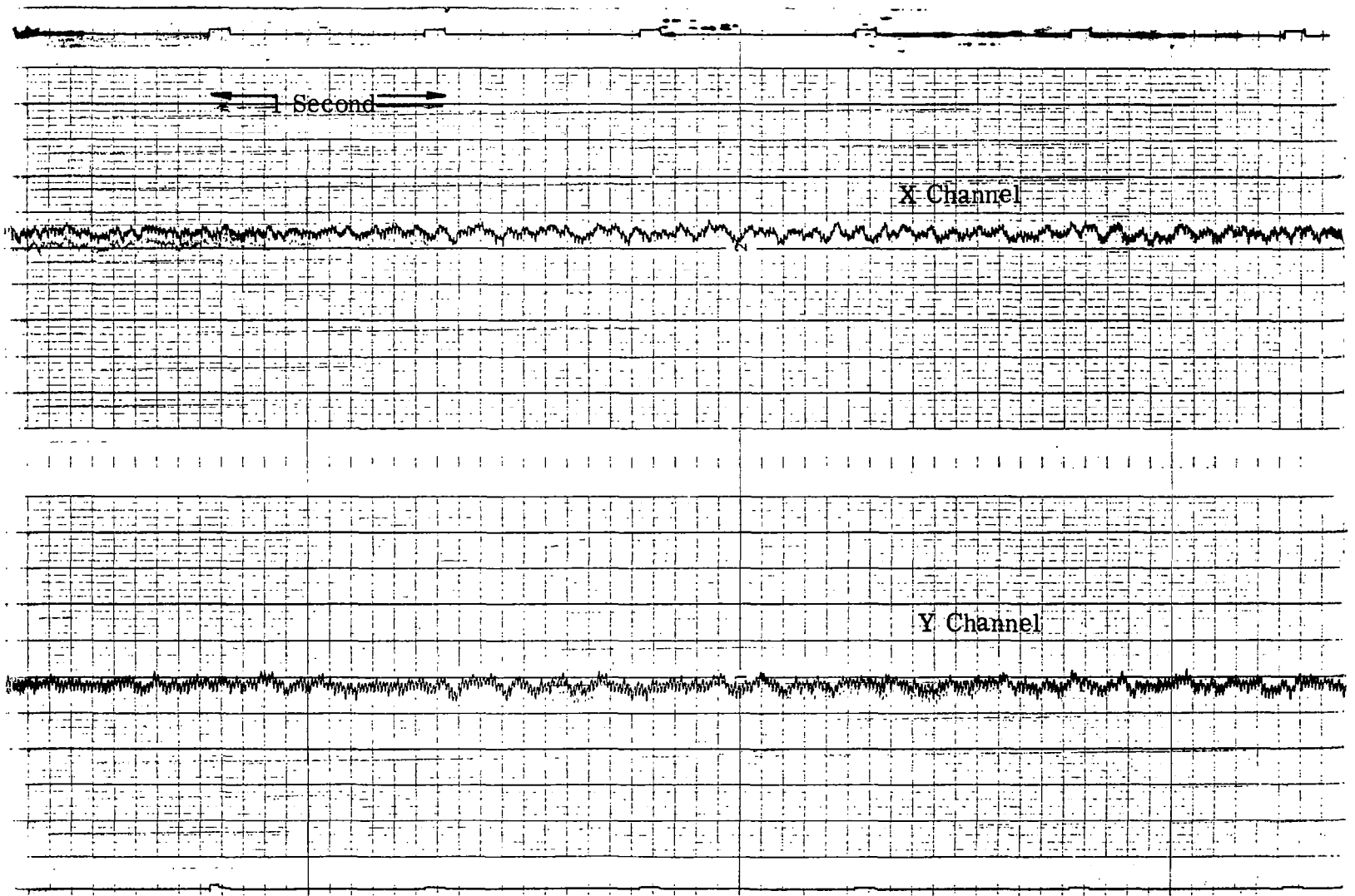

Figure 4. 6 PUPIL INTEGRATOR OUTPUT IN TRACKING
ARTIFICIAL PUPIL -- 20 mv/line



Figure 4.7 PUPIL INTEGRATOR OUTPUT WITH OCULOMETER IN
RESET MODE (All loops open) -- 20 mv/line

1 Second

X Channel



Y Channel



Vertical Scale: ↓ 0.1 volt, 0.2 mm,
4° eye angle at
20°/mm

Figure 4.8 ESTIMATED RANDOM NOISE IN TRACKING ARTIFICIAL PUPIL --
20 mv/line

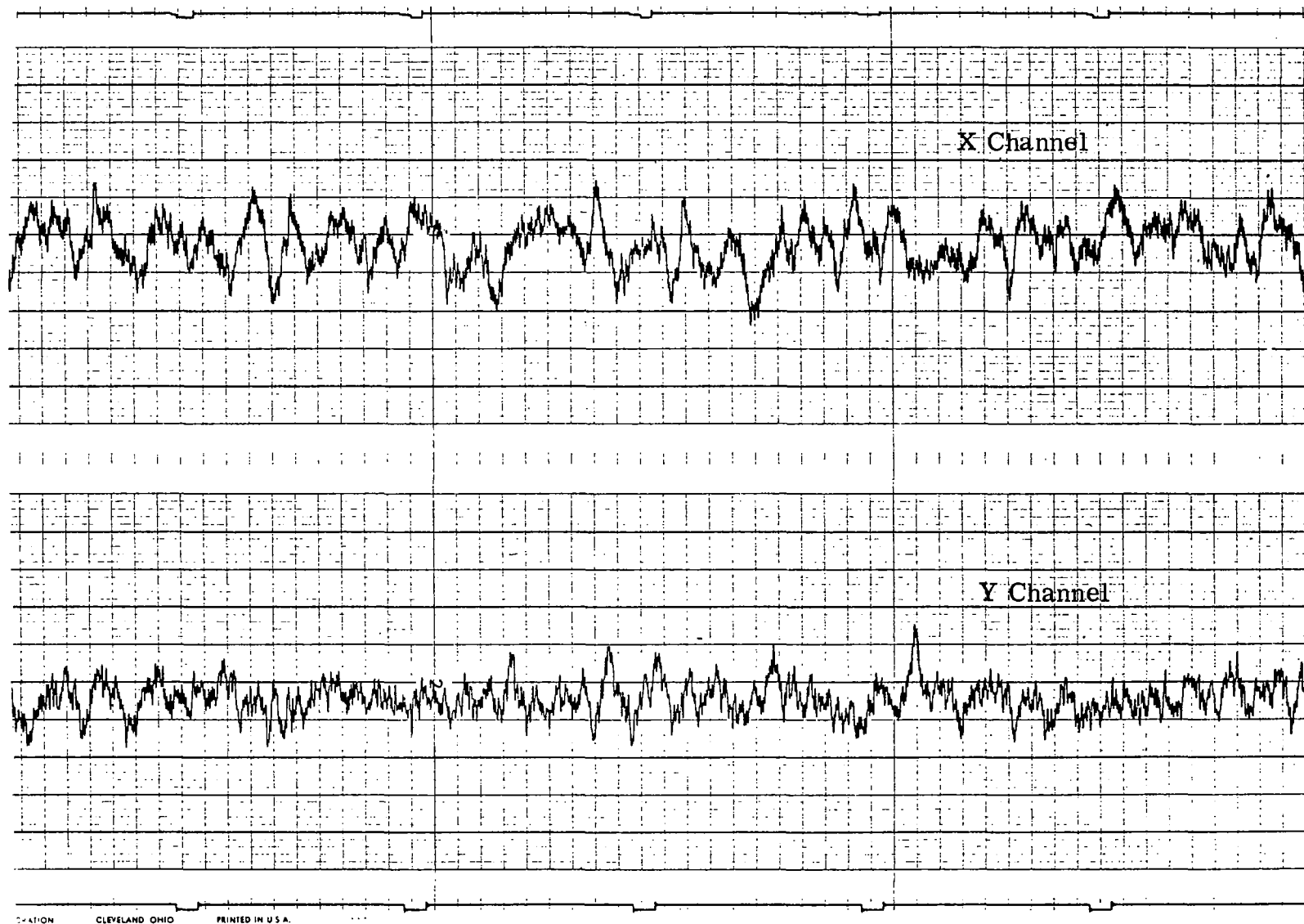

Figure 4.9 CORNEAL INTEGRATOR OUTPUT WHEN TRACKING REFLECTION IN ARTIFICIAL PUPIL -- 20 mv/line

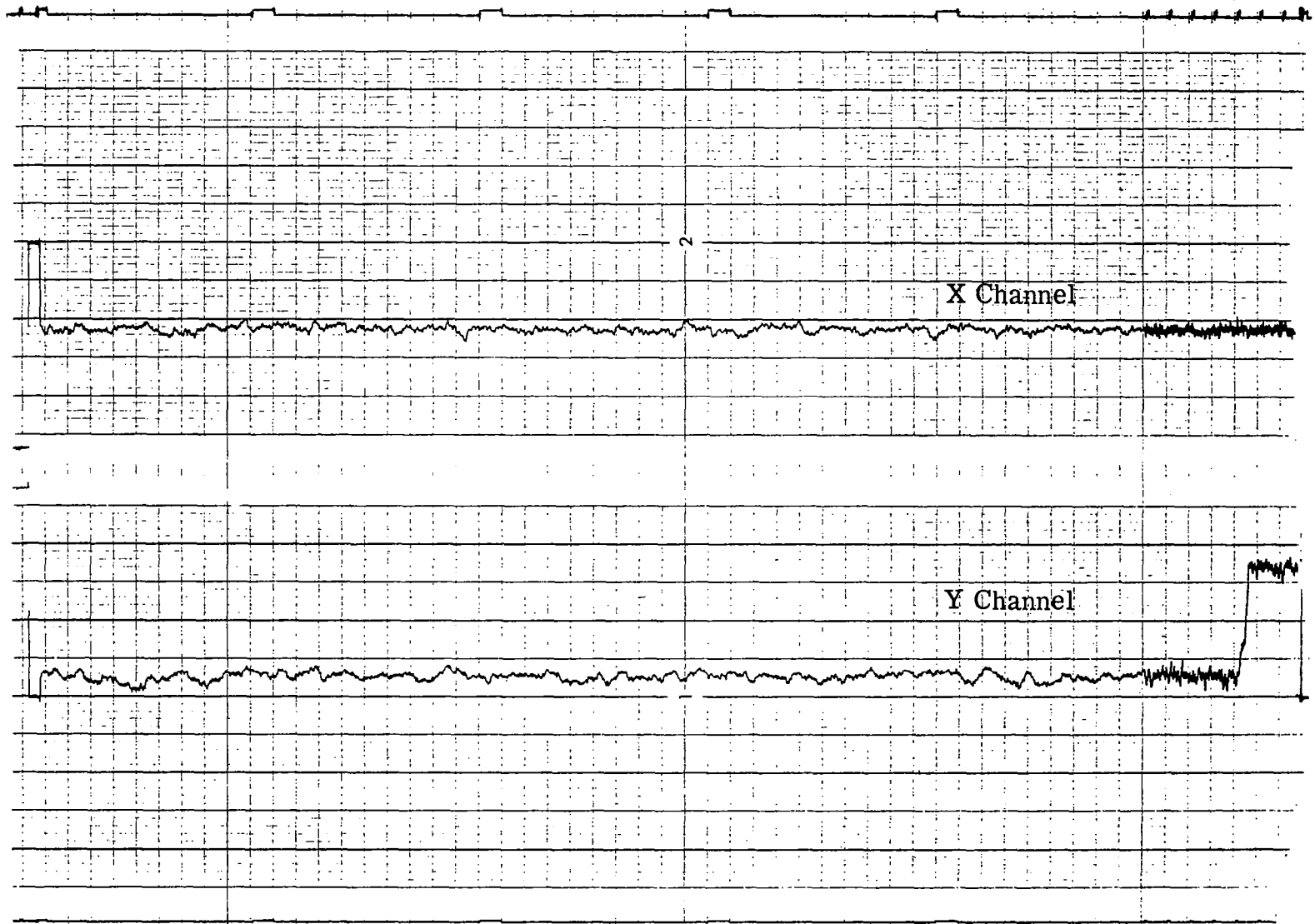

Figure 4. 10 CORNEAL INTEGRATOR OUTPUT WHEN TRACKING REFLECTION IN ARTIFICIAL PUPIL -- 100 mv/line

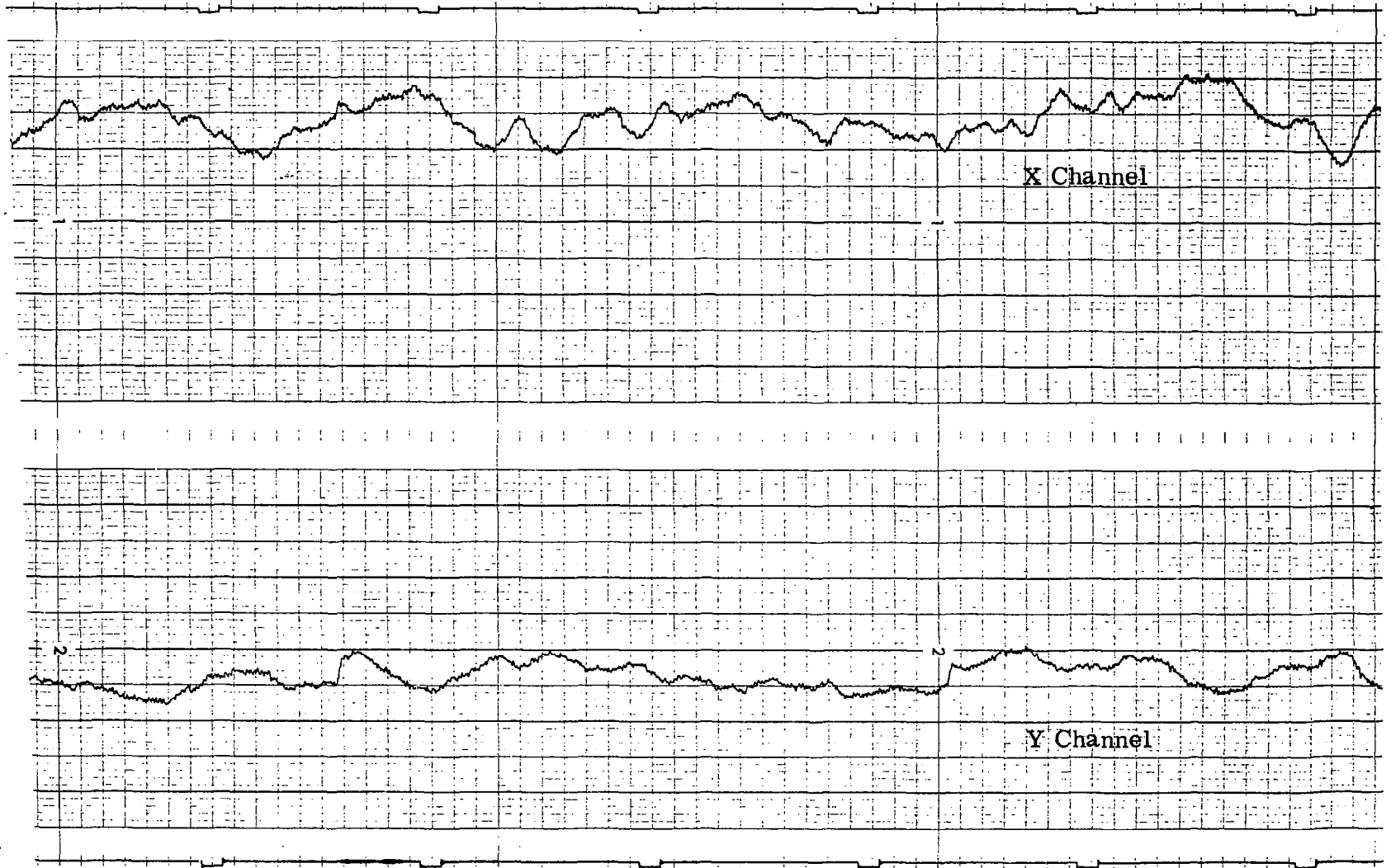

Figure 4.11 CORNEAL INTEGRATOR OUTPUT WHEN TRACKING REFLECTION
IN HUMAN EYE -- 100 mv/line

It is clear that as in the case of the pupil loop, part of the corneal loop noise is a 60 cps line frequency pickup. The remaining noise (i. e. , in Figure 4. 10) is slightly less in amplitude than that shown in Figure 4. 8 (pupil tracking noise). However, the recording sensitivity was five times greater for Figure 4. 8, so that in terms of voltage, the corneal tracking noise is about five times that of the pupil tracking noise. The deflection sensitivity (volts at tracking integrator output per mm deflection at the eye) is approximately 0. 5 volt/mm for the pupil loop and 2. 5 volts/mm for the corneal loop. This difference of sensitivity between the two loops just compensates for the difference of recorder sensitivities between Figures 4. 8 and 4. 10, so that in terms of positional, or angular, error at the eye the traces are directly comparable. This indicates that the RMS noise in the corneal loop, over a 20 cps bandwidth, is approximately 0. 8 degree. The combined noise of the pupil channel and the corneal channel is approximately 1. 1 degree over 20 cps, or 0. 3 degree over 1. 5 cps.

4. 2 MEASUREMENT OF EYE DIRECTION

4. 2. 1 Measurement Conditions

When eye direction is measured, both the corneal and pupil tracking loops are operative. The outputs from the pupil and corneal tracking integrators are combined in a simple computer circuit to yield measured eye direction:

$$\text{eye direction} = \lambda \text{ corneal integrator output} + \mu \text{ pupil position integrator}$$

where $0 < \lambda \leq 1$ (λ is a gain factor) and $-0. 1 < \mu < + 0. 1$ (μ represents a

small parallax correction to account for the fact that the corneal reflection is not exactly in the plane of the pupil).

The value of μ was set by trial and error in such a way as to minimize variations in the output signal (i. e. , measured eye direction) when the head was moved with the eye fixating a set point.

No independent measure of eye direction was employed. Eye direction was recorded as the eye followed a moving spot of light on an oscilloscope (Figure 4. 12). The magnification of the viewing system was such that a 1 cm displacement on the display scope corresponds to an angular displacement of about 3. 5 degrees at the eye.

The speed of the stimulus motion was chosen so that the eye was able to follow the stimulus point easily.

4. 2. 2 Measurement of Small Angular Displacements

A sawtooth stimulus motion with a 7 degree peak-to-peak amplitude was observed, and eye motion was recorded (Figures 4. 13 and 4. 14).

The RMS noise level in these recordings is approximately 1. 3 degrees. In addition, there are errors -- not due to noise -- of the order of 2 degrees RMS in the channel (x or y) of the stimulus motion and 1. 0 degree in the other channel. These non-noise errors are larger than the expected tracking error of the eye, which is of the order of 0. 15 degree to 0. 5 degree. (It is assumed for the present purpose that fixation was maintained to this accuracy during the test; hence most of the 2° non-noise errors must be ascribed to instrument limitations.)

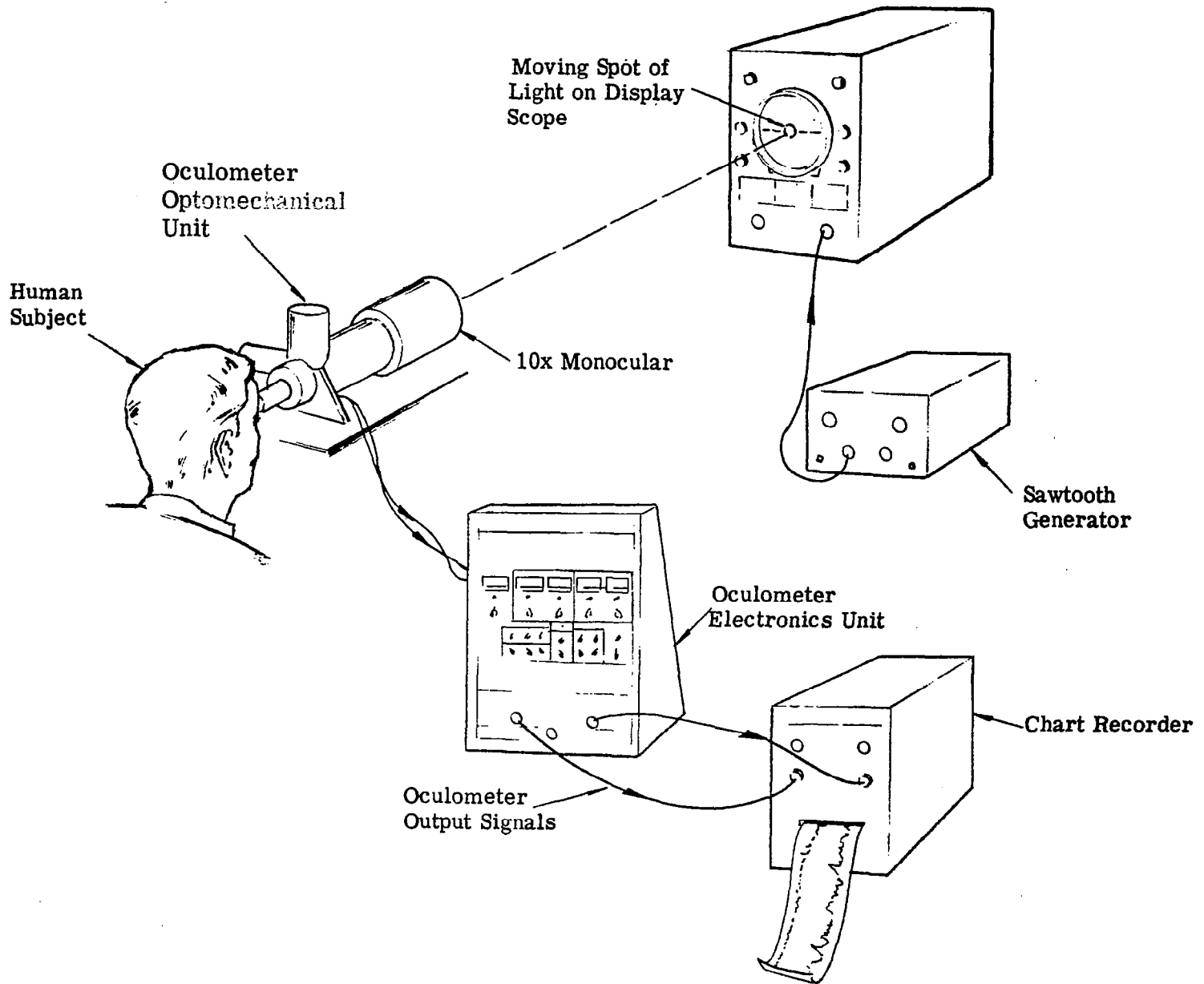

Figure 4.12 EYE TRACKING EXPERIMENTS

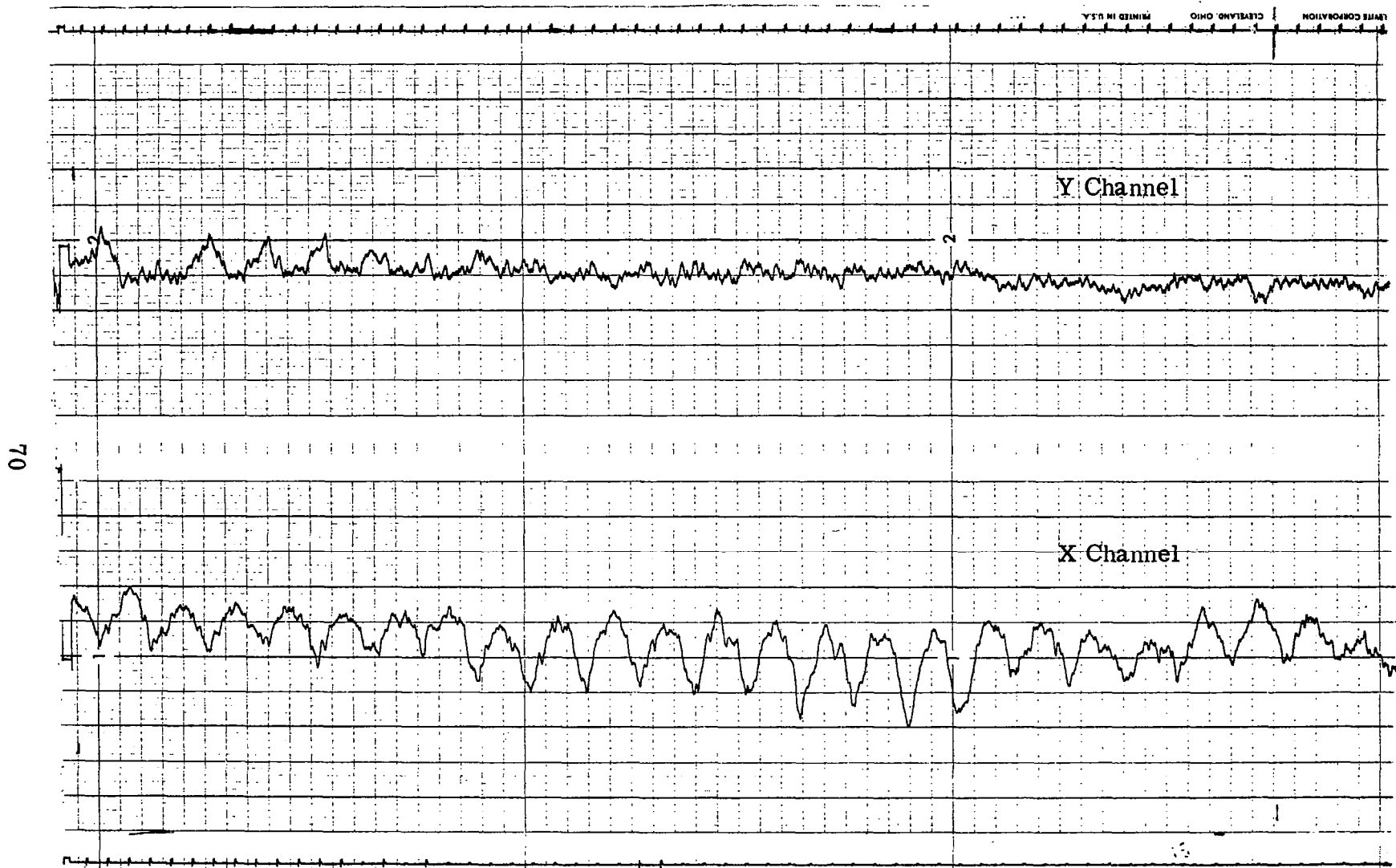

Figure 4.13 EYE DIRECTION MEASURED WITH SAWTOOTH
STIMULUS MOTION OF 7° IN X DIRECTION

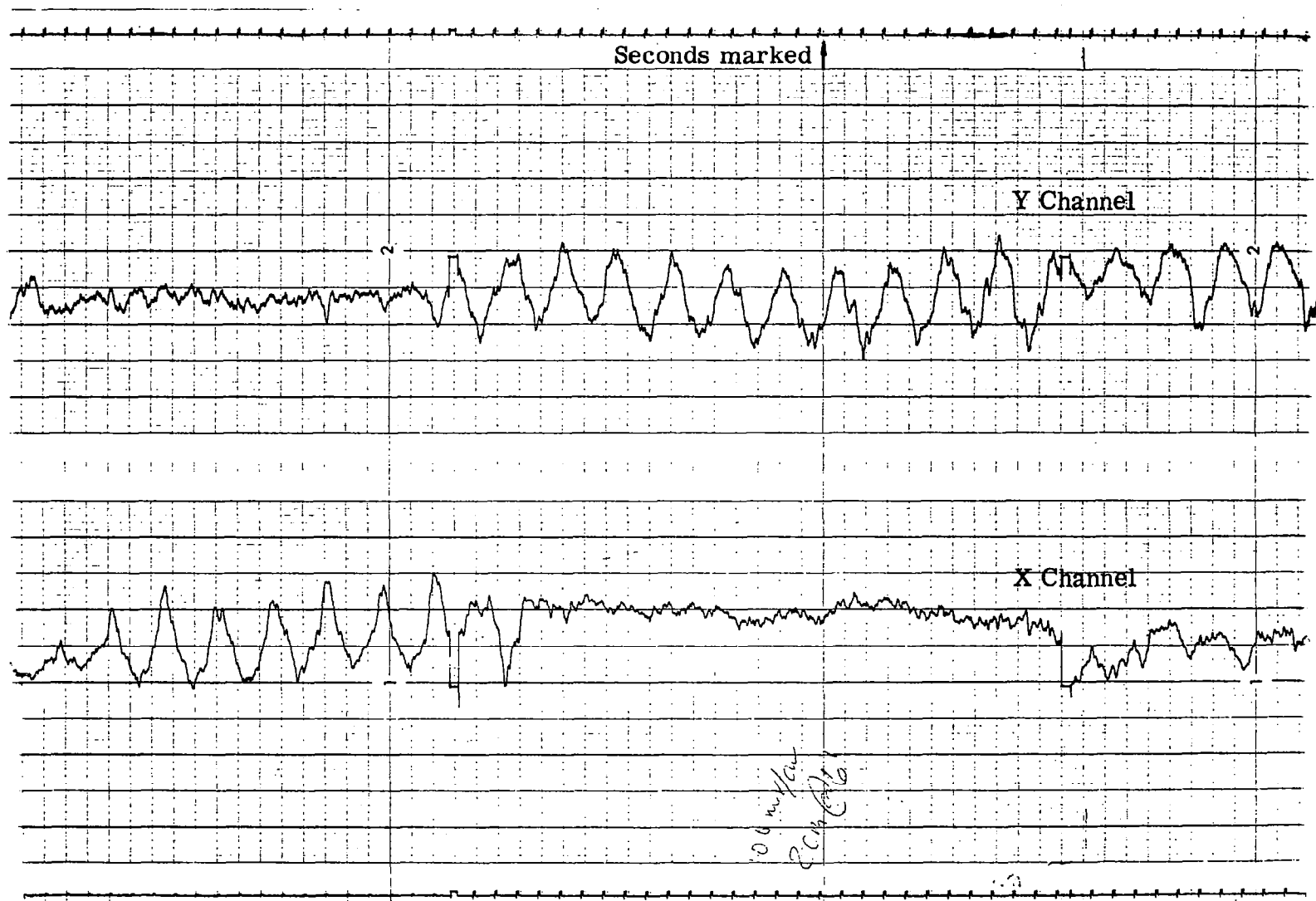

Figure 4.14 EYE DIRECTION MEASURED WITH SAWTOOTH STIMULUS MOTION OF 7° IN Y DIRECTION

4. 2. 3 Measurement of Large Angular Displacements

For this test the stimulus spot (Figure 4. 12) was moved by a sawtooth driving signal having a 10 cms peak-to-peak displacement in the x direction. The y setting of the spot was set successively at $y = 0$, $y = +2$, $y = +4$ cms. The stimulus spot was then moved in the y direction with a peak-to-peak sawtooth displacement of 11.5 cms, for x settings of 0, $+2$, and -4 cms.

At the viewing distance and magnification employed in these tests, a 1 cm displacement on the scope corresponded to 3.5 degrees of angular displacement at the eye.

Figure 4. 15 shows the eye recordings* made for angular displacements of 35 degrees peak-to-peak in the x direction, with $y = 0$ degrees (note that y (or x) = 0 is a nominal figure, not necessarily related to the direction of the optical axis of the oculometer). The x trace is linear, but the y trace shows a nonlinear effect. This is probably due to a pincushion distortion in the geometric relationship in the eyeball between eye direction and the position of the corneal reflection within the pupil (see Figure 4. 16). The effect of this geometrical eye distortion would be to introduce cross-talk between the x and y channels. The noise level and accuracy of the recordings are of the same order as that found in the small signal measurements (i. e. , 1 degree of noise plus 2 degrees of non-noise errors).

*In all the eye position recordings, a smooth line approximation has been drawn through the traces.

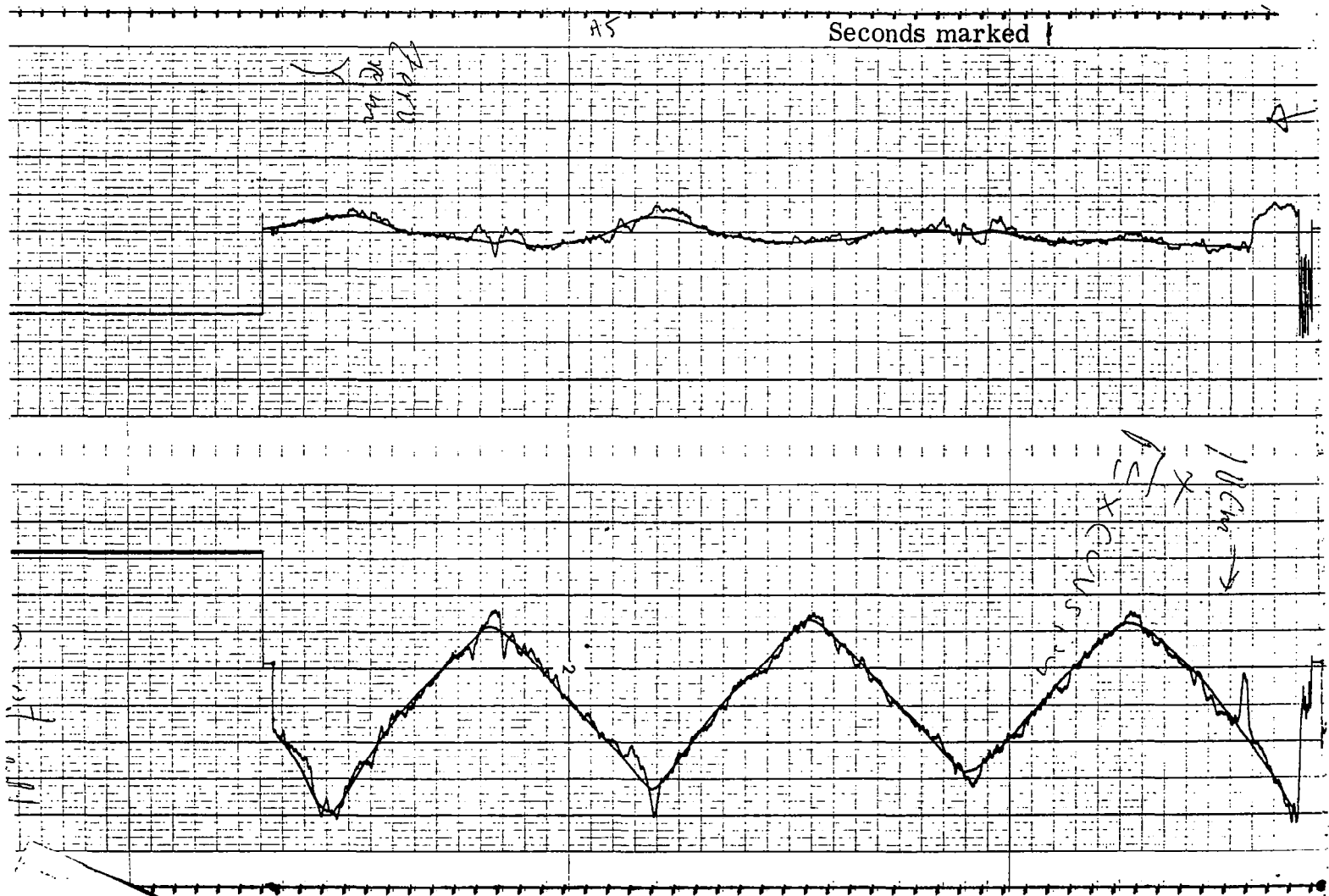

Figure 4.15 OCULOMETER OUTPUT WITH EYE TRACKING
 A $Y = 0^\circ$, $X = 35^\circ$, PEAK-TO-PEAK SAWTOOTH
 STIMULUS MOTION

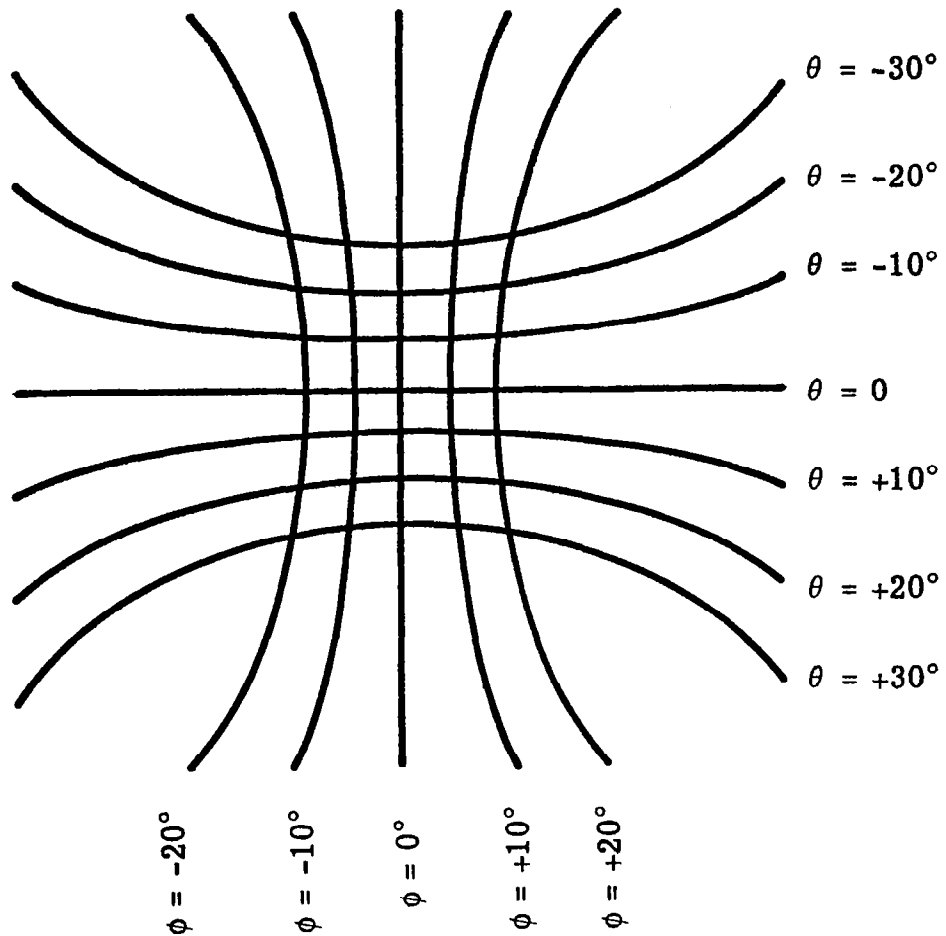

Figure 4.16 TYPICAL LOCUS OF CORNEAL REFLECTION WITHIN PUPIL, AS FUNCTION OF ANGULAR DIRECTION OF EYE, ASSUMING PINCUSHION DISTORTION (Illustrative only)

Figure 4.17 shows the recording for $y = 7$ degrees, $x = 35$ degrees peak to peak.

These traces are similar to those of Figure 4.15, except for the expected displacement of the y trace. The portions of the y trace marked with a ** are probably due to a spurious effect (e.g., eyelid droop, or acquisition of the corneal reflection of the eye illuminator by the pupil tracking system).

Eye motion recordings in response to stimulus displacements of $y = 14$ degrees, $x = 35$ degrees, peak to peak (Figure 4.18) show nonlinearity in the x trace. This is probably due to a distortion (nonlinearity) of the type illustrated in Figure 4.16.

Figures 4.19 and 4.20 show the recordings for sawtooths at $y = -7$ degrees and -14 degrees. The region marked *** in Figure 4.20 shows a temporary loss of track, probably due to a blink.

Figures 4.21 - 24 show similar recordings made with a vertical sawtooth displacement (40 degrees peak) at various settings of the x displacement.

Figures 4.15 - 4.24 show eye recordings made without any head position constraint beyond that required to align the entrance pupil of the eye with the exit pupil of the oculometer monocular. These recordings (with the "true" noise component smoothed out by estimation) are combined in Figures 4.25 and 4.26. The actual stimulus motions corresponding to Figures 4.25 and 4.26 are shown in Figures 4.27 and 4.28. Figures 4.25 and 4.26 clearly show the existence of nonlinearities, particularly in the channel with no stimulus motion.

Each of the recordings (Figures 4.15, 4.17 - 4.24) contains several cycles of motion. To illustrate the degree of repeatability, the cycles are shown superimposed in Figures 4.29, 4.30, and 4.31. The variation between the overlaid traces is more pronounced at the extremes of the sawtooth motion. There is a high probability that these particular variations are due to such spurious effects as eyelid droop or acquisition of the corneal reflection of the ring illuminator. Apart from these few extreme cases, the variations between the overlaid traces are less than ± 1.5 degrees.

4.3 ACQUISITION SYSTEM

The automatic acquisition system itself operated as intended and proved to be very effective. As soon as the eye is placed in front of the eyepiece, the search scan is replaced by the time-division-multiplex scan in track with the eye in both the corneal reflection and pupil/iris channels. Track is regained immediately after a blink.

A number of factors combined, however, to interfere with the automatic acquisition process in some cases. These factors relate mostly not to the acquisition system itself, but to various aspects of the oculometer which will be refined in further development:

1. A slight misalignment exists between the monocular and the ID optical systems. When the eye is placed at the center of the monocular exit pupil, it is not imaged at the center of the photocathode. Thus there is a greater chance that as the eye moves away from the central part of the monocular exit pupil, its image may move over the edge of the photocathode and track may thereby be lost.

2. The pupil acquisition system employs a square raster which must be wholly within the circular area of the photocathode and cannot, therefore, cover the whole area of the photocathode. (If the pupil acquisition scan were allowed to pass over the edge of the photocathode, at any point, a "black" signal would always be indicated at that point and the system would then remain locked in a false track mode with the scan passing over the edge of the photocathode.)
3. Operation of the oculometer in its present configuration (see Section 6.2.1) requires that the eye be completely open--i. e., with no obscuration of the top of the pupil by the eyelid or eyelashes. This may not occur naturally with some subjects.
4. The acquisition system is based upon two reference levels defining the brightness of the iris and the intensity of the corneal reflection. These levels have been adjusted for one particular subject and may not then be optimum for others.
5. As discussed below, in Section 4.4, the equipment has been operated with a fixed scan amplitude, adjusted to be optimum for one subject. But since pupil diameters vary significantly from subject to subject, this scan amplitude may not be optimum for some other subjects. An incorrect pupil scan diameter could result in unsatisfactory acquisition.

4.4 AUTOMATIC PUPIL ACQUISITION LOOP

Automatic control of the diameter of the pupil scan has been demonstrated with the equipment. However, further work is required to make this loop fully operational, as detailed below. It was found that in general, better results could be obtained with the present oculometer using a fixed scan diameter. All the data reported in this document was taken with a fixed pupil scan diameter.

Specific aspects of the automatic amplitude loop requiring further attention are as follows:

1. A tendency toward instability exists in the automatic acquisition process when there is automatic control of the pupil diameter. There is a transient effect on the pupil loop when the mode of operation switches from search to track. In some cases, this transient is sufficient to displace the scan enough to cause immediate loss of track.
2. The setting of the d-c reference level in the loop is too critical. If this level is set incorrectly, the scan either "blows-up" or shrinks to a point.

4.5 OPTICAL CHARACTERISTICS

The optical viewing characteristics of the oculometer are satisfactory, except that

1. The visible radiation used to illuminate the eye and form the corneal reflection is disturbing to the eye.
2. The edges of the beam splitters obstruct part of the monocular view.

These limitations were consciously incurred in order to achieve the specific program objectives as economically as possible. (See Sections 6.2.3 and 6.2.4.)

4.6 SUMMARY OF RESULTS

The recordings discussed in Section 4.2 have been analyzed and the following conclusions have been drawn:

Noise (True Random Noise): 0.3 degree RMS over 1.5 cps.

Linearity: Substantial nonlinearity is indicated, probably due to a pincushion distortion in the geometry of the eyeball, as illustrated in Figure 4.16.

Axis Crosstalk: 20% maximum, due to nonlinearity.

Small Signal Errors (other than noise): ± 2 degrees.

Repeatability with large signals (i. e., excluding errors due to noise and nonlinearities): ± 1.5 degrees.

The automatic acquisition system has been shown to be satisfactory in principle, but design refinements are necessary to make it fully operational.

Several improvements should be made in the automatic pupil amplitude loop.

There is partial obscuration of the monocular field by the beam splitters. The illuminating radiation is visible.

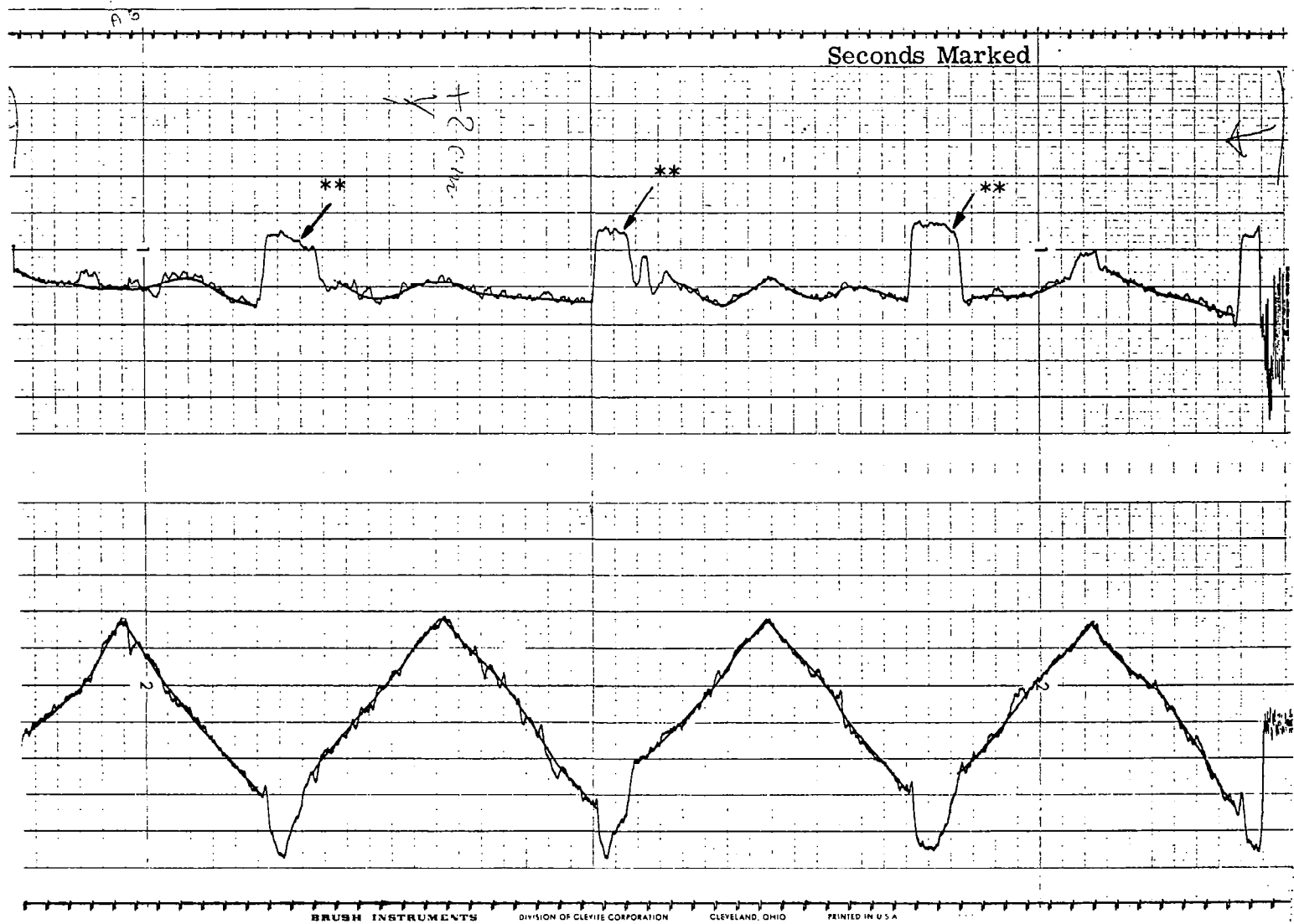

Figure 4.17 OCULOMETER OUTPUT WITH EYE TRACKING A
Y = +7°, X = 35°, PEAK-TO-PEAK SAWTOOTH
STIMULUS MOTION

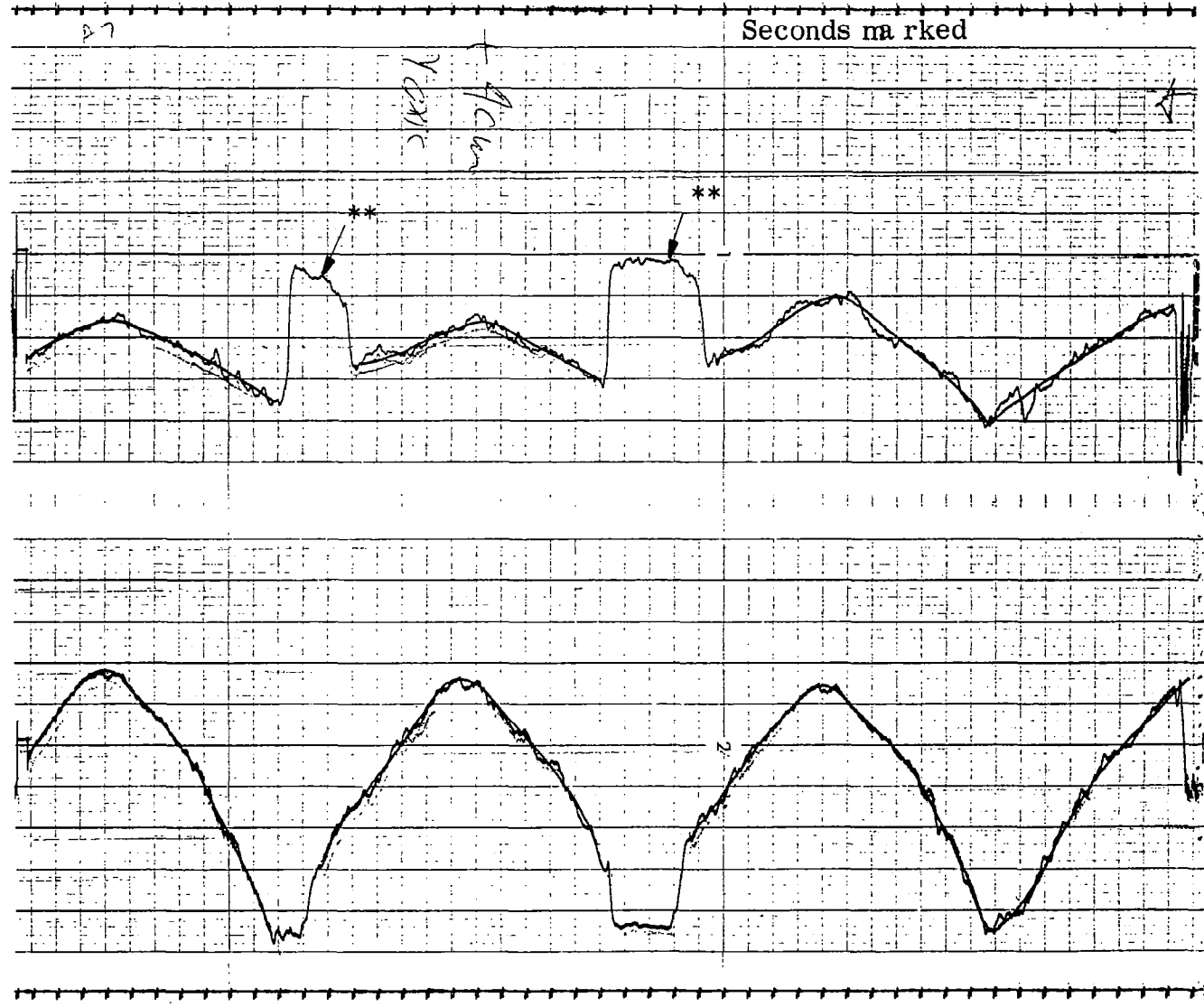

Figure 4.18 OCULOMETER OUTPUT WITH EYE TRACKING A
Y = +14°, X = 35°, PEAK-TO-PEAK STIMULUS
MOTION

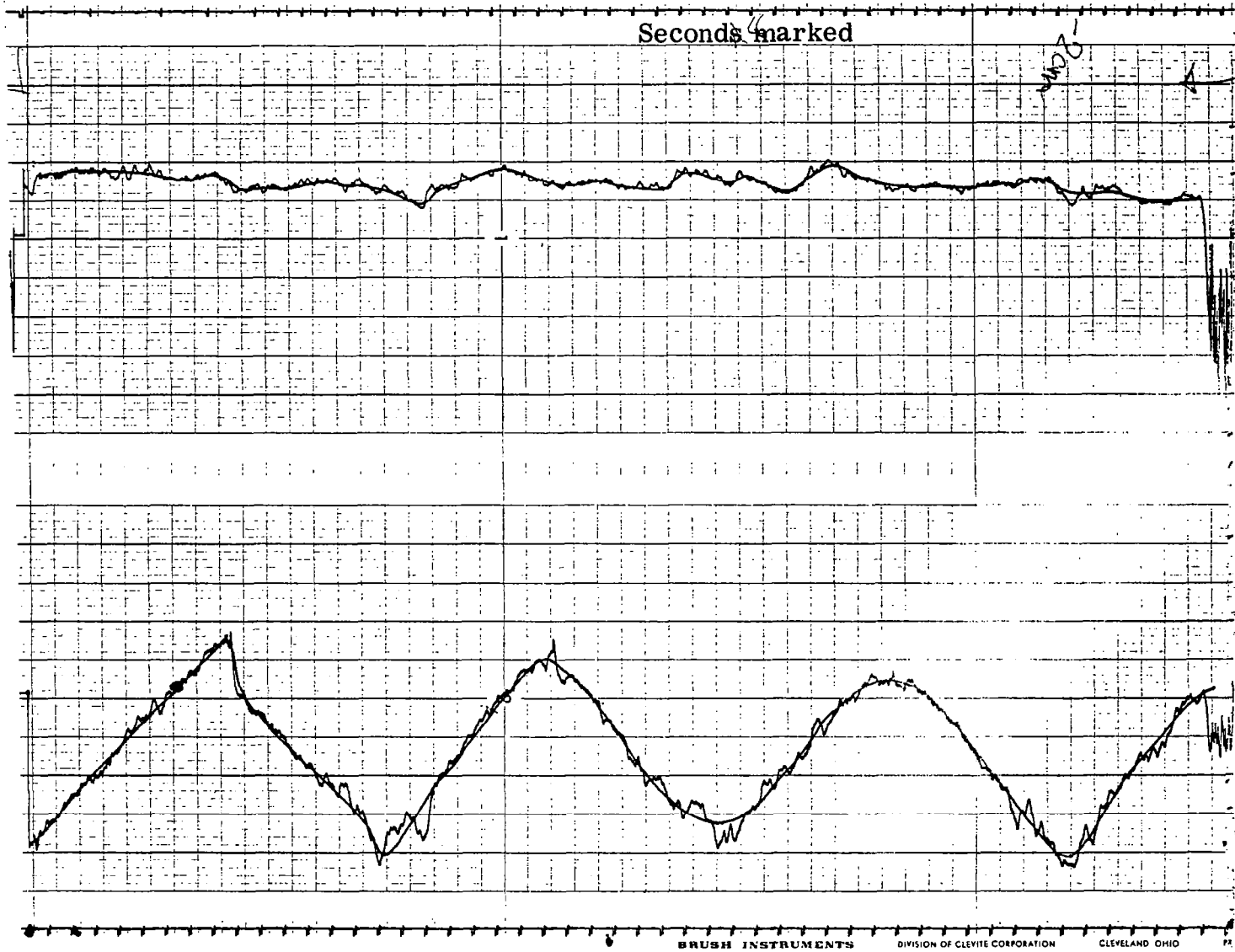

Figure 4.19 OCULOMETER OUTPUT WITH EYE TRACKING A
Y = -7° , X = 35° , PEAK-TO-PEAK STIMULUS MOTION

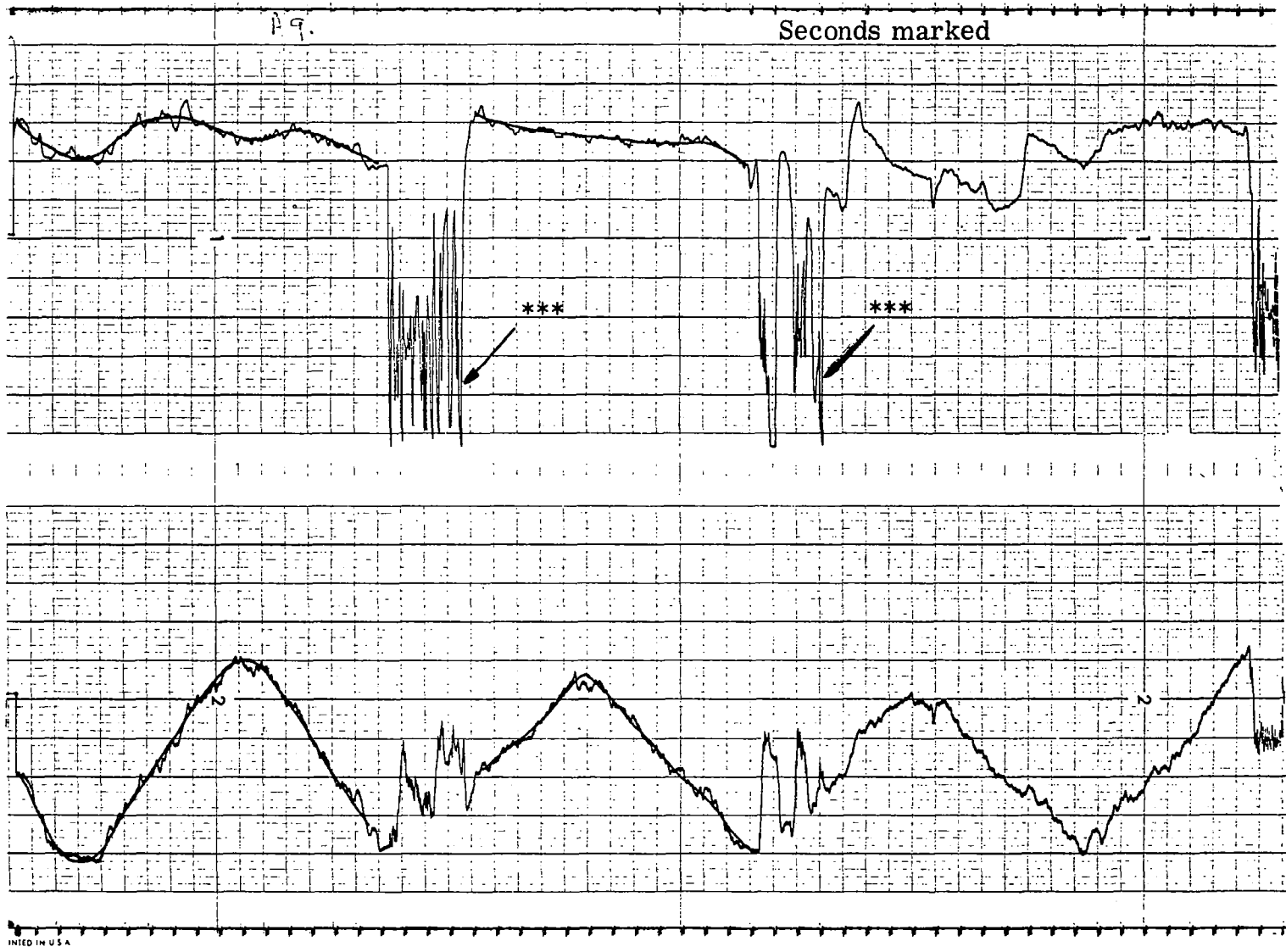

Figure 4.20 OCULOMETER OUTPUT WITH EYE TRACKING A
Y = -14°, X = 35°, PEAK-TO-PEAK STIMULUS MOTION

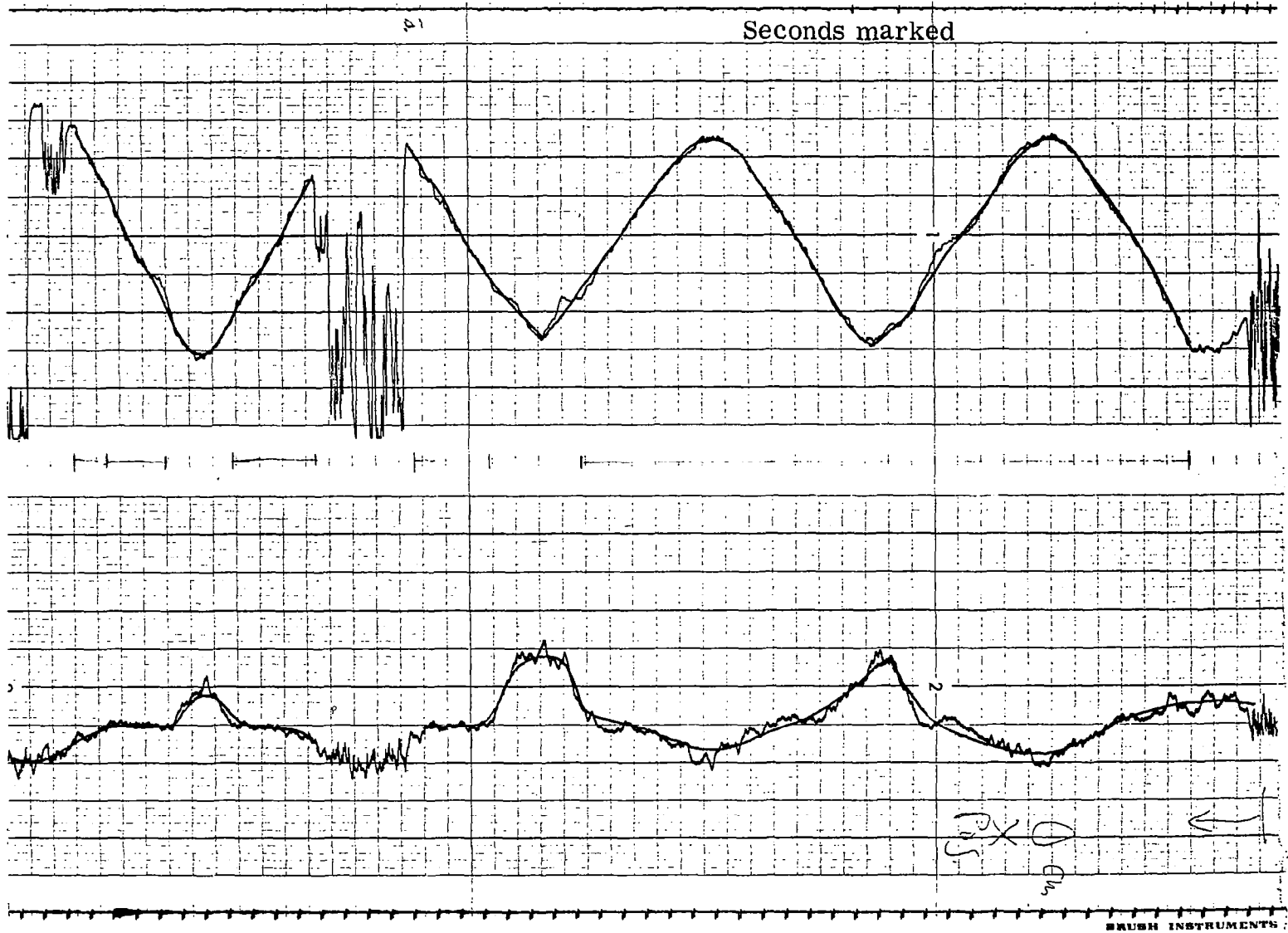

Figure 4.21 OCULOMETER OUTPUT WITH EYE TRACKING A
 $Y = 40^\circ$, $X = 0$, PEAK-TO-PEAK STIMULUS MOTION

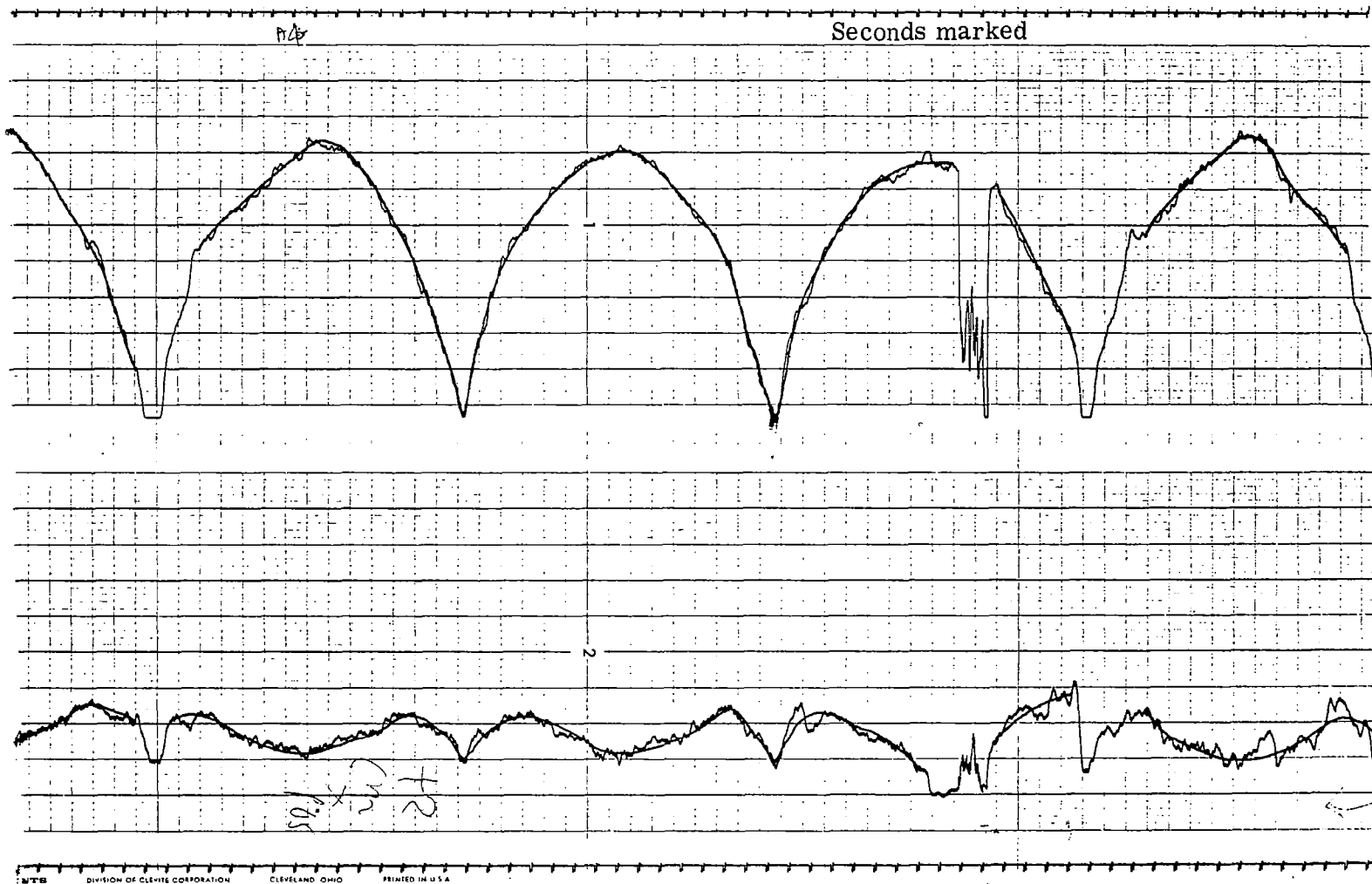

Figure 4.22 OCULOMETER OUTPUT WITH EYE TRACKING AN
 $X = +7^\circ$, $Y = 40^\circ$, PEAK-TO-PEAK STIMULUS MOTION

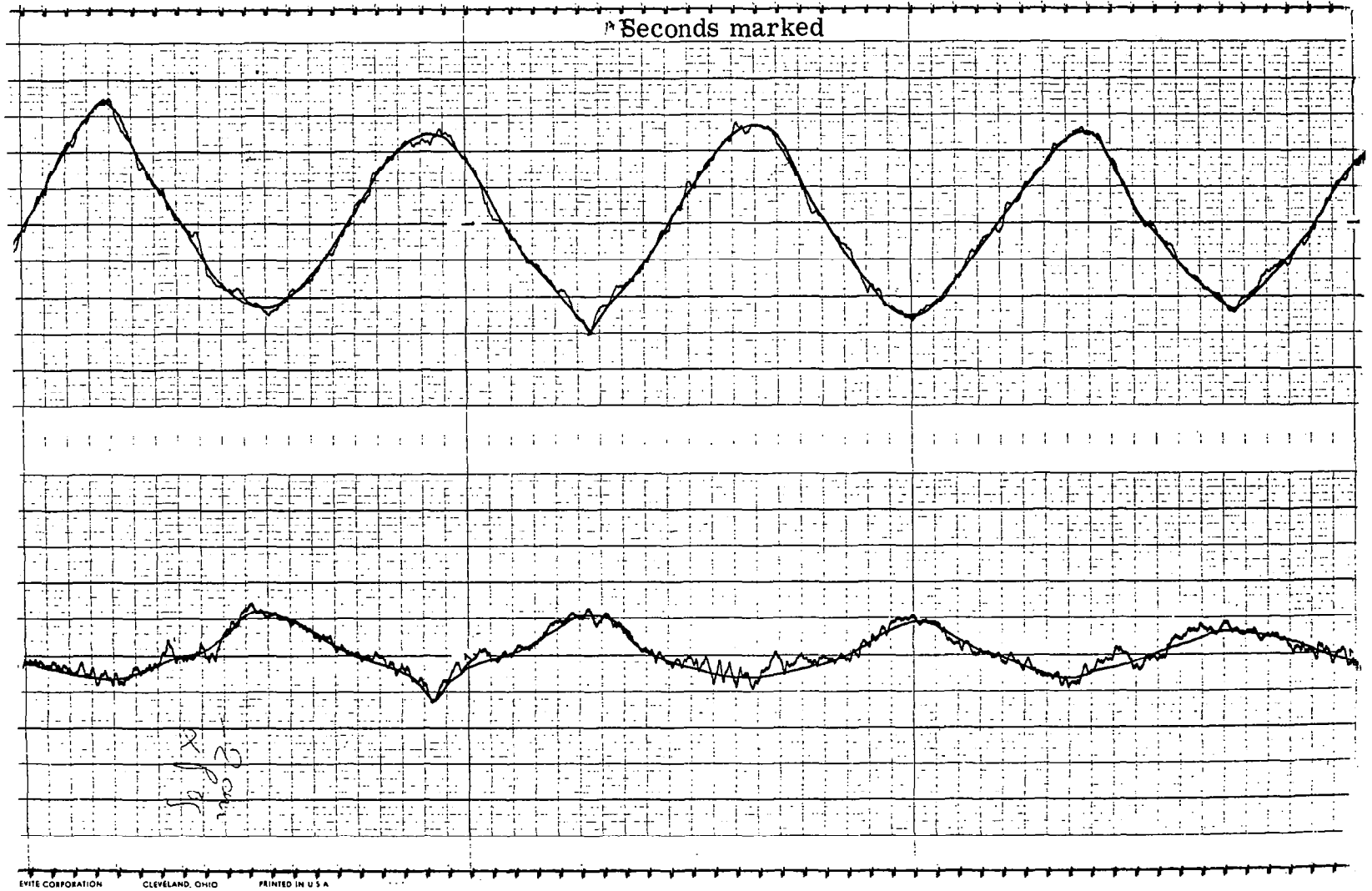

Figure 4.23 OCULOMETER OUTPUT WITH EYE TRACKING AN
 $x = -7^\circ$, $Y = 40^\circ$, PEAK-TO-PEAK STIMULUS MOTION

A3

Seconds marked

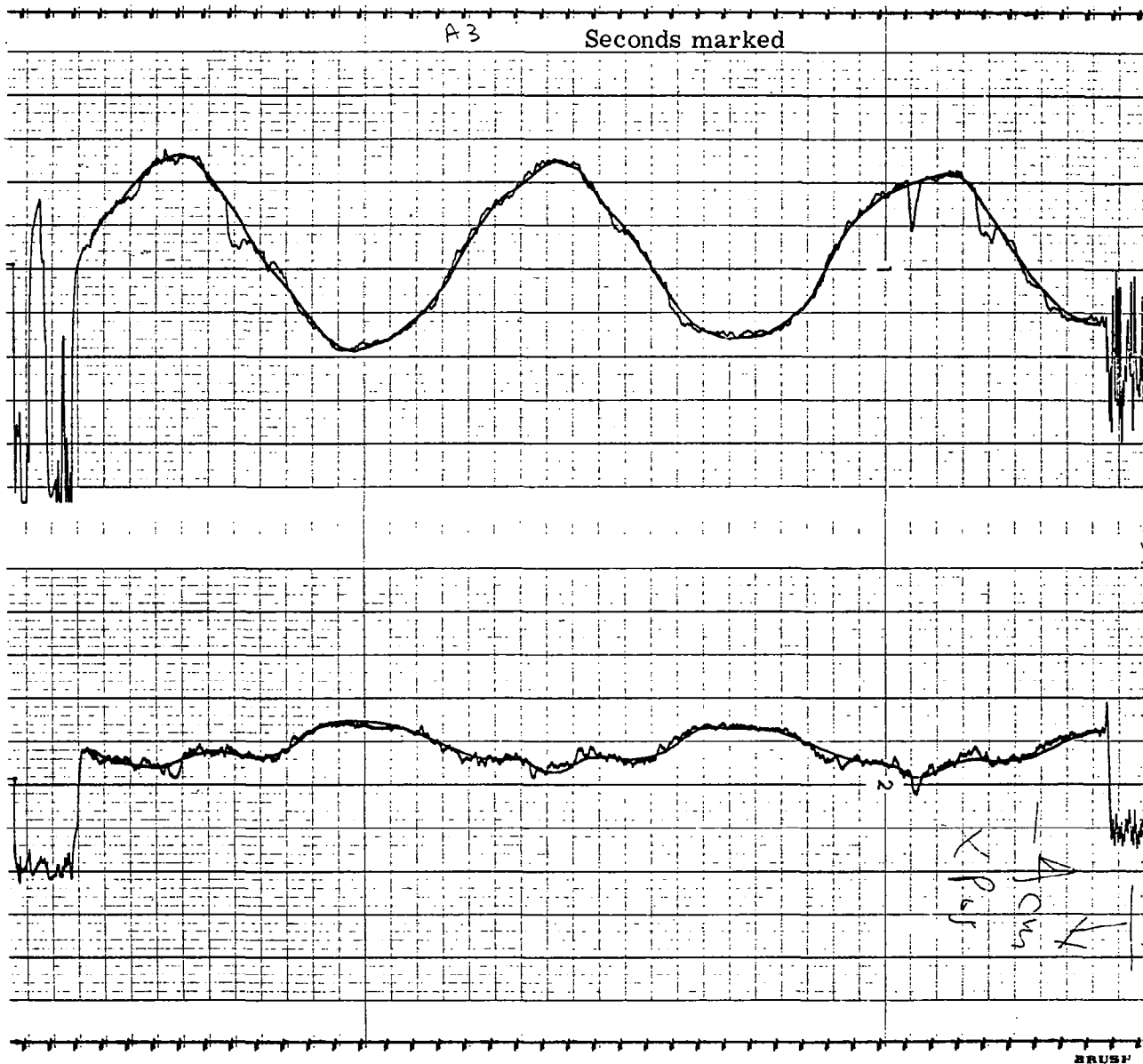
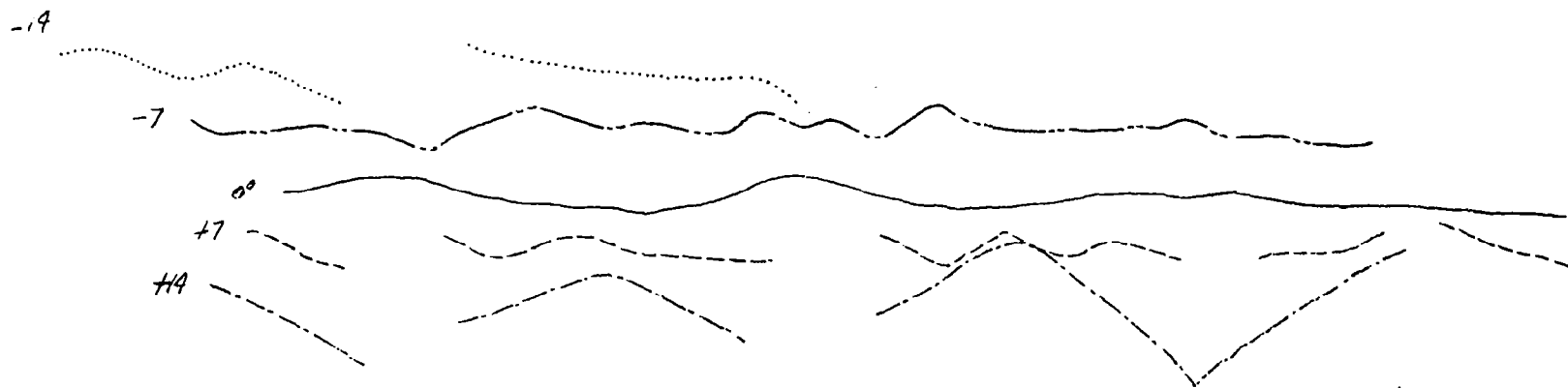

Figure 4.24 OCULOMETER OUTPUT WITH EYE TRACKING AN
X = -14°, Y = 40°, PEAK-TO-PEAK STIMULUS MOTION



88

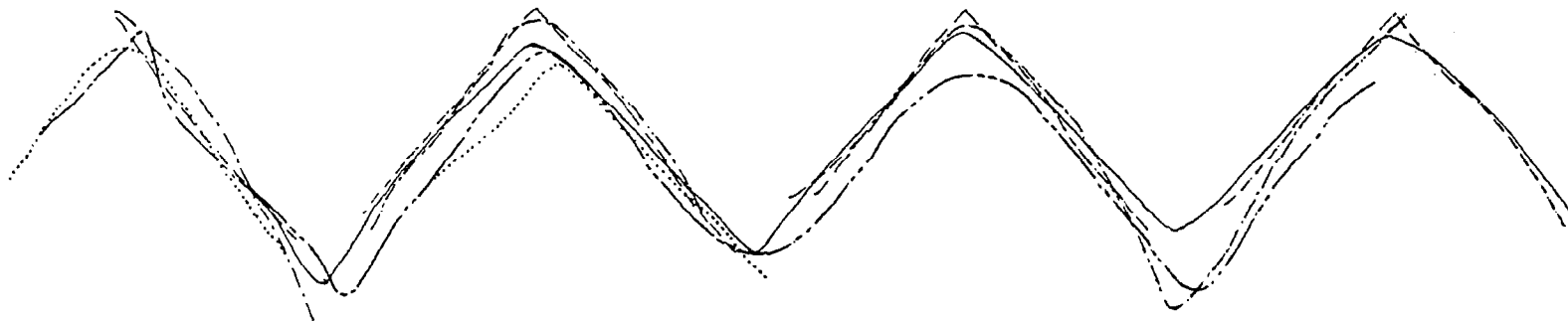

Figure 4.25 EYE MOVEMENTS RECORDED FOR STIMULUS DISPLACEMENTS OF 35° , PEAK-TO-PEAK, IN HORIZONTAL AXIS

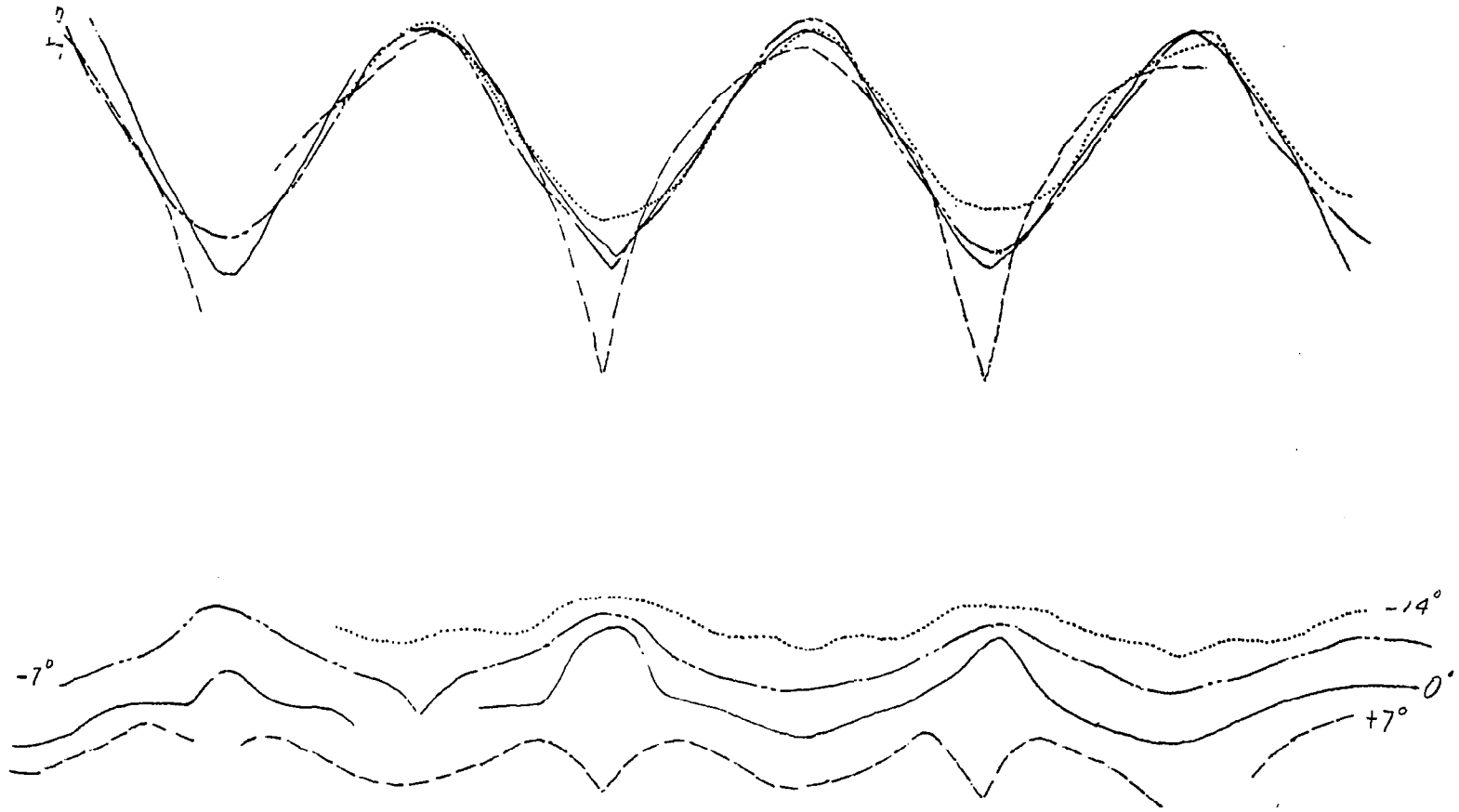
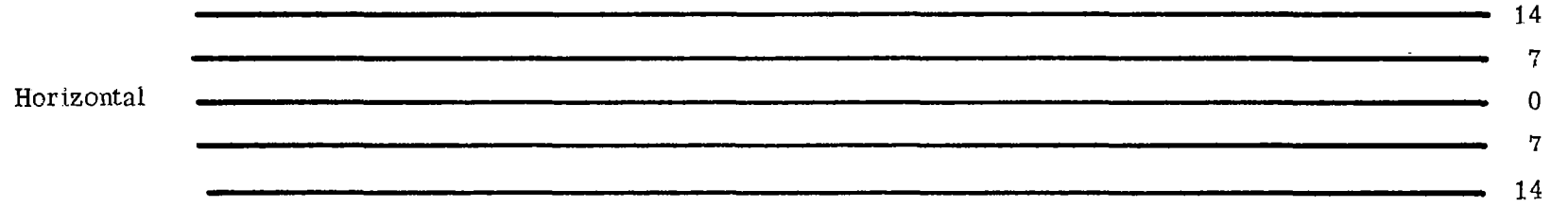

Figure 4.26 EYE MOVEMENTS RECORDED FOR STIMULUS DISPLACEMENT OF 40°, PEAK-TO-PEAK IN VERTICAL AXIS



06

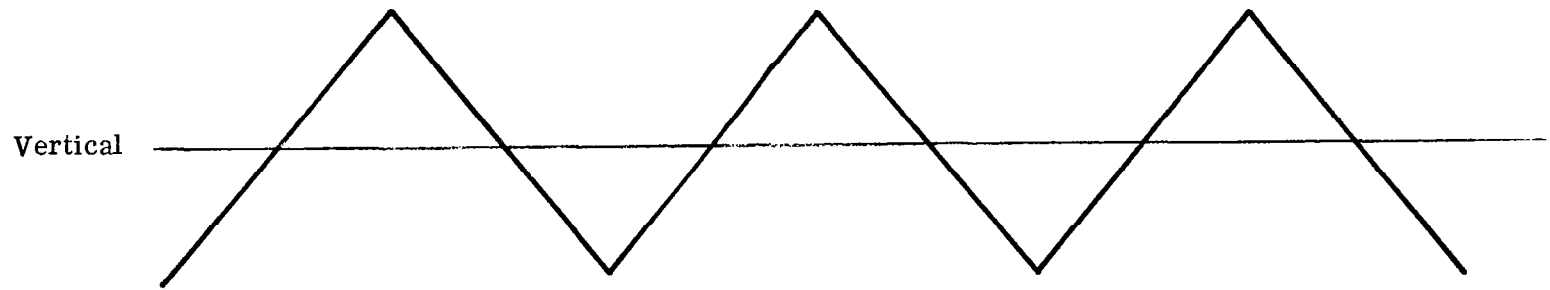

Figure 4.27 STIMULUS MOTION FOR TESTS SHOWN IN FIGURE 4.25

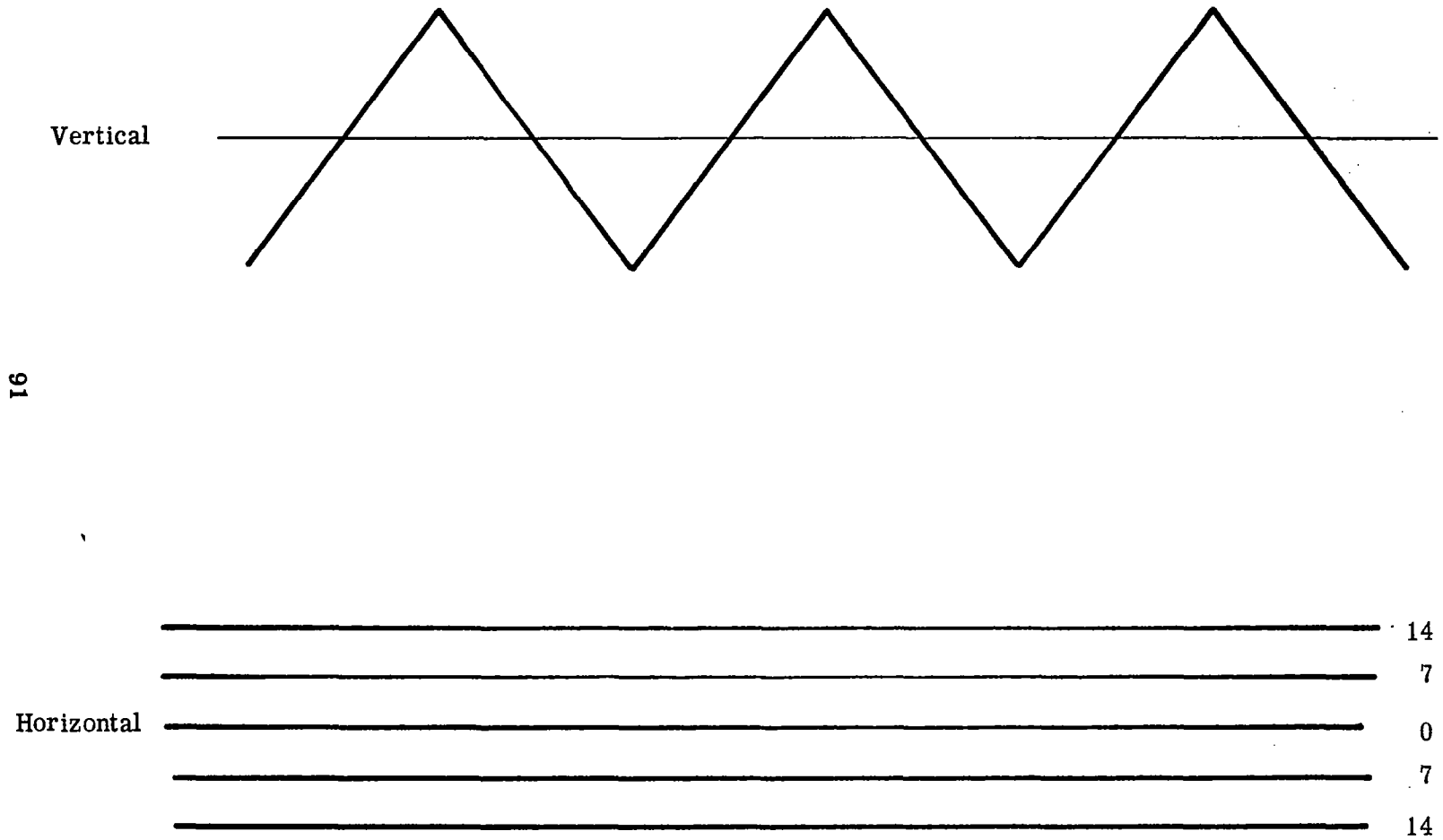

Figure 4. 28 STIMULUS MOTION FOR TESTS SHOWN IN FIGURE 4. 26

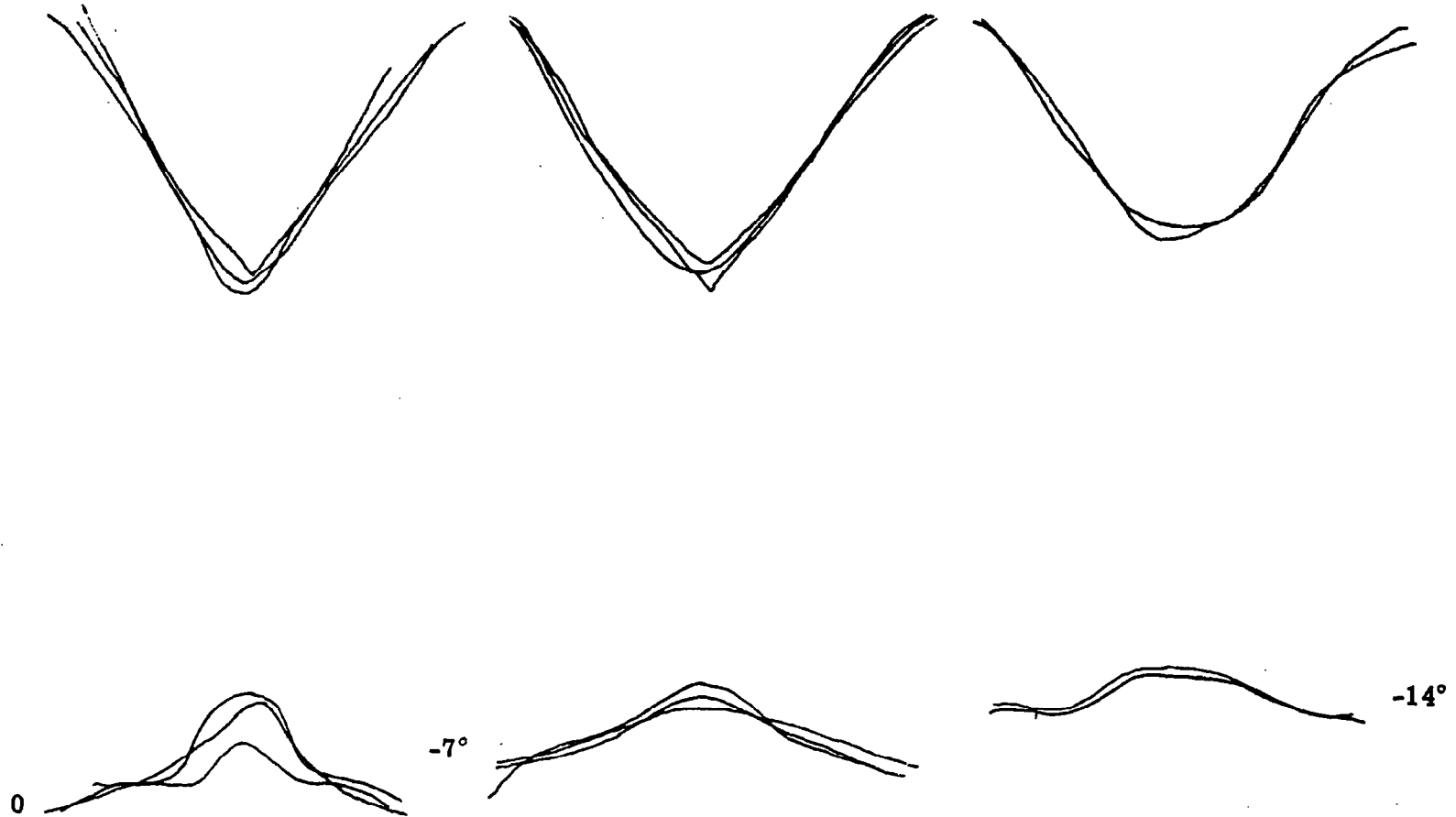

Figure 4.29 SUPERPOSITION OF EYE RECORDINGS FOR
X = 0, -7°, -14°, AND Y = 40°, PEAK-TO-
PEAK, SAWTOOTH

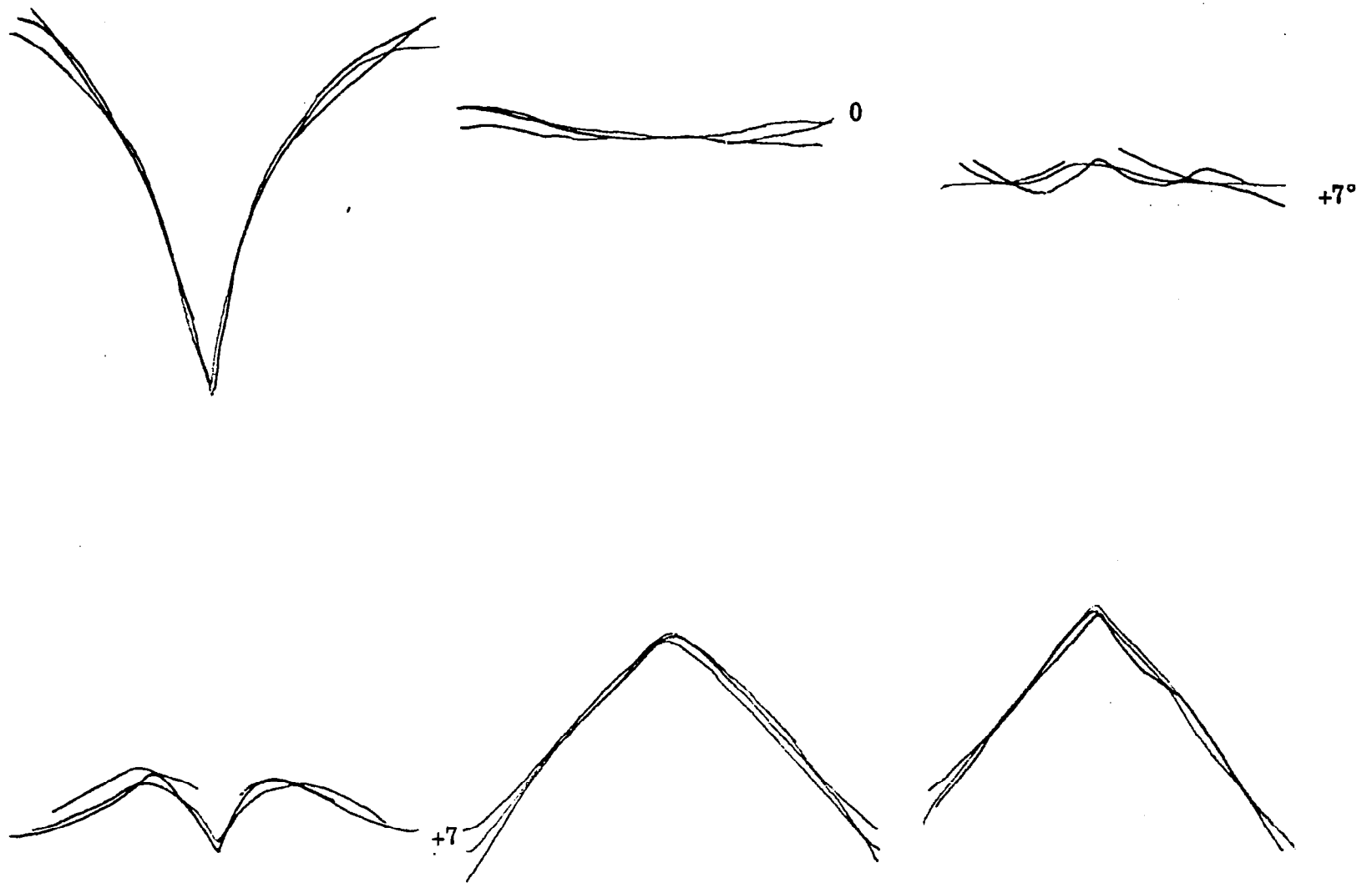
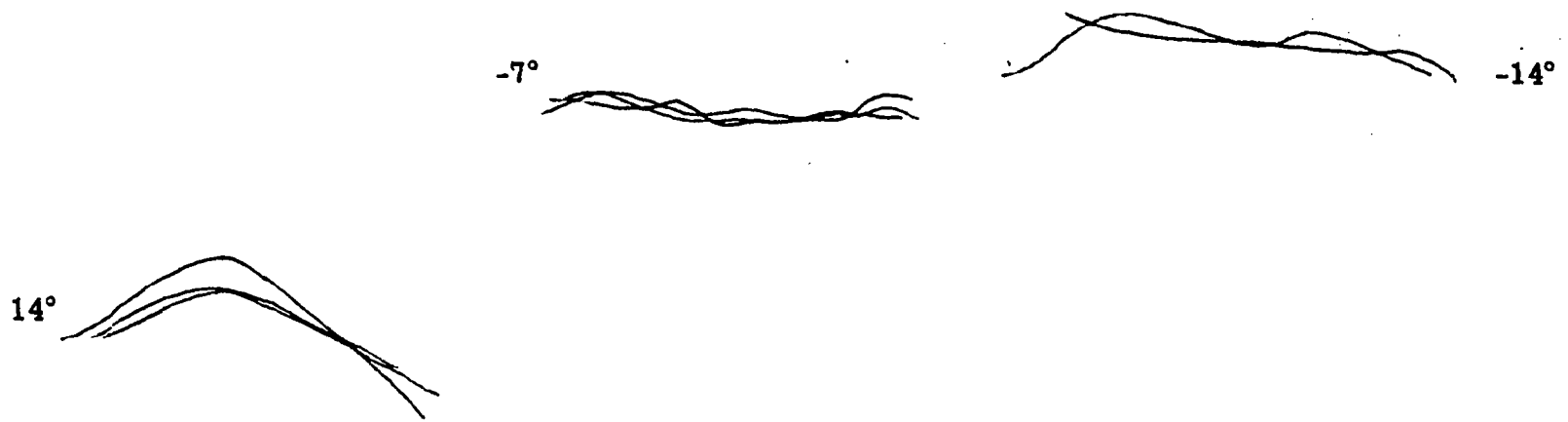

Figure 4.30 SUPERPOSITION OF EYE RECORDINGS FOR
X = +7°, Y = 40°, SAWTOOTH, AND Y = 0,
+7°, X = 35°, SAWTOOTH



94

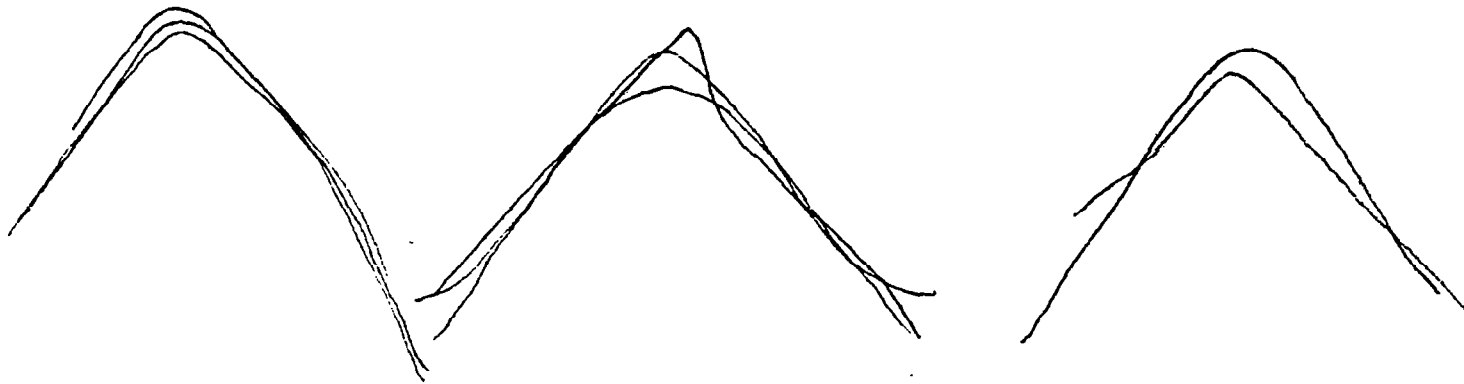

Figure 4. 31 SUPERPOSITION OF EYE RECORDINGS FOR
Y = $+14^\circ$, -7° , -14° , X = 35° , SAWTOOTH

SECTION 5

RESULTS OF THE APPLICATIONS STUDY

5.1 SUMMARY

Appendix A discusses in detail the various applications of the oculometer that have been considered. This section summarizes the results of the study.

The main applications recognized at this time are

1. An astronaut's tracking telescope--automatic (oculometric) control of the pointing and zoom of the high power viewer that an orbiting astronaut will use to acquire and examine surface details of the earth at the highest possible resolution.
2. An astronaut's maneuvering unit (AMU)--use of a helmet-mounted oculometer to facilitate the astronaut's communication of his desired motion to the AMU propulsion unit.
3. Monitoring a human subject--for example, to determine exactly where a pilot is looking as he experiences various conditions and emergencies in a flight simulator. Another example is to determine the state of mental alertness (arousal) of a subject as he performs his normal duties, through continuous measurement of his eye pointing direction.

5.2 ASTRONAUT'S TRACKING TELESCOPE

If an orbiting astronaut wishes to view the surface of the earth with the maximum possible resolution of surface detail, he will use a viewer having a magnification of about 20X - 40X. With such magnification, however, his field of view will be very small. For this reason a magnification of 20X - 40X can not be used satisfactorily for acquisition of

surface detail. At high magnification, moreover, the pointing control of the telescope will be very critical, as it must then track the surface detail very accurately.

In view of the very short time (20 - 30 seconds) available for observing surface detail while passing over it in orbit, manual control of the astronaut's telescope may not be adequate. The astronaut must perform a search task at low power, increase the magnification (without losing track of the acquired detail) for observation of specific detail, and then perform an accurate tracking task to keep the detail in view (or to explore immediately adjacent areas). It is doubtful that these tasks could be performed at full efficiency within 20 - 30 seconds, without some degree of automatic control.

Sections 2.1.1 and 2.1.2 of Appendix A describe an oculometric system for the automatic control of both the pointing and the degree of zoom of a tracking telescope. Both zoom and pointing angle will be automatically adjusted to match the viewing requirements of the astronaut. The advantage of oculometric control is that it may allow the astronaut to absorb more of the information that he views. This would not be possible with conventional manual control.

5.3 ASTRONAUT MANEUVERING UNIT (AMU)

The use of the helmet-mounted oculometer in an AMU can simplify the commands that the astronaut must give to the propulsion system.

In general, three commands should be given for any rotational motion and three commands for any translational motion (corresponding to the three

degrees of freedom in each case). However, the desired motion of the astronaut will generally be along or about the principal axes of his own mental frame of reference. This axis system will coincide with the AMU propulsion unit frame of reference only when the astronaut is looking straight ahead with his head in a normal position.

Through continuous measurement of eye direction, it may be possible to determine at all times the astronaut's frame of reference, and then arrange for his motion commands to be transformed automatically from his own axis system to that of the AMU. As previously noted, these commands will generally be along or about his own principal axes and therefore can be expressed by one number, instead of three. The reduction of the number of commands from three to one is an advantage not only because it simplifies the communication problem between the astronaut and his AMU, but also because it frees the astronaut from the need to perform the mental calculations involved in an axes transformation.

5.4 MEASUREMENT APPLICATIONS

In the helmet- or head-mounted configuration, the oculometer offers the possibility of continuously measuring and recording a subject's eye pointing direction while he is performing his normal activities.

This could be extremely valuable in a number of situations. In a flight simulator, it may be very important to know just where a pilot is looking during critical phases of a flight profile. For example, it could be determined that a pilot failed to take the correct control action (to recover from an emergency) because he did not fixate an important instrument at the time he attempted to take that action. At present, considerable reliance must

be placed on the subjective reports of the pilot in such situations--which is obviously not as satisfactory as objective measurement.

Another possibility for the oculometer is a means of determining the degree of mental alertness of a subject. Further work should be done to explore this possibility.

The eyes provide the major channel of sensory information to the brain. To an important extent, the amount of information derived by the eye from its environment must depend on the way in which the very fine beam of foveal vision is swept over the viewed scene. Consideration of the sensory capability of the retina, as a function of position from the fovea, emphasizes the significance of the narrow foveal beam. Figure 5.1 shows the estimated density of optic nerve fibers as a function of position on the retina. The fiber density function is critical in the present context, because it sets an upper limit to the sensory data flux (in bits per second per unit area) from each part of the retina to the brain. It appears, therefore, that the oculometer by recording the motion of the foveal beam could serve as an indicator of "the level of activity" in the visual sensory channel.

It is reasonable to take the next step of associating the level of activity in this primary sensory input channel with the degree of mental alertness of the subject. This then implies a relationship between eye pointing direction and mental alertness.

5.5 RECOMMENDATIONS

In order to pursue further the two main potential control applications of the oculometer, it is recommended that the following work be done:

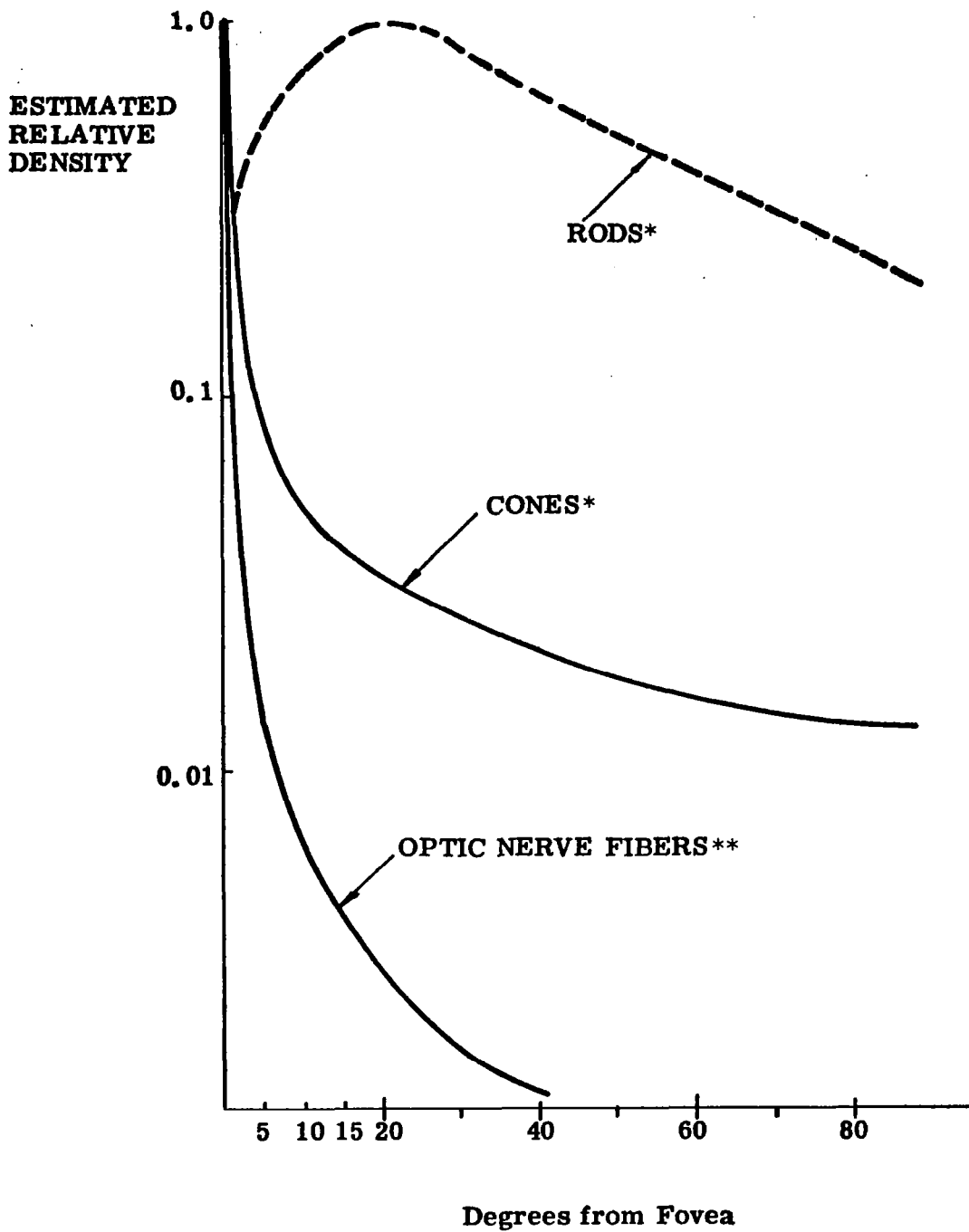

Figure 5.1 ESTIMATED CONE, ROD, AND OPTIC NERVE FIBER DENSITIES OVER THE RETINA

*Taken from standard texts.

**Estimated using (a) fiber density = cone density at fovea, and (b) total of all fibers = 1/7 total of all cones.

1. Perform a real time simulation of the astronaut's oculometrically controlled tracking telescope. This would help determine optimum values for the system parameters and also evaluate how much more visual information the astronaut might derive from this system than from manual control of his telescope.
2. Develop a helmet-mounted version of the oculometer that would be suitable for use by an astronaut in space.
3. Determine a subject's mental frame of reference, under a variety of conditions, as a function of the angular direction of his head and eyes. This would show how, and to what extent, his mental frame of reference could be determined by the oculometer.
4. Evaluate an oculometrically controlled AMU system in a zero g simulator. This work would show the extent to which the oculometer could assist the astronaut in the efficient control of his AMU system.

The measurement applications will require that the oculometer be developed from the present feasibility model to an operational unit. Experimental investigations should be made with the oculometer to define the relationship between mental alertness and eye pointing direction.

SECTION 6
CONCLUSIONS AND RECOMMENDATIONS

6.1 SUMMARY

Automatic acquisition and continuous tracking of the pupil/iris boundary and, simultaneously, of a corneal reflection of a light source fixed in the oculometer have been demonstrated through use of a new electro-optical technique for eye direction measurement requiring no clamping to, or of, the head.

It has been shown that the indicated position of the corneal reflection relative to the center of the pupil is proportional to eye direction.

The random noise level in the indicated eye direction output channel is equivalent to about 0.3 degree over a 1.5 cps bandwidth. The repeatability of the measurements is about 2.0 degrees.* There is nonlinearity and axis crosstalk.

Design refinements are needed to make the acquisition system and automatic pupil amplitude loop fully operational.

*This is due mainly to the relatively large size of the scanning aperture hole (0.020 inch at the eye, corresponding to about 10 degrees of eye rotation). The results show that a smaller hole (e.g., 0.005 inch) should be used and that a more sophisticated technique should be employed to determine, from the ID output, the position of the pupil/iris boundary independently of brightness variations around the iris.

6.2 CONCLUSIONS

The feasibility of the oculometer has been demonstrated. Analysis of the results in relation to the device has led to the following conclusions:

6.2.1 Electronics

1. The 120 cps circular scan tracking system, 720 cps time-division-multiplex, is satisfactory.
2. The acquisition system is basically satisfactory but may be improved by:
 - a. Shaping the raster to the circular contour of the ID tube.
 - b. Operating the raster at a higher frame and line rate.
3. The pupil tracking information should be cut off at the top of the pupil scan to eliminate the effect of a drooping eyelid.
4. The pupil amplitude loop, in its present form, is unsatisfactory. The amplitude modulator should be replaced by a balanced amplitude modulator so that the modulation signal is not injected into the pupil position loop.
5. A means should be found of detecting the exact position of each part of the pupil/iris boundary, independently of the brightness of each part of the iris.

6.2.2 Image Dissector

1. The ID proved to be of acceptable quality (in terms of focus and uniformity) over the entire photocathode.

2. The 0.025 inch diameter aperture is too large. A smaller aperture would reduce the errors due to nonrepeatability.
3. The annular design (0.012 inch wide aperture, 0.080 inch diameter annulus) employed during the first phase was probably better suited for tracking the pupil/iris boundary than the present circular aperture. However, the annular design presents serious problems for automatic acquisition.
4. The ID has an S11 photocathode. This is not the best choice from the point of view of sensitivity, especially when the source of peripheral illumination is a filament lamp. (The S20 surface for the ID was temporarily unavailable at the inception of the Phase II program.)
5. The scan deflection system (coils and drive amplifiers) proved to be entirely satisfactory.
6. The system using an ID suffers from an important disadvantage: the amount of radiation actively contributing to the operation of the system at any instant is only a very small fraction of the total radiation (from the eye illuminator) incident at the eye. The total amount of light that can be used to illuminate the eye is limited by physiological constraints.

An alternative system (Figure 6.1) utilizes the flying spot principle, in which only that part of the eye which is being observed by the detector at any instant is being illuminated. For the same physiological limit on eye illumination, a larger detector signal can be obtained.

6.2.3 Peripheral Eye Illuminator

1. The eye illuminator used was a plastic ring containing three miniature filament lamps (Edmunds Scientific Co. #40.691). At certain positions of the eye, the corneal reflection of the ring overlapped the pupil. This causes a serious disturbance of the pupil tracking loop. Some of the anomalous parts of the traces shown in Section 4 are thought to be associated with such disturbances.

It is desirable, therefore, that an alternative method of peripheral eye illumination be found.

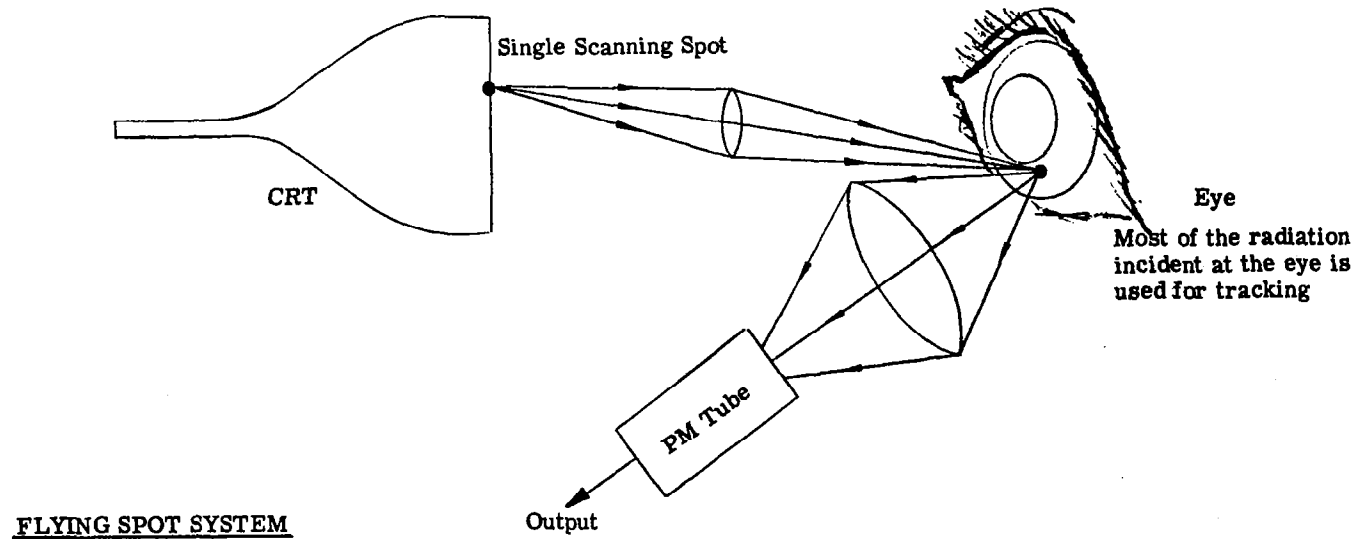
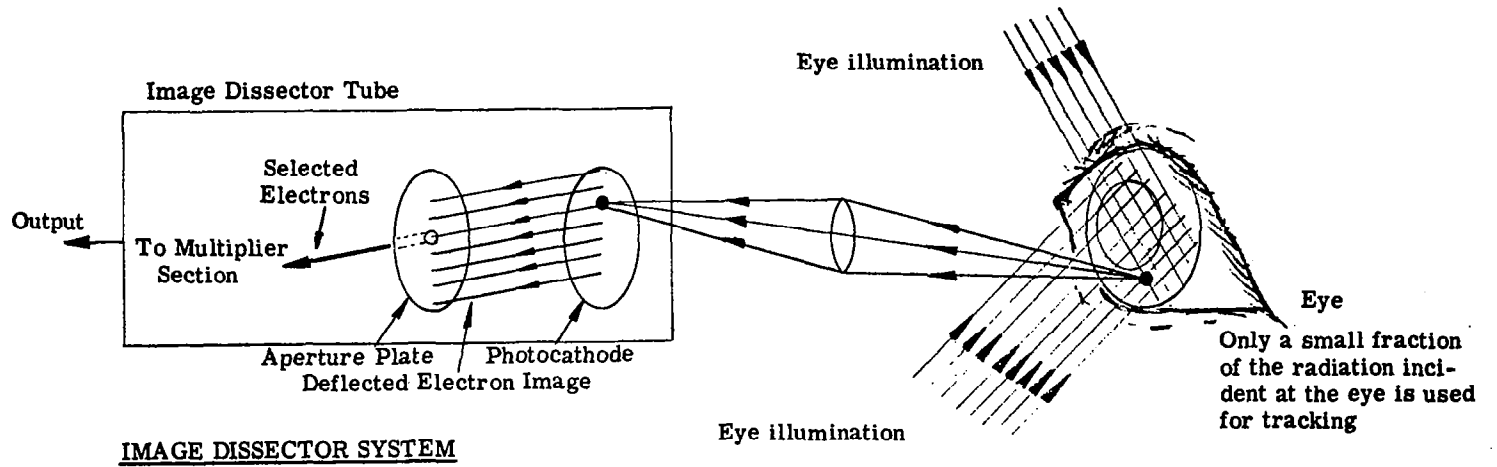

Figure 6.1 COMPARISON OF IMAGE DISSECTOR AND FLYING SPOT SYSTEMS

2. The use of filament lamps in the illuminator is unsatisfactory because:
 - a. They generate a significant amount of heat, which is uncomfortable.
 - b. The illuminating radiation cannot easily be filtered to make it nonvisible.
 - c. The radiation cannot be chopped.

It is concluded that if the illuminator ring is to be used, the light should be ducted to it, by fiber optic bundles (nonimaging) from the light source. In this way a wider selection of light sources will be available, precise filtering will be possible, and the radiation can be chopped if necessary.

6.2.4 Optical System

1. The area of the eye to be imaged onto the photocathode should be larger than a 0.75 inch square. A 1 inch square is recommended.
2. It may be desirable that the ID optical system view the eye from about 10 degrees below the horizontal axis, in order to overcome the effect of drooping eyelashes.
3. The present beam splitter design causes substantial interference with the monocular system. It should be redesigned to move the edges of the beam splitter out of the field of view.

6.3 RECOMMENDATIONS

6.3.1 Conversion to Nonvisible Radiation

The ID tube now being used in the oculometer senses visible radiation reflected from the eye. It is desirable, however, that the sensed radiation be nonvisible--either below the blue end of the visible spectrum or above the red end.

The optimum band of nonvisible radiation for the oculometer depends on the relative reflectance of the human iris at the various wavelengths. Experiments should therefore be made to determine iris reflectance.

Using the results of these experiments, and considering the spectral sensitivity of ID tubes and the spectral radiance of available light sources, a determination can be made of the exact nonvisible radiation to be used in the oculometer.

6.3.2 Optomechanical Redesign

With the present oculometer design, the subject looks through the eyepiece and sees the edges of two beam splitters placed in front of it. These beam splitters and their placement should be modified so that the edges will no longer obstruct the subject's field of view.

The optical system layout should also be modified to improve the visibility of the pupil to the ID tube, by minimizing the effect of eyelashes.

6.3.3 Design of an Improved Eye Illuminator

The method of illuminating the iris should be improved. Probably the eye illumination light source should be located within the oculometer optical system. The eye would then be illuminated by light (nonvisible radiation) coming through the eyepiece. This would replace the plastic ring illuminator now used around the outside of the eyepiece.

6.3.4 Electronic Modifications

Electronic modifications should be directed mainly toward making the oculometer system operate reliably and simply, with minimum adjustment and setup.

In addition, some redesign of the oculometer electronics appears desirable from a purely functional standpoint. Examples of the electronic modifications are:

1. Modification of and/or addition to the automatic acquisition circuitry.
2. Suppression of pupil track information at the top of the circular scan to eliminate the effect of drooping eyelids.
3. An improved method of pupil/iris boundary tracking and automatic pupil scan amplitude (diameter) control.
4. Use of a smaller diameter hole in the ID aperture plate.

APPENDIX A

OCULOMETER APPLICATIONS

1. INTRODUCTION

1.1 Outline

The second phase of this program has included a short study of the possible applications of the oculometer. This Appendix presents the results of that study.

Section 2 lists the applications and describes each briefly. Section 3 considers certain of these applications in more detail. Section 4 is devoted to the particulars of oculometer designs for the various applications.

1.2 General

The oculometer offers, for the first time, the practical possibility of tying the oculomotor apparatus of the eye into the total system in which the man is functioning. None of the previously known methods of eye direction¹ measurement are really suitable for practical use, in this way, outside a laboratory environment.

Because of the prime importance of vision in almost any man/machine situation, and also because of the fundamental role played by the oculomotor system in vision, it is not surprising that many potential oculometric applications exist in man/machine systems. The various applications are presented here not only to show possible specific utilization of the oculometer, but also to illustrate the general possibilities that exist. It is hoped that in this way, new

specific applications may be conceived in relation to specific operational problems as they may arise.

1.3 Equipment and Application Classifications

The oculometer developed to the breadboard stage in the present program is a telescopic oculometer (Figure 3.1). That is, the subject using the oculometer looks through the eyepiece of a low power telescope (monocular) at the viewed scene. In addition to its normal telescopic function, the eyepiece is used to image the pupil area of the eye onto the photocathode of an image dissector tube and also to direct onto the eye the light which forms a point corneal reflection within the pupil.

The telescopic oculometer may be considered a fixed, bench- or rack-mounted unit, suitable for use when the subject must view indirectly through an optical system, as distinct from naked eye vision.

Another configuration is the head- (or helmet-) mounted oculometer (Figure A. 1). The subject is allowed normal, naked eye vision, with free movement of the head. A head-mounted dichroic beam splitter in front of the eye transmits light to the eye over the visible spectrum. This beam splitter also reflects light that is outside the visible spectrum (but is within the operating spectrum of the oculometer) from the eye onto the electro-optical sensing unit mounted on the head (or helmet).

The applications of the oculometer may be divided into two broad classes: control applications and measurement applications. In the control applications, the output signals from the oculometer are used to exert some control effect on the visual scene or stimulus being presented to the subject. There

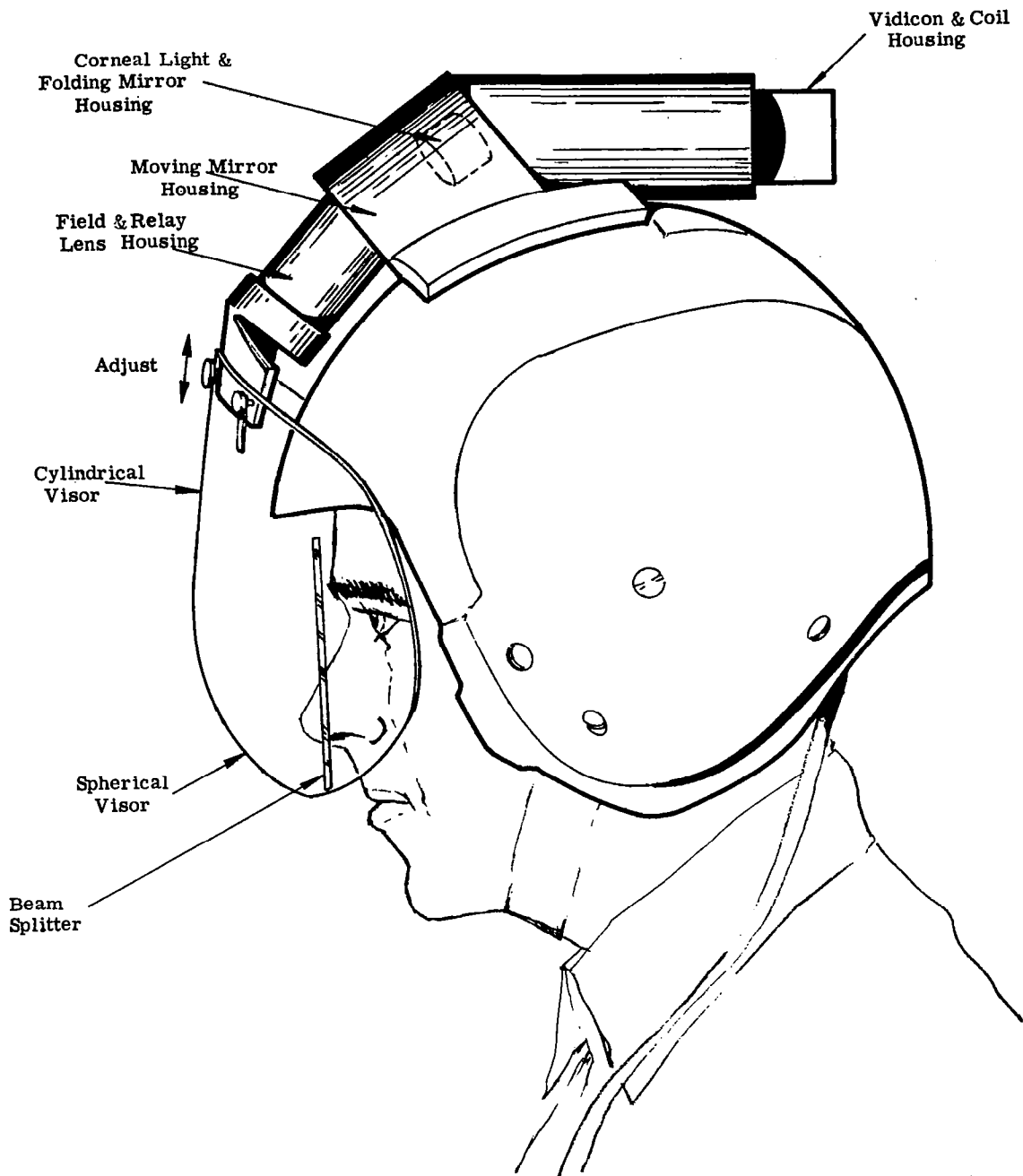

Figure A. 1 CONFIGURATION OF HELMET-MOUNTED OCULOMETER

is a closed loop of information flux from the viewed scene to the eye, to the oculometer, and back to the viewed scene via the oculometric control action. In measurement applications, the oculometer output information is simply recorded or otherwise utilized in an open loop manner.

2. LIST OF APPLICATIONS

2.1 Visual Search and Tracking

These applications relate particularly to situations where the subject must examine a visual field which is very much larger than the visual field of the eye (2π steradians). For example, an astronaut observing the earth from orbit with a 40X viewer having a field of view of 1 steradian at the eye can slew the viewer to see an area of the earth's surface subtending at least 1600 (40^2) steradians at his eye.

2.1.1 Telescope Pointing Control

The field of view of a telescope is generally smaller than that of the area to which it may be directed. Thus, the optical axis of the telescope must usually be moved in either a search or a tracking task.

When this motion of the telescope axis is relatively slow (e. g. , less than a few degrees/sec), manual (i. e. , hand activated) control can be quite adequate. For high speed search and tracking, however, eye control may be advantageous.

As a general rule, the telescope should be so pointed (whether by hand or eye) as to bring the detail of interest to the center of the field of view. With eye control, this can be accomplished by measuring the angle (θ) between

the eye and the telescope axis. The telescope direction is then altered so as to drive θ to zero. In this way, the subject controls the telescope with no conscious effort beyond that involved in normal vision.

The visual effect would be that whatever detail the eye might then look at would move automatically to the center of the screen within about 2-3 seconds.

Some kind of manual control should be retained--for example, to choose between automatic (oculometric) or manual tracking and also to select tracking response speed.

2. 1. 2 Telescope Zoom Control

In general, the degree of zoom (magnification) of a telescope should correspond to the visual task being performed. Thus low magnification should be used in a search operation, because a wide field of view is provided. High power should be used for identification and tracking, because the maximum possible amount of information from one specific target detail is required.

The type of visual task being performed at any time can be determined by measuring eye direction with an oculometer. In a search task, the axis of the eye will be moving over relatively large angles and at relatively high rates. In an identification or tracking task, the velocity and amplitude of eye motion will be significantly less. The output of the oculometer can therefore be analyzed to determine the type of visual task being performed, and the appropriate degree of zoom can then be commanded automatically:

low magnification for large amplitude and velocity eye motion (search task)

high magnification for low amplitude and velocity eye motion (identification or tracking task)

Again, manual control will be retained to select automatic or manual zoom control, rate of zoom changes, etc.

2. 1. 3 Image Stabilization

In order to view a moving target with maximum clarity, it must be stabilized on the retina (over the fovea) by the voluntary action of the oculomotor system of the eye. * If a target is moving or vibrating rapidly, the eye cannot move fast enough to stabilize the image perfectly on the retina. If, however, eye direction is measured as the eye attempts to follow the target, the image can be automatically moved (as in an oculometrically controlled tracking telescope system, Section 2. 1. 1) so as to reduce the apparent target motion and hence improve the degree of image stabilization on the retina. Observation of rapidly moving or vibrating targets may thus be improved--with oculometric control assisting the eye somewhat as power steering assists the hand in controlling an automobile.

2. 1. 4 Analysis of Photographic Data (Photo Interpretation)

When large quantities of photographic data must be screened (analyzed) by a human subject, the oculometer can be used to automate the process, thereby substantially increasing the amount of data that can be reliably screened in a given time:

*If the target is to be seen, it must not be stabilized against the involuntary motion of the eye.

- a. The motion of the film through the viewer can be controlled either totally or partly by the eye. The system would be similar to that involved in the tracking telescope (Section 2. 1. 1), except that the axis of the viewer would be kept fixed and the viewed scene (i. e. , the film) moved by eye control.
- b. The magnification of the film viewer can be controlled automatically to correspond to the visual task being performed (a system similar to that described in Section 2. 1. 2).
- c. Prescreening the film data (e. g. , by automatic image processing devices) can define areas of potential or special interest. Measurements of the subject's eye direction as he views the film can be used to check whether he has adequately surveyed these areas.
- d. The oculometer can be used to read out position coordinates of target details. Whenever the operator wishes to identify a specific detail, he pushes a momentary contact button as he looks at this detail. The oculometer output is recorded at that instant, thereby defining the coordinates.

2. 1. 5 Microscopic Examination of Relatively Large Areas

The area of a specimen on a microscope slide may be very many times that of the field of view of the microscope. If the specimen is homogeneous there is obviously no particular problem in positioning the slide under the microscope. However, if small, specific regions must be located, a search task must be performed.

As described in Sections 2.1.1 and 2.1.2, the search and identification tasks can be automated with the use of the oculometer. The real (or apparent) motion of the specimen would be so controlled by the oculometer output as to ensure that whatever the subject was looking at, at any time, would be brought to the center of his field of view. The magnification of the microscope would be controlled according to the nature of the visual task being performed, as revealed by the magnitude and velocity of the subject's eye motion:

- low power for search
- high power for identification

Some manual control should be retained.

2.2 Astronaut Maneuvering Unit

An astronaut maneuvering unit (AMU) consists of a reaction jet propulsion system and control unit, with which the astronaut can command translational and rotational motion.

In general the control unit will have six command input channels, corresponding to the six degrees of freedom of the free-floating astronaut. An important design problem is the means by which the astronaut will communicate these commands to the AMU system. Hand action (e. g., control wheel and/or control stick) is undesirable, because the astronaut must have his hands free for other purposes--to operate equipment, to handle tools, etc. Some other muscular system of the body must therefore be found. With the

development of a practical head- or helmet-mounted oculometer, the eye is a possible medium for transferring at least some of the astronaut's maneuver commands to the AMU.

As discussed later, eye control or partial eye control of an AMU not only offers the advantage of hands-free operation but also simplifies the problem of axis transformation. The frame of reference in the astronaut's mind is in terms of "left-right," "up-down," and "in-out" translation, and roll, pitch, and yaw rotation. These vectors correspond to the axes of the AMU propulsion unit only when the head is in a normal position with the eyes looking straight ahead. The transformation from the astronaut's mental axes to the propulsion unit axes requires knowledge of the eye (and possibly head) direction relative to the AMU axes. Unless this transformation is performed automatically (implying continuous measurement of eye direction), the astronaut will have an added mental task of converting commands from his "own" axes to those of the AMU propulsion unit. He will also have to supply three, rather than one, correctly proportioned command inputs to the AMU system.

2.3 Air Traffic Control

An operator looking at a radar display showing several aircraft "blips" at the same time may wish to designate a particular aircraft. To do so he may place a "light pen" over the blip of interest. This function could be performed automatically, however, by measuring the eye pointing direction of the operator. He would need simply to look at a blip and push a button. The use of eye control in this way might reduce his work load and increase his efficiency and speed.

2.4 Laser Communication

Laser beams can be used to transmit signal (e. g. , speech) information.

Many of the potential advantages of laser communication derive from the extreme narrowness of the beam, but this may also make it difficult to point the beam in the desired direction. Conventional manual action would suffice in a static situation but not in a dynamic situation. For example, it might be difficult to point a laser communicator manually either when moving about on earth or while space walking. A possible solution is to arrange that the laser beam is always turned in the same direction as the eye, so that the operator can communicate to a point simply by looking at it. This natural action is compatible with the line-of-sight restriction on laser communication.

2.5 Information Retrieval

The library of the future is expected to make extensive use of electronic methods of information storage. Moreover, the volume of available information on any given subject is continually increasing. Hence new techniques for information retrieval may be required.

Someone seeking information may interrogate a library with a classification code that defines his subject matter and may yet be presented with more information than is really useful--so much more, in fact, that selecting from it constitutes a serious bottleneck in the information retrieval system.

In an oculometric system, a list of titles of books or articles would be displayed on a screen. Measuring the user's eye direction would define to the system the specific title at which he was looking. The user could then push a button (or give some other simple signal) to cause the system to display more detailed information about the title--for example, single-sentence summaries of the several parts of an article. A second measurement of eye pointing direction would define the summary of interest and make still more detailed information available.

Eye motion plays a key role in the natural process of high volume information scanning, leading to selection of specific detail. For example, a man can very rapidly scan millions of bits of information in a newspaper to locate an item of interest. In the application of oculometry suggested here, this natural action of the eye is extended and integrated into the operation of the library system.

2.6 Quality Control Inspection

In certain factory operations, an operator must visually inspect many items passing before him on a conveyor belt. His task may be to designate defects or potential defects. The use of the eye for this task might prove to be significantly faster than that of conventional hand action.

2.7 Television--Remote Vision

Television systems are used to view a remote environment (i. e. , they provide remote vision). They can be far more efficient (i. e. , furnish greater visual effectiveness per video bandwidth) if they are designed to match the eye. The resolution of the eye is very nonuniform over the visual field. It

is highest in one very small region (fovea) and falls off rapidly at the periphery. If the resolution of the television system is matched, at all points over the visual field, to that of the eye (i. e., the television resolution is made variable over the field of view), the total sensory requirements of the eye can be met with a much lower video bandwidth than would otherwise be possible.

The oculometer can be a part of such a television system. It will measure the direction of pointing of the eye as it views the television monitor display. This direction information will command the pointing of the camera and, in one system concept, also the position of the display relative to the eye.

2.8 Remote Handling Equipment

Remote handling equipment may be very large (e. g., for work on nuclear propulsion units)--or very small (e. g., for chemical analysis of radioactive material). The operator views the work area and the remote manipulators, and by hand action commands the manipulators to move. Conceivably, these commands could be generated, in part, by the operator's eye. The magnitude and direction of any desired "robot" motion would usually be correlated strongly with the present position or recent displacement of the operator's eye.

The absence of range information in the oculometer output appears as a disadvantage in this application, since defining a three-dimensional position or displacement vector generally requires such information. However, other techniques could be used in association with the oculometer to determine range.

2.9 Measurement (Noncontrol) Applications

2.9.1 Mental Alertness Monitor

The term "mental alertness" may be associated with a "psychophysiological dimension, indicative of how 'wide awake,' alert, or excited an organism is at a particular time."² The words "activation" or "arousal" are also used to refer to this psychophysiological dimension.

There is reason to believe that the degree of mental alertness of a subject may be related to the nature of his eye movements. Eye movements are involved very directly in the prime information channel into the brain (vision). It is very probable, therefore, that the amount of visual information that a subject is receiving, or desires to receive, will be reflected in his eye movement patterns. The amount of sensory information that a subject is processing, or wishes to process, is a numerical quantity (bits or bits/sec) which may be assumed to correspond to the qualitative psychological concept of "alertness" (arousal, activation). Thus, information concerning the state of mental alertness of a subject could be continuously obtained by measuring (and analyzing) his eye pointing direction.

2.9.2 Reading Analysis

A convenient method of eye direction measurement may find application in studies of:

- a. the normal reading process
- b. abnormal reading, particularly in those children who have difficulty in learning to read

- c. speed reading techniques
- d. new methods of teaching reading

2.9.3 Study of the Early Development of Oculomotor System

The development of the oculomotor system from birth through the first few months of life is of particular interest. For this application the eye direction measuring technique must be such as to disturb the subject in the least possible manner. The eye direction of an infant would have to be measured continuously while he was resting and unexcited.

2.9.4 Psychological Testing

The continuous measurement of a subject's fixation point as he views test images might be useful in psychological testing--e. g. ,

- a. to determine images or patterns that the gaze tends to avoid
- b. to determine images or patterns that the gaze tends to seek out
- c. to determine the correlation between audio information input to a subject and his consequent fixation point

Specific areas of possible application include:

- a. interrogation of subjects who may not be entirely truthful
- b. analysis of the effectiveness of advertising displays
- c. psychiatric diagnosis

2.9.5 Pilot Training and Evaluation

Continuous measurement of eye pointing direction might be useful in the training and evaluation of pilots. For example, a pilot might be presented with a given flight situation on a simulator, and the correct flight procedure would call for a periodic check of certain instruments in a prescribed sequence correlated with the various flight events. A continuous measurement of the pilot's eye pointing direction would show exactly where he was looking throughout the simulation. Thus his understanding of the procedures required could be evaluated.

3. APPLICATION ANALYSIS

3.1 Visual Search and Tracking

The following paragraphs discuss a specific application--an astronaut's tracking telescope--and present a general mathematical analysis relevant to any application within this class.

3.1.1 Astronaut's Tracking Telescope

Recent manned space flights have shown that detailed observation of the earth's surface is potentially one of the most useful tasks that an astronaut can perform in orbit.* Remarkably clear, wide-angle views of large areas

*High-resolution observation of the moon (or a planet) by astronauts in orbit around it will be important for surveying and also for selection of a landing site. Accurate visual tracking of the surface is a possible terminal guidance technique for lunar or planetary landings.

of the surface can be obtained in a way never before possible. It appears* that detail as small as 20 feet at the surface can be seen.

This figure (20 feet) for the limiting resolution from earth orbit is consistent with analytical and experimental measures of the ultimate resolution (due to atmospheric turbulence) of earth-based astronomical telescopes. In Reference 3 the half width of stellar images is quoted as 6 seconds of arc. Translating this to viewing the earth from a 100 mile high orbit, the resolution half width is about 16 feet. But since atmospheric turbulence may be less serious when the earth is viewed from orbit than when astronomical observations are made from the earth, the ultimate limit on resolution in orbital viewing of the earth may be significantly less than 16 feet.

In any case, the absolute limit on resolution means that the magnification of the astronaut's telescope cannot, usefully, be made indefinitely high. The basic acuity (resolution) of the human eye is about 1 minute of arc. It would be reasonable, therefore, to set as an upper limit of telescope magnification that value which made the smallest resolvable detail on the ground (as limited by atmospheric turbulence) subtend an angle of 3 minutes of arc at the eye. Under these conditions (of maximum magnification) the image would appear "grainy" but not excessively so.

The following table gives the value of this maximum magnification for various resolution limits in reference to a 100 mile high earth orbit.

*For example, from published photographs taken in orbit.

<u>Resolution Limit at Ground Due to At- mospheric Turbulence (ft)</u>	<u>Maximum Useful Magnification of Astronaut's Telescope (X)</u>	<u>Field of View On Ground (miles)</u>	<u>Velocity of Image at Eye Due to Orbital Velocity (°/sec)</u>
1	461	0.217	1300
5	92.2	1.09	260
10	46.1	2.17	130
20	23.1	4.34	65
50	9.22	10.9	26
100	4.61	21.7	13

In order to see surface detail at the highest possible resolution (as limited by atmospheric turbulence), the astronaut will thus require an optical magnification of at least 20X and possibly 40X or higher.

In reality, an astronaut would find it very difficult to use a telescope (to view the ground) that had sufficient magnification (i. e. , 20X - 40X) to exploit the potential for satellite observation of the earth. The specific problems inherent in the use of this much magnification are discussed below.

1. In viewing a point of detail, the telescope should be highly stabilized and pointed to an accuracy of about 1/3 degree, with angular motion less than about 1/30 degree/second. (The line of sight to the ground will rotate about 3 degrees per second, because of orbital motion and the tumbling of the spacecraft.)

2. Because of the small area of the ground covered at high magnification (and also because of the rapid relative motion of the ground, due to orbital velocity), the astronaut will frequently wish to repoint the telescope.

3. Because of the very small field of view at high magnification, the astronaut must use a much lower power for initial orientation, recognition, and acquisition of ground areas of interest. In order to avoid loss of acquisition in the relatively short time* available for viewing, some zoom action will be needed to transfer from the acquisition mode to track. Frequently the astronaut will wish to zoom in and out rapidly in order to get more resolution for identifying certain distinguishing features while in the acquisition mode. Thus the zoom action is a very important part of an effective telescope system.

These control problems of the astronaut's telescopic earth viewer indicate that oculometry might be applied to yield much higher operational performance (Figure A. 2).

In oculometric pointing control, the direction of the telescope axis will be controlled so as to bring a detail to the center of the field of view. Since the telescope pointing control will not, generally, be required to yield

*At an orbital speed of 5 miles/sec, only about 20-30 seconds will generally be available for clear vision of a point on the ground.

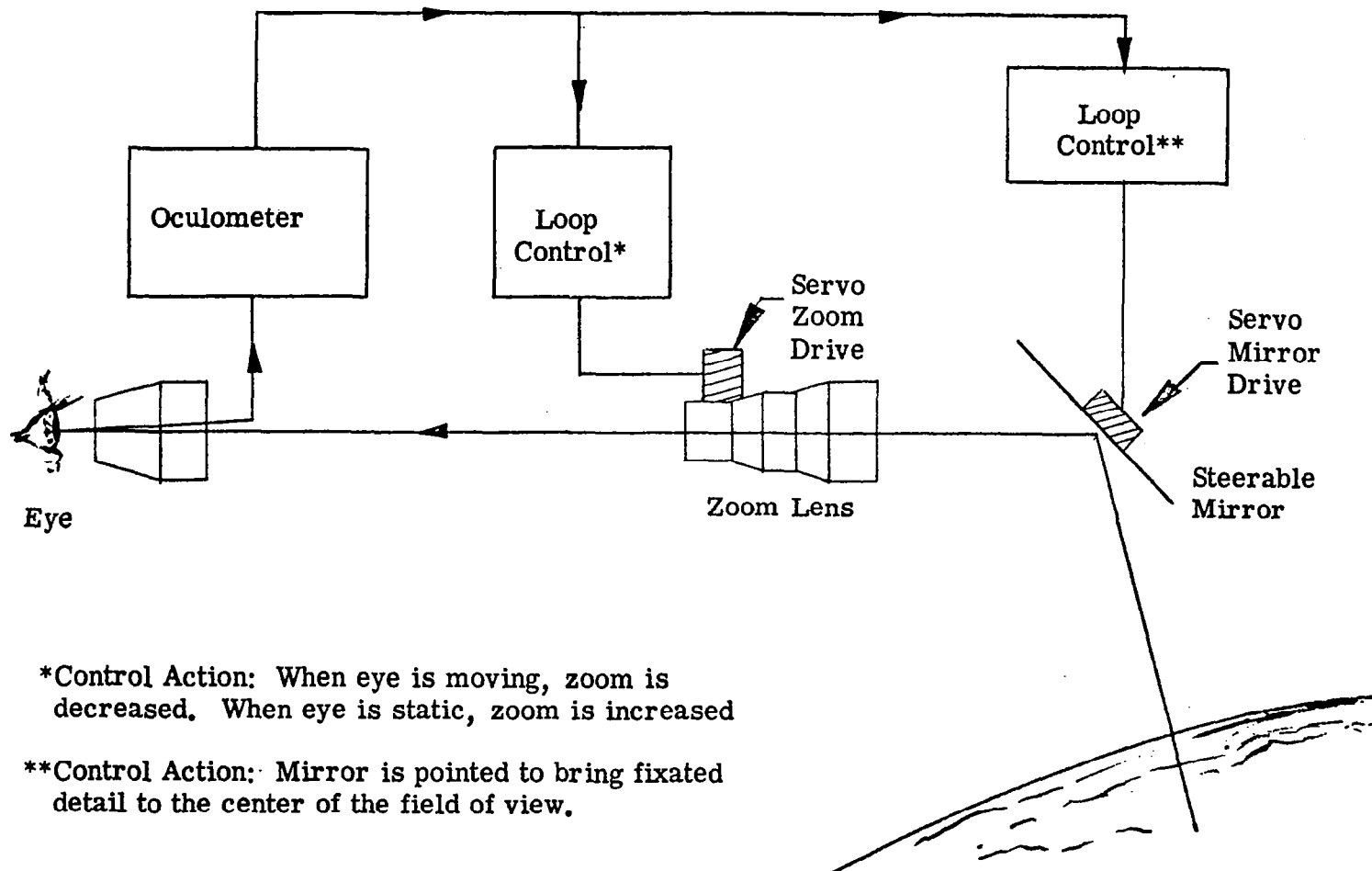

Figure A.2 ASTRONAUT'S EYE-CONTROLLED TRACKING TELESCOPE

accurate position information,* but will be employed only as a convenience for the astronaut, the dynamic tracking performance of the control loop will not be critical. For example, it may be convenient to choose the loop gain so that detail at the edge of the field will be brought to the center, by oculometric control, in two seconds. In short, smooth control of magnification and pointing will provide the maximum visual effectiveness for the astronaut.

In the oculometric zoom control, the magnitude of his eye motion is measured and this signal is used to control the degree of zoom. If his eyes move over the ± 30 degree field of view in a searching pattern, he obviously does not require any increase in power. As soon as he spots a detail of interest, however, his eye motion will cease, because he will be looking steadily at this detail. At this time he will require more magnification, and this can be automatically triggered through the sensing of the reduced eye motion. Typically, the automatic zoom action might double the magnification every second, so that in just less than five seconds full magnification would be built up. If, as the magnification increased, the astronaut was able to recognize the detail he was looking at, he might then turn his eyes away from it and start searching for other detail of interest. This eye motion would be made to reverse the zoom action.

*For certain applications, however, it might be very useful to have an accurate readout of the astronaut's viewing direction (e. g. , in order to point other spacecraft systems at the same detail). This information might be obtained by adding the oculometer output signals to the telescope pointing direction signals.

In summary, the telescope would incorporate a servo control loop which would automatically keep the magnification at whatever value necessary to cause a ± 10 degree motion of the astronaut's eyes. In a search mode at 2X magnification, this ± 10 degrees would cover 20 miles on the ground. In the track mode at 40X magnification, the ± 10 degrees would cover 1 mile on the ground.

3.1.2 Mathematical Analysis of an Oculometrically Controlled Tracking Telescope (Viewer)

The unique characteristics of an oculometrically controlled viewing device (OCVD) are that

1. whatever detail the operator might choose to look at would be brought to the center of the field of view.
2. the magnification would be automatically adjusted to suit the visual task being performed.

The purpose of this analysis is to investigate, in a simple and approximate manner, this unusual closed loop feedback control system.

The OCVD is illustrated in Figure A.3. In essence the design problem is to determine the form of the function $F(p)$ (feedback transfer function) that will give stable and tight control under operational conditions.

3.1.2.1 Design Problem

The general form of $F(p)$ may be taken as

$$F(p) = \frac{\alpha}{p} + \frac{\beta}{p^2}$$

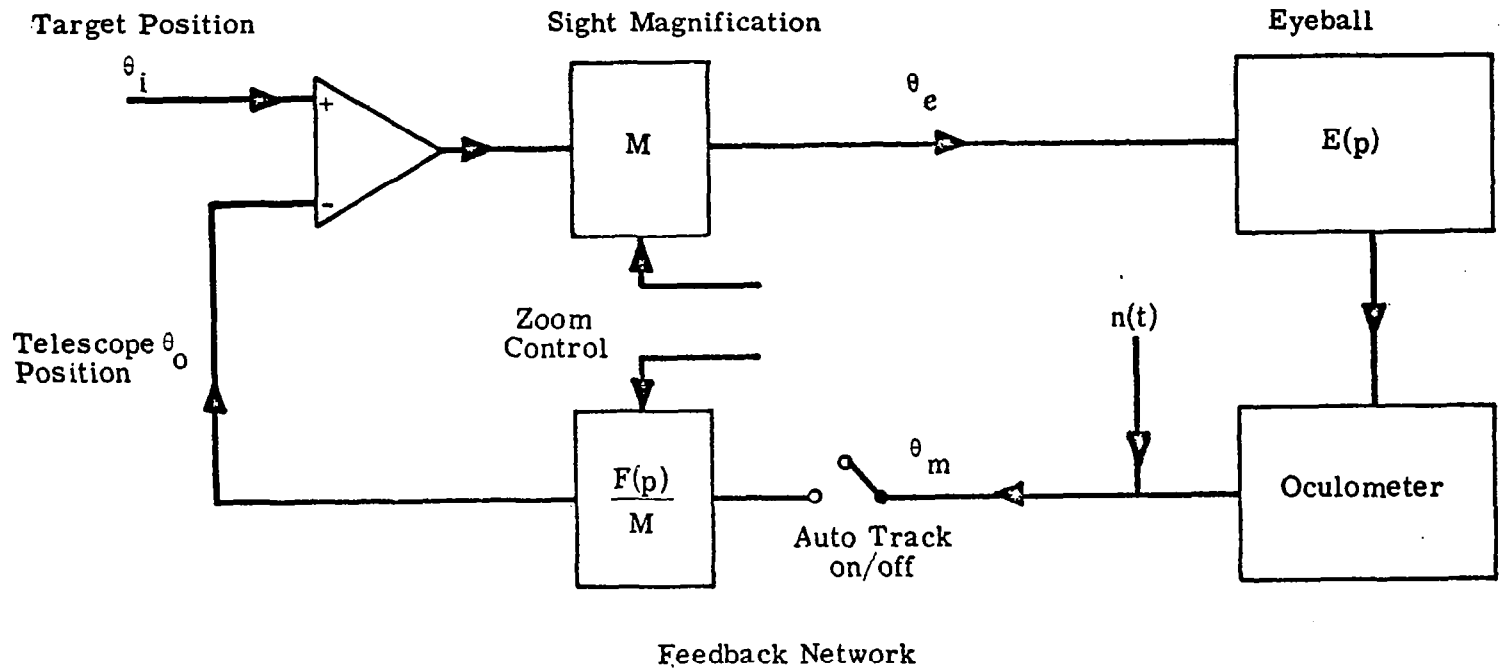

A-22

$$\begin{aligned} \theta_e &= M(\theta_i - \theta_o) \\ \theta_m &= \theta_e E(p) + n(t) \\ \theta_o &= \theta_m \frac{F(p)}{M} \\ \theta_o &= \frac{EF}{1+EF} \theta_i + \left(\frac{n}{m}\right) \frac{F}{1+EF} \\ \theta_e &= \frac{M\theta_i}{1+EF} + \frac{nF}{1+EF} \end{aligned}$$

Figure A.3 OCVD SYSTEM SCHEMATIC

The exact design of $F(p)$ depends on the form of the transfer function of the eye $E(p)$; essentially, the poles of $1/1 + EF$ must be kept within the stable, left-hand side of the complex plane. The exact nature of $E(p)$ is not known, especially at the range of frequencies where its effect on $1/1 + EF$ is most pronounced. In important respects $E(p)$ may be subject to variations, because it is a physiological function. Therefore, $F(p)$ can be exactly designed only by experimentation, i. e., trial of various functions $F(p)$ in an actual working OCVD loop. (Even if $E(p)$ were known, it might still be better to design $F(p)$ by experiment, because the mathematical analysis involved would be so complex.)

However, a simple analysis can be undertaken by assuming that $E(p) = 1$ -- i. e., by assuming perfect eyeball dynamics. From Equation 3 in Section 3.1.2.2 below, neglecting noise, the target angle, θ_e , presented to the eye, is given by

$$\theta_e = \frac{M}{1 + EF} \theta_i$$

Assuming that $E = 1$ and $F = \frac{\alpha}{p} + \frac{\beta}{p^2}$,

$$\theta_e = Mp^2 \left(\frac{1}{p^2 + \alpha p + \beta} \right) \theta_i$$

The choice of values of α and β determines the nature of the response.

$$\text{Let } \beta = \omega_0^2$$

$$\text{and } \alpha = 2 \zeta \omega_0$$

Then ζ is the damping factor of the response and ω_0 the cutoff frequency in radians/sec. By restricting ω_0 to a value sufficiently below the cutoff frequency of $E(p)$, the assumption $E(p) \equiv 1$ will become reasonable. At frequencies where this assumption begins to break down, the loop gain [determined by $F(p)$] will be sufficiently low (if ω_0 is small enough) to ensure stability. Thus the results derived by assuming $E(p) \equiv 1$ will be valid for low values of the constant ω_0 . The theoretical performance of the OCVD will, however, be improved by increasing ω_0 , but if ω_0 is chosen too near the break frequency of $E(p)$, the approximation $E(p) \equiv 1$ will break down and other effects will occur to degrade OCVD system performance. There will be an optimum choice for ω_0 , to be determined by actual experiment.

The damping factor ζ will be chosen, here, to yield an optimum transient response, i. e.,

$$\zeta = \frac{1}{\sqrt{2}}$$

Thus

$$\theta_e = Mp^2 \left(\frac{1}{p^2 + \sqrt{2} p \omega_0 + \omega_0^2} \right) \theta_i$$

Three inputs of interest are:

$$L(M \theta_i) = \psi_1/p^2 \text{ a step of } \psi_1^0$$

$$L(M \theta_i) = \psi_2/p^2 \text{ a ramp of } \psi_2^0/\text{sec}$$

$$L(M \theta_i) = \psi_3/p^3 \text{ an accelerating ramp of } \psi_3^0/\text{sec}^2$$

It is shown later that the responses θ_{e_1} , θ_{e_2} , θ_{e_3} to these three inputs are:

$$\theta_{e_1} = \psi_1 \sqrt{2} e^{-\frac{\omega_0 t}{\sqrt{2}}} \cos \left(\frac{\omega_0 t}{\sqrt{2}} + \frac{\pi}{4} \right)$$

$$\theta_{e_2} = \psi_2 \frac{\sqrt{2}}{\omega_0} e^{-\frac{\omega_0 t}{\sqrt{2}}} \sin \left(\frac{\omega_0 t}{\sqrt{2}} \right)$$

$$\theta_{e_3} = \frac{\psi_3}{\omega_0} \left[1 - \sqrt{2} e^{-\frac{\omega_0 t}{\sqrt{2}}} \sin \left(\frac{\omega_0 t}{\sqrt{2}} + \frac{\pi}{4} \right) \right]$$

These transient responses are sketched in Figures A. 4, A. 5, and A. 6.

As discussed later, a value of f_0 ($\omega_0/2\pi$) of 0.25 cps would appear to be a safe estimate in view of published data on the form of E(p). The transient time constant of the system would then be

$$\frac{\sqrt{2}}{\omega_0} = \frac{2\sqrt{2}}{\pi} \approx 0.9 \text{ second}$$

An exponential increase in magnification with this time constant would thus be reasonable (i. e., $M = 1$, $t = 0$; $M = 3$ at $t = 1$; $M = 9$ at $t = 2$; $M = 27$ at $t = 3$).

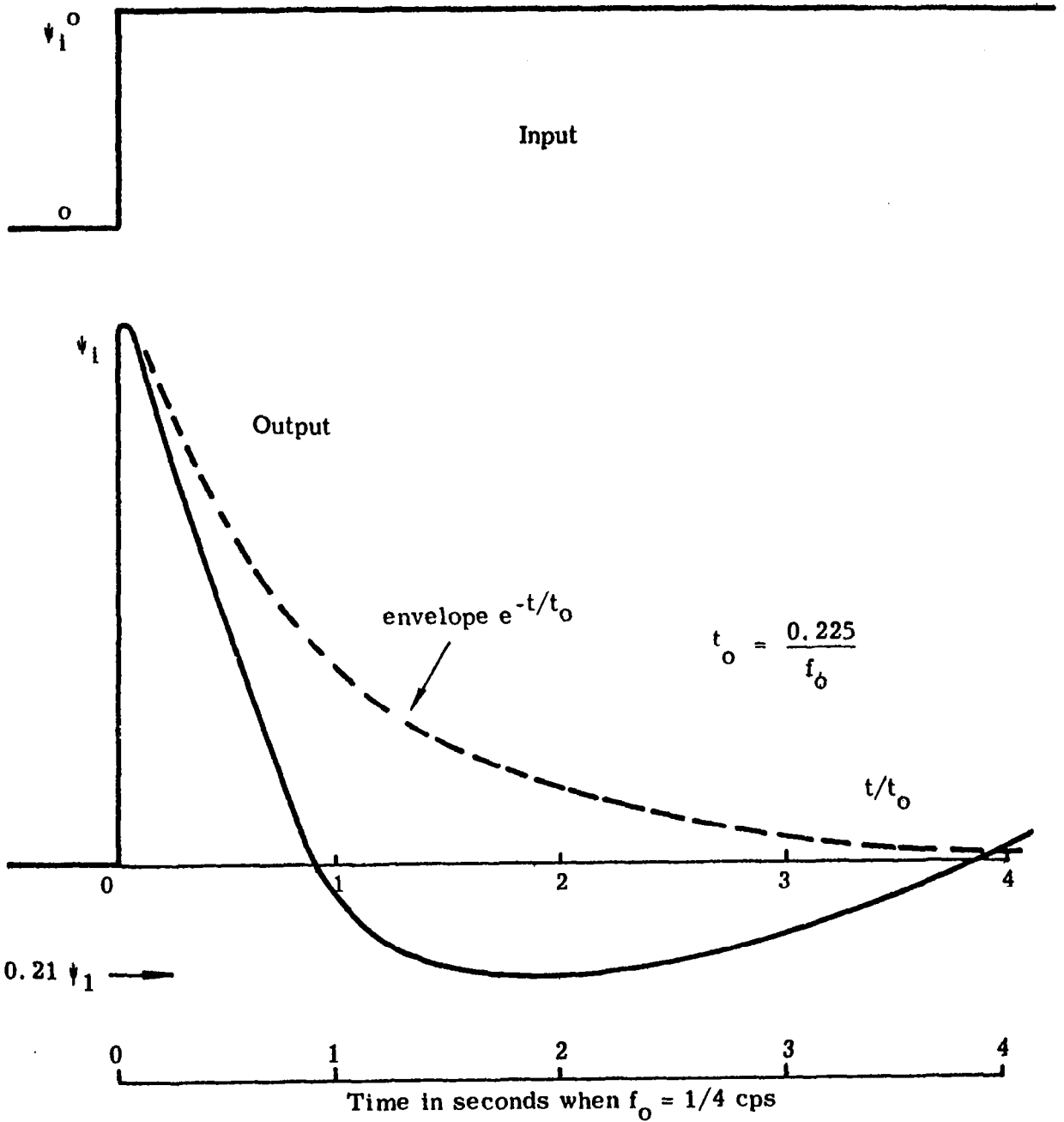

Figure A.4 RESPONSE TO A STEP INPUT

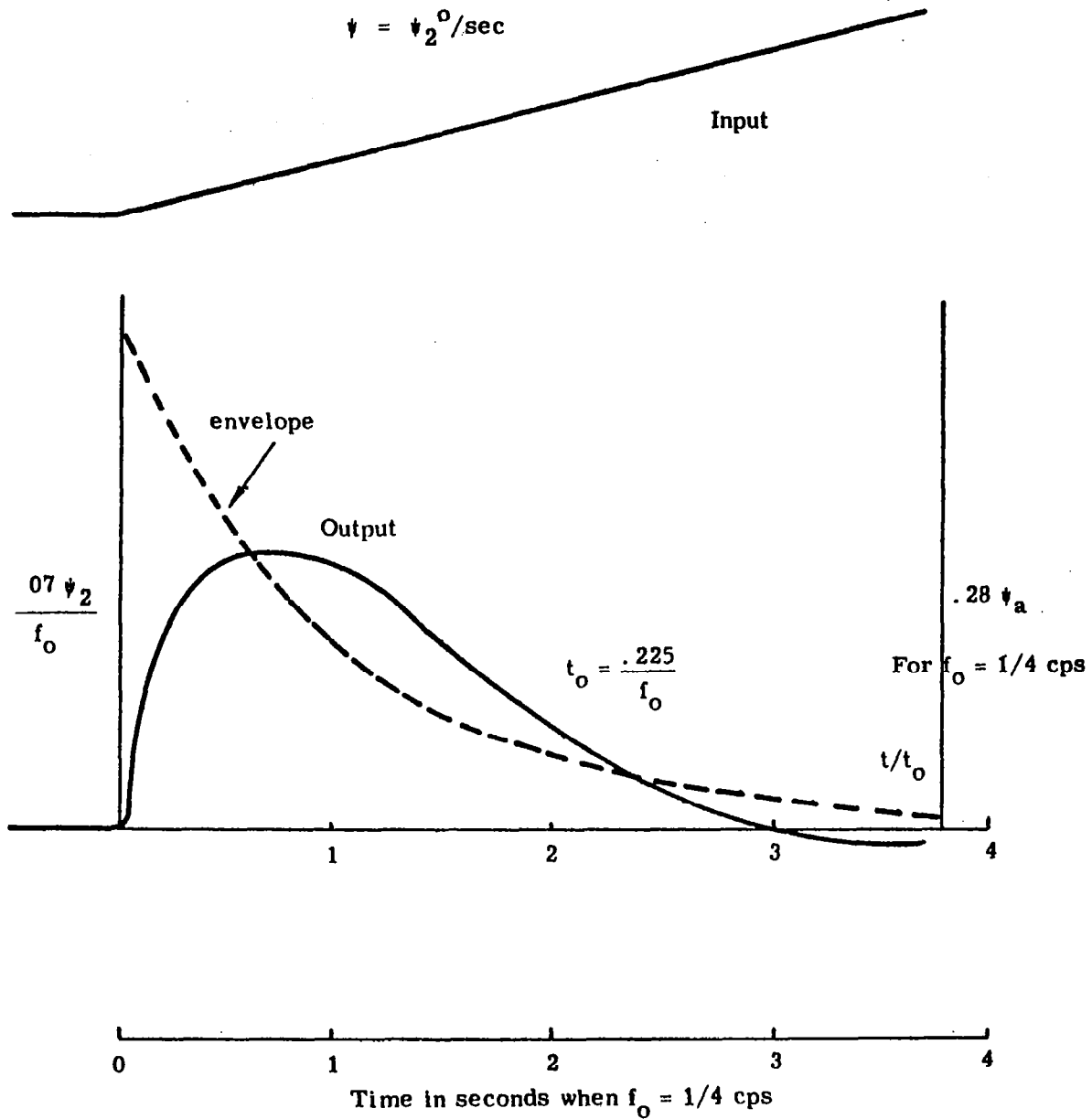

Figure A.5 RESPONSE TO A RAMP INPUT

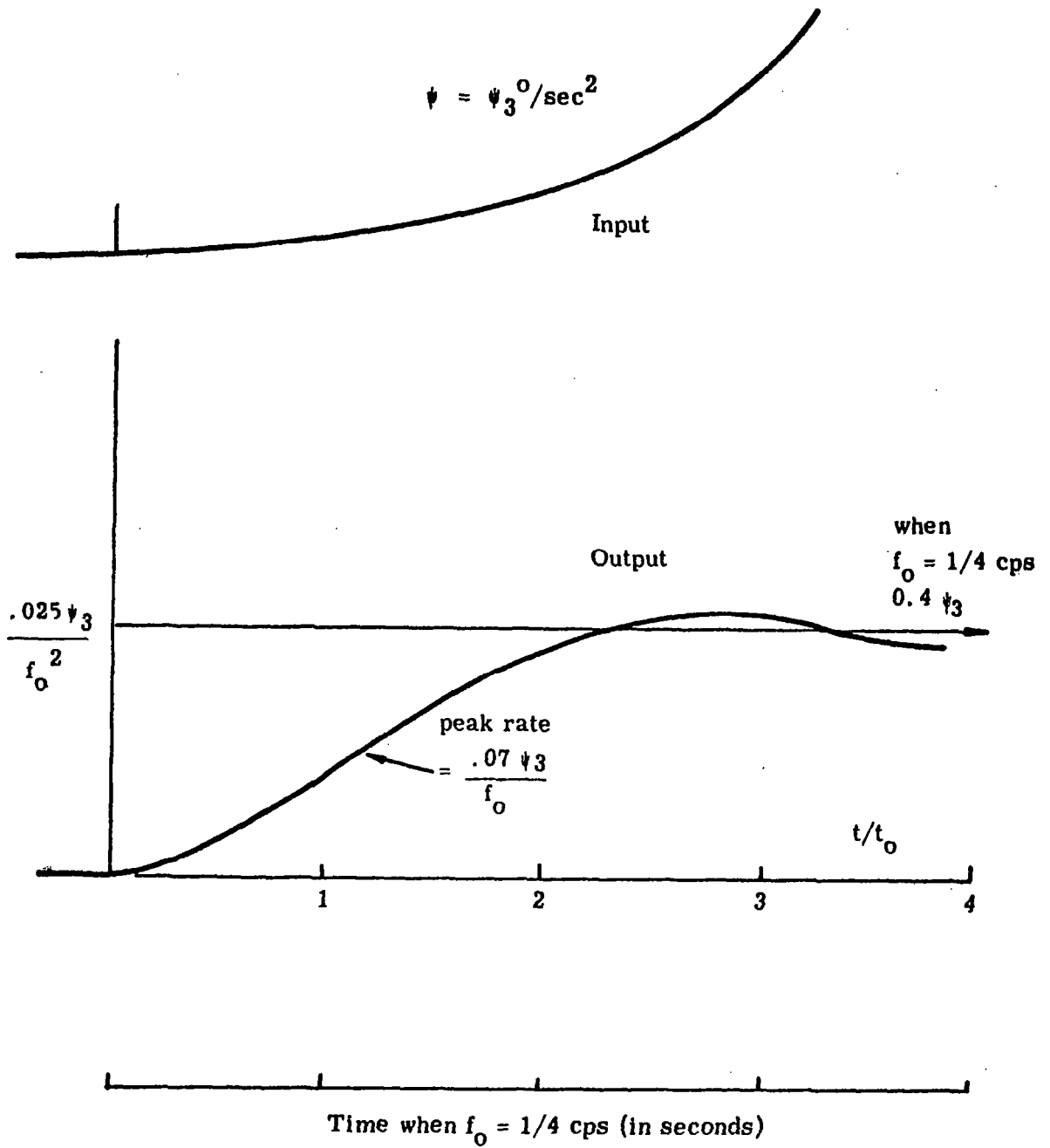

Figure A.6 RESPONSE TO AN ACCELERATING RAMP INPUT

3.1.2.2 Feedback Loop Analysis

In reference to Figures A.3 and A.7, θ_i is the target position (direction) and θ_o the telescope direction, both relative to the mounting frame of the OCVD. The telescope magnification is M . The oculometer measures eye direction (θ_e) as θ_M , where

$$\theta_M = \theta_e E(p) + n$$

and where n is the combined error noise of the eye and oculometer. The signal θ_M is used to control telescope position through the network $F(p)/M$. It can be seen from Figure A.3 that the telescope direction θ_o is given by

$$\theta_o = \frac{EF}{1+EF} \theta_i + \frac{n}{M} \frac{F}{1+EF} \quad (1)$$

The best estimate of target position is given by

$$\theta = \theta_o + \frac{\theta_M}{M}$$

i. e. ,

$$\theta = \frac{E(1+F)}{1+EF} \theta_i + \frac{1+F}{1+EF} \frac{n}{M}$$

The error in target position is

$$\delta\theta = \theta - \theta_i$$

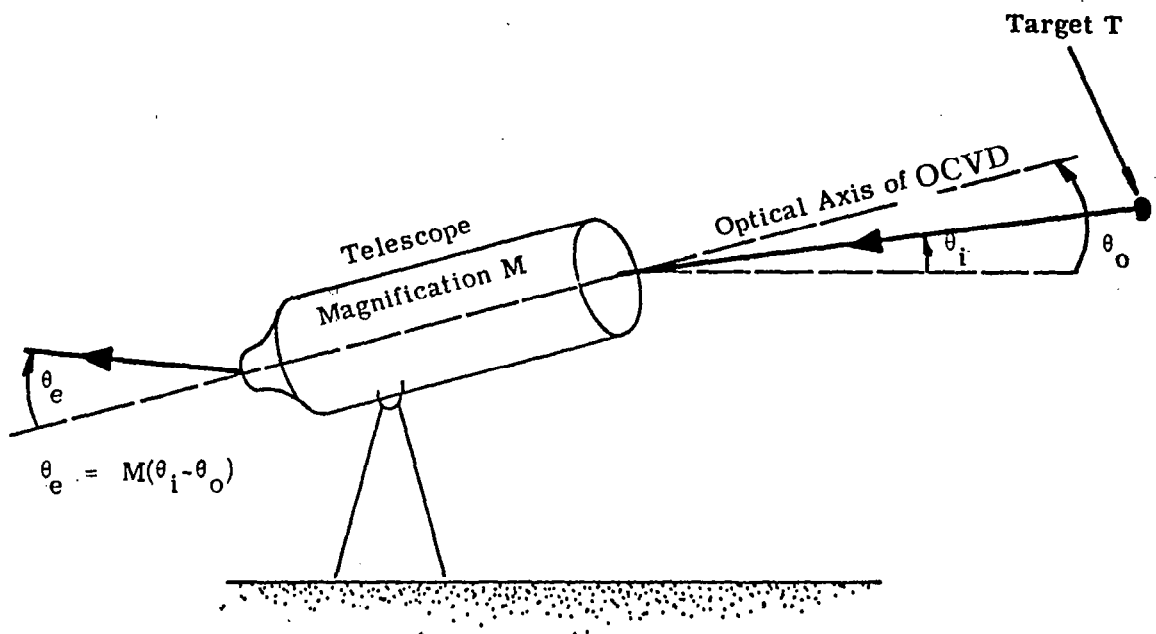

Figure A. 7 OCVD ANGLES

i. e.,

$$\delta \theta = \frac{E - 1}{1 + EF} \theta_i + \frac{n}{M} \frac{1 + F}{1 + EF} \quad (2)$$

The target angle at the eye θ_e is given by

$$\theta_e = \frac{M \theta_i}{1 + EF} + \frac{nF}{1 + EF} \quad (3)$$

To avoid the loss of track, the maximum θ_e should be less than half the field of view at the eye, or about 20° .

3.1.2.3 Stability

The stability of the OCVD depends on the zeros of the expression $[1 + E(p) F(p)]$. In order to simplify the analysis, it has been assumed that $E(p) = 1$. The range of validity of this assumption will be investigated. The method of analysis will be to plot the function $E(j\omega) \times F(j\omega)$ on the complex plane and to observe the proximity of the point $(-1, 0)$ to this curve.

Figure A. 8 shows a plot of the function $F(j\omega)$, where $F(p)$ is the feedback function considered in the main OCVD analysis.

It is of interest to consider the form of the plot of $E(j\omega) \times F(j\omega)$. Plots of $E(j\omega)$ made from measured data⁴⁻⁶ are shown in Figure A. 9. There is a considerable difference between the response to predictable and unpredictable motions. The general effect of $E(p)$ on $F(p)$ is to move the locus of $F(\omega)$ (Figure A. 8) toward the -1 point--i. e., to reduce stability. This

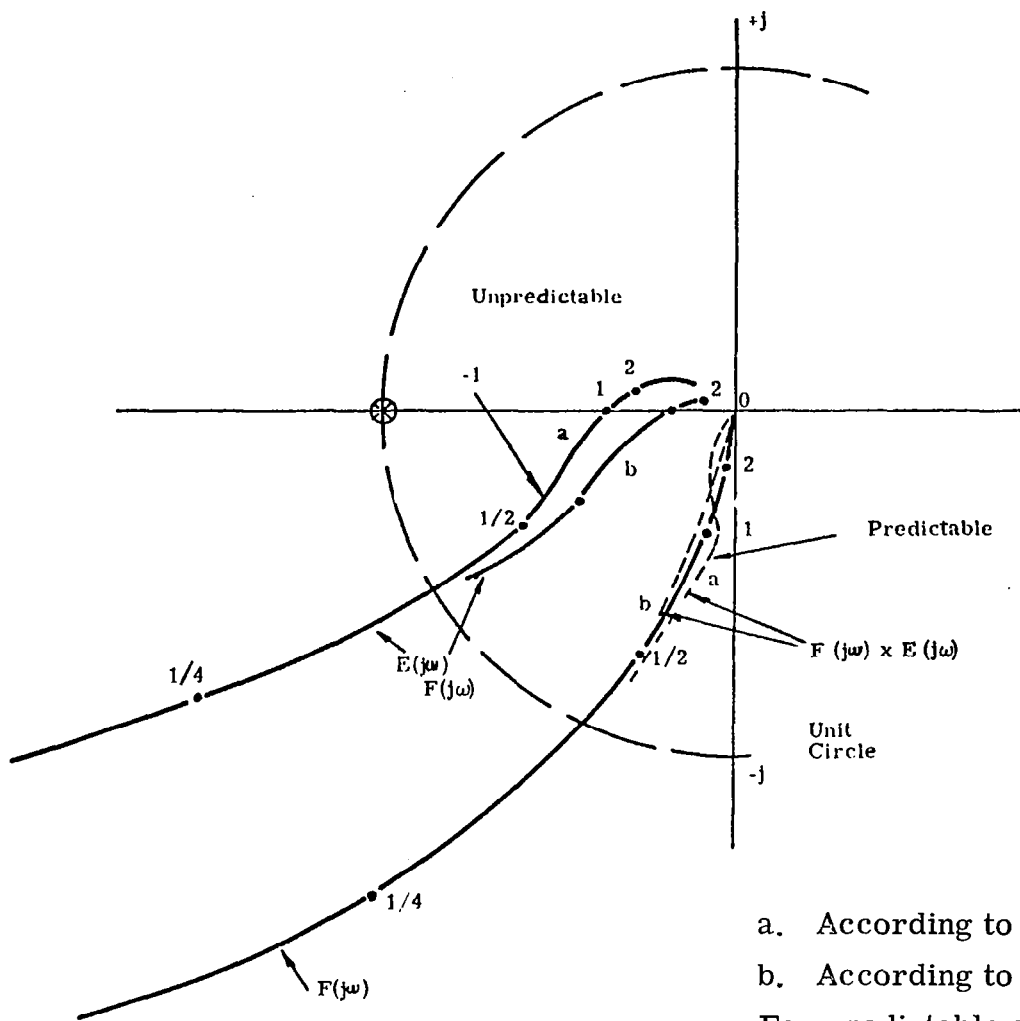

a. According to Ref 6)
 b. According to Ref 5) for E(jω)
 For predictable and unpredictable target motions,
 $f_0 = 1/4$ cps

Figure A.8 PLOT OF $F(j\omega)$ and $E(j\omega) \times F(j\omega)$

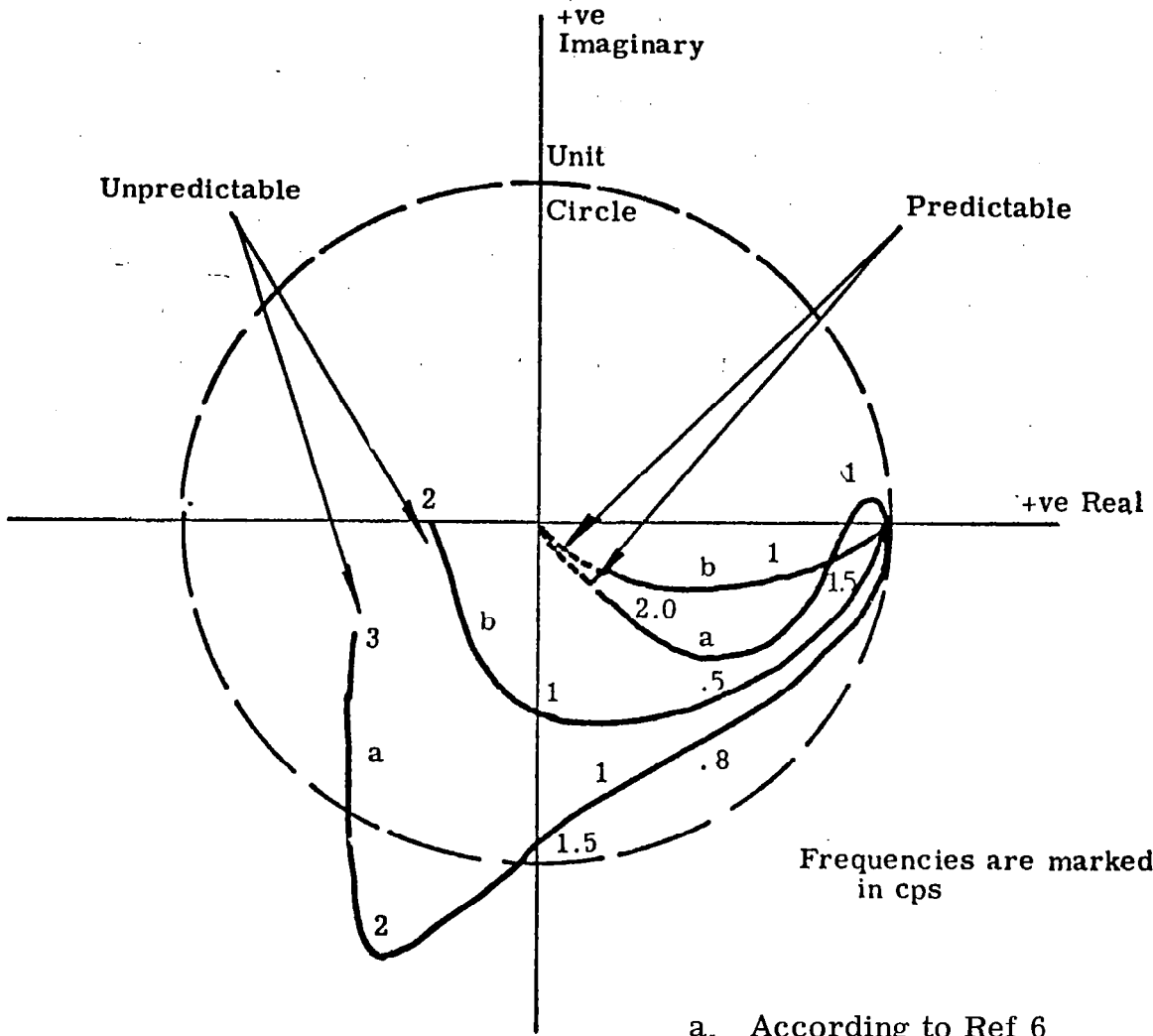

a. According to Ref 6
 b. According to Ref 5
 For predictable and unpredictable target motions

Figure A.9 PLOT OF $E(j\omega)$

effect can be mitigated by choosing a low value for f_o . For example, with $f_o = 1/4$ cps, the locus of $E(j\omega) \times F(j\omega)$ is generally clear of the -1 point. Another possible method of avoiding instability is to include a stabilizing network in the feedback loop.

Figure A. 8 shows that even with the "unpredictable" transfer function of the eye, the OCVD control loop, as described, is stable. Its transient performance would, however, be inferior to the results calculated assuming $E(p) \equiv 1$. The general form and steady state values of the transients would be the same, but there would be more overshoot (ringing). With the "predictable" eye transfer function, the assumption $E(p) \equiv 1$ would make very little difference in the transient responses. Only experiment can show the extent to which the eye will regard the OCVD apparent target motions (due partly to true "outside" signals and internally generated "ringing") as predictable or unpredictable. It is possible that the optimum OCVD feedback control will be nonlinear, with mode switching depending on the nature of the apparent target motions.

3.1.2.4 Response Functions

The equation giving target motion at the eye (θ_e) as a function of the input target motion θ_i is

$$\theta_e = \frac{M \theta_i}{1 + EF}$$

where it is assumed that $E \equiv 1$ and

$$F(p) = \frac{2 \zeta \omega_o}{p} + \frac{\omega_o^2}{p^2}$$

Then

$$\begin{aligned}\theta_e &= M \theta_i p^2 \frac{1}{p^2 + 2 \zeta p \omega_0 + \omega_0^2} \\ &= \frac{M \theta_i p^2}{(p - p_1)(p - p_2)}\end{aligned}$$

where $p_1, p_2 = -\zeta \omega_0 \pm \omega_0 \sqrt{\zeta^2 - 1}$

The value

$$\zeta = \frac{1}{\sqrt{2}}$$

has been chosen;

i. e.,

$$p_1, p_2 = -\frac{\omega_0}{\sqrt{2}} \pm j \frac{\omega_0}{\sqrt{2}}$$

The Laplace transform of the response θ_e to a step

$$L(M \theta_i) = \psi_1/p$$

is given by

$$\begin{aligned} L(\theta_{e_1}) &= \psi_1 p \frac{1}{(p - p_1)(p - p_2)} \\ &= \frac{\psi_1 p}{p_2 - p_1} \left(\frac{1}{p - p_2} - \frac{1}{p - p_1} \right) \end{aligned}$$

i. e.,

$$\begin{aligned} \theta_{e_1} &= \frac{\psi_1}{j\sqrt{2}\omega_0} \frac{d}{dt} \left[e^{-\frac{\omega_0 t}{\sqrt{2}}} \left(e^{\frac{j\omega_0 t}{2}} - e^{-\frac{j\omega_0 t}{2}} \right) \right] \\ &= \frac{\psi_1 \sqrt{2}}{\omega_0} e^{-\frac{\omega_0 t}{\sqrt{2}}} \left[-\frac{\omega_0}{\sqrt{2}} \left(\sin \frac{\omega_0 t}{\sqrt{2}} - \cos \frac{\omega_0 t}{\sqrt{2}} \right) \right] \\ &= \sqrt{2} \psi_1 e^{-\frac{\omega_0 t}{2}} \cos \left(\frac{\omega_0 t}{\sqrt{2}} + \frac{\pi}{4} \right) \end{aligned}$$

The Laplace transform of the response θ_{e_2} to a ramp

$$L(M\theta_i) = \frac{\psi_2}{p^2}$$

is given by

$$L(\theta_{e_2}) = \psi_2 \frac{1}{(p - p_1)(p - p_2)}$$

From the above,

$$\theta_{e_2} = \frac{\sqrt{2}}{\omega_0} \psi_2 e^{-\frac{\omega_0 t}{\sqrt{2}}} \sin \frac{\omega_0 t}{2}$$

The Laplace transform of the response θ_{e_3} to an accelerating ramp

$$L(M \theta_i) = \frac{\psi_3}{p^3}$$

is given by

$$\begin{aligned} L(\theta_{e_3}) &= \frac{\psi_1}{p} \frac{1}{(p - p_1)(p - p_2)} \\ &= \psi_1 \left(\frac{1}{p_2(p_2 - p_1)(p - p_2)} - \frac{1}{p_1(p_2 - p_1)(p - p_1)} + \frac{1}{p_1 p_2 p} \right) \\ \theta_{e_3} &= j \frac{\psi_1}{\sqrt{2} \omega_0} \left(\frac{2}{-\omega_0 + j\omega_0} e^{-\frac{\omega_0 t}{\sqrt{2}}} e^{+\frac{j\omega_0 t}{\sqrt{2}}} \right. \\ &\quad \left. - \frac{\sqrt{2}}{-\omega_0 - j\omega_0} e^{-\frac{\omega_0 t}{\sqrt{2}}} e^{-\frac{j\omega_0 t}{\sqrt{2}}} \right) + \frac{\psi_1}{\omega_0^2} \end{aligned}$$

$$= \frac{\psi_1}{\omega_0^2} \left[1 + \left(\frac{-1-j}{2j} e^{+\frac{j\omega_0 t}{\sqrt{2}}} - \frac{-1+j}{2j} e^{-\frac{j\omega_0 t}{\sqrt{2}}} \right) e^{-\frac{\omega_0 t}{\sqrt{2}}} \right]$$

$$= \frac{\psi_1}{\omega_0^2} \left[1 + e^{-\frac{\omega_0 t}{\sqrt{2}}} \left(-\sin \frac{\omega_0 t}{\sqrt{2}} - \cos \frac{\omega_0 t}{\sqrt{2}} \right) \right]$$

$$= \frac{\psi_1}{\omega_0^2} \left[1 + \sqrt{2} e^{-\frac{\omega_0 t}{\sqrt{2}}} \sin \left(\frac{\omega_0 t}{\sqrt{2}} + \frac{\pi}{4} \right) \right]$$

3. 1. 3 Potential Advantages of Oculometric Control in Visual Search and Tracking

Section 3. 1. 2 has applied the performance parameters of the eye to make a simple, theoretical estimate of how an oculometrically controlled tracking system might operate.

In general, the potential advantage of oculometric control is the improved efficiency (e. g. , speed) with which a very large amount of visual data can be searched and specific detail examined by the human eye. With oculometric control, the physical part of the total man/machine system involved is integrated with the basic sensor system, i. e. , the human eye. The design of a visual search system should not be concerned only with the physical part of the system. Man is an integral part of the system; the particular way in which his eye functions should be considered and applied in the overall system design.

In a search task the eye is operating as a low resolution, wide angle sensor. Almost always, target detail is first detected on the periphery of the retina, where acuity is much lower than at the fovea. Initial detection may occur anywhere over the 2π steradian field of the retina. Very rapidly, foveal vision is then deployed to examine the detail and check whether it is a genuine "target" or a "false alarm." In natural search, the false alarm rate can be quite high; hence the visual sense switches frequently between two quite different optical modes of operation:

search--in which the entire retina is applied to a
large area of the viewed image in relatively
low resolution sensing

examination--in which the foveal region is applied to a specific detail of the viewed scene in high resolution sensing.

Oculometric control in visual search and tracking permits automatic changing of the physical part of the viewing system to match the operating mode of the eye at any instant.

The oculomotor apparatus of the eye will largely control the physical part of the visual search system.

More specific advantages of oculometric control in visual search and tracking are:

1. improved ability to keep rapidly moving targets (e. g. , see Figures A. 4, A. 5, and A. 6) in the field of view.
2. greater accuracy with which high speed (or quick reaction) target position information can be read out from an operator. For example, experiments reported in Reference 7 show that it takes at least 2 seconds to place cross hairs on a target accurately by manual action (with a joy stick). The eye, however, can acquire a peripheral target within about 0.35 second (Reference 8).

In view of the important potential advantages of oculometric control of visual search and tracking, and the entirely novel human operator situation, it is recommended that oculometric control in a typical search and tracking system be simulated in real time.

3.2 Astronaut Maneuvering Unit

It is appropriate to consider, in general terms, the sequence of events in the operation of an AMU system:

1. The astronaut will observe his environment visually.
2. He will decide to move, in either rotation or translation.
3. The information defining his desired displacement vector will exist in some way in his brain.
4. The astronaut will compute the appropriate muscular control actions to cause the AMU to effect the desired motion.
5. The astronaut will execute these muscular actions.
6. The AMU will receive these commands from the astronaut and execute the desired displacement.

As noted earlier, it may be desirable that the astronaut use a muscle system other than his hands to communicate to his AMU. It is not a simple matter to find an alternative system. In normal life, the hands and the voice are our principal means of conveying information to the outside world. Thus voice control is a natural candidate for AMU control, as an alternative to hand action. One problem, however, is that electronic equipment is presently limited in its ability to accept and understand oral commands automatically. Circuits can be developed to decipher only a small vocabulary of precisely spoken commands. This restriction must be taken into account in considering a possible voice-controlled AMU system.

Finding an alternative to the hands is not the only problem in the AMU. Another is that the desired vector displacement information existing in the astronaut's

mind when he decides to move is generally not referred to the axis system of the AMU propulsion unit.

Consider the situation shown in Figure A. 10. The astronaut wishes to move toward the space vehicle, i. e. , to move along his z axis. To do so, however, he must command an appropriately balanced combination of x, y, and z thrusts from his AMU system. Not only must three output muscular channels from the astronaut be found, but also he must perform difficult mental calculations (axes transformation) and exercise very precise muscle control to achieve his desired motion.

The astronaut in Figure A. 10 could of course execute an appropriate rotation to make his axis frame accord with the AMU propulsion axes. However, the generation of rotational commands will also involve axis transformation. Generally, when an astronaut wishes to rotate he must either roll, pitch, or yaw relative to his own (mental) axis system. In Figure A. 11, for example, the astronaut wishes to roll relative to his own axis system. To do so he must command torques of roll, pitch, and yaw in the AMU propulsion unit axis system. Again three muscular output channels are involved, difficult mental computations must be performed, and muscular control must be precisely balanced to obtain the correct combination of roll, pitch, and yaw torques from the AMU unit.

If it were possible to continuously measure the direction of pointing of the astronaut's eyes relative to the AMU propulsion unit, the difficulties associated with axis transformation could be avoided.

A-143

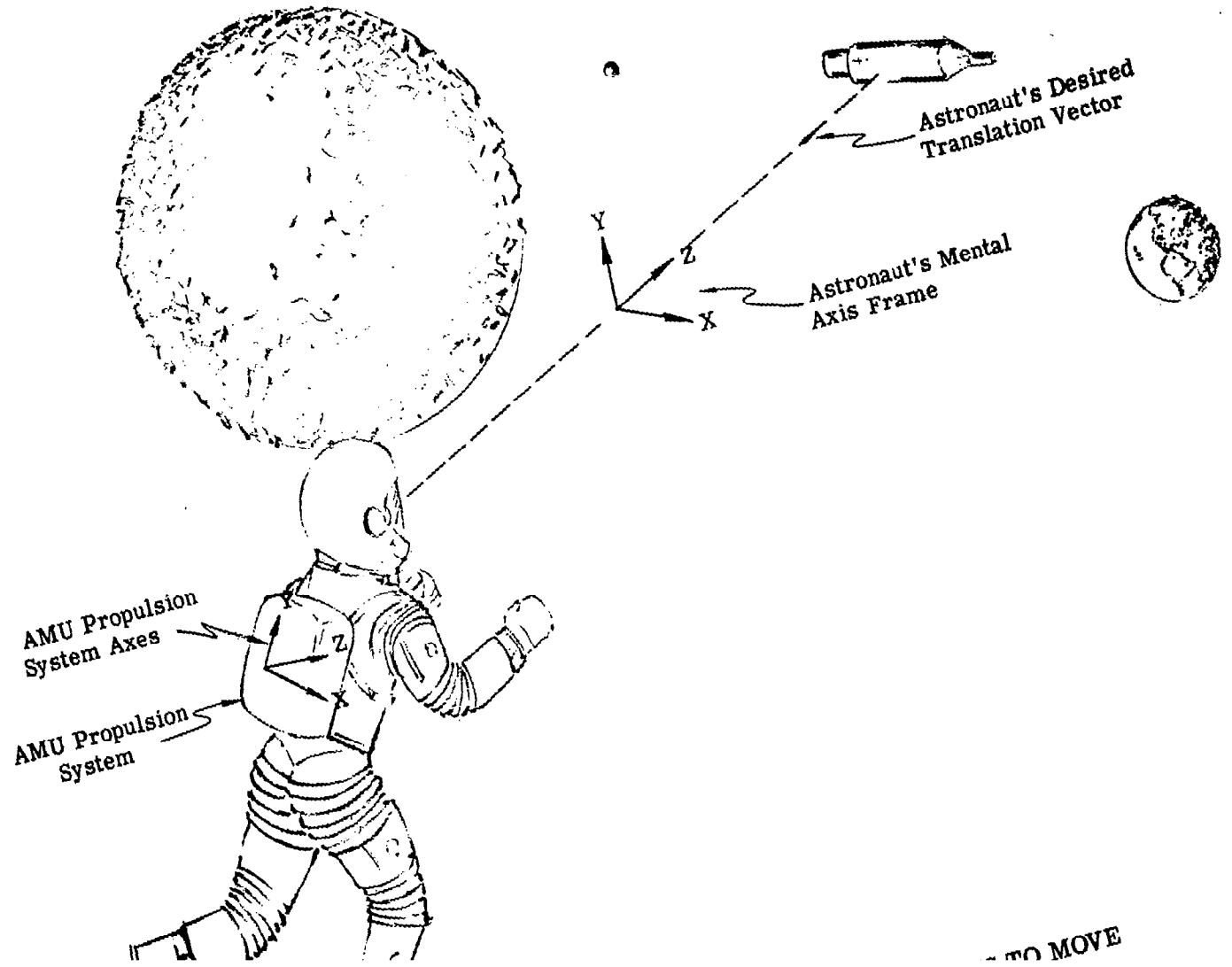

- TO MOVE

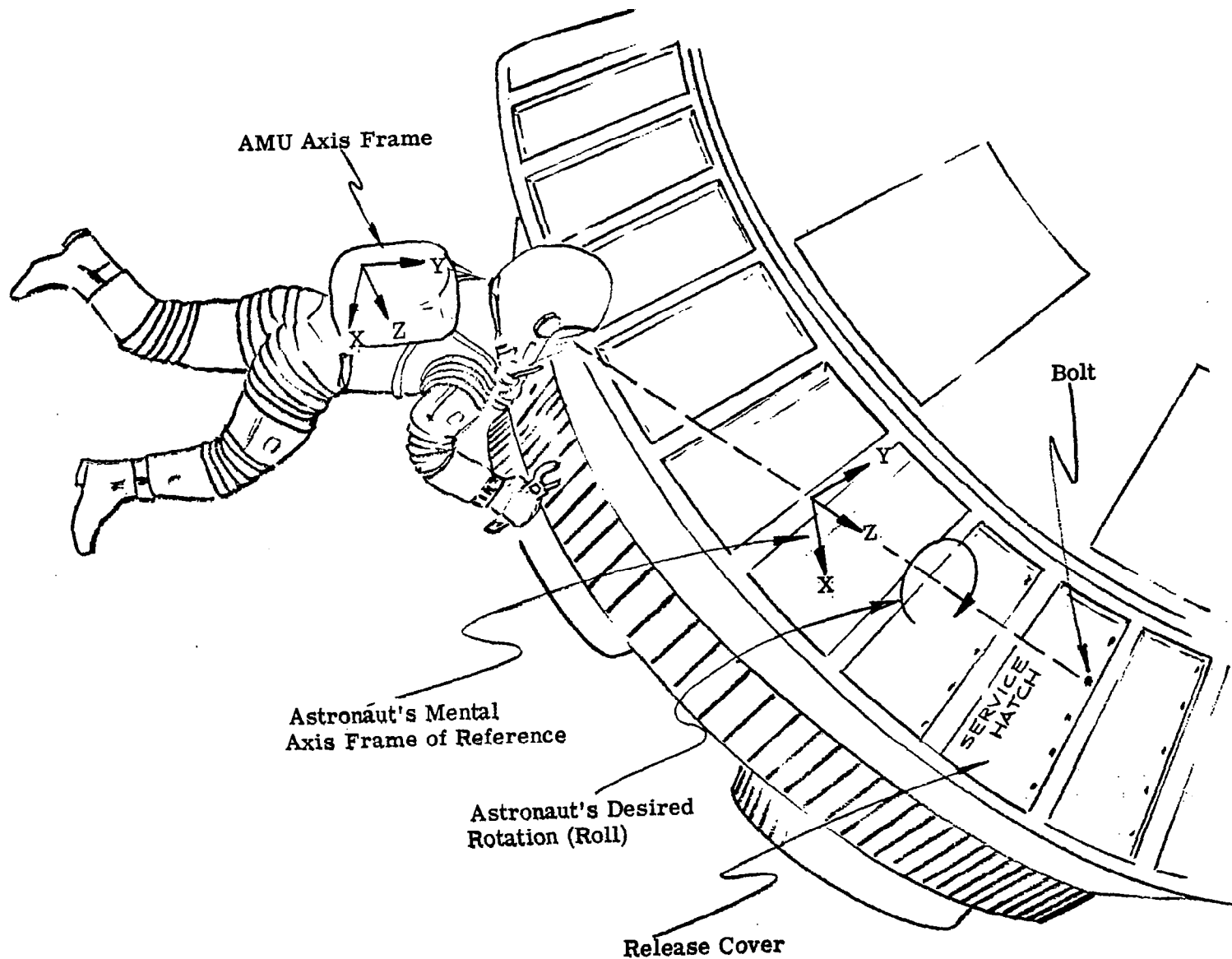

Figure A. 11 ASTRONAUT DESIRES TO ROLL IN HIS OWN AXIS FRAME

Consider therefore an AMU system which uses a helmet-mounted oculometer to measure the astronaut's eye direction relative to the helmet, and a helmet angle sensing system (e. g. , the optical pickoff device used on Honeywell's Helmet Sight System) to measure the helmet angle or position relative to the AMU propulsion unit.

Enough information exists in this system to define the vector position of the astronaut's gaze relative to the AMU propulsion axes. The gaze vector is undoubtedly the "in-out" (z) axis of the astronaut's natural mental frame of reference. However, it is not immediately clear as to what, in general, defines his natural left-right and up-down axes. For a person in a gravitational field, the direction of this field probably determines the direction of the up-down axes; together with the "in-out" axis defined by the gaze vector, this then fixes the person's mental frame of reference (Figure A. 12). For an astronaut in a zero g field, however, it seems likely that the line joining his eyes would define his natural "left-right" axis, which together with his gaze vector would then define his natural frame of reference (Figure A. 13). It is of course possible that the axis system in a person's mental frame of reference (i. e. , "in-out," "left-right," "up-down") may not, in general, be orthogonal. See Figure A. 14.

The important conclusion that can be drawn, however, is that once the direction of the gaze vector and the attitude of the head are known relative to the AMU propulsion unit, the mental frame of reference of the subject is defined whether it be as indicated in Figure A. 12, or in Figure A. 13, or even if the axes are not orthogonal (Figure A. 14). With his mental axis frame thereby known by the AMU, the astronaut can communicate to the AMU in his own frame of reference, and the correct AMU propulsion thrusts and torques can be automatically computed by axis transformation.

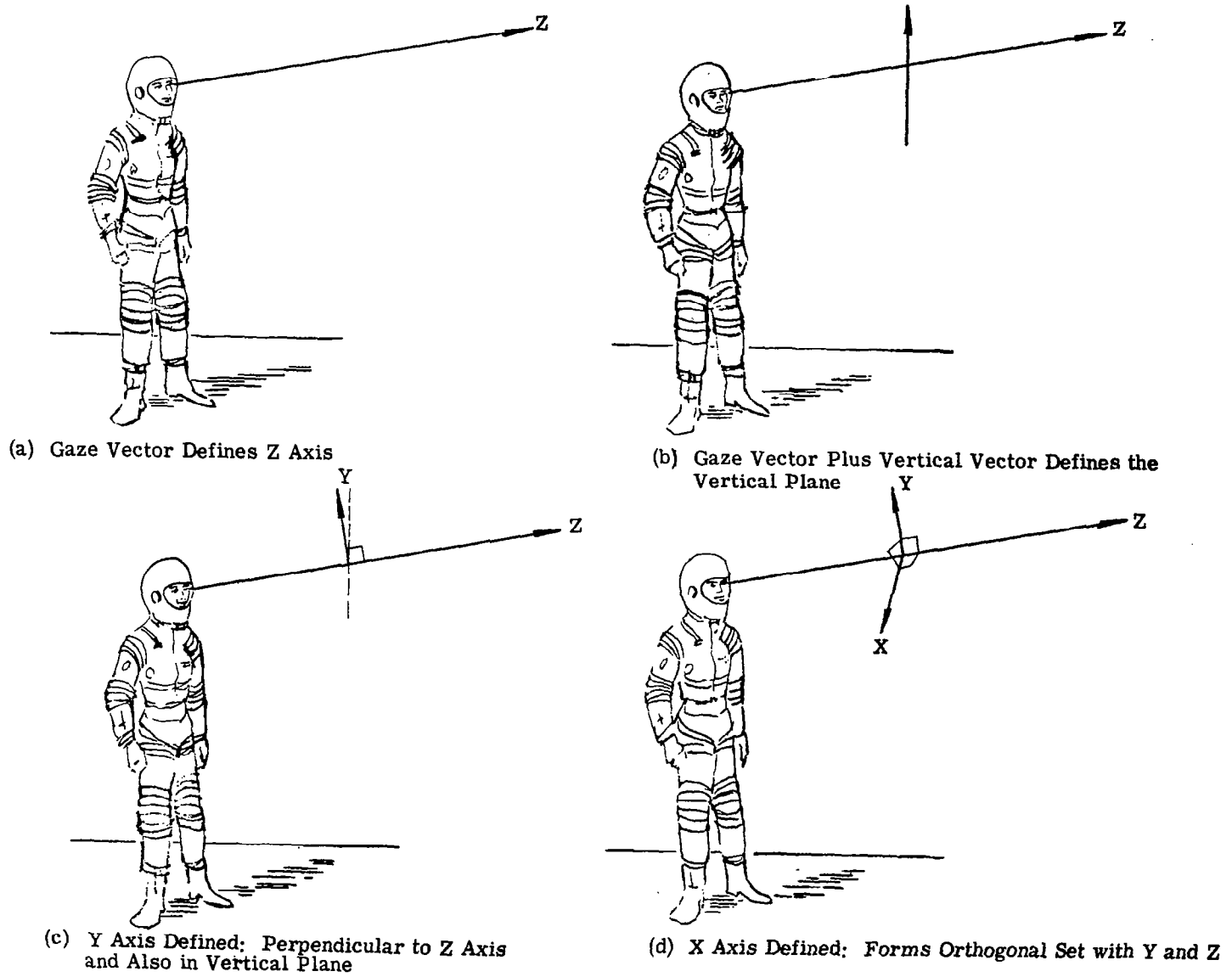
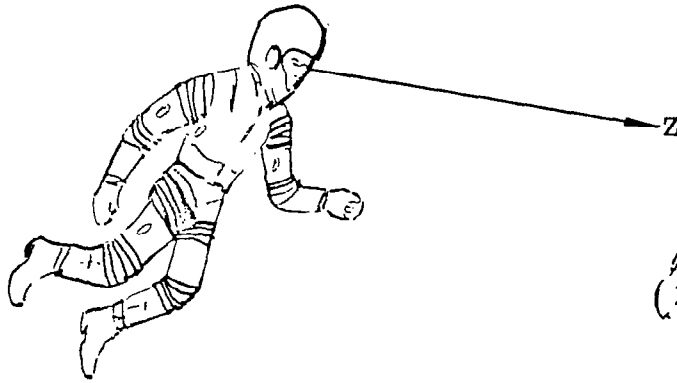
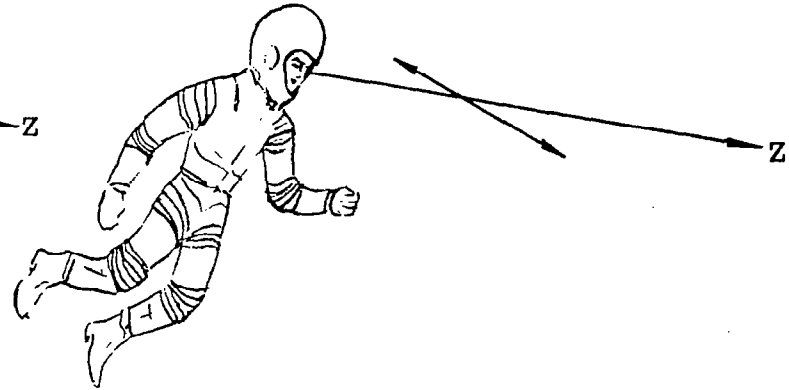

Figure A. 12 MENTAL FRAME OF REFERENCE IN A GRAVITATIONAL FIELD



(a) Gaze Vector Defines Z Axis



(b) Gaze Vector Plus Line Joining Eyes Define the "Horizontal" Plane

A-47

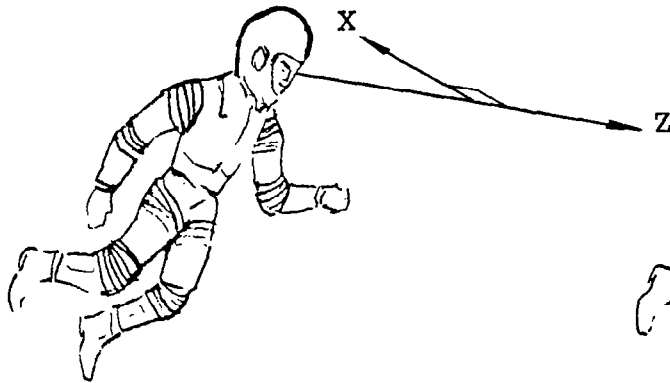

(c) X Axis is Defined: Perpendicular to Z Axis and Also in the "Horizontal" Plane

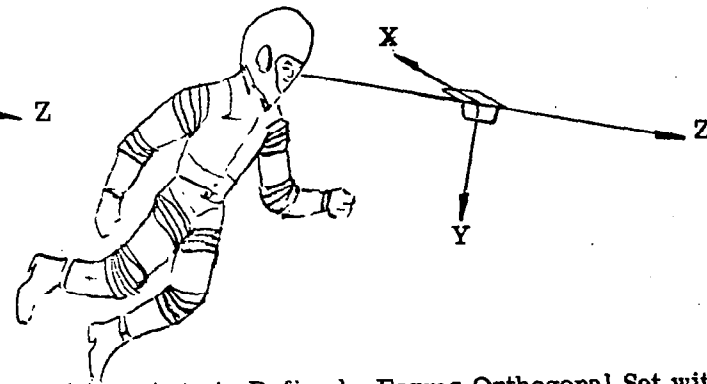

(d) Y Axis is Defined: Forms Orthogonal Set with X and Z

Figure A. 13 POSSIBLE MENTAL FRAME OF REFERENCE IN A ZERO G FIELD

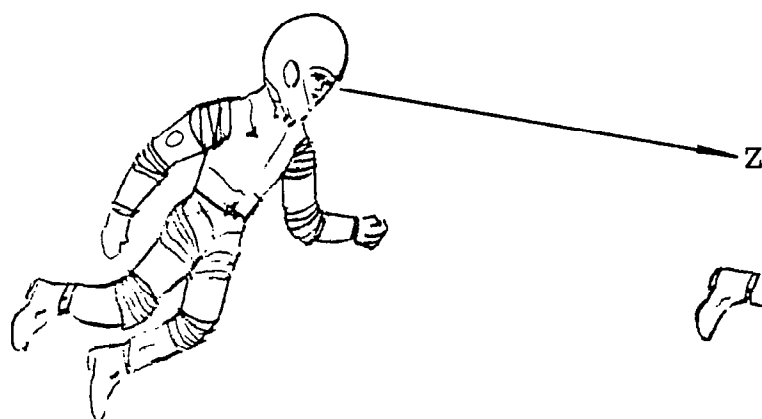

(a) Gaze Vector Defines Z Axis

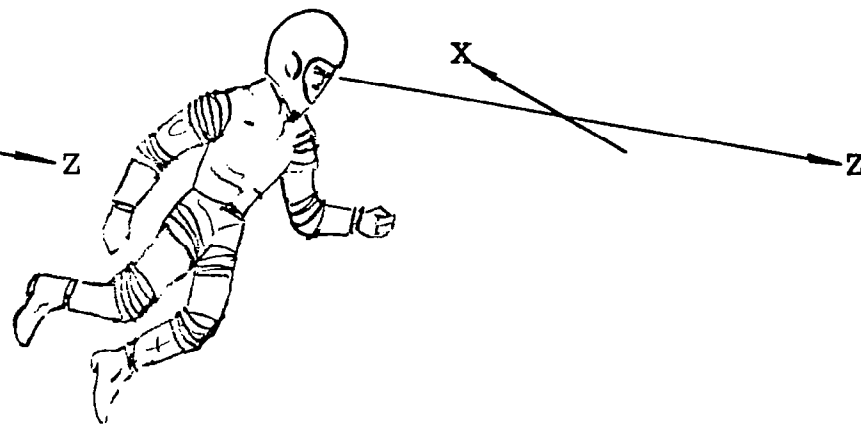

(b) Line Joining Eyes is X Axis

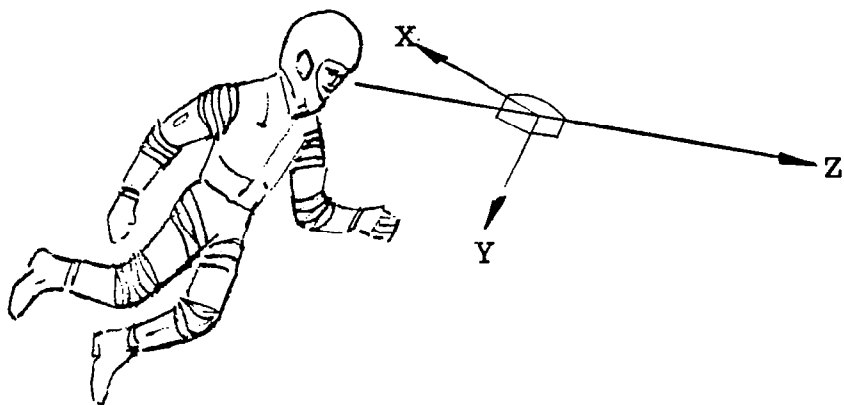

(c) Y Axis is perpendicular to Plane of X and Z

A-48

Figure A. 14 POSSIBLE NONORTHOGONAL MENTAL
 AXIS FRAME IN A ZERO G FIELD
 (In General, \vec{X} is not perpendicular to \vec{Z})

The practical advantage of this procedure might be substantial. Suppose that voice control is to be used and that the astronaut shown in Figure A. 11 wishes to rotate as indicated--i. e. , in his natural frame of reference.

If automatic axis transformation is not used, the astronaut must either attempt three separate motions in sequence, e. g. ,

```
"pitch* up"--"stop pitch* up"  
"yaw* left"--"stop yaw* left"  
"roll* clockwise"--"stop roll* clockwise"
```

or attempt to command the appropriate combination of roll*, pitch*, and yaw* displacements simultaneously:

```
"roll* 10° clockwise and yaw* 17° left and pitch* 15° up"
```

In either case the operation will be time consuming and mentally demanding; it will almost certainly be subject to significant trial and error, resulting in AMU fuel wastage. If, on the other hand, the astronaut's eye direction and head position are measured, and his AMU commands--expressed in his own frame of reference--are automatically converted to the AMU axes, then his

*Referred to the AMU propulsion unit axes.

task is much simplified. He would, for example, either command:

"roll clockwise"--"stop roll clockwise"

or

"roll clockwise 15°"

The underlying assumptions that have been made are:

- (1) an astronaut would almost never have a conscious desire to move, or rotate, in a direction that was not along, or about, one of the three axes of his mental frame of reference
- (2) a unique mental frame of reference can be defined as a function of the attitude of the astronaut's eyes and head

Further study or experimentation may be required to determine what exactly is the natural mental frame of reference of a subject under any given set of conditions.

The possible advantages of the use of the oculometer in the AMU system are:

1. faster operation, because the commands that must be transmitted from the astronaut to the AMU propulsion unit are simplified
2. greater astronaut efficiency, because most of the mental activity involved in generating AMU commands is eliminated

3. lower fuel consumption by the AMU propulsion unit, because the AMU system executes the astronaut's desired changes in position and attitude more efficiently

4. INSTRUMENT DESIGN

4.1 Basic Configurations

Two basic configurations of the oculometer have been recognized:

telescopic oculometer: the oculometer is part of a fixed (e. g. , bench- or panel-mounted) optical unit, having an eyepiece through which the operator looks at the scene. The eyepiece serves also to image the eye onto the electro-optical sensor in the unit.

head- (or helmet-) mounted oculometer: the oculometer is mounted on a helmet (or other suitable head gear) worn by the operator. A transparent (in the visible spectrum) visor is located in front of the operator's eye to reflect (in the nonvisible operating spectrum of the oculometer) an image of the eye onto the electro-optical sensor. The operator has clear, naked eye vision, with no head restraint.

4.2 Measurement Principles

Two basic measurement principles may be noted:

fixed corneal light source: the light which is incident at the eye, and forms the corneal reflection in the pupil is in a fixed direction. Thus,

as the eye moves, the corneal reflection moves in the pupil. Eye direction is indicated by the position of the corneal reflection in the pupil.

moving corneal light source: the light forming the corneal reflection is incident at the eye in varying directions. The direction is controlled so that the corneal reflection is brought to the center of the pupil. Eye direction is basically proportional to the direction of the incident light.

The principle of the fixed corneal light has the advantage of simplicity, but the moving light technique is generally preferable, because of:

1. improved linearity
2. less axis crosstalk
3. less sensitivity to changes in magnification in the optical system that images the eye onto the photocathode as the eye moves toward and away from the oculometer

4.3 Electro-Optical Sensors

Several electro-optical sensors can be considered for an oculometer system.

4.3.1 Image Dissector

The brightness of a given area of the eye can be analyzed, at any one time, with an image dissector. The particular location of this area over the field of view of the tube is selected by the magnitude of the current flowing

in the magnetic deflection coils. The shape of the area is determined by the shape of the hole in the aperture plate within the tube. This shape can be specified within certain limits.

The spectral region to which these tubes can be sensitive ranges from 0.3μ to 1.0μ , with a quantum efficiency of 20% (at 0.45μ) to 0.1% (at 1.0μ).

The tubes are capable of very high resolution (of the order of 10^3 television lines, depending on the type of aperture). Their principal limitations are:

1. size and weight (e. g. , 8" x 2", 5 lb)
2. nonstorage operation

Nonstorage operation means that they respond, at any time, only to the light emanating from one small region of the eye. Thus if the eye is uniformly illuminated, most of the illumination is "wasted." Since the oculometer system is limited by the amount of radiation that can be safely and comfortably directed at the eye, all the radiation incident at the eye should be used, rather than only part of it.

4. 3. 2 Image Dissector with Fiber Optics Link

With the use of fiber optics, the tube may be located away from the oculometer proper, and its size and weight will not be so significant a limitation. This consideration applies, for example, to the helmet-mounted oculometer, where a fiber optics link will permit the heavy tube to be located in a back or chest pack.

4.3.3 Vidicon

This tube has the advantages of storage operation and relatively small size and weight, but is less sensitive and has poorer resolution than the image dissector. On balance, it is an attractive component candidate for the oculometer in a suitably designed system.

4.3.4 Flying Spot Scan System

In the use of the image dissector, the eye is covered with essentially uniform illumination and the corresponding brightness of various elemental areas of the eye is sensed. An alternative, and very similar, arrangement is to use a single, wide aperture detector (e.g., a conventional photomultiplier tube) and illuminate the eye with a very small scanning spot. In both techniques, the reflectivity of any small element of the eye can be sensed by applying the appropriate deflection command to the scanning system (the image dissector scan coils in one case, the small scanning light beam in the other). The detection sensitivity of the two systems will be of the same order, but in the flying spot system only that part of the eye being analyzed at any one time will be illuminated. Thus if the illumination level is limited by how much total radiation (or radiation density over a period of, say, 1/10 second) can safely or comfortably be directed at the eye, then the flying spot system has a clear advantage. No part of the eye receives radiation that is not used by the detector.

A further possible advantage is that the total size and weight of the flying spot components (a simple PM tube and a scanning light source) might be less than that of an image dissector tube.

Note that if the system is limited only by the allowed radiation level at the eye, not by the intensity of the radiation source, then a high F number can be used in the optical system that images the scanning light beam onto the eye. This means that the spot will remain sharply focused over a wide range of axial positioning of the eye. The F number of the PM tube collecting optics can be small, however, without affecting the resolution of the system. The low F number of the detector optics will enhance the effective sensitivity of the PM tube detector. With the image dissector system, on the other hand, the F number of the detection optics must be relatively high in order to provide reasonably good depth of focus. In other words, resolution and sensitivity are reciprocally related in an image dissector system but can be made independent in a flying spot system.

4.3.5 Detector Array

No commercially available detector arrays appear to have a sufficient density for the oculometer application. Such arrays are now being developed, however, and may prove an attractive sensing method in the next few years.

4.3.6 Scannistor

The scannistor is a solid state detector cell in which the output signal is proportional to the input light incident over a certain region of the cell active area.⁹⁻¹¹ The size of the cell which is effectively sensitive can be determined by the magnitude of a control voltage. One dimensional electronic (nonmechanical) scanning is possible with the device. To a

certain extent, the coordinate system in which this scanning dimension is referred is a design parameter.

The scannistor is relatively noisy and has not been fully developed. It should, however, be considered in the design of a specialized oculometer. The pattern that must be detected in the oculometer--the black disc (pupil) containing a bright spot (corneal reflection)--is sufficiently simple so that the restricted scanning capability of the scannistor may not be a serious limitation.

4.3.7 Correlation Detector

The very simple and repeatable nature of the optical pattern to be detected in the oculometer indicates that image correlation techniques might be used to detect the position of the pupil and possibly also that of the point corneal reflection. The correlator would contain a "reference" image defining the pupil. This might be a simple black disc or possibly a photograph of a particular subject's eye. In the operation of the correlator, an image of the actual eye pupil would be superimposed on the "reference." The total light flux passed would then be proportional to the cross correlation coefficient between the pupil and the reference.

This correlation is a maximum when the pupil and reference are in exact match. In a particular correlator configuration (unfocused, Meyer Eppler), an image of a region of the cross correlation function is so produced that the "match position" can be detected by scanning over the correlation image (e. g. , with a vidicon) to determine the coordinates of that point having a maximum intensity.

4.3.8 Lateral Photo Effect Device

A lateral photo effect silicon detector can provide two analog signal outputs, proportional to the x, y coordinates of a point source of light incident on the detector, referred to axes fixed in the detector. This device appears, therefore, as a candidate for detection of the position of the corneal reflection and possibly, with some modification, for detection of the pupil.

4.4 Recommended Configurations

Table A.1 lists the various applications that have been discussed, showing the general oculometer configuration recommended in each case. It must be borne in mind that the appropriate equipment and configuration in a specific application may differ from the recommendations shown because of the highly specific parameters of any one application.

TABLE A. 1
OCULOMETER APPLICATIONS AND RECOMMENDED CONFIGURATIONS

<u>Application</u>	<u>Basic Configuration</u>	For Present Systems:	For Future Systems:
		<u>Electro-Optical Sensing Method</u>	<u>Specialized Solid State Research and Development Recommended</u>
Telescope Pointing	Telescopic	Flying Spot or Image Dissector	--
Telescope Zoom Control	Telescopic	Flying Spot or Image Dissector	--
Image Stabilization	Telescopic	Flying Spot or Image Dissector	--
Analysis of Photographic Data	Telescopic	Flying Spot or Image Dissector	--
Microscope Examinations	Telescopic	Flying Spot or Image Dissector	--
AMU	Helmet	Flying Spot or Vidicon	Yes
Air Traffic Control	Helmet	Flying Spot or Vidicon	Yes
Laser Communication	Helmet	Flying Spot or Vidicon	Yes
Information Retrieval	Helmet or Telescopic	Flying Spot, Image Dissector, or Vidicon	Yes
Quality Inspection	Helmet	Flying Spot or Vidicon	Yes
TV--Remote Vision	Helmet	Flying Spot or Vidicon	Yes
Remote Handling	Helmet	Flying Spot or Vidicon	Yes
Alertness Monitor	Helmet	Flying Spot or Vidicon	Yes
Analysis of Reading	Telescopic	Flying Spot or Image Dissector	--
Use with Infants	Special Form of Helmet	Flying Spot or Vidicon	Yes
Psychological Testing	Telescopic or Helmet	Flying Spot, Image Dissector or Vidicon	Yes
Pilot Training	Helmet	Flying Spot or Vidicon	Yes

5. REFERENCES

1. L. R. Young, "Measuring Eye Movement," American Journal of Medical Electronics 2, No. 4, pp. 300-307.
2. D. E. Berlyne, Curiosity and Exploration Science 153, pp. 25-33 (1 July 1966).
3. R. E. Hufnagel and N. R. Stanley, "Modulation Transfer Function Associated with Image Transmission through Turbulent Media," Journal of the Optical Society of America 54, p. 52 (1964).
4. L. Stark, G. Vossius, and L. R. Young, IRE Transactions on Human Factors in Electronics, September 1962.
5. P. J. Dallos and R. W. Jones, IEEE Transactions on Automatic Control, July 1963.
6. L. R. Young and L. Stark, IEEE Transactions on Human Factors in Electronics, September 1963.
7. W. L. Jenkins and A. C. Karr, "The Use of a Joy Stick in Making Settings on a Simulated Scope Face," Journal of Applied Psychology 38, No. 6, pp. 457-461 (1954).
8. C. T. White and R. G. Eason, "Latency and Duration of Eye Movements in the Horizontal Plane," Journal of the Optical Society of America 52, No. 2, pp. 210-213 (1962).
9. S. R. Morrison, "A New Type of Photosensitive Junction Device," Solid State Electronics 5, pp. 485-494 (1963).
10. J. W. Horton, Radiation Scanner, IBM Technical Disclosure Bulletin 6, No. 2, pp. 73-74 (July 1963).
11. J. W. Horton, R. V. Mazza, and H. Dym, "The Scannistor - A Solid State Image Scanner," Proceedings of the IEEE, pp. 1513-1528, 1964.

APPENDIX B

GEOMETRY OF EYE MEASUREMENT TECHNIQUE

The principle of the measuring technique can be readily demonstrated by direct observation of the eye. The apparent position, to an observer, of the corneal reflection within the eye, relative to the center of the pupil, is independent (to first order) of the lateral position of the eye of the subject relative to the observer, but is directly proportional to the angular direction of the subject's eye relative to the (distant) source reflected in his cornea.

The following is a simple geometric proof of this phenomenon. Referring to Figure B.1, the coordinates of R (the virtual image of the collimated light incident at the eye, at angle θ to the axis of the eye) relative to axes through P, parallel to PC, are $(r_1 - r_2 \cos \theta)$, $r_2 \sin \theta$.

Let the "y" coordinate of R relative to axes through P, parallel to PO, be δ ; then,

$$\delta = r_2 \sin \theta \cos (\psi - \theta) - (r_1 - r_2 \cos \theta) \sin (\psi - \theta)$$

where ψ is the angle of observation of the eye, relative to the direction of the incident light. Therefore,

$$\begin{aligned} \delta &= r_2 \sin \psi - r_1 \sin (\psi - \theta) \\ &= 2r_1 \cos (\psi - \theta/2) \sin \theta/2 + (r_2 - r_1) \sin \psi \end{aligned}$$

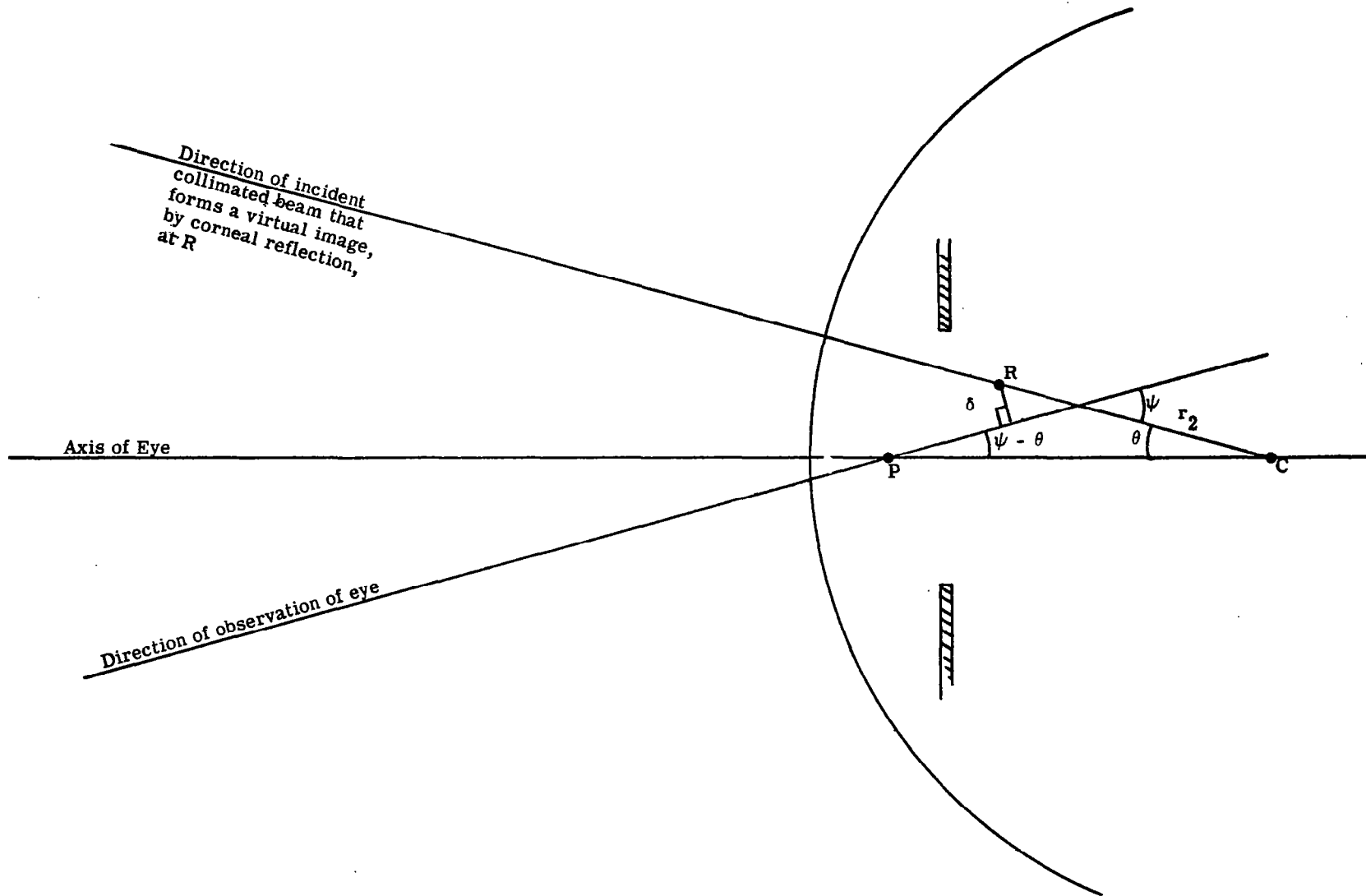

Figure B.1 GEOMETRY OF EYEBALL

There are three particular cases of interest:

1. The direction of the incident light is adjusted so that the corneal reflection appears to be at the center of the pupil (i. e., $\delta = 0$). Then $\delta = 0$ and, assuming ψ is not large,

$$2r_1 \sin \theta/2 \approx - (r_2 - r_1) \sin \psi$$

$$\theta \approx \frac{-(r_2 - r_1)}{r_1} \psi$$

That is, the axis of the eye is approximately parallel to the direction of the incident collimated light, and eye direction can then be measured by measuring the direction of the incident light (a small correction, $\theta \approx \frac{(r_2 - r_1)}{r_1} \psi$, must be included).

2. The direction of the eye is determined by measuring δ and ψ .

If ψ is not large, and also if $\theta/2$ is not large, then

$$\delta \approx r_1 \theta + (r_2 - r_1) \psi$$

$$\theta \approx \frac{\delta}{r_1} - \frac{(r_2 - r_1)}{r_1} \psi$$