

TMX 53107



THE MERCURY - REDSTONE PROJECT

FACILITY FORM 802	N67-37935	
	(ACCESSION NUMBER)	(THRU)
	278	1
	(PAGES)	(CODE)
	TMX-53107	31
	(NASA CR OR TMX OR AD NUMBER)	(CATEGORY)

SATURN/APOLLO SYSTEMS OFFICE

National Aeronautics and Space Administration

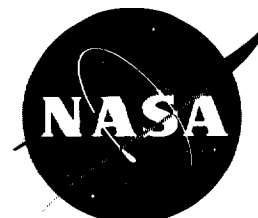

THE MERCURY-REDSTONE PROJECT

December 1964

SATURN/APOLLO SYSTEMS OFFICE
GEORGE C. MARSHALL SPACE FLIGHT CENTER
NATIONAL AERONAUTICS AND SPACE ADMINISTRATION
HUNTSVILLE, ALABAMA

FOREWORD

The purpose of this report was to collect, into a single volume, a concise but complete history of the development program for the United States' first manned launch vehicle and to identify the significance of this program for the design and operation of future manned launch vehicles.

The report was prepared by the Apollo Support Department of the General Electric Company for the SATURN/Apollo Systems Office of the George C. Marshall Space Flight Center, NASA, Huntsville, Alabama. The information contained in the report has been obtained from reviews of a large number of project reports, which are included in the Bibliography, and personal interviews with technical personnel who were part of the MERCURY-REDSTONE team. Some of the major contributors to the MERCURY-REDSTONE launch vehicle were the Army Ballistic Missile Agency, the Marshall Space Flight Center and Space Task Group (both of NASA), Chrysler Corporation and the Rocketdyne Division of North American Aviation, Inc.

The report was prepared by the following General Electric personnel:

- F. E. Miller, Engineer
- J. L. Cassidy, Engineer
- J. C. Leveye, Technical Writer
- R. I. Johnson, Project Leader

The project was directed by:

- Dr. J. P. Kuettner, Deputy Director, SATURN/Apollo Systems Office, MSFC (formerly Director, Mercury-Redstone Project)

TABLE OF CONTENTS

	<u>Title</u>	<u>Page</u>
SECTION 1	- <u>SUMMARY</u>	
SECTION 2	- <u>INTRODUCTION</u>	
SECTION 3	- <u>MERCURY-REDSTONE MISSION</u>	
	3.1 Mission Objectives	3-1
	3.2 Flight Trajectory	3-3
	3.3 Mission Profile and Sequence of Events	3-5
SECTION 4	- <u>VEHICLE DESCRIPTION</u>	
	4.1 Introduction	4-1
	4.2 Structure	4-1
	4.3 Propulsion System	4-7
	4.4 Control System	4-12
	4.5 Electrical Power Network	4-32
	4.6 Communications, Telemetry, and Television	4-34
	4.7 Fuel Dispersion (Destruct) System	4-39
	4.8 Initial Design Changes	4-39
	4.9 Later Modifications	4-44
SECTION 5	- <u>MAN-RATING</u>	
	5.1 Introduction	5-1
	5.2 Automatic Inflight Abort Sensing System	5-1
	5.3 Reliability Program	5-31
SECTION 6	- <u>DEVELOPMENT TEST PROGRAM</u>	
	6.1 Introduction	6-1
	6.2 Vehicle Test Program	6-1
	6.3 Special Reliability Tests	6-11
	6.4 Mass Dampening of Inflight Vibrations	6-17
	6.5 Booster Recovery System Development	6-22
SECTION 7	- <u>CHECKOUT AND LAUNCH OPERATIONS</u>	
	7.1 Prelaunch Preparation	7-1
	7.2 Launch Organization and Countdown	7-6
	7.3 Emergency Egress Operations	7-35
	7.4 Range Safety	7-42
	7.5 Special Launch Facilities and Displays	7-44
	7.6 Meteorological Aspects	7-73
SECTION 8	- <u>FLIGHT TEST PROGRAM</u>	
	8.1 Introduction	8-1
	8.2 Development Flights	8-2
	8.3 Manned Flights	8-18
	8.4 Operational Changes Resulting from Flight Testing	8-26
SECTION 9	- <u>CONTRIBUTIONS TO MANNED LAUNCH VEHICLES</u>	
	9.1 Introduction	9-1
	9.2 Man-Rating	9-1
	9.3 Design	9-5
	9.4 Testing	9-7
	9.5 Operations	9-8
	9.6 Conclusion	9-8
SECTION 10	- <u>REFERENCES</u>	iii

LIST OF ILLUSTRATIONS

<u>Figure</u>	<u>Title</u>	<u>Page</u>
1-1	The REDSTONE, JUPITER-C, and MERCURY-REDSTONE Launch Vehicles	1-4
3-1	Dynamic Pressure During Boost, MR-4 Mission	3-3
3-2	Velocity During Boost, MR-4 Mission	3-4
3-3	Axial Acceleration versus Time, MR-4 Mission	3-4
3-4	Typical Flight Profile, MERCURY-REDSTONE	3-6
3-5	Block Diagram of MERCURY-REDSTONE Mission Sequence	3-8
4-1	Booster Units	4-2
4-2	Exploded View of Launch Vehicle Structure	4-3
4-3	A-7 Rocket Engine	4-8
4-4	Engine Starting Sequence Diagram	4-10
4-5	Engine Cutoff Sequence Diagram	4-11
4-6	Pneumatic System	4-13
4-7	Details of Booster Control System	4-14
4-8	Mechanics of Tilting Program	4-16
4-9	Pulse Program for Tilting	4-17
4-10	MERCURY-REDSTONE LEV-3 Stabilizer System	4-18
4-11	MERCURY-REDSTONE Center of Gravity and Center of Pressure Location During Time of Flight	4-22
4-12	MERCURY-REDSTONE Flight Bending Moment Distribution T = 80 Seconds	4-23
4-13	MERCURY-REDSTONE Relative Amplitude versus Missile Station T = 60 Seconds Free-Free Lateral Bending Modes	4-24
4-14	Maximum Design Wind Velocity versus Altitude	4-25
4-15	MERCURY-REDSTONE Free-Free Lateral Bending Natural Frequency versus Flight Time	4-26
4-16	MERCURY-REDSTONE Free-Free Longitudinal Natural Frequency versus Flight Time	4-27
4-17	MERCURY-REDSTONE Comparison of Angle of Attack versus Time	4-28
4-18	Effects of Pitch and Yaw Hardover on Vehicle Angle of Attack (As a function of flight time.)	4-29
4-19	MERCURY-REDSTONE Effects of Yaw and Pitch Hardover on Vehicle Attitude Angle (As a function of flight time.)	4-30

LIST OF ILLUSTRATIONS (CONT.)

<u>Figure</u>	<u>Title</u>	<u>Page</u>
4-20	MERCURY-REDSTONE Effect of Roll Hardover at 80 Second Flight Time (Worst Case)	4-31
4-21	Electrical Power Distribution	4-33
4-22	Antenna Locations	4-36
4-23	Fuel Dispersion (Destruct) System	4-40
4-24	Installation of Dampening Compound in Instrument Compartment and Adapter Section	4-46
4-25	Ground Strap Function just After Liftoff	4-47
5-1	Block Diagram of MERCURY-REDSTONE Automatic Inflight Abort Sensing System	5-3
5-2	Thrust Buildup	5-8
5-3	Abort Responsibility Assignments versus Time for Manned MERCURY-REDSTONE Mission	5-11
5-4	MERCURY-REDSTONE Booster Flight	5-12
5-5	Off-the-Pad Abort	5-13
5-6	Abort After Liftoff up to Normal Engine Cutoff	5-14
5-7	Preflight Abort Network Schematic Diagram	5-15
5-8	Inflight Abort Network Schematic Diagram	5-16
5-9	Attitude Error Sensor Block Diagram	5-20
5-10	Attitude Error Sensor Circuit	5-22
5-11	Attitude Rate Switch	5-24
5-12	Attitude Rate Switch Block Diagram	5-26
5-13	Attitude Rate Switch Circuit	5-27
5-14	Control Voltage Detector Electrical Schematic	5-29
5-15	Chamber Pressure Sensor	5-31
5-16	MERCURY-REDSTONE Manned Flight Awareness Stamp	5-41
6-1	MERCURY-REDSTONE System Test Flow Diagram	6-2
6-2	Flight Environment of Thrust Unit	6-12
6-3	Vertical Test Fixtures	6-13
6-4	Aft Section Test Summary	6-14
6-5	Location of Instrument Compartment Vibration Transducers	6-19
6-6	General Characteristics of Vibration Measurements (901)	6-20
6-7	General Characteristics of Vibration Measurements (906)	6-21
6-8	Longitudinal Vibration Spectra for MERCURY-REDSTONE Vehicles	6-22

LIST OF ILLUSTRATIONS (CONT.)

<u>Figure</u>	<u>Title</u>	<u>Page</u>
6-9	MERCURY-REDSTONE Flight Sequence	6-25
6-10	Deceleration Parachute Unreefed	6-26
6-11	Release of Deceleration Parachute and Deployment of Final Recovery Parachutes	6-27
6-12	Water Impact	6-28
6-13	Booster Recovery Package	6-32
6-14	Penetration in Inches versus Time in Seconds Showing Close Fit of Sine Curve	6-35
6-15	Accelerations Measured Vertically on MERCURY-REDSTONE Drop Test	6-36
7-1	Launch Site Checkout Scheduling	7-3
7-2	MERCURY-REDSTONE Launch Organization	7-6
7-3	Bar Chart on Vehicle Countdown Status	7-12
7-4	Emergency Egress Time Study	7-37
7-5	Mobile Tower (Cherry Picker)	7-39
7-6	Diagram of Emergency Equipment Location for MERCURY-REDSTONE Launches, Complex 56, Pad 5	7-41
7-7	Service Structure, Pad 5, VLF 56, Cape Canaveral	7-45
7-8	White Room on Level 3, Service Structure, VLF 56	7-47
7-9	Design of Blast Deflector, Service Structure, VLF 56	7-48
7-10	Remote Control Panel, Blockhouse 56	7-49
7-11	Auxiliary Platform, White Room, Service Structure, VLF 56	7-51
7-12	Inverter Panel, Blockhouse 56	7-55
7-13	Environmental Control Panel and Measuring Panel, Blockhouse 56	7-56
7-14	Propulsion and Auxiliary Propulsion Panels, Blockhouse 56	7-57
7-15	Over-all Test Panel, Blockhouse 56	7-59
7-16	Generator and Auxiliary Network Panels, Blockhouse 56	7-60
7-17	Autopilot Rack, Blockhouse 56	7-62
7-18	Test Conductor's Console, Blockhouse 56	7-63
7-19	Capsule Radio Network - UHF	7-65
7-20	Recovery and Rescue Radio Network, High Frequency 30.3	7-66
8-1	MERCURY-REDSTONE MR-1 During Parachute Deployment	8-4
8-2	Liftoff of MERCURY-REDSTONE MR-1A	8-8
8-3	Second Bending Mode Oscillations in Yaw Toward end of MR-1A Flight	8-12

LIST OF ILLUSTRATIONS (CONT.)

<u>Figure</u>	<u>Title</u>	<u>Page</u>
8-4	Liftoff of MERCURY-REDSTONE MR-3	8-19
8-5	MERCURY-REDSTONE MR-3 Capsule Configuration (Capsule No. 7)	8-20
8-6	MERCURY-REDSTONE MR-3 Flight	8-22
8-7	MERCURY-REDSTONE MR-3 Ground Track and Flight Profile	8-22
8-8	MERCURY-REDSTONE MR-3 Acceleration Profile	8-22
8-9	Liftoff of MERCURY-REDSTONE MR-4	8-24
8-10	Flight Profile for MR-4	8-27
8-11	Acceleration Time History for MR-4 Flight	8-27
8-12	Chart of Recovery Operations	8-27

LIST OF TABLES

<u>Table</u>	<u>Title</u>	<u>Page</u>
3-1	MERCURY-REDSTONE Mission Sequence of Events	3-7
4-1	Electrical Power Supplies	4-32
4-2	MERCURY-REDSTONE Booster Flight Telemetry Measurements	4-37
5-1	Flight Failure Analysis of REDSTONE Propulsion System	5-5
5-2	MERCURY-REDSTONE Abort Parameters	5-6
5-3	REDSTONE Attitude Angles and Rates During a Normal Ballistic Trajectory	5-7
5-4	Abort Sensing System Reliability Test Plan A for Attitude Rate Switches, Attitude Error Sensors, and Voltage Detectors	5-34
5-5	Abort Sensing System Reliability Test Plan B for Combustion Chamber Pressure Sensors	5-34
5-6	MERCURY-REDSTONE Reliability Prediction - A	5-36
5-7	MERCURY-REDSTONE Reliability Prediction - B	5-36
5-8	Evaluation of Flight Data on MERCURY-REDSTONE Components	5-38
6-1	Sound and Vibration During Static Firing	6-4
6-2	Propulsion System Test Results	6-16
6-3	Tail Section Test Results	6-17
6-4	Flight Vibration Measurements	6-19
7-1	MERCURY-REDSTONE Mission Rules and Scrub Priority List	7-8
8-1	Summary of the MERCURY-REDSTONE Flight Test Program	8-1
8-2	MR-1 Sequence of Events	8-6
8-3	MERCURY-REDSTONE Priority List of Weak Spots	8-15
8-4	Comparison of Flight Parameters for MR-3 and MR-4 Spacecraft	8-25

SECTION 1

SUMMARY

1.1 GENERAL

This report presents a brief but complete development history of the MERCURY-REDSTONE Project - the United States' first manned launch vehicle. At this time, approximately three years after the last flight of the vehicle, the MERCURY-REDSTONE Project has a continuing significance for manned launch vehicles in that it developed solutions to problems which are still applicable to the systems presently in use or those planned for later development. Such questions as the following must still be answered for each new manned system:

- When is a vehicle ready for manned flight?
- How do we save the astronaut in the event of a failure?
- How do we instill an awareness of the significance of their efforts on reliability and safety to each individual involved in the program?
- How do we provide for ground personnel safety in the event of a failure?
- How do we coordinate and technically integrate the efforts of widely dispersed engineering groups with differing points of view ?

The answers provided by MERCURY-REDSTONE to these questions are described in this report. The lessons to be learned from the failures as well as the success of the project are identified and summarized. In addition, special developments in the program are presented such as the first extensive investigation and test of a booster recovery system.

Section 9 summarizes the major contributions of the MERCURY-REDSTONE Project to manned launch vehicles in the areas of man-rating, design, testing, and operations. In addition, specific equipments were developed which are still applicable for current manned launch vehicle programs. These include the following:

- Emergency egress operations with a mobile aerial tower and an armored emergency rescue vehicle.
- Abort impact predictor for premature mission termination.
- "White Room" enclosing the spacecraft within the launch pad service structure.
- Automatic Inflight abort sensing system.

- Range safety destruct procedures and implementation.
- Prelaunch weather survey techniques.

Other sections of this report present descriptions of the mission, the vehicle design, the man-rating program, development testing, checkout and launch operations, flight testing, and a reference. As a prelude to an orbital flight program, the MERCURY-REDSTONE missions provided an opportunity to check out and evaluate the following:

- Spacecraft systems design.
- Reactions of an astronaut subjected to brief periods of space flight (weightlessness and booster accelerations).
- Launch and recovery operations.
- Manned flights less hazardous than orbital flights.

Suborbital flights provided an excellent simulation of the accelerations imposed on a capsule during its return from orbit even though their duration was not as great.

The mission objectives for the MERCURY-REDSTONE launch vehicle were as follows:

- Familiarize man with a brief but complete space flight experience including:
 - a. Liftoff.
 - b. Powered flight.
 - c. Weightless flight (for a period of approximately 5 minutes).
 - d. Re-entry.
 - e. Landing.
- Evaluate man's ability to perform as a functional unit during space flight by:
 - a. Demonstrating manual control of capsule attitude before, during, and after retrofire.
 - b. Use of voice communications during flight.
- Study man's physiological reactions during space flight.
- Recover the astronaut and capsule.

The adaptation of the tactical missile was made in a series of design changes and modifications based on ground and flight tests. The guideline for conversion of the REDSTONE design and operations to a manned payload were:

- Safety.
- Acceptable human factors.
- No marginal performance.

The implementation of the above guidelines was carried out in three major phases:

- Basic Redesign.
- Modification after Ground Tests.
- Modification after Flight Tests.

1.2 BASIC REDESIGN

A basic redesign was necessary to adapt the REDSTONE to the MERCURY mission. The required modifications and additions made the new launch vehicle physically distinguishable from both the REDSTONE and JUPITER-C as shown in Figure 1-1. To carry out the basic redesign program, the following major areas were considered:

- Increased Performance: Elongation of the REDSTONE propellant tanks, increasing nominal engine burning time from 123.5 to 143.5 seconds.
- Simplicity: Consisted of three major changes:
 - a. Installed simple control system (LEV-3 autopilot), eliminated stabilized platform (ST-80).
 - b. Installed new pressurized instrumentation compartment.
 - c. No separation between aft unit and container section.
- Crew Safety: Addition of an automatic inflight abort sensing system to the booster and emergency egress operations were incorporated at the launch site. Utilization of alcohol as a fuel in lieu of the more toxic Hydine used in JUPITER-C. These were the major provisions in man-rating and are covered in greater detail later in the report.

In all, a total of over 800 changes were made before the MERCURY-REDSTONE Project was completed. The major changes listed above plus many minor changes increased the booster's reliability to the extent that astronaut abort was never necessary.

1.3 MODIFICATION AFTER GROUND TESTS

During the vibration test program, several components failed or were damaged.

These included:

- An engine piping elbow.
- An H₂O₂ bottle bracket.
- The abort rate switch mounting bracket.
- Wires in the roll rate switch.
- An antenna mounting stud.

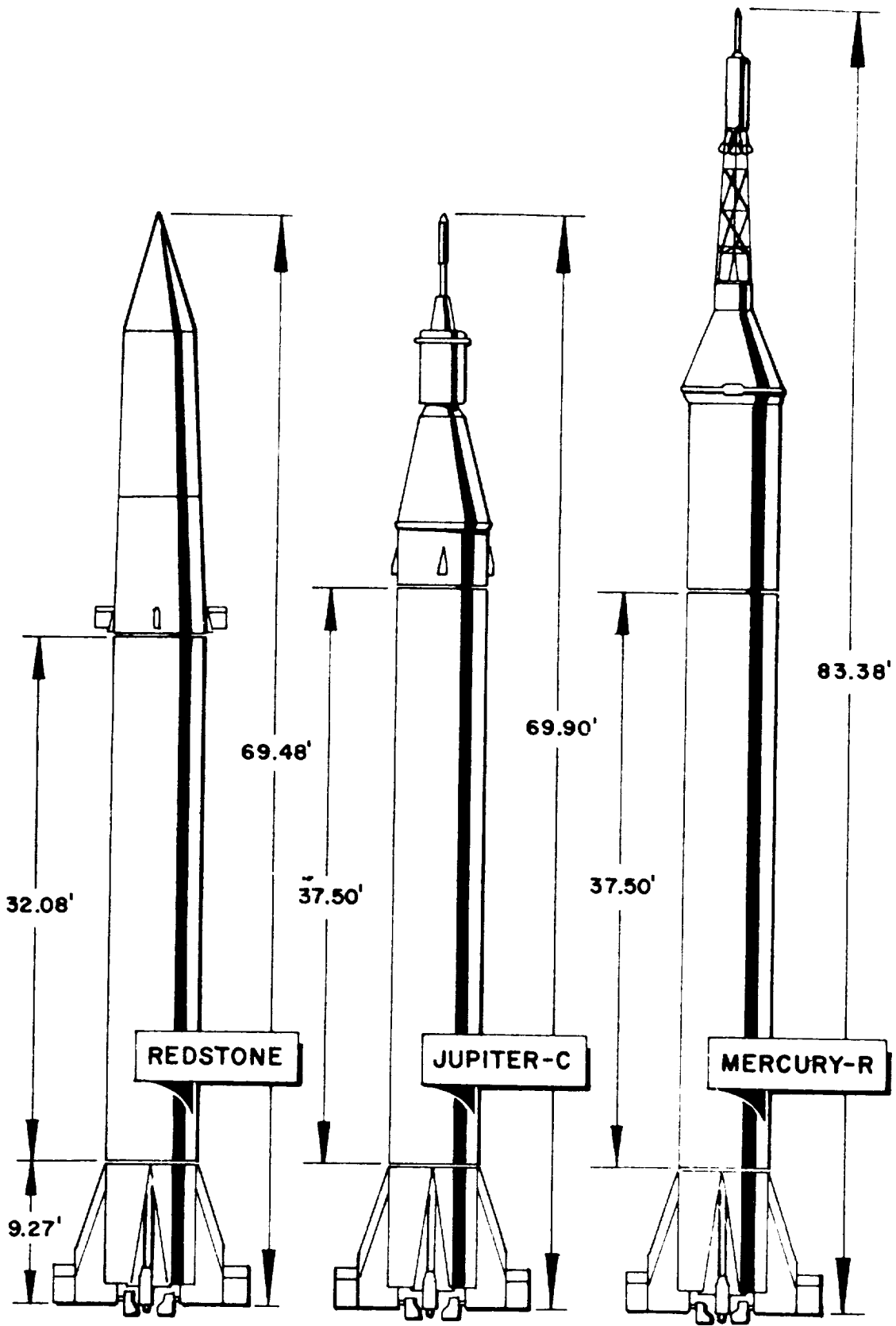

Figure 1-1. The REDSTONE, JUPITER-C, and MERCURY-REDSTONE Launch Vehicles

Similar problems occurred in other components. The success of the modifications proved the value of total system testing. Since the A-7 engine was new, extensive test firings were made. During these firings, combustion instability was discovered to occur at 500 cps. Enlarging the injector holes proved to be the solution. Tracking down the source of another low frequency oscillation eventually led to a study of the static test tower. Modification of the test tower removed this trouble.

1.4 MODIFICATION AFTER FLIGHT TESTS

Problem areas discovered during the flight test program led to the following modifications:

- MR-1 launch attempt proved the need for ground-negative until all other electrical connections were separated. Thus, a one foot ground strap was added.
- A scale factor error due to excessive pivot torque on the LEV-3 longitudinal integrating accelerometer caused MR-1A to experience an excess cutoff velocity of 80 meters per second. Use of softer wire and relocation of five of eight electrical leads solved the problem.
- As a backup to the integrating accelerometer fix, a time-based engine cutoff at 143 seconds was employed on MR-2 and MR-BD. These later flights proved the accelerometer functioned properly, thus use of the cutoff timer was discontinued.
- The thrust controller on MR-2 failed wide-open causing LOX depletion 0.5 second before deactivation of the abort P_c switches. To prevent a similar occurrence on the remaining flights, velocity cutoff arming and switching of the P_c switches to the depletion mode (fuel depletion arming) were separated. Velocity cutoff arming was advanced to 131 seconds to take care of earlier than predicted cutoff velocity, while fuel depletion arming was set at 135 seconds, keeping the combustion chamber pressure abort capability as long as possible, but removing this capability early enough to take care of a high propellant consumption rate.
- Flights MR-1A, MR-2, and MR-BD experienced roll rates approximately twice that of REDSTONE (8 vs 4 degrees per second); however, since the vehicle was not subject to damage at this rate, the roll rate abort sensor was deleted after MR-BD. The roll angle abort limit of 10 degrees was retained.
- An interaction of the second bending mode with the yaw and pitch axis control required the addition of a network filter to reduce control loop gain between 6 and 10 cps. The interaction was noted on flights MR-1A and MR-2.

- Flights MR-1A, MR-2, and MR-BD indicated excessive adapter section vibrations. On MR-3 these were dampened with 340 pounds of a lead impregnated rubber compound added to the bulkhead and walls of the section. Fourteen longitudinal stiffeners were also added to the internal skin surface. Since Astronaut Shepard still noted considerable vibrations during boost on MR-3, an additional 102 pounds of the dampening compound, X-306, were added to the instrument compartment of MR-4

1.5 FLIGHT PROGRAM REVIEW

The MERCURY-REDSTONE Program was originally scheduled for eight flight tests. Only six of the planned flights were attempted, as the success of the program warranted the cancellation of the last two planned flights. Succeeding flights came at intervals of about two months; the interval from the first launch attempt to Astronaut Grissom's flight, covering only nine months (21 November 1960 to 21 July 1961). During this relatively short period the capability of placing man in space was proved and the path charted to full orbital flight. Only the first two MERCURY-REDSTONE flights were originally intended to be unmanned; however, failures caused this number to be increased to four before the two manned flights took place.

The final MERCURY-REDSTONE Program included the following flights: Four developmental (MR-1, MR-1A, MR-2, and MR-BD), and two manned operational (MR-3 and MR-4).

1.6 MR-1 MISSION

The first MERCURY-REDSTONE flight vehicle, MR-1, was launched on 21 November 1960, at 0859 hours EST, at Cape Canaveral (now Cape Kennedy). Its primary mission was to qualify the automatic inflight abort sensing system and the Spacecraft-launch vehicle combination for the MERCURY ballistic mission. The mission included obtaining a velocity of Mach 6.0 during powered boost and successful separation of the spacecraft. After ignition and mainstage only a short vehicle motion occurred. Investigation revealed that a "sneak circuit" through the control plug and ground network gave a premature booster cutoff. The booster settled back vertically on its launch stand after having risen only 3.8 inches. The booster was subsequently deactivated.

As a result of extensive tests, the following changes were incorporated:

- A followup electrical ground line was provided to eliminate the "sneak circuit."

- An "engine pressure switch-missile program device permission circuit" was incorporated to insure reaction to an authentic cutoff signal just prior to 135 seconds after liftoff.

1.7 MR-1A MISSION

Due to problems encountered with MR-1, the second MERCURY-REDSTONE launch was to repeat the first mission, hence its designation MR-1A. The launch occurred at 1115 EST on 19 December 1960. The successful launch of MR-1A was slightly compromised by a malfunction in the integrating gyro, causing cutoff velocity to be higher than normal. This higher velocity caused the capsule to experience maximum re-entry deceleration. A higher than expected mixture ratio was experienced, but a safe margin of propellant remained. Separation rate between the capsule and booster was greater than the value predicted because of the "popgun effect." MR-1A completed its mission with the abort system functioning as expected. All measured abort parameters remained below the maximum tolerable levels.

1.8 MR-2 MISSION

MERCURY-REDSTONE MR-2 was launched on 31 January 1961, at 1145 EST. In the six weeks between the second and third launches, several changes were made. A malfunction of the chamber pressure controller on MR-2 caused the engine to operate at a higher thrust level than expected. This malfunction was the direct cause of the following factors:

- The higher thrust level resulted in a LOX depletion before the normal cutoff circuit was armed.
- When the chamber pressure decayed, an abort signal occurred.
- An additional impulse was given the capsule by the firing of the escape rocket.
- Because the retro rockets did not fire in the abort mode, the capsule experienced high deceleration during re-entry.

These factors combined to cause the capsule to impact beyond the target area. During the first two flights (MR-1 and MR-1A), Range Safety noted that the REDSTONE's steep trajectory caused the missile to remain over land too long for safety, and that the azimuth of 105 degrees was very close to the right-hand impact limit line established by the range.

1.9 MR-BD (BOOSTER DEVELOPMENT) MISSION

The booster development missile (MR-BD) was launched on 24 March 1961, at 1230 EST. The fourth MERCURY-REDSTONE evaluated changes incorporated in the booster after the MR-2 flight test that reduced vehicle oscillations and vibrations and which assured proper velocity cutoff. The second bending mode frequencies again appeared in the angular velocity measurements, but their amplitudes were only one-half of those experienced in the MR-2 flight test. This indicated that the control filter, dampening compound, and stiffeners in the adapter section were effective in reducing the amplitude of the oscillations. The integrating gyro gave cutoff at the proper velocity, indicating that the corrective measures were successful.

1.10 MERCURY-REDSTONE MR-3 MISSION

MERCURY-REDSTONE MR-3, was the first manned flight. With Astronaut Shepard aboard, MR-3 lifted off at 0934 EST on 5 May 1961. All missions assigned to the booster were successfully accomplished and no system malfunction occurred. No evidence of second bending mode feedback in the control system was noted. This further proved the effectiveness of the filter network incorporated after the MR-2 flight test. The astronaut reported buffeting during powered flight, but telemetry data indicated vibration levels were lower than those of the previous MERCURY-REDSTONE flights. However, to lower these vibrations, additional dampening material was added to the instrument compartment prior to the next flight.

1.11 MR-4 MISSION

Concluding the MERCURY-REDSTONE Program was MR-4 carrying Astronaut Grissom in the second successful manned suborbital flight. Again all systems worked properly and all mission objectives were achieved, excepting capsule recovery. As a result of the capsule escape hatch malfunction during recovery, water entered the capsule and increased its weight beyond the capacity of the recovery helicopter. Improved vibration data indicated that the additional dampening material added to the instrument compartment proved effective. The success of MR-4 on 21 July 1961, at 0720 hours, EST, ended the MERCURY-REDSTONE flight program. The first step of "man-into-space" had been accomplished.

A compilation of the milestones of the MERCURY-REDSTONE Project is presented below.

1.12 MILESTONES OF THE MERCURY-REDSTONE PROJECT

1958

- June A Working Group was formed from personnel of the Langley Aeronautical Laboratory and the Lewis Propulsion Laboratory, NACA to consider a man-in-space program.
- September NACA and DOD's Army Research Projects Agency (ARPA) established a Joint Manned Satellite Panel to formulate the plans of the Working Group.
- October The plans of the Panel for a Manned Satellite Program were approved by the Director of ARPA and the Administrator of NASA (NACA became NASA on 1 October 1958). The joint working group and panel then became the Space Task Group and began operations at the Langley Research Center.
- October 6 NASA and the Army Ordnance Missile Command (AOMC) met, and AOMC tentatively agreed to supply 10 Redstone and 3 Jupiter missiles for the program.
- November 3 NASA informed AOMC to proceed with an 8 Redstone missile program.
- November 26 Project MERCURY was officially assigned to the manned-satellite program.

1959

- January 8 NASA funded AOMC for 8 Redstones. The Army Ballistic Missile Agency (ABMA), an element of AOMC, began production planning and scheduling of the MERCURY-REDSTONE Project.
- April 27 Project MERCURY was assigned a "DX Rating," the nation's highest priority rating.

1960

- January 7 The first MERCURY-REDSTONE booster MR-1 was static test fired at ABMA.
- February MR-1 completed its checkout and test program and was stored pending receipt of the first MERCURY capsule.
- June 30 Spacecraft No. 2, the first MERCURY capsule, arrived at ABMA for checkout and booster compatibility tests.
- July 1 The MERCURY-REDSTONE Project was officially transferred from ABMA to the Marshall Space Flight Center (MSFC) of NASA.
- July 20 MR-1 underwent a similar flight test at MSFC.
- August 3 MR-1 and Spacecraft 2 arrived at Cape Canaveral.

- August 22 Erection of MR-1 was completed.
- September 26 After storage to avoid a hurricane, MR-1 was re-erected and the capsule mated.
- November 21 After a third mating of the spacecraft, MR-1 failed during launch. A ground support cable connection caused premature shutdown.
- December 19 MR-1A was successfully launched, providing the first flight test of the MERCURY-REDSTONE.

1961

- January 31 Flight MR-2 (Booster MR-2 and Capsule 5) was successfully launched, carrying the 37-pound chimpanzee "Ham" into space.
- February The decision was made to make one additional booster development (BD) flight before attempting a manned flight.
- March 24 Flight MR-BD was a successful launch, proving the flight worthiness of the booster design improvements. This flight also provided testing of the emergency egress tower and other emergency rescue ground equipments.
- May 5 Flight MR-3 successfully carried Astronaut Shepard in the planned ballistic trajectory; he thus became the United States' first man in space.
- July 21 The second man in space, Astronaut Grissom, was successfully launched aboard Flight MR-4.
- September The MERCURY-REDSTONE Program was phased out.

SECTION 2

INTRODUCTION

The development modification of the first launch vehicle suitable for a manned payload was accomplished in less than two years. During this brief time, the MERCURY-REDSTONE Project team encountered an entirely new scope of design problems in modifying an existing vehicle, the REDSTONE, for its manned payload. Rocket propulsion systems had previously been utilized in manned aircraft such as the German ME-163 and the American X-series of research vehicles (X-1, X-1A, X-2, and X-15); however, the relatively small quantity of propellant on these aircraft and their ability to maintain flight without propulsion indicated that the REDSTONE engineers would be required to resolve significant new problems including the following:

- High explosive yield of propellants.
- Acceleration, noise, and vibration environments.
- Safety for ground personnel and facilities.
- Water recovery of the payload.
- On-pad emergency egress of the astronaut.
- Abort sensing and implementation procedures.
- Abort parameter limits to maximize safety without jeopardizing mission reliability.

The short development time required and the success of the two manned flights (the fifth and sixth launches of the series) are an indication of the dedication and competence which was applied to this task. However, greater tribute to the project is the fact that many of the basic solutions developed in the modification of the REDSTONE for manned flight are valid for present and future launch vehicles (as evidenced by their use in the SATURN/APOLLO Program).

The purpose of this report, then, is to review the MERCURY-REDSTONE Project emphasizing the problems encountered, their resolutions and their implications and applicability to future manned launch vehicles. Often, the items of greatest technical importance which may be useful for succeeding programs is so dispersed among many technical reports that they are retained in a single location only in the memory of a few key project personnel. It is hoped that this report, which points out unique features of the MERCURY-REDSTONE Project, such as the recoverable booster tests as well as the failures and successes of the flight and ground test programs, will serve as a focal

point for guidance of future manned systems project engineers. More detailed information than could be included in this brief report can be obtained from the reports listed in the References, which served as sources for the information presented here.

By early 1959, the performance required of a launch vehicle needed for the first phase of the manned-flight program was determined. The vehicle had to have both the reliability and performance to place a manned, two-ton payload safely into a suborbital trajectory in which at least 5 minutes of weightlessness would be experienced and an apogee of at least 100 nautical miles would be attained. In addition, the vehicle had to be available in time to support the desired flight schedule. These requirements narrowed the choice to launch vehicles which had already been developed for a military mission. Section 3 of this report presents a discussion of the mission and launch vehicle selection.

The REDSTONE, a tactical surface-to-surface missile had been under development and testing for several years prior to its utilization in the MERCURY Program. The first launch of a REDSTONE missile took place on 20 August 1953, almost 8 years prior to the first manned MERCURY-REDSTONE launch on 5 May 1961. During this interim, the basic missile had undergone several development changes and improvements in its design and performance.

At the time of its selection in January 1959 for the MERCURY Program, two versions of the REDSTONE design existed. The first, an advanced model (Block II) of the tactical missile, utilized an improved engine, the A-7, and alcohol and LOX as propellants. The second, the JUPITER-C, was a multistage vehicle utilizing increased capacity tanks compared to the REDSTONE, the Model A-5 engine, and the more toxic Hydine (60 percent UDMH, 40 percent diethylene triamine) and LOX as propellants. This extended performance booster stage was coupled with upper stages of scaled Sergeant solid propellant motors. A four stage version of the JUPITER-C placed EXPLORER I, the free world's first satellite, into orbit.

Since the Block II REDSTONE, the most advanced and reliable version could not meet the MERCURY performance requirements, the configuration selected coupled the Model A-7 engine and propellants of the Block II model with the enlarged capacity tanks of the JUPITER-C. It is interesting to note that by the time of the first manned launch (MR-3), the total reliability of all 69 previous REDSTONE flights was 81 percent; however, the Block II model had achieved 11 consecutive successes and the JUPITER-C had achieved seven consecutive successes.

The REDSTONE, as modified above, satisfied the basic MERCURY Program requirements for the suborbital flight with regard to both performance and availability. However, even though the vehicle had demonstrated a high reliability, it did not incorporate safety features which would prevent the loss of an astronaut in the event of a mission failure. The modification of the vehicle design and launch operations and the development of new quality control and test procedures, necessary for its use as a manned payload carrier, constitute the major technical contributions of the MERCURY-REDSTONE Program to manned launch vehicles. This development, referred to as man-rating, had as its three major guidelines:

- Safety during launch.
- Satisfactory operation within human-factors tolerances.
- Adequate performance margins for mission reliability.

The actual adaption of the vehicle and its operations for manned flight took place in three phases and are treated separately in this report:

- Preliminary modification prior to application.
- Modifications after ground tests.
- Modifications after flight tests.

Although there were hardware changes during the development the basic man-rating program and design concepts did not require major alteration.

The MERCURY-REDSTONE mission was accomplished by the joint participation of the Marshall Space Flight Center (MSFC), then the Development Operations Division of the Army Ballistic Missile Agency (ABMA) with the Space Task Group (STG) of the National Aeronautics and Space Administration (NASA) in the MERCURY Program. Program management was directed by the Space Task Group. At ABMA the MERCURY-REDSTONE Project Office was established to aid in redesigning, modifying, and preparing the REDSTONE to meet the specific MERCURY mission objectives. Coordination panels were set up between McDonnell Aircraft Corporation (MAC), manufacturer of the capsule, and STG and MSFC to coordinate design changes between the three agencies involved in the program. The operation of these panels proved so successful in implementing design and operational integration that they are still the main agency for technical coordination used in the SATURN/APOLLO Program today.

SECTION 3

MERCURY-REDSTONE MISSION

3.1 MISSION OBJECTIVES

By early 1959, several decisions were made in regard to the performance required of a launch vehicle needed for the first phase of the manned flight program. The vehicle had to have both the reliability and performance to place a manned, two-ton payload safely into a suborbital trajectory of 100 nautical miles apogee in which at least 5 minutes of weightlessness would be experienced. In addition, it would have to be available in time to support the desired flight schedule of the later orbital flights with the ATLAS booster. These requirements narrowed the choice to launch vehicles which had already been developed for a military mission.

At this time, two surplus JUPITER-C missiles were available from the Army Ballistic Missile Agency (ABMA). The JUPITER-C was an advanced version of the REDSTONE, a tactical military missile with a record of over 50 successful flights, verifying its reliability. The original REDSTONE could not meet the mission requirements; however, the JUPITER-C had elongated propellant tanks, a lighter structure, and the required performance for MERCURY. The JUPITER-C launch vehicle had been used for conducting re-entry studies and for placing the first United States satellite, EXPLORER I, into orbit.

Therefore, the REDSTONE vehicle, in its JUPITER-C modification, satisfied the basic MERCURY suborbital requirements of availability and performance. However, the JUPITER-C did not incorporate all the necessary safety features, and further adaptation was necessary for its use as a manned launch vehicle. This development, which is sometimes referred to as man-rating, had as its three major guidelines: safety during launch, satisfactory operation from a human-factors standpoint, and adequate performance margins.

To meet performance requirements, use of the elongated JUPITER-C tanks was necessary. These tanks gave the MERCURY-REDSTONE launch vehicle a nominal engine burning time of 143.5 seconds, 20 seconds more than the original REDSTONE vehicle. This greater burning time required the addition of a seventh high-pressure nitrogen

tank to pressurize the larger fuel tank and an auxiliary hydrogen peroxide tank to power the engine turbopump.

To decrease the complexity for the basic MERCURY-REDSTONE three changes were made:

- The REDSTONE stabilized platform (ST-80) was replaced by the LEV-3 autopilot for vehicle guidance. The LEV-3 system was less complex, more reliable, and met the guidance requirements of the MERCURY-REDSTONE mission.
- The aft unit, containing the pressurized instrument compartment and adapter were permanently attached to the center tank assembly. In the tactical version, this unit separated with the payload to provide terminal guidance.
- A short spacecraft adapter, including the spacecraft launch vehicle separation plane, was supplied by the spacecraft contractor. This arrangement simplified the interface coordination.

For the MERCURY-REDSTONE launch vehicle, alcohol was chosen as fuel. Although the JUPITER-C had used unsymmetrical diethyltriamine (UDETA) for greater performance, its toxicity was higher than that of alcohol and was considered to be undesirable for manned flights. However, the selection of alcohol led to a problem with the jet control vanes because the extended burning time caused greater erosion of these vanes. Hence, a program was initiated to select jet vanes of the highest quality for use in MERCURY.

To provide for maximum crew safety, an automatic inflight abort-sensing system was added to the launch vehicle and an emergency egress operation was established for the launch complex. These factors were primary considerations in man-rating the REDSTONE.

The MERCURY-REDSTONE was aerodynamically less stable than the standard REDSTONE. Because of the unique payload characteristics and the elongated tanks, the MERCURY-REDSTONE was expected to become unstable in the supersonic region approximately 88 seconds after liftoff. To compensate for this instability, 687 pounds of ballast were added forward of the instrument compartment.

Changes were also necessary because of the decreased lateral bending frequencies. The configuration and payload changes reduced the MERCURY-REDSTONE bending

frequencies to one-fourth those experienced by the standard REDSTONE. As a result, resonance problems appeared during both ground and flight testing, and the second bending mode had to be filtered out of the control system to prevent feedback.

3.2 FLIGHT TRAJECTORY

The trajectory for the MERCURY-REDSTONE mission was based on the performance predicted for the booster vehicle's modified propulsion system. Included in the calculations were the thrust available during all phases of flight including thrust buildup at launch after liftoff and during the final decay subsequent to engine shutdown. Longitudinal forces derived from the expected upper atmosphere winds were also included. All attitude references were made with respect to the launch vertical. Figures 3-1, 3-2, and 3-3 are typical curves for dynamic pressure, velocity, and acceleration versus time for the MERCURY-REDSTONE mission.

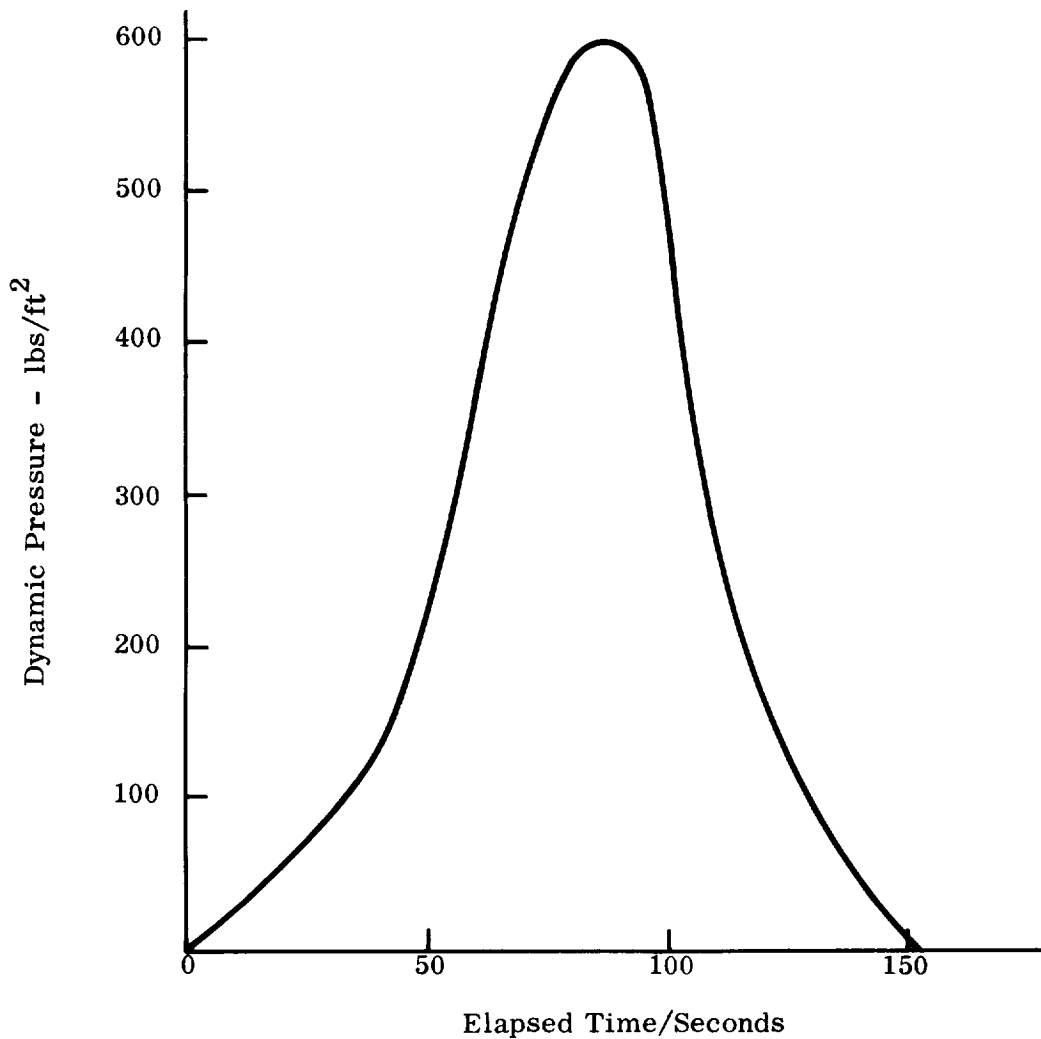

Figure 3-1. Dynamic Pressure During Boost, MR-4 Mission

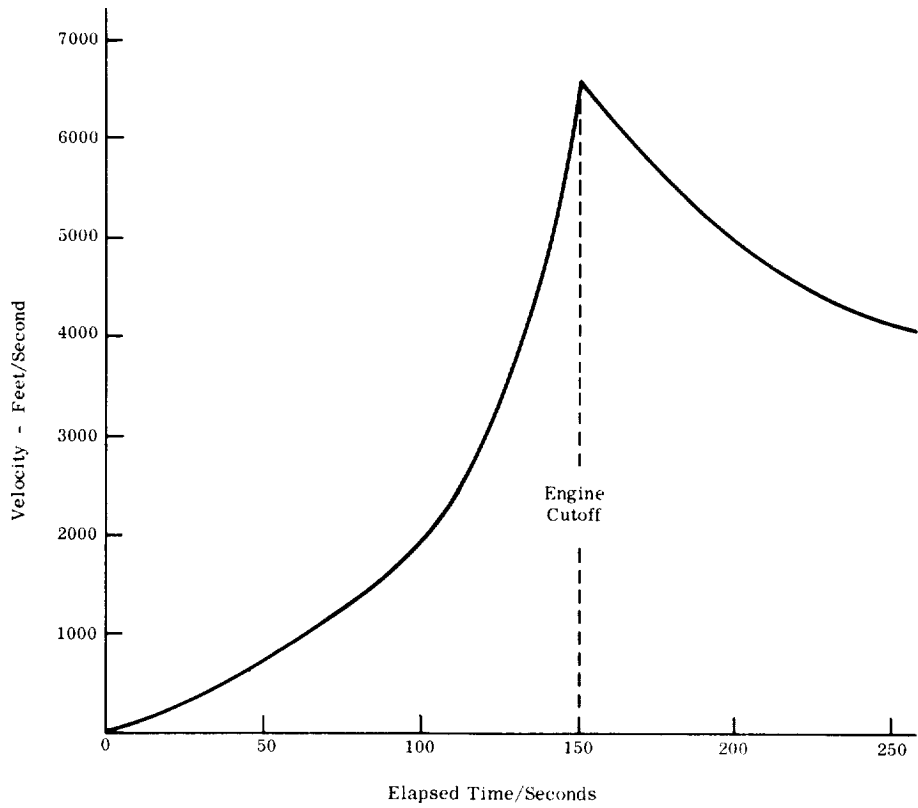

Figure 3-2. Velocity During Boost, MR-4 Mission

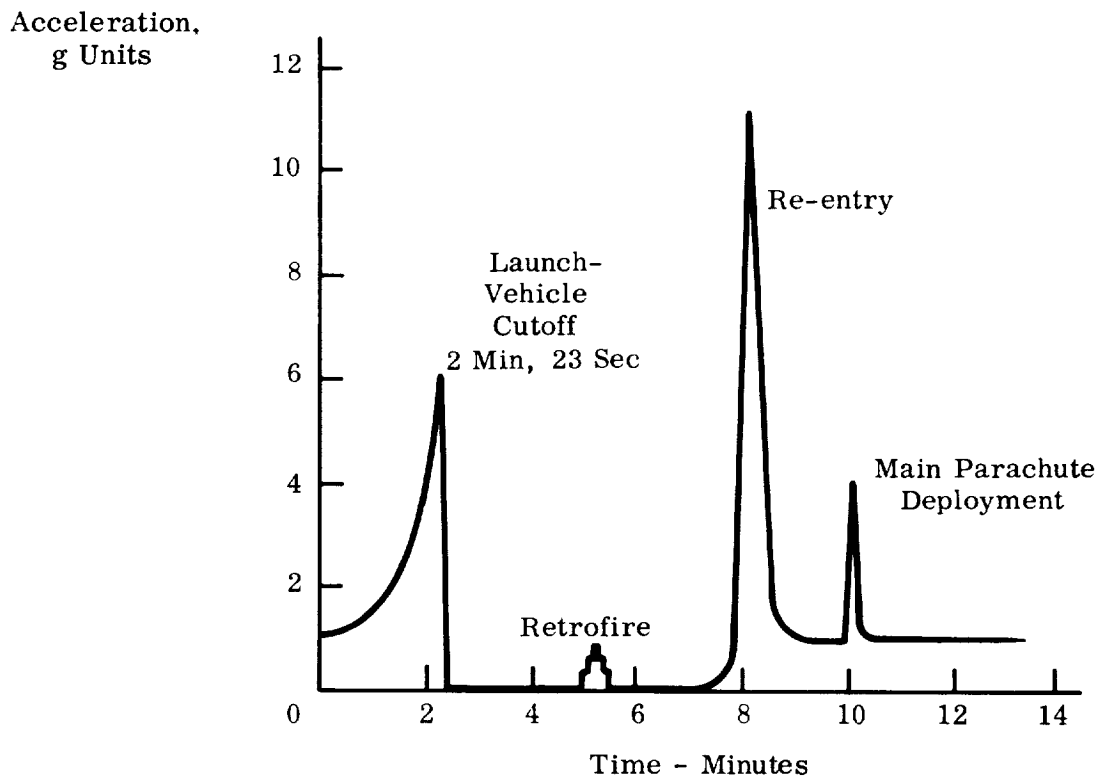

Figure 3-3. Axial Acceleration versus Time, MR-4 Mission

Many aerodynamic studies were undertaken to ascertain the normal loads on the vehicle which could have some immediate influence on the shaping of the trajectory of vehicle structural or control design. Other considerations were involved with trajectory shaping. These included the tilt program design with respect to the time over land in the Cape area.

The vehicle's flight path remained over the Cape area for the first thirty seconds following liftoff and presented a difficult situation for range safety. During this time, the abort system was not permitted to shut down the engine, thus reducing the probability of an early mission abort resulting in a hazardous condition for ground personnel and equipment.

Range safety considerations also played an important role in determining the specified trajectory limits. The original azimuth selection of the 105 degrees east of north was made from the standpoint that no other pads were along the flight path. This launch azimuth was later changed to 102 degrees after the MR-1A launch. The MR-4 mission was launched at 100 degrees azimuth. (See Section 8.)

3.3 MISSION PROFILE AND SEQUENCE OF EVENTS

The MERCURY-REDSTONE launch profile injected the MERCURY capsule in a sub-orbital flight at a nominal, earth-fixed velocity of 6500 feet per second. The injection angle was 41.80 degrees, cutoff altitude 200,000 feet, and Mach number 6.3. The maximum acceleration at engine cutoff was 6.3 g's.

In Table 3-1, several important booster sequencing points are indicated. Thirty seconds after liftoff a circuit was activated permitting automatic engine cutoff prior to abort. Prior to this time, only the range safety officer could initiate an engine shutdown. At 129.5 seconds the normal shutdown circuitry was armed. This prevented early jettisoning of the escape tower. At 131 seconds the velocity cutoff accelerometer was armed. This occurred twelve seconds before nominal cutoff to allow for higher than nominal performance or for off-nominal propellant mixture ratio and subsequent early propellant depletion. For the same reasons, the chamber pressure abort switches were deactivated at 135 seconds, thus preventing an abort at normal cutoff. Both cutoff activation and pressure switch deactivation were originally scheduled to occur at 137.5 seconds, but as a result of the early shutdown of MR-2, the indicated times were selected for all subsequent flights. Figure 3-4 shows a typical flight profile.

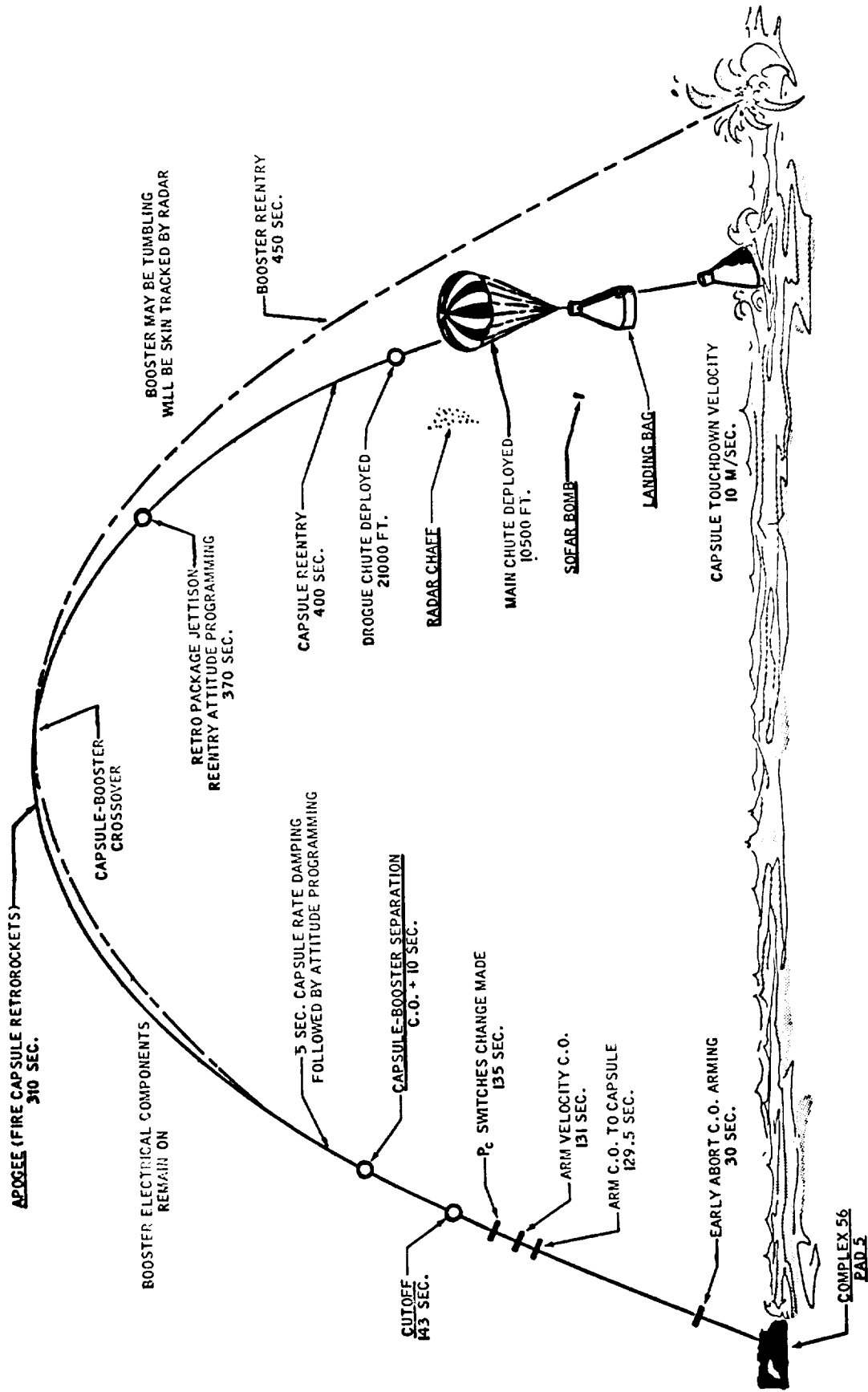

Figure 3-4. Typical Flight Profile, MERCURY-REDSTONE

At shutdown (143 seconds), the abort system was deactivated and the escape tower jet-tisoned. This occurred 9.5 seconds before capsule separation. Figure 3-5 is a block diagram of the MERCURY-REDSTONE mission sequence.

Table 3-1

MERCURY-REDSTONE Mission Sequence of Events

Event	Time After Liftoff (Seconds)
Liftoff	0
Begin tilt program (MR-1, -IA, and -2)	24.3
(MR-BD, -3, and -4)	15.0
Arm circuit for engine cutoff by abort system	30.0
Stop fuel tank pressurization	70.0
Special tilt arrest (MR-BD only) for 8 seconds	78
Arm cutoff circuit to capsule	129.5
Arm velocity integrator cutoff circuit	131.0
Tilt program arrest	131.7
Arm fuel depletion cutoff circuit (chamber pressure sensing switches changed to fuel depletion mode)	135.0
Nominal cutoff time (initiated by velocity integrator)	142.5
Escape tower separation and abort system deactivation	143.0
Capsule separation	Cutoff +9.5
Nominal maximum altitude (booster)	308.7
Nominal maximum altitude (capsule)	309.1
Nominal capsule re-entry, maximum deceleration	492.0
Nominal capsule main parachute unreefed	618.0
Booster impact (MR-3 only)	674.0
Capsule impact (MR-3 only)	922.0

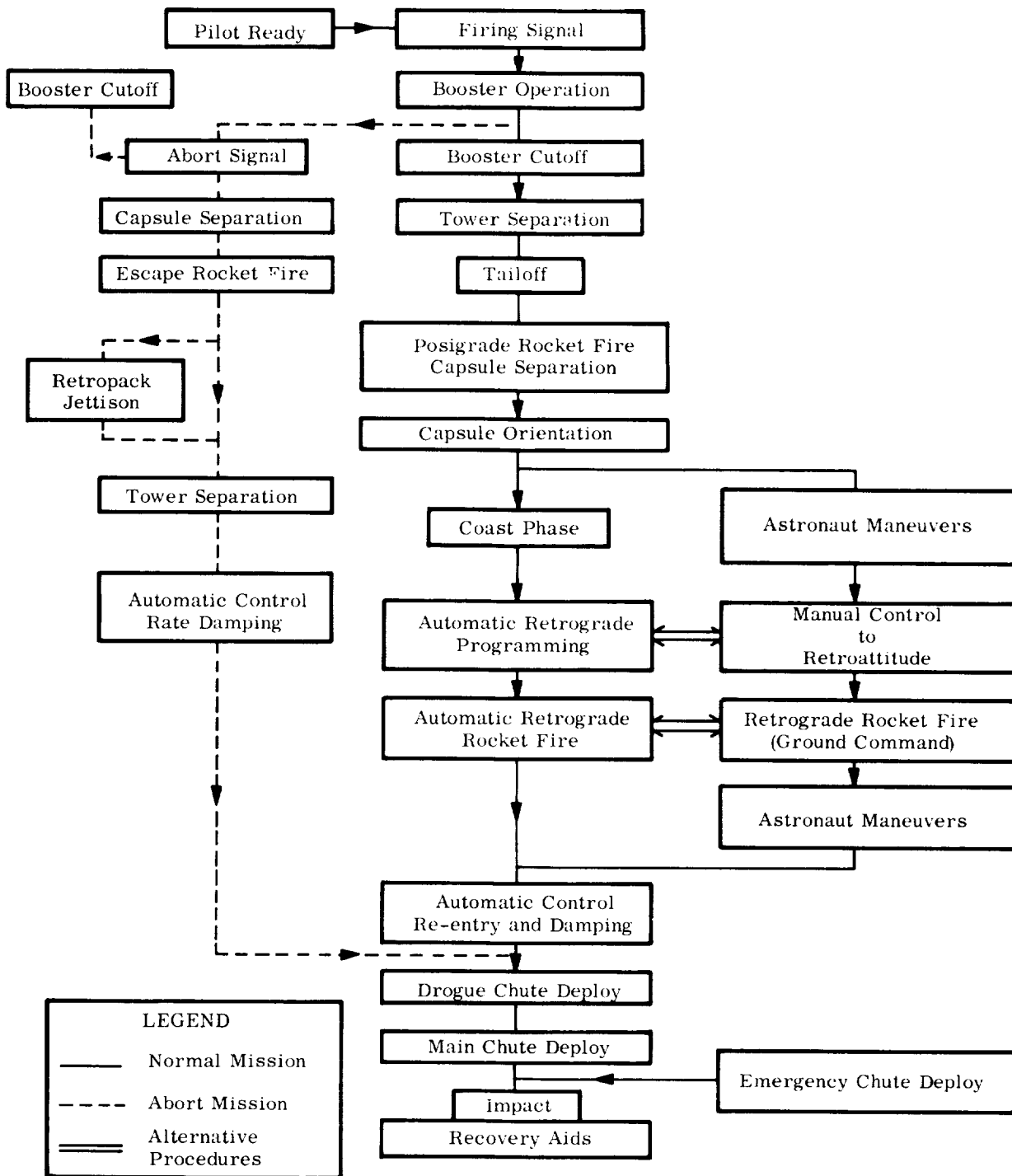

Figure 3-5. Block Diagram of MERCURY-REDSTONE Mission Sequence

SECTION 4
VEHICLE DESCRIPTION

4.1 INTRODUCTION

The over-all 83.38-foot length of the MERCURY booster was made up from several booster units, shown in Figure 4-1. These units and the systems contained within them are described in this section.

4.2 STRUCTURE

4.2.1 GENERAL

The basic vehicle was primarily constructed with 5052 aluminum alloy using a semi-monocoque skin and a ring frame design with stringer longerons for additional support in the aft and tail units. Figure 4-2 shows the structure in an exploded view. The design factor of safety was 1.35 on the propellant tanks.

The structural weights were:

● Aft Section	437.4 lb
● Center Section	1659 lb
● Tail Section	902.6 lb
● Ballast	487 lb
● Dampening Compound	442 lb
● Blast Shield	15 lb

With airborne equipment installed, the total booster dryweight was 8195 pounds.

4.2.2 CENTER SECTION

The thrust load was transmitted from the engine to the center section by a four-strut frame. The skin of the center section was designed to transmit this load to the aft unit without stringers or pressurization. The aft unit, a name carried over from the tactical version, was attached to the forward end of the center or container unit with six fasteners in compression. The tail unit was attached to the container unit by 12 fasteners in tension.

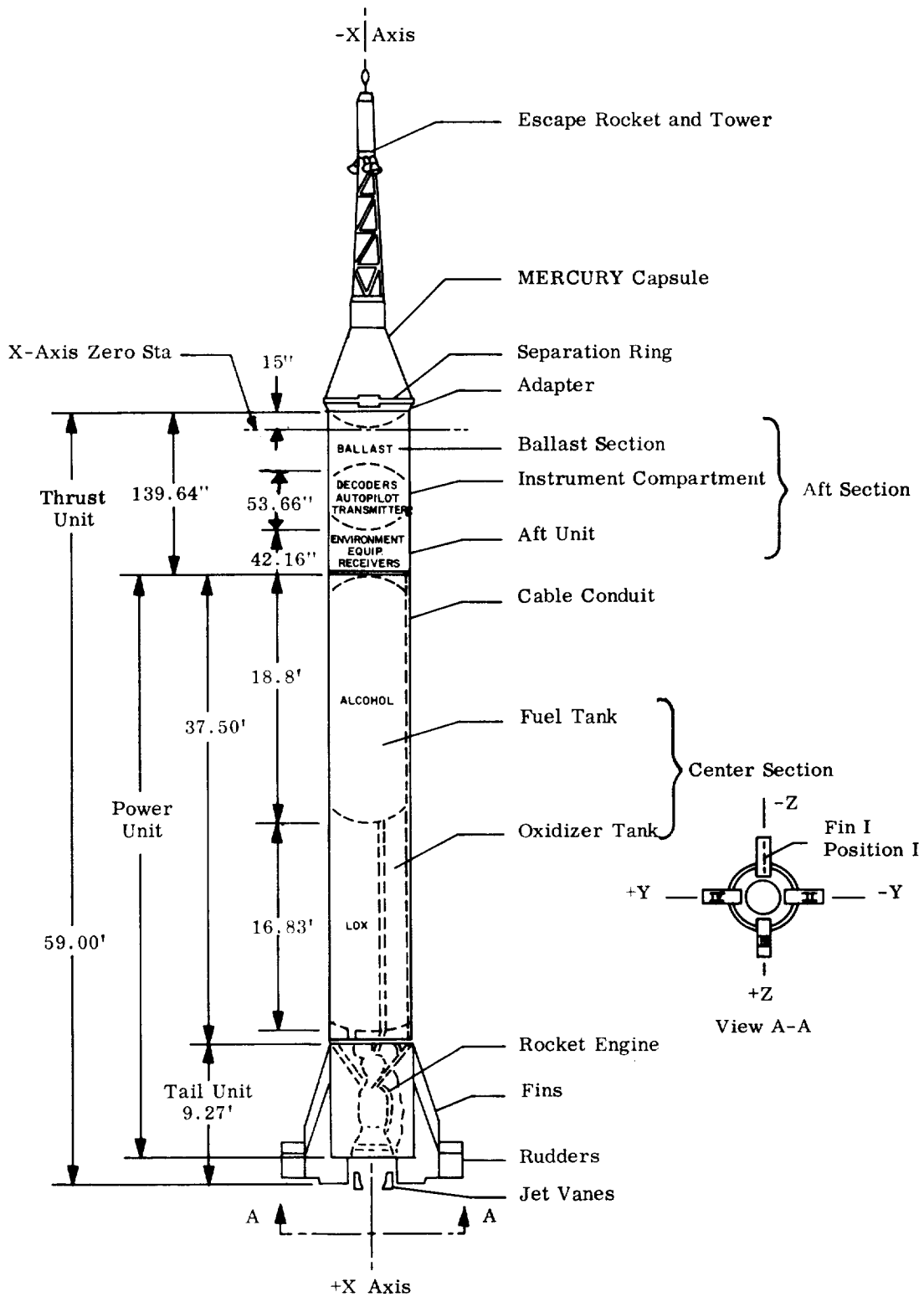
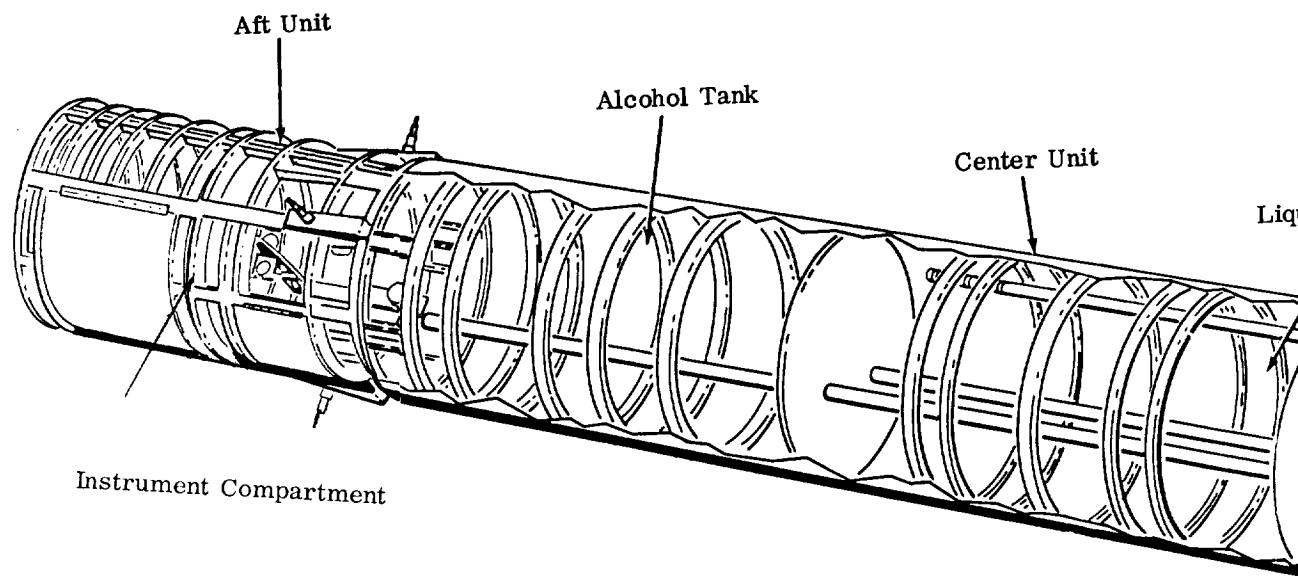

Figure 4-1. Booster Units



d Oxygen Tank

Rocket Engine

Tail Unit

Carbon Jet Vanes (4)

Air Rudders (4)

Figure 4-2. Exploded View of Launch Vehicle Structure

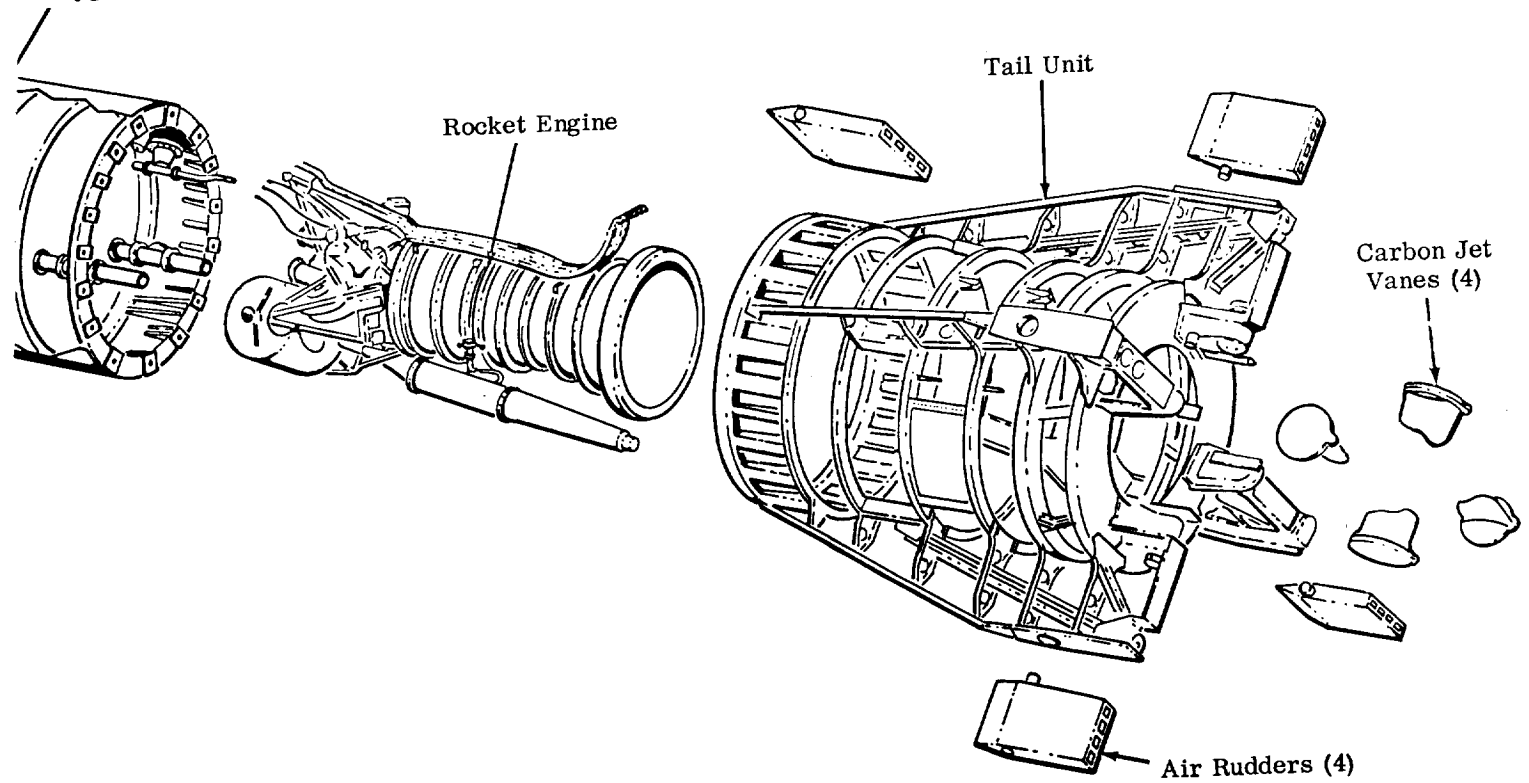

Skin thickness was 0.090 inch on the aft unit, 0.063 inch on the fuel tank, 0.080 inch on the LOX tank, and 0.125 inch on the tail unit. Glass wool was used to insulate the LOX tank bulkheads and the fuel feed line, which passed through the LOX tank.

The forward bulkhead of the center section was designed to withstand 25.3 psi during flight. The center bulkhead was common to both tanks and was designed for a minimum burst pressure of 95 psid (differential pressure) in the fuel to oxidizer direction. The bulkhead could also withstand 55.6 psid in the oxidizer to fuel direction without buckling. Burst pressure of the aft bulkhead was 90 psid. Nominal fuel tank pressure was 18.5 psig, vented at 22 ± 5 psig. Nominal oxidizer tank pressure was 19.5 psig, vented at 32 ± 1 psig. Nominal fuel volume was 3348 gallons, and nominal oxidizer volume was 3072 gallons.

4.2.3 AFT SECTION

Forward of the container section was the 139.64-inch-long aft section. Positioned in the center of the aft section, and 53.66 inches in length, was the pressurized instrument compartment. The ballast section was above the compartment, and below it was the aft unit containing the nitrogen pressurizing system and communication antennas and receivers.

The instrument compartment had four access doors and was both pressure and temperature controlled. Located in the compartment were instrumentation and power supplies associated with the control system, the vehicle's electrical system, the telemetry system, the abort system, and the command destruct system. These instruments were mounted on a T-shaped structure consisting of two plates at right angles to each other.

Compartment pressurization was maintained between 12 and 15 psia during flight by a check-valve controlled nitrogen gas system. During preflight checkout, the electronic equipment within the compartment generated approximately 3.5 kilowatts of heat, thus an 80 cfm air cooling system was required to maintain compartment temperature between 10° and 40° C.

Temperature was controlled by removing air from the instrument compartment through the missile drop-off plate, regulating the temperature of this air by means of a cooling

package mounted on a cable mast, and returning the cooled air to the compartment through a balanced distribution system. Regulation of the air temperature was affected by a temperature sensor control valve, which varied the air flow through the cooling package. Components of this system were the coolant container, blower, check valve, vent valve, control box, air temperature sensor, ducting dehumidifier, three-way valve, and thermostats.

4.2.4 TAIL UNIT

The tail unit consisted of the cylindrical section surrounding, but not including, the rocket engine. The air rudders and jet vanes were also parts of the tail unit. This unit was designed to support the entire launch vehicle while standing freely on the launch pedestal. The MERCURY-REDSTONE did not use hold down arms during launch.

Inside each fin and attached to the tail unit was a servomotor used to rotate the jet vane and air rudder. The servomotor was driven by electrical signals from the control computer located in the instrument compartment. Located within the upper portion of the tail unit were seven spheres containing high pressure gases for tank pressurization. The tactical missile had two sets of three tanks each. However, a seventh tank had to be added during the MERCURY-REDSTONE modification program to provide pressurization throughout the increased burning time of the engines.

Two hydrogen peroxide tanks used in the propulsion system were also located in this area. The second or auxiliary tank was also added because of the lengthened burning time.

Two connectors were located on the bottom of Fin II for mechanical and electrical power connections and grounding of the vehicle through the launch pedestal. These connections were the last ground-vehicle connections to be detached as the missile lifted off.

4.2.5 ADAPTER AND CAPSULE INTERFACE

The adapter was a conical section bolted to the aft unit which provided the interface between the launch vehicle and the capsule. The capsule was attached to the booster adapter with the capsule adapter-clamp-ring retaining device. The clamp ring secured the lower edge of the capsule to the upper edge of the adapter. The ring had three segments which were fastened together by explosive bolts. The bolts were wired

separately to provide redundant ring cutting. Each bolt was covered by a shield to prevent fragments of the severed bolt from striking the capsule or booster.

To assure proper electrical continuity between the adapter and the capsule, interface templates were used to mount two electrical plug connectors.

The physical separation of the booster and capsule was accomplished by firing the capsule's posigrade rockets. However, to be effective, the booster had to be in the cutoff condition with little, if any, residual thrust. Zero thrust was to be expected about 3.2 seconds after booster engine cutoff. Residual thrust from the LOX venting did not interfere with the separation since the LOX vented at low force and in a direction perpendicular to the longitudinal axis of the vehicle. The posigrade rockets, which extended into the ballast section, fired into the upper end of the aft unit and filled the ballast section with gas. The gas pressure further helped the separation by pushing the capsule away from the booster. The Lewis Research Center, NASA, conducted tests and determined that this gas increased separation velocity by approximately 25 feet per second.

4.3 PROPULSION SYSTEM

4.3.1 GENERAL

The propulsion system was composed of the rocket engine, propellant feed system, and the hydrogen peroxide and pneumatic subsystems. These were contained within the tail unit and attached to the container section by four thrust struts. The propulsion system and flight control at the beginning and end of the thrust period was achieved by deflection of carbon vanes inserted into the exhaust of the engine.

The subsystems and components of this system are described in the following paragraphs.

4.3.2 ROCKET ENGINE

The Rocketdyne Model A-7 engine (Figure 4-3) was the powerplant for the MERCURY-REDSTONE launch vehicles. Basically it was the same powerplant as used in the latest tactical REDSTONE missiles with modifications to improve operational efficiency and safety. The engine generated 78,000 pounds of thrust at sea level. The propellants used were ethyl alcohol and liquid oxygen. The turbopump was driven by hydrogen peroxide.

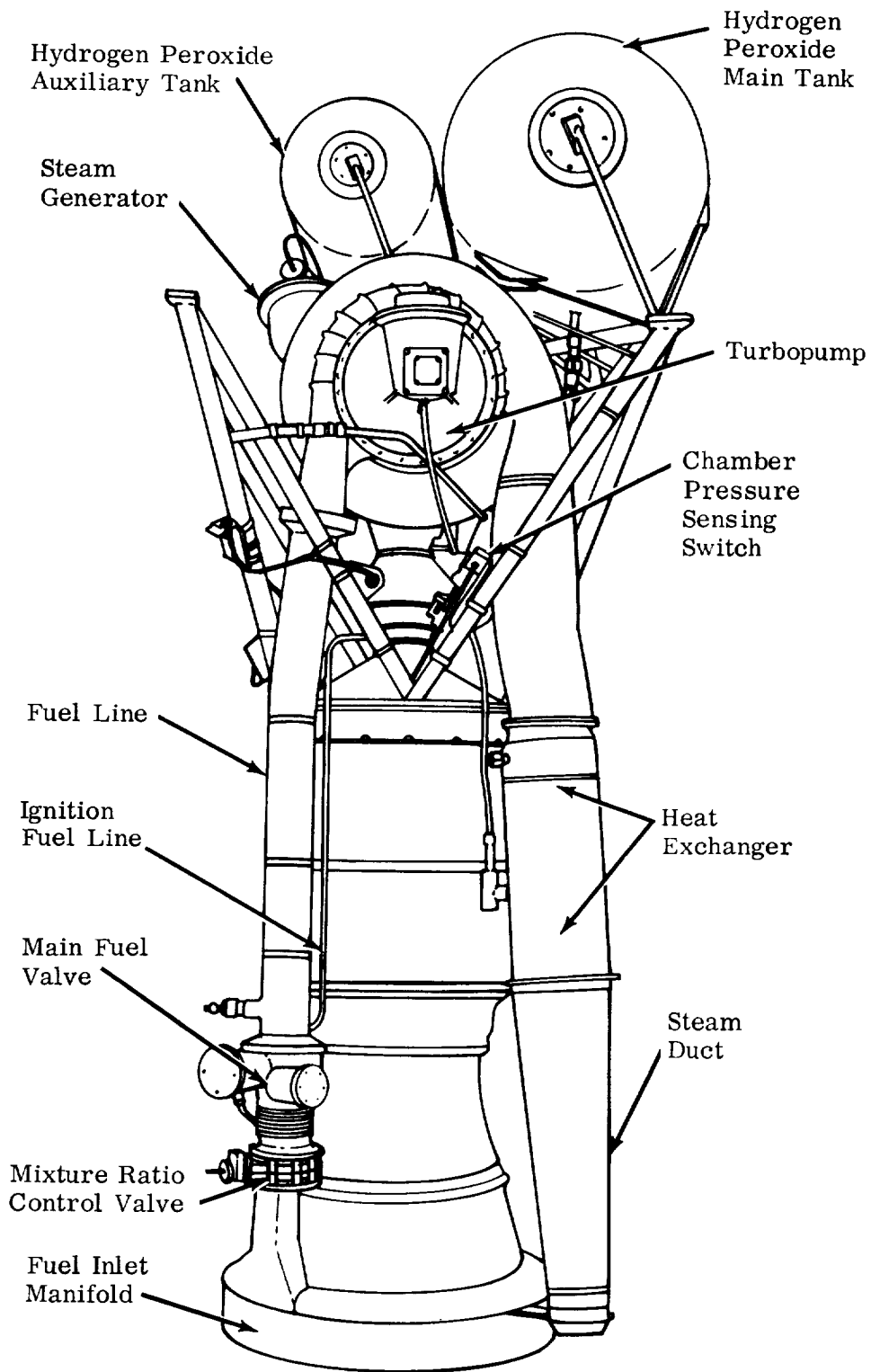

Figure 4-3. A-7 Rocket Engine

The engine starting sequence was initiated from a ground source by a manual firing command signal. Figure 4-4 illustrates the main actions leading to mainstage burning. Liftoff occurred when approximately 85 percent of rated thrust was attained.

The thrust level of the engine was maintained at a specific magnitude by a thrust control system, which compared the actual thrust chamber pressure with a preset electrical null and regulated the flow of hydrogen peroxide into the gas generator. By controlling the flow of peroxide for producing gas the speed of the turbopump controlled the amount of propellants entering the thrust chamber.

Once started, engine operation normally continued until the vehicle had reached a predetermined velocity. When this velocity was attained, an integrating accelerometer emitted a signal that initiated an automatic cutoff sequence (Figure 4-5). This sequence consisted essentially of closing the peroxide, main LOX, and fuel valves to stop the engine. As pressure in the thrust chamber decreased, a signal started a timer in the capsule which ultimately triggered capsule separation.

4.3.3 PROPELLANT FEED SUBSYSTEM

The propellant feed subsystem delivered propellant to the engine at the required pressures and flow rates. The system also included provisions for ignition fuel control.

From their tanks, LOX and fuel passed through the turbopump, main valves, and control orifices to the engine. The turbopump consisted of a steam driven, two stage, compound turbine; a geared speed reduction unit; and two centrifugal propellant pumps. Both pumps operated at the same speed. The turbine ran at a nominal 4800 rpm. Maximum safe speed was 6000 rpm. Minimum allowable fuel inlet pressure was 16 psig, and minimum oxidizer inlet pressure was 23 psig.

During ignition, LOX at tank pressure plus static head was mixed in the combustion chamber with pressure-controlled ignition fuel from an external ground supply. This method resulted in a controlled oxidizer-rich ignition.

4.3.4 HYDROGEN PEROXIDE SUBSYSTEM

The hydrogen peroxide subsystem drove the turbopump. Hydrogen peroxide concentrated to 75 percent was fed at 1.28 pounds per second from the H_2O_2 tanks to the steam generator where it was chemically decomposed into steam. The steam at approximate

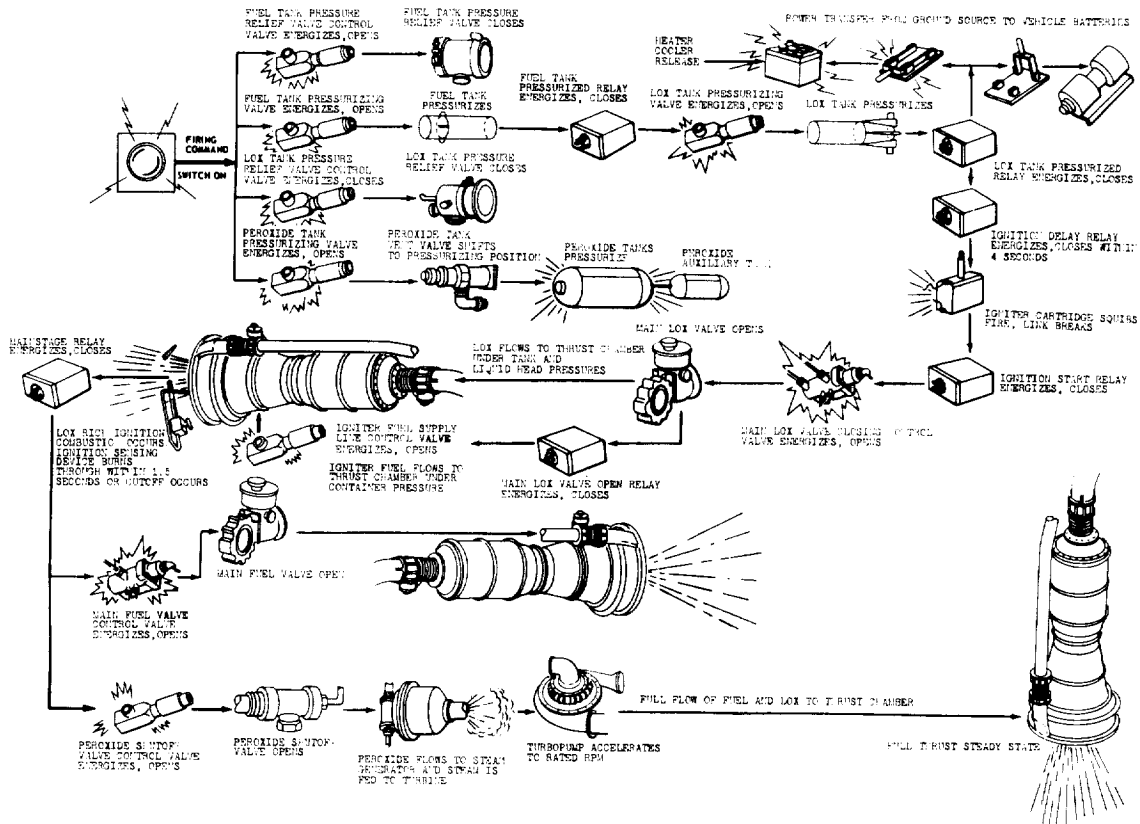

Figure 4-4. Engine Starting Sequence Diagram

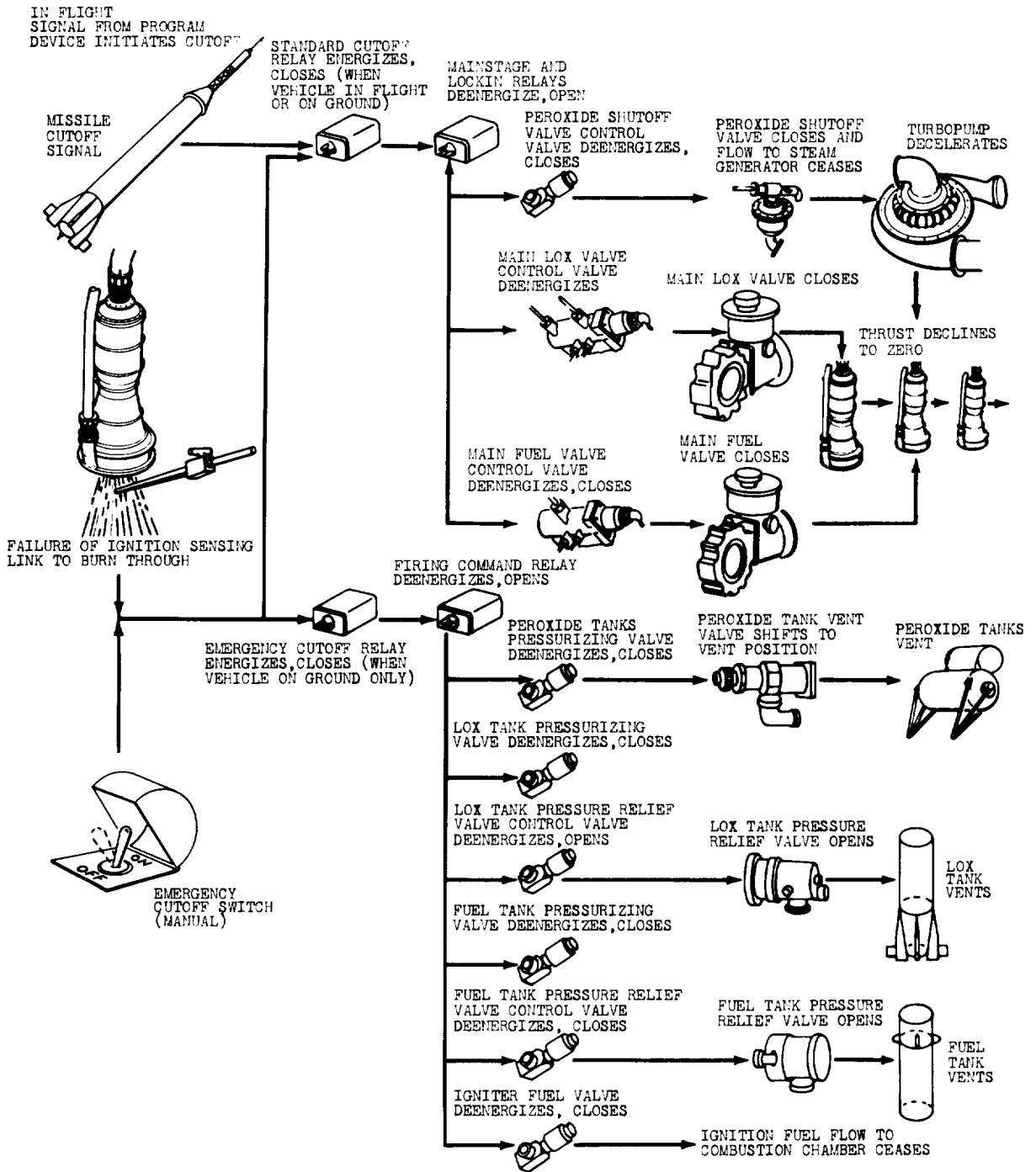

Figure 4-5. Engine Cutoff Sequence Diagram

740° F and 385 psi, was passed through the turbopump, and exhausted through the LOX and pneumatic system heat exchanger.

4.3.5 PNEUMATIC CONTROL SUBSYSTEM

The pneumatic control subsystem (Figure 4-6) provided gaseous nitrogen, at a nominal 580 psi, to operate propellant and peroxide valves and to pressurize the peroxide tanks. A tap on the system provided preflight and inflight fuel tank pressurization. LOX tank pressurization and control were also maintained during preflight by gaseous nitrogen, but inflight pressurization was maintained by LOX converted to gaseous oxygen in the heat exchanger. Prior to liftoff, a ground source of pressurized gaseous nitrogen operated the subsystem and supplied nitrogen for the tail section purging (to remove moisture and any volatile gas accumulations) and for fuel line bubbling (to keep the fuel temperature above freezing).

4.4 CONTROL SYSTEM

4.4.1 GENERAL

The MERCURY-REDSTONE Launch Vehicle control system maintained the proper attitude of the vehicle throughout the flight. This was accomplished by establishing and maintaining three reference axes and indicating, through error voltages, any deviation from the programmed flight. The two major gyros were the pitch gyro and the yaw-roll gyro. An integrating accelerometer (gyro type) gave a cutoff signal to the propulsion system when the predetermined velocity had been attained.

Carbon jet vanes located in the exhaust of the propulsion unit, coupled with the air rudders, were utilized to control the attitude of the vehicle. At liftoff, the jet vanes deflected the hot exhaust gases of the rocket to provide control and stability until the vehicle gained sufficient speed for the air rudders to become effective. Later, when the vehicle reached the rarified upper atmosphere and the rudders lost their effectiveness, the jet vanes again exerted the greater controlling influence.

Figure 4-7 illustrates the operation of the system in block diagram form. As shown, the system was composed of the LEV-3 stabilizer system control computer, control relay box, program device, flight sequencer, and four electro-mechanical actuators with feedback.

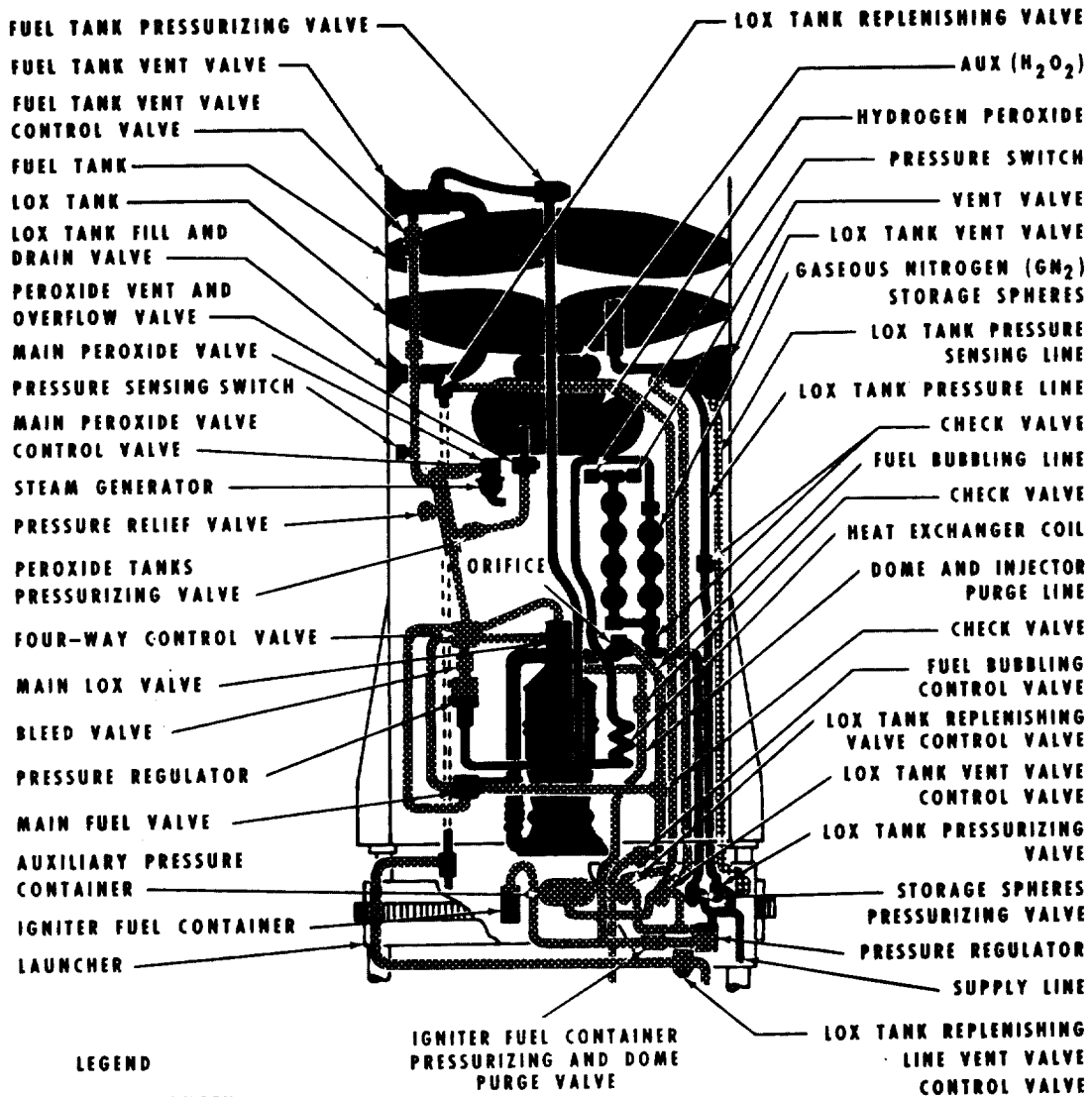

Figure 4-6. Pneumatic System

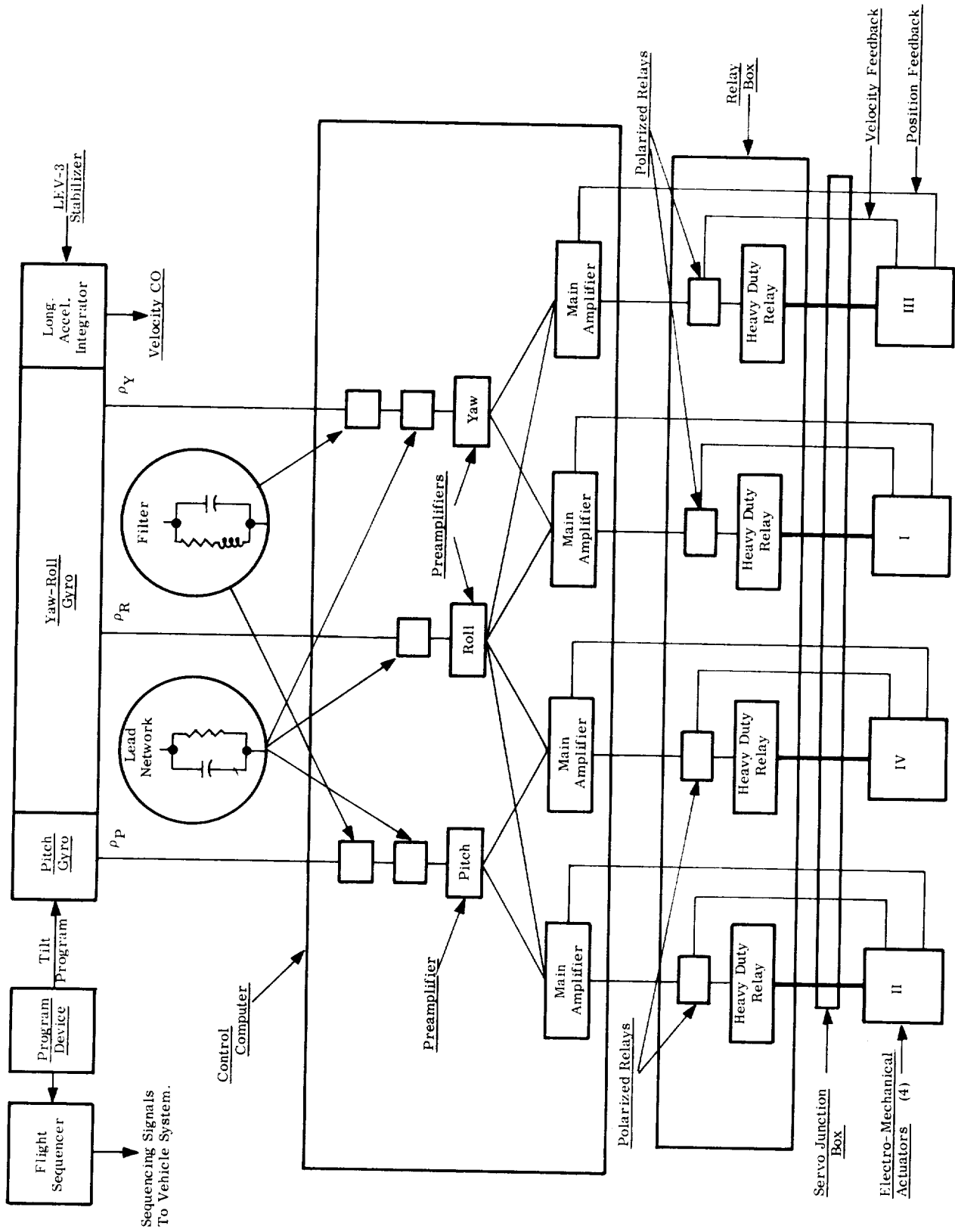

Figure 4-7. Details of Booster Control System

4.4.2 SYSTEM OPERATION

The control system was essentially an autopilot. It did not navigate nor guide the vehicle, but provided the necessary attitude program. During the powered phase of flight from 24 seconds to 131.5 seconds after liftoff, the tilting of the vehicle was controlled by the LEV-3 pitch gyro. Figure 4-8 shows diagrammatically the operation of the pitch gyro and the plane in which tilting occurred. The program device fed a continuous series of pulses to the stabilization system, causing the zero position of the pitch potentiometer to shift. The control system, recognizing this shifting zero point as an attitude error signal, caused the vehicle to tilt over until the wiper on the potentiometer was aligned to the new zero. The pitch programming was the means by which the vehicle was made to align its longitudinal axis with the gravity turn trajectory in order to fly without angle of attack measurement.

Tilt angles of only whole degrees, or multiples thereof, were possible. The minimum time required between tilting pulses for single tilting steps of one degree was set to allow a desired tilting rate of 0.67 degree per second. Figure 4-9 shows the pulse program for tilting.

A velocity integrator was used to signal engine thrust cutoff when the proper vehicle velocity was reached. The integrator, a gyro precessed by the gravitational and vehicle acceleration fields, sent the cutoff signal through pickoffs when the calibrated precession angle was reached.

4.4.3 LEV-3 STABILIZER SYSTEM

The LEV-3 stabilizer system (Figure 4-10) consisted of pitch and yaw-roll gyros, an integrator gyro within a junction box, and a shock mounted, gimbaled baseplate. The system provided the reference frame from which vehicle attitude and acceleration were measured.

The two attitude gyros established and maintained three mutually perpendicular reference axes from which vehicle deviations in pitch, yaw, and roll were measured by means of potentiometer pickoffs. The pitch potentiometer was not fixed but was mechanized to the program device (refer to paragraph 4.4.2.) The rotor of each gyro was also the rotator of a synchronous motor, driven by a 400 cps power source; the synchronous motor's rotating field (stator) had an equivalent angular velocity of 24,000 rpm. Slip between the stator and rotator was 2000 rpm, resulting in a gyro

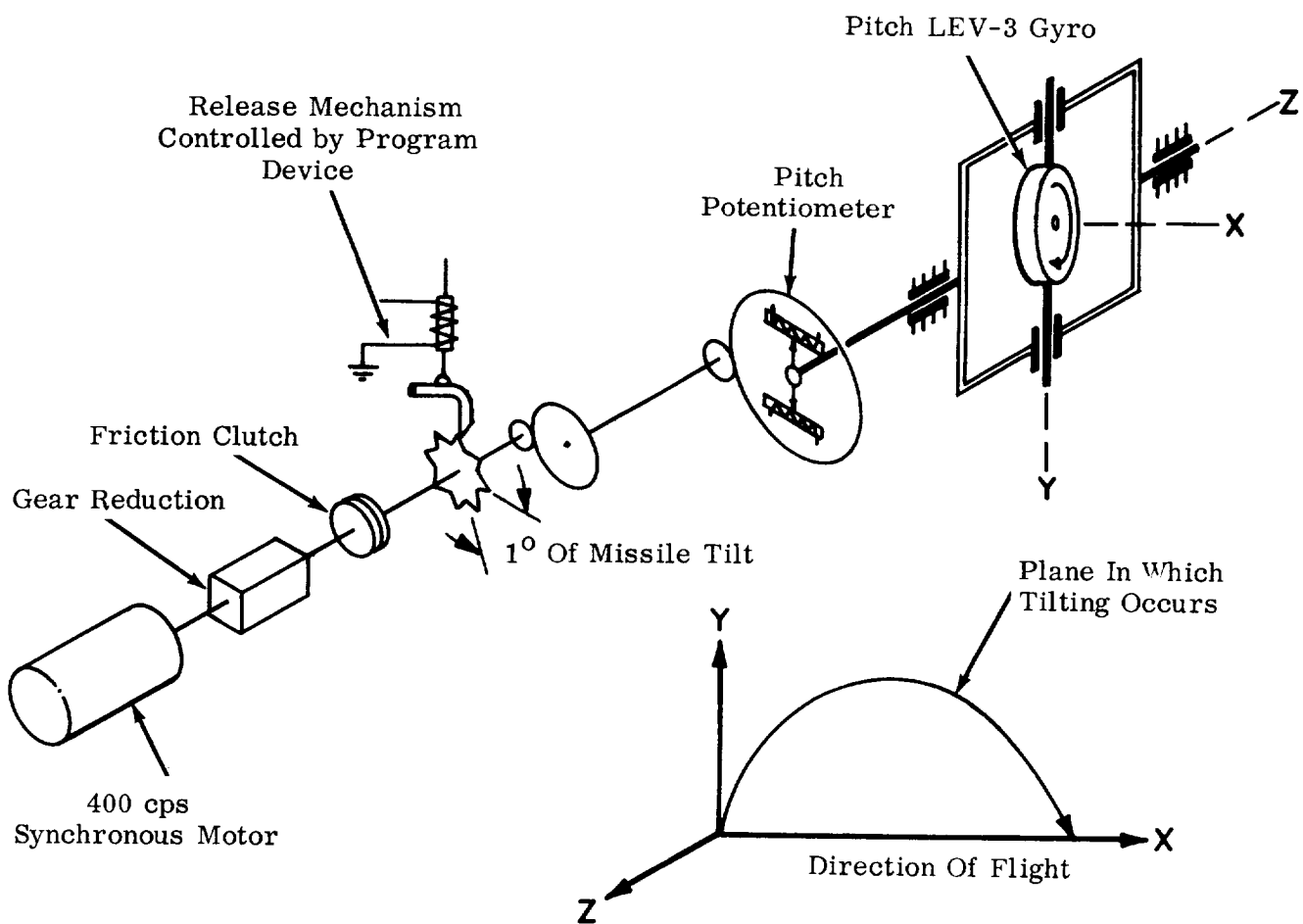

Figure 4-8. Mechanics of Tilting Program

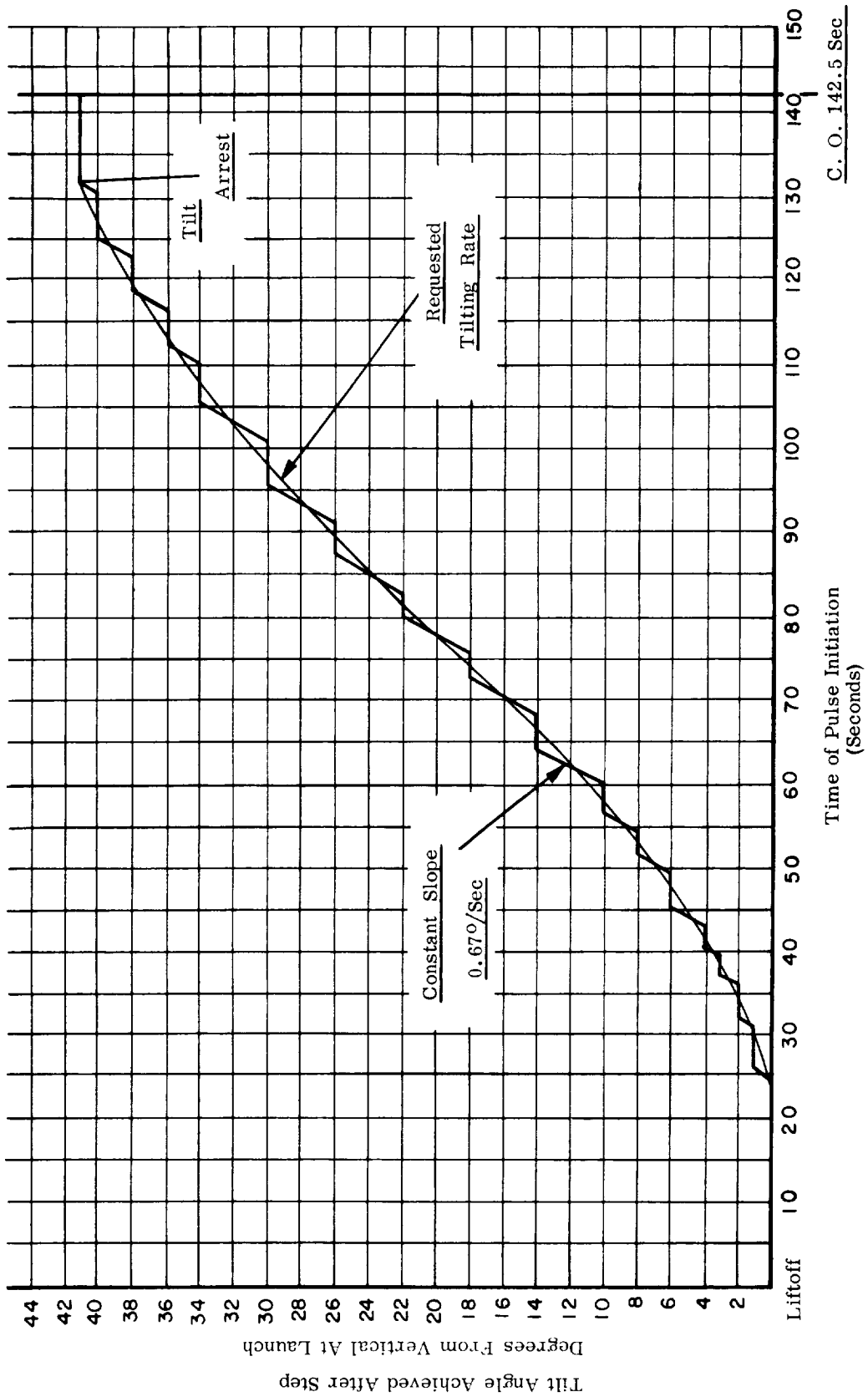

Figure 4-9. Pulse Program for Tilting

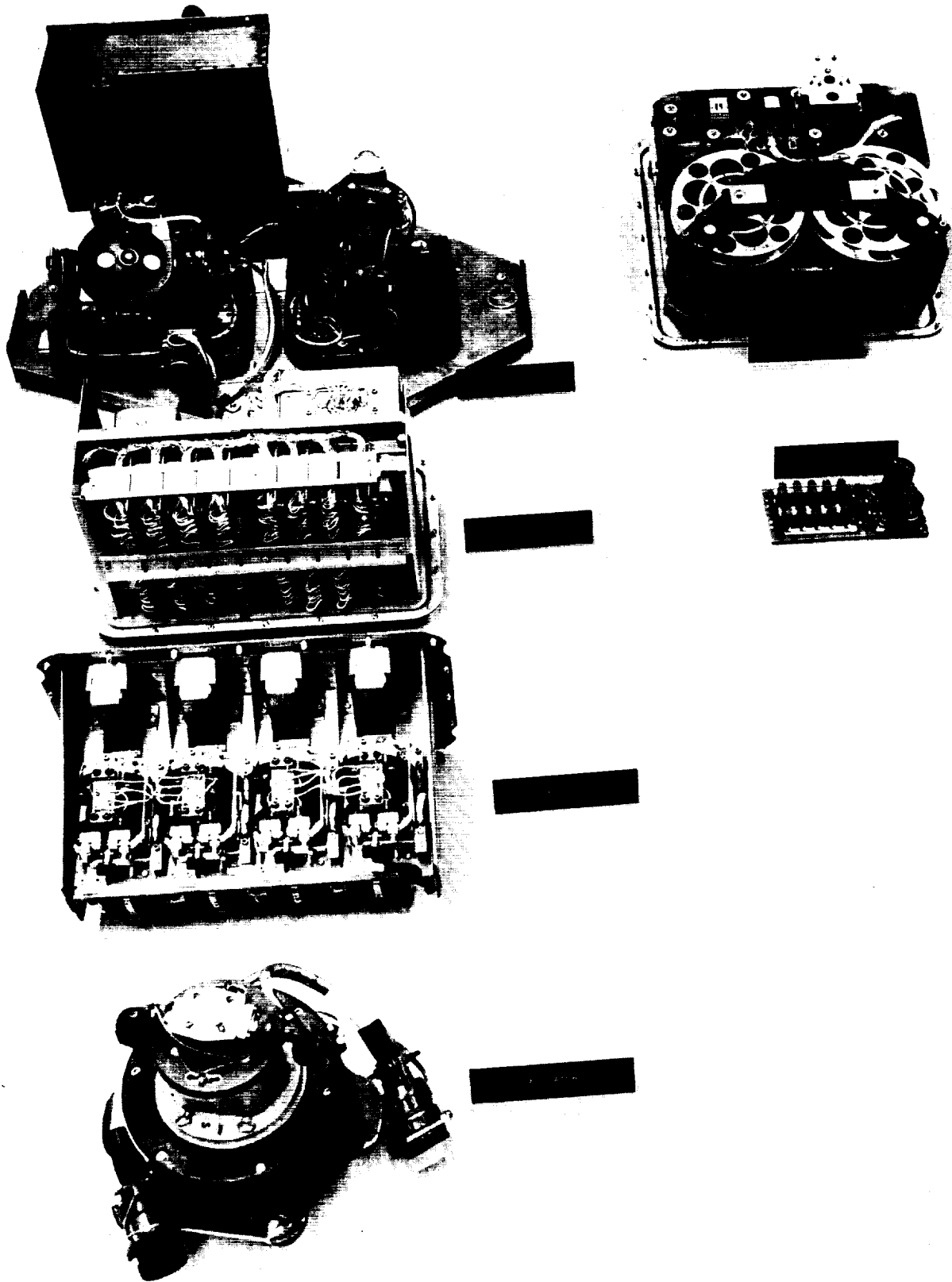

Figure 4-10. MERCURY-REDSTONE LEV-3 Stabilizer System

spin of 22,000 rpm. The gyro wheel weighed 1.5 pounds and had an angular moment equal to 12.106 gm-cm² per second.

Each gyro had a self-erecting element to provide erection prior to liftoff. This element precessed the gyro until the spin axis was perpendicular to the local vertical. Thus, the gyros were not necessarily parallel to the earth's surface or vehicle's longitudinal axis.

The integrator gyro was pivoted at one end of its spin axis and mounted within a junction box containing switching relays. This pivoting allowed the gyro to be precessed as the launch vehicle accelerated. The number of revolutions precessed was proportional to the integral of the acceleration sustained, and, therefore, a measure of the velocity. The output of the gyro indicated both vehicle and gravitational acceleration; the latter was subtracted out by the control computer. The revolution of the gyro was picked up by eight contacts mounted on the gyro case. The signal was transferred from the gyro case by eight flexible coils of wire passing through the hinge line.

4.4.4 CONTROL COMPUTER

The control computer was a magnetic summing amplifier which contained filters, RC networks, preamplifiers, main amplifiers, and a power supply. Its function was to receive the attitude error signals from the LEV-3 system, filter them to eliminate bending influences, differentiate them to obtain angular velocity signals, sum and amplify them, and distribute them to the proper channels of the control relay box.

4.4.5 CONTROL RELAY BOX

The control relay box consisted mainly of four sets (channels) of relays, each set having a signal sensing (polarized) relay and power distribution (heavy duty) relay. The polarized relay received command signals from the control computer, closed its contacts according to the polarity of the signals and thereby energized the proper set of coils in the heavy duty relay. The heavy duty relay contacts when closed, supplied 28 vdc power to the actuator motor, which drove the jet vane-air rudder combination. The actuator velocity signal was fed back to the polarized relay to prevent actuator overshoot. The actuator also had limit switches which interrupted the 28 volt servo power (de-energized the heavy duty relay coils) when the actuator reached preset travel limits.

4.4.6 PROGRAM DEVICE

The program device was an extremely precise, three channel magnetic tape device which provided an accurate onboard clock during the vehicle's flight. It was started at liftoff and during flight provided the tilt program pulses, the vehicle sequencing pulses (through the flight sequencer) and the master telemeter calibration pulses. A principal feature of this unit was the ease and speed with which the program could be changed.

4.4.7 FLIGHT SEQUENCER

The flight sequencer received command signals from the program device and distributed them to the vehicle's electrical system in a single train of time pulses by means of a series relay chain. The following pulses were sequenced as follows:

- 30 seconds Arm abort system engine cutoff.
- 70 seconds Stop fuel tank pressurization.
- 129.5 seconds Arm cutoff to capsule.
- 131 seconds Arm velocity cutoff.
- 135 seconds Arm fuel depletion cutoff.

4.4.8 ROTARY ACTUATORS

The actuators were electro-mechanical devices which converted electrical energy into mechanical energy by a series of gears driven by a dc motor. Each of the four actuator units consisted of a one horsepower dc servomotor, a gear train, a vane position feedback potentiometer, and limit switches on the potentiometer, set at ± 27 degrees. Signals proportional to the vane position and velocity were obtained from each feedback potentiometer.

Actuator position was fed back to the control computer to cancel out the input error signal when the actuator reached its commanded position. Actuator velocity was fed back to the polarized relay in the relay box to slow down the actuator as it neared its commanded position, thus preventing overshoot and control servo loop instability.

The carbon vanes and air rudders were operated by four identical rotary actuators which directly drove the carbon vanes and were coupled to the air rudders by a chain and sprocket drive. The maximum possible deflection for the carbon vanes was ± 27.5 degrees and ± 11 degrees for the air rudders.

4.4.9 VEHICLE DYNAMICS

Two aspects of the vehicle dynamics are considered in this section, normal flight and control malfunctions.

During normal flight, maximum dynamic pressure occurred at 80 seconds after liftoff with cutoff following at 143 seconds (see paragraph 3.2). Throughout this period the center of gravity and center of pressure shifted as shown in Figure 4-11 such that the static margin passed through zero at 89 seconds. At this point the vehicle became aerodynamically unstable. The time at which the instability began would have been earlier had not 487 pounds of ballast and 442 pounds of dampening compound been added to the aft section.

The flight bending moment distribution is shown in Figure 4-12 and the lateral bending modes in Figure 4-13. Both rigid-body and rigid-plus-elastic body calculations are shown. The three sigma plot of bending moment was based on the wind velocities expected at the Cape. These wind velocities used in the calculations are shown in Figure 4-14, and were assumed to build up in the most unfavorable direction from 0 to maximum velocity at a rate of 0.05 meter per second per meter of altitude.

The natural bending frequencies of the MERCURY-REDSTONE were lower than those experienced by the tactical missile. These lower frequencies caused some feedback in the control system (see changes). The lateral bending frequencies are shown in Figure 4-15 and the longitudinal frequencies in Figure 4-16.

Angle of attack was calculated for both ultimate loading and that expected for a three sigma wind. Figure 4-17 shows that the smallest margin (1.5 degrees) occurred at 70 seconds and that at maximum dynamic pressure (Max Q), the margin had increased to over 2 degrees.

Malfunctions in the control system which could have led to a catastrophic damage within the shortest time, generally, would have resulted in control surface hardover. Therefore, jet vane-air rudder hardovers in yaw, pitch, and roll were studied. The effect of hardover on attitude angle is shown in Figure 4-18, on angle of attack in Figure 4-19, and on roll acceleration in Figure 4-20. Roll acceleration can cause a critical "eyes up" condition for the astronaut if the radial acceleration reaches 6 g's. Angle of attack and attitude angle changes were studied because they define the rate at which the vehicle approaches a breakup condition.

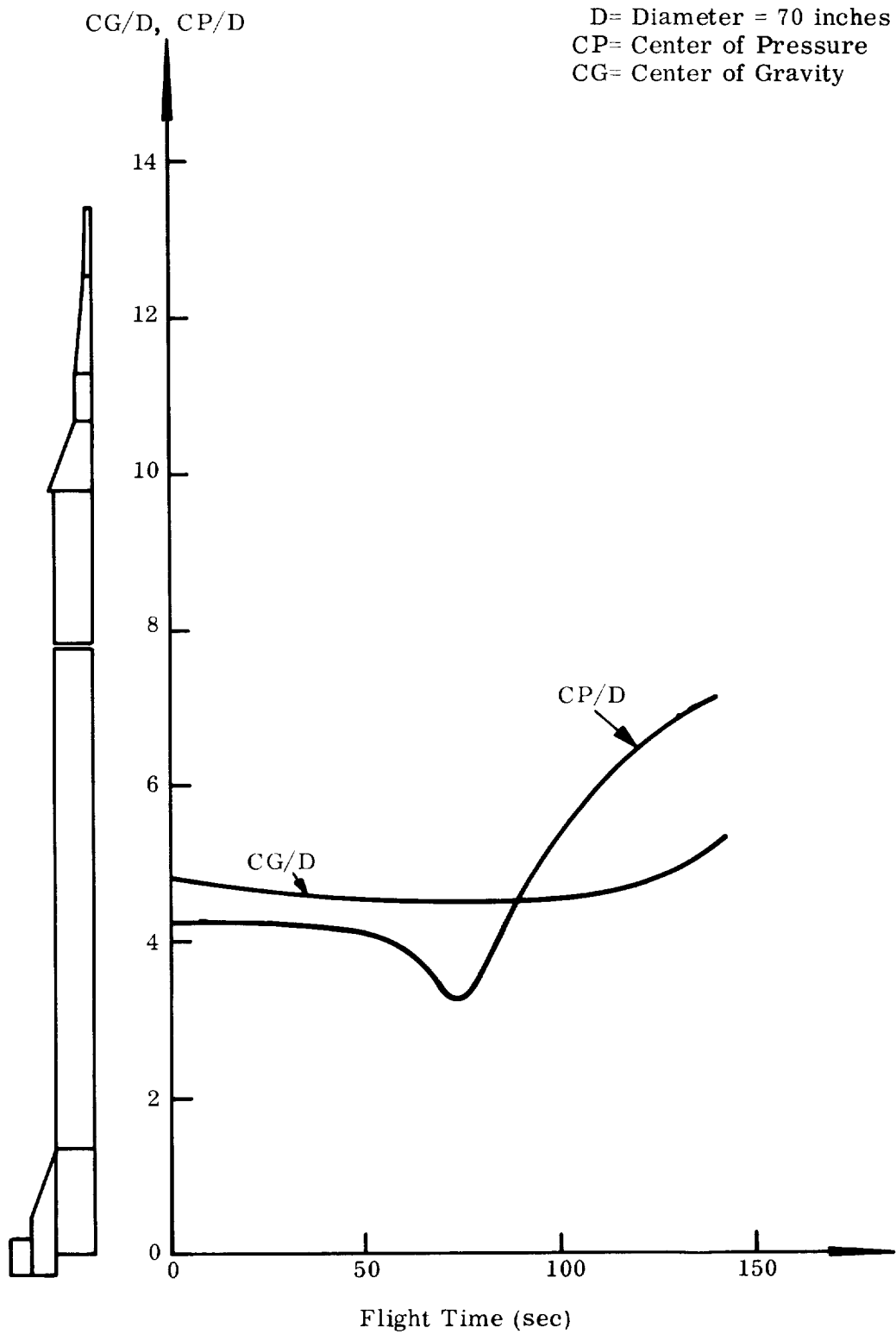

Figure 4-11. MERCURY-REDSTONE Center of Gravity and Center of Pressure Location During Time of Flight

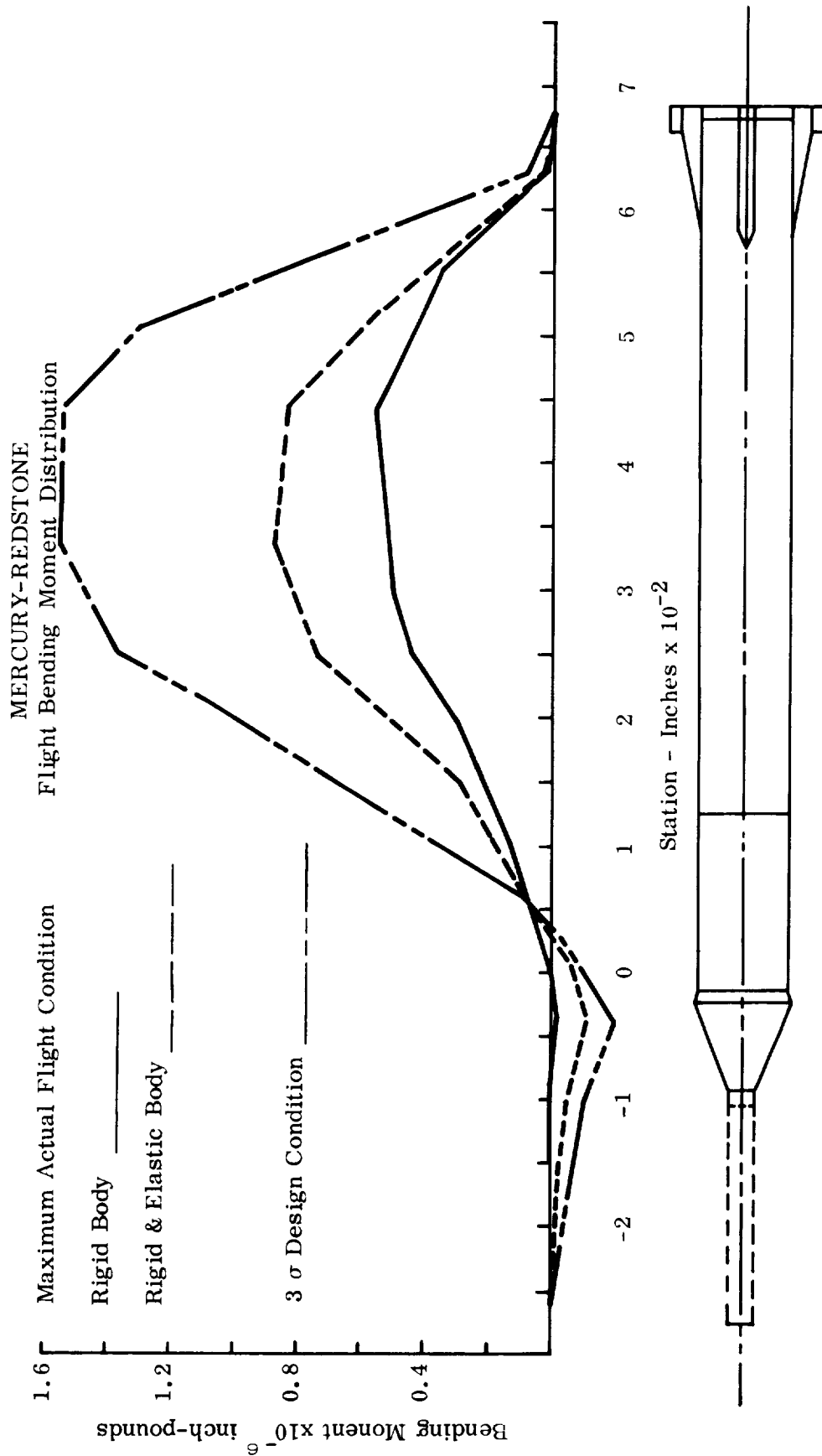

Figure 4-12. MERCURY-REDSTONE Flight Bending Moment Distribution T = 80 Seconds

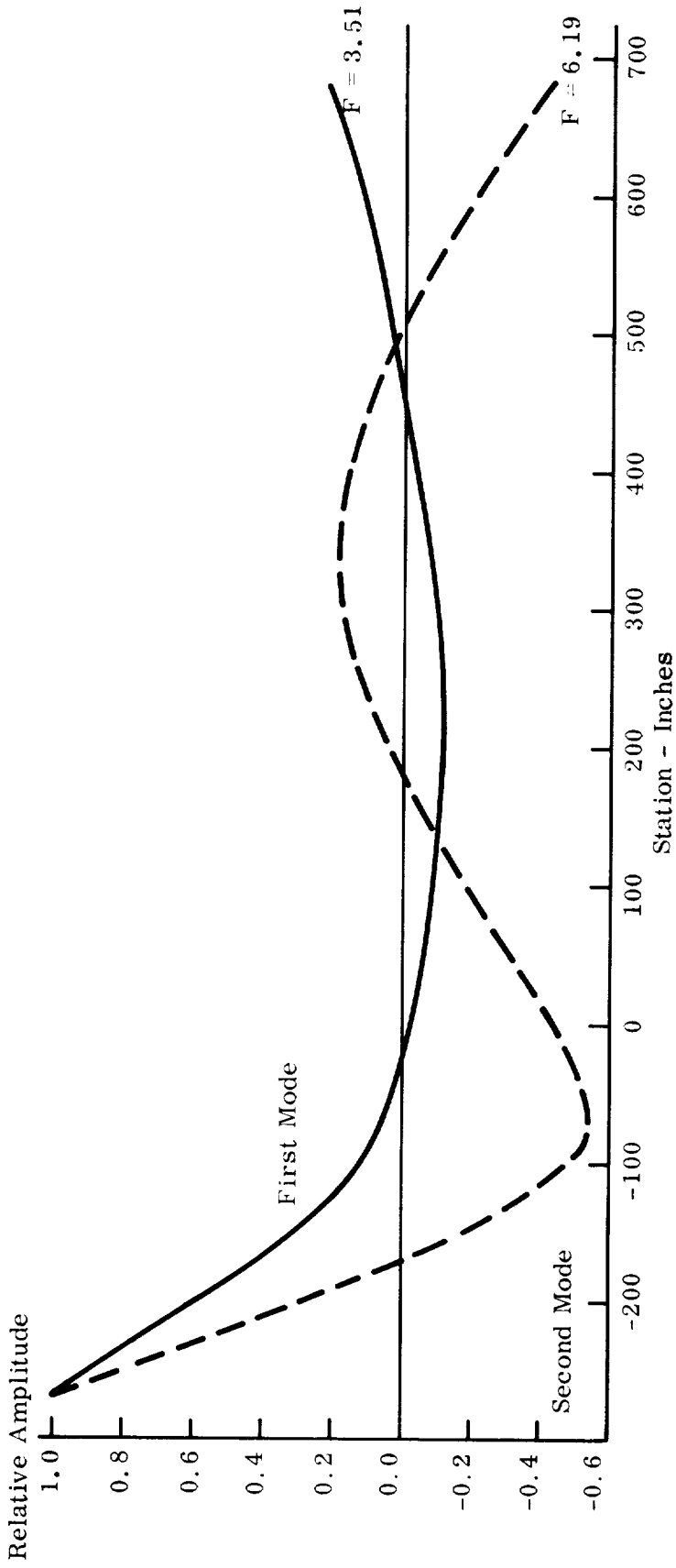

Figure 4-13. MERCURY-REDSTONE - Relative Amplitude versus Missile Station T = 60 Seconds
Free-Free Lateral Bending Modes

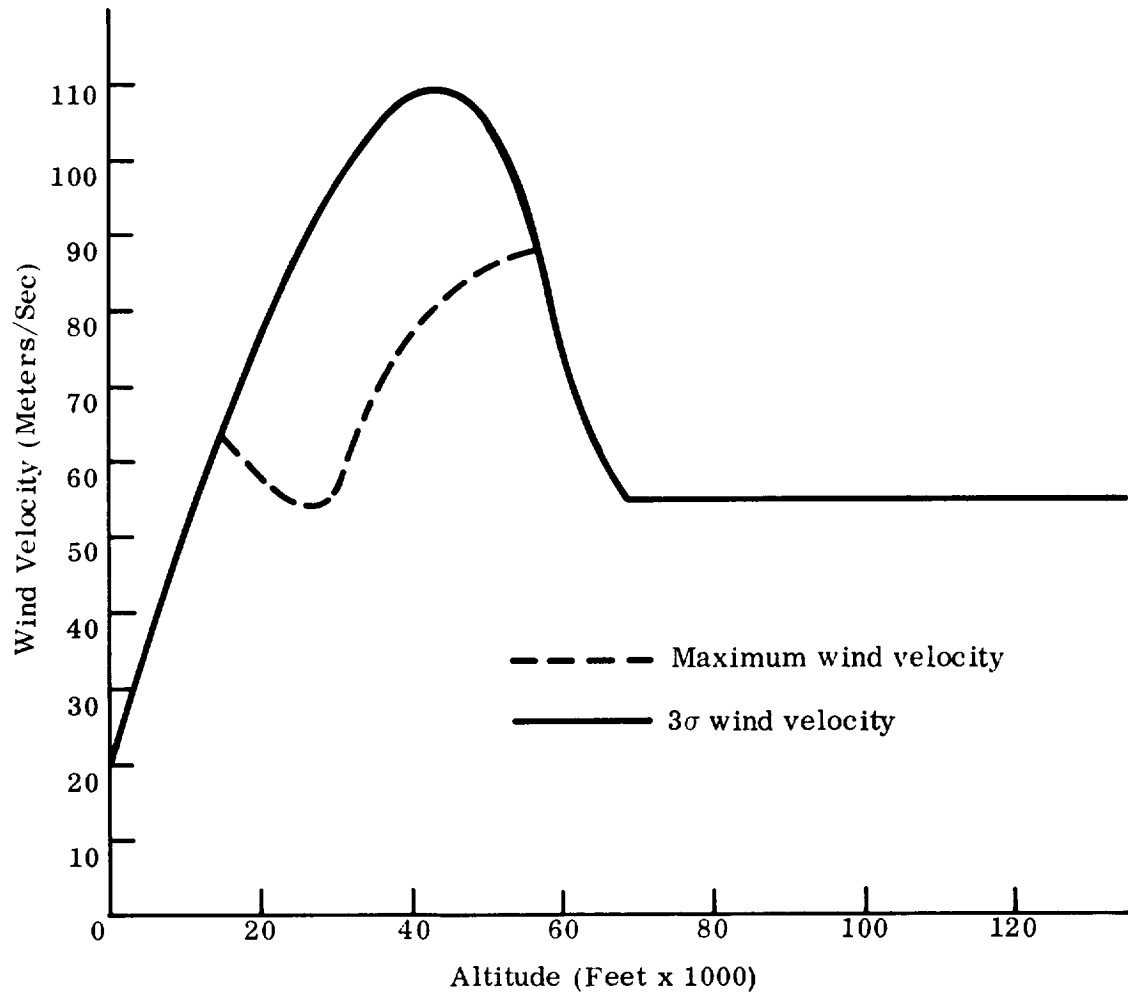

Figure 4-14. Maximum Design Wind Velocity versus Altitude

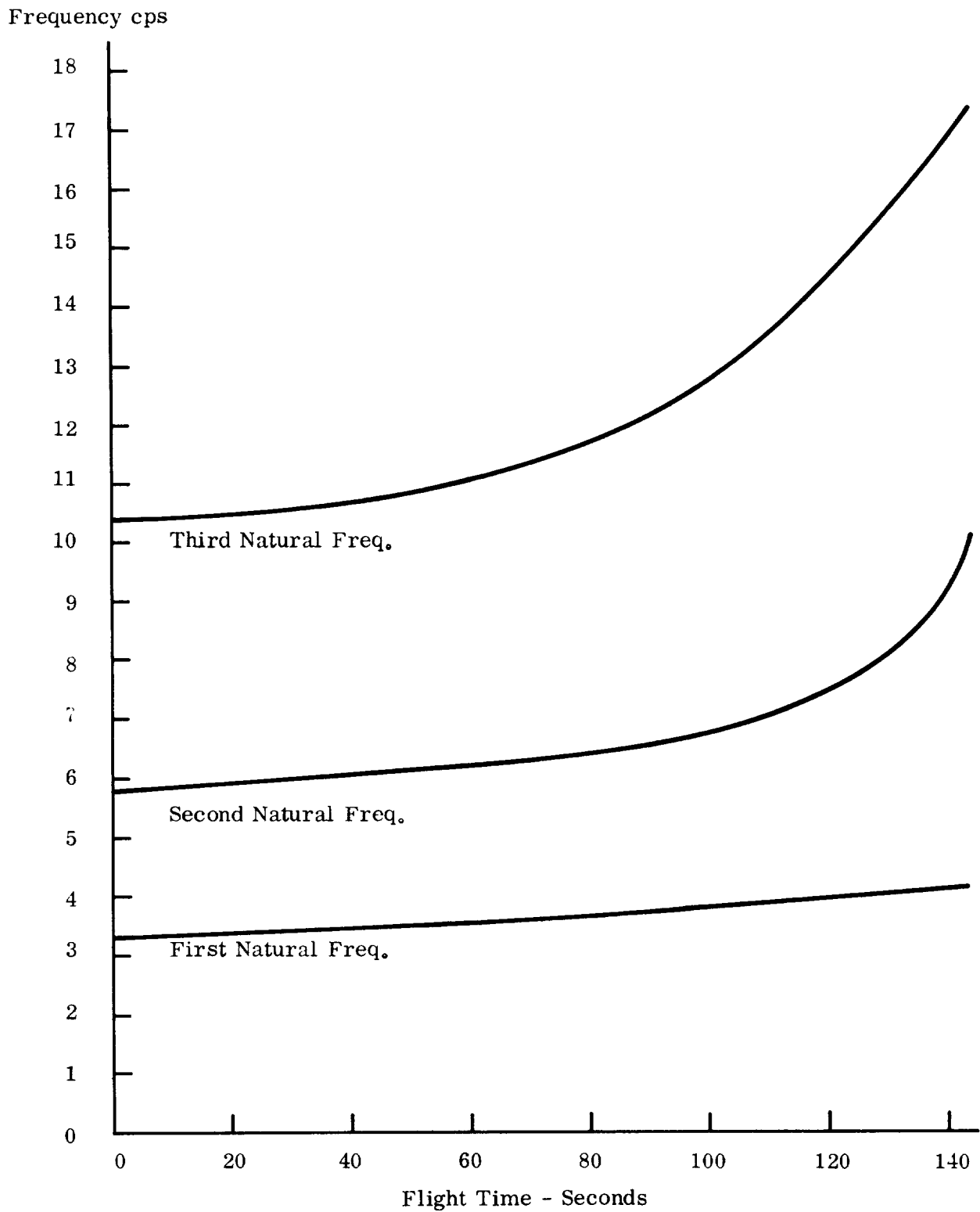

Figure 4-15. MERCURY-REDSTONE Free-Free Lateral Bending Natural Frequency versus Flight Time

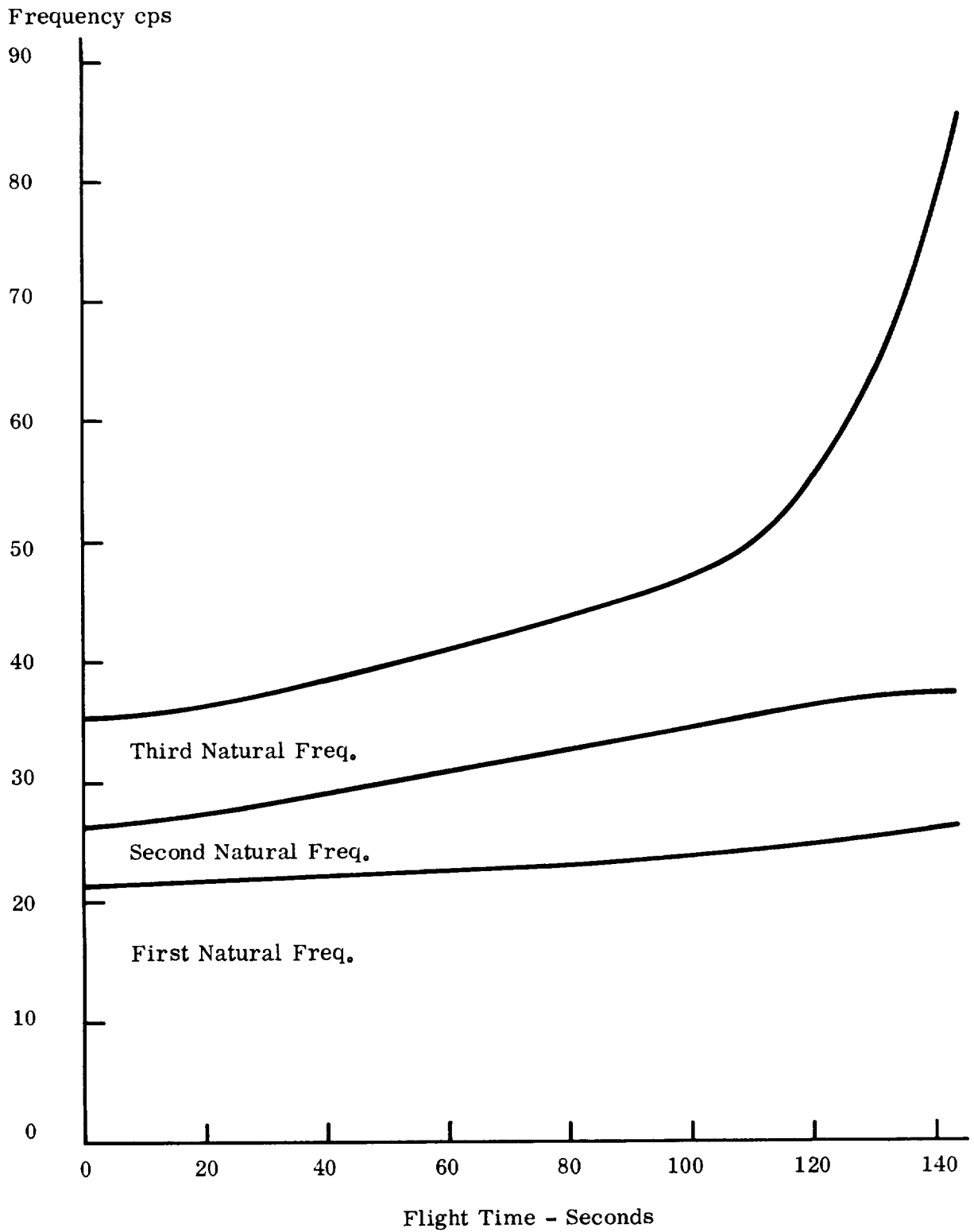

Figure 4-16. MERCURY-REDSTONE Free-Free Longitudinal Natural Frequency versus Flight Time

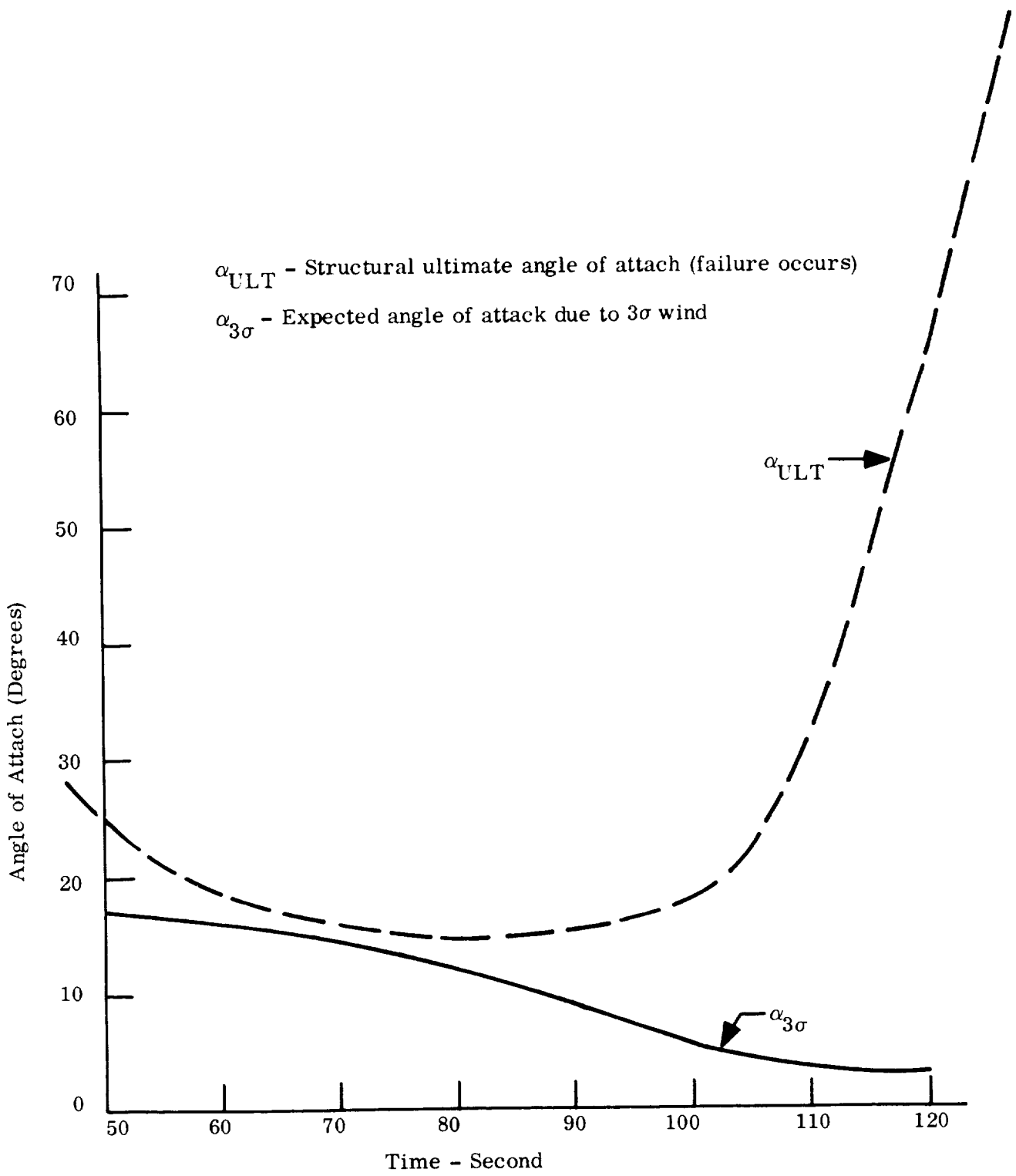

Figure 4-17. MERCURY-REDSTONE Comparison of Angle of Attack versus Time

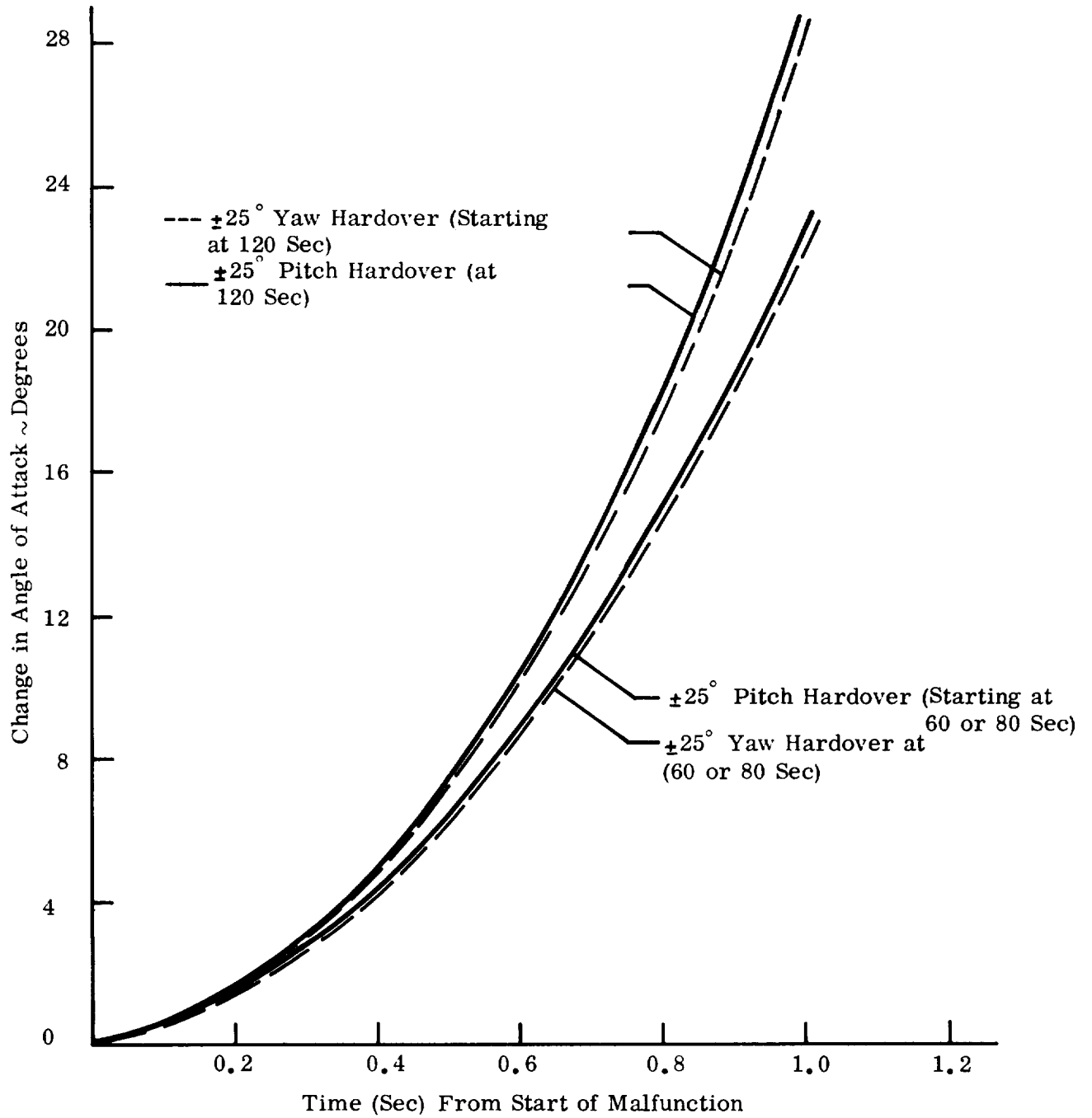

Figure 4-18. Effects of Pitch and Yaw Hardover on Vehicle Angle of Attack (As a Function of Flight Time)

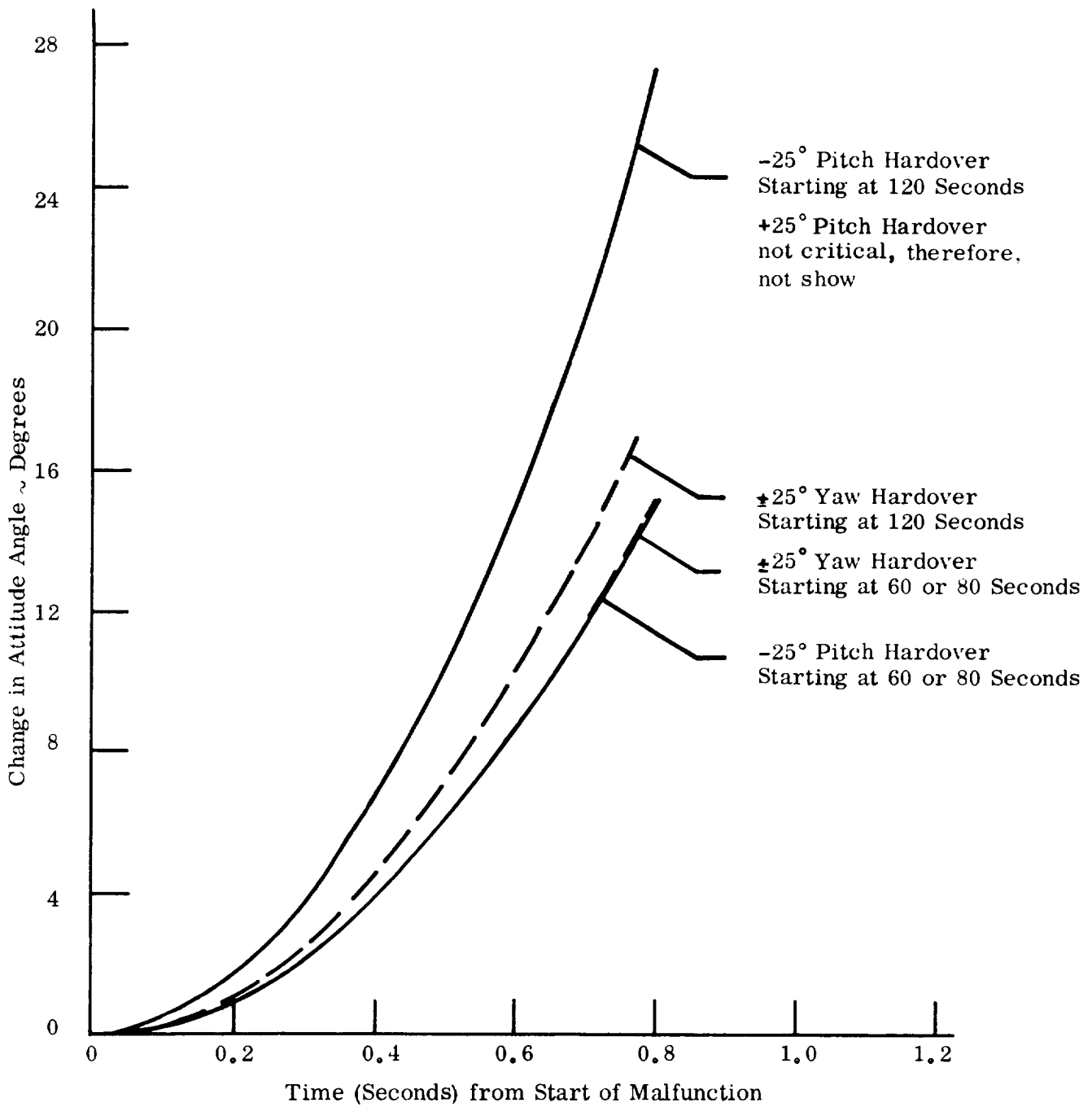

Figure 4-19. MERCURY-REDSTONE Effects of Yaw and Pitch Hardover on Vehicle Attitude Angle (As a Function of Flight Time)

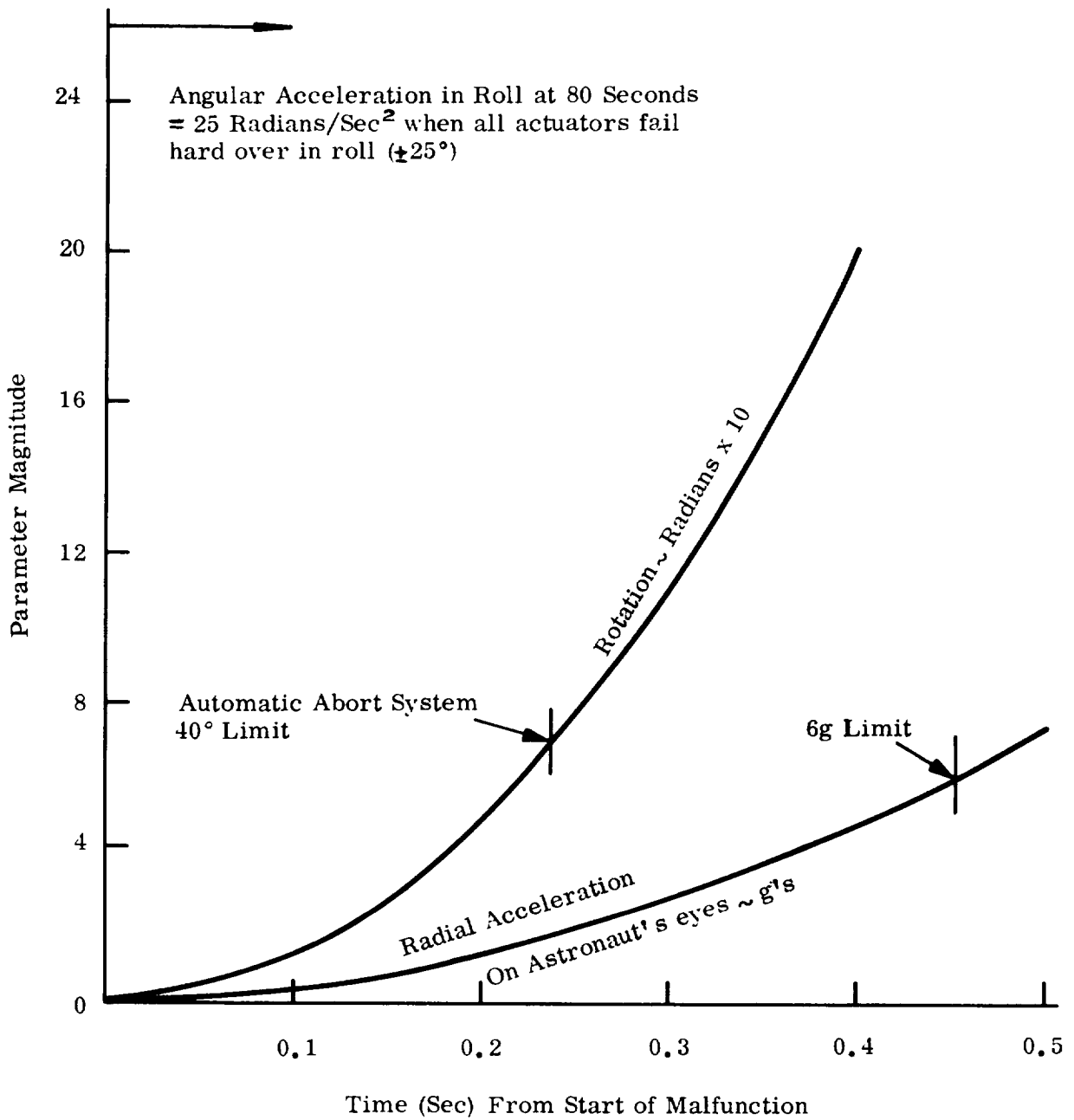

Figure 4-20. MERCURY-REDSTONE Effect of Roll Hardover at 80 Second Flight Time (Worst Case)

4.5 ELECTRICAL POWER NETWORK

The electrical system of the MERCURY-REDSTONE was comprised of a general operational network and a measuring network. The components of the system were contained in the pressurized, temperature-preconditioned instrument compartment in the middle of the aft unit, except for the servo terminal box and the tail distributor which were in the tail unit. A cable conduit running through both propellant tanks connected the power supplies to the terminal box and distributor. Power requirements and supplies are listed below in Table 4-1. Electrical power distribution is shown diagrammatically in Figure 4-21.

Table 4-1
Electrical Power Supplies

Power Type	Source	Equipment Powered
28 vdc	One 1850 amp-minute battery at 10 Minute rate. Zinc-Silver oxide; 72 hour standby life	Control Actuators, One Destruct Command Receiver
28 vdc	One 2650 amp-minute battery at 10 minute rate. Zinc-Silver oxide; 72 hour standby life	General Network Inverter, One Destruct Command Receiver
60 vdc	One 50 amp-minute battery at 10 minute rate. Zinc-Silver oxide; 72 hour standby life	Control Signals
5 vdc	Instrument battery	
115 vac 400 cps	One 1800 volt-ampere inverter and synchronizer	LEV-3 Autopilot, Control Computer, Program Device, AZUSA, DOVAP, Rate Switches, and Measuring System
115 vac 60 cps	Ground Power (nonflight) supplied through 2 connectors in Fin II	Prelaunch: Serving line Strip Heaters, H ₂ O ₂ Heating Blanket

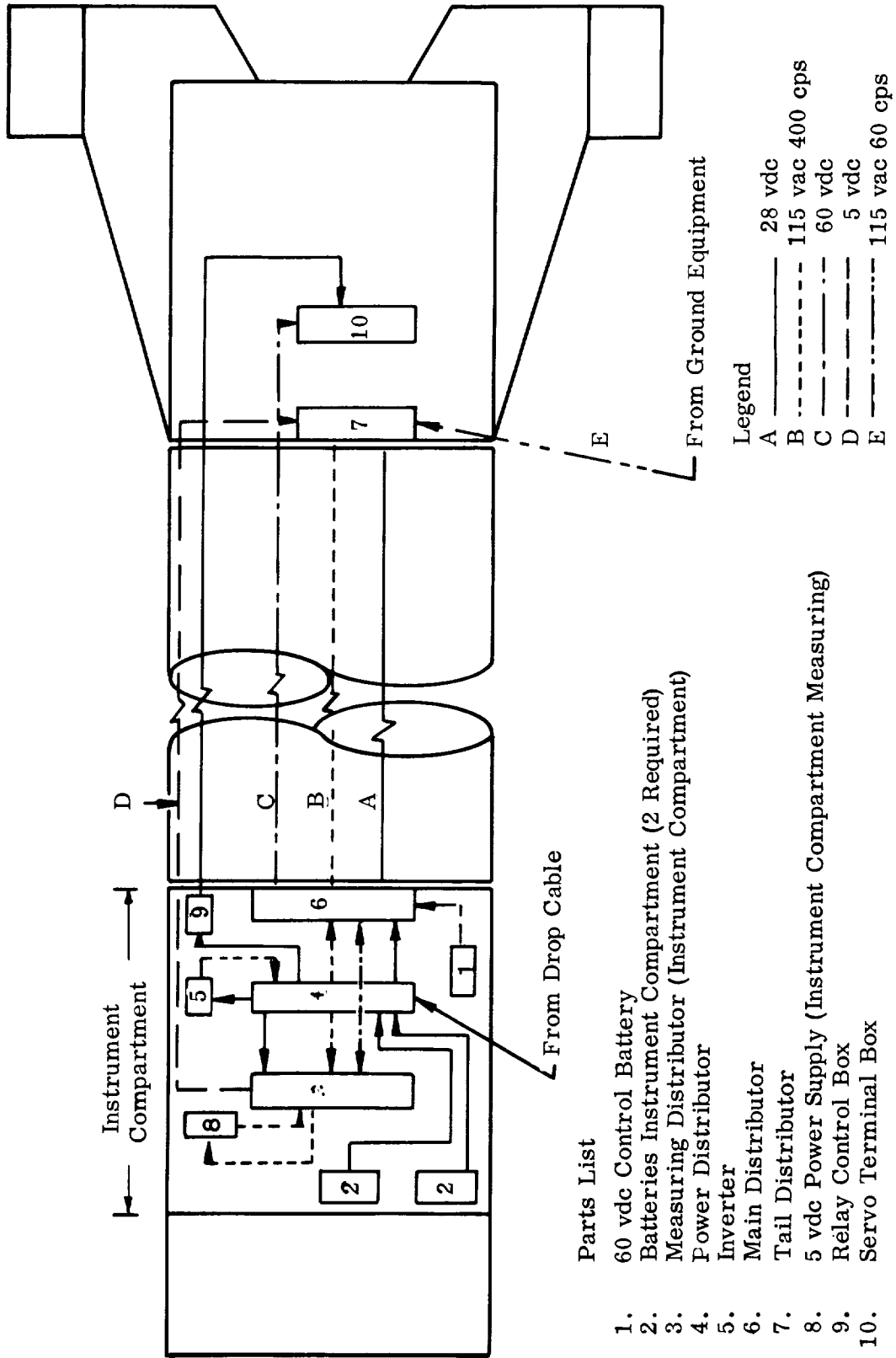

Parts List

1. 60 vdc Control Battery
2. Batteries Instrument Compartment (2 Required)
3. Measuring Distributor (Instrument Compartment)
4. Power Distributor
5. Inverter
6. Main Distributor
7. Tail Distributor
8. 5 vdc Power Supply (Instrument Compartment Measuring)
9. Relay Control Box
10. Servo Terminal Box

Figure 4-21. Electrical Power Distribution

4.6 COMMUNICATIONS, TELEMETRY, AND TELEVISION

4.6.1 GENERAL

The launch vehicle was equipped with measuring equipment capable of receiving and transmitting information before and during flight. This equipment was located principally in the instrument compartment. The major equipment consisted of:

- 2 Command Receivers and Decoders.
- 1 DOVAP Transponder.
- 1 AZUSA Transponder.
- 1 Telemeter Unit.
- 10 Antennas.

4.6.2 COMMAND RECEIVERS AND DECODERS

The command receivers and decoders were the principal components of the command destruct system. The primary purpose of this system was to provide a positive means of engine cutoff and vehicle destruction from the ground. For positive reliability, the system was redundant throughout, sharing only the antennas, the destruct package, and direct connections to these components.

The various command signals were transmitted by frequency modulating (FM), dual-command transmitters (located at the launch site) with selected combinations of audio tones. This FM carrier was received and demodulated by the onboard command receivers. The recovered audio tones were applied to the decoders, which, in turn, energized the proper combination of relays completing the circuitry for execution of the desired command. Reference paragraph 4.7.

4.6.3 DOVAP TRANSPONDER

DOVAP (Doppler Velocity and Position) is a long baseline continuous wave system based on the Doppler principle. It is used to determine the instantaneous velocity and position and to predict ballistic trajectory and point of impact.

The broadcast frequency from the launch site was 36.864 mc. Aboard the vehicle, the DOVAP, Model 0, transponder received a signal from the ground station, which had been shifted in frequency due to the vehicle motion. The signal frequency was doubled and retransmitted to the ground stations. Receiving stations and the transmitting station, being in a known geometrical configuration, allowed for accurate determination of trajectory coordinates.

4.6.4 AZUSA TRANSPONDER

AZUSA is an automatic, high-precision, all-weather electronic trajectory measuring system based upon the interferometer principle. It was used in trajectory and impact prediction. It consisted of a short baseline ground station tied in with an IBM 709 computer and a vehicle-borne transponder. The MERCURY-REDSTONE carried a Model B, Coherent Carrier AZUSA transponder.

4.6.5 TELEMETRY

The MERCURY-REDSTONE telemetering system was a PAM-FM-FM System employing 17 standard subcarrier frequencies modulating a RF carrier of approximately 221.5 megacycles per second. Sixteen channels transmitted information continuously while one channel (channel 15) was commutated at the rate of 10 revolutions per second. The same system had been used successfully in early REDSTONE firings. While the system did not represent the latest development in the state of the art, it is still one of the most reliable systems available. It consisted of a Model XO-2 FM-FM package, a Model 1101 power amplifier, and a power divider.

A total of 41 measurements were made on the launch vehicle in flight. These measurements are listed in Table 4-2. Given are the measurements, their range (if applicable), and a tabulation of the commutated and straight channel assignments for each flight.

4.6.6 ANTENNAS

The following is a list of the number and type of antennas installed on the launch vehicle:

- Command 1 pair, inphase, cavity slot.
- DOVAP 2 pairs, 180-degree phasing, handlebar type.
- AZUSA 1 antenna, tapered wave guide.
- Telemetry 3 antennas, tied together, fed in phase.

Figure 4-22 shows the locations of the antennas.

4.6.7 TELEVISION

On MR-2 only, a television camera was installed on the exterior of the instrument compartment. During the boost phase of flight, the camera transmitted pictures of the

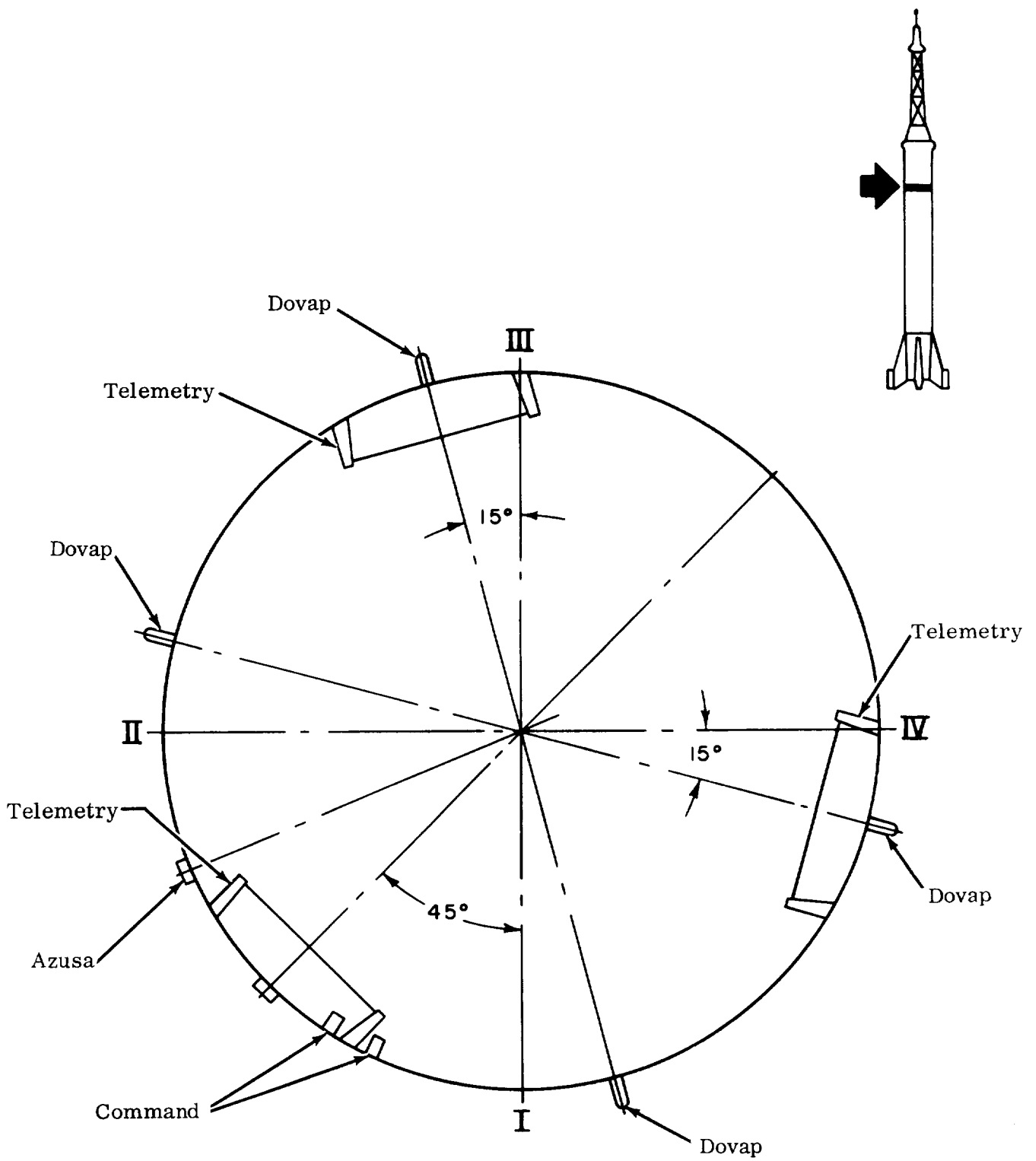

Figure 4-22. Antenna Locations

earth below. The camera was mounted to view upward and slightly inward, thus mirrors were used to reflect the earth's image into the camera lens.

At engine cutoff, the mirrors and their mounting bracket were jettisoned by squib-loaded mechanisms. This permitted the camera to view the separation of the capsule from the booster.

Table 4-2
MERCURY-REDSTONE Booster Flight Telemetry Measurements

Measurement	Type of Flight Telemetry C = Commutated Channel S = Straight Channel (continuous)					
	MR-1	MR-1A	MR-2	MR-BD	MR-3	MR-4
<u>Propulsion</u>						
Pressure in Pressurizing Spheres (0-3500 psi)	C	C	C	C	C	C
Pressure in H ₂ O ₂ Container (0-700 psi)	C	C	C	C	C	C
H ₂ O ₂ Valve Position (0-45 degrees)	C	C	C	C	C	C
LOX Flow Rate (0-25 gallons per second)	S	S	S	S	S	S
Alcohol Flow Rate (0-25 gallons per second)	S	S	S	S	S	S
Pressure of Alcohol at Pump Inlet (0-60 psi)	S	S	C	S	S	C
Combustion Chamber Pressure (0-400 psia)	C	C	C	S	C	S
Error Signal of Thrust Controller (± 5 psia)				C	C	C
Combustion Chamber Pressure After Cutoff	S					
<u>Structural Pressure-Vibration-Temperature</u>						
Instrument Compartment Pressure (0-30 psi)	C	C	C	C	C	C
Instrument Compartment Temperature	C	C	C			
Temperature of AZUSA Transponder Skin	C					
Vibration - Capsule Mounting Ring, Lateral (± 30 g)	S	S	S	S	S	S
Vibration - Capsule Mounting Ring - Low Frequency, (Lateral)				S		
Vibration - Instrument Compartment Rate Switch Bracket (longitudinal)	S	S				
Vibration - LEV-3 Base Plate (longitudinal)			S	S	S	S

Table 4-2 (Cont)

	MR-1	MR-1A	MR-2	MR-BD	MR-3	MR-4
<u>Flight Mechanics</u>						
Angular Velocity-Pitch (± 10 degrees per second)	S	S	S	S	S	S
Angular Velocity - Yaw (± 10 degrees per second)	S	S	S	S	S	S
Angular Velocity - Roll (± 10 degrees per second)	C	C	C	C	C	C
Longitudinal Acceleration (0 to 6 g)	S	S	S	C	S	S
Longitudinal Acceleration (-0.5 to +0.5 g)	S	S	S	C	S	S
Speed Pips (from gyro velocity integrator)	S	S	S	S	S	S
<u>Vehicle Control</u>						
Tilt Program, LEV-3	S	S	S	S	S	S
Input to Flight Sequencer	S	S	S	S	S	S
Gyro Pitch Position (minus Program) (± 15 degrees)	S	S	S	S	S	S
Gyro Yaw Position (± 15 degrees)	S	S	S	S	S	S
Gyro Roll Position (± 15 degrees)	C	C	C	C	C	C
Deflection - Jet Vane No. 1 (± 15 degrees)	C	C	S	S	C	C
Deflection - Jet Vane No. 2 (± 15 degrees)	C	C	C	S	C	C
Deflection - Jet Vane No. 3 (± 15 degrees)	C	C	C	C	C	C
Deflection - Jet Vane No. 4 (± 15 degrees)	C	C	C	C	C	C
<u>Abort System</u>						
Abort Bus Signal	S	S	S	S	S	S
Abort - Attitude Error	S	S	S	C	S	S
Abort - Angular Velocity - Pitch (± 5 degrees per second)	S	S	S	C	S	S
Abort - Angular Velocity - Yaw (± 5 degrees per second)	S	S	S	C	S	S
Abort - Angular Velocity - Roll (± 12 degrees per second)	S	S	S	C	C	C
Abort - Control Voltage	S	S	S	C	S	S
Abort from Capsule	S	S	S	C	S	S
Combustion Pressure Cutoff Switch No. 1	C	C	C	C	C	C
Combustion Pressure Cutoff Switch No. 2	C	C	C	C	S	S
Arm Cutoff to Capsule (on-off)		C	C	C	C	C
Capsule Separation Signal	C	C	C		C	C
Capsule Detached Signal				C		

Table 4-2 (Cont)

	MR-1	MR-1A	MR-2	MR-BD	MR-3	MR-4
<u>Signals</u>						
Liftoff	S	S	S	S	S	S
Cutoff	S	S	S	S	S	S
Emergency Cutoff	C	C	C	C	C	C
Command Control Battery Voltage (45-65 vdc)	C	C	C	C	C	C
Inverter Voltage (105-130 vac)		C	C	C	C	C
Fuel Dispersion - Safe (5 to 2 1/2 vdc)	C	C	C	C	C	C
Fuel Dispersion - Armed (5 to 2 1/2 vdc)					C	C

4.7 FUEL DISPERSION (DESTRUCT) SYSTEM

The fuel dispersion system (destruct system) consisted of two redundantly connected command receivers, a remote arming unit, and prima cords placed in the propellant tanks.

The remote arming unit employed two separate igniter squibs, each capable of igniting the prima cord. This unit was armed prior to liftoff by the launch personnel. The igniter squibs would fire upon receipt of an ignition signal from either command receiver. The command receivers fuel dispersion signal was interlocked to assure liftoff, engine shutdown, and a three-second delay for astronaut escape. The engine shutdown interlock was not included in the range safety officer's destruct command circuit.

Sequencing of the destruct and command signals is explained in paragraph 5.1.5. Figure 4-23 illustrates the destruct system.

4.8 INITIAL DESIGN CHANGES

4.8.1 GENERAL

A basic redesign was necessary to adapt the JUPITER-C to the MERCURY mission. The following changes and additions were made:

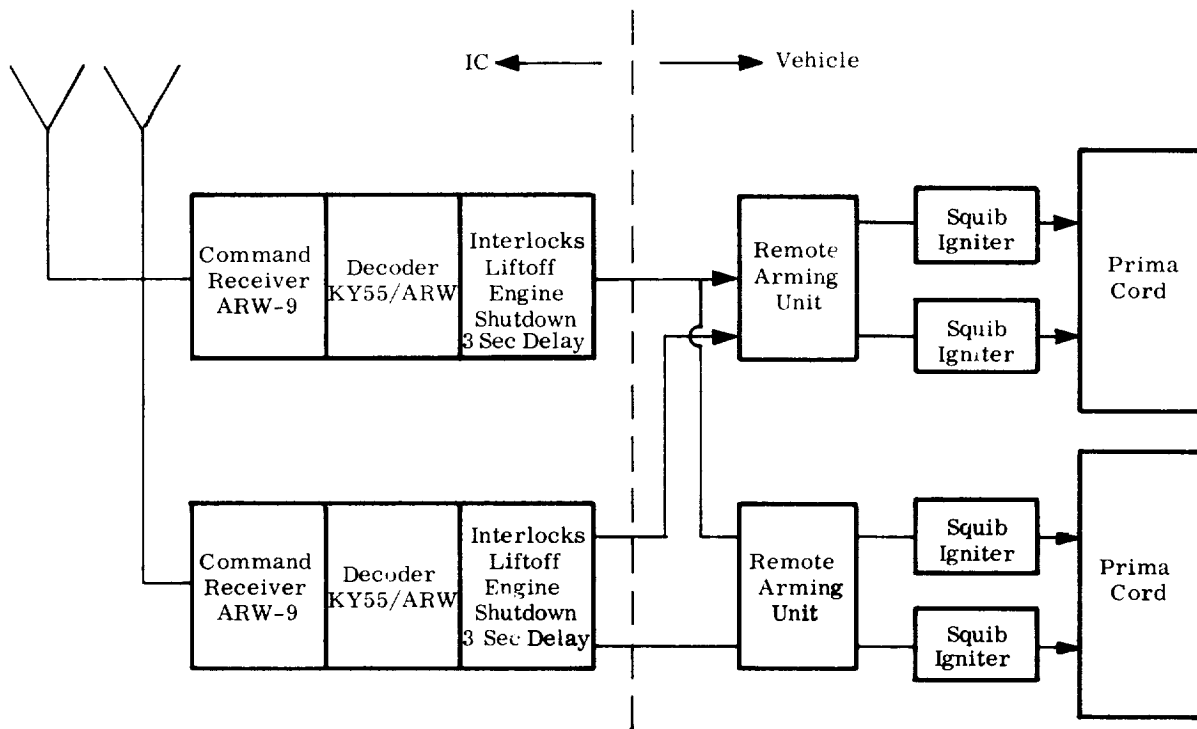

Figure 4-23. Fuel Dispersion (Destruct) System

4.8.2 STRUCTURE

4.8.2.1 Center Section

To meet performance, the elongated JUPITER-C propellant tanks were used. To handle the increased loads due to the capsule and increased propellants, the tank skin thickness was varied.

4.8.2.2 Aft Section

The aft unit and adapter were permanently attached to the center (tank) section. In the military version these had been separated with the payload to provide terminal guidance.

A short capsule adapter including the capsule booster separation clamp ring was supplied by the capsule contractor. This placed responsibility for separation with one contractor.

The aft unit was lengthened 7.08 inches to provide access to the capsule retrorockets.

A fiberglass dish was added in the ballast section initially to protect a booster recovery system and was retained to protect the electronic gear from the heat of the postgrade rockets which fired into the aft section during separation.

A change to increase the reliability of critical electronic components was the pressurization and cooling of the instrument compartment. Layout within this compartment was completely redesigned to accept the new control and abort systems.

Due to its payload and elongated tanks, the MERCURY-REDSTONE became unstable in the supersonic region at approximately 89 seconds after liftoff (refer to Figure 4-10). To partially compensate for this loss of stability, 692 pounds of steel ballast was added forward of the instrument compartment. This was later reduced to 487 pounds during the flight test program as a result of the addition of dampening compound necessary for vibration control.

Because of the extra loads imposed by the increased weight of the MERCURY capsule and propellants, stringers were added to the inner skin structure of the aft unit.

4.8.2.3 Tail Unit

To protect the rotary actuators from the additional heat generated during the longer burning time, stainless steel shields were added to the fins.

A nitrogen gas purge system was added to the tail unit to prevent the accumulation of an explosive mixture in the engine area while on the launch pad.

4.8.3 PROPULSION SYSTEM

Nominal burning time was increased to 143.5 seconds, 20 seconds longer than the REDSTONE.

The greater burning time required the addition of a seventh high pressure nitrogen tank for fuel pressurization, and an auxiliary hydrogen peroxide tank to power the engine turbopump.

To prevent major changes midway in the program, the engine was immediately changed from the A-6 to the A-7 model. The A-6 engine was scheduled for replacement and a shortage of hardware would have occurred during the MERCURY-REDSTONE Program.

This early changeover avoided a foreseeable problem area but required an accelerated test program.

A conservative approach was taken with regard to the choice of propellants. The JUPITER-C had used Hydine for greater performance, but its toxicity was considered undesirable for manned flights. In addition, the A-7 engine had never flown with Hydine. Thus for MERCURY-REDSTONE, alcohol was chosen. This selection led to a problem with the vital jet vanes. Alcohol eroded the vanes faster than Hydine and this coupled with the increased erosion of the vanes. Alcohol eroded the vanes faster than Hydine and this coupled with the increased burning time required a selective program to obtain jet vanes of the highest quality

A fuel line bubbling system was added. By bubbling nitrogen gas through the fuel line during the prelaunch countdown fuel freezing was prevented during long holds.

Chamber pressure sensing line heaters were added to eliminate failure due to water vapor freezing in the lines.

The propellant feed subsystem was modified to include a fixed LOX stand pipe and a ground computer for automatic LOX topping during prelaunch activities.

Within the rocket engine system: the pump volute bleed line was removed, the servo valve was modified, the computer assembly was modified, the main fuel and oxidizer valves were shimmed, and the LOX pump wear ring was changed to stainless steel to eliminate sparking (by maintaining proper blade clearances).

O-ring materials were changed in the hydrogen peroxide subsystem to reduce leakage. (Over-aged seals were also replaced.)

4.8.4 FLIGHT CONTROL SYSTEM

The ST-80 REDSTONE stabilized platform was eliminated and the guidance system replaced by the LEV-3 autopilot.

4.8.5 AUTOMATIC INFLIGHT ABORT SENSING SYSTEM

To assure crew safety, an automatic inflight abort sensing system was added to the booster, and emergency egress operations were incorporated at the launch site. Installation of the automatic inflight abort sensing system sensors required some modification of the other vehicle systems.

4.8.6 ELECTRICAL POWER

Changes to the electrical power and distribution network were required to meet the power and signal path requirements of the new equipment. Supporting instrumentation and ground equipment were also modified or changed to match the new and changed vehicle systems.

4.8.7 INSTRUMENTATION, COMMUNICATIONS, AND TELEVISION

Major changes were made in the instrumentation system to reflect the changes in the vehicle systems and flight experiments.

Several communication systems were added to provide accurate and redundant telemetry and tracking capability.

A television monitoring system was added to the aft unit to display separation to MERCURY Control personnel.

4.8.8 DESTRICT SYSTEM

The fuel dispersion system was modified to include a three-second delay between command destruct and destruct initiation to permit the capsule sufficient time to separate a safe distance from the booster.

4.8.9 GROUND SUPPORT EQUIPMENT

The launch vehicle service structure was modified so that it was remotely controllable, had a semi-clean room at the capsule level, and had a flame deflector and blast shield which protected launch personnel in the event of accidental firing of the escape tower.

Additional air conditioning was added to the blockhouse to offset the heat of the additional electrical test equipment and additional launch personnel.

Additional blockhouse monitoring equipment was installed for the abort system and the H₂O₂ steam generator subsystem.

The capability of abort from the pad necessitated the installation of electrical batteries into the ground support equipment to maintain the launch director's abort capability in the event of power failure on the complex. Electronic equipment was added in the control center to receive telemetry indications of the performance of the onboard abort

system, for monitoring purposes. These data were displayed on two recorders in the control center as part of the electrical ground support equipment (refer to Section 7).

An emergency egress system was added.

Other equipments were added as described in Section 7.

4.9 LATER MODIFICATIONS

4.9.1 GENERAL

During the test programs several problem areas were discovered which required design modifications. These changes occurred as a result of both ground and flight tests. The details concerning the need for the modifications, the methods used to improve the system performance, and the final effects are given in Sections 6 and 8. The listings here are intended for quick reference. Accordingly, the modifications and brief reasons for them are grouped below:

4.9.2 MODIFICATIONS RESULTING FROM GROUND TESTS

- An A-7 engine burning instability was discovered at 500 cps. The injection holes were enlarged to overcome this problem.
- Modification of the static test tower removed a low frequency oscillation which occurred during static firing.
- The following components, susceptible to vibrational failure were modified by additional bracketing, remounting, or beefing up:
 - a. H₂O₂ container bracket.
 - b. Engine piping elbow.
 - c. Abort rate switch mounting bracket.
 - d. Roll rate switch wiring.
 - e. Antenna mounting stud.
 - f. Fuel vent tubing and poppet valve.
 - g. Rate gyro bracket (LEV-3 mounting bracket).

4.9.3 MODIFICATIONS RESULTING FROM FLIGHT TESTING

On MR-3, 340 pounds of X306 (lead impregnated epoxy polysulfide dampening compound) was added to the bulkhead and walls of the ballast section. On MR-4 an additional

102 pounds of compound were added (see Figure 4-24). Longitudinal stiffeners were also added to the internal skin surface as follows:

Flight MR-BD	4 stiffeners
Flight MR-3	14 stiffeners
Flight MR-4	14 stiffeners

Prior to MR-BD the H₂O₂ pressure regulator was set at 570 psig.

After MR-2 the thrust control servo valve was adjusted to a minimum of 25 percent open for smoother starting.

Excessive pivot torque on the LEV-3 longitudinal integrating accelerometer, used for engine cutoff, was prevented after MR-1A by relocation of 5 of 8 electrical leads and use of softer wire on the remaining three. In addition to this accelerometer, a time-based cutoff at 143 seconds was employed on MR-2 and MR-BD.

Velocity cutoff arming and switching of the P_c switches to the depletion mode (fuel depletion arming) were separated after MR-2; also, velocity cutoff arming was advanced to 131 seconds, and fuel depletion arming was set at 135 seconds.

The roll-rate abort sensor was found unnecessary and was deleted after MR-2 to increase mission success.

A network filter was added to the control computer to reduce control loop gain between 6 and 10 cps after MR-2.

After MR-1, a one foot ground strap was added and the Fin II connector mounting modified (see Figure 4-25).

The vibration pickup was moved from the rate switch bracket to LEV-3 baseplate after MR-1A for the remaining flights.

For Flight MR-BD two jet vane deflections, one low frequency vibration transducer, and one engine chamber pressure measurement were telemetered via straight channels. An "Arm Cutoff to Capsule" switch was added to the blockhouse propulsion panel after MR-1.

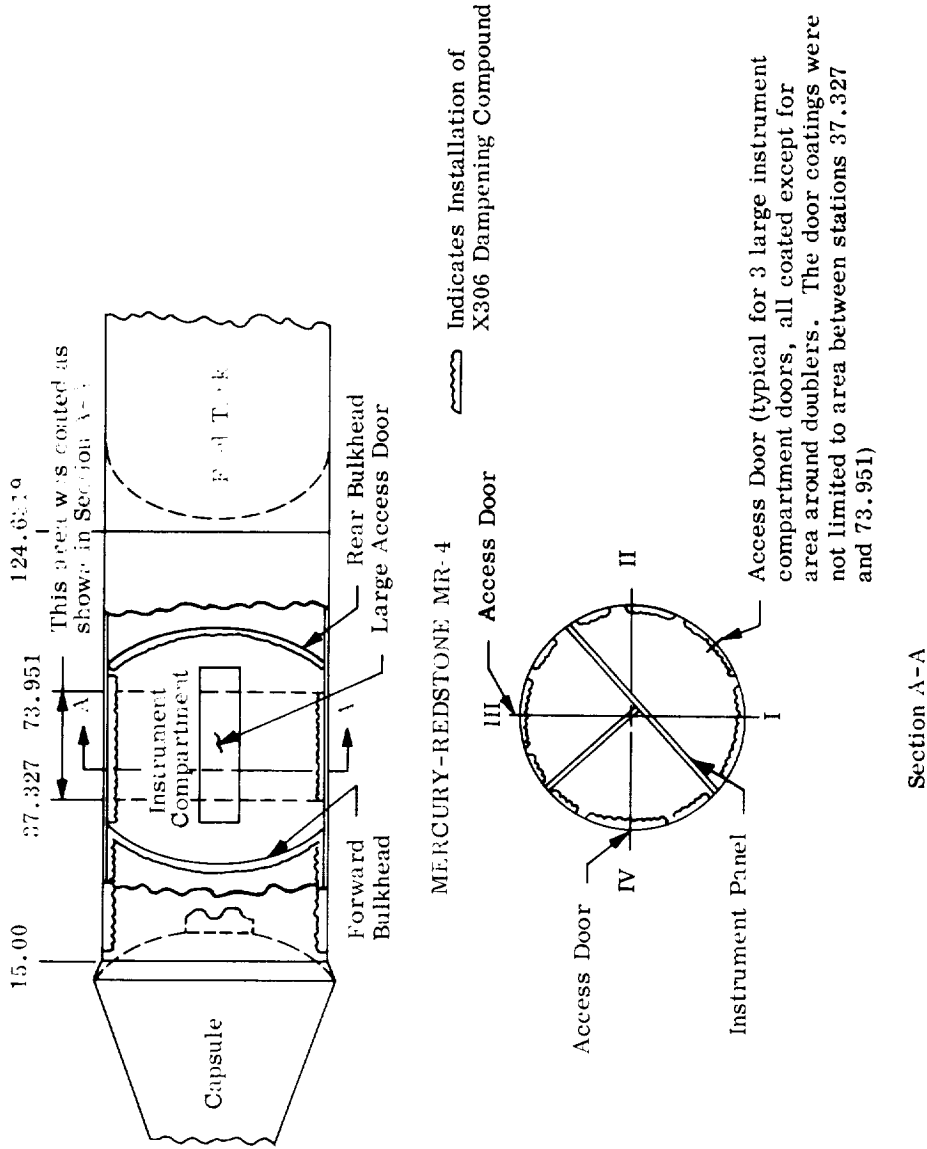

Notes:

1. The dampening compound shown to the rear of the forward bulkhead is unique to the MR-4 booster.
2. All compound shown forward of the forward bulkhead (including that on the bulkhead) was also on MR-3.
3. Arrangement of stiffeners (14 total) was same as MR-3.

Figure 4-24. Installation of Dampening Compound in Instrument Compartment and Adapter Section

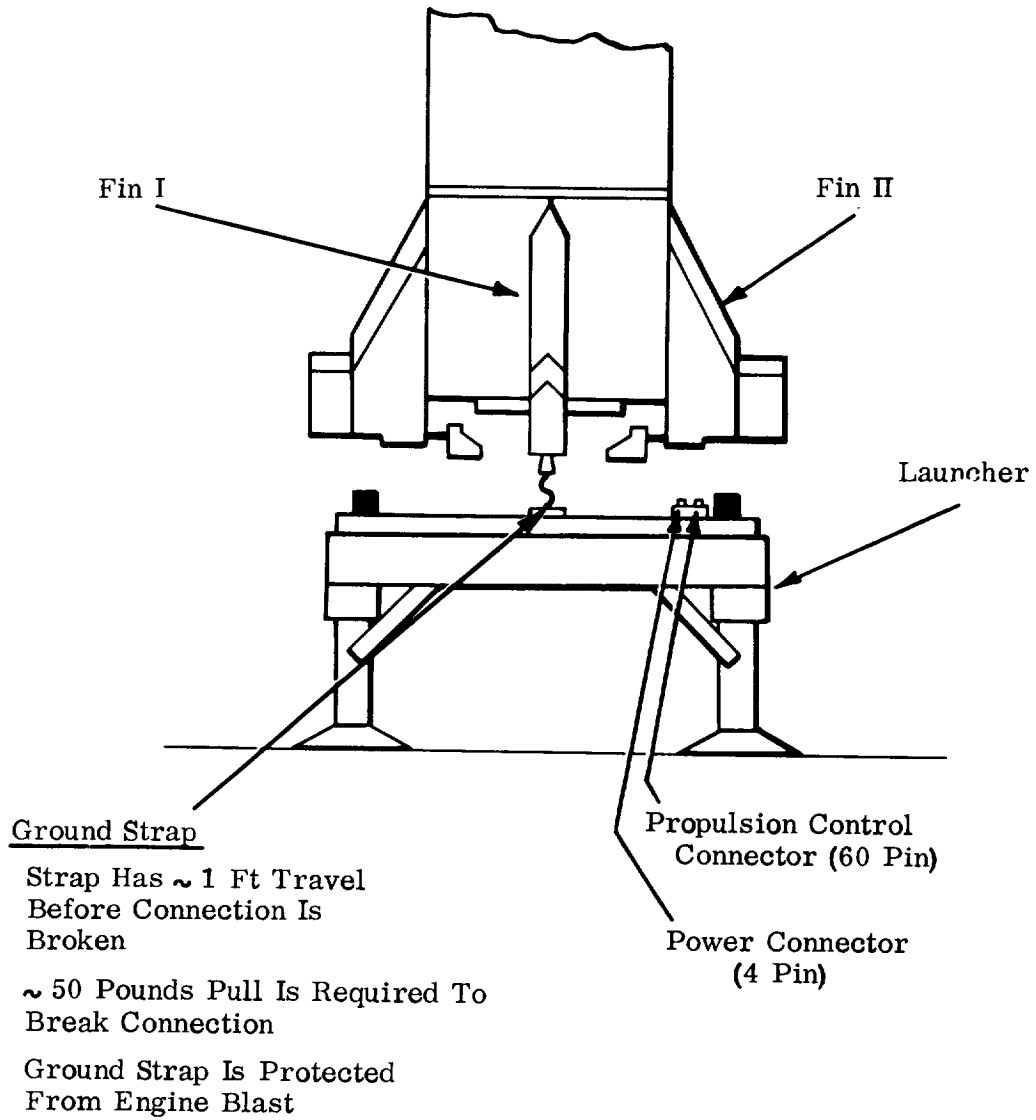

Figure 4-25. Ground Strap Function Just After Liftoff

SECTION 5
MAN-RATING

5.1 INTRODUCTION

The man-rating program for the MERCURY-REDSTONE was planned to achieve the highest possible crew safety by providing abort capability from the time of astronaut boarding through capsule separation. This safety was further increased by quality and reliability assurance programs designed to improve the mission reliability of the basic vehicle. The success of the man-rating programs was not only demonstrated by perfect vehicle operation during the two suborbital flights, but also by the proper monitoring of the abort sensing system during each of these flights.

The MERCURY Program was initiated at a time when the REDSTONE booster had been well developed and had an established reliability. This reliability, which was high for a tactical missile (see Section 2), was still considered insufficient for manned flight. To redesign for the required assurance could have meant a totally new program and a lower reliability; therefore, the man-rating program was based on increasing the astronaut's safety by adding an abort system and making only those vehicle changes necessitated by mission requirements.

In January 1959, the Army Ballistic Missile Agency (ABMA) received the go ahead for missile adaptation. The following March, the Space Task Group (STG) requested ABMA to design an abort system. During May and June, coordination meetings were held between STG, ABMA, and the McDonnell Aircraft Company. In June 1959, ABMA submitted an abort system proposal. The abort system was to be installed on all flights with only the first flight to be "open loop," thus obtaining the greatest amount of full system testing possible. During 1959 and 1960, additional quality control and test procedures were phased in as permitted by the launch schedule.

5.2 AUTOMATIC INFLIGHT ABORT SENSING SYSTEM

5.2.1 GENERAL

The automatic inflight abort sensing system was developed to detect vehicle malfunctions which could lead to a compromise of the astronaut's safety. If such a malfunction was sensed, the abort system would shutdown the booster engine and send an abort

signal to the capsule. This signal activated the escape system through the MAYDAY relays. The abort sensing systems thus, had to be compatible with the vehicle, the capsule interface, and the modes of flight operation. A block diagram of the system is shown in Figure 5-1.

5.2.2 SYSTEM CRITERIA

Crew safety required immediate and decisive action in the event an emergency condition developed. The abort action had to prevent the emergency condition from becoming a catastrophe, i. e. , a condition which gravely endangered the life of the astronaut. An automatic abort sensing and implementation system was selected since some emergency conditions could develop too rapidly to permit manual activation of abort. In addition, an automatic system would relieve an astronaut, whose performance under flight loads was not well established, from the requirement to monitor and sense all emergency situations.

5.2.3 SYSTEM GUIDELINES

The guidelines for the development of this system were as follows:

- The abort sensing system shall be tailored to the critical performance parameters of the launch vehicle.
- The abort sensing system components shall be located on the launch vehicle and one signal sent to the capsule.
- The abort signal shall be given as soon as possible after an emergency condition exists.
- The system shall be activated at liftoff and completely deactivated at engine cutoff.

The guidelines for system design were as follows:

- Existing launch vehicle hardware, for sensing signals, shall be utilized wherever possible.
- Parameters shall be sensed which most easily and reliably monitor the greatest possible number of malfunctions.
- Electrical power for the sensors shall be taken from the launch vehicle's normal ac and dc supply systems. Loss of power shall be an abort condition.
- GSE monitoring shall be required.
- Sensor and system performance shall be telemetered in flight.
- Switching of sensors or sensor limits during flight shall be minimized or eliminated.

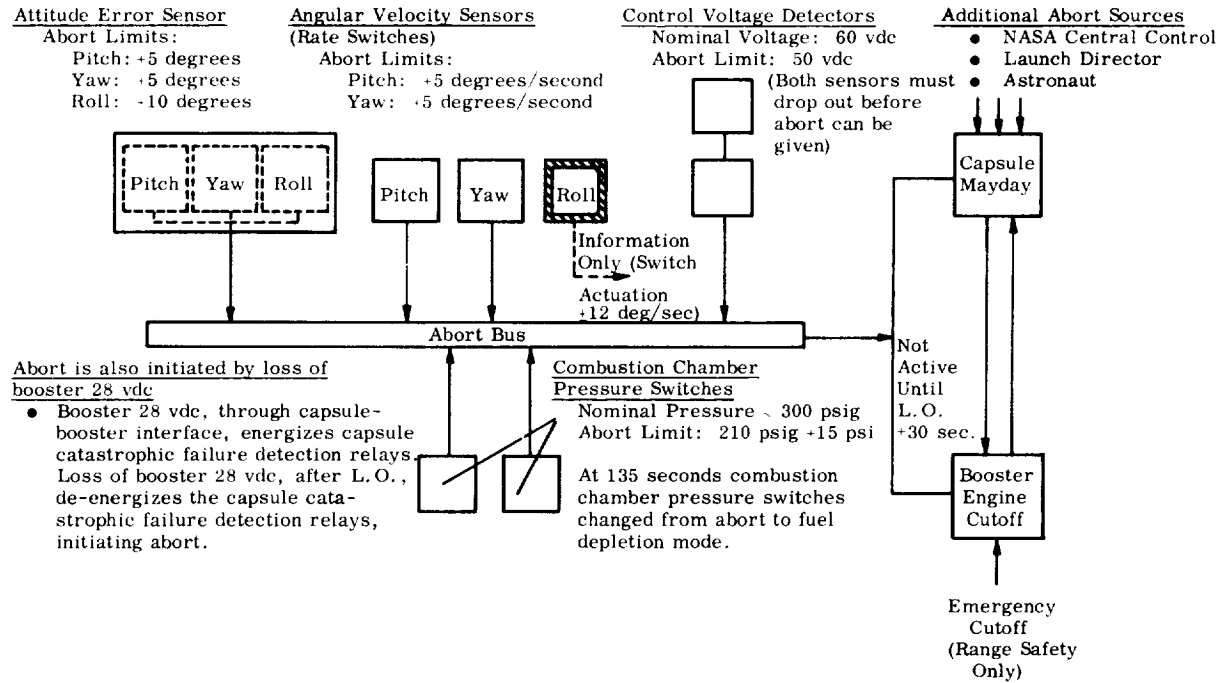

Abort System Telemetered Information

- Abort Bus Signal
- Attitude Error Abort Signal
- Rate Switch Abort Signals (Pitch and Yaw)
- Control Voltage Detector Abort Signal
- Combustion Chamber Pressure Abort Signal No. 1
- Combustion Chamber Pressure Abort Signal No. 2
- Abort Signal from Capsule

Notes:

- The booster automatic abort system becomes active at lift-off.
- At normal booster engine cutoff the capsule will no longer accept a booster abort signal.
- Prior to lift-off the abort bus and booster abort sensors are at all times supervised in the ground support equipment.

Figure 5-1. Block Diagram of MERCURY-REDSTONE Automatic Inflight Abort Sensing System

The guidelines for hardware design were as follows:

- Flight-proven equipment shall be used to the greatest extent possible.
- All equipment shall be subjected to a thorough qualification test program.
- All components of the abort sensing system shall be subjected to a thorough reliability test program.

5.2.4 MALFUNCTION AND PERFORMANCE STUDIES

Prior to selecting the abort parameters, a failure mode analysis was made of 60 REDSTONE tactical missile flights to determine the best choice of malfunction sensors (Table 5-1). The study included a large number of components which had failed or could conceivably fail and found that sensing each component and mode of failure was both impracticable and degrading to operational reliability. However, the study did indicate that many malfunctions led to identical results, thus permitting the use of only a few basic types of sensors. The parameter sensors and limits selected are given in Table 5-2.

To determine the abort limits in attitude and angular rates, probability studies were made based on REDSTONE performance. The results, tabulated in Table 5-3, led to the final selection of the abort limits. The chamber pressure limits for abort were established by a study of the thrust buildup and normal fluctuations, (Figure 5-2). The electrical voltage limit was set just above the minimum required to operate the missile electrical systems.

5.2.5 ABORT SENSING RELIABILITY

5.2.5.1 General

With the addition of an abort sensing system to the launch vehicle, mission reliability is decreased due to the probability of a false abort signal curtailing an otherwise successful mission. Redundancy was used in the sensing system in order to overcome this potential problem (which could also subject the astronaut to unnecessary hazards) and also to reduce the probability of failing to detect an actual emergency condition. The following paragraphs describe specifically how redundancy of parameters and sensors was employed to improve the probability of detecting an actual abort condition and to reject a false abort signal.

Table 5-1

Flight Failure Analysis of REDSTONE Propulsion System

Mode of Failure	Probable Cause	Corrective Action
1. Rough combustion	Dry and slow start.	Full flow LOX and water lead start was employed.
2. Gas generator system performance drop.	a. H ₂ O ₂ tank pressure regulator failure. b. H ₂ O ₂ depletion. c. Vortex in H ₂ O ₂ tank.	a. Improved pressure regulator (8073214) was employed. b. Adequate H ₂ O ₂ was provided. c. Anti-vortex baffles were employed in the H ₂ O ₂ tanks.
3. LOX container pressure decay.	LOX vent valve failure.	Valve bearings were redesigned to lower friction.
4. LOX depletion (cutoff earlier than predicted)	High LOX flow, and preliminary data used in flight prediction analysis.	Reliable test data became available and were used in MR flight prediction analysis.
5. Rapid decline in combustion chamber pressure and turbine RPM.	Increased pressure drop across the gas generator system during flight.	Gas generators on all engines were inspected for proper loading. Static firing of the boosters included operation from nominal to high and then to low thrust levels in 10 steps.
6. Thrust control system improper operation.	a. Water froze in pressure transducer sensing line. b. Improper servo valve calibration.	a. Strip heaters were installed on pressure transducer sensing lines to maintain temperature above freezing. b. Interchange of servo valves was not allowed. Replacement limited to use of recalibrated spare only.
7. Thrust control system inoperative	Servo valve electrical cable not connected (human error).	Electrical cable to servo valve disconnect was not permitted during checkout on MR vehicles.
8. Low missile acceleration on ascent.	Improper calibration of propellant flow (human error).	Reliable test data became available and were used in MR calibrations.

Table 5-1
Flight Failure Analysis of REDSTONE Propulsion System (Cont.)

Mode of Failure	Probable Cause	Corrective Action
9. Cutoff velocity, flight time, and range greater than predicted.	Same as 8.	Same as 8.
10. Fuel depletion (cutoff earlier than predicted).	Insufficient amount of fuel on board at liftoff.	Recording flowmeter was employed during tanking.
<p>A review of the REDSTONE propulsion system inflight malfunction and performance deviations was conducted to ascertain that necessary actions were taken to correct the possible deficiencies of the MERCURY-REDSTONE booster.</p> <p>Note: Failure 1 and 3, which occurred during flight tests of earlier REDSTONE missiles, resulted in unsuccessful accomplishment of the booster and missile mission. The other 8 failures were less serious and permitted the boosters to complete their missions.</p>		

Table 5-2
MERCURY-REDSTONE Abort Parameters

Parameter	Sensor	Limit and Tolerance
Vehicle Attitude Pitch Yaw Roll	Attitude Error Sensor Pitch Yaw Roll	5 degrees, +1 degree -0 degree 5 degrees, +1 degree -0 degree 10 degrees, +2 degree -0 degree
Vehicle Angular Velocity	Pitch Rate Switch Yaw Rate Switch	+5, +0.3, -0 degree per second +5, +0.3, -0 degree per second
Engine Combustion Chamber Pressure	Pressure Switch	210 \pm 15 psig
60 vdc Control Power Supply	Control Voltage Detector	50 \pm 2 vdc
28 vdc General Network Power	Capsule-Launch Vehicle Interface Connector	Loss of voltage if connector opened

Table 5-3

REDSTONE Attitude Angles and Rates During
A Normal Ballistic Trajectory

Predicted Maximums			
Item	Probability less than 0.155 at 95 percent confidence*	Probability less than 0.058 at 95 percent confidence*	Probability less than 0.028 at 95 percent confidence*
Attitude Angles (degrees)			
Pitch	2.3	2.9	3.3
Yaw	3.9	5.0	5.8
Roll	3.1	4.0	4.7
Attitude Rates (degrees per second)			
Pitch	3.2	4.0	4.7
Yaw	2.0	2.5	2.9
Roll	7.0	9.25	11.2
* Probability calculated from flight test data of 50 previous REDSTONE and JUPITER-C launches.			

5.2.5.2 Detection of an Actual Vehicle Malfunction

If a particular sensor failed, redundancy in the system would enable the malfunction to be detected either by sensors of related vehicle performance parameters or by redundancy in the design of the sensor itself.

Attitude Error Sensor and Rate Switches

If an attitude error sensor failed and control failure in that vehicle axis developed, the vehicle deviations would have been sensed by the rate switch in that axis. Also, since such an indication was normally not limited to one axis, the sensors in the other axes would also signal abort.

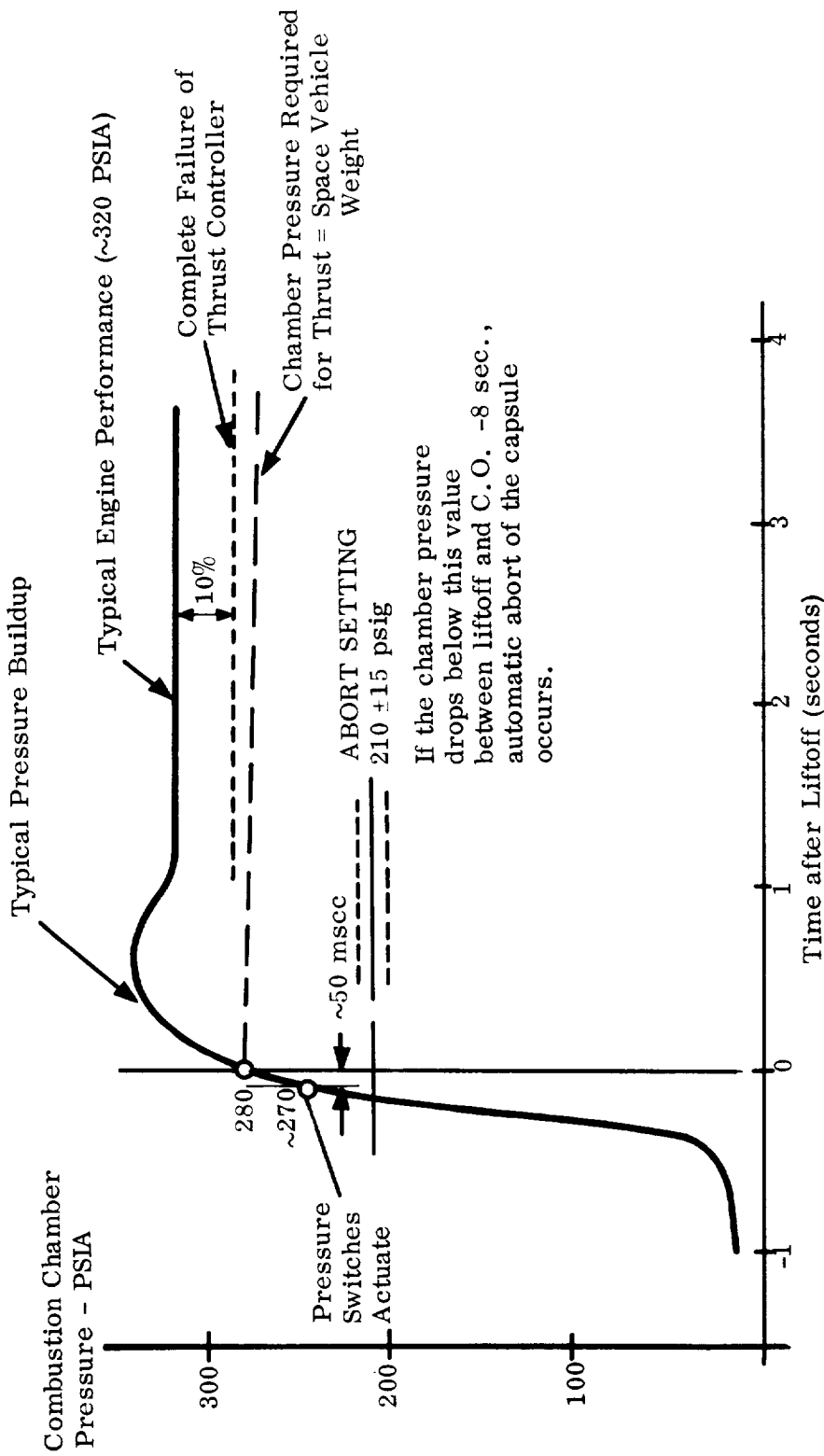

Note: Pressure switches are switched out of abort system at C.O. -8 seconds by Program Device.

Figure 5-2. Thrust Buildup

- Control Voltage Detectors

If the 60 volt dc control voltage was lost, and the control voltage detectors which sensed it failed, the LEV-3 attitude pickoffs would not have been able to sense vehicle attitude deviations and the vehicle would have gone out of control. In this case, the rate switches would still have been in operation since they were powered by the 400 cps power source.

- Combustion Chamber Pressure Switches.

Parallel switches were employed to assure engine monitoring in the event one pressure sensor failed.

5.2.5.3 Prevention of a False Abort Signal

A false abort command from a failed abort sensor precludes successful mission completion and subjects the astronaut to the hazards of high acceleration flight loads, aerodynamic buffeting and rescue from an off-nominal recovery area. In order to prevent abort from a sensor failure, the following provisions were made:

- Attitude Error Sensor

Since a certain voltage level from an attitude pickoff of the LEV-3 had to be supplied for operation of this sensor, a loss of this voltage would have made the sensor inoperative, and an abort signal would not have been given.

- Rate Switches

A mechanical spring kept the switch arm in the zero rate position. Closing of the switch contacts was possible only if the motor was running and the rate switch was turning around its sensitive axis at a rate above the set limits.

- Control Voltage Detectors

Two control voltage detectors were used in series and both would have had to indicate a voltage drop to a preset value before abort would have been initiated.

- Combustion Chamber Pressure Switches

When the combustion chamber pressure increased at mainstage engine ignition, the switches opened, actuated lock-in relays, and place the parallel pressure switches in the abort circuit. This lock-in feature prevented giving an abort signal if the switches did not open during thrust buildup and permitted ground monitoring of them up to liftoff.

Capsule-Launch Vehicle Electrical Interface

The Capsule-launch vehicle interface provided the means for the launch vehicle's 29 vdc to energize the capsule catastrophic failure detection relays. Loss of this voltage after liftoff would have initiated an abort signal. Two physically separate electrical interfaces were provided in order to prevent a false abort signal due to an interface wire connection break.

5.2.6 ABORT SIGNAL INITIATION AND SEQUENCING

The over-all system was designed to initiate abort signal:

By wire link before liftoff.

By radio link before and after liftoff.

By manual (astronaut) initiation after capsule umbilical drop.

By the launch vehicle inflight abort sensing system after liftoff.

These modes of abort initiation and the time sequencing used are shown in Figure 5-3 through 5-6.

As indicated in the figures, range safety considerations determined a major step in the sequencing. If an abort was required early in the flight (before T+30 seconds), the booster might have fallen on land if the abort signal was permitted to shutdown the engine in the normal manner. Thus, initiation of engine shutdown was limited to the Range Safety Officer during that period.

5.2.7 NETWORK AND SENSOR DESCRIPTIONS

5.2.7.1 Abort Network

The MERCURY-REDSTONE abort sensing network is shown in the preflight and inflight modes, Figures 5-7 and 5-8 respectively. The network consisted of three functional circuits: the Abort Bus (input signals), the Abort Relay (abort output signal), and the Engine Cutoff circuitry.

Abort Bus

The abort signals from all automatic sensors were connected to an abort bus. This bus would signal abort only through the abort relays (K7-1, -2, -3, and -4) after liftoff. Prior to liftoff abort command was sent to the capsule abort relays via hardwire, and the abort

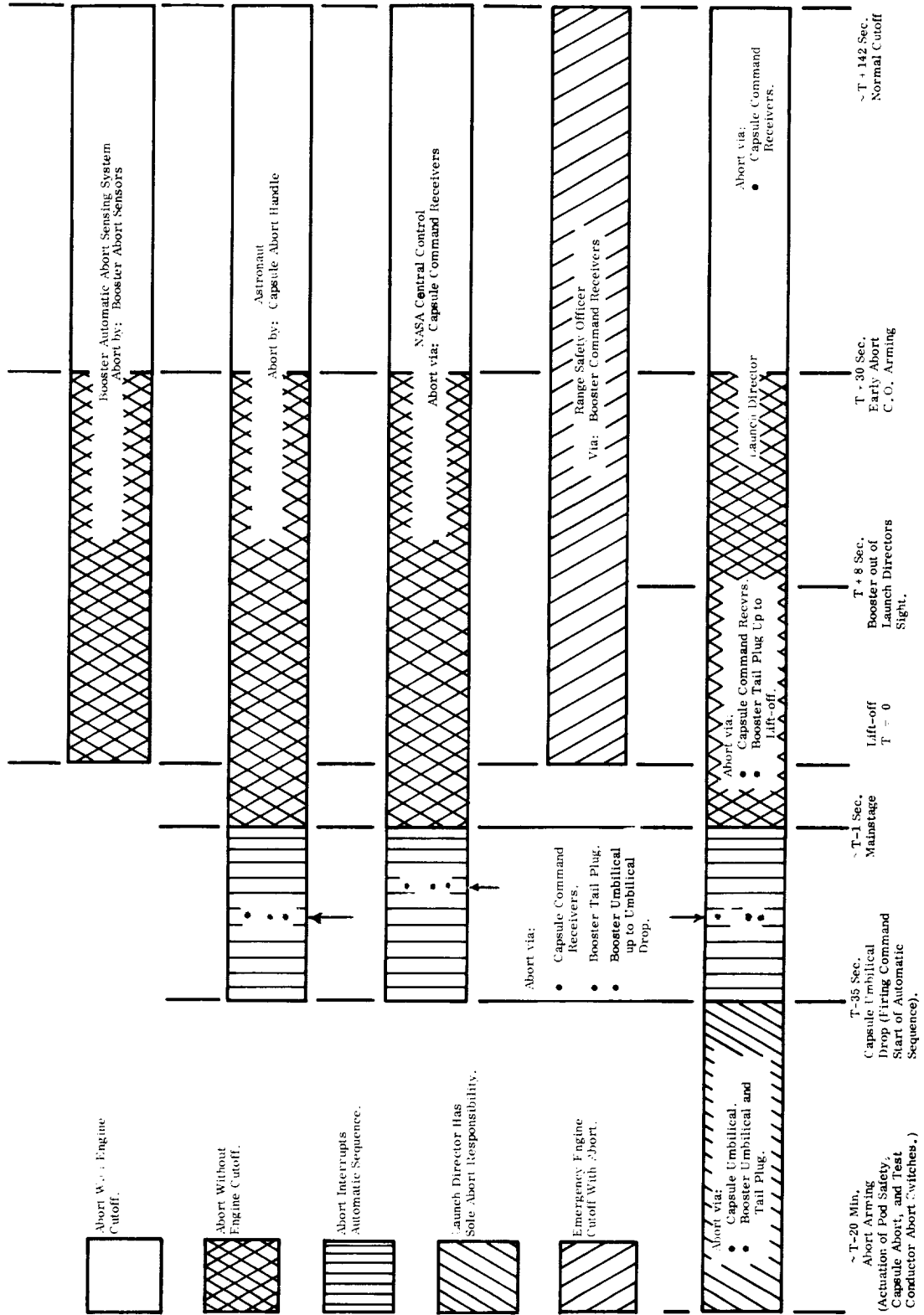
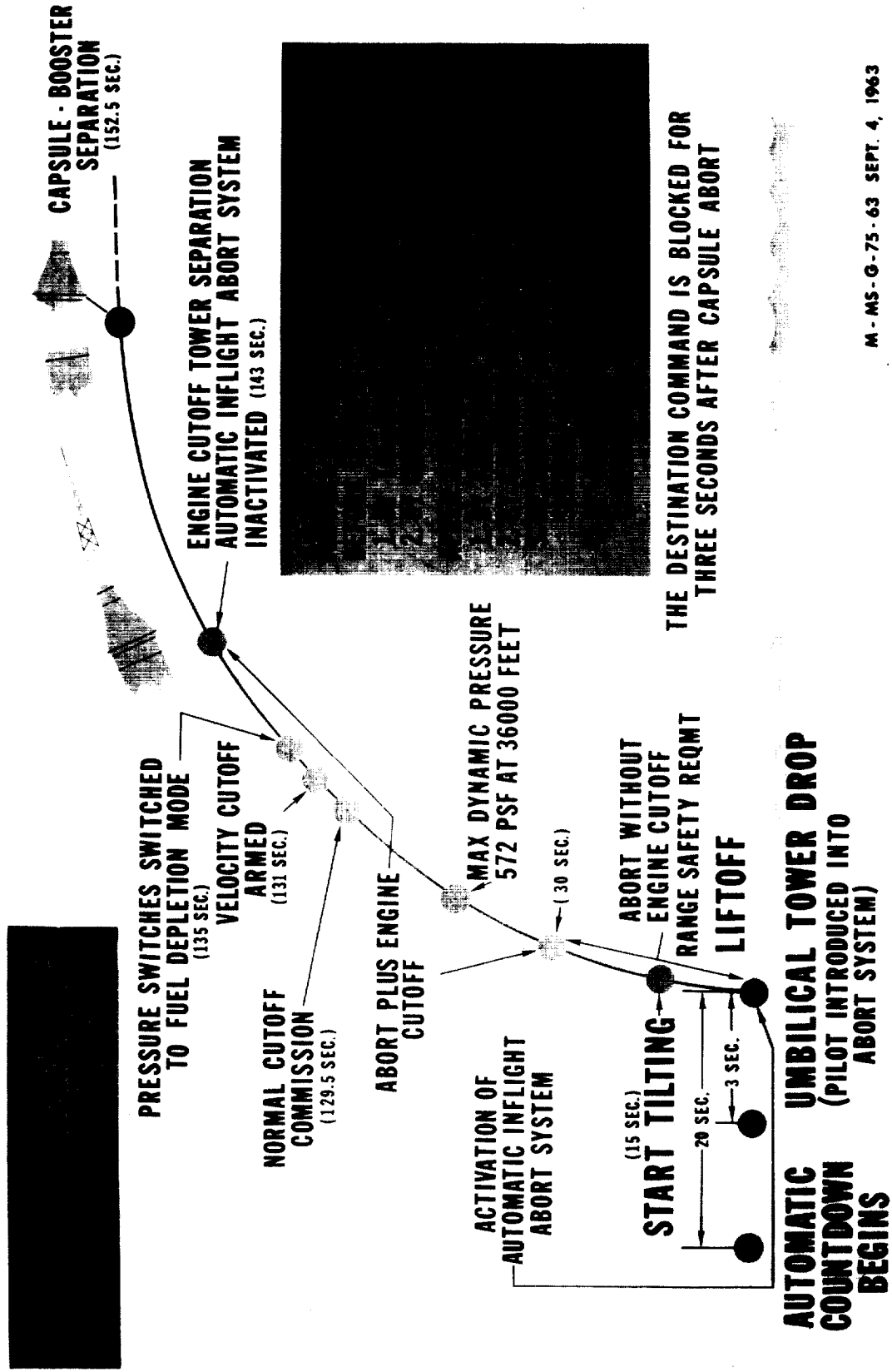

Figure 5-3. Abort Responsibility Assignments versus Time for Manned MERCURY-REDSTONE Mission



M - MS - G - 75 - 63 SEPT. 4, 1963

Figure 5-4. MERCURY-REDSTONE Booster Flight

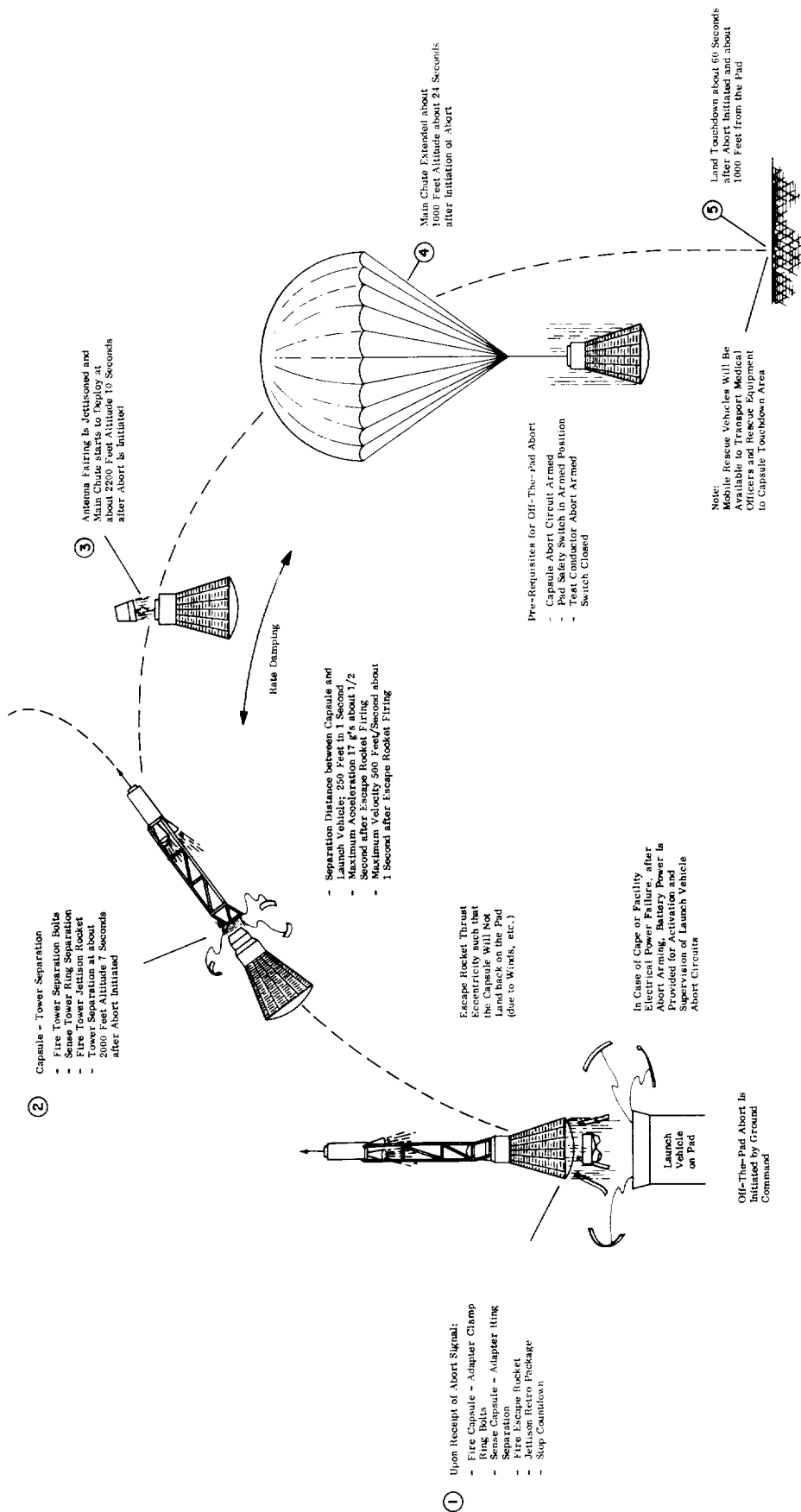

Figure 5-5. Off-The-Pad Abort

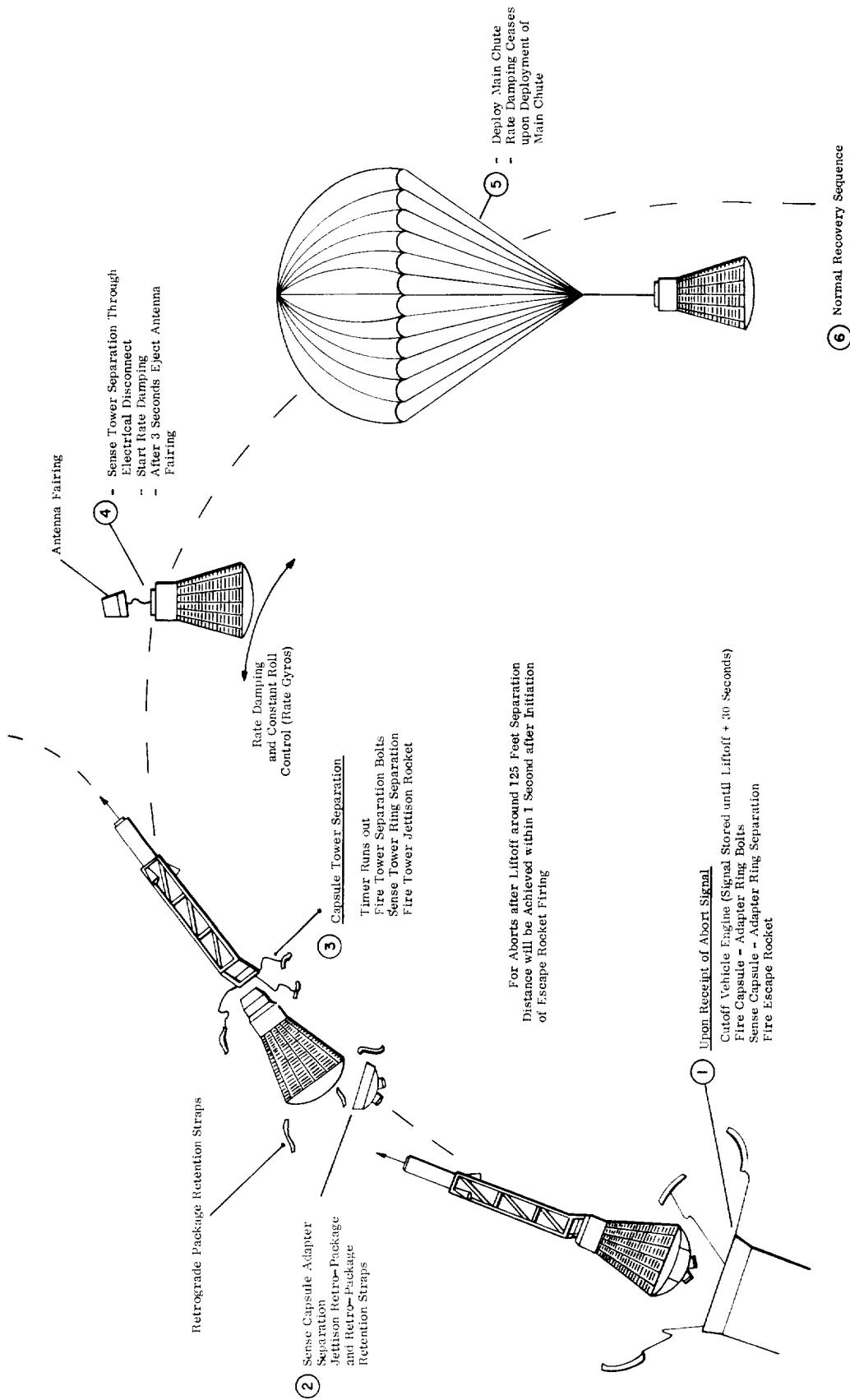

Figure 5-6. Abort After Liftoff up to Normal Engine Cutoff

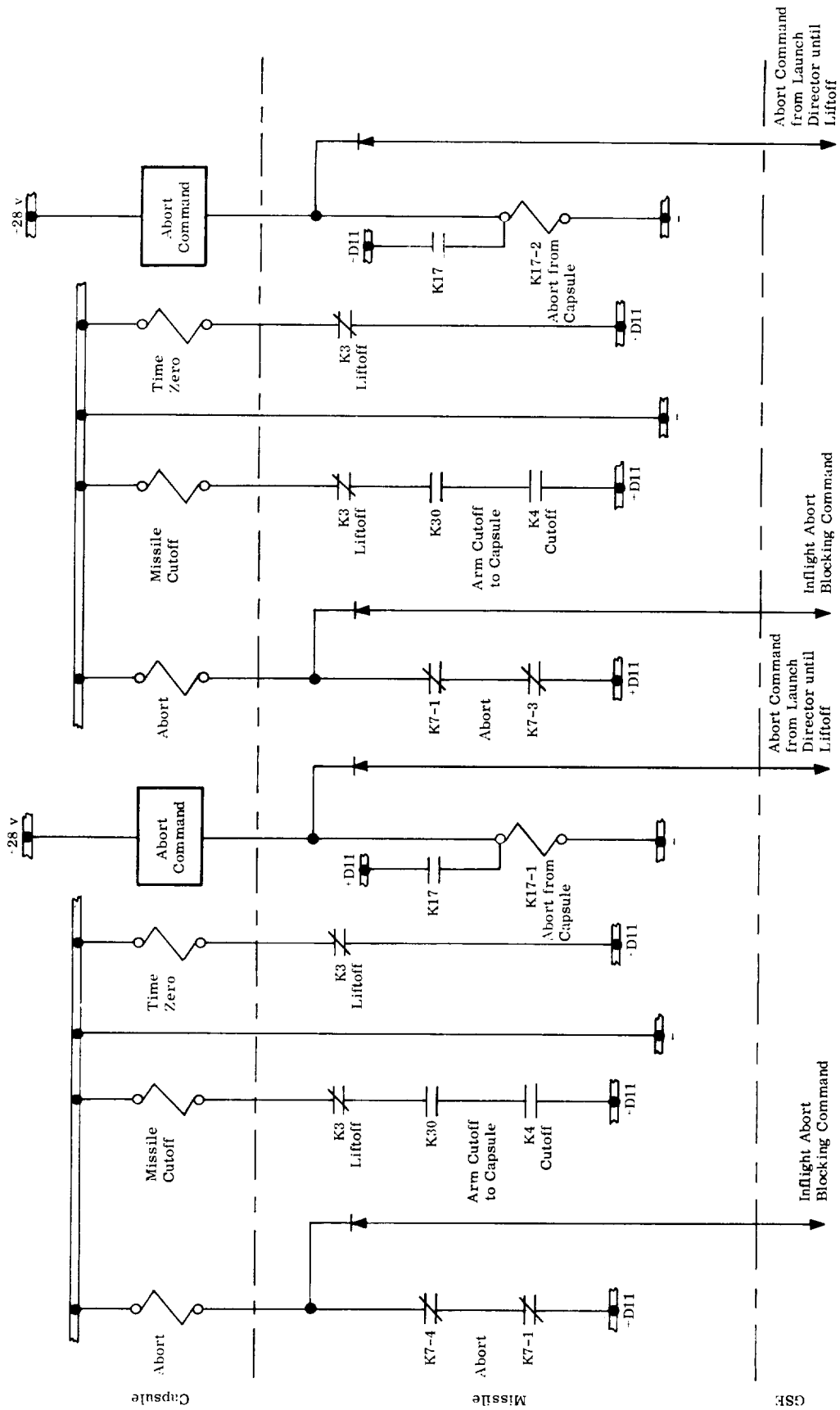

Figure 5-7. Preflight Abort Network Schematic Diagram

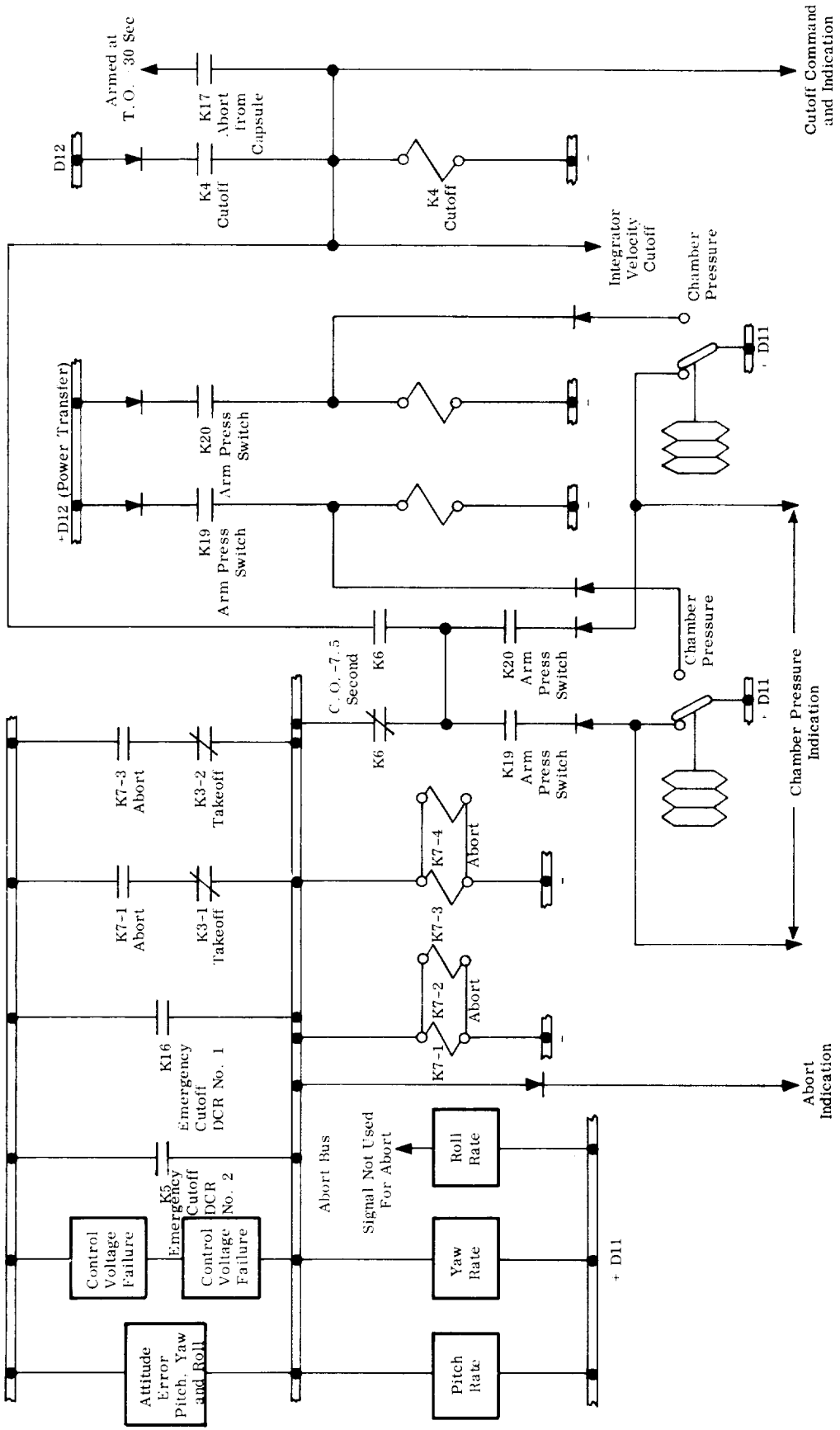

Figure 5-8. Inflight Abort Network Schematic Diagram

bus was monitored by ground support equipment. For safety and as a final check, the launch sequence was blocked if an abort condition existed in the automatic system prior to liftoff.

a. Attitude Error Sensor

This device monitored the output of the gyro system in pitch, yaw, and roll. If any of the attitude angles exceeded the specified limit, a signal was sent to the abort bus.

b. Rate Switches

The three rate switches were mounted in the pitch, yaw, and roll axes. If excessive angular movements occurred in the pitch and yaw axes, a signal was given to the abort bus. The roll rate signal was only monitored by telemetry and did not have energize the abort bus.

c. Control Voltage Detector

If the 60-volt control voltage supply dropped below 50 volts, the voltage sensors gave a signal to the abort bus. Two sensors were used and both had to indicate failure before the abort signal could pass to the abort bus.

d. Combustion Chamber Pressure Switches

Two pressure switches were mounted on the engine to sense chamber pressure. With a rise in chamber pressure, the switches actuated, locking in relays K19 and K20, and placed the chamber pressure switches in the abort circuit. This lock-in feature prevented aborts due to nonactuation (failure) of the switches during thrust buildup. The two switches were in parallel circuits to eliminate the possibility of an abort signal not being given due to a failure of one of the switches after liftoff. At approximately "calculated cutoff minus eight seconds," K6 actuated, switching the pressure switches from the abort to the normal cutoff circuit. This was necessary to prevent an abort during normal shutdown.

e. Emergency Cutoff by Range Safety Officer

Engine cutoff by the Range Safety Officer was prohibited until 30 seconds after liftoff. At that time relays K5 and K16, not shown on the schematic, "dropped out" the engine main stage relay, thus permitting cutoff. These two relays were employed to provide redundant signal paths for cutoff.

abort. Relays K5 and K16, the two emergency cutoff relays, were operated by command receiver No. 1 and command receiver No. 2, respectively, and like the command receivers, were powered from independent 28-volt supplies. These relays triggered the abort bus and started two timers which blocked the fuel dispersion (destruct) system for three seconds after receipt of an emergency cutoff command. This eliminated the possibility of fuel dispersion before an attempted abort.

f. Capsule Abort

If the astronaut initiated an abort, the signal opened contacts K17-1 and K17-2, which initiated abort and engine cutoff as stated above, cutoff was blocked until after liftoff.

All wires which supplied abort signals or power from the launch vehicle to the capsule were duplicated for redundancy.

- Abort Relay

The abort contacts K7-1, -2, -3, and -4, were tied directly to the abort bus. Contacts K7-1 and K7-3 provided the lock-in feature to the abort bus when liftoff relay, K3, was de-energized. Once the abort bus was energized from any of the abort sensors, the bus locked-in if the vehicle had moved 3/32 of an inch, an amount sufficient to de-energize the liftoff relay. Abort could also be initiated up to liftoff by command from the ground through a hardwire connection to the capsule. After liftoff, ground command of abort could only be given through the capsule command receivers. The abort relay gave an abort signal directly to the capsule and would initiate engine cutoff 30 seconds after liftoff. As an additional safety feature the vehicle electrical system supplied the capsule a constant 28-volt signal through the series-normally-closed contacts of K7-1 and -2, K7-3 and -4. This inadvertent loss of electrical power to assured abort by removing power from the abort circuit to the capsule.

- Engine Cutoff

Engine cutoff could be initiated by six sources subsequent to liftoff plus thirty seconds:

- a. Abort (by energizing the command receiver relays).
- b. Integrator velocity cutoff.
- c. Propellant depletion (by means of combustion chamber pressure switch within 8 seconds of calculated cutoff).

- d. Abort from capsule
- e. Cutoff command from Launch Director (until liftoff).
- f. Emergency cutoff by Range Safety Officer.

5.2.7.2 Attitude Error Sensor

The function of the attitude error sensor was to actuate the abort bus if the vehicle deviated beyond prescribed limits in pitch, yaw, and roll attitudes prior to engine cut-off. Three bi-stable voltage sensing triggers, each with two independently adjustable OR-type inputs were used. The input signals were derived from the potentiometer pickoffs on the LEV-3 gyros, and the sensor output actuated the abort circuit.

- Design Requirements
 - a. Supply voltage on 28 volts dc \pm 10 percent.
 - b. Reference voltage 50 to 60 volts dc.
 - c. Temperature range 0^oC + 55^o C.
 - d. Vibration (reference Paragraph 5.3.3).
 - e. Input impedance 50 K ohms or greater shunted by no more than 0.005 microfarads of capacitance.
 - f. Minimum response time of 10 milliseconds.

- Abort Limits and Tolerances

Abort Limit		Tolerance
Pitch	5 degrees	Plus 1.0 degree, minus 0 degree
Yaw	5 degrees	Plus 1.0 degree, minus 0 degree
Roll	10 degrees	Plus 2.0 degree, minus 0 degree

- Circuit Description

The basic circuit is shown in the block diagram, Figure 5-9. Each gyro had two potentiometers mechanically connected to rotated in opposite directions. The difference in potential between the sliders furnished a signal corresponding both in magnitude and polarity to gyro rotation. Identical polarity triggering circuits compared the signal from each slider with respect to ground, and determined when the limits of rotation in each direction were reached.

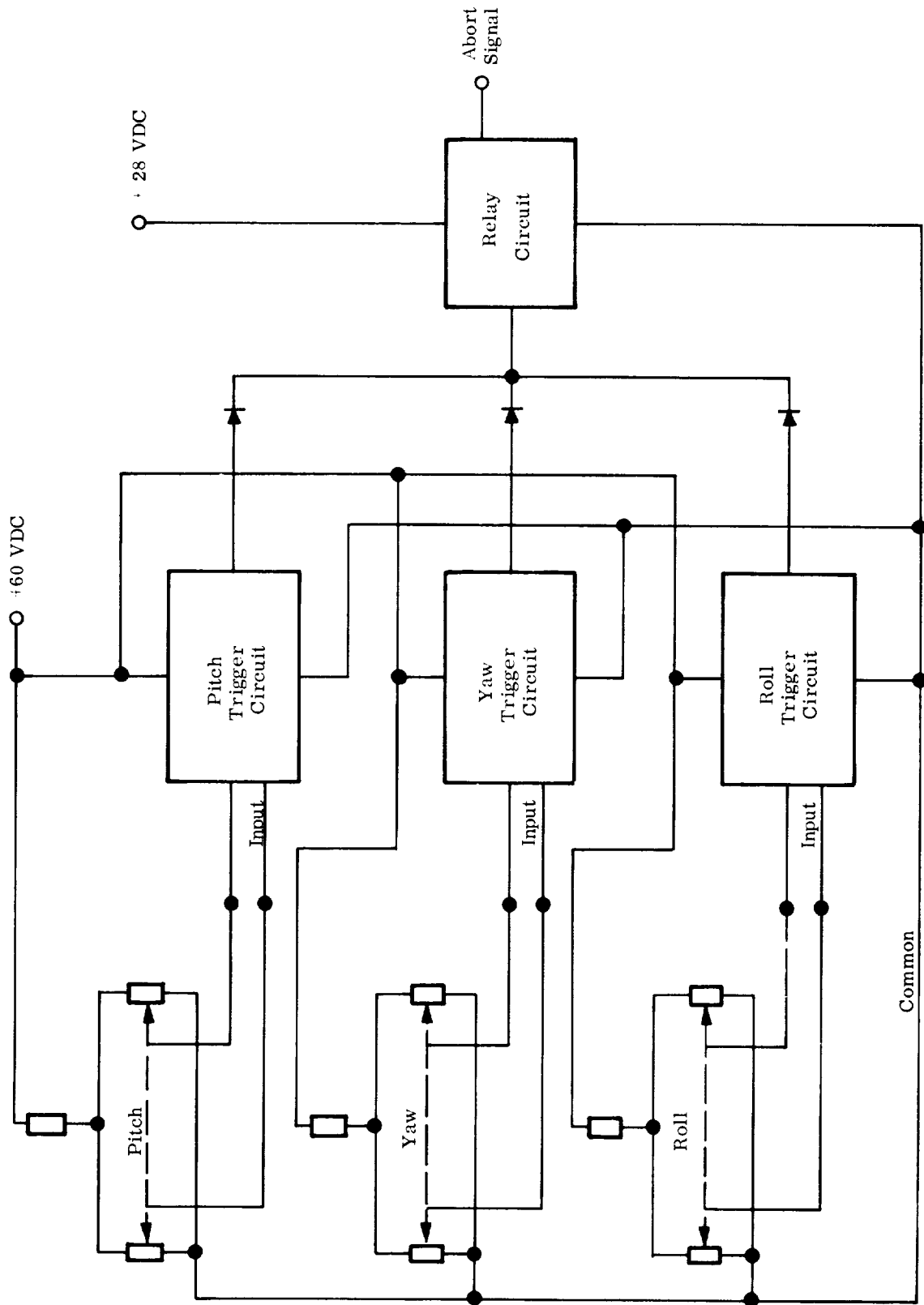

Figure 5-9. Attitude Error Sensor Block Diagram

The trigger input circuit consisted of a PNPN gated-diode used as a voltage sensing element which was turned on or off by varying the base (gate) voltage. The trigger voltage point (abort limit) was set by varying the emitter bias. The trigger input was part of a unijunction transistor oscillator circuit. Output from the oscillator was rectified and amplified to operate a relay with contacts in the abort circuit.

Circuit details may be seen on the schematic diagram (Figure 5-10). The cathode of the PNPN diode was biased such that when the desired input voltage was reached the PNPN diode conducted in the forward direction causing the unijunction oscillator to operate. Oscillation was sustained until the input voltage was reduced below the PNPN diode turn-on value. The diode in the emitter circuit provided reverse voltage protection for the PNPN diode. The potentiometer in the emitter circuit was used to adjust the operating point to the desired (abort) level. Complete voltage compensation for varying supply voltages was achieved by use of a zener diode and potentiometer in the reference circuit. The zener diode acted as the constant voltage source, and potentiometer adjustment provided compensation for large variations in supply voltages. A thermistor and resistor combination in the reference voltage network provided temperature compensation.

Oscillator output was capacitor-coupled to a rectifier circuit. The coupling diodes in the rectifier circuit prevented changes in trigger level or oscillator operation due to voltage variations and dc level changes in the relay circuit. The rectified output was fed to a dc amplifier stage that powered the relay which energized the abort circuit. The capacitor in the base circuit of the amplifier provided a time delay. This precluded an abort signal arising from transients above the sensor limits by requiring the oscillator to sustain operation for a sufficient time to charge the capacitor. The resistor and diodes provided bias and temperature compensation. The relay in the collector circuit was shunted by a capacitor and diode to remove transient voltage spikes that occurred when the circuit was de-energized.

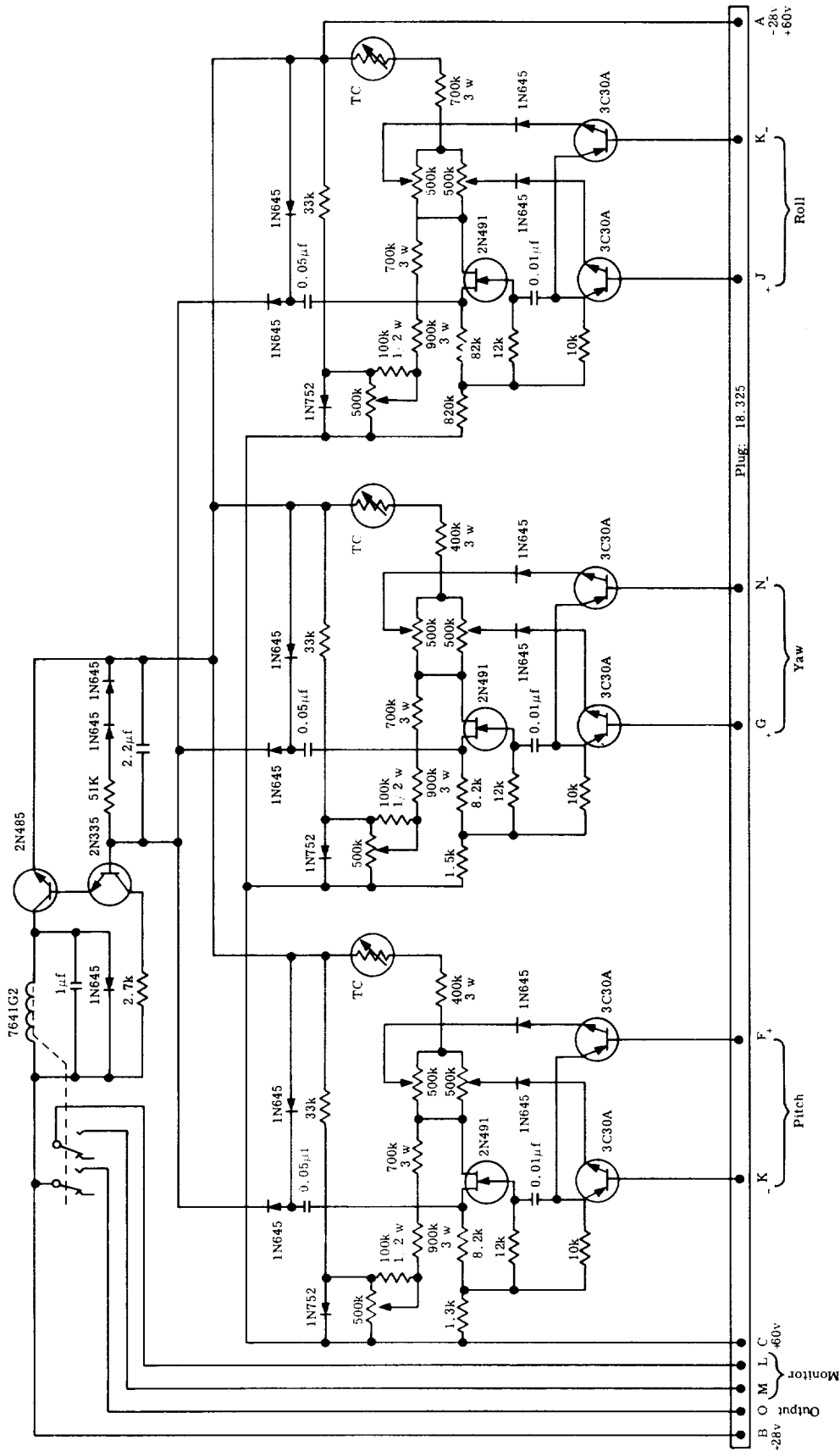

Figure 5-10. Attitude Error Sensor Circuit

- Failure Consequences

Failure of the following attitude sensing components could have caused an abort:

- a. Open circuit input.
- b. Short circuit of the PNP diode.
- c. Short circuit of the coupling capacitor between oscillator and dc amplifiers.
- d. Short circuit of either transistor in the output.
- e. Open or short circuit of the resistors or diodes in the reference network.

Loss of either 28 or 30 volts power within the sensor circuit would not have caused an abort, nor would failure of any component not mentioned above.

5.2.7.3 Attitude Rate Switches

The rate switch (figure 5-11) was a spring-restrained, miniature gyroscopic device operating to close a set of contacts at a predetermined angular rate of turn. It was capable of sensing angular rates CW or CCW about its input axis. Units were mounted to indicate changes in pitch, yaw, and roll attitude. Yaw and pitch rate switches built for MERCURY-REDSTONE were designed to close at attitude rates of 5 degrees per second; the roll switch closed at a roll rate of 12 degrees per second. Tolerances on the pitch and yaw rates were plus 0.3 degree per second, minus 0 degree per second and on the roll rate were 0.6 degree per second, minus 0 degree per second.

Three separate switches were used to sense motions of the vehicle in the pitch, yaw, and roll axes. Only the pitch and yaw rate switches were used to signal abort. The roll rate switch output was used only for monitoring that performance parameter.

The rate switches consisted of a gyro supported on bearings, a viscous damping device, and switch contacts. The gyro's gimbal displacement was proportional to angular velocity (or rate) about its sensitive axis. In the absence of an angular velocity about the input axis, the gimbal displacement was zero. The gyro used a single pole, double-throw switch which closed at the abort limits.

Motor power was 115 volts 400 cps. In the event of power failure, the angular momentum of the gyro was sufficient to insure operation for several minutes; however;

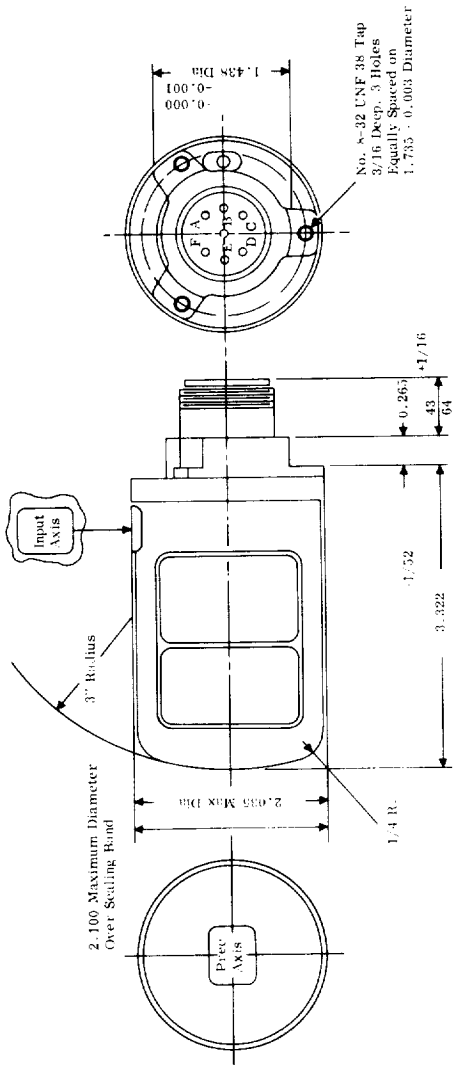

Mechanical Data

Unit No. TI905-1A-15 and TI905-2A-15 TI905-1B-15

Closing Rate 12 /Min. to 17 /Min. 12 /Min. to 18 /Min.

Temperature Range -54°C to +71°C

Weight 1.5 Pounds Max.

Electrical Data

Power Requirements
Motor: 115 v., 400 cps., 3 Phase
Heater: 28 v., Direct Current

Power Consumption
Motor Starting Power 110 watts (max.)
Volt Amps - 19.0 v.a. (max.)
Motor Running Power - 5.5 watts (max.)
Volt Amps - 14.0 v.a. (max.)
Heater: 30 watts (intermittent)

Warm Up Time
4 minutes below 25°C
1.5 minutes above 25°C

Specifications

Type TI905-1A-15 TI905-1B-15 TI905-2A-15

Rate of Turn 43 /Min. 90 /Min. 43 /Min. 90 /Min. 43 /Min. 90 /Min.

Contacts Reopen Within 5 Sec. 6 Sec. 3 Sec. 4 Sec. 5 Sec. 6 Sec.

Motor: Angular momentum 3x10 gm-cm /sec.
Speed 24,000 rpm
Time to reach synchronous speed - 30 seconds

Operating Life: 1000 hours
Shelf Life: 5 years

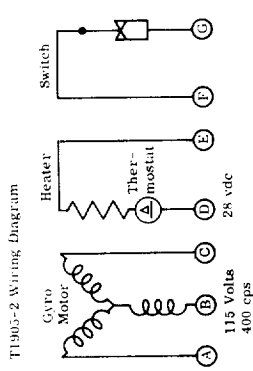
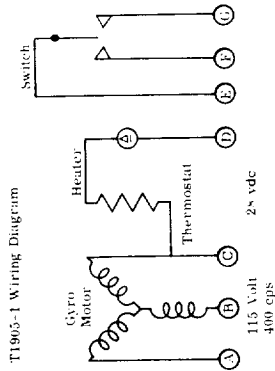

Figure 5-11. Attitude Rate Switch

there would have been a slight increase in the angular velocity required to give the abort signal. Also, if the gyro failed, the switch contacts would have remained in the open position and would not have caused abort.

All electrical connections were brought out through a hermetically sealed connector located on the end of the housing.

The rate switches were hermetically sealed in an environment consisting of a dry inert gas which prevented corrosion. The switches had a minimum operating life of 1000 hours. The switch springs were of low hysteresis material, and the bearings were selected for their ability to retain low friction characteristics, thus assuring a high degree of accuracy and resolution throughout their operating life. The switches were built to withstand vibrations between 20 and 2000 cps.

A rate switch monitor was in series with the output of the rate switches and was used to give an indication to telemetry when an abort, caused by the switches, had occurred. It had no function in the abort sensing system except as a telemetry transducer.

The rate switch was connected as shown in Figure 5-12. The switch contact, when closed by excessive angular rates applied 28 vdc to the abort bus through a diode, and to telemetry through the second diode and a voltage divider in the measuring distributor. If the abort bus was energized by any of the other sensors connected to it, the diodes blocked this signal from the rate switch telemetry readout. The rate switch monitor circuit diagram is shown in Figure 5-13.

5.2.7.4 Control Voltage Detector

The attitude error signals from the potentiometer pickoffs of the LEV-3 gyros depended upon the 60 volt dc control voltage. Loss of this voltage would have resulted in loss of control of the vehicle and loss of the abort sensing system's attitude error sensor. For the MERCURY-REDSTONE abort sensing system, it was decided to monitor this supply voltage to assure that the absence of an abort signal from the attitude error sensor did not cause a serious decrease in or loss of control voltage potential.

Although at the initiation of the MERCURY-REDSTONE Program, the exact circuitry anticipated for the control voltage detector had not been used, very similar circuits had been employed for delay timer applications in other systems. The timers had

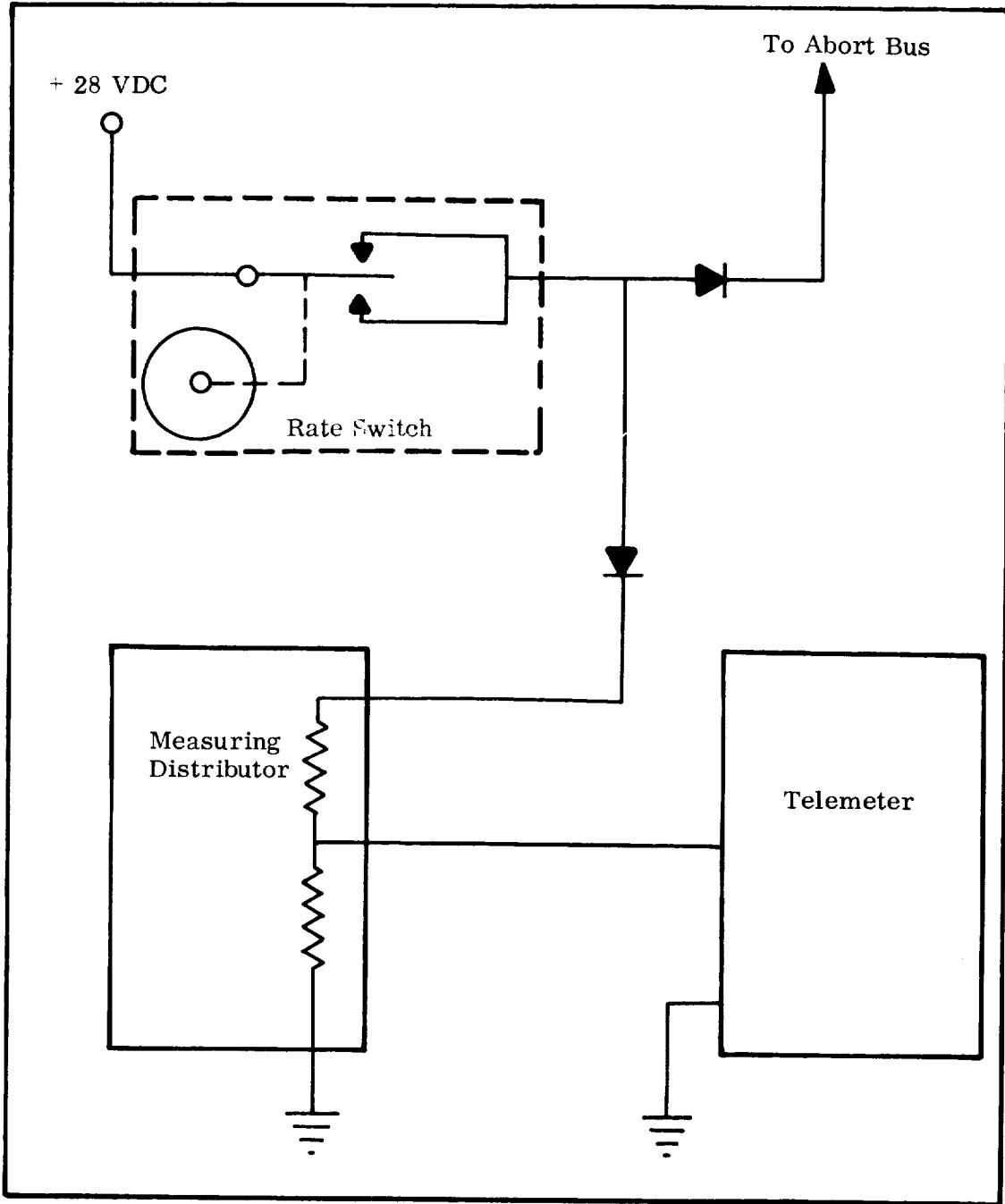

Figure 5-12. Attitude Rate Switch Block Diagram

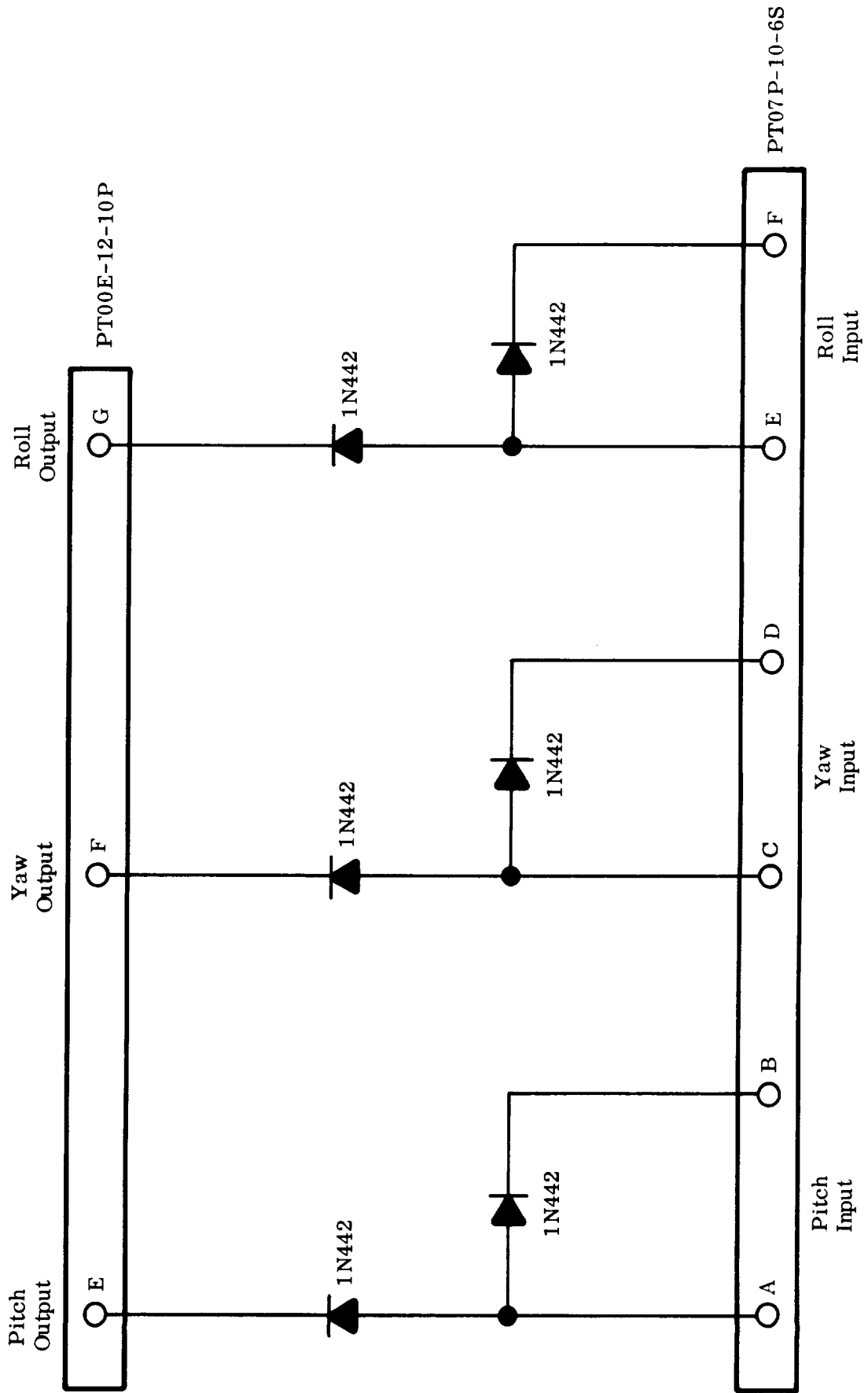

Figure 5-13. Attitude Rate Switch Circuit

been extensively tested to JUPITER environmental requirements. Three such timer units per missile (separation timers and reverse thrust timer) had been employed with excellent success in every JUPITER missile since AM-9. In addition, similar circuitry had been used successfully as shroud timers in the JUNO II program, as pod timers in the HARDTACK program, and as ground voltage sensors in the JUPITER system.

Detailed performance tests were conducted by Quality Division prior to use of the control voltage detector in the MERCURY-REDSTONE system. Six of the Units were environmentally tested and all six units performed satisfactorily within launch vehicle specifications. The deviation from design specifications was at low temperature (0°F). The differential voltage between pickup and dropout fell below one volt on three of the test units. The temperature extreme was far below launch site temperatures, and the deviation was not considered relevant to the vehicle mission (reference paragraph 5.3.3).

The control voltage (30 volt dc nominal) was monitored by a voltage divider network which drove a bridge circuit formed by CR2, R6, CR3, and R10 (Figure 5-14). This bridge circuit, dependent upon the sensed voltage, was balanced or unbalanced. If the sensed voltage remained within its specified 60-volt range, the bridge circuit was unbalanced and transistor Q1 conducted driving transistor Q2. Conduction by the transistors maintained the output relay in the energized position. A drop of the sensed voltage to 50 volts drove the bridge into a balanced stage causing Q1 to be cut off. Positive feedback action of resistor R-7 accentuated the cutoff action and maintained the transistor circuitry in cutoff condition. With Q1 and subsequently Q2 cutoff, the output relay was immediately de-energized actuating abort circuitry. For voltages below 50 volts the bridge circuitry became unbalanced in such manner as to cause the transistors to be biased to cutoff.

The control amplifier was a medium power, silicon transistor stage which functioned as an on-off switch for the output relay. Sharp triggering of this stage provided snap-off operation of the output relay at the critical input level.

Capacitors, C-1 and C-2, assured that circuit operation would not be adversely affected by voltage transients. Design criteria required a delayed action of approximately 100 milliseconds in order to compensate for negative voltage transients. Unless this delay was included, the control voltage detector would detect and initiate an abort signal as a result of a negative transient.

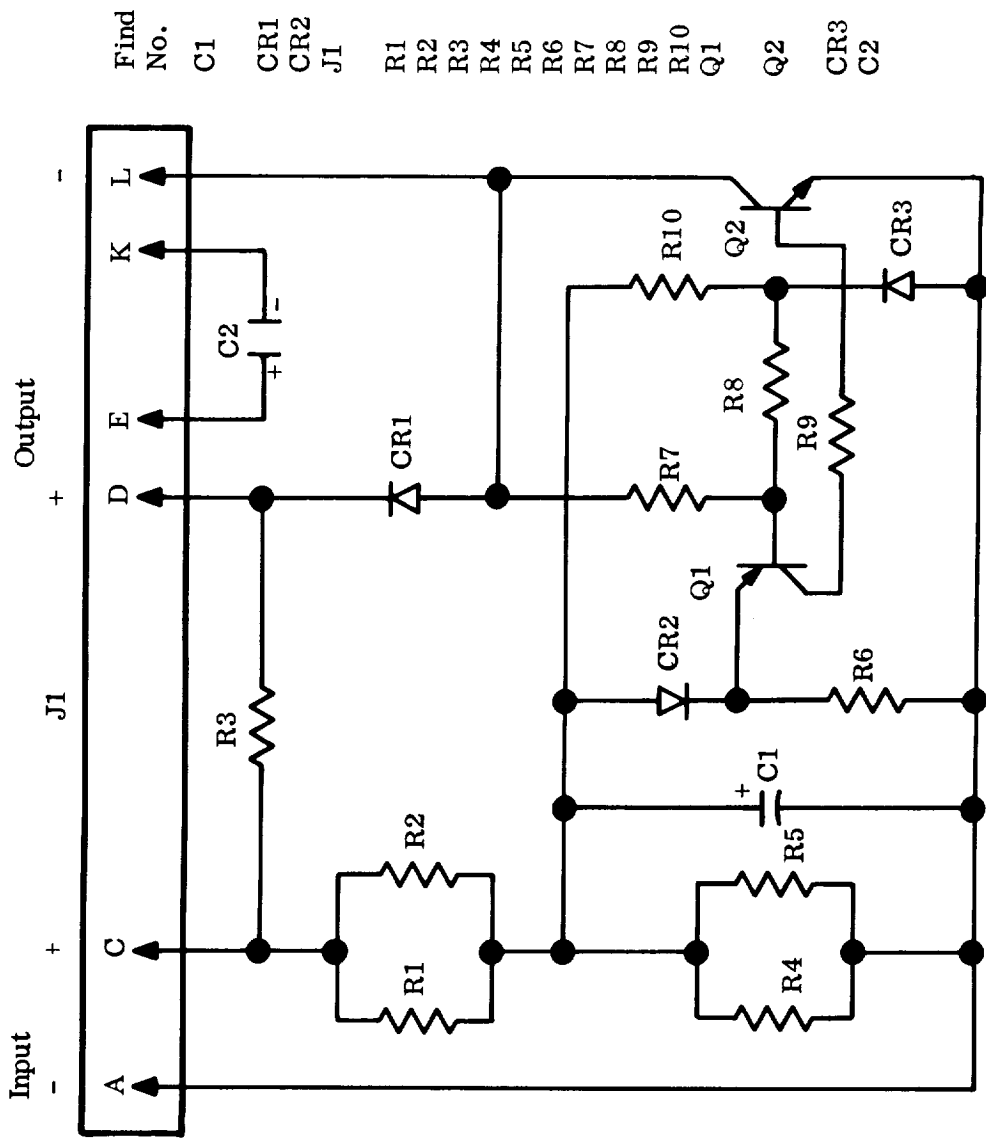

Electrical Components List

Find No.	Description
C1	Capacitor, Solid Tantalum, 55 MFD 25 vdc, 4T304
CR1	Diode, Submin Silicon 1N457, 60 Volts PIV
CR2	Diode, Zener Regulator SV132
J1	Connector, 10 Pin Male, Printed Circuit, No. 4202
R1	Resistor, 2K, 3 Watt, 10 Percent
R2	Resistor, 2K, 3 Watt, 10 Percent
R3	Resistor, 700 Ohm, 3 Watt, 10 Percent
R4	Resistor, Test Select, 1 Watt
R5	Resistor, Test Select, 1/2 Watt
R6	Resistor, 1.2K, 1/2 Watt, 5 Percent
R7	Resistor, Test Select, 1/2 Watt
R8	Resistor, 4.7K, 1/3 Watt, 5 Percent
R9	Resistor, 1.9K, 1/3 Watt, 5 Percent
R10	Resistor, 1K, 1/3 Watt, 5 Percent
Q1	Transistor, Silicon Junction 2N1026
Q2	Transistor, Silicon Junction 2N498
CR3	Diode, Zener Regulator SV132
C2	Capacitor, Tantalum, 60 MFD 50 vdc, VP60840A1

Figure 5-14. Control Voltage Detector Electrical Schematic

Capacitor, C-1, provided a time delay of 50 milliseconds for a negative voltage transient of 20 volts. Capacitor, C-2, across the relay coil increased the time delay to the required 100 milliseconds.

When the control voltage was in the safe range, the output relay was energized and the output contact was open.

However, when the control voltage dropped below the critical 50 volt level, the control amplifier de-energized the relay causing 28 volts dc to appear at the output through a set of normally closed contacts. This mode of operation required both safe input voltage and proper circuit operation for no output signal.

To assure maximum safety and reliability, the circuitry of the control voltage detector was designed so that all components were used at power levels well below their rating. To prevent a false abort, two detector circuits were used in series thus allowing one to block the abort signal if the other detector should fail.

5.2.7.5 Chamber Pressure Sensor

The combustion chamber pressure was monitored with two redundant pressure switches. These switches were mounted on the thrust frame with chamber pressure supplied to them by independent pressure tubes.

When pressure was applied to the switch, Figure 5-15, the force developed on the diaphragm was transmitted through a preloaded spring to a microswitch. Increasing pressure actuated the microswitch and armed the pressure switch. Subsequent decreasing pressure would deactivate the microswitch and cause an abort signal. The preloaded spring controlled the arm and abort actuation points and was adjusted as shown in Figure 5-2.

The method of sequencing assured proper engine operation prior to arming the switch and prevented false abort in the event of pressure fluctuations during thrust buildup. Since any loss of pressure would signal an abort, the pressure switches were switched out of the abort circuit prior to a normal engine cutoff.

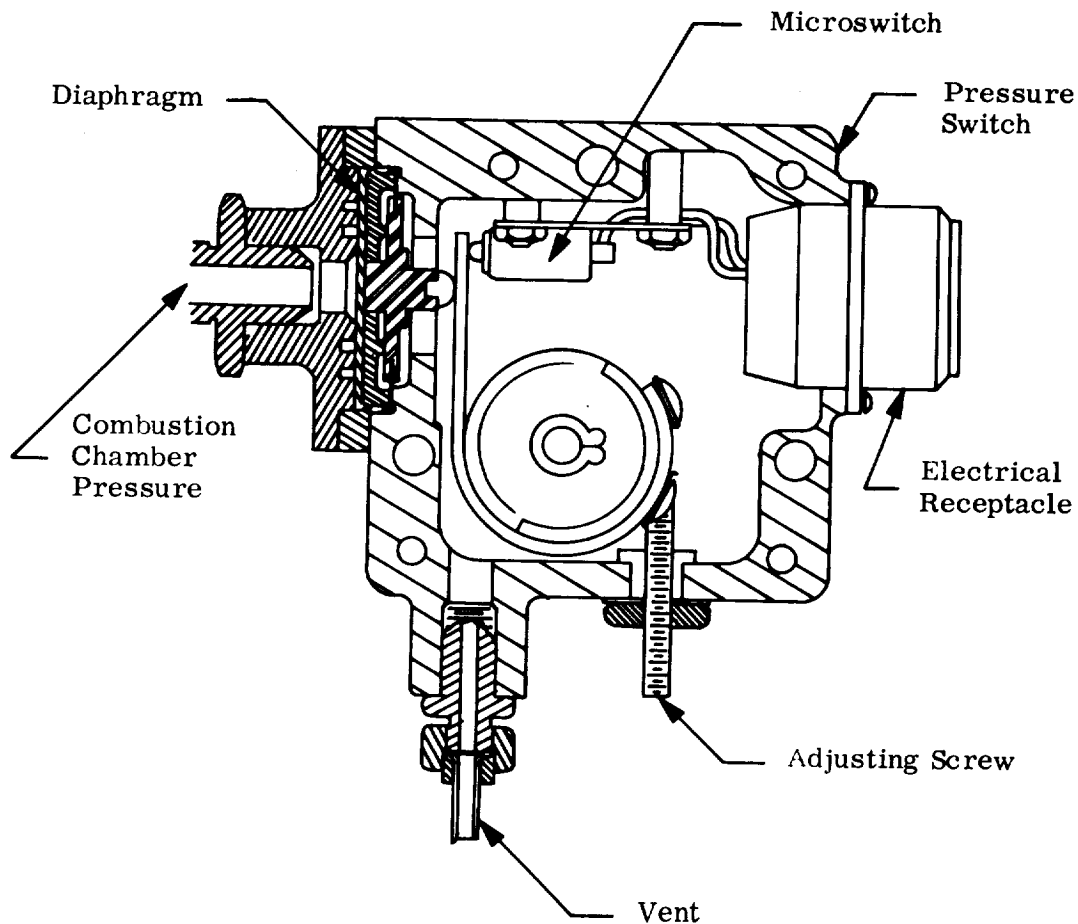

Figure 5-15. Chamber Pressure Sensor

5.3 RELIABILITY PROGRAM

5.3.1 INTRODUCTION

It was evident at the beginning of the program that mission reliability had to be increased above that indicated by the tactical missiles. Since the REDSTONE had an extensive flight history, many of the weak areas of its design and performance had been identified and improved. In contrast, the abort system and capsule interface were new. A reliability program was thus established to upgrade the booster and assure the proper operation of the new components.

5.3.2 RELIABILITY TESTING

A developmental test program was conducted to prove the REDSTONE's adaptation to the MERCURY Program. A major portion of this test program was called the MERCURY-REDSTONE Reliability Program. The successful program found potential

problem areas, developed satisfactory solutions, and established procedural and quality standards. Tests in the total program included the following:

- Factory Testing
 - a. Aft section tests including abort system.
 - b. Tail section tests.
 - c. Propulsion subsystem tests.
- Structural Load Simulation
 - a. Thrust unit flight simulation.
 - b. Transportation load simulation.
- Static Firing - Noise and Vibration
- Capsule and Adapter
 - a. Mating compatibility test.
 - b. Flight adapter checkout.
 - c. Separation ring test.
- Component Qualification and Development Tests.

The factory testing was a combined temperature-humidity-vibration test series conducted by Chrysler Corporation's Missile Division (CCMD). Also conducted by CCMD were the structural load simulation tests on the thrust unit. This test included application of bending, shear, and longitudinal loads simulating flight and transportation loads.

A static firing test conducted by MSFC measured noise and vibration at several points on the missile, adapter, and capsule. Functional and mating compatibility tests were also made at MSFC with the capsules for MR-1 through MR-BD. A checkout was made on each flight adapter starting with the adapter for MR-3. In addition several component development and qualification tests were made to solve individual problem areas and prove flight readiness. The details of these tests and their results are described in Section 6.

Of special note was a total system-environment test of the Instrument Compartment containing the abort sensing system. The test was made on a specially designed "rock and roll" test fixture, formally named the Vertical Test Fixture (Figure 6.3). This was probably the biggest and most important ground test effort of the program. The abort

system was operated under actual angular rates and attitude changes, coupled with vibration, humidity and temperature environments. Additional details are given in Section 6.3.3.

5.3.3 ABORT SYSTEM RELIABILITY TEST PROGRAM

Of special interest was the program designed to assure a high abort system reliability. The plan for this program is presented here.

The plan called for testing of systems and subsystems. In addition to testing large groups of components simultaneously, this method had the advantage of testing the various components and their interaction. Such tests were conducted at the Chrysler plant. In addition, qualification tests were conducted for each component of the abort system at MSFC.

Using three or more units of each of the components composing the abort system, a modified test-to-failure program was to explore the modes of failure, environmental levels of failure, and critical operation and environmental conditions. The purpose of the tests was to isolate any mode of failure so that necessary corrective action could be taken. The tests were designated as follows:

- First Level

Each component was tested under those environments expected prior to and during flight.

- Second Level

Each component was stressed operationally and environmentally at the expected maximum capability of that particular component.

- Each component was stressed under a predetermined critical environment until failure occurred.

Actually two test plans were developed which differed only in the levels of temperature, vibration, shock, and acceleration. Plan A (Table 5-4) was designed for the rate switches, voltage detectors, and attitude error sensors. These were contained in the pressure and temperature controlled instrument compartment. Plan B (Table 5-5) was designed for the combustion chamber pressure sensors because of their location on the engine.

Table 5-4

Abort Sensing System Reliability Test Plan A for Attitude Rate Switches,
Attitude Error Sensors, and Voltage Detectors*

Environment	First Level	Second Level	Third Level
Low Temperature	+ 50 ^o F	0 ^o F	- 25 ^o F and +77 ^o F
High Temperature	+120 ^o F	+145 ^o F	+160 ^o F and +77 ^o F
Vibration	20 to 50 cps at 0.03 inch double amplitude 50 to 2000 cps at 4 g.	20 to 50 cps at 0.06 inch double amplitude 50 to 2000 cps at 8g.	20 to 50 cps at 0.09 inch double ampli- tude 50 to 2000 cps at 12 g. Repeat with g increased by 4 g increments un- til failure.
Shock	10 g	20 g	30 g
Acceleration	10 g Longitudinal 5 g Lateral	20 g Longitudinal 10 g Lateral	30 g Longitudinal 15 g Lateral
* The number of samples tested were 6, except, only 3 attitude error sensors were tested due to component availability.			

Table 5-5

Abort Sensing System Reliability Test Plan B for Combustion Chamber
Pressure Sensors (6 Samples)

Environment	First Level	Second Level	Third Level
Low Temperature	_____	Same as in Table 5-4	_____
High Temperature	_____	Same as in Table 5-4	_____
Vibration	20 to 100 cps at 0.04 inch double amplitude 100 to 2000 cps at 20 g.	20 to 100 cps at 0.06 inch double amplitude 100 to 2000 cps at 30 g.	20 to 100 cps at 0.08 inch double ampli- tude 100 to 2000 cps at 40 g.
Shock	25 g	30 g	40 g
Acceleration	_____	NONE	_____

As shown in the tables, both plans call for temperature excursions. For these tests the equipments were to be stabilized at the indicated temperature, then soaked at this temperature for 2 hours prior to running functional tests. The third level test was really two tests; one at the extreme temperature and, after the soak cycle, one at room temperature.

Each component was first low temperature cycled at all three levels, high temperature cycled at all three levels, vibrated, shocked, and accelerated, in that order, at the three consecutive levels. The final test was a test-to-failure vibration. This last test was omitted for Test Plan B as well as acceleration testing.

The vibration test consisted of a 6-minute vibrational sweep from 20 to 2000 to 20 cps, except as g limited. The sweep was to locate resonances in all three major planes. The sensors were to be operating during the vibration and tested afterward to locate any vibrational damages. After the initial third level test, the g level was increased in 4 g increments and the frequency cycled until component failure.

The shock test was to be applied in both directions of all three axes for 12 milliseconds if triangular waveform was used, for 10 milliseconds if sinusoidal waveform was used, and 8 milliseconds if square waveform was used. The acceleration test consisted of a 5-minute acceleration in both directions of all three axes with simultaneous longitudinal and lateral acceleration along, and perpendicular to, the direction of test. After the shock and acceleration tests, functional checkouts were scheduled. No shock or acceleration test-to-failure tests were planned.

5.3.4 RELIABILITY STUDIES

After flight MR-2 the reliability of the MERCURY-REDSTONE was re-examined in regard to its suitability for manned flight (reference paragraph 8.3). Three separate studies were made. The first was based on the running average of flight success probabilities which would place the payload at the proper injection point. The second study was based on an artificial configuration using the flight record of all components, weighting their failures according to the number of flights made by each component. The third study will be defined later. The results of the running average investigation were as shown in Table 5-6. The results of the component evaluation were as shown in Table 5-7. The probability of booster success thus was estimated, as shown in the tables, to be between 78 percent and 84 percent at a 75 percent confidence level.

Table 5-6

MERCURY-REDSTONE Reliability Prediction (10 February 1961)* -A

Probability Of	Straight Average	Running Average	
		50 Percent Confidence	95 Percent Confidence
Booster Success	81.2	80.3	77.4
Crew Escape	98.6	97.6	94.3
* Basis: All REDSTONE, JUPITER-C, and MERCURY-REDSTONE Booster Flights (69 Flights).			

Table 5-7

MERCURY-REDSTONE Reliability Prediction (10 February 1961)* -B

Subsystem	Number of F rings of Components Composing MR Subsystem	Probability of Booster Success 75 Percent Confidence as Based on	
		Past Firings	Engineering Estimates **
Propulsion	10 to 67	90 Percent	94 Percent
Structure	10	96 Percent	96 Percent
Control	27 to 67	94 Percent	96 Percent
Pressurization	67	96 Percent	99 Percent
Human Error	67	96 Percent	98 Percent
Total	10 to 67	78 Percent	84 Percent
* Basis: MERCURY-REDSTONE Configuration as Composed of Subsystem Components			
** Based on Component Improvements Achieved with Corrective Action.			

Many components were originally designed to mission parameters exceeding those required for the MERCURY-REDSTONE mission. In addition, the launch operations personnel had developed techniques more conducive to satisfactory flight. These facts, coupled with the improvements incorporated on the vehicle with the low probability of inadvertent abort, led MSFC to the opinion that the MERCURY-REDSTONE launch vehi-

cle reliability was in the range of 88 percent to 98 percent probability for launch success and crew survival, respectively. The successful MR-BD flight gave the assurance that the MERCURY-REDSTONE was ready for manned flights.

As stated previously, a portion of these studies was an evaluation of all components comprising the launch vehicle. Most of these components or their prototypes had flown in earlier REDSTONE and JUPITER-C vehicles. The rating of the components and their allied systems necessarily considered not only the number of times flown but also any malfunctions which were known to have occurred and whether this type of malfunction had been completely eliminated for future flights. Thus, a third and more refined reliability study was made.

For the third calculation, the effect of each malfunction was carefully adjusted in value based on its possible contribution to a vehicle failure that could occur and adversely affect a MERCURY-REDSTONE mission. Particularly sensitive to such judgment was the impact of human errors. Both human errors and component malfunctions which had occurred during a recent firing were given more weight than the earlier occurrences. Consideration was also given to system design improvements, incorporated during the period of system use, and repetitive performance improvement or learning curve in both personnel performance and improved operational techniques. The malfunction and failure data thus derived was then examined for the possibility of occurrence in the MERCURY-REDSTONE vehicle, as fabricated and checked out under its more stringent standards of construction and quality assurance.

This component and system evaluation resulted in synthetic data which were deemed as representing reasonable expected failure or malfunction rates in the MERCURY-REDSTONE launch vehicle. Reduction of these data to a common confidence level was based on the assumption that the calculated reliability was the mean of all reliabilities represented by a series of samples of like size. A further interpretation of this implies that the calculated reliability represented the mean of the actual reliabilities of the individual flights. In addition, it was assumed that this hypothetical series of reliabilities followed a Gaussian or normal distribution. This derivation of an estimated standard deviation then permitted the determination of system reliability for various confidence factors.

The reliability estimates thus derived were presented in terms of confidence factors in which the level of confidence was interpreted to mean that the reliability estimated would be as stated or higher in the percentage of cases represented by the confidence level. Typical of such data derived at this point in the program was:

Vehicle Reliability
(Successful powered flight without abort)

84 Percent
75 Percent

Confidence Level

50 Percent
75 Percent

An alternate method of data presentation to more readily permit a judgment of the spread in data is shown below. Here, the confidence interval expresses the percentage of cases which will lie within the expected or calculated reliability range.

Confidence Interval

50 Percent
75 Percent

Reliability Range

75 to 94 Percent
69 to 98 Percent

This portion of the study thus attempted to derive a reliability and confidence factor by comparing the MERCURY-REDSTONE vehicle components to previous flight history, allowing for differing systems operation, design modifications and improvements, changing procedures, and different missions. The data on which the above values are based are given in Table 5-8.

Table 5-8
Evaluation of Flight Data on MERCURY-REDSTONE Components

	No. Flights	Observed Malfunctions	Weighted Failures*	Anticipated Failures**
<u>Flight Control</u>				
LEV-3	27	4	1	0.75
Network and Actuators	67	6	2	1
<u>Structure</u>				
LOX manhole cover	10	10	0.25	0.25
Elongated tanks	10	0	0	0
<u>Propulsion</u>				
H ₂ O ₂ regulators	67	3	2	1.5
A-7 engine	10	4	0	0
Thrust controller	42	5	5	0.4
H ₂ O ₂ lead start	45	0	0	0

Table 5-8

Evaluation of Flight Data on MERCURY-REDSTONE Components (Cont.)

	No. Flights	Observed Malfunctions	Weighted Failures*	Anticipated Failures**
<u>Pressurization</u>				
Propellant and Turbine	67	4	0.25	0.20
Instrument Compartment	67	1	0	0
<u>Human Errors</u>				
Personal	67	5	2	1
<p>* Weighted failures are those observed malfunctions which would cause (by engineering judgment) an unacceptable M-R booster flight.</p> <p>** Anticipated failures are weighted failures that might not be eliminated on M-R boosters in spite of present corrective action.</p>				

5.4 QUALITY ASSURANCE AND MERCURY AWARENESS PROGRAM

5.4.1 GENERAL

The MERCURY-REDSTONE quality assurance program placed primary emphasis on eliminating the human errors in fabrication, assembly, inspection, and test. This was accomplished in a threefold effort that effectively used careful documentation, hardware, checkout, and personnel motivation.

5.4.2 MERCURY AWARENESS PROGRAM

The Mercury Awareness Program, dealt with the personnel motivation or the human aspect of quality. It inspired all individuals to do their best. MERCURY stamps were issued to trained people to use with discretion on approved documentation and hardware (Figure 5-16). Publicity and awards focused attention on the good work of conscientious people. This program was a keystone of quality and has since been repeated in every manned space program.

The importance of the MERCURY stamps should be noted. Since the REDSTONE was built as a military weapon system the MERCURY stamps identified the hardware which would carry a man into space. In addition to identification of MERCURY flight components the stamps promoted a psychological awareness of the ultimate use within each handler of the part. By 7 October 1959, use of these stamps established that only MERCURY-identified documentation and hardware were utilized throughout the MERCURY program. The stamps further identified preliminary and final status by circular and square

enclosures, respectively. Use of any spare parts or documentation not identified by the square stamp was prohibited. This identification procedure further assured that the 100 percent inspection directive for Project MERCURY was carried out.

5.4.3 DOCUMENTATION

The quantity of development documentation was increased only slightly over that of the tactical REDSTONE. Emphasis was placed on complete and accurate records rather than on additional forms. Standard REDSTONE instructions and specifications were used except where specific MERCURY documentation was required. Test procedures were reviewed and new mechanical and electronic procedure specifications prepared. Running time reports were kept on all parts, and functional and inspection test reports were required to be complete in all details.

5.4.4 QUALITY ASSURANCE TESTING

The improved documentation and procedures, assured proper testing and correct selection of components. Since parts for the MERCURY-REDSTONE Program were being fabricated and processed coincidentally with those for the tactical REDSTONE missile, the components whose characteristics were closest to the nominal were selected for the MERCURY Program; all others were assigned to the tactical REDSTONE missile. Once selected for Project MERCURY, all parts were identified with a MERCURY stamp.

Receiving inspection included each component. During systems buildup, inprocess inspections monitored quality of the combined units. Tests included magnaflux and radiographic inspection of engine parts, inspection of electrical soldering and cable construction, and acceptance tests which simulated conditions of application.

After assembly a booster checkout was conducted. Since all components and subsystems had been inspected, functionally tested, and installed, the final checkout was used to determine that they would work as a single vehicle system. In this checkout, power was applied and each system checked out separately. Then compatibility tests were run to insure that no deteriorations had occurred as a result of the intercoupling.

The final factory test was the simulated flight test. The ground equipment system was connected using actual launch equipment where feasible and simulated where flight equipment could not be operated. The test began with a launch countdown and the

equipment was operated sequentially in the same order as it would on an actual flight. Telemetry recordings were made through an RF link. At the completion of the test, the records were examined for proper equipment operation. If the records were good, the vehicle was acceptable for launch use.

Special procedures were also established for the testing and selection of spare parts for each booster. All spare assemblies and subassemblies, assigned to a specific vehicle, were checked for compatibility at MSFC during checkout tests. These parts were then identified by missile number and, if not used at the launch site, were returned for checkout with a subsequent reassignment.



Figure 5-16. MERCURY-REDSTONE Manned Flight Awareness Stamp

SECTION 6

DEVELOPMENT TEST PROGRAM

6.1 INTRODUCTION

The MERCURY-REDSTONE development program included the normal ground test required in all launch vehicle programs plus those added due to the manned payload. Thus, in addition to a description of the mechanical and electrical checkout testing, this section includes details of special reliability and vibration dampening programs. The booster recovery program is also covered as it was the first such program to reach the test phase. The flight development tests are detailed in Section 8.

6.2 VEHICLE TEST PROGRAM

6.2.1 GENERAL

The MERCURY-REDSTONE test program retained the high quality test procedures used for component selection and booster assembly. Only after the vehicle neared full system status were special systems tests necessary. The final systems tests to which the launch vehicle was subjected were the following:

- Mechanical assembly analysis.
- Static firing.
- Alignment (mechanical).
- Pressure and mechanical function.
- Continuity (electrical).
- Network (includes over-all No. 1).
- Radio frequency systems.
- Guidance and control system.
- Over-all test No. 2.
- Instrument calibration.
- Over-all test No. 3.
- Simulated flight test (electrical).
- Final pressure and functional analysis.

The testing sequence was based on the pyramidal testing philosophy, whereby components, subsystems, and finally the entire vehicle was functionally checked. This type of testing, illustrated in Figure 6-1, verified proper operation of all hardware within the vehicle.

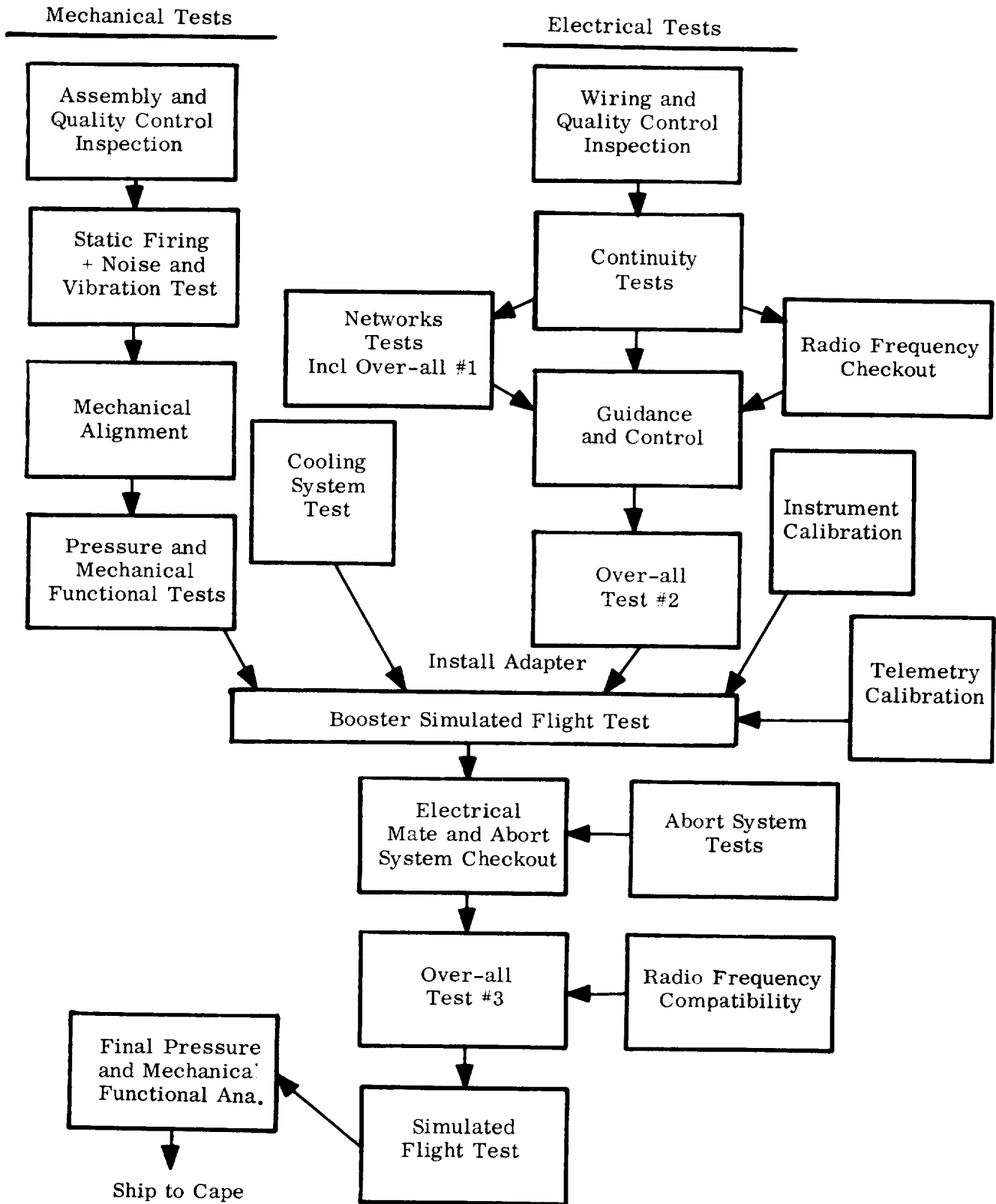

Figure 6-1. MERCURY-REDSTONE System Test Flow Diagram

Within this section, reference to boosters will be made based on their assembly number, not their ultimate flight number; e.g., booster MR-8, which served as the launch vehicle for Flight MR-4, shall be referred to as MR-8. This notation on the use of nomenclature is necessary due to the similarity of the numbering systems. A cross tabulation of booster and flight numbers is as follows:

<u>Booster No.</u>	<u>Flight No.</u>
MR-1	MR-1
MR-2	MR-2 ("Ham")
MR-3	MR-1A
MR-5	MR-BD
MR-7	MR-3 (Shepard)
MR-8	MR-4 (Grissom)
MR-4	Not Launched
MR-6	Not Launched

6.2.2 MECHANICAL ASSEMBLY ANALYSIS

Although assembly analyses were performed throughout buildup, a final mechanical analysis was performed on each vehicle prior to assembly release. Difficulties encountered during the analysis resulted in either replacement of faulty components or rework. All deviations from specified documentation were documented by a Waiver Approval Request. A standard modification was made on Boosters MR-3, -5, -7, and -8. On these vehicles the LOX tank manhole cover, gasket, and LOX tank bulkhead flange were modified by increasing the bolt hole diameters to 0.390 ± 0.005 inch, replacing the 5/16 inch steel bolts with 3/8 aluminum bolts and torquing these bolts to 175 ± 5 inch-pound. In the event it was necessary to disassemble the manhole cover, replacement of the 3/8 inch aluminum bolts was required due to the high torque value used.

6.2.3 STATIC FIRING

6.2.3.1 Introduction

As part of the prelaunch procedures and checkouts, each of the eight MERCURY-REDSTONE launch vehicles was scheduled for static firing tests to insure satisfactory performance and reliability under rated thrust conditions. These tests were conducted on the interim test stand at the Marshall Space Flight Center (MSFC). A total of 32 static tests were conducted on the MERCURY and test boosters with an accumulated

time of over 2230 seconds. In addition to the basic static firing tests to assure proper assembly and operation of the propulsion unit, additional tests were run to derive both additional data and help solve specific problems.

6.2.3.2 Capsule Noise and Vibration Tests

Noise and vibration effects on the missile and capsule were evaluated early in the program in a series of four test firings in the static test tower using a boilerplate capsule. The results, shown in Table 6-1, indicate these environment conditions were not detrimental to the booster or capsule.

Table 6-1
Sound and Vibration During Static Firing

Location	Sound Pressure Level at 1000 cps (db)	Composite Vibration at Mainstage Thrust - peak g		
		Lateral	Longitudinal	Pitch
Tail Fin	141			
Outside Capsule	123			
Inside Capsule	101			
Escape Rocket	123	2	1	2
Capsule Adapter			4	4.3
Instrument Comp. (TV Camera)			1.5	
Fuel Tank		4.5	4.5	
Thrust Frame		4.5	6.5	8.2

6.2.3.3 Hydrogen Peroxide System

Subsequent to the static firings of MR-1 and MR-2, a major redesign of the H₂O₂ system was effected. The redesign required O-ring seals in lieu of metal-to-metal seals in the system. The results of the tests conducted during the static firing of MR-3 indicated the O-rings to be functioning properly and, therefore, satisfactory for flight. The O-rings also appeared to be compatible with the heat produced by H₂O₂ system heater blankets, which were also part of the modifications.

6.2.3.4 Oscillation Problems

When MR-4 was static fired the first time, an unexpected low frequency oscillation (approximately 10 cps) was discovered in the oscillograph traces of the engine parameters. This oscillation had not been present during the static firings of the previous boosters. A thorough investigation revealed that the oscillations were the result of resonance of the test stand with the second bending mode of the booster when the booster was mounted from the top of the stand. The modification to the stand, subsequent to the MR-1 and MR-2 tests but prior to the MR-3 test, had changed the resonant frequency of the stand. MR-3 did not resonate because it was attached in a different manner. Modification to the stand prevented this resonance.

6.2.3.5 Boattail Heater Tests

In tests simulating the actual launch countdown, LOX was loaded several hours prior to ignition. To maintain all engine parameters and critical temperatures within specified limits during the hold period, hot-air-type heater ducts were inserted through the access doors into the boattail section. During the series static firings, hold periods as long as eight hours were successfully made without adverse affects.

6.2.3.6 LOX Manhole Cover Seal Leaks

When several LOX leaks occurred in the LOX tank manhole cover seal of various REDSTONE vehicles, a test program was initiated to determine the cause and characteristics of the leaks. Compression of the cover gasket was approximately 0.012 inch greater using lubricated bolts than when nonlubricated bolts and washers were used at the same torque values. However, complete sealing was not achieved in any test, even with the cover bolt tightened to 190 inch-pound torque using no lubricant.

6.2.3.7 LOX Replenishing Tests

In a further effort to simulate actual launch conditions, the LOX replenish system was tested to determine its capability to maintain the required LOX level during extended hold periods. No difficulties were experienced with the system.

6.2.3.8 Abort Sensors

A problem was encountered in the early phase of testing when water (used in the inert start) was blown into the two abort combustion chamber pressure (P_c) sensing lines and the single thrust controller transducer P_c line. The low LOX temperatures then

froze the water preventing proper operation of the sensors. This difficulty was solved by the utilization of strip heaters on all three lines.

6.2.4 ALIGNMENT TEST (MECHANICAL)

After static firing and before the integrated mechanical-electrical checkout tests, mechanical alignment checks were performed on the power unit, the tail section, the aft unit, and, finally, on the entire thrust unit. All six boosters successfully completed their alignment tests; however, four problem areas occurred during this checkout. The test plan included a capsule adapter mating alignment check. Since none of the adapters were available at the time of the alignment tests, only the mating surfaces were checked. Difficulty in assembly of the jet vane plates caused the plates on MR-1 and MR-3 to be off in perpendicularity. On MR-2 and -8 the plates were off in angularity. These discrepancies were minor and were waived. The first three vehicles required shimming of the engine. MR-1 and -2 were shimmed because the mounting holes would have otherwise been too close to the edge of the mounting ring. MR-3 was shimmed and MR-1 additionally shimmed to correct for thrust vector misalignment.

6.2.5 PRESSURE AND FUNCTIONAL ANALYSIS

Pressure and functional analysis tests were performed to assure correct operation of the pneumatic and hydraulic systems of the vehicle. All systems on all vehicles were within limits. Actually, two sets of pressure and functional tests were made; the first immediately after the alignment tests and the final before booster shipment to the launch site. Vehicles MR-3, -5, -7, and -8 were shipped with 10 psig air pressure in the gaseous nitrogen spheres.

6.2.6 CONTINUITY TESTS (ELECTRICAL)

Electrical assembly and installation and ground support equipment compatibility were checked. All vehicle connectors and cables were inspected, and resistance measurements were made on all wire to assure that continuity existed. In addition, all vehicle distributors and the ground support equipment were verified prior to connecting to the vehicle. Several installation discrepancies were revealed in MR-2, -3, -5, -7, and -8, all of which were corrected prior to release of the vehicle. After correction of these discrepancies, the test results were satisfactory.

6.2.7 NETWORK TESTS

6.2.7.1 Introduction

This group of tests performed on the vehicle were given the general classification of network tests and consisted of the component test, cutoff test, and over-all Test No. 1. It was in this group of tests that the electrical location of relay contacts, diodes, and solenoids were ascertained from comparison with the vehicle schematics.

6.2.7.2 Component Tests (Propulsion System Electrical Network)

The component tests were designed to verify proper operation of components associated with the propulsion system operation. This test was performed in two parts. The first part, performed without pneumatic pressure, verified the electrical location and operation of propulsion-control relays and valve solenoids. For safety reasons, special attention was given to the control circuits for pressurizing and venting the high pressure pneumatic spheres. The second part, performed with pressure applied to the spheres, checked the operation of pneumatic valves and valve position switches. The component tests verified that all components associated with the propulsion engine operation were satisfactory on all six vehicles.

6.2.7.3 Cutoff Test (Shutdown and Abort System Networks)

The cutoff test was not limited to verification of the vehicle cutoff circuitry as the name implies, but actually entailed extensive testing of the abort circuits, destruct command receivers, and flight sequencer operation. In addition, the television on-off command and the circuitry for shifting the television lens cover were verified up to the point of entry into the television junction box and camera assembly. The cutoff tests on MR-1, -7, and -8 were completed satisfactorily. While verifying proper operation of the MR-3's electrical network, two diodes and a relay were found to be faulty. In addition, two shorting pins in a ground equipment connector were causing the inverter to malfunction. Replacement of the faulty parts eliminated these problems. Vehicle MR-5 had satisfactory results; however, during the test it was necessary to replace a relay in the GSE test conductors panel, as a result of the failure of one of its contacts.

6.2.7.4 Over-all Test No. 1 (Sequential Flight Simulation)

An over-all test is defined as a test in which, as a minimum, a switch-on sequence is performed, followed by a transfer from ground to vehicle internal power, a rocket engine firing sequence, a simulation of liftoff, and a rocket engine cutoff signal is

given. Over-all test No. 1, the third network test, was designed to test the sequential operation of the valves, relays, and solenoids involved in the engine firing; also tested were the program device, flight sequencer, and physical separation of the top and tail umbilicals.

During the over-all test No. 1 on MR-1 and MR-2, trouble was encountered with the preflight cooling system operation and circuitry, which was corrected by replacement of components and rewiring. As a result, later LN₂ external cooling systems were required to pass a checkout simulation prior to the over-all test. A false abort was indicated during MR-2's over-all test. The exact initiator of the abort could not be identified, but the rate switch circuitry was suspected. A redesign of this circuit was made to eliminate any possible cause. The program device was found to be faulty on MR-3. MR-5, -7, and -8 passed over-all test No. 1 satisfactorily.

6.2.8 RADIO FREQUENCY SYSTEMS CHECKOUT

These tests were performed to insure that each RF component operated properly within specified limits during individual functional checks. In addition, the tests verified that the RF components were compositely compatible with themselves and with the general network. Interference was encountered when MR-2 and MR-5's television circuits were in a standby mode. However, during normal operation the television oscillator frequency radiation dropped to a noninterference level.

6.2.9 CONTROL SYSTEMS CHECKOUT

The control system checkout was performed to ascertain the function of the system as it related to the vehicle performance requirements. Controlled inputs were introduced into the system, and the outputs were accurately checked for proper polarity and scale factors. MR-1, -2, -3, and -5 tested satisfactorily. Replacement of faulty attitude error sensor was necessary on MR-7. Dust in the pitch attitude sensor of MR-8 required cleaning of the sensor before final acceptance.

6.2.10 OVER-ALL TEST NO. 2

This test was performed to assure proper functioning of the vehicle's control system integrated into the general network. The test sequence was similar to that of over-all test No. 1 but with the addition of the control system. The results of over-all test No. 2 were completely satisfactory for all vehicles.

6.2.11 INSTRUMENTATION CALIBRATION

Signal outputs from the various measuring transducers were first checked to calibration curves via hardwire link; then, the information was connected to the telemetry package and rechecked via RF link. The results of the instrumentation and calibration tests on MR-1 and MR-2 were completed satisfactorily. The remaining vehicles had several minor problems none of which indicated a specific problem area.

6.2.12 OVER-ALL TEST NO. 3

In this test the control, RF, and instrumentation subsystems were integrated and tested as a complete system. The test consisted of a brief subsystem operational check and then a complete simulated firing and flight sequence. The vehicle was put in a ready-to-fire condition, firing command was given, and the sequence of events that followed was automatic until liftoff. Liftoff was simulated by de-energizing the tail plug supervision relays in the ground equipment and the liftoff relays in the vehicle. This method of simulating liftoff allowed continuous monitoring and recording of vehicle operation during the simulated flight period. After liftoff, the program device controlled the operation of the flight sequencer, the telemeter calibrator, and the tilt program of the LEV-3. The vehicle was then given a normal cutoff from the velocity integrator, and, shortly thereafter, the test was completed by simultaneously removing all power from the vehicle and ground equipment. Vehicles MR-1, -2, -3, and -5 completed the tests with satisfactory results. MR-7 encountered a broken lamp contact in the ground propulsion panel. Additional shield grounding was required to eliminate erratic pulses on MR-8's program device channel No. 1.

6.2.13 SIMULATED FLIGHT TESTS

This final test of the booster was designed to prove the compatibility of all electrical and electro-mechanical systems (vehicle and ground equipment) in simultaneous operation. Safety-relay boards were installed in the main, tail, and power distributors to make this test more realistic. The test was performed using a simulated countdown procedure. Preliminary checks were made in which the vehicle subsystems were energized and operationally verified. The vehicle was then placed in a ready-to-fire condition, and the firing command was given. The vehicle underwent a typical flight program, controlled by the program device, with small deviations from the normal trajectory simulated by the tilt program of the LEV-3. At liftoff plus 140 seconds, cutoff was given by the velocity integrator, and 30 seconds later the test was terminated by simultaneously removing power from the vehicle and the ground equipment.

Since the vehicle's instrumentation was active during the test, its telemetered information was utilized for evaluation.

MR-1 and -3 passed successfully. MR-2 had problems with foreign material causing shorts in the commutated telemeter channels. MR-5 had flight sequencer problems which were solved by redesign and removal of two zener diodes. The roll rate gyro was also defective and was replaced, as was the thrust controller transducer. MR-7 was rerun twice before the proper procedures were used and MR-7 passed. The pitch attitude potentiometer had to be cleaned and the pitch rate switch replaced before MR-8 passed its simulated flight test.

6.2.14 RETEST AFTER MODIFICATION

After the test program had progressed through the simulated flight test, a number of changes to assure the best possible boosters were incorporated. After making these changes, the systems affected were rechecked to verify proper operation. The most extensive modifications were made on MR-5; thus, the MR-5 checks consisted of a continuity test of new and modified cables, a series of network tests which verified proper operation of the vehicle's electrical circuitry, measuring and control systems check, and an operation verification of the RF equipment. An over-all test was then performed to verify proper operation of the network, control, RF, and measuring system. In-flight measurements were telemetered to verify calibration of the measuring system. Proper operation was obtained during these tests.

6.2.15 BOOSTER-CAPSULE COMPATIBILITY TESTS

The original test plan included mating each capsule plus its GSE to the booster and its GSE at MSFC for a final compatibility test prior to shipment to the launch site. The compatibility tests were to include electrical continuity, RF, separation, abort system, and an over-all test. On MR-1 several compatibility problems (noted below) were encountered; however, MR-2 tests experienced no new compatibility difficulties. Therefore, for vehicles MR-3 through MR-8 only the capsule adaptors were mated and tested.

Compatibility measurements on the Booster MR-1 and its GSE indicated that the MAYDAY circuit from the vehicle GSE to the capsule would allow a high current flow and could possibly prevent completion of the abort sequence. To assure launch director abort capability, a diode was added to the capsule circuitry. During the final RF checkout on MR-1 and -2, the booster's DOVAP signal interfered with the capsule's

two command receiver signals. A change in command frequency and removal of the booster DOVAP eliminated this interference. Also during the mating, the clamp ring retention devices were found to be incorrectly designed and were redesigned by MSFC. Lastly, electrical connectors and wire bundles from the booster to the adapter could not be properly installed. Relocation of the connectors and removal of the recovery system package solved these interface problems.

6.3 SPECIAL RELIABILITY TESTS

6.3.1 GENERAL

In addition to the developmental tests, several special reliability test programs were conducted to attain the degree of assurance required by the manned payload. These tests were conducted as a portion of the over-all reliability, quality control, and check-out program.

6.3.2 THRUST UNIT STRUCTURE

Structural testing of the thrust unit was done in three separate tests:

- Simulated flight loads were imposed on the vehicle to 150 percent of the nominal value on the tail and center sections to determine the margin of safety. Combined axial compression, shear, and bending loads (Figure 6-2) were applied without resulting damage. In addition, the propellant tanks were pressurized until they burst. The tests were conducted in a vertical test tower.
- Fin and rudder test determined the tail unit's capability to withstand flight and handling loads exceeding 150 percent of the design values.
- Ground handling tests determined that there were no detrimental effects when bending, shear, and axial compression loads, equaling 150 percent of design values, were applied to the forward and aft handling fixtures.

6.3.3 AFT SECTION

An aft section, MRF1, containing the guidance and control system, the abort system, telemetry, and the instrument compartment cooling system was subjected to temperature and vibrational environments in a special test setup known as the "rock and roll" stand, Figure 6-3. Testing was divided into three phases.

- Phase I - Flight motions and vibrations were imposed at ambient temperatures in seven cycles, Figure 6-4. Outputs of the systems under test

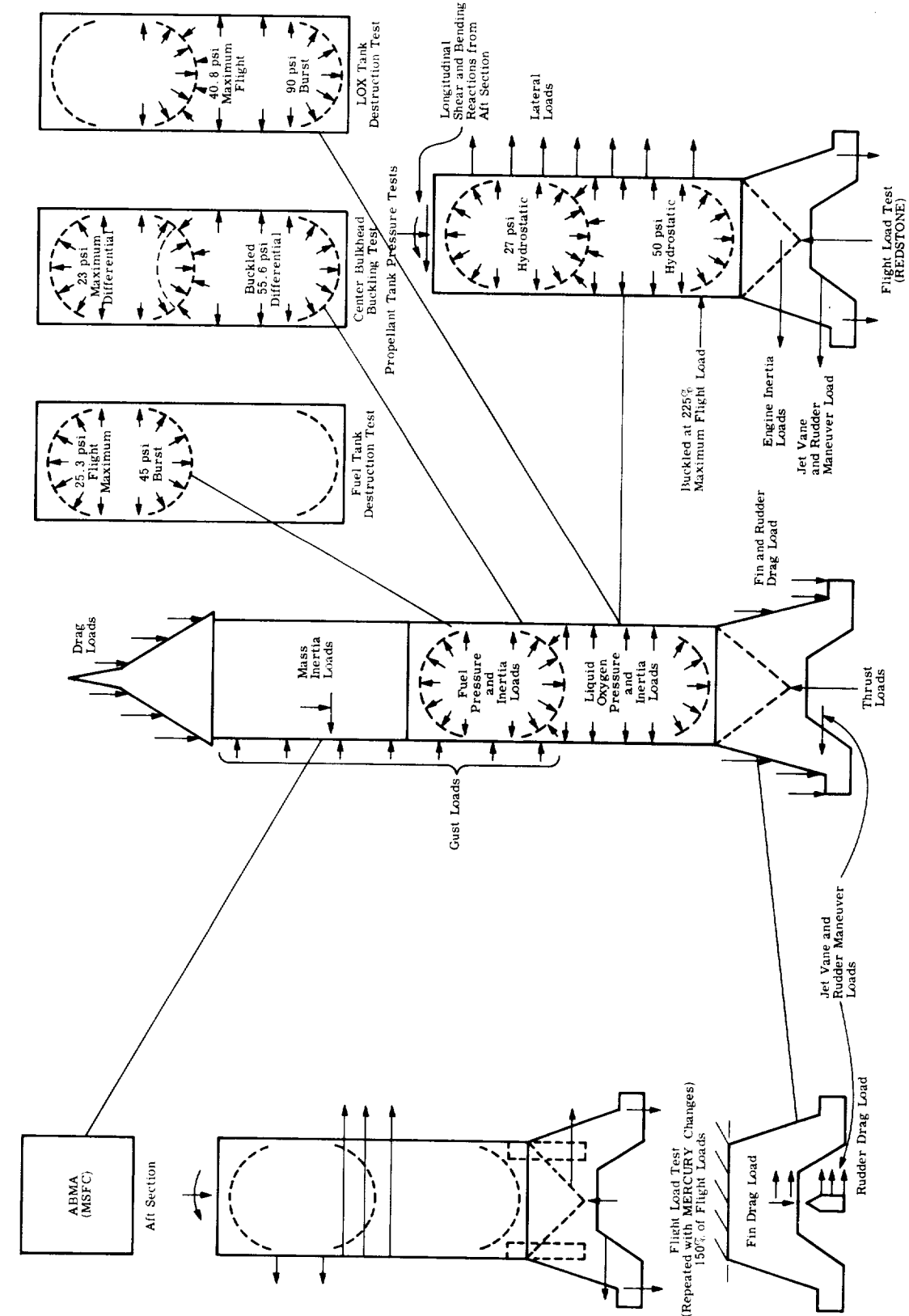

Figure 6-2. Flight Environment of Thrust Unit

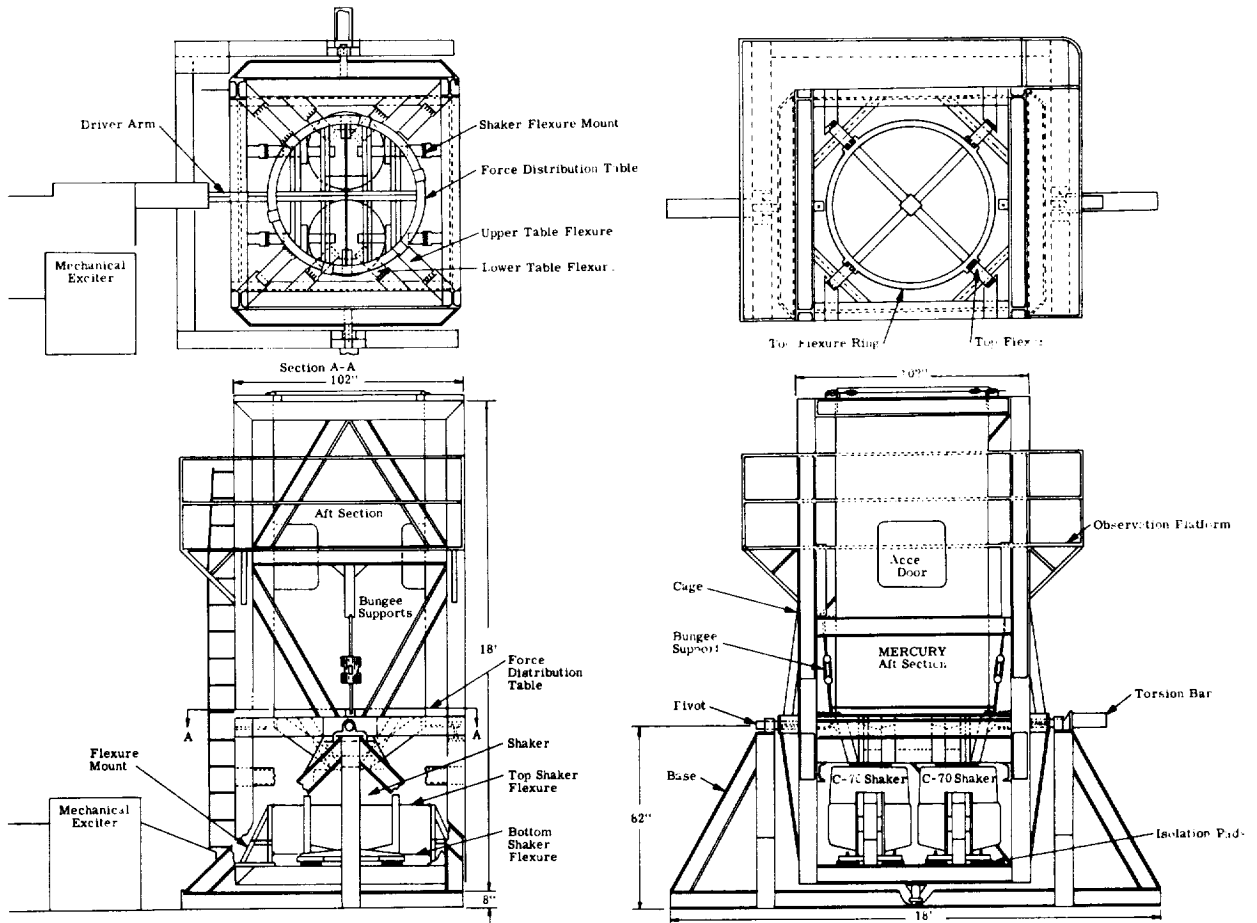

Figure 6-3. Vertical Test Fixtures

	CYCLE I	CYCLE II	CYCLE III	CYCLE IV	CYCLE V	CYCLE VI	CYCLE VII
<p>Phase I</p> <p>Flight Vibration and Motion</p> <p>Object: To Subject A REDSTONE MERCURY Aft Section To The Vibration Most Likely Encountered During Flight</p>	<p>1 g</p> <p>20-2000 cps</p> <p>Sweep Time</p> <p>50 Sec & 20 Sec</p> <p>Ambient Temp</p>	<p>1 g</p> <p>20-2000 cps</p> <p>Sweep Time</p> <p>50 Sec & 20 Sec</p> <p>Ambient Temp</p>	<p>1 g</p> <p>20-2000 cps</p> <p>Sweep Time</p> <p>50 Sec & 20 Sec</p> <p>Ambient Temp</p>	<p>1 g</p> <p>20-2000 cps</p> <p>Sweep Time</p> <p>50 Sec & 20 Sec</p> <p>Ambient Temp</p>	<p>1 g</p> <p>20-2000 cps</p> <p>Sweep Time</p> <p>50 Sec & 20 Sec</p> <p>Ambient Temp</p>	<p>1 g</p> <p>20-2000 cps</p> <p>Sweep Time</p> <p>50 Sec & 20 Sec</p> <p>Ambient Temp</p>	<p>1-2-3-4 g</p> <p>20-2000 cps</p> <p>Sweep Time</p> <p>3 Minutes</p> <p>Ambient Temp</p>
<p>Phase II</p> <p>Instrument Compartment Cooling</p> <p>Object: To Determine The Capability of the External Cooler To Cool and Dry The Instrument Compartment. The Effect Of This On The Inverter Brushes Will Also Be Determined.</p>	<p>Temperature</p> <p>70-75 ° F</p> <p>Relative Humidity</p> <p>85 to 90 %</p>	<p>Temperature</p> <p>85-90° F</p> <p>Relative Humidity</p> <p>85 to 90 %</p>	<p>Temperature</p> <p>110-115° F</p> <p>Relative Humidity</p> <p>70 to 75 %</p>	<p>Temperature</p> <p>110-115° F</p> <p>Relative Humidity</p> <p>70 to 75%</p>			
<p>Phase III</p> <p>Transportation And Pad Temperatures</p> <p>Object: To Determine If The Temperatures Encountered During Transportation And Stand-By On The Pad Will Effect The Systems Operation.</p>	<p>TEMP</p> <p>0° F and 125° F</p>	<p>TEMP</p> <p>0° F and 125° F</p>	<p>TEMP</p> <p>0° F and 125° F</p>				

Figure 6-4. Aft Section Test Summary

were continuously recorded and indicated intermittent operation of the pitch program and the pitch and yaw rate switches. During the seventh cycle when the loads exceeded design values, the telemetry commutator intermittently failed, and a command receiver pitch rate switch and one computer output channel failed. All malfunctions were corrected prior to flight qualification. A subphase test, the abort systems test, determined that the proper abort signals were given when the abort pitch and yaw rate switches were oscillated (rocked) and the voltage to the control voltage sensor was stepped below the abort limit.

- Phase II and III - Instrument compartment cooling and transportation and pad temperature tests (Figure 6-4) were completed without discrepancies.

6.3.4 PROPULSION SYSTEM

The propulsion system's fill and vent valves, suction lines, and rocket engine were simultaneously vibration and temperature tested in a combined environment chamber. The temperatures ranged between -10°F and 125°F (the LOX system was tested at LN_2 temperatures). Imposed vibrations up to 20 g's were swept between 20 and 2000 cps. Table 6-2 lists the results of this test.

6.3.5 TAIL SECTION

A MERCURY-REDSTONE tail section, RMF73, containing all mechanical and pneumatic systems were vibration and temperature tested under similar conditions imposed on the propulsion system. The results of this test are given in Table 6-3.

6.3.6 CAPSULE-BOOSTER COMPATIBILITY

A 36-day checkout of the physical and functional compatibility of the capsule and booster was made on MR-1 and MR-2 at MSFC. This checkout was part of the development tests described in paragraph 6.2. For vehicles MR-3 through -8, the capsule compatibility was checked at the launch site and only the flight adapter-booster compatibility checked at MSFC. These over-all checkouts were of great value in achieving the reliability demonstrated by the MERCURY-REDSTONE.

6.3.7 ABORT SYSTEM

An abort system test program was conducted to assure the proper and reliable functioning of the automatic abort system. The tests and their results are detailed in paragraph 5.4.

Table 6-2
Propulsion System Test Results

Component	Failure Level	Failure	Corrective Action
Engine:			
Regulator	125° F 1g	Pressure Varies	All Regulators Flow Tested
Fuel Duct Support	125° F 3g	Weld Cracked	100 Percent Inspection
Main Fuel Valve	125° F 5g	Main Shaft	Failure Attributed to Procedure
Tube Clamp H ₂ O ₂ Line	2g Resonance	Clamp Failed	Additional Clamp Added
H ₂ O ₂ Tank Bracket	2g Resonance	Weld Failure	Leakage Slight After Test Complete - No Action
Steam Generator	0° F 5g	Weld Failed	Additional Support Added
Auxiliary H ₂ O ₂ Tank	125° F 3g	Support Failed	Modified Design for Additional Support
Steam Exhaust Duct	2g Resonance	Deformed	No Rupture - No Action Required
Thrust Control Amplifier	2g Resonance	Lock Nuts Loose	Inspect Locknuts - No Design Action
LOX Fill System	12g	Valve Leakage	Acceptable
LOX Vent System	12g	Valves Failed	Modification not Warranted
Fuel Vent System		Weld Failed	Added Support on Pressure Line

Table 6-3

Tail Section Test Results

Item	Failures	Remarks
Triple Sphere Support Bracket	Major Failure of Support Bracket	Redesign bracket tested during second phase of test with only minor failure - larger rivets used in final design.
Single Sphere	Abrasion of Support Bracket	Pad incorporated in design
	Cracks in Support Structure	Not considered a major discrepancy
Pneumatic System	None	Design Acceptable

6.4 MASS DAMPENING OF INFLIGHT VIBRATIONS

6.4.1 GENERAL

After the second successful flight, MR-2, a program was initiated to reduce the vibrational environment of the instrument compartment where vibration sensitive components were located. Since the major sources of excitation in this area were the acoustic environment at launch and the aerodynamic turbulence during flight, due to the change in the diameter of the spacecraft relative to that of the booster, the primary approach was to reduce the energy absorbed by the structure by mass dampening of the panels that were subjected to the excitation environment.

6.4.2 METHOD OF MASS-DAMPENING

The first step in an effort to reduce the vibrational environment was a program to develop a viscoelastic material of high specific gravity which would be easily applied. A mass dampening compound, X306, was developed by the Materials Branch at MSFC. The material was a mixture of lead chips (60 to 70 percent by volume) in epoxy polysulfide. Figure 4-24 illustrates the vehicle areas to which the compound was applied.

On MR-BD, 170 pounds of the material were applied to the inner sides of the skin panels in the bays of the recovery compartment and 40 pounds were applied to the

upper bulkhead of the instrumentation compartment proper. This made a total of 210 pounds applied to MR-BD.

In MR-3, the material was not only applied to the above areas but also 120 pounds were applied to all the access doors of the instrumentation compartment making a total of 330 pounds applied to MR-3.

The material was applied to the doors, the lower bulkhead, and all the accessible panels of the instrumentation compartment of MR-4 as well as the recovery compartment for a total of 405 pounds. The total amount of mass dampening material applied to the instrumentation compartment proper of MR-4 was 235 pounds. The application of the mass dampening material to this latter area had the most significant effect on the vibrational environment, and it is felt that the 235 pounds applied to the instrumentation compartment would have been sufficient.

6.4.3 VIBRATIONAL MEASUREMENTS

6.4.3.1 Introduction

On each flight at least two vibration transducers were installed in the aft unit of the vehicle to measure the vibrational environment during powered flight. Measurement 901 was mounted on the adapter ring and was oriented to measure vibration in a direction perpendicular to the longitudinal axis of the vehicle. This measurement was made on every flight. Measurement 903 was located on the rate gyro mounting bracket and was oriented to measure vibration in the longitudinal direction of the vehicle. When the MR-1A vehicle overshot the target area, measurement 903 was moved to a new location on the LEV-3 velocity cutoff platform and was designated as measurement 906. The sensitive axis of the accelerometer remained oriented in the direction of the longitudinal axis of the vehicle. Measurement 906 was then flown on each of the subsequent flights. Measurement 950 was a low frequency transducer and was oriented to measure body bending oscillations in the yaw plane perpendicular to the longitudinal axis of the vehicle. This measurement was flown only on MR-BD.

The approximate locations of the various transducers are shown in Figure 6-5. Table 6-4 indicates on which flight the various vibration measurements were flown and the calibration level of the measurement.

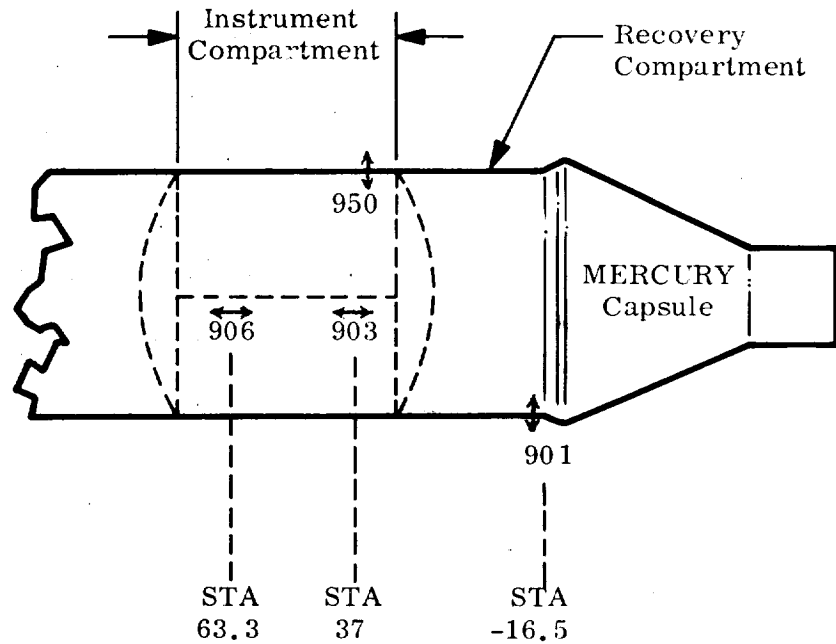

Figure 6-5. Location of Instrument Compartment Vibration Transducers

Table 6-4

Flight Vibration Measurements

Measurement No.	Calibration Range				
	MR-1A	MR-2	MR-BD	MR-3	MR-4
901	+3g	+6g	+12g	+30g	+30g
903	+3g				
906		+6g	+8g	+8g	+10g
950			+0.5g		

6.4.3.2 Measurement 901

The general characteristics of measurement 901 are shown in Figure 6-6. The composite measurement indicates a sharp increase in the vibration level immediately after

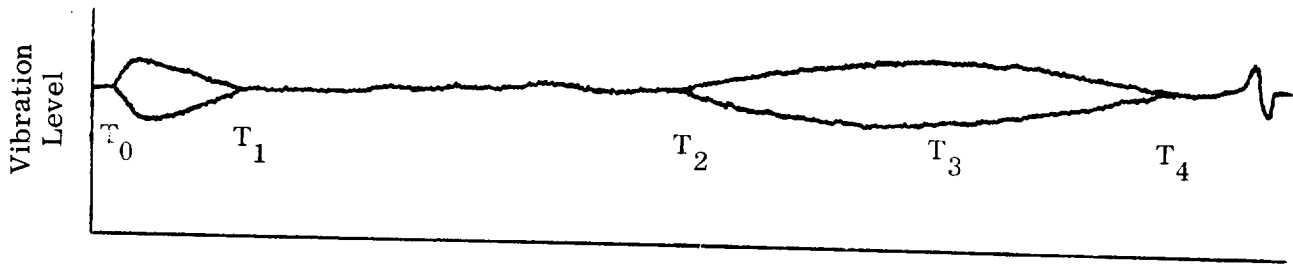

Measurement 901 Vibration Capsule Mounting Ring-Lateral

Flight Number	T ₁ Time Liftoff Vibration Ends		T ₂ Amplitude Increase Starts Seconds	T ₃ Max. Amplitude Reached		T ₄ Time Vibration Returns to Low Level Seconds
	Time Sec.	Max. Mag. G's PK/PK		Time Sec.	Max. Mag. G's PK/PK	
MR-1A	12	*	28	65	*	135
MR-2	10	*	24	68	*	130
MR-BD	7	29.7	37	70	*	130
MR-3	5	30	47	70	58	120
MR-4	6	23.6	43	70	52.4	122

* Measurement System Capabilities Exceeded

Figure 6-6. General Characteristics of Vibration Measurements (901)

ignition (T₀) and during liftoff. The vibration energy for this phase is due mainly to the acoustic environment created by the engine. The level then decreases to a very low magnitude (T₁) until such time (T₂) as the aerodynamic turbulence becomes strong enough to excite the structure after which the level gradually increases to a maximum (T₃) at approximately 70 seconds, when Mach 1 occurs. Thereafter, it decreases gradually to a negligible magnitude (T₄) and remains so until cutoff and separation where a normal transient occurs.

All the trajectories flown were similar except for MR-1A. It is, therefore, valid to compare the measurements made in one flight against those of another. The tabulated information in Figure 6-6 shows the various times and magnitudes of the different characteristics explained above. The magnitude of the vibration levels was lowered only slightly indicating that the material had little effect as far as measurement 901 was concerned. This, however, is to be expected since 901 was mounted on a substantial structure, the adapter ring.

6.4.3.3 Measurement 906

The general characteristics of measurement 906 were very similar to those of 901 and are shown for the various flights in Figure 6-7. Since this measurement was mounted on substructure in the instrumentation compartment proper, it is logical that it was affected the most by the application of the mass dampening compound. By comparing the magnitudes experienced in the MR-4 flight with those of the earlier flights, it was observed that the magnitude decreased by a factor of approximately 3. Since both the measurements were saturated in flights MR-1A and MR-2, no definite comparison was made to the latter flights.

6.4.4 VIBRATIONAL CHARACTERISTICS

The duration of the increase in vibration levels due to the aerodynamic turbulence decreased from approximately 80 seconds to 54 seconds, as the amount of mass dampening material was increased in the instrumentation compartment. The addition

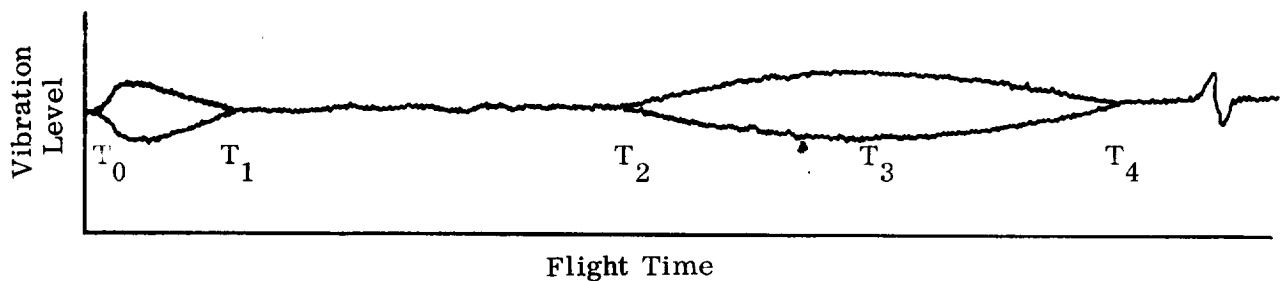

Measurement 906 Vibration LEV-3 Base Plate

Flight Number	T ₁ Time Liftoff Vibration Ends		T ₂ Amplitude Increase Starts Seconds	T ₃ Max. Amplitude Reached		T ₄ Time Vibration Returns to Low Level Seconds
	Time Sec.	Max. Mag. G's PK/PK		Time Sec.	Max. Mag. G's PK/PK	
MR-1A ¹	10	*	40	70	*	120
MR-2	4.5	*	38	65	*	115
MR-BD	5	13.8	50	69	21.8	115
MR-3	4	14	48	70	18	117
MR-4	5	4.2	56	71	6.2	110

1 - Measurement 903 (Vibration Switch, Rate) used here
For Comparison because 906 was not flown on MR-1A.

* - Measurement System Capabilities Exceeded.

Figure 6-7. General Characteristics of Vibration Measurements (906)

of dampening compound, therefore, had two beneficial effects. It lowered the amplitude of the vibration levels, and it shortened the time the critical flight components were subjected to substantial vibration levels.

The vibration environment of the instrumentation compartment was the most severe at Mach 1. Typical vibration spectra for this flight time are shown in Figure 6-8. The spectrum indicates that the majority of the energy lies in the frequency region from approximately 600 to 1200 cps and did not change appreciably from flight to flight. The final spectra of MR-4 was almost flat indicating that there was no appreciable response of the substructure of the instrumentation compartment.

6.5 BOOSTER RECOVERY SYSTEM DEVELOPMENT

6.5.1 GENERAL

One of the more interesting, yet least well-known, aspects of the MERCURY-REDSTONE Project was the design, development, and full-scale testing of a recovery system which

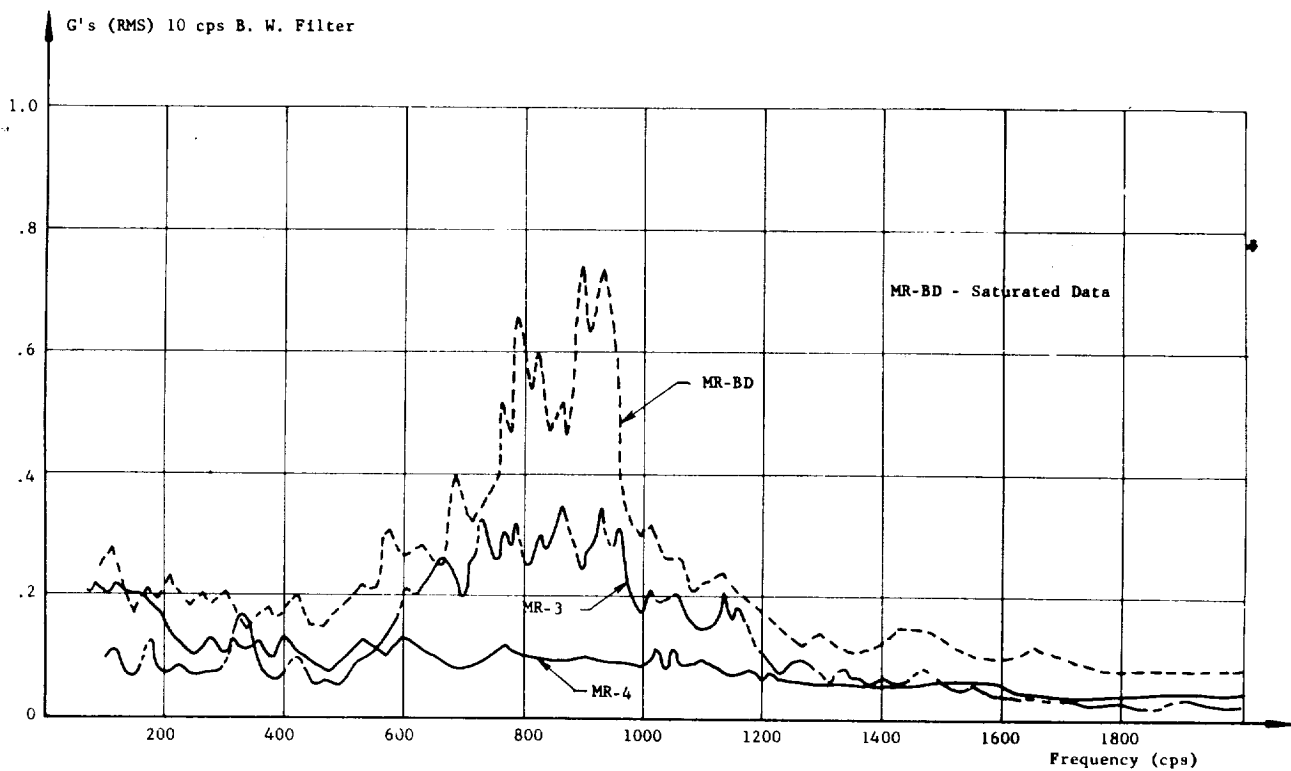

Figure 6-8. Longitudinal Vibration Spectra for MERCURY-REDSTONE Vehicles

would permit reuse of the booster. This project was the first extensive development of a recoverable booster and would have actually been implemented if that portion of the program had not been cancelled because of a lack of funds.

Recoverable boosters and the systems required for such recovery are still of interest today. Present operational analyses indicate that the economics of extensive space operations may necessitate the utilization of the recoverable concept for launch vehicles. Preliminary design studies are already determining the feasibility of recovering large boosters such as the S-IC stage of the SATURN V launch vehicle. As a consequence, the MERCURY-REDSTONE recovery investigations are of significance due to both the technical results achieved and the fact that it was the first such study to be carried through to actual full-scale testing of development hardware.

Although none of the boosters subjected to water impact tests were static fired, sufficient checkout of the propulsion systems was made to determine that they were functional after water immersion. In addition, extensive sea water immersion trials were conducted on a Rocketdyne H-1 engine which was successfully static fired several times following the trials. The general conclusion reached was that sea water impact and immersion would not prevent successful reuse of the booster after cleaning and checkout.

The MERCURY-REDSTONE Program lent itself to a booster recovery development program because of several factors:

- Recovery system space was available.
- The required ballast weight could be replaced with a recovery system, thus lessening the recovery system weight penalty on the primary mission of the booster.
- The REDSTONE booster structure had good strength and flotation characteristics for parachute recovery and landing in water.
- Booster stability problems were as severe during the parachute deployment phase as those which may be expected in future programs.
- Recovery weight was within the state of parachute design, yet high enough to outline areas where future problems may exist.
- Over-all size and weight of the REDSTONE allowed water recovery without extensive modification to available ships and handling equipment.

6.5.2 DESIGN REQUIREMENTS

REDSTONE booster structural data which influenced recovery system design were:

Booster weight (dry)	15,000 pounds
Booster diameter	70 inches
Booster length	700 inches
Maximum load (longitudinal)	8 g
Maximum load (lateral)	3 g
Water impact velocity	40 feet per second (maximum)

The trajectory considerations which influenced recovery system design are given in the following paragraphs.

Booster re-entry attitude was not predictable; the booster could be stable at any angle of attack, spinning, or tumbling at first stage parachute deployment. As a result of the undefined booster attitude, time of flight to impact could vary for a given trajectory. The altitude at which the booster would decelerate to a subsonic velocity could vary between 65,000 feet and 20,000 feet, depending on angle of attack and stability. Therefore, aerodynamic means of sensing velocity or altitude were not suitable for first-stage parachute deployment initiation.

There could be a variation in the cutoff signal of up to ± 8.7 seconds in order to meet the required cutoff conditions in the planned trajectory. These variations were due to variations in engine burning time, mixture ratio, and wind shear effects during powered flight. This range of about 17 seconds prevented use of a program timer for primary recovery system sequencing with a subsonic first-stage parachute deployment.

6.5.3 RECOVERY SYSTEM DESIGN

6.5.3.1 Introduction

The recovery system consisted of a g sensitive switch, a sequencing system, a system to initiate a deployment system, a two-stage parachute system, parachute containers, a structure to distribute the parachute forces into the booster, heat protection, and an instrumentation system to furnish information about recovery system operation to the booster telemetry system. The recovery system was packaged in a self-contained unit. Figures 6-9 through 6-12 illustrate the operation of the recovery system.

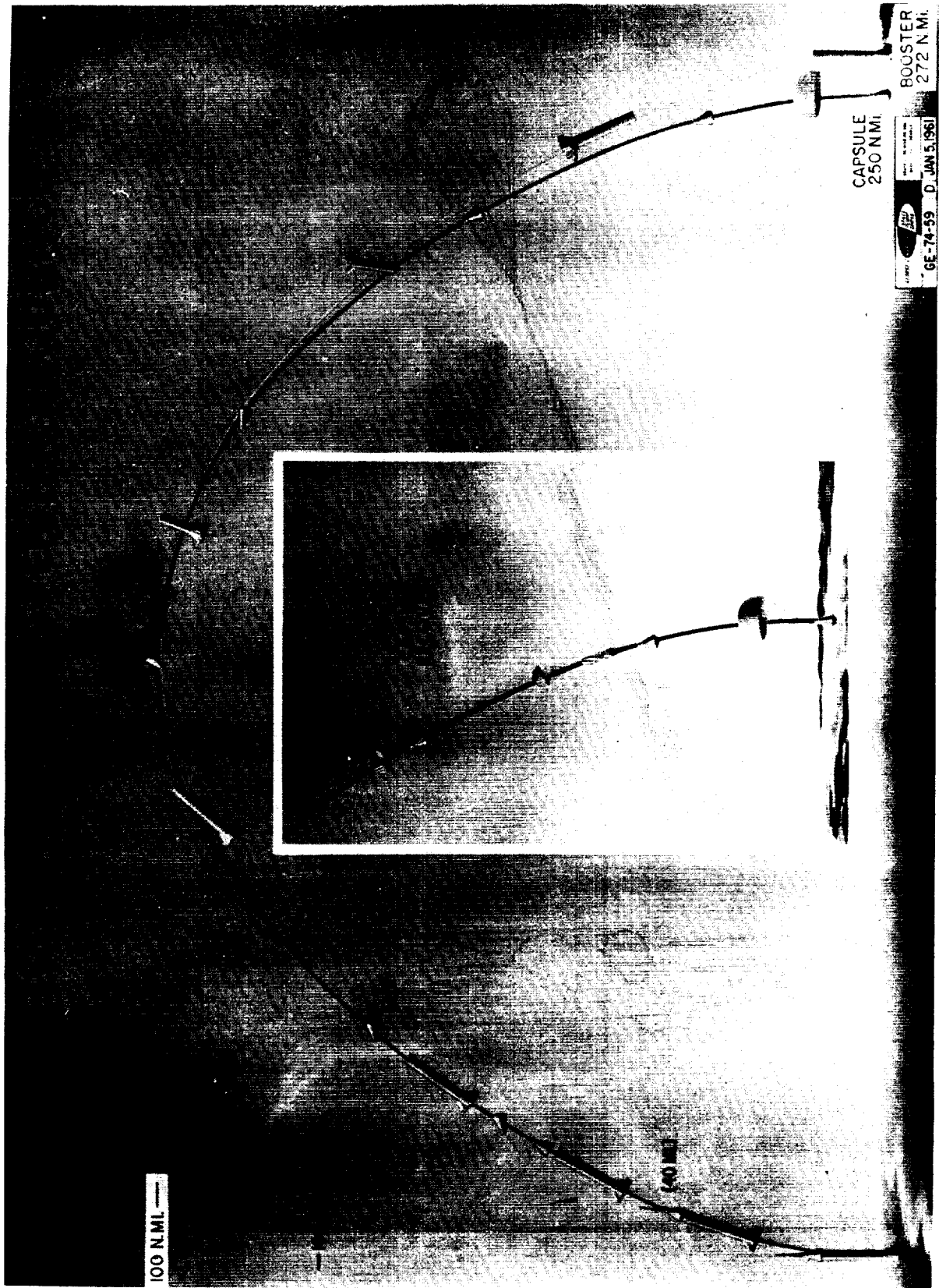

Figure 6-9. MERCURY-REDSTONE Flight Sequence

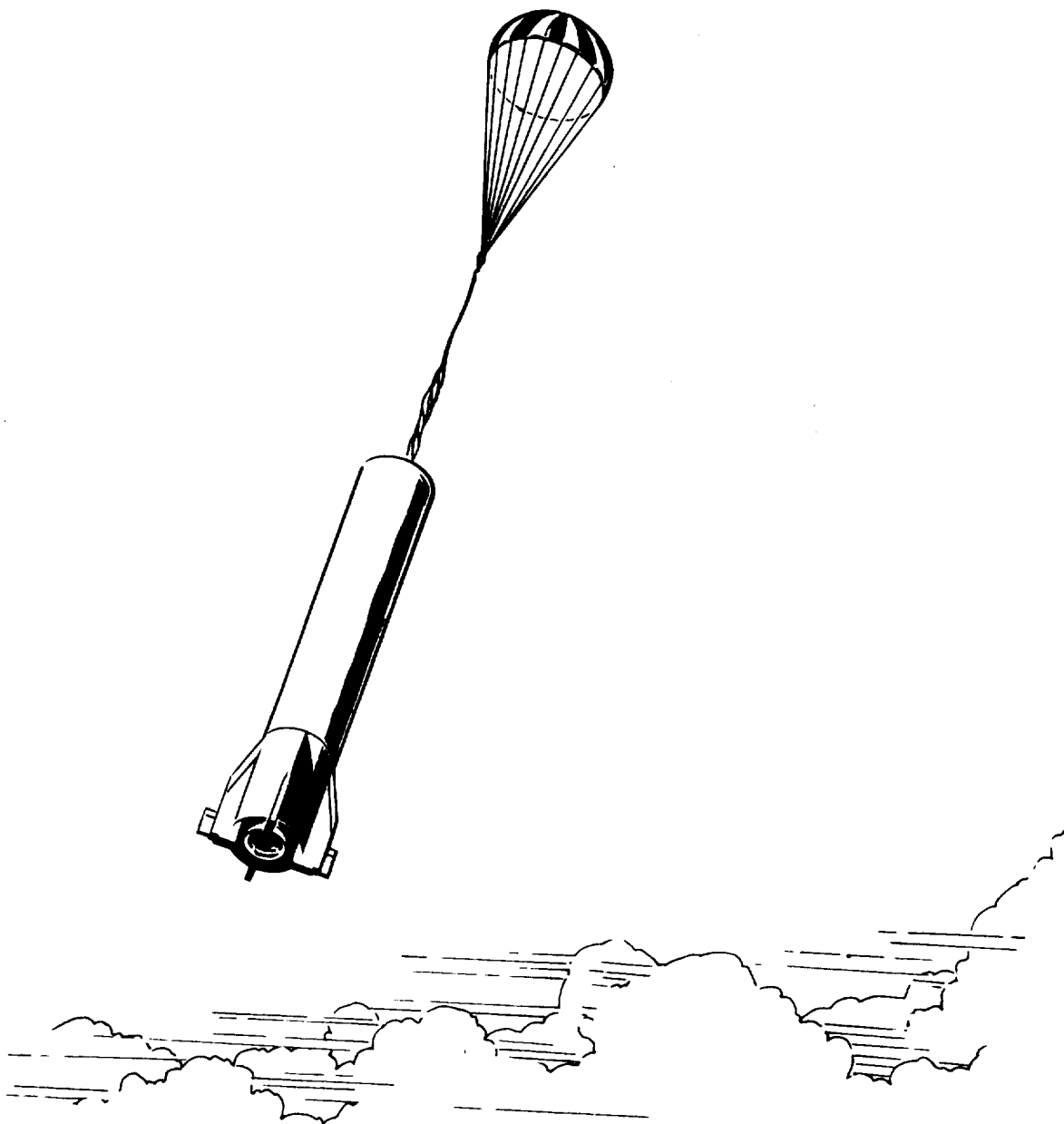

Figure 6-10. Deceleration Parachute Unreefed

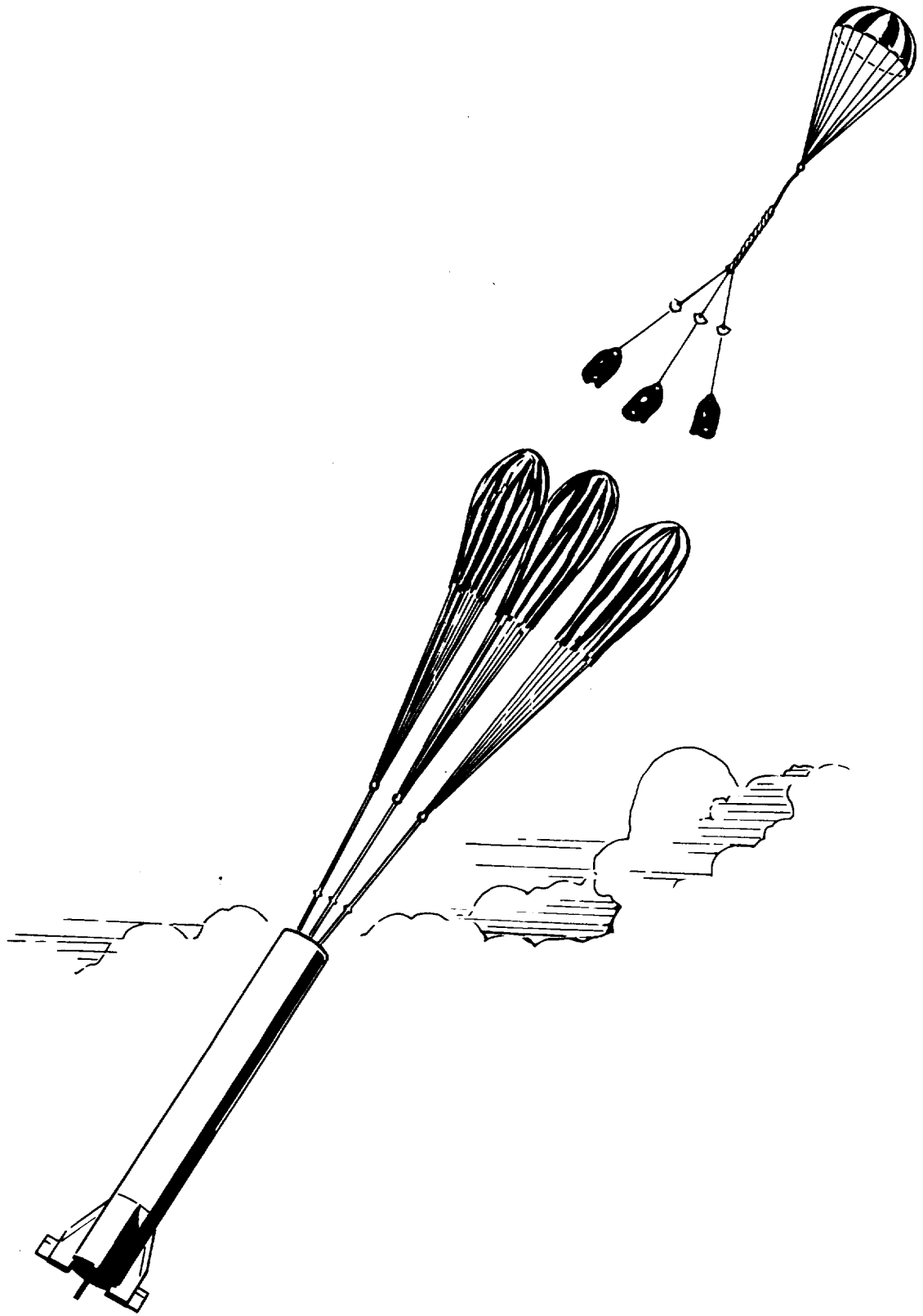

Figure 6-11. Release of Deceleration Parachute and Deployment of Final Recovery Parachutes

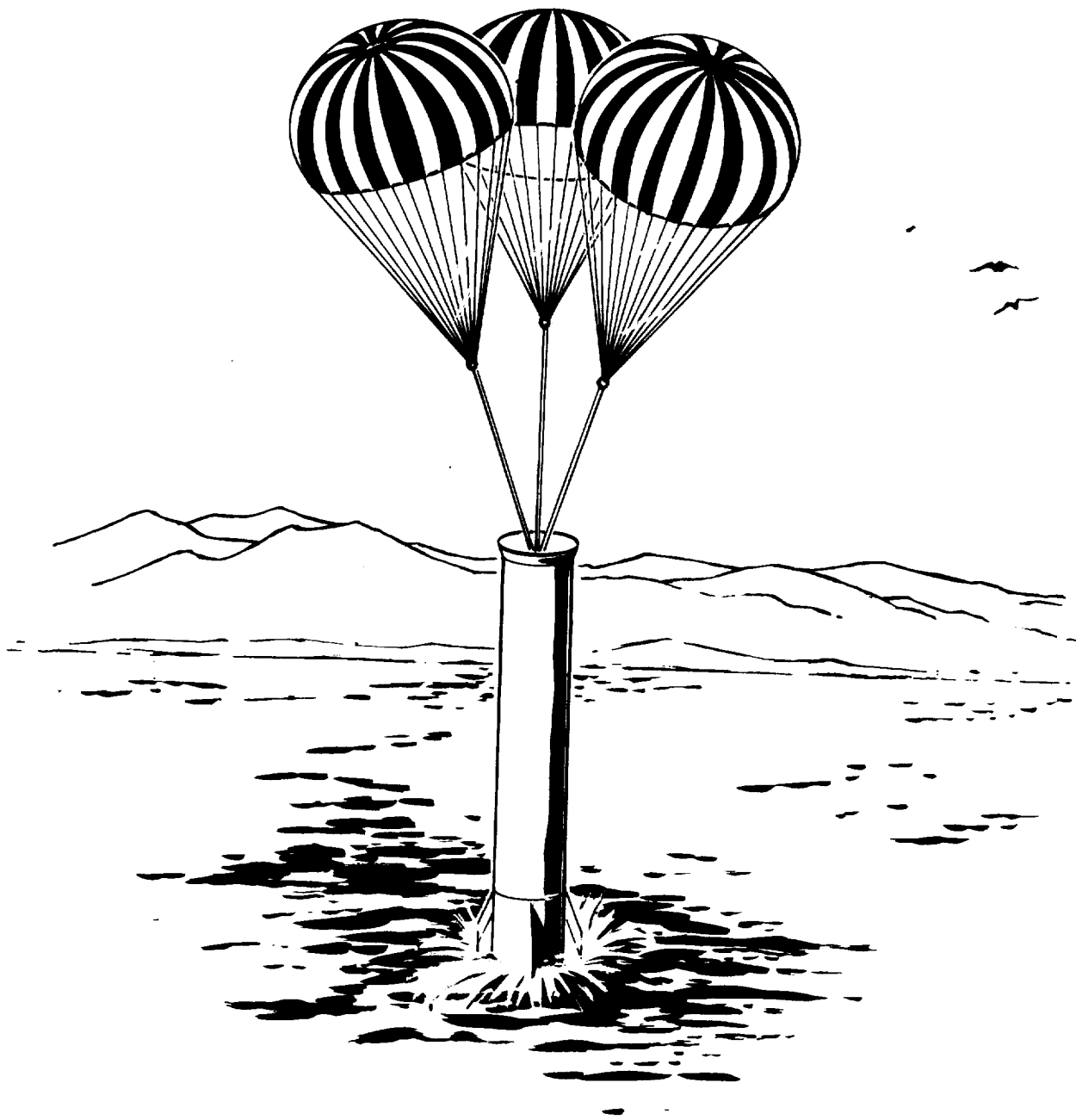

Figure 6-12. Water Impact

6.5.3.2 Sequencing

Regardless of the attitude of fall, the re-entry deceleration peak occurs at a definite time before booster deceleration to subsonic velocity. Thus, with an acceleration sensing device coupled to the timer, it was possible to deploy the first stage parachute into the airstream at high subsonic velocity without regard for booster attitude, altitude, or flight time. The sequencing system as designed, contained, in addition to a g sensing switch, a backup electronic timer (which would start when the REDSTONE program timer ran out) to provide a timed interval sufficient to insure that the booster had decelerated to subsonic speed under all variants of the planned trajectory. At runout of this backup timer, a signal would be given to initiate deployment of the first stage parachute. After the first stage parachute stabilized the booster, the deployment of the three final recovery parachutes was initiated by either of two redundant aneroid switches. The initiation signal from each switch was blocked by the timer for a period of 15 seconds after initiation of the first stage parachute deployment. This delay allowed for the possibility of a late deployment of the first stage parachute in the event that the booster was flying a short-time trajectory at zero angle of attack and had a primary system malfunction. Under these conditions, the booster would have possibly entered the water at greater than the terminal velocity of the final recovery parachutes with the possibility of an unsuccessful recovery.

6.5.3.3 Deployment of Parachutes

The deployment system was designed to use pyrotechnic charges to fire the parachute and its riser with sufficient force to completely extend the riser and initiate parachute deployment within one second. The time limitation selected insured that the parachute would not wrap around a spinning booster. It was estimated that booster rotation would have been less than one-half revolution per second at the time of deployment.

The final recovery parachutes would be deployed by the first stage parachute. Full line and canopy inflation would occur prior to final separation of the first stage parachute.

The first-stage parachute would be deployed in a reefed condition to limit the bending moment on the booster to a value within its structural capability. When sufficient time had passed to orient the booster in a vertical tail-down attitude, the parachute would then be disreefed to allow greater deceleration. When the first stage parachute brought the booster below a 5000-foot altitude, and had been deployed for more than 15 seconds, the rate of descent would have been 300 to 350 feet per second and within the design capability of the final recovery parachutes. At this time the first-stage parachute,

acting as a pilot-chute, would have then extracted and deployed the three final recovery parachutes, which were also reefed to limit the load on the booster. The final recovery parachutes were designed to open in two steps of reefing and to limit the booster's terminal velocity at sea level to approximately 40 feet per second.

6.5.3.4 Parachute Systems

The first-stage parachute was a 17-foot-diameter conical "fist" ribbon type, of high strength design to allow high subsonic velocity deployment. The parachute was attached to a 70 foot long fabric riser which was joined to a 6-foot-long chain riser. The extreme length of riser allowed the parachute to deploy free of the booster regardless of the booster's attitude. The chain riser was necessary due to the sharp lip of the booster-capsule mating joint. The parachute was stowed in a paraflap-type deployment bag which acted as a pilot-chute to insure full stretch of the long parachute riser before releasing and deploying the parachute. To limit its initial opening force to a level which the booster could sustain in any attitude, the first-stage parachute was designed with single stage reefing.

After a time delay sufficient to position the booster in a tail-down vertical attitude, the first stage parachute would have disreefed. It would then open and decelerate the booster to a velocity suitable for final-stage parachute deployment.

The final recovery parachutes were designed as a cluster of three, solid conical canopy, 67-foot diameter parachutes. They attached to individual risers which were permanently attached to the recovery package structure. Since the parachutes were designed for deployment from a stable booster, the riser lengths were of normal length. The final recovery parachutes were arranged for two-stage reefing to permit successful retrieval with one parachute fouled or destroyed, and to limit normal peak loads within the structural strength envelope of the booster.

6.5.3.5 Parachute Containers

The parachute containers and deployment system consisted of mortars for the first stage parachute and its riser, and four fiberglass storage canisters for the final recovery parachutes and their risers.

The first stage parachute was stored in a deployment bag within a pyrotechnic mortar. The top of parachute riser extended from the parachute deployment bag to a deployment bag within the riser mortar. The riser's lower end also extended out of the riser

deployment bag and attached to the chain riser. The chain was attached to an explosive-release mechanism at the center of the recovery unit structure and to a bridle chain of flexible steel cables. The bridle extended to the lids of each of the three final recovery parachutes and single riser canisters. These storage canisters were fabricated of molded fiberglass for thermal protection of the parachutes.

6.5.3.6 Structure

The recovery structure was composed of a conical, six-leg spider with a heavy center hub to which the parachute risers and the first-stage parachute were connected (Figure 6-13). The outer ends of the spokes were attached to the structural attaching ring, and were stabilized by a series of tension members attached to the outer ends of the spokes. The recovery system structure was tested in the MSFC structures test laboratory and proved capable of sustaining and distributing the recovery parachute design loads into the booster structure without damage.

The first-stage parachute disconnect device was attached to the center of the hub of the recovery package structure; the final recovery parachute risers were attached to the center hub. The first-stage deployment mortars occupied two of the six bays between the spokes. The four final recovery parachute system canisters occupied the remaining bays. The electrical system, in two packages, was attached to the mating ring adjacent to one of the access doors of the booster.

6.5.3.7 Heat Protection

Heat protection was necessary to protect the recovery unit from the heat of the separation rocket blast which would have impinged directly upon it. Directly under each nozzle of the separation system was a Dural plate coated with "Refrasil." Over the entire recovery system, under the shields, was a heat protective blanket composed of two layers of heavy fiberglass cloth with an inner layer of glass matting quilted to maintain the blanket's position. A smaller protective blanket of a similar design was installed around the electrical package for additional protection. During first stage parachute separation, the main heat protective blanket would have been removed by the first-stage riser.

6.5.3.8 Instrumentation

Telemetry information to be furnished by the recovery system was limited to temperature, acceleration, and sequencing. The temperature of the outer surface of one of

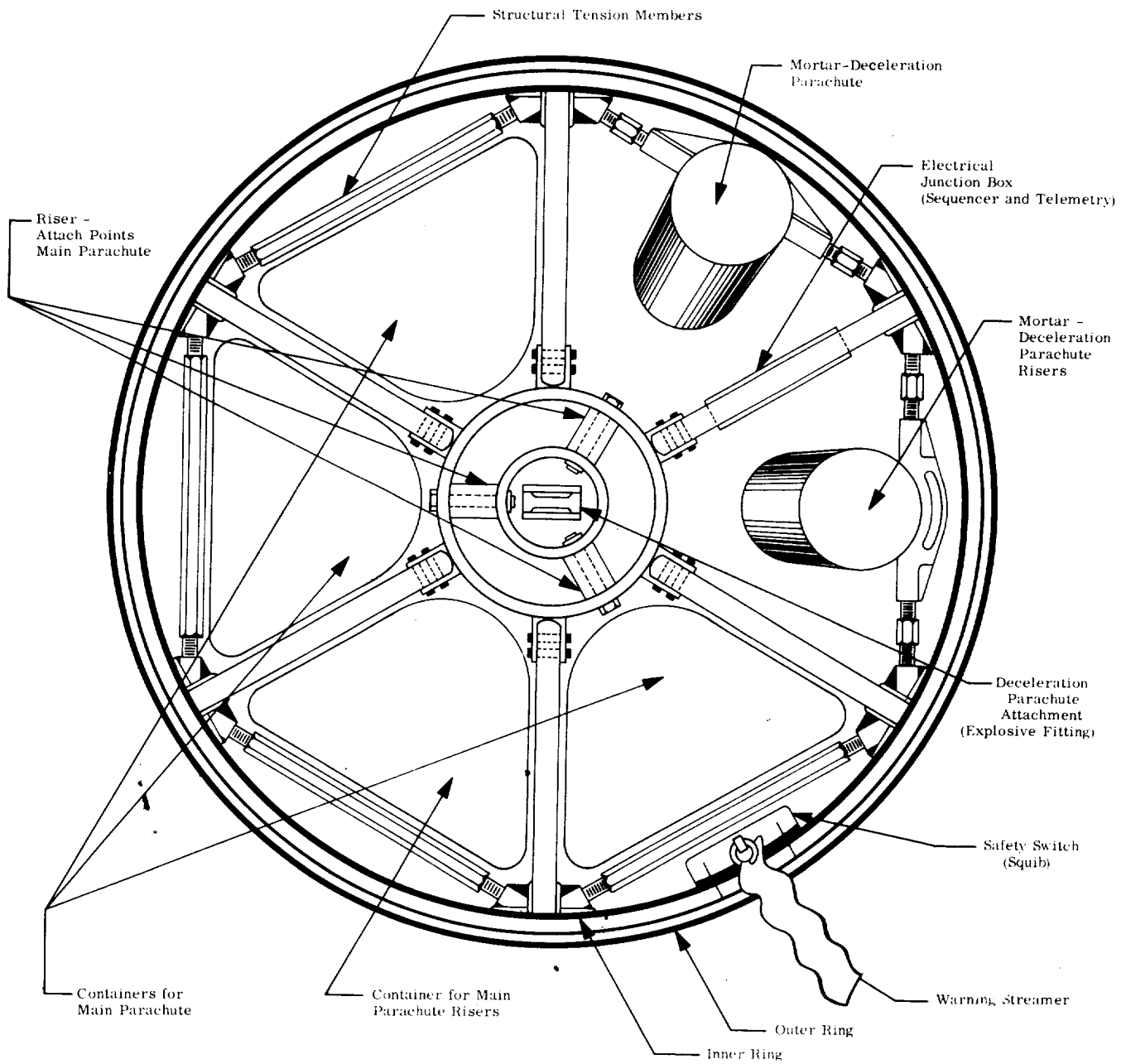

Figure 6-13. Booster Recovery Package

the parachute storage canisters adjacent to the main parachute risers was to be measured. A step-resistance accelerometer network would have telemetered information relative to parachute opening and water entry shock level via means of an output which was to have shown the function of recovery sequencing relative to a time base on the telemetry readout record. The stepping was arranged so that the sequencing readout would have shown whether primary or secondary sequencing operated the system and if sequencing malfunctions occurred.

6.5.4 IMPACT AND FLOTATION TESTS

A major problem in the water recovery program for the MERCURY-REDSTONE booster was the determination of possible damage sustained upon water impact, the angle of flotation, and the depth of submersion. The solution to this problem was necessary to determine the best method of safing and retrieval. To measure the extent to which the booster could withstand water impact, tests were conducted at the Madkin Mountain quarry on the Redstone Arsenal.

The impact and flotation tests were conducted with a four-year-old REDSTONE in the quarry's pond which was approximately 25 feet deep. Prior to the test, the booster was altered in weight and configuration so as to simulate MERCURY-REDSTONE booster retrieval conditions. The nose section and all instruments in the aft unit were removed, and a special bulkhead was added for waterproofing and handling purposes.

A carpenter's level and protractor were used to measure angle of flotation of the booster, and a steel tape was used to measure depth of submersion. The depth of penetration of the booster into the water was obtained by using a high-speed camera to photograph a scale printed on the skin of the booster.

During these tests the booster was:

- Floated with fuel and LOX tanks empty.
- Floated with 900 pounds of water in both the fuel and LOX tanks which were pressurized to 10 and 25 psi, respectively. Water was used to simulate probable residual fuel and LOX in tanks after re-entry and impact.
- Dropped from a height of 3 feet to check the instruments and to determine possible damage to the booster.

- Both the LOX and fuel vented with specially designed device, making sure the operator kept his face away from the vent during venting.
- H₂O₂ vent and overflow tee capped on one side by a female Roylyn connector. The other side was capped with a male Roylyn connector plus relief valve which provides means for venting the system in the event of internal reactions.
- Dropped from a height of 25 feet to obtain an impact velocity of 40 feet per second, or the estimated impact velocity of the MERCURY-REDSTONE booster upon re-entry when equipped with parachutes.

The maximum vertical acceleration measured during the drop from 25 feet was 13.94 g's and occurred approximately 1/25 second after contact with the water and at a point when the booster had, by calculation, penetrated to a depth of 18 inches and had been decelerated to a velocity of 34.6 feet per second. Since the booster initially traveled at 40 feet per second, one fourth of the kinetic energy had been transferred to the water. The depth of penetration is shown in Figure 6-14. Maximum penetration was 17 feet 4 inches. A trace of the vertical acceleration versus time is shown in Figure 6-15.

Moderate damage was sustained by the fuel tank and the tail unit as a result of the drop tests. The damage was limited to buckling of the skin in the fuel tank section, which, however, remained pressure tight despite the damage. Also, seams in the tail unit burst due to shearing of the rivets.

Calculations prior to the test estimated the angle of flotation of the booster, in a dry condition, to be 4 degrees and the depth of submersion of the aft end to be 81 inches. The actual angle of flotation measured was 2.2 degrees and submersion was 70 inches. With the tanks pressurized and containing residual fuel, the booster floated at 3.2 degrees and was submerged 80 inches at the aft end. The variance of the actual from the pretest calculations was attributed to the buoyancy of the tail unit and rocket engine assembly which were not previously considered.

The final center of gravity of the booster after impact was directly below the longitudinal centerline and was slightly off fin IV toward fin II. This favorable condition meant that the skindivers, with the aid of auxiliary equipment, were able to rotate the booster to any desired position and facilitate safing procedures.

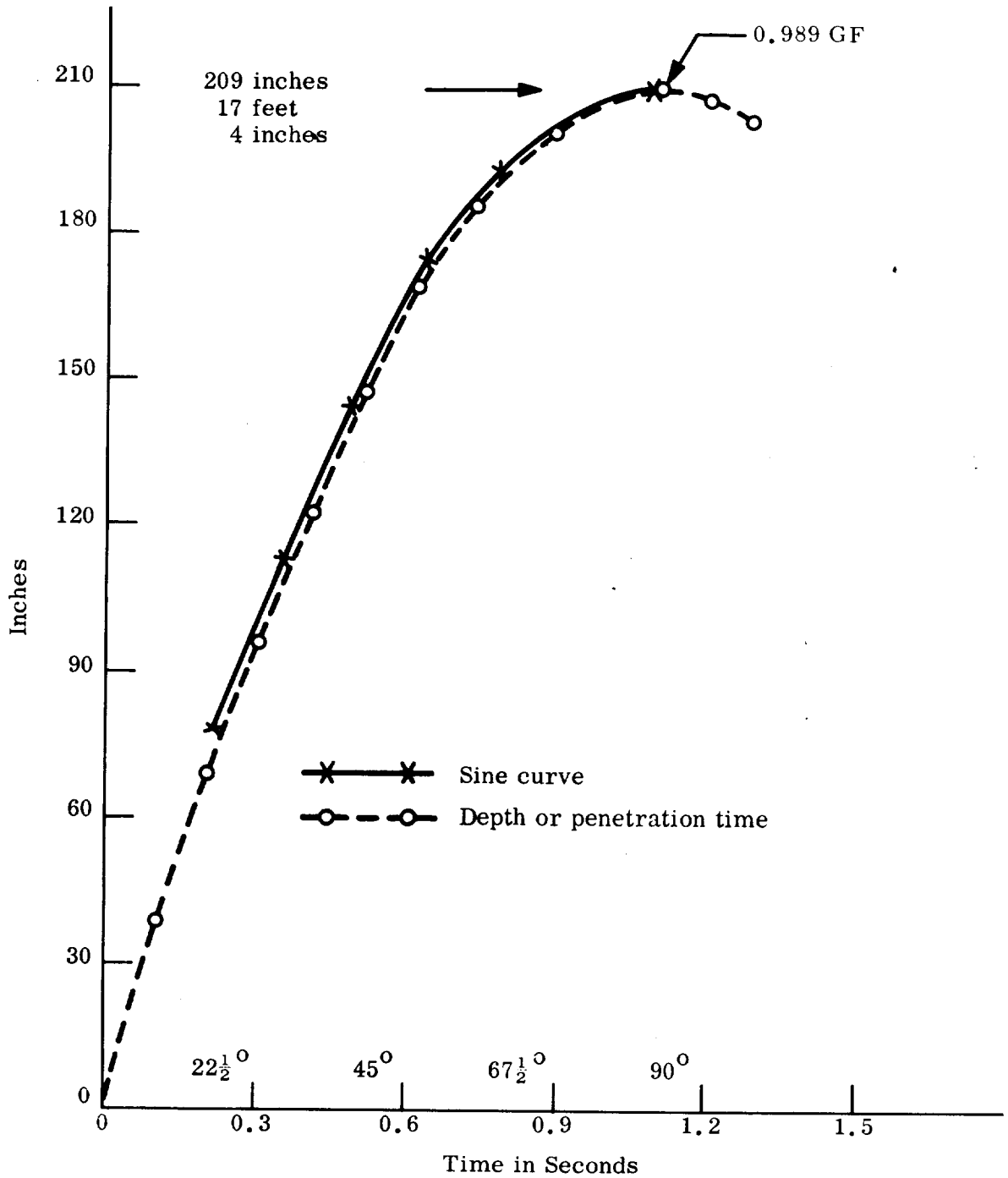

Figure 6-14. Penetration in Inches versus Time in Seconds Showing Close Fit of Sine Curve

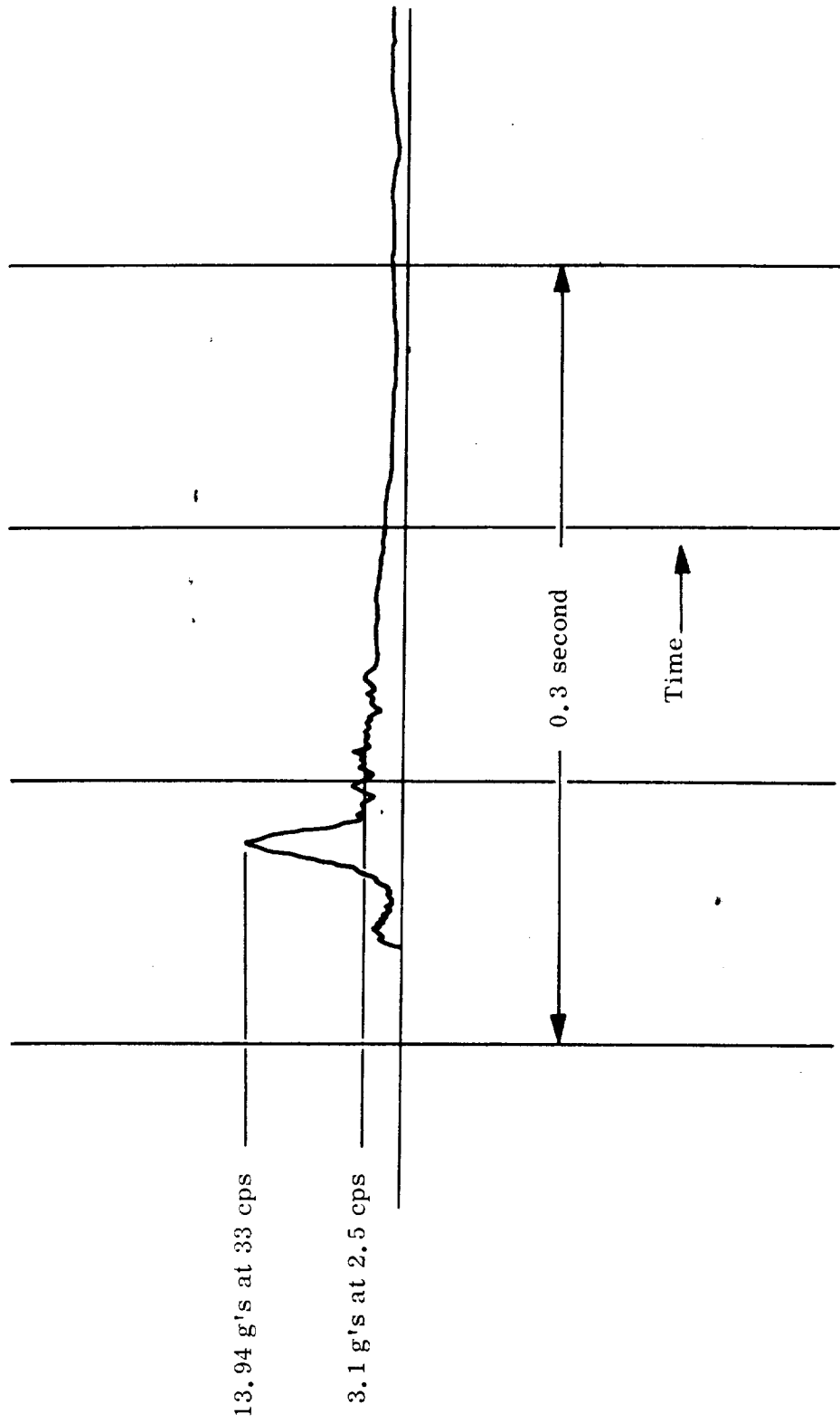

Figure 6-15. Accelerations Measured Vertically on MERCURY-REDSTONE Drop Test

6.5.5 SAFING SEQUENCE TESTS

In parallel to the impact and flotation tests, the proper procedures were established for safing the booster prior to floating aboard the recovery vessel.

To simulate water recovery, the booster was first lowered into the water and then was pressurized with GN₂. The LOX tanks was pressurized to 30 psig, the fuel tank to 10 psig, and the air pressure spheres to 800 psig. After the pressurizing the booster was permitted to float for approximately 30 minutes. Following the waiting period:

- Airbags were attached to stabilize the booster and to provide accessibility to the destructor unit.
- The destructor unit was checked to assure that it was in its SAFE mode.
- The booster was rotated until the LOX fill and drain valve and the fuel fill and drain valve were accessible.

6.5.6 SEA TESTS

An actual recovery from the sea was performed as part of the test program using handling procedures which had been developed and practiced in the quarry test. The results of the tests which were conducted in the Atlantic ocean were:

- The REDSTONE booster could be retrieved by United States Naval Vessels with available handling equipment.
- Salt water deterioration to the booster after maximum expected submersion can be kept to a minimum by flushing with a fresh water hose immediately after retrieval.
- Surprisingly little additional rework to the booster is required because of the salt water submersion.

The sea tests were conducted during a two day exercise 50 miles from Norfolk, Virginia. An eight-man underwater demolition team, equipped with hand tools, lines, and replacement fill valves, assisted a landing craft crew in four retrievals of the booster. After safing, the booster was floated onto special cradles attached to the submersible well of a Landing Ship Dock (LSD). The well was then emptied permitting flushing of the booster.

The first recovery operation took place under excellent weather conditions. Ceiling and visibility were unlimited; wind was from the southwest at about 8 knots, with a slight swell from the south.

The primary objective of this first retrieval attempt was to check out the proposed handling procedures. As the first step, the booster, swimmers, and their rubber boat, and the towing crew aboard the Landing Craft Vehicle Personnel (LCVP) were launched. The LSD drained the well and moved away several thousand yards. The swimmers then approached the booster and went through the safing procedures without any difficulty, and also installed the handling connections.

After the safing operation was completed the booster was taken in tow by the LCVP and positioned astern the LSD which was maintaining a constant heading toward the sea. The LSD was ballasted so as to have 8 feet of water in the well at the stern gate sill. The LCVP continued towing until its bow was over the LSD stern gate then reversed, disconnected its tow line, and moved off to the port side and stood by. Swimmers with lines from the LSD attached lines to prescribed connections on the booster, and the booster was positioned over saddles. Once the booster was positioned, deballasting of the well proceeded until booster rested firmly on saddles. After the well was drained, the booster and recovery equipment were checked for damage.

The second operation omitted the safing procedure, but went through with towing the booster out and back into the LSD with the LSD maintaining a heading of 2 to 3 knots into the waves. While the booster was floating at sea, a P2V aircraft was conducting visual training, establishing radar tracking limits, and taking aerial photographs of the operation.

The third operation was very similar to the second. A change on the tiedown location of the nylon retaining slings was made. The slings were positioned so that they went up and over the booster to the opposite wing wall instead of under, around, and over the booster to the wind wall as in the first two operations.

The fourth and final operation was a complete simulated recovery. The booster was set free and all personnel stayed aboard the LSD. The LSD deballasted and steamed off ten miles from booster. At ten miles the booster was held on surface radar while the P2V at a 1500-foot altitude, tracked it a distance of 50 miles.

Once the tracking exercises were over, the LSD started toward the booster. Ballasting of the LSD and preloading of the LCVP were performed while enroute. When the

LSD was approximately 1000 yards from booster, the LCVP was launched and proceeded to the booster. Upon arriving at the booster, the swimmers went through the safing operation; the booster was taken in tow, and brought into the well of LSD and positioned as before.

SECTION 7

CHECKOUT AND LAUNCH OPERATIONS

7.1 PRELAUNCH PREPARATION

7.1.1 GENERAL

Original plans for the MERCURY-REDSTONE vehicle provided for preliminary mating and checkout under laboratory conditions at MSFC prior to delivery to Cape Canaveral Missile Test Annex (CCMTA). This procedure was followed with the first two vehicles, after which it was decided that sufficient experience had been acquired to eliminate test of the mated vehicle at MSFC. It was also originally planned to have a first and second mate at CCMTA for verification of the assembled vehicle with GSE, final preparation of the spacecraft, second mate, and launch, in that order. Experience with the MR-1 vehicle indicated that this procedure was not necessary, and subsequent flights were scheduled for one CCMTA mate only. By the time of the MR-3 flight, launch vehicle delivery was approximately four weeks and capsule delivery approximately fifteen weeks prior to launch for conducting checkouts.

7.1.2 PRELAUNCH TESTS

With the exception of launches MR-1 and MR-1A, the spacecraft and the booster arrived at CCMTA separately from St. Louis and MSFC, respectively. The adapter used between the spacecraft and booster, was manufactured by McDonnell Aircraft Company (MAC), shipped to MSFC for a fit test on the particular booster with which it was to be used, then sent to CCMTA where it was fitted to the spacecraft. The launch pad was rehabilitated and the GSE checked out prior to arrival of the launch vehicle. By the time of the MR-4 flight, booster procedures progressed to the point that the launch vehicle was confidently erected on the pad without undergoing hanger checks.

Mechanical mate occurred about 16 calendar days before launch, which provided sufficient time for exhaustive composite vehicle checkout procedures. Following launch vehicle erection, electrical connections were made and continuity checks and bus calibrations performed. During the period between launch vehicle erection and mate, mechanical tests, component calibrations, and measuring component checks were conducted under a schedule predicated on availability of personnel and phasing-in of

booster tests. The diagram in Figure 7-1 shows the building-block approach used in scheduling the MERCURY-REDSTONE launch site checkout. The double asterisks indicate combined spacecraft-launch vehicle tests, and the single asterisks indicate launch vehicle-GSE systems tests.

- Malfunction Sequence Tests

These tests verify proper operation of cutoff circuits by simulated malfunctions. During the automatic sequence, RF, navigation, and gyro systems are not ordinarily operated.

- Guidance and Control Over-all Test

This test is conducted to verify proper operation of all vehicle systems. All systems of both spacecraft and launch vehicle are operated. Umbilical release and retraction is simulated, and ordnance systems monitoring is performed.

- Guidance and Control Plug Drop Over-all Test

This test verifies the compatibility and proper operations of all vehicle systems while simulating the firing as closely as possible. All systems of all stages are operated, the umbilicals released and one-shot relays and explosive switches are fired. Range support is required for this test.

- Simulated Flight Test

This test is conducted to verify compatibility and proper operations of all vehicle systems. Umbilical release is simulated, all systems of spacecraft, vehicle, and range are operated, and ordnance systems are monitored. Range support is required for this test.

- Booster Integrated Test

Booster integrated test includes network, mechanical, and measuring over-all tests. Command receivers are normally operated but all other RF systems, gyro systems, and navigational systems are not operated. These tests are normally conducted in preparation for the final combined systems over-all test such as the guidance and control over-all test, the plug drop over-all test, and the simulated flight test. Individual major tests are indicated in separate blocks and are adequately defined by their titles.

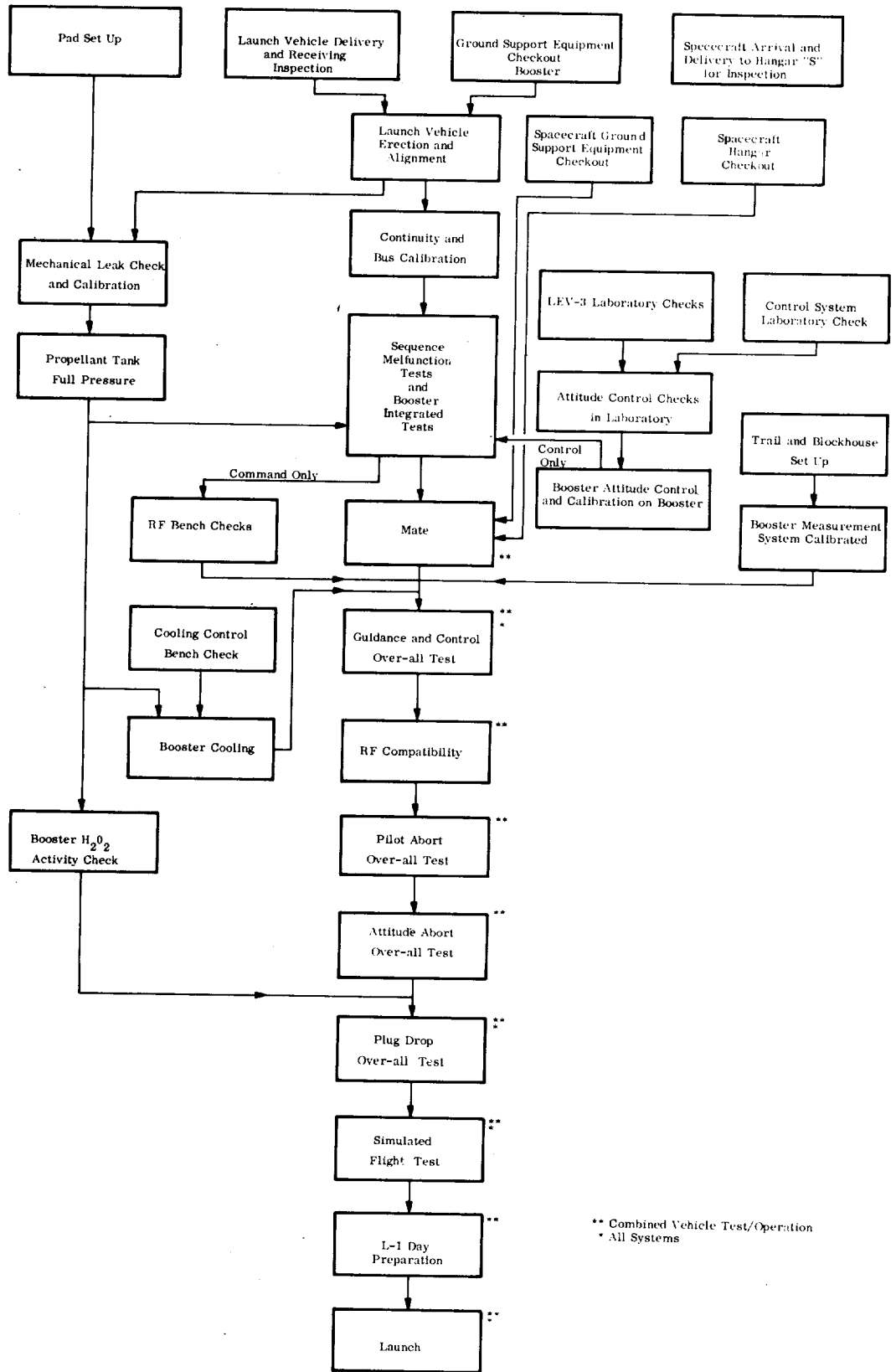

Figure 7-1. Launch Site Checkout Scheduling

Mechanical prelaunch checkout of the booster vehicle was carefully conducted under the direct supervision of the responsible design engineer. Approximately 18 mechanical tests were conducted. Each test entailed preparatory steps and specific operating procedures. A list of such tests by descriptive titles follows:

- Functional test - Fuel tank pressure switch.
- Functional test - Engine control pressure switch.
- Functional test - Combustion chamber pressure switches 1 and 2.
- Leakage test - High pressure system.
- Leakage test - Engine and ground control pressure systems.
- Leakage test - Hydrogen peroxide system.
- Leakage test - Steam exhaust system and turbopump functional test components test.
- Leakage test - Igniter fuel system.
- Pressure test - Propellant tanks simulated full.
- Leakage test - LOX system.
- Leakage test - Fuel system.
- Leakage test - Combustion chamber.
- Pressure test - LOX and fuel tanks full.
- Leakage test - Combustion chamber pressure switches sensing lines.
- Functional test - LOX replenishing system.
- Leakage test - Instrument compartment.
- Activity test - Rocket engine hydrogen peroxide system.

7.1.3 SCHEDULE OF PRELAUNCH ACTIVITIES

Throughout the MERCURY-REDSTONE Program, procedures were adjusted to provide for a more effective operation, based on experience and familiarity with the launch vehicle. The final schedule of launch vehicle checkout procedures for the MR-4 launch encompassed 21 workdays, compared with 46 workdays on MR-1. The checkout history of MERCURY-REDSTONE vehicle MR-4 was utilized in establishing the chronological sequence of operations listed below. The operations are listed by calendar days, L indicates launch day and the number indicates days prior to launch day.

- L-25 Booster arrival and erection on launcher. Cable masts erected, vertical alignment, and positioned to flight azimuth.
- L-24 Apply electrical power and operational check of command receivers. Begin measuring calibration and mechanical preparations.

- L-23 Mechanical systems test, including component and leak tests. Laboratory calibration of abort rate switches. Measuring calibration continued.
- L-22 Not a work day.
- L-21 Continue mechanical checks and measuring calibration. Check telemetry, AZUSA, and DOVAP.
- L-20 Full pressurization test. Program device checks and verification.
- L-19 Booster over-all test number 1 as follows:
 - a. Ready-to-fire failure cutoff.
 - b. Ignition failure.
 - c. Destruct command receiver.
 - d. Cutoff arming to capsule.
 - e. Install booster recovery package ballast.
- L-18 Functional cooling system check, gyro control tests.
- L-17 Complete cooling test.
- L-16 Mechanical mate of spacecraft to booster.
- L-15 Not a work day.
- L-14 Electrical mate of spacecraft and booster, over-all test number 2, and off-the-pad abort test.
- L-13 Over-all test number 1, normal flight sequence.
- L-12 Partial RF compatibility test, astronaut insertion procedures, and booster peroxide system activity test.
- L-11 Complete RF compatibility test, and conduct egress tests.
- L-10 Not a work day.
- L-9 Not a work day.
- L-8 Over-all tests as follows:
 - a. Over-all test number 3, emergency override test.
 - b. Over-all test number 4, pilot abort test.
 - c. Over-all test number 5, attitude abort test.
- L-7 Evaluation of over-all tests 3, 4, and 5. Verification of any questionable areas.
- L-6 Plug drop over-all test.
- L-5 Preparation for simulated flight test, and booster ordnance item fit checks.
- L-4 Simulated flight test.
- L-3 Booster instrument compartment pressurization test, and booster flight safety, and mission review meeting.

- L-2 Not a work day.
- L-1 First portion of divided countdown.
- L-0 Weather briefing, second portion of countdown, and launch.

7.2 LAUNCH ORGANIZATION AND COUNTDOWN

7.2.1 RESPONSIBILITIES

7.2.1.1 General

Figure 7-2 shows the MERCURY-REDSTONE launch organization as it evolved for the flight of MR-4. The broken lines enclose the blockhouse functions, the solid connecting lines show the lines of action, and the dashed connecting lines are lines of coordination.

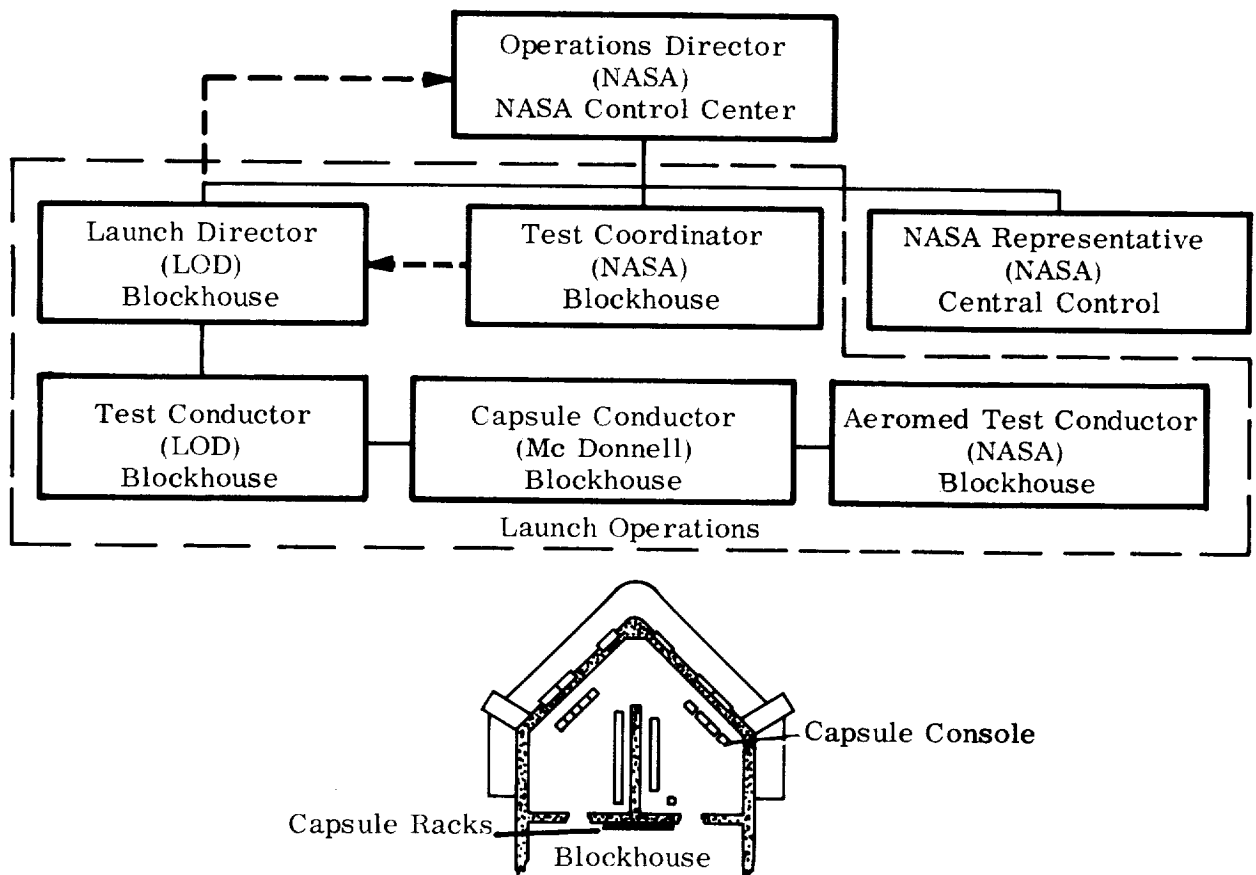

Figure 7-2. MERCURY-REDSTONE Launch Organization

7.2.1.2 Operations Director

Over-all mission control was exercised by the operations director. In carrying out this responsibility, he was supported by the launch director and flight controller. A delineation of responsibility and support functions are presented in a document entitled Over-all Plan, Department of Defense Support for Project MERCURY Operations prepared by the Department of Defense (DOD), representative for Project MERCURY, dated 15 January 1960. At the MERCURY Control Center (MCC), the operations director received information from the launch director, tracking and data acquisition network, recovery organization, launch coordinator, and the flight controller. Through a representative in the MCC, the blockhouse kept the operations director advised of booster progress and principal events throughout powered flight.

7.2.1.3 Launch Director

The launch director was responsible for the technical readiness of the launch vehicle system, the launch complex, AMR support, and for accomplishment of launch objectives. Technical problems concerning the capsule and astronaut relating to the mission were referred to the operations director for decision. The launch director had responsibility for the countdown, abort command to liftoff plus eight seconds, emergency egress, and he was responsible for monitoring the powered flight of the launch vehicle until spacecraft separation. The launch director had technical supervision of the launch operation. The test conductor reported to the launch director, and in turn was supported by a capsule test conductor. A single action point of contact with AMR operations was maintained through the test conductor to assure that all information emanating from the blockhouse was complete and properly coordinated to eliminate the possibility of contradictory or overlooked support requirements.

7.2.1.4 Test Conductor

The test conductor also acted as the launch vehicle test conductor and was supported directly by the launch operations range coordinator, the blockhouse and complex launch vehicle systems engineers, and contractor personnel involved in the launch operation. The capsule test conductor, in turn, was supported by a capsule systems engineer, a capsule communicator (one of the astronauts), and aeromedical personnel. The capsule systems engineer coordinated the pad and blockhouse activities of McDonnell personnel in support of the launch operation.

7.2.1.5 Range Coordinator

The launch operations range coordinator was in continuous communication with the superintendent of range operations to assure that the AMR countdown was in phase with, and properly supporting, the entire launch function.

7.2.2 MISSION RULES AND LOD SCRUB PRIORITY LIST

Two additional important documents that were used during the MERCURY-REDSTONE launch countdowns were the mission rules and LOD scrub priority list shown in Table 7-1. The LOD scrub priority list established priorities for booster onboard equipment and instrumentation. This priority list was used as a quick reference guide to a hold or scrub in case of foreseeable booster or GSE malfunctions. It also listed weather criteria and range safety requirement for the launch. The mission rules provided similarly appropriate priorities for the spacecraft systems and the MCC.

Table 7-1
MERCURY-REDSTONE Mission Rules and Scrub Priority List

Action	Commands	Remarks
Abort	<p>Abort of the mission will only be commanded:</p> <ul style="list-style-type: none"> a. From the blockhouse: On the basis of impending booster catastrophic failure either on the pad or during powered flight. b. By the RSO, for range safety reasons during powered flight. <p>Capsule or booster malfunctions will not be cause for abort command from control center.</p>	<p>Booster abort system installed open loop on MR-1, 1A, and BD. (Abort system is open loop on flights MR-1, 1A, and BD only.)</p> <p>Blockhouse monitors booster by telemetry.</p> <p>Blockhouse abort command is to capsule command receivers only.</p> <p>RSO Commands:</p> <ul style="list-style-type: none"> a. Booster engine shutdown. b. Booster destruct: (3-second time delay built into booster between shutdown and destruct arming).

Table 7-1

MERCURY-REDSTONE Mission Rules and Scrub Priority List (Cont.)

Action	Commands	Remarks
Retrofire	Retrofire will be commanded by control center. <p style="text-align: center;"><u>Blockhouse</u></p>	Onboard timer will be considered as backup.
Booster telemetry displays - for abort control	Mandatory.	
Command	Mandatory. <p style="text-align: center;"><u>Recovery Forces</u></p>	
Capability	Recovery is mandatory. <p style="text-align: center;"><u>Weather Minima</u></p>	
Launch area	Surface winds - 18K maximum, Upper winds - 120K maximum at any altitude. Sea state - 3 or calmer. Visibility - 5 miles. Cloud coverage - no cloud coverage that will preclude camera coverage of booster operation from liftoff through separation. <p style="text-align: center;"><u>Range Instrumentation Support</u></p>	Capsule impacts predicted to occur in an unsatisfactory landing area may be the basis for a no-go decision. Countdown action if instrumentation fails during count.
Flight safety	AZUSA Mark I Beat-Beat Mark II Telemetry ELSEE Mod IV radar Mod II radar (S-band, SCR-584) FPS-16 (C-band) Station 1-16 (Cape) FPS-16 (XN-2, C-band) Station 3-16 (GBI) FPS-16 (XN-1, C-band) PAFB-Stanley FPS-8 Surveillance radar FPS-20 Surveillance radar sky screen, vertical wire Command system	Hold Proceed Proceed Proceed Proceed Hold Proceed Proceed Proceed Proceed Hold

Table 7-1

MERCURY-REDSTONE Mission Rules and Scrub Priority List (Cont.)

Action	Commands	Remarks
Electronic instrumentation	MPS-25 (Carter Cay C-band) FPS-16 (XN-1, PAFB) DOVAP (uprange) transmitter DOVAP-blockhouse, receiver Tel-2 (TCM-18) telemetry antenna Telemetry ship Telemetry aircraft (1 required)	Proceed Proceed Proceed Proceed Hold Hold
Optical tracking instrumentation (see Weather)	Documentation and sequential Metric cameras Cine theodolitic (Askania) CZR cameras ROTI (Melbourne and Vero Beach) ROTI Melbourne Beach ROTI Vero Beach IGOR PAFB IGOR False Cape IGOR, Williams Point	Proceed Proceed Proceed Proceed Proceed if one operates Proceed if one operates Hold if both are out Proceed Hold Proceed
Primary and Secondary Recovery Area: Ceiling - 2000 feet Visibility - 5 miles Surface winds - 18K		

7.2.3 LAUNCH COUNTDOWN

7.2.3.1 Countdown Procedures

To prevent personnel fatigue, the 10-hour MERCURY-REDSTONE countdown was performed in two parts. The first of these parts was performed on the day preceding launch day and covered the operations normally performed from T-640 to T-390 minutes of the countdown. The second part began at approximately 2300 hours on the day preceding launch (including built-in holds) and covered the operations normally performed from T-390 minutes of the countdown until vehicle liftoff. This system of operation afforded the launch crew several hours of rest at approximately midway in the count. As a result, the crew was less fatigued and more alert during the critical launch time when proper response is most essential. On those occasions when a launch was scrubbed and rescheduled after the first section of the count had been completed, only the second portion of the count was performed if the launch was rescheduled within a short period of time.

To assure that all functions during a countdown were properly integrated, the responsibility for such integration was assigned to the over-all test conductor. Scheduling of prelaunch tests was similarly accomplished. The launch vehicle test conductor prepared the master operational schedule following coordination with STG, AMR, LOD, and other participating organizations. Countdown procedures on the capsule were prepared in detail by McDonnell Aircraft Company and were closely coordinated with the over-all launch countdown to assure the timely phasing-in of capsule operations. The master operational schedule was considered the master document, and the AMR and procedure were geared accordingly.

Detailed countdown procedures were written for use in checking out the many systems and subsystems of the capsule and booster. The countdown document included each key procedure of major importance and each was identified by the title of the responsible individual in the countdown. These procedures appeared at the proper time and in proper sequence in the count. As each test or procedure was completed, the cognizant engineer reported the fact to the test conductor who then checked it off the list.

Due to unforeseen developments, some last minute requirements are normally written into all affected launch procedure documents. Experience gained in earlier operations indicated that rapidly changing weather conditions could cause a delay such that it became necessary to scrub the launch. A scrub prior to LOX loading required only re-scheduling the beginning of the next countdown. A scrub after LOX loading required emptying the LOX and purging and drying the launch vehicle, the process requiring approximately 12 hours. The precount and final count could then begin subject to the target launch crew rest requirements. It was decided, therefore, that LOX loading would be delayed to occur as close to vehicle liftoff as feasible. As a result, the LOX loading time was shifted from T-305 minutes to T-180 minutes in the countdown. This change was made between the MR-3 and MR-4 launches. A bar chart of the schedule of countdown procedures and launch vehicle status for the MR-4 launch is presented in Figure 7-3.

7.2.3.2 Detailed Countdown Schedule (MR-4)

The following pages present the complete countdown schedule for the MR-4 launch. An explanation of the code utilized to identify responsibilities (e.g., PAD-M) is given at the conclusion of paragraph 7.2.3.2. Part I details from T-640 down to T-390 minutes, Part II, details T-390 minutes through T-0 liftoff.

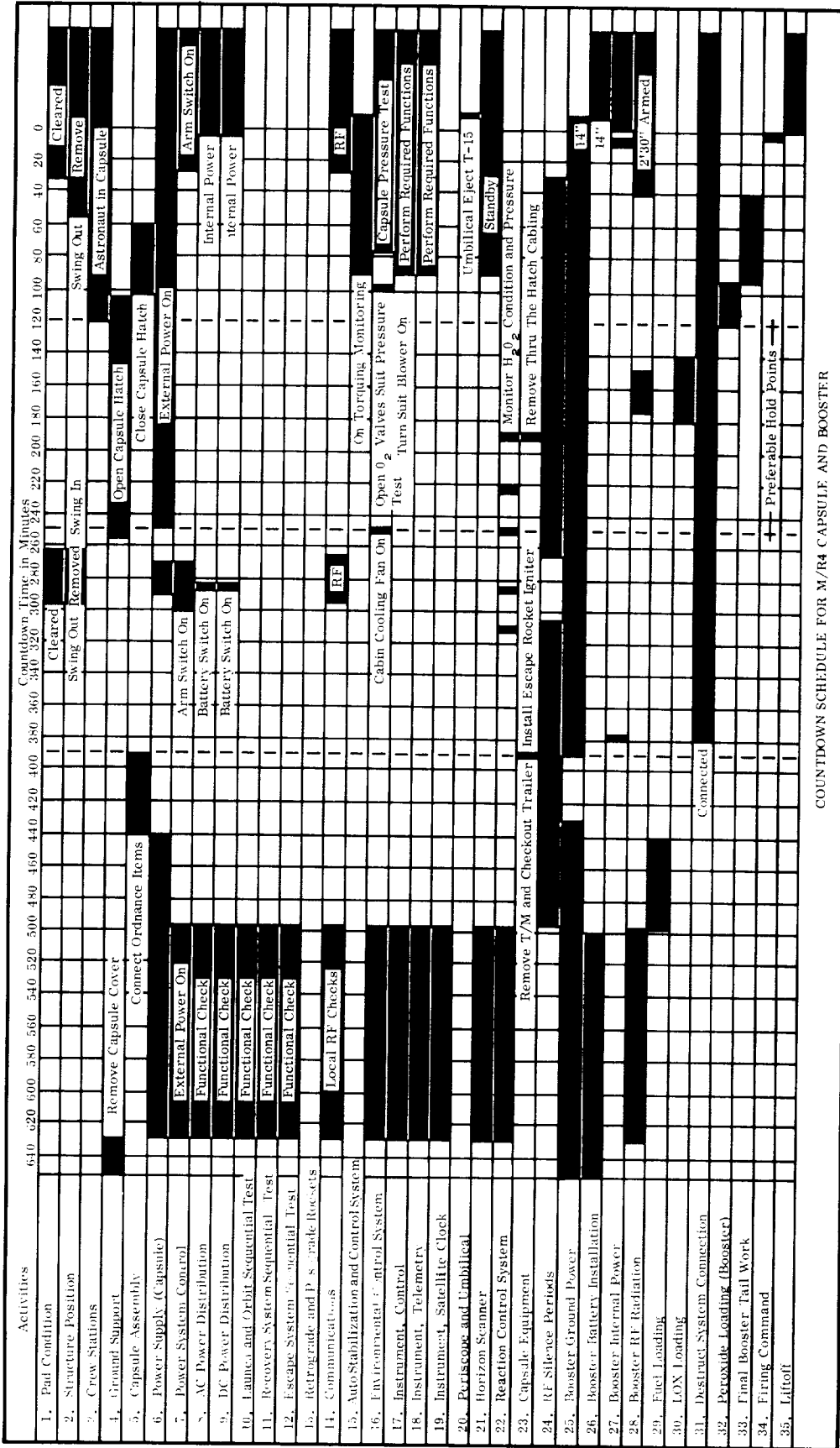

COUNTDOWN SCHEDULE FOR M/R4 CAPSULE AND BOOSTER

Figure 7-3. Bar Chart on Vehicle Countdown Status

Part I - Launch Countdown

- T-640
1. RANGE Verify complex is on critical power.
 2. PAD-M Open instrument compartment and aft section doors.
 3. BH-CAP and PAD-CAP Capsule personnel man appointed stations.
 4. PAD-E Deliver, install, and safety wire booster batteries (except control battery).
 5. M Block booster abort On.
 6. BH After roger from PAD-E apply booster power (prelaunch).
 7. GEN Adjust generator voltages to flight battery voltage data.
 8. PAD-M Remove the following covers and sealing tapes:
 - a. LOX tank vent valve.
 - b. H₂O₂ tank vent valve and overflow assembly. (Replace after components test.)
 - c. LOX pump seal drain.
 - d. Steam seal drain. (Replace after components test.)
 - e. Alcohol pump seal drain.
 - f. Alcohol vent valve.
 - g. LOX replenish vent cap.
 - h. Check annin valve.
 - i. Leave shelter ring On with sides Off.
 9. RANGE RF clearance for DOVAP frequencies.
 10. PAD-E and G Check LEV-3 pots (perform work during RF silence period).
 11. PAD-CAP Remove capsule covers and open for work.
 12. I Ground inverter On.
 13. I Booster inverter On.
 14. M Booster measuring voltage On.
 15. MEAS Warmup blockhouse measuring and recording equipment.
 16. MEAS Calibrate all recorders and make final checks.

Part I - Launch Countdown (Cont.)

T-640 (Cont.)	17. AB and RF	Warmup telemeter ground stations.
	18. PAD-M	Remove pins from capsule retaining ring retaining devices.
	19. PAD-E	Connect over-all test cable for control battery substitute.
T-635	1. BH-CAP and PAD-CAP	Communication check. (Hardwire only.)
	2. BH-CAP and PAD-CAP	Prepare all capsule subsystems for test.
	3. RF	Proceed with DOVAP tuneup checks. (Vehicle transponder may be used anytime prior to T-410.)
T-625	1. PAD-M	Fill booster spheres to approximately 1500 psi.
	2. PAD-M	Set up control pressures required for power plant components test (including cooling system and topping system).
	3. PAD-M&P	Perform components test according to procedure.
	4. PS	Check liftoff and camera start circuits as required by AMR.
	5. SEQ	Check blockhouse sequence recorders.
	6. PAD-E	Check azimuth alignment of LEV-3 (to be given a final launch check at T-130).
	7. RANGE	RF clearance for all capsule RF equipment: Telemeter HF Recovery S-band beacon UHF Recovery C-band beacon Command
	8. PAD-CAP and BH-CAP	Apply capsule power.
	9. PAD-CAP and BH-CAP	Begin systems test.
	10. RANGE	RF clearance for all booster RF equipment: Telemeter 230.4 Mc (U) AZUSA 5000 Mc (U)
	11. RF and AB	Tune booster telemetry for flight.
T-620	1. PAD-MEAS and PAD-M	Move measuring trailer to adjacent Complex 26 and stow for launch.

Part I - Launch Countdown (Cont.)

T-620 (Cont.)	2.	PAD-M	Ready water lead filling equipment after components test.
	3.	P and PAD-M	Load water.
	4.	PAD-M	Drain 680 cc water.
	5.	PAD-M	Remove tail weather shelter.
T-610	1.	PAD-M	Install fuel overflow line after verifying fuel vent is open.
T-605	1.	C	Control voltage On.
	2.	G	Bring LEV-3 gyros On for warmup prior to flight integrator setting and attitude abort checks.
	3.	RANGE	Standby for S- and C-band radar beacon checks. S- and C-band radars away from PAD.
T-600	1.	BH-CAP	C- and S-band radar beacon On.
	2.	RANGE	Readout C- and S-band radar beacons for qualified Go.
	3.	GEN	Check voltage clear after battery installation.
T-580	1.	TC	Reset TC panel.
	2.	M	Step dummy S&A block to arm and safe.
T-540	1.	PAD-M	Verify control pressure removed from capsule mast release valve. Do not apply pressure until cleared with test supervisor. Leave hand vent valve open.
	2.	P	Verify Cap Mast 750 (light Off).
T-530	1.	RANGE	Standby for initial command control checks.
	2.	PAD-E	Double check that Dummy destruct block is connected and verify.
	3.	RANGE	Prepare AZUSA ground station for range check.
	4.	PAD-CAP	Verify shorting plug in escape tower.

Part I - Launch Countdown (Cont.)

T-530 (Cont.)	5.	PAD-E	Remove fuses in booster tail plug and booster boom plug for hardwire abort (Fuse box No. 5, Red fuses 24 and 25; Fuse box No. 2, Green fuses 33 and 34).
	6.	PAD-E	Remove TBI fuses 1, 2, and 3.
	7.	PAD-E	Install Jumper E5 - E6.
T-520	1.	PAD-M	Move fuel (alcohol) trailer into fueling position.
	2.	PAD-M	Turn On yellow warning light.
	3.	M	AZUSA blower On.
	4.	M	AZUSA On.
	5.	RANGE	Check booster AZUSA transponder with range station.
	6.	NOTE	<u>Refer to special sequence test procedures.</u>
T-515	1.	RANGE	Roger AZUSA transponder check.
	2.	M	AZUSA Off.
	3.	M	AZUSA blower Off.
	4.	PAD-M	Remove caps from instrument compartment pressurizing switch and pressurizing valve.
T-500	1.	ALL BOOSTER STATIONS	Standby for booster power transfer test sequence.
	2.	PAD-PAA	Top off 5000 psi GN ₂ batteries if required.
	3.	PAD-E	Verify all flight batteries are installed and secured (except control battery).
	4.	PAD-M	Make final vehicle plumbing checks prior to fuel loading.
T-497	1.	RF	Verify DOVAP reference transmitter On.
	2.	RF	Verify DOVAP test transmitter Off.
T-495	1.	G	Verify Gyro system ready.
	2.	M	Command receiver No. 1 On.
	3.	M	Command receiver No. 2 On.
	4.	M	Telemeter On.
	5.	M	Calibrator On.
	6.	C	Control computer On.

Part I - Launch Countdown (Cont.)

T-495	7.	C	Program device On.
(Cont.)	8.	P	Verify autopilot ok light On.
	9.	TC	Announce warning of instrument compartment pressurizing valve operation during power transfer.
	10.	PAD-M	Monitor instrument compartment pressurizing.
	11.	GEN	Over-all test power On.
	12.	SEQ	Sequence and E&I recorders to minute speed.
	13.	SEQ	Time pulse On.
	14.	M	DOVAP On.
	15.	M	AZUSA blower On.
	16.	M	AZUSA On.
	17.	RF	Telemeter recording On (LOD only).
	18.	C	Rudder drive On.
	19.	C	Verify servo voltage ok (light On).
	20.	P	Verify voltages ok (light On).
	21.	AXN	Power transfer test On and Off (momentarily).
	22.	SEQ	Record all battery bus voltages.
	23.	G	Simultaneous command On and Off.
	24.	L	Network roger of satisfactory power transfer.
	25.	AXN	Emergency booster power Off (verify).
	26.	C	Rudder drive Off.
	27.	RF	Telemeter recording Off (LOD only).
	28.	M	Secure all RF systems.
	29.	SEQ	Secure all recorders.
	30.	C	Control computer Off.
	31.	PD	Check program device flight tape.
	32.	G	Torque each LEV-3 gyro \pm until abort is indicated by TC.
	33.	G and PAD-E	Calibrate integrator cutoff signal.
T-490	1	P	Weight reading prior to fuel loading (clear vehicle when announcement is made and verify to TC).
	2.	MEAS	Monitor fuel tank pressure.

Part I - Launch Countdown (Cont.)

- | | | | | |
|------------------|-------|--------------|---|---|
| T-490
(Cont.) | 3. | P and PAD-M | Start fuel loading. | |
| | 4. | PAD-M | Fill igniter tank. | |
| | 5. | PAD-M | Check for fuel leakage in tail. | |
| | 6. | PAD-M | Torque main LOX bolts. | |
| | 7. | CTC | Verify spike and ballast on fourth platform. | |
| | 8. | PAD-M | Watch fuel vent for overflow. | |
| | T-450 | 1. | CTC | Roger completion of capsule system tests. |
| | | 2. | CTC | Roger removal of test cables. |
| 3. | | PAD-CAP | Remove all capsule test cables (except shorting plug). | |
| 4. | | G | Secure LEV-3 gyros. | |
| 5. | | C | Control voltage Off. | |
| 6. | | CTC and PS | Arm squib bus and begin no voltage checks. | |
| T-440 | 1. | P and PAD-M | Finish fuel loading. | |
| | 2. | PAD-M | Dip stick fuel to determine ullage. | |
| | 3. | P | Weight reading after fuel loading (clear vehicle when announcement is made and verify to TC). | |
| | 4. | CTC and PS | Disarm squib bus after no voltage checks. | |
| | 5. | BH | Establish vehicle RF silence. | |
| | 6. | M | RF Silence Switch On. | |
| | 7. | ANNOUNCEMENT | All personnel not having specific vehicle preparation activities clear service structure for capsule ordnance connection. | |
| | 8. | CTC | Remove capsule power. | |
| | 9. | PAD-CAP | Remove shorting plug and connect all ordnance except escape rocket. | |
| | 10. | PAD-M | Remove fuel trailer. | |
| T-420 | 1. | PAD-M | Adjust TRMV based on trailer alcohol temperature. | |
| | 2. | PAD-M | Safety wire TRMV. | |
| | 3. | BH | Secure booster power. | |
| | 4. | PAD-M | Engine control regulated to zero psig. | |

Part I - Launch Countdown (Cont.)

T-400	1. PAD-M	Install tail weather shelter - pending weather.
	2. PAD-M	Resume LOX pump bearing purge.
	3. PAD-M	Install following covers and sealing tapes: a. LOX tank vent valve. b. H ₂ O ₂ tank vent and overflow assembly. c. Steam seal drain.
	4. PAD-M	Install instrument compartment door O-rings.
	5. PAD-M	Final vacuuming.
T-390	1. END	END operations on first part of split count and secure all systems for standby period. The count will be resumed at T-390 minutes at the predesignated time.

	CAPSULE PERSONNEL	Prepare capsule and ground system for peroxide loading.
	PS and PAD-CAP	Load capsule peroxide and monitor system.

Part II - Launch Countdown

Preparatory steps for picking up the second section of the count:

1. M	Verify RF silence switch On.
2. PAD-CAP	Install, but do not connect, escape rocket igniter (complete 60 minutes before pickup) - area must be cleared.
3. C	Close flight sequence reset switch.
4. BH and PAD-E	Apply booster power.
5. PAD-M	Remove following covers and sealing tapes: a. LOX tank vent valve. b. H ₂ O ₂ tank vent and overflow assembly. c. Steam seal drain. d. Cap Off instrument compartment pressurizing and sensing lines.
6. RANGE	Weather forecast.
7. BH	Verify RF silence.
8. PAD-M	Install destruct block and connect primacord to destruct block (do not connect electrically).

Part II - Launch Countdown (Cont.)

- | | | | |
|-------|-----|----------------------|---|
| | 9. | PAD-M | Connect cable mast No. 1 (booster), eject control line and cable mast No. 2 (capsule), eject control line. |
| | 10. | PAD-CAP | Prepare capsule checkout trailer for moving. |
| | 11. | PAD-CAP | Move capsule checkout trailer to launch. |
| | 12. | RANGE | Standby to resume count. |
| | 13. | PAD-E | Make resistance check of TC igniter. |
| | 14. | PAD-E | Install control battery and safety wire. |
| | 15. | PAD-M | Ready LN ₂ equipment. |
| | 16. | PAD-M | Adjust fin clamps to launch position. |
| T-390 | 1. | PAD-M | Torque turbine. |
| | 2. | CTC | Verify completion of capsule ordnance connection. |
| | 3. | C | Reset flight sequencer. |
| T-385 | 1. | PAD-E | Make final check of 400 cycle inverter frequency and voltage adjustment. |
| | 2. | PAD-E | Make functional check of precooling motor operation. |
| | 3. | M | Safety wire DCR switches. |
| T-380 | 1. | PAD-CAP | Verify helium fill. |
| | 2. | C, GEN | Check voltage clear (control voltage On and Off). |
| | 3. | PAD-M | Load LN ₂ boom tank (booster). |
| | 4. | E | Cooling bypass On (Off after LN ₂ is loaded). |
| | 5. | E | Automatic fill On. |
| | 6. | PAD-M | Torque turbine. |
| | 7. | ANNOUNCEMENT | All personnel not required for operation in the pad area should clear the area for destruct block connection. |
| | 8. | BH | Verify vehicle RF silence. |
| | 9. | PAD-E and PAD-SAFETY | Electrically connect booster cable to destruct block. |
| | 10. | M | Verify destruct safe (light). |
| | 11. | PS | Verify destruct safe (light). |

Part II - Launch Countdown (Cont.)

T-380 (Cont.)	12. PAD-SAFETY	Pull mechanical arming pin on destruct block and clear aft section.
	13. PAD-M	Secure destruct access door for flight.
	14. PAD-E	After no-voltage check remove all structure-utility room over-all test cables.
	15. PAD-M	Secure recovery doors for flight.
T-360	1. PAD-M	Close aft section doors III-IV and I-II.
T-350	1. PAD-M	Close instrument compartment doors (do not secure door III).
	2. E	Normal cooling switch On.
	3. E	Blower On.
	4. MEAS	Monitor instrument compartment temperature.
T-345	1. CTC	Call capsule personnel on station.
	2. PAD-E and PAD-M	Final vertical alignment.
	3. PAD-CAP	Verify disconnect of peroxide lines at capsule and trailer.
T-330	1. PAD-CAP	Capsule interior check.
T-325	1. PAD-PAA	Open platform No. 2.
	2. ANNOUNCEMENT	All operational personnel standby to clear to the blockhouse for RF test; all nonoperational personnel clear the area immediately.
	3. PAD-PAA	Position and secure outrigger (on west side of structure for clearance of power post).
	4. PAD-PAA	Open platform No. 4.
	5. PAD-M	Drop No. 2 mast bunge to ground level.
T-320	1. PAD-M	Close water valves 1, 3, and 4, and open valve 2. Disconnect both safety showers and disconnect water supply line at back of structure.
	2. PS	Establish road blocks and clear area of non-operational personnel for RF test.
	3. PAA-CAP	Install GSE hatch.

Part II - Launch Countdown (Cont.)

- | | | | |
|-------|----|---------------|--|
| T-315 | 1. | PAD-PAA | Open platform No. 3. |
| T-316 | 1. | PAD-M | Disconnect structure pneumatic supply at service pipe 3. |
| | 2. | PAD-PAA | Move service structure to edge of pad. |
| T-305 | 1. | TC | Announce for photo and searchlight crews to clear area. |
| | 2. | TC | Announce for personnel behind blockhouse to come into the blockhouse. |
| T-300 | 1. | C | Control voltage On (voltage clear). |
| | 2. | G | Gyros On. |
| | 3. | G | Erection On. |
| | 4. | RF | Verify DOVAP reference transmitter On. |
| | 5. | PAD-M | Engine control regulator to zero psig. |
| T-298 | 1. | G | Amplifiers On. |
| | 2. | TC | Reset TC panel. |
| T-295 | 1. | ALL PERSONNEL | Clear pad to blockhouse for RF interference test. |
| | 2. | RANGE | Standby for all RF systems check. |
| | 3. | PS | Report to test conductor as soon as area is clear. |
| | 4. | PAD-M | Make remote operational check of service structure from blockhouse. |
| | 5. | M | RF silence Off. |
| | 6. | M | Cut safety wire On DCR switches. |
| | 7. | BH-CAP | Apply capsule power. |
| | 8. | PS | Squib arming switch On (pad cleared position). |
| | 9. | ANNOUNCEMENT | Caution all personnel, capsule abort system arming will be accomplished.
Station Rogers:
a. Blockhouse abort box (Dr. Debus).
b. MERCURY control center.
c. Capsule control panel.
d. Pad safety.
e. SRO.
f. Flight safety. |

Part II - Launch Countdown (Cont.)

T-295 (Cont.)	10. CTC	Arm the squib bus.
	11. TC	Verify proper arm indications on TC panel.
T-290	1. RANGE	C- and S-band radars On.
	2. BH-CAP	Proceed with all RF components tests.
	3. RANGE	AZUSA ground station reading.
	4. M	AZUSA On.
	5. RANGE	Readout AZUSA and report completion to TC.
	6. RANGE	Command carrier On.
	7. M	Telemeter On.
	8. M	Calibrator On.
	9. C	Control computer On.
	10. M	DOVAP On.
	11. RF	Begin check of DOVAP and Beat-Beat.
T-285	1. BH	Sequence and E-1 recorders to minute speed.
	2. BH	Recorder time pulse On.
	3. M	DCR No. 1 On.
	4. M	DCR No. 2 On (allow at least 30-second warmup).
	5. C	Program device On.
	6. C	Rudder drive On.
	7. C	Verify servo voltage ok (light On).
	8. P	Verify voltage ok (light On).
	9. AXN	Power transfer test On and Off (momentarily).
	10. SEQ	Record all battery voltages.
	11. G	Simultaneous control commands On and Off.
	12. L	Network roger of satisfactory power transfer.
	13. AXN	Emergency booster power Off (verify).
	14. C	Rudder drive Off.
	15. C	Program device Off.
	16. C	Control computer Off.
	17. RANGE	Cutoff command.
	18. RANGE	Destruct command.
	19. RANGE	Switch transmitters.

Part II - Launch Countdown (Cont.)

T-285 (Cont.)	20. RANGE	Cutoff command.
	21. RANGE	Destruct command.
	22. M	DCR No. 1 Off.
	23. M	DCR No. 2 Off.
	24. RANGE	Secure command carrier.
T-280	1. ALL RF MONITORING STATIONS	Report any nonflight tolerable type RF interference to the blockhouse.
	2. M	Secure booster RF equipments as individual systems complete their tests.
T-275	1. TC	Receive status report of all uncompleted RF checks.
T-270	1. TC	Check that all RF equipments have been secured.
	2. CTC	Disarm squib bus.
	3. PS	Open squib arming switch (pad <u>Not</u> cleared position).
	4. M	Safety wire DCR switches.
	5. ANNOUNCEMENT	Capsule abort system disarmed.
	6. ANNOUNCEMENT	Operational personnel return to vehicle after power is removed from capsule.
	7. G	Secure gyros.
T-265	1. PAD-M	Engine control regulator to 605 psig.
	2. PAD-PAA	Move service structure around vehicle.
	3. TC	Establish complex and vehicle RF silence.
	4. M	RF silence switch On.
	5. PAD-CAP	Capsule personnel return to structure.
	6. E	Instrument compartment cooling Off.
	7. E	Bypass On, blower Off.
	8. MEAS	Monitor instrument compartment temperature.
	9. PAD-M	Reconnect water supply line at back of structure.
	10. PAD-M	Reconnect safety shower on west side.
	11. PAD-M	Open water valves 1 and 4.
	12. PAD-M	Reconnect structure pneumatic supply.

Part II - Launch Countdown (Cont.)

T-260	1. PAD-PAA	Close platform 2, 3, and 4.
	2. PAD-CAP	Reconnect capsule peroxide lines to capsule and trailer.
T-255	1. PAD-CAP	Open capsule door.
T-250	1. PAD-CAP	Switch change and power up.
	2. PAD-M	Open instrument compartment door III (when internal temperature reaches near ambient).
	3. PAD-M	Apply pressure to booster and capsule masts.
	4. P	Verify mast pressures.
T-245	1. PAD-CAP	Begin control system nozzle static firing.
T-200	1. PAD-M	Bring LOX trailers into position and connect.
	2. PAD-M	Bring tail heater into position.
	3. PAD-M	Install LOX vent pipe.
	4. PAD-M	Remove fuel flex overflow line.
	5. PAD-PAA	Open platform 1.
	6. PAD-M	Connect fuel bubbling and start flow.
	7. PAD-M	Make final torque check on LOX manhole bolts.
	8. MEAS	Last minute checks of blockhouse measuring system.
	9. PAD-MEAS	Check that all hand valves on calibration panel are in proper position for firing and secure.
	10. PAD-M	Locate LOX topping trailer.
	11. PAD-M	Connect electrical cables to LOX topping trailer.
	12. PAD-M	Remove plug-in steam exhaust.
	13. PAD-M	Remove LOX pump bearing purge.
	14. PAD-M	Small heater on alcohol manifold.
T-190	1. TC	Launch weather decision prior to LOX loading.
T-180	1. P	Weight measurement prior to LOX and LN ₂ loading (clear vehicle when announcement is made to TC).

Part II - Launch Countdown (Cont.)

T-180 (Cont.)	2.	P	LOX valve heater On.
	3.	PAD-M	Start LOX precooling and loading sequence.
	4.	MEAS	Monitor LOX tank pressure.
T-165	1.	CTC	Verify astronaut has left Hangar S.
T-145	1.	P and PAD-M	End LOX tanking.
	2.	P	Weight measurement after LOX tanking.
	3.	P	LOX topping to automatic.
T-140	1.	PAD-CAP	Verify astronaut arrival at pad.
	2.	PAD-CAP	Terminate static firing of peroxide nozzles.
	3.	PAD-CAP	Capsule switch check.
T-135	1.	PAD-PAA	Remove LOX trailers.
	2.	PAD-M	Tail heater On.
	3.	PAD-M	Install sheet metal cover on LOX manhole.
	4.	PAD-E	Prepare LEV-3 equipment for final azimuth check.
	5.	PAD-M	Move booster H ₂ O ₂ truck into position.
T-130	1.	PAD-CAP	Pre-purge suit circuit.
	2.	PAD-M	Install thrust chamber igniter. (Do not connect electrically.)
	3.	PAD-E and PAD-M	Perform launch azimuth check.
T-125	1.	TC	Ascertain that all vehicle systems are Go and all preparations are on schedule. If affirmative, proceed with astronaut installation. If negative, a hold should be absorbed at this time prior to astronaut installation.
T-123	1.	CTC	Proceed with astronaut insertion.
T-120	1.	P	Turn H ₂ O ₂ heaters On.
	2.	MEAS	Monitor H ₂ O ₂ tank temperature (redline values: below 70°F, above 90°F).
	3.	PAD-M	Check operation of H ₂ O ₂ heaters (booster).
	4.	PAD-M	Start booster H ₂ O ₂ loading (booster).
T-115	1.	PAD-CAP	Suit purge.

Part II - Launch Countdown (Cont.)

T-105	1. PAD-CAP	Suit pressure check.
T-100	1. PAD-M and P	Check LOX topping computer operation.
	2. PAD-M	Verify No. 1 mast eject line connected.
	3. PAD-M	Close last instrument compartment door and secure for flight (after LEV-3 azimuth check).
	4. PAD-E, PAD-M, and M	Instrument compartment cooling On when last door is in place.
	5. E	Normal cooling switch On.
	6. E	Blower On.
	7. MEAS	Monitor instrument compartment temperature.
	8. PAD-M	End H ₂ O ₂ loading.
T-95	1. ANNOUNCEMENT	All nonoperational personnel clear the area.
	2. PAD-M	Clip safety wire from No. 2 mast release.
	3. PAD-M	Adjust and connect capsule umbilical lanyard.
	4. PAD-M	Make gas evolution check on H ₂ O ₂ system.
	5. PAD-CAP	Harness and cabin inspection.
T-90	1. PAD-M	Move LOD H ₂ O ₂ truck out of immediate area.
	2. PAD-M	Verify No. 2 mast eject control line connected.
	3. PAD-CAP	Install capsule hatch.
T-85	1. PAD-PAA	Open platform 2.
	2. PAD-M	Close water valves 1 and 2 and open 3.
	3. PAD-M	Disconnect safety shower and stow for launch.
	4. PAD-M	Disconnect water supply line at back of structure and secure.
	5. PAD-CAP	Capsule purge.
	6. PAD-E	Check mainstage stick (short momentarily at pad).
T-80	1. PAD-M	Secure drain screw in combustion chamber.
	2. PAD-M	Install ignition sensing stick and resistance check (do not connect).
	3. PAD-M	Torque turbine.
	4. PAD-M	Remove fueling scaffold.

Part II - Launch Countdown (Cont.)

T-80 (Cont.)	5.	PAD-M	Check "check valve" operation in pneumatic systems.
	6.	PAD-E	Open two lids on trench near blockhouse and install safety ropes.
	7.	PAD-PAA	Open CO ₂ valve in utility room.
	8.	PAD-PAA	Verify platform 1 open.
	9.	PAD-M	Move spare parts trailer.
	10.	PAD-CAP	Gas sampling.
	11.	PAD-CAP	Move transfer van to launch position.
T-75	1.	PAD-CAP	Capsule pressure check.
T-70	1.	PAD-M	Make final check of engine control pressure regulator and secure for launch (redline 655 psig maximum, 585 psig minimum).
T-65	1.	PAD-M and E	Turn on P _c switch heaters and transducer heater and confirm operation.
	2.	PAD-PAA	Open platform 4.
T-60	1.	PAD-PAA	Open platform 3.
	2.	PAD-M	Disconnect and secure structure pneumatic supply.
	3.	TC	Obtain clearance from all stations to remove structure to edge of pad.
	4.	PAD-PAA	PAA high pressure personnel in phone circuit for setting up of high pressure system for tail purge.
	5.	PS	Check hold fire and first motion circuitry.
	6.	C	Control voltage On.
	7.	G	Gyros On.
	8.	G	Erection On.
	9.	PAD-CAP	Clear service structure.
	10.	PAD-M	Transfer LN ₂ trailers.
T-57	1.	G	Amplifier On.
	2.	TC	Reset TC panel if required.
T-55	1.	PAD-M	Set up red and blue high pressure storage systems for launch.

Part II - Launch Countdown (Cont.)

- | | | | |
|-----------------|------|---------|---|
| T-55
(Cont.) | 2. | PAD-M | Set up ground regulator to 3000 psig for tail purge. |
| | 3. | PAD-PAA | Move structure to edge of pad and ready remote controls. |
| | 4. | PAD-M | Close tails spheres bypass hand valve. |
| | 5. | PAD-M | Set up 3100 psig to valve box. |
| | 6. | PAD-M | Set ignition regulator to psig. |
| | 7. | PAD-M | Open igniter bottle pressurizing hand valve. |
| | 8. | PAD-M | Torque turbine. |
| | 9. | PAD-M | Monitor remote operation of cherry-picker before placement next to capsule. |
| | 10. | CP | Position cherry-picker for emergency egress operation and station operator in blockhouse. |
| | T-50 | 1. | PAD-M |
| 2. | | PAD-M | Connect ignition sensing stick to valve box. |
| 3. | | C | Rudder drive On and Off for control check. |
| 4. | | M-113 | Verify the M-113 emergency egress vehicle is on station. |
| T-45 | 1. | PAD-M | Remove tail heater and secure for launch. |
| | 2. | PAD-M | Close tail doors I-II. |
| | 3. | PAD-M | Move LOD shop truck to launch location. |
| | 4. | PAD-M | Connect capsule mast bunge cord (G: Observe phi pitch meter for amount of disturbance - missile over 1). |
| | 5. | PAD-M | Check that capsule mast 750 supply hand valve is full open. Check that compartment mast 750 supply hand valve is full open. |
| | 6. | PAD-M | Make last check of cable mast supply ground regulator. |
| | 7. | PAD-CAP | Clear utility room. |
| T-40 | 1. | PAD-M | Check only the following hand valves in the valve box are open:
a. Regulator inlet.
b. Igniter bottle pressurizing. |
| | 2. | PAD-M | Remove last scaffold. |

Part II - Launch Countdown (Cont.)

T-40 (Cont.)	3.	PAD-SAFETY	Remove all nonauthorized vehicles from rear of blockhouse.
	4.	PAD-E	TC igniter cable check.
	5.	PAD-M	Disconnect fuel bubbling and install cap on coupling.
	6.	PAD-M	Close tail door III-IV.
T-35	1.	ANNOUNCEMENT	All personnel not stationed in the blockhouse for launch, clear the area to launch location.
	2.	CTC	All capsule systems go verification.
	3.	PAD-M	Connect igniter squib to valve box.
	4.	PAD-M	Close utility room door and secure for flight.
T-33	1.	PAD - ALL PERSONNEL	Clear area to blockhouse.
T-30'	1.	PS	Verify complex area is clear and RF silence may be lifted.
	2.	M	RF silence switch Off.
	3.	MEAS	Check that all brown recorders are On.
	4.	C	Control computers On.
	5.	CTC	Functional check of hold fire.
	6.	M	DOVAP On.
T-29	1.	RANGE	Standby for radar beacon checks C- and S-band radars away from pad.
T-25	1.	CTC	All RF systems On.
	2.	CTC	C- and S-band beacons On.
	3.	PS	Squib arming switch On (when complex area is Safe).
	4.	ANNOUNCEMENT	Capsule abort system is to be armed.
	5.	RF	DCR monitor receiver On.
	6.	RANGE	Command carrier On.
T-24	1.	M	Telemeter On.
	2.	M	Calibrator On.
T-22	1.	M	Recorder transfer On and Off as request for telemetry check.
	2.	CTC	Arm capsule squib bus.

Part II - Launch Countdown (Cont.)

T-22 (Cont.)	3.	CTC	Verify abort disarm switch in manual position.
	4.	ANNOUNCEMENT	Capsule abort system armed.
	5.	ABTL	Verify abort armed (light On).
T-20	1.	P	Tail purge On.
	2.	M	AZUSA On.
T-18	1.	RANGE	AMR telemeter check.
	2.	AB	LOD telemeter check.
T-16	1.	C	Meter range On.
	2.	C	Rudder drive On.
	3.		Simultaneous command On and Off.
	4.	C	Rudder drive Off.
T-15	1.	TC	Obtain Dr. Debus' ok for launch.
	2.	CTC	Begin transfer of capsule to internal power.
	3.	M	Cut safety wire on DCR switches.
T-14	1.	M	Preflight calibrator to 0 percent.
	2.	M	Calibrator Off.
T-12	1.	M	Preflight calibrator to 100 percent.
T-10	1.	P	Pressurize missile spheres to 3000 psi.
	2.	M	Calibrator On.
	3.	C	Rudder drive On and Off.
	4.	M	Preflight calibrator Off.
	5.	MEAS	Ground measuring voltage minus in block-house momentarily.
T-9	1.	M	Preflight calibrator Off (left side).
	2.	M	Calibrator Off.
	3.	MEAS	Verify 100 cps oscillator is set up.
T-8'45"	1.	RANGE	Telemeter recording On.
	2.	AB	Telemeter recording On.
	3.	M	Preflight calibrations as follows: From Off to oscillator and pause 5 second CEC recorders On. In 1 second intervals oscillator

Part II - Launch Countdown (Cont.)

T-8'45'' (Cont.)		to 0 to 10 to 20 to 30 to 40 to 50 to 60 to 70 to 80 to 90 to 100 to 0 percent.
	4. M	Calibrator On.
	5. M	Forced calibration On and Off.
	6. RANGE	Telemeter recording Off.
	7. AB	Telemeter recording Off.
	8. M	Preflight calibrator Off.
	9. BH-PAA	Remotely move structure to launch position.
T-7	1. M	Command receiver No. 1 On.
	2. M	Command receiver No. 2 On.
T-6	1. P	Check that LOX topping is on schedule.
	2. SEQ	Sequence and E&I recorders minute speed.
	3. SEQ	Time pulse On.
	4. C	Program device On.
	5. GEN	Check voltage adjustments.
T-5	1. C	Rudder drive On (prep complete).
	2. P	Verify voltage ok (light On).
	3. AXN	Power transfer test switch On momentarily.
	4. G	Simultaneous commands On and Off.
	5. RANGE	Cutoff command.
	6. L	Network roger satisfactory power transfer.
	7. AXN	Emergency booster power Off.
	8. C	Rudder drive Off.
	9. G	Check LEV-3 gyro position indications.
	10. C&G	Clear signal from control and gyro panel.
T-4	1. TC	Check stations for proper indications.
		a. Power panel (P).
		b. Measuring panel (M).
		c. Autopilot rack (G&C).
		d. Capsule test conductor (all capsule indications).
		e. Blockhouse measuring (MEAS).
		f. Sequence recorders (SEQ).
		g. Telemeter station Hangar D (AB).

Part II - Launch Countdown (Cont.)

T-4 (Cont.)		h. Pad safety (PS).
		i. BH-PAA (service structure secure).
		j. Aeromedical.
T-2'30"	1. P	Selector switch to launch.
	2. M	Arm destruct package.
	3. PS	Note destruct armed and close hold fire.
	4. CTC	Final clearance from capsule.
	5. CP	Remove cherry-picker to launch position.
T-2	1. M	Block booster abort Off.
	2. C	Rudder drive On.
	3. P	Verify ready to fire (indication).
	4. G	Simultaneous commands.
	5. RANGE	Telemeter recording On.
	6. BH-CAP	Proceed with telemeter preflight calibrations.
T-60"	1. RANGE	Give mark to range at 60 seconds.
	2. P	LOX topping Off.
	3. AB	LOD telemeter recording On.
T-50"	1. BH-CAP	Freon flow cutoff.
T-47"	1. SEQ	Sequence recorders fast speed.
T-35"	1. P	Firing command.
	2. ALL STATIONS	Verify automatic sequence as major items occur.
	3. CTC	Announce "Capsule umbilical dropped."
	4. CTC	Announce "Periscope door closed."
	5. P	Announce "Vent valves closed."
	6. P	Announce "Fuel tank pressurized."
	7. MEAS	Announce "LOX tank pressurizing."
	8. P	Announce "LOX tank pressurized."
(T-14")	9. GEN	Announce "Missile power."
	10. P	Announce "Boom drop."
	11. P	Announce "Ignition."
	12. P	Announce "Mainstage."
T-0	1. P	Announce "Liftoff."

Part II - Launch Countdown (Cont.)

- | | | |
|-----|----------|---|
| T+0 | 1. RANGE | Liftoff. |
| | 2. RANGE | Clock start. |
| | 3. RANGE | Call out time in 10 second increments until T+180, in 30 second increments until termination. |
| | 4. BH | All personnel except Launch Director remain in place during flight. |
| T+5 | 1. BH | Sequence recorders Slow. |

TEST TERMINATION

- | | |
|------------|--|
| 1. PAD-M | Secure high pressure GN ₂ . |
| 2. PAD-PAA | Close CO ₂ bottles. |
| 3. P | Vent CO ₂ line. |
| 4. PAD-M | Secure LOX topping and LN ₂ trailers. |
| 5. GEN | Secure ground generators. |

Explanation of code used in countdown.

- | | |
|---------|---|
| AB | Telemeter station hangar D (booster) |
| ABT | Blockhouse abort panel (Dr. Debus' panel) |
| AXN | Auxiliary network panel |
| BH | Blockhouse (miscellaneous operations) |
| BH-CAP | McDonnell, NASA, and Aeromedical |
| BH-PAA | Pan American pad operations |
| C | Control panel |
| CP | Mobile cherry-picker tower |
| CTC | Capsule test conductor |
| E | Environmental control panel (booster) |
| G | Gyro panel |
| GEN | Generator panel |
| I | Inverter panel |
| L | Recorder light panel |
| M | Measuring panel |
| MEAS | Blockhouse measuring (booster) |
| M-113 | Emergency rescue vehicle |
| P | Propulsion panel |
| PAD-CAP | McDonnell and NASA pad capsule operations |

PAD-E	G&C, network pad operations
PAD-M	Fueling, propulsion, mechanical pad operations
PAD-MEAS	Measuring pad operations
PAD-PAA	Pan American pad operations
PAD-SAFETY	Pad safety (PAA) pad operations
PD	Program device rack
PS	Pad safety panel (blockhouse)
RANGE	Items handled through central control to remote range stations
RF	Blockhouse and remote RF system (booster)
SEQ	Blockhouse function recorders (SEQ, voltage, current)
TC	Test conductor panel (vehicle)

7.3 EMERGENCY EGRESS OPERATIONS

7.3.1 ORGANIZATION OF RESPONSIBILITIES

7.3.1.1 General

Responsibility for the protection and safety of personnel on the AMR and surrounding areas was governed by standard pad safety and range safety regulations. The responsibility for the protection, safety, and rescue of the astronaut was vested in NASA.

To provide maximum safety to the astronaut during all phases of the launch and flight, and to cover every conceivable emergency situation, the areas in proximity to the flight path of the vehicle were divided into recovery sectors.

7.3.1.2 Launch Pad Area

This area consisted of all the facilities inside the fence of Complex 56, concerned primarily with providing emergency egress for the astronaut. A Pad Area Rescue Squad (PARS) was organized to accomplish this task. The PARS was responsible to the launch director until liftoff or until capsule separation if an off-the-pad abort occurred. Rescue operations on the pad were conducted under supervision of the launch director, and recovery, if capsule flight occurred, was under the direction of the launch site recovery commander.

7.3.1.3 Launch Site Recovery Area

This area consisted of all the land area from four nautical miles uprange of the pad to 12 nautical miles downrange of the pad along the flight line including the water area immediately offshore of the Cape as well as the Banana River. Responsibility for this area was delegated to the launch site recovery commander.

7.3.1.4 Downrange

Downrange consisted of the range area from approximately 12 nautical miles offshore downrange of the Cape, to the predetermined normal capsule recovery area, with a 24-nautical-mile wide corridor. Responsibility for the operations within this area was delegated to the United States Navy Recovery Task Force Commander.

7.3.2 RESCUE OPERATIONS TIME STUDY

Extensive time studies were made to determine which of the equipment available was best suited for each specific period of time in the countdown. The studies were divided into two major categories: one for the astronaut self-sustaining, and one for the astronaut incapacitated. Figure 7-4 is a compilation of the findings of these studies.

The basic rule predominant in the final selection of the methods employed was that a maximum security be provided for the astronaut with a minimum risk to rescue personnel. Three members of the rescue squad were involved in rescue operations requiring squad access to the capsule.

In Figure 7-4 the heavy bar indicates the time the astronaut would be exposed to a hazardous vehicle, and the shaded bar indicated the total man-seconds all personnel involved in the rescue would be exposed to a potentially hazardous booster. These time studies, therefore, aided in the selection of optimum methods for the guidelines established. Having selected the optimum methods, and considering the status of the vehicle and complex, a set of procedures were devised to cover the general type of major failures that could occur for eight combined vehicle-complex conditions. It was not feasible to preconceive and reduce to writing, rescue procedures for every remotely possible malfunction; therefore, the successful execution of a rescue operation was largely dependent upon the response, skills, and adaptability of the individuals affecting the operations.

EMERGENCY EGRESS TIME STUDY

ASTRONAUT SELF SUSTAINING

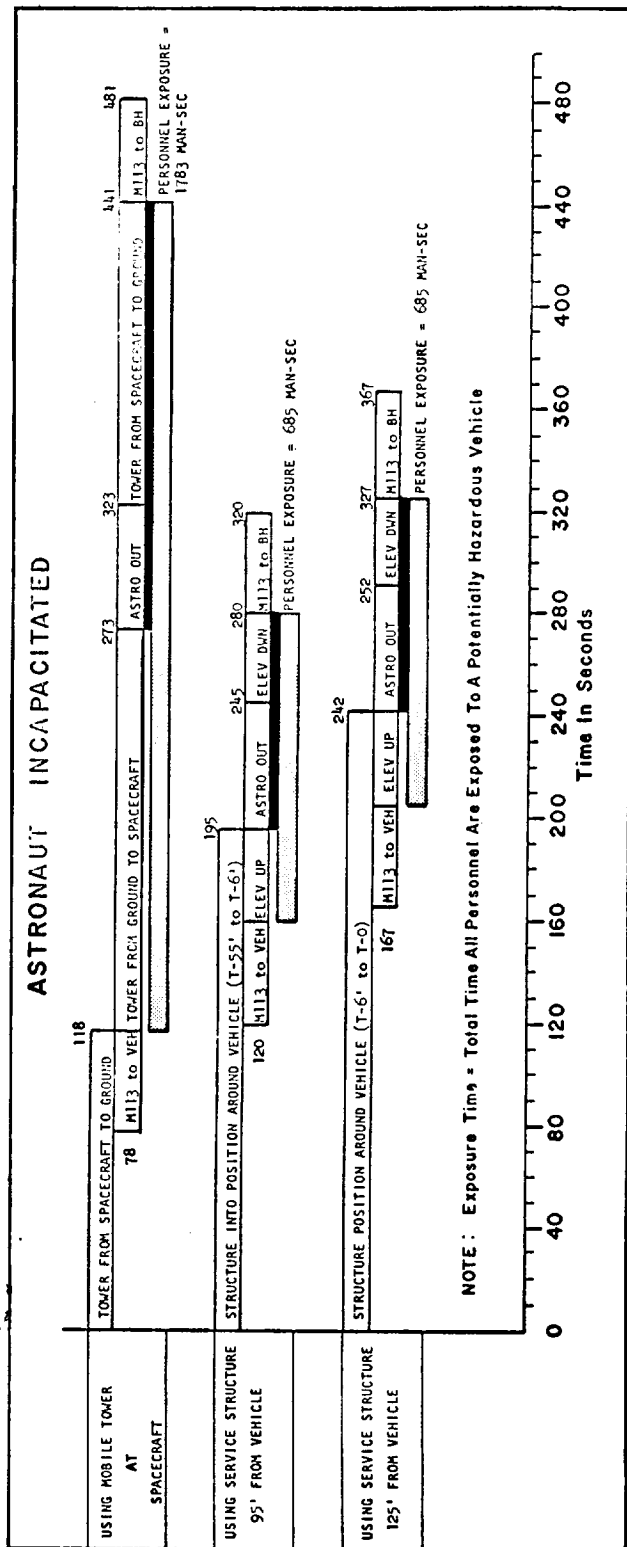
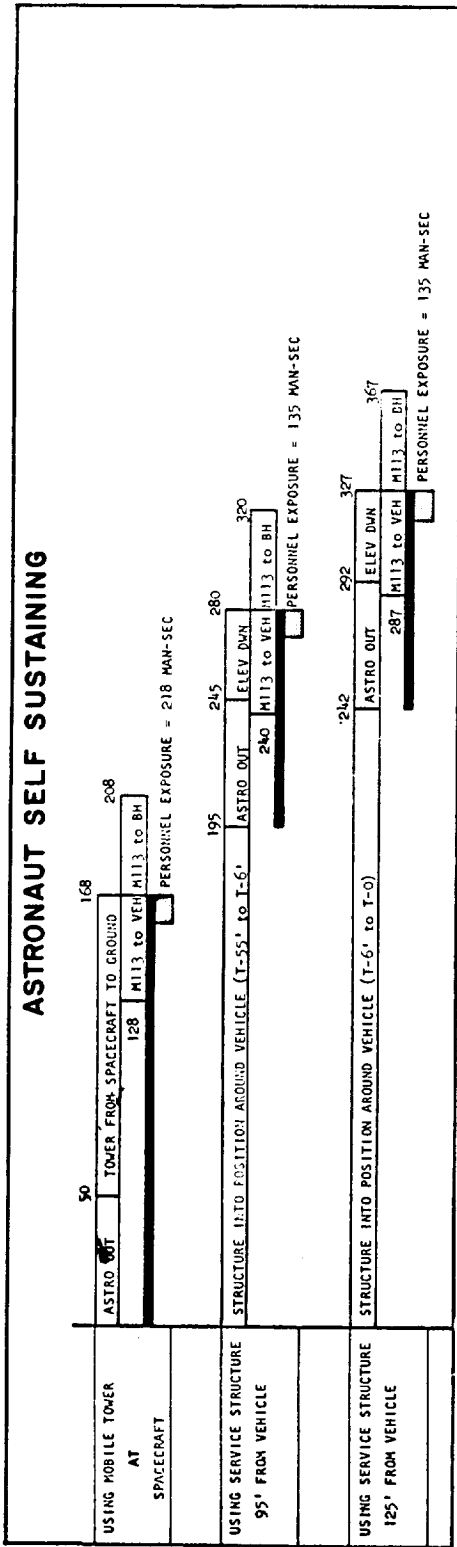

Figure 7-4. Emergency Egress Time Study

7.3.3 EMERGENCY EQUIPMENT

7.3.3.1 Mobile Aerial Tower

The mobile aerial tower, shown in Figure 7-5, was originally intended, by STG, to be used with the MERCURY-ATLAS. Because of desire to gain experience, and since time studies revealed it to be faster than the remote controlled structure under certain conditions, it was selected for egress of the self-sustaining astronaut after the service structure was removed from around the vehicle. The tower, cherry picker, was capable of reaching vertical heights of 125 feet. The tower cab was specially designed to be positioned next to the capsule hatch to provide the astronaut with a means of rapid self-egress, should booster or capsule conditions dictate such action. The tower could be controlled from a position on the ground at the rear of the truck-transporter, from within the tower cab, or could be lowered by remote programmed control from within the blockhouse. Special pushbutton switches which actuated a programmed descent away and down from the MERCURY-REDSTONE vehicle were installed in the tower cab and the blockhouse. The remote control pushbutton switch in the blockhouse was located on the service structure remote control panel. The cab of the mobile tower was positioned next to the capsule hatch when the service structure was removed from the vehicle, and it remained in this position until T-4 minutes of the countdown for emergency use by the astronaut.

7.3.3.2 M-113 Armored Personnel Carrier

The military M-113 armored personnel carrier was selected to provide transportation and limited protection for the PARS. The M-113 is capable of withstanding 12 psi overpressure, and it could provide limited protection against heat if the vehicle had to travel near or through the edge of a fire to reach the capsule. The M-113, a full track vehicle designed for cross country operation, is capable of traveling over the scrub terrain of the Cape at speeds of up to 35 miles per hour. It was specifically modified with the communications and miscellaneous equipment peculiar to these emergency operations listed as follows:

- Communications
 - a. 30.3 mc transmitter and receiver.
 - b. Aeromed net, UHF radio and receiver.
 - c. Missile operational inter-phone system.
 - d. Vehicle crew inter-phone system.
 - e. Public address speaker.



Figure 7-5. Mobile Tower (Cherry Picker)

- Auxiliary Equipment
 - a. Vehicle pusher blade adapter.
 - b. Shepards crook on 25 feet of wire cable.
 - c. Crash helmets with earphones.
 - d. Aluminized two-piece fire suits with boots.
 - e. Scott Air Paks with five-minute bottles.
 - f. Two fire entry suits.
 - g. Special fire axe to provide hook aperture.
 - h. Portable resuscitator.
 - i. Heavy duty manual bolt cutter.

The members of the PARS, stationed in the M-113 armored personnel carrier during the countdown and launch, are listed below. The personnel of this crew were kept at a minimum to reduce the numbers exposed to a potential hazard:

- Vehicle commander.
- Medical doctor.
- Capsule technician.
- Two firemen (one M-113 driver).
- Mobile tower (cherry picker) operator.

In accordance with the egress procedures developed by the egress committee, the PARS was assigned the following functions:

- Perform emergency astronaut egress from the capsule while the booster was still in an erect position on the launch pad.
- Perform emergency recovery/rescue in the event of an off-the-pad abort or some abort condition wherein the capsule landed within the launch complex area.
- Assist, as requested by the launch site recovery commander, in recovery and/or rescue outside the launch complex area.

7.3.3.3 Emergency Equipment Location

The location of the emergency egress equipment, at approximately T-55 minutes, is shown in Figure 7-6. As illustrated, the service structure has been moved back to its launch position; the mobile tower cab has been positioned next to the capsule hatch; and the M-113 personnel carrier is moving in to embark the mobile tower operator

before proceeding to its launch position. The position of all the other emergency equipment, required for rescue and fire fighting for the periods from T-55 minutes to liftoff, is also shown.

7.4 RANGE SAFETY

7.4.1 RANGE SAFETY OFFICER (RSO) OPERATIONS

For ballistic vehicles, such as MERCURY-REDSTONE, the RSO had a plotting board display indicating the real time impact point, which was the point where the vehicle would impact if thrust termination occurred at the time of presentation. The data sources available to the IBM 7090 computer, or "Impact Predictor," were the C-band radars at the Cape, Patrick AFB, GBI, and the AZUSA Mark II at the Cape. The beat-beat system, developed by LOD, measured the phase difference of an airborne CW signal received by two antennas. These phase or beat differences were expressed in terms of the difference of the two slant ranges. Systems with their center line or zero beat line approximately 90 degrees to the flight line yield representations of the program and lateral deviations of the vehicle. These representations were presented on strip chart recorders for the RSO. AMR ELSSE (electronic skyscreen equipment) and NASA Beat-Beat MK II telemetry tracked one each of the vehicle's telemetry transmitters.

To protect life and property from an erratic vehicle, the Range Safety Division (RSD) of AFMTC required each vehicle launched from CCMTA to carry two independent command systems capable of terminating powered flight and/or destroying the vehicle. Two ARW-19 command receivers were carried in the MERCURY-REDSTONE boosters for range safety. Command transmitters were standing by at Cape Central Control, at Cape Command Destruct Transmitter Site, and GBI station 3. For the RSO's surveillance, real-time plotting board displays of the vehicle positions were provided in terms of ground range versus cross range (ground trace), ground range versus altitude (program profile), and altitude versus cross range (lateral profile). The data source for each position plotting board could be switched, during flight if necessary, between C-band and S-band radars on the Cape, and C-band radars at Patrick AFB and GBI in accordance with the prescribed range safety plan.

7.4.2 ABORT CONSIDERATIONS

A three-second period between an abort initiated by range safety cutoff command and fuel dispersion (destruct) command was requested by STG. This three-second period assured that a sufficient separation existed between the spacecraft and exploding

booster. RSD accepted a 105-degree launch azimuth and the requirement for the three-second separation time with the understanding that the destruct corridor would be correspondingly decreased along the southern impact line. RSD concurred in the allocation of abort command responsibility to the blockhouse (to T+8 seconds), the MERCURY Control Center, and the astronaut. RSD requested, however, that a stability analysis be made to ascertain how long the booster would fly if the capsule were aborted in flight. Subsequent agreements resulted in the incorporation of special provisions during the first period of flight wherein an abort command, during the initial 30 seconds of flight, would not cause a booster cutoff command except at the discretion of RSD. This provision assured that if an abort were given for spacecraft reasons a good booster could continue in powered flight to a safe impact area.

7.4.3 LAUNCH AZIMUTH CONSIDERATIONS

The original MERCURY-REDSTONE launch azimuth of 105 degrees was selected on the basis of minimum overland time, adequate distance from downrange islands (including all dispersions), optimum tracking coverage, nonhazardous Cape impact locations, and suitable recovery areas. This selection was also based on analysis of prevailing winds in the launch area and the development of a system of interchangeable escape rockets with different directions of lateral displacement.

While the RSD concurred in a 105-degree launch azimuth, they had originally stated a preference for a flatter trajectory (to reduce time over land) and a 100-degree azimuth; prior to the MERCURY-REDSTONE flight MR-2, LOD, STG, and the RSD agreed to a flatter trajectory (which initiated the tilt program earlier in flight). As a consequence, flights MR-2 and MR-BD were launched on an azimuth of 105 degrees utilizing the flatter trajectory.

In the interval between the MR-BD and MR-3 launches, however, RSD investigated the azimuth problem in further detail and discovered that, except for the early launch phase, a three-sigma right deviation trajectory for flight MR-3 would violate the range safety criteria, as imposed on the radar present-position plot (X-Y plot). Inasmuch as the scheduled launch of MR-3 was too close at hand for an azimuth change, a waiver was requested to allow the three-sigma right deviation trajectory. RSD indicated a willingness to grant the waiver if the launch agency agreed to change the azimuth to 100 degrees for all subsequent MERCURY-REDSTONE launches. STG concurred on this azimuth change for the MR-4 launch.

7.4.4 IMPLEMENTATION

Having established the methods, a set of procedures was prepared. This document was entitled Emergency Handbook for Pad Area Rescue. It was issued prior to the flight of MR-3, recalled and updated, and reissued for the flight of MR-4. The document defined, in sequential steps, the action necessary to cope with a preconceived emergency and identified by title the personnel responsible for each action. In the preparation of these procedures, detailed studies on the booster, the capsule, AMR, and Complex 56 GSE were made by the emergency egress committee. These procedures were subsequently translated into the MERCURY-ATLAS program by changing booster procedures and substituting the egress tower for the mobile serial tower which proved impractical for the MERCURY-ATLAS operation.

7.5 SPECIAL LAUNCH FACILITIES AND DISPLAYS

7.5.1 SERVICE STRUCTURE

7.5.1.1 General

Prior to its use in the MERCURY-REDSTONE Program, the service structure on VLF 56, shown in Figure 7-7, was used for the launching of REDSTONE, JUPITER, and JUPITER-C launch vehicles. In order to accommodate the MERCURY-REDSTONE vehicle, a number of major modifications to the structure were required which are explained in the following paragraphs.

7.5.1.2 White Room

Level three of the service structure was the area utilized for checkout and preparation of the MERCURY capsule. The capsule was mechanically mated to the booster approximately two weeks prior to launch. During this period of checkout and preparation, it was necessary to remove the capsule hatch for many of the checks. In reviewing the onboard capsule films taken on the first two successful unmanned flights (MR-1A and MR-2), it was discovered that a considerable amount of dust and other debris, apparently carried into the capsule during preflight checks, was floating about inside the capsule during the period of weightlessness. In February 1961, LOD was requested to explore the possibility of enclosing and air conditioning the capsule on level three of the service structure. Design requirements were as follows:

- Panels withstand 55 mile per hour winds.
- Panels be readily removable for winds exceeding 55 miles per hour.

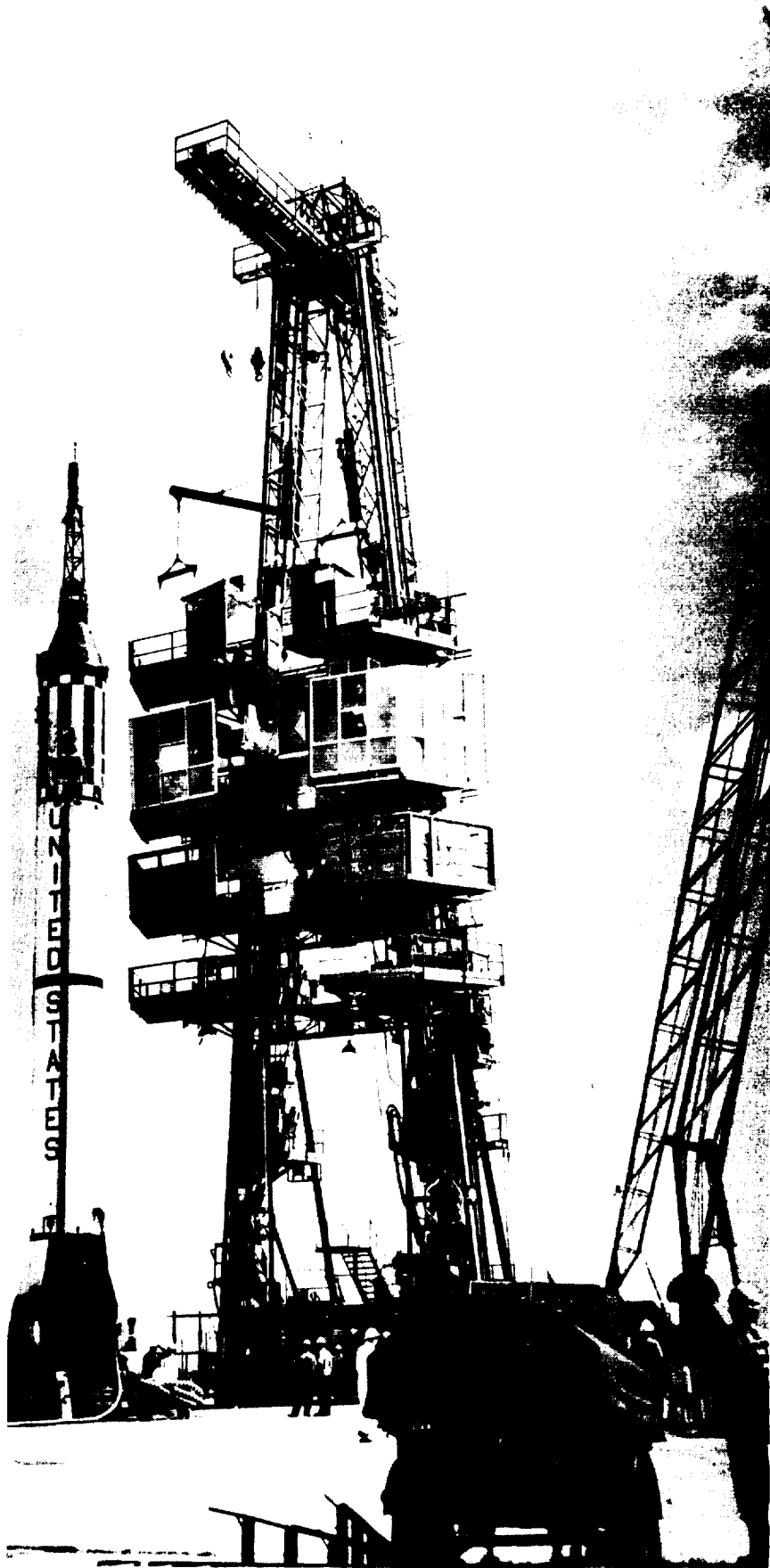

Figure 7-7. Service Structure, Pad 5, VLF 56, Cape Canaveral

- Special hospital-type floor coverings.
- Air conditioning system to provide a 20 percent safety factor for both temperature and humidity control.
- A 20 by 50-inch camera platform with live load capacity of 350 pounds.

Since this project was carried out on a crash basis, it is obvious that no formal design procedures were possible. The enclosure was consequently designed and constructed on a day-by-day basis on the site in order to meet the required date for MR-3. The room proved effective and satisfactory in the flights of MR-3 and MR-4 and is shown in Figure 7-8.

7.5.1.3 Escape Rocket Flame Deflector

A solid fuel escape rocket and tower were attached to the capsule. This rocket was to be used to separate the capsule from the booster if a catastrophic condition had occurred. The presence of this escape rocket above the space vehicle created a hazardous condition which would have proved fatal to personnel on the structure if inadvertent ignition had occurred. No explosive train interrupter (safing and arming device) or exploding bridgewire system was incorporated in the escape rocket. In order to eliminate this potential hazard, LOD requested that a flame and blast deflector be provided. Figure 7-9 shows the design of the service structure.

7.5.1.4 Remote Controls

Remote control of the MERCURY-REDSTONE service structure was initially proposed for the purpose of expediting lengthy countdown periods. The installation and operational approval was completed in August 1960. In subsequent discussions concerning emergency egress on the launch pad, it was decided to utilize the remote control provision for emergency purposes. System modifications were required to meet the exacting demands of emergency operation within existing design limits. Additional requirements involving special television camera installations for remote control purposes, a remote open-close control for use by the astronaut and rescue crew for Platform Three, and a backup power source were added. The remote control panel shown in Figure 7-10 was mounted near the pad safety position in the blockhouse. In addition a remote control for lowering the mobile aerial tower was provided. The remote controlled service structure proved very effective in operations. Adaptation of remote controls to support emergency egress procedures were accomplished on a crash basis during the three months and five days interim between the launches of vehicles MR-2 and MR-3 on a time-available, noninterference basis.



Figure 7-8. White Room on Level 3, Service Structure, VLF 56

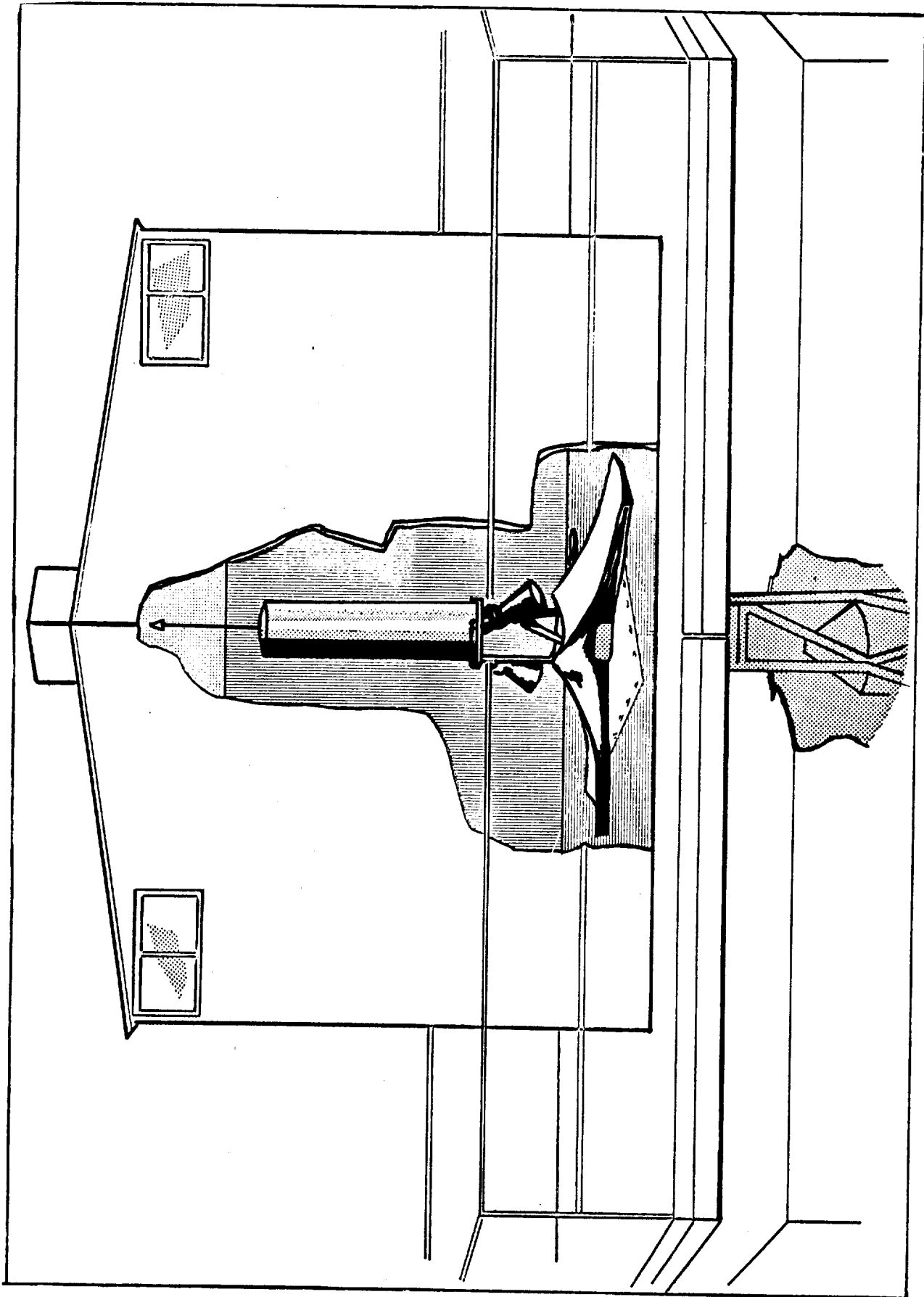

Figure 7-9. Design of Blast Deflector, Service Structure, VLF 56

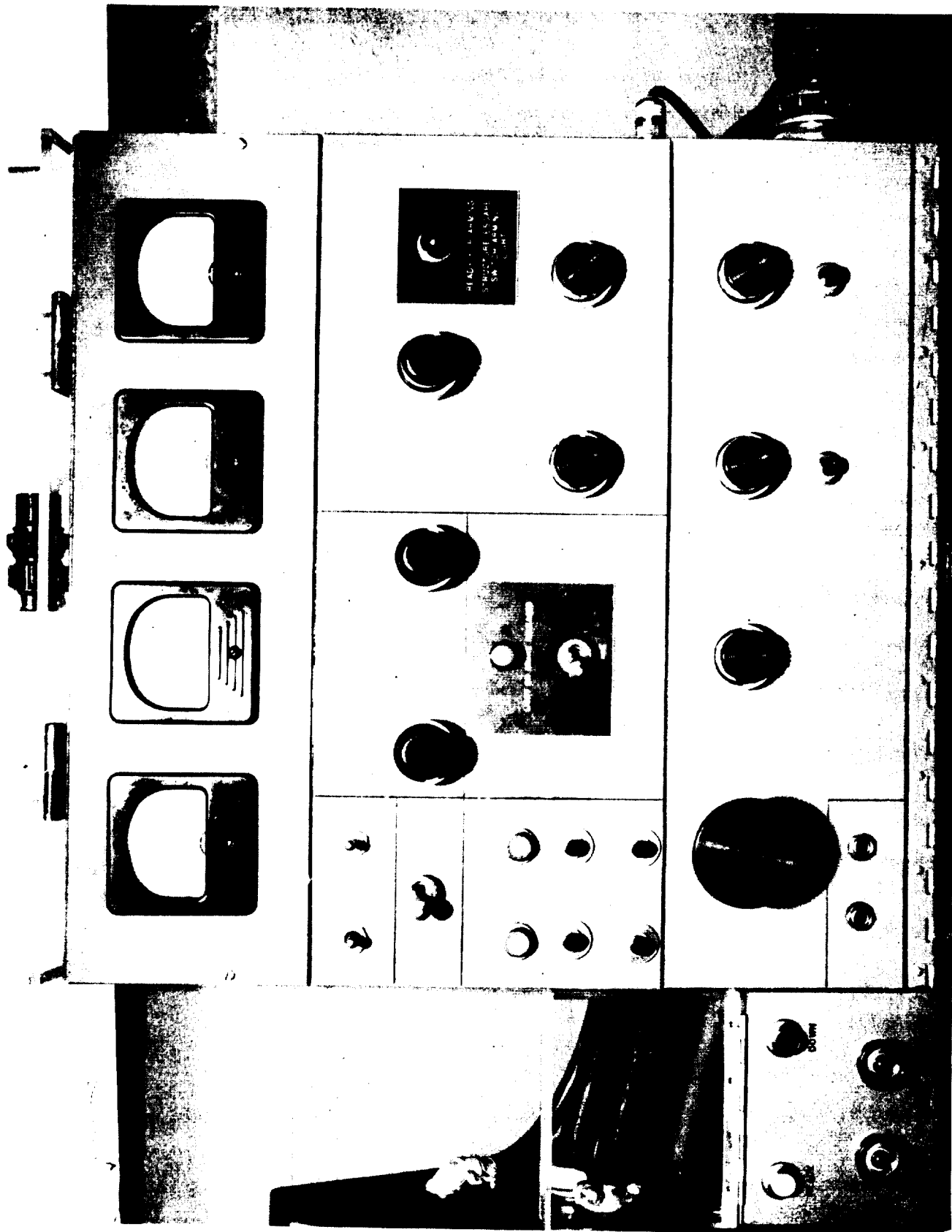

Figure 7-10. Remote Control Panel, Blockhouse 56

7.5.1.5 Television

To provide visual monitoring for remote control by the blockhouse and for information to the MERCURY Control Center, television cameras were mounted in several locations on the structure and around the launch pad area. Two of these cameras were located inside the white room on level three to show capsule operations. The camera located on the northwest side of level three, was mounted so that it could be remotely positioned to look at the MERCURY-REDSTONE vehicle after service structure removal. A third camera was mounted at ground level on the east side of the structure to show service structure movement relative to the launch vehicle. A fourth camera, mounted on top of the blockhouse, presented an over-all view of the launch pad. All of these cameras could be controlled and positioned remotely from within the blockhouse. A fifth camera, positioned to show the DOVAP recorders in the blockhouse, was activated after service structure removal, and was substituted for the number four camera located on top of the blockhouse. The video output of these cameras was also made available to the commercial television networks for use in their nationwide coverage of the manned MR-3 and MR-4 flights at the discretion of the NASA Controller.

7.5.1.6 Auxiliary Platform

It was originally intended that the capsule contractor would provide such necessary scaffolding and access media on levels three and four of the service structure as required. In a meeting on 6 October 1960, of the launch operations committee, STG advised that provisions for access to various levels of the capsule were too restricted and proposed an auxiliary level at the base of the escape tower. This problem was revealed during the first mating of MR-1. An analysis of the problem was made and an auxiliary platform was proposed which would accommodate six personnel and 300 pounds of equipment. The platform would also provide associated electrical interlocks, railings, access ladders, and other equipment. Installation of the platform was satisfactorily completed by 8 December on a priority basis. This platform is shown in the upper section of Figure 7-11.

7.5.1.7 Platform Reinforcement

Platform three was designed for load limits of 10 personnel (2000 pounds) and 500 pounds of equipment. During the first mating of MR-1 at CCMTA, it was observed that these load limits were exceeded and that the platform was being deflected. Investigation revealed that platform loads were approximately 4000 pounds with greater loads to be



Figure 7-11. Auxiliary Platform, White Room, Service Structure, VLF 56

expected during the manned flights. Design of the reinforcement proceeded at an accelerated pace, and installation on the structure was scheduled between flights of MR-2 and MR-BD on a noninterference basis. The installation was completed in February 1961.

7.5.1.8 Miscellaneous Modification Requirements

A number of additional modifications of lesser magnitude, fulfilled on a priority basis, are as follows:

- A special shelter was provided on the fourth service structure level to provide protection of the capsule from the elements and improve working conditions. This entailed rehabilitation and modification of an available shelter.
- A special enclosed cable storage platform was provided for safe and protected storage of the capsule cables.
- A cable boom was provided on the structure to keep cables, used to connect capsule trailers, off the ground and free from potential damage.
- Additional lights were provided in the shelter house and on the structure level to provide adequate illumination for work and for photographic coverage.
- Special handling equipment for the capsule tester was designed and manufactured.
- Cable trays and cable hanging equipment were designed and installed between levels three and four.

7.5.2 GROUND ABORT COMMAND SYSTEM

The mission of the MERCURY-REDSTONE vehicle was such that the circuitry and monitoring panels in the GSE, used for the abort system and booster checkout, required a somewhat different approach from the unmanned missiles. Abort capability, generally, was an integral part of the vehicle systems. The Launch Director could initiate abort by hardwire until liftoff and by radio command until eight seconds after launch. Since the blockhouse had adequate windows from which booster performance could be observed to eight seconds after liftoff, the ground abort command emanated only from the blockhouse during this period. During the subsequent part of the flight, abort command authority was turned over to the MERCURY Control Center.

Redundancy for the abort system required that each hardwire abort line, from the GSE to the vehicle, have the capability to command an abort should the need arise. The MERCURY-REDSTONE vehicle also incorporated a means by which the destruct system could be checked without simulating vehicle liftoff. This was accomplished by adding circuitry and components to the GSE to provide a liftoff signal to the command receivers only.

Abort batteries were incorporated into the ground support equipment to maintain an abort capability by the Launch Director in the event of a launch complex power failure. This was accomplished with relays which would normally be energized but which would de-energize with the loss of power and place the capabilities of receiving abort indications, sounding a buzzer, and retaining the indications when received. This provided a reliable and effective means to monitor, detect, and correct malfunctions and/or improper operation of the abort system.

After liftoff, telemetry data, optional from two ground stations, was transmitted (one via hardwire) to the brush recorder, which was maintained in the firing room to monitor the control and abort systems, tilt program, and premature cutoff. This information was provided to the RF abort panel operator so that RF abort capability would be monitored after liftoff. Shutdown of the engine in normal flight was accomplished by an integrator cutoff which differed from most other launch vehicles. An integrator clock panel was used in the GSE to check the integrator time. Engine combustion pressure switches were incorporated as a part of the automatic abort system to sense a loss of combustion pressure. Two methods were designed into the GSE to check the reliability and operation of the switches. First, a pressure simulator near the combustion chamber was used to check the pneumatic operation, and secondly, relays were utilized to check the circuit electrically.

A followup ground cable was added to insure that the ground potential of the vehicle remained the same as the ground potential of the GSE. During the initial investigation of the GSE, it was discovered that the Tempo relay timers being used were not reliable. These were replaced with Agastat timers. As a general rule, the masts and umbilical plugs of the launch vehicles were ejected pneumatically. In the case of this vehicle, the capsule umbilical plug was equipped with an electrical release backed up by a mechanical release. The electrical release caused some concern because of its failure to function properly during several preflight tests and on at least one occasion during a launch. However, since the mechanical release was proved to be reliable, no action was taken to correct the fault in the electrical release.

7.5.3 BLOCKHOUSE ELECTRICAL GROUND SUPPORT EQUIPMENT

7.5.3.1 General

The following specialized equipment, required for the launching of MERCURY-REDSTONE vehicles, was installed in the blockhouse on Vertical Launch Facility (VLF) 56.

7.5.3.2 Inverter Panel

The inverter panel, shown in Figure 7-12, was a standard inverter panel used for previous vehicles. It presented frequency deviations and voltage indications and contained controls for the ground and vehicle 115-volt, 400-cycle inverters.

7.5.3.3 Environmental Control Panel

The environmental control panel, shown in Figure 7-13, was used to control and monitor the launch vehicle instrument compartment cooling system. In addition, the instrument compartment could be pressurized by a manual control located on this panel.

7.5.3.4 Measuring Panel

The measuring panel, shown in Figure 7-13, provided control of all RF equipment on-board the vehicle which consisted of the telemeter, DOVAP, AZUSA, and television systems. An RF silence switch was installed in series with these controls to prevent the equipment from radiating during periods of RF silence.

In addition, the panel had a 5-volt measuring supply indicator with a switch to monitor either the ground or vehicle power supply, command receivers, control and function indicators, a control for arming the destruct package, miscellaneous switches to simulate DCR liftoff, thrust sensing line heater control, control voltage sensor abort blocking switch, and booster abort blocking switch. The thrust sensing line heater switch was a manual control used to turn the heaters on prior to power transfer. The block booster abort switches were used to prevent the capsule from receiving an abort signal from the booster during booster checkout.

7.5.3.5 Auxiliary Propulsion Panel

In addition to a test power switch, the auxiliary propulsion panel, shown in Figure 7-14, included the components test, instrument compartment pressure test, and the ac heater control. The test power switch provided power for the components test and

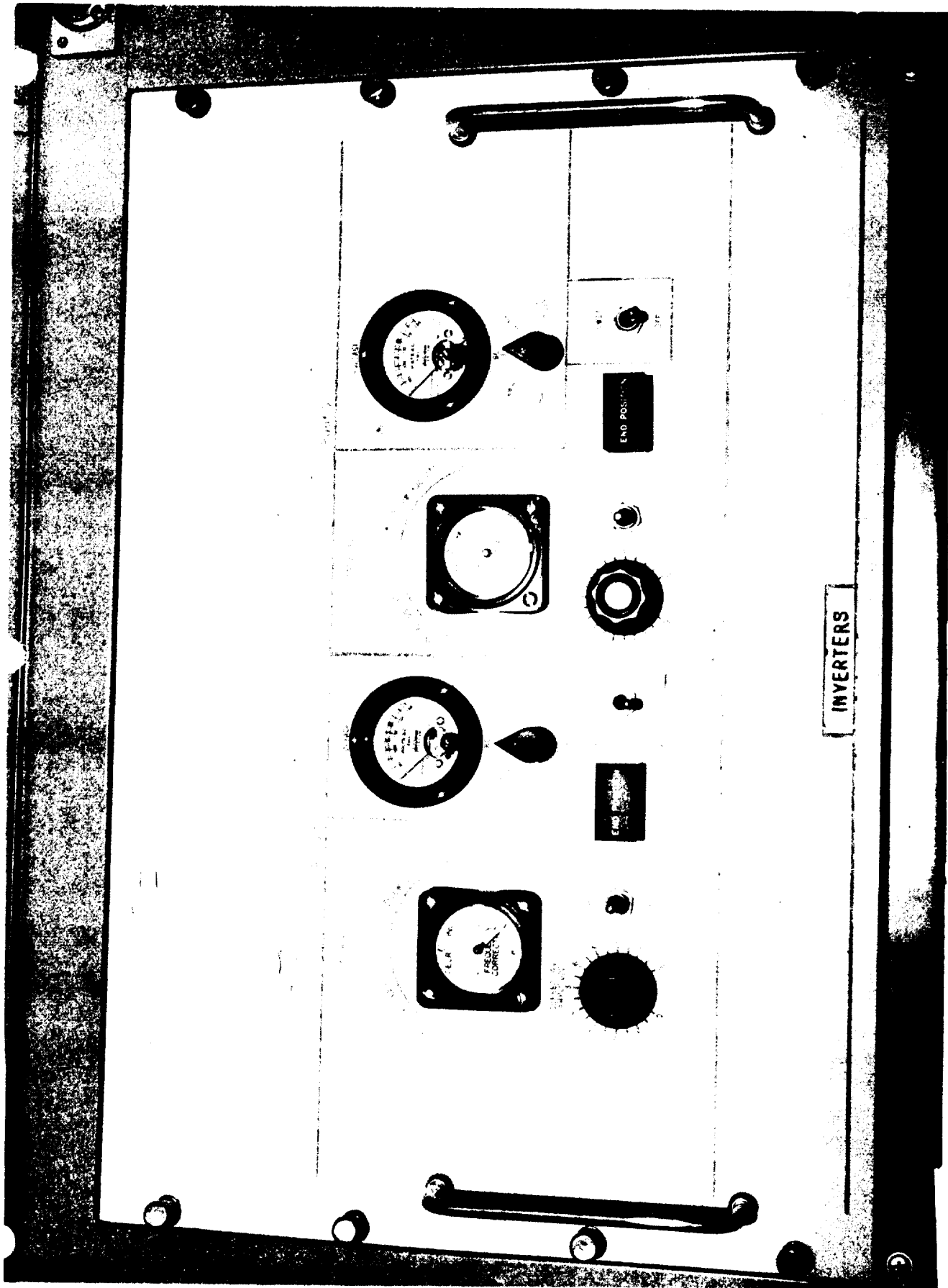

Figure 7-12. Inverter Panel, Blockhouse 56

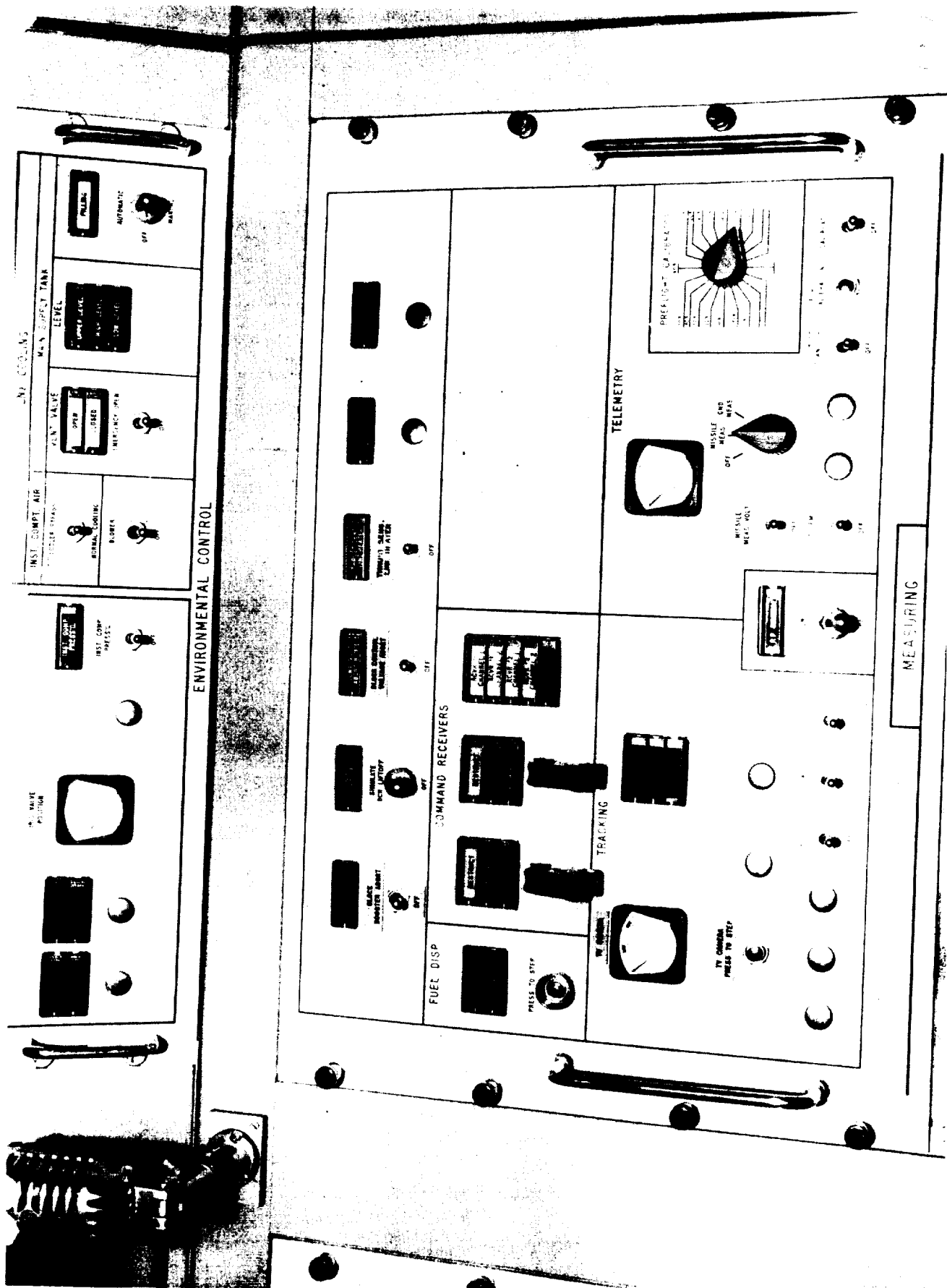

Figure 7-13. Environmental Control Panel and Measuring Panel, Blockhouse 56

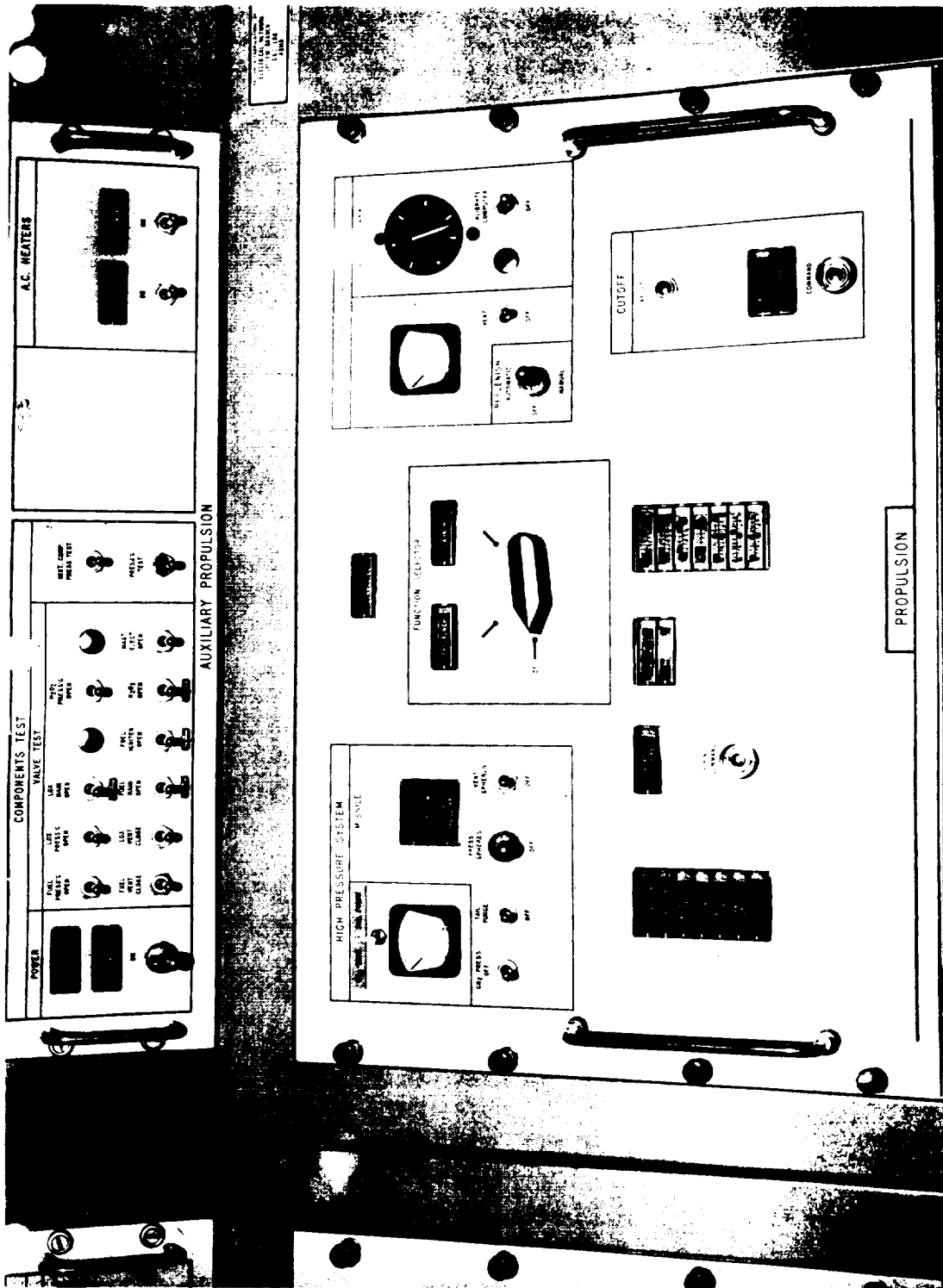

Figure 7-14. Propulsion and Auxiliary Propulsion Panels, Blockhouse 56

instrument compartment test portions of the panel. This switch was de-energized when the function selector switch was positioned in the launch position. The components test switches provided manual control for individually operating all the main valves in the propulsion system. The instrument compartment pressure test switch was provided to manually pressure test the compartment. The 115-volt, 60-cycle LOX valve and the hydrogen peroxide (H_2O_2) equipment heaters were also controlled from this panel.

7.5.3.6 Propulsion Panel

The propulsion panel, shown in Figure 7-14, was the standard model as used in previous REDSTONE missile launchings and contained a function selector switch, cutoff command and cutoff reset control, firing command button, high pressure system indications and controls, and the LOX replenish system indications and controls. In addition to the ready-to-fire and automatic sequence chains, the panel also presented the abort bus hot indication.

7.5.3.7 Over-all Test Panel

The over-all test panel, shown in Figure 7-15, was previously used as a portable console set up at the tail of the booster and removed after each test. For the MERCURY-REDSTONE Program, it was made a permanent item of GSE. The panel contained control switches for all the simulations of the vehicle during an over-all test, including: tank pressurization, boom drop, ignition, mainstage, liftoff, and combustion pressure switches 1 and 2.

7.5.3.8 Auxiliary Network Panel

The auxiliary network panel, shown in Figure 7-16, monitored and controlled specific MERCURY-REDSTONE functions. The panel contained the power transfer test switch and the emergency missile power-Off button. The sequence recorder control, cutoff indication light with a cutoff buzzer and arming switch, a voltmeter with a selector switch to monitor the abort batteries (when the abort battery switch was On), voltmeters to monitor the D104 and D105 ground busses, and indicator lights for signifying potential faults in the ground and vehicle inverters were also contained in this panel.

7.5.3.9 Generator Panel

The generator panel, shown in Figure 7-16, was the standard type used on all previous missiles. It provided a constant 28 volts for ground and vehicle power until the vehicle

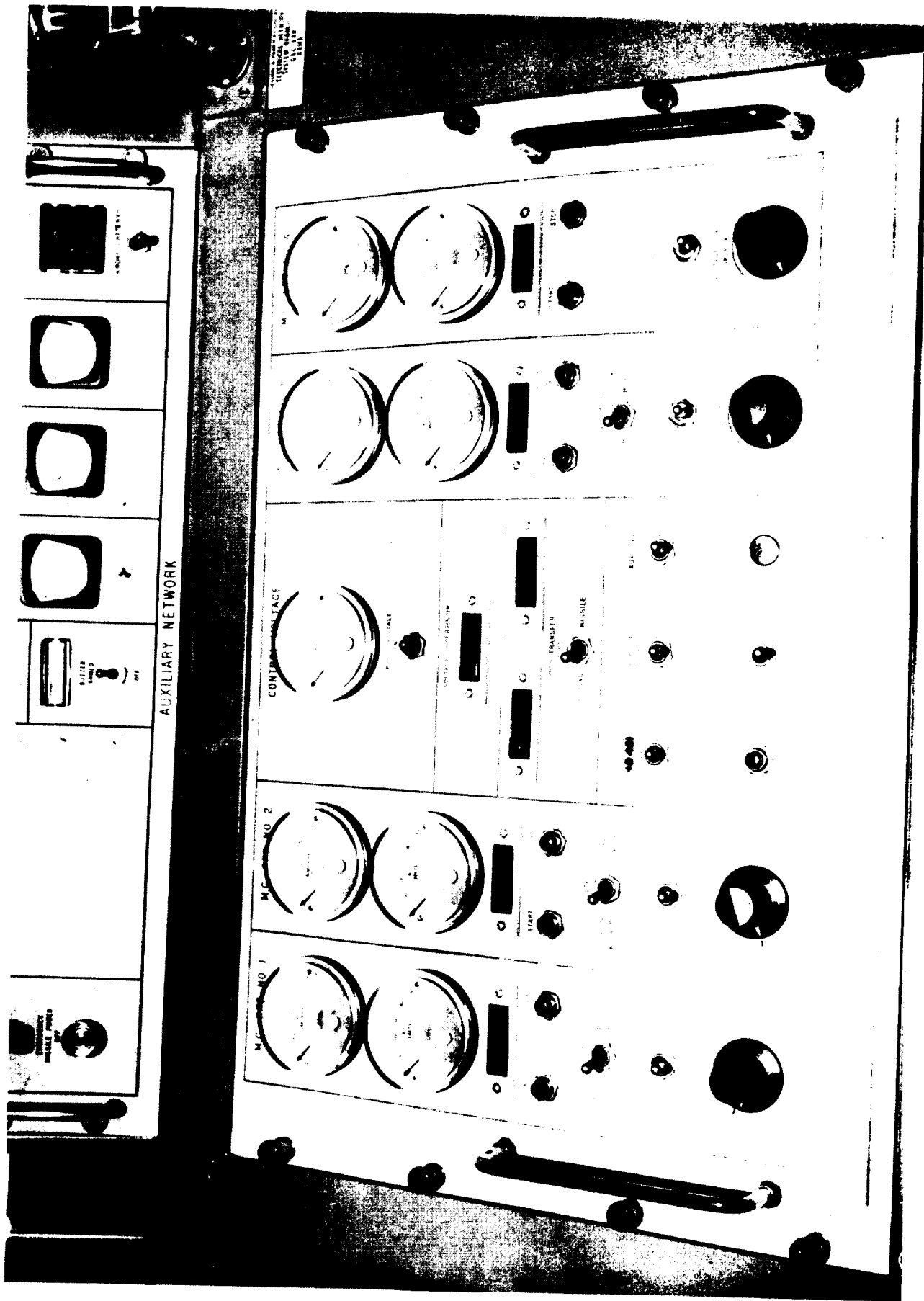

Figure 7-16. Generator and Auxiliary Network Panels, Blockhouse 56

was switched to internal power. Generators 1 and 2 provided voltages for the vehicle and associated ground equipment. Generator 3 provided 28 volts to the capsule monitor rack in the blockhouse and utility room. Generator 4 provided 28 volts for miscellaneous ground support not directly connected with the vehicle. The panel contained a voltage supervision indicator as well as ground and vehicle power indicators.

7.5.3.10 Autopilot Rack

The autopilot rack, shown in Figure 7-17, was composed of the control panel, autopilot (LEV-3) panel, and the integrator timer panel. In addition to monitoring the vane positions utilized for vehicle attitude control, the control panel provided the controls for the control computer, flight sequencer, and the program device, the LEV-3 control, and monitors for the gyro output.

Associated with the autopilot rack was a brush recorder that monitored the input of the control computer and the position of vanes II and IV. These signals were monitored only until liftoff.

7.5.3.11 Test Conductor's Console

The test conductor's console, shown in Figure 7-18, was made up of three panels consisting of the vehicle status and abort panel, countdown clock master control panel, and the communications panel. The master clock panel provided launch vehicle countdown and control by the launch test conductor. The communications panel gave the test conductor the ability to communicate with all blockhouse stations (except the black phone), the supervisor of range operations, and a range countdown speaker. The vehicle status panel at the left gives the status of critical functions determined essential for conduct of the countdown. Abort indications are given by lights and buzzer. Indications thus received are retained until positive action is taken.

7.5.4 COMMUNICATIONS

In addition to the usual communications used in all missile launches, the following special communications links peculiar to the MERCURY-REDSTONE manned flights, were utilized:

- Voice Communications with the Capsule
 - a. UHF radio link.
 - b. VHF radio link.
 - c. MOPIS (Missile Operational Interphone System) (prior to liftoff).

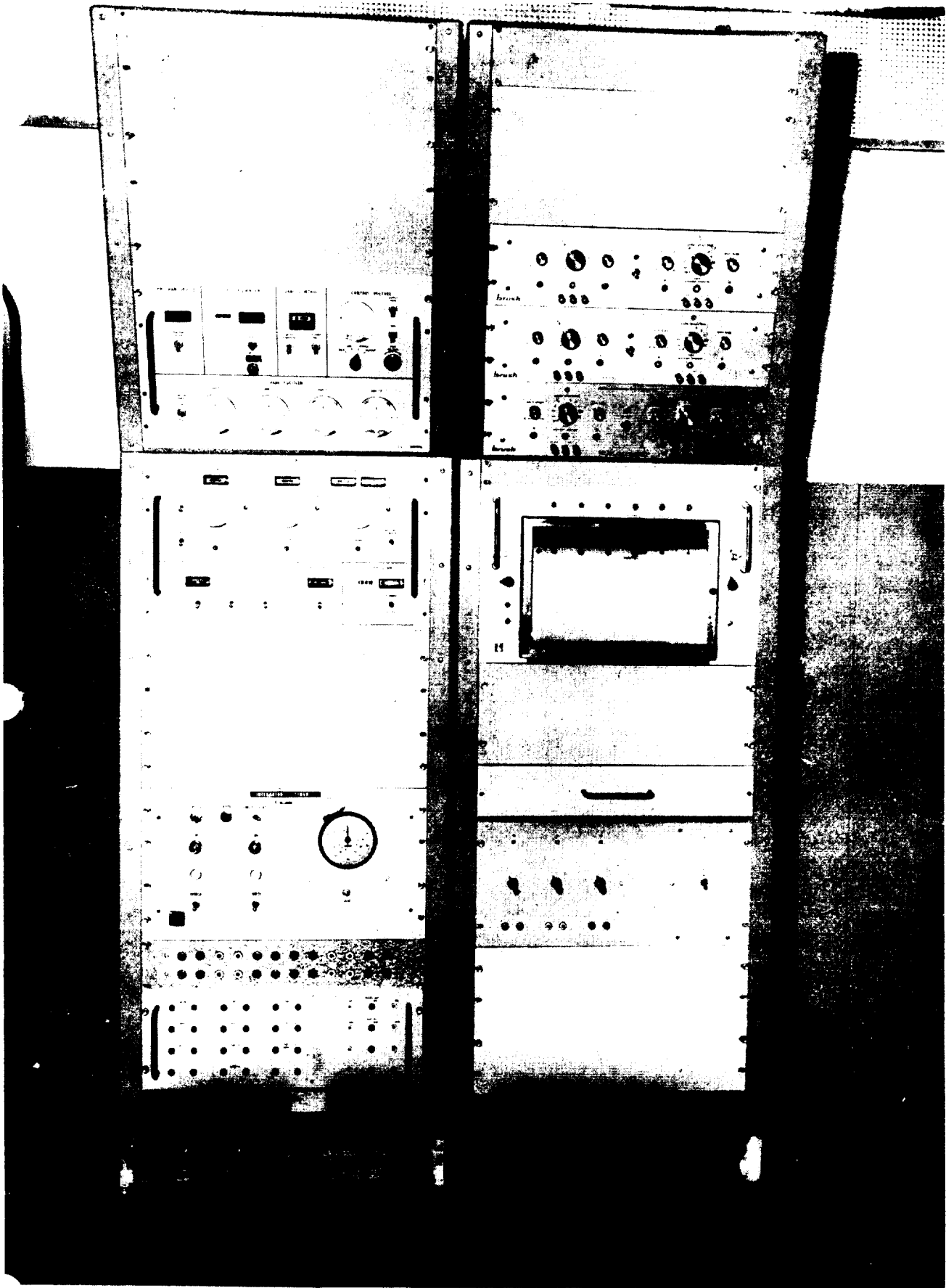

Figure 7-17. Autopilot Rack, Blockhouse 56

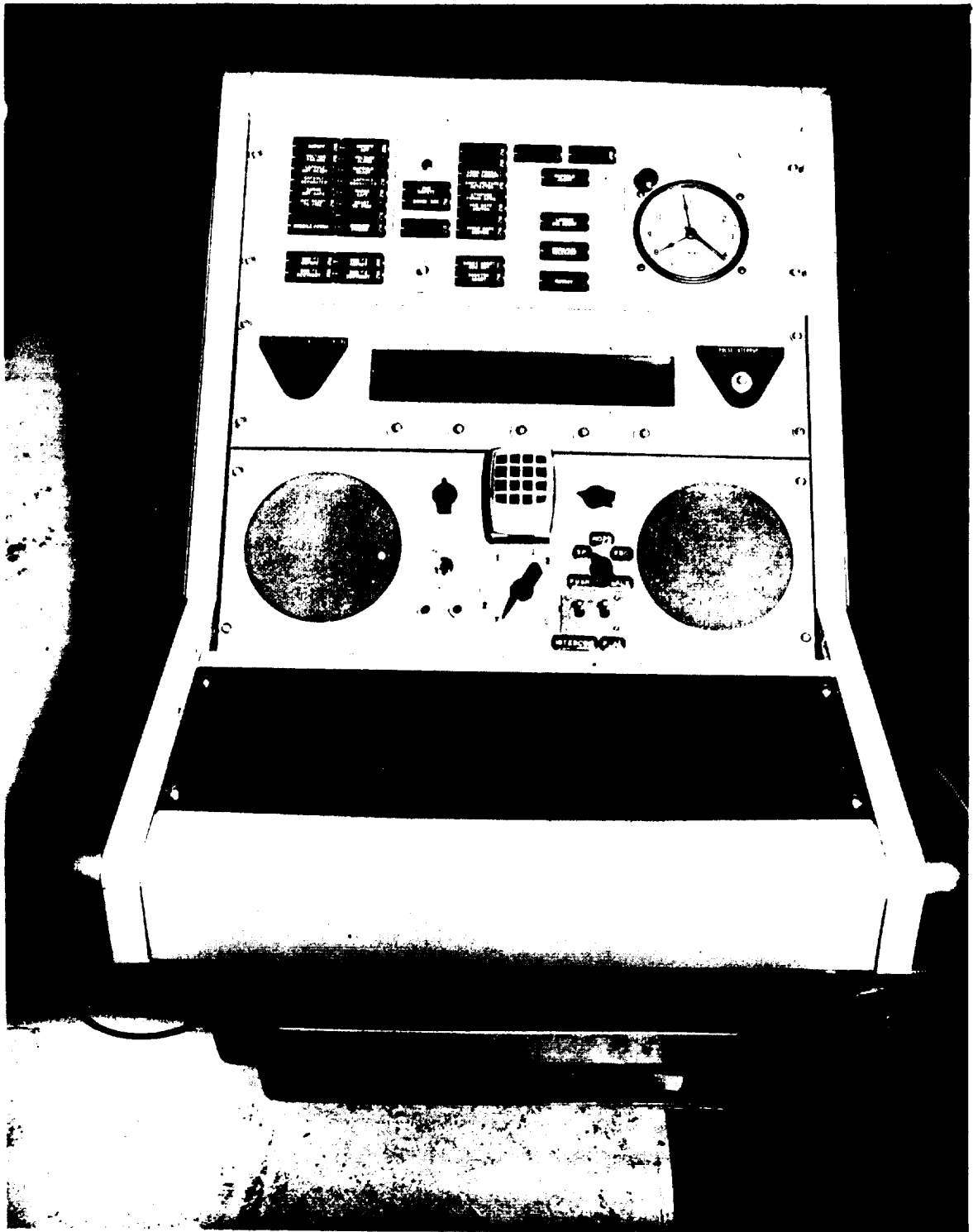

Figure 7-18. Test Conductor's Console, Blockhouse 56

- High frequency radio network for recovery and rescue operations operating on 30.3 mc.

Figures 7-19 and 7-20 show graphically the many participating individuals and agencies who had either a monitor or transmit-receive capability on one or more of these special communication links in support of launch operations.

A short time preceding the launch of MR-3, a NASA policy was established which permitted on-the-spot transmission of launch operations to the public. This required a crash program to provide this coverage and to organize operations so as not to interfere with the preflight procedures. To minimize interference with critical operations, it was decided to exclude live television from the blockhouse and MERCURY Control Center. In order to maintain security, the networks were required to provide one camera crew from a television pool, and a single mobile unit which was present until final service structure removal. One television camera was installed on level three and wired through Blockhouse 56 for use by the news media. Four television pictures were provided by the launch operations directorate from their closed-loop system used in support of operations. These five television channels were controlled by an LOD operator in Blockhouse 56. Television coverage thus provided was transmitted to Blockhouse 26 through cables provided by the news media. The command station at Blockhouse 26 was manned and monitored by commercial networks personnel. The mobile unit had the capability of direct broadcasting. A 208-volt power source was made available to the mobile unit from the Cape operational critical power. This mobile unit was located between Complexes 56 and 26 during the periods when access was permitted to the complex. This arrangement proved satisfactory and was repeated to a somewhat lesser degree during the launch of MR-4.

An informational telephone network was set up for each operation. A three-point operational telephone link was provided between the blockhouse, MSFC, and the Advisor to the Office of Launch Vehicle Programs at NASA Headquarters. An additional commentator link from the information center in Hangar R relayed information to Washington, MSFC, and local points, such as the press site. In addition, a commentator link was provided from the observation room of the MERCURY Control Center to the Office of Space Flight Programs at NASA Headquarters, Washington, D.C.

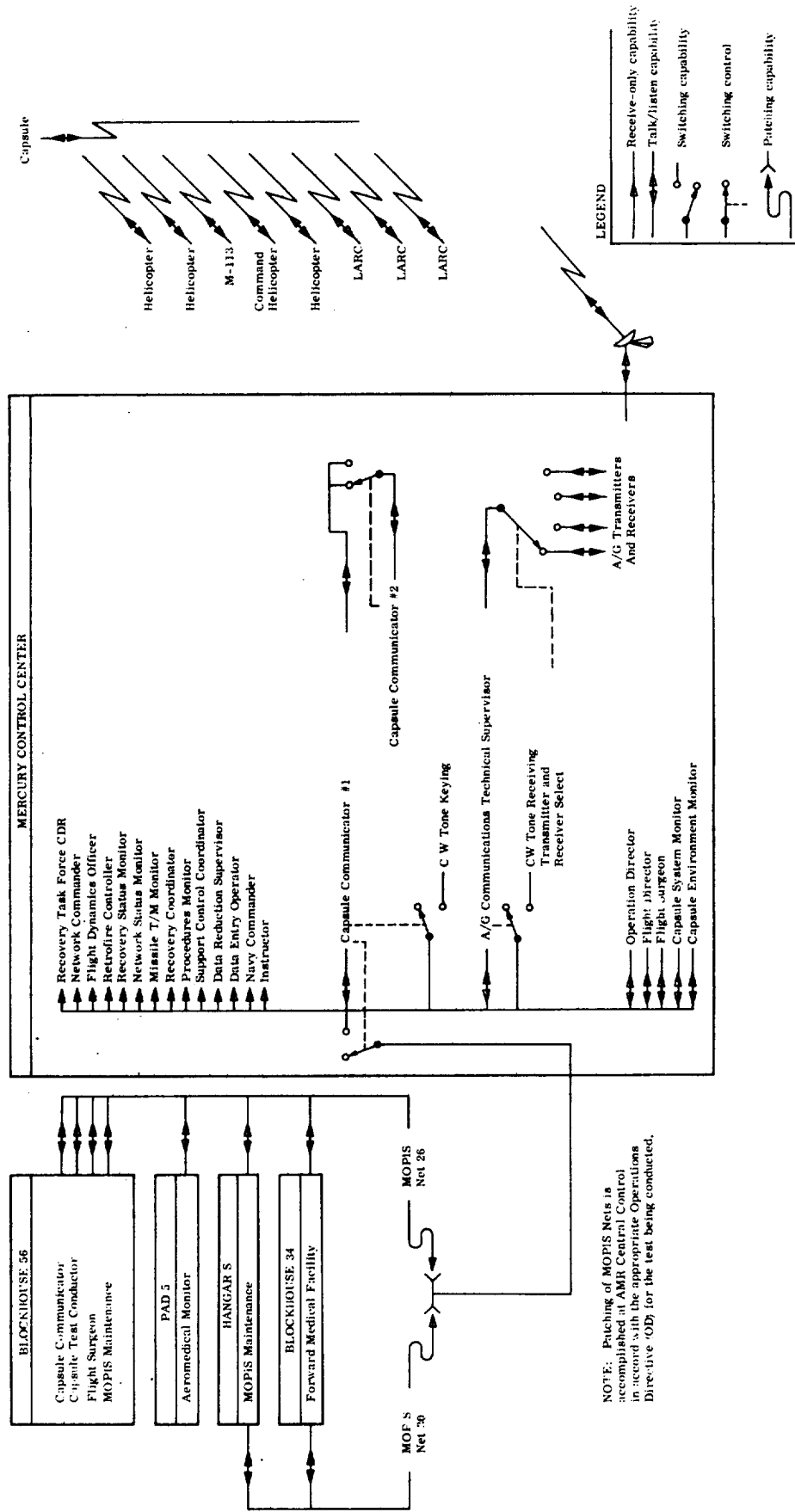

Figure 7-19. Capsule Radio Network - UHF

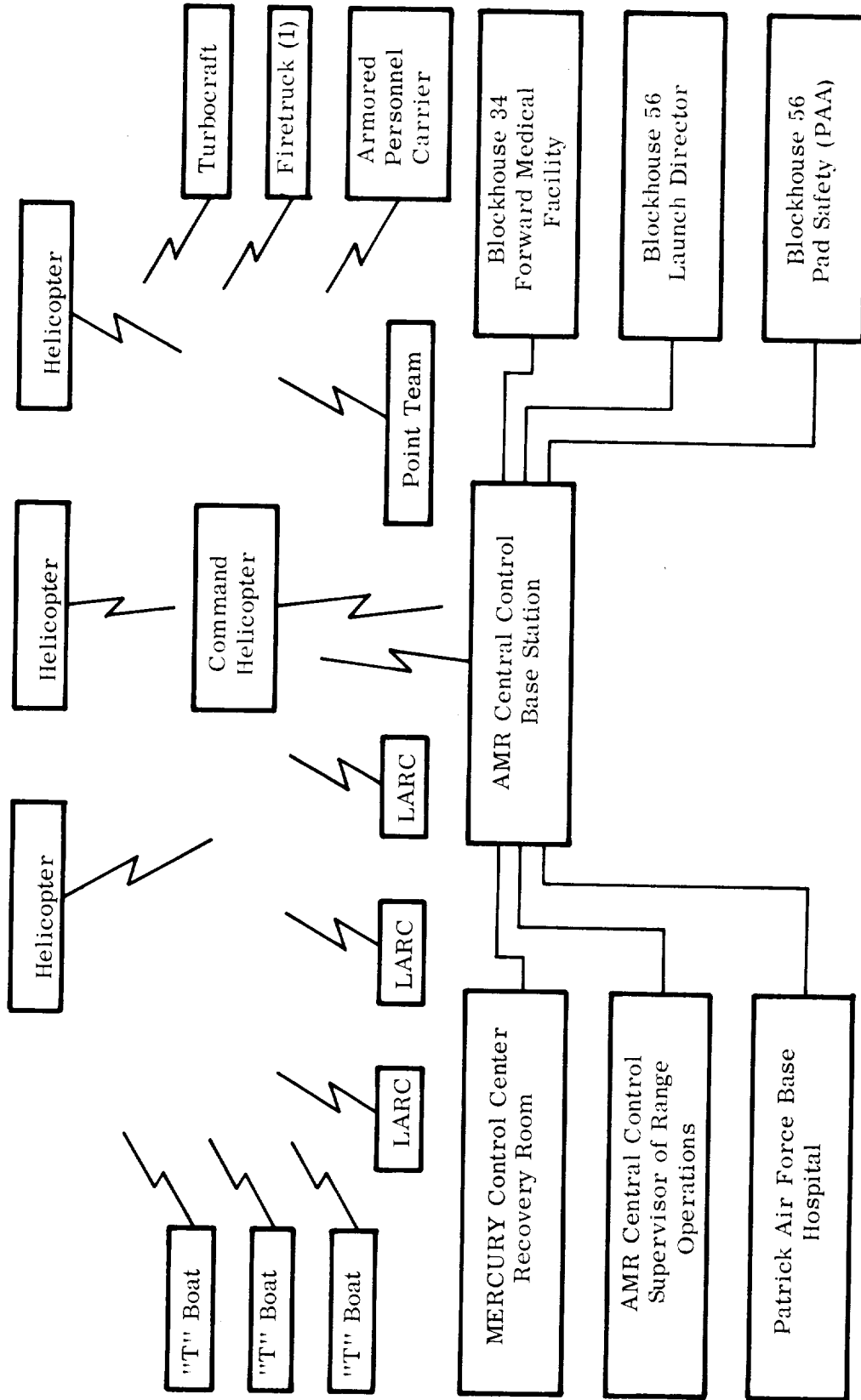

Figure 7-20. Recovery and Rescue Radio Network, High Frequency 30.3

7.5.5 INSTRUMENTATION

7.5.5.1 Monitoring Instrumentation

Instrumentation used at AMR for monitoring the launch of rockets was divided into four categories. These consisted of metric tracking instrumentation, engineering sequential and documentary photography, telemetry equipment, and flight safety equipment. For the MERCURY-REDSTONE flights another category was added which could be called "communications and recovery instrumentation." Much of this instrumentation fell into more than one category. Metric tracking data was required to evaluate the vehicle guidance and control performance, power plant performance, and aerodynamic effects. Photographic coverage was required to obtain a visual record of flight events. Telemetry was the primary means for obtaining data of onboard functions. Vibrations, strain measurements, guidance computer inputs and outputs, platform positions, gas turbine speed, combustion chamber pressure, and single events such as separations, retrorocket ignition, and parachute deployment, are samples of the type data obtained from telemetry. Flight safety instrumentation was used by RSO to monitor the vehicle during flight. Vehicle velocity, position, real-time impact point, and television monitors were displayed in central control for the RSO.

7.5.5.2 Metric Instrumentation

Metric instrumentation was broken down into two categories: electronic instrumentation and optical instrumentation.

- Metric electronic instrumentation consisted of the following:
 - a. C-band radars at Cape Canaveral, Patrick AFB, Grand Bahama Island (GBI), Carter Cay, and San Salvador tracked the C-band beacons in the MERCURY capsules. The ground stations, except Carter Cay, beacon tracked to loss of signal. Carter Cay tracked on passive beacon track and skin track. Uprange and GBI radars were available as tracking sources for the impact predictor. In addition to furnishing vehicle position and its derivatives, video cameras were operated on the phasing scopes to record the separation distance between the capsule and the booster. The C-band radar accuracies for MERCURY-REDSTONE varied from 0.6 to 91 meters from T+10 seconds to almost impact.
 - b. S-band Mod II radars located at Cape Canaveral, GBI, and San Salvador (AMR sites) and the S-band VERLORT (very long range

tracking) radar at Bermuda (NASA site) tracked the S-band beacons of the MERCURY capsules. The AMR S-band radars were operated as backup for the C-band radar, with the data to be reduced only if the C-band radar data were not sufficient. The quality of C-band data obtained in the MERCURY-REDSTONE program was such that S-band data reduction was not required.

- c. DOVAP (Doppler velocity and position) stations at Blockhouse 56, Hangar D, Lateral Site B, Program Site C, Merritt Island Airport, Titusville-Cocoa Airport, and Playalinda Beach, tracked the booster DOVAP transponders on a frequency of 73.738 mc. Transmitter site 1.3.4 on the Cape interrogated the beacon and provided a reference signal for the receiver stations. The accuracies of velocity and position data obtained, ranged from 0.1 meters per second to 1.7 meters per second and from 0.05 meter to 23 meters respectively, for powered flight. DOVAP was removed from the MR-1 and MR-1A flights, because the combined DOVAP transponder and a capsule telemetry transmitter blocked out the onboard command receiver. The telemetry frequency was changed on subsequent vehicles.
 - d. AZUSA Mark I and AZUSA Mark II were both utilized in the MERCURY-REDSTONE Program. Mark I was used for MR-1, MR-1A, and MR-2 flights, and Mark II was used for the MR-BD, MR-3, and MR-4 flights. The booster transponder was interrogated on 5000 mc and transmitted on 5060 ms. AZUSA data were used for the input to the impact predictor for flight safety presentation and also post flight metric data from approximately 20 seconds of flight through separation. Position accuracies varied from 0.03 to 5.8 meters for the same period.
- Metric optic instrumentation consisted of the following:
 - a. Fifteen fixed ribbon frame cameras, known as CZR's and RF-5's, were used as the primary metric data source from liftoff to 2000 feet. These cameras with 7- to 20-inch focal length lenses and variable frame format, operated with continuous running film using a synchronized system. The cameras were fixed in orientation, that is, they were not tracking cameras. The azimuth and elevation of the vehicle was determined by referencing the vehicle

- light source, paint pattern and/or the base of the flame to fixed reference targets in the field of view of each camera. Position errors varied from 0.04 to 0.1 meter for MERCURY-REDSTONE.
- b. Cine-theodolites with 24-inch focal length lenses and 35mm film size, tracked the vehicles from four sites on the Cape, Cocoa Beach, and Patrick AFB. The cine-theodolites photographed the vehicle, azimuth and elevation dials, timing pulses, and the frame count on each picture. This furnished backup data from liftoff to 2000 feet for the fixed ribbon frame cameras and primary data to approximately 150,000 feet altitude. Position accuracies varied from 1.2 to 2.9 meters.
 - c. Three attitude cameras, using 35mm film and lenses of 40-, 48-, and 60-inch focal length, tracked the vehicles to loss of view. Attitude data (pitch, yaw, and roll) were reduced from 0 to 2000 feet altitude. Yaw and pitch accuracies varied from 0.0 to 0.3 degrees.

7.5.5.3 Photographic Coverage

Photographic coverage was divided into engineering sequential and documentary camera coverage. Engineering-sequential cameras had range timing or a known frame rate, used to correlate visual observations to other data, while documentary cameras did not have range timing. The metric cameras naturally provide engineering sequential and documentary coverage, and engineering-sequential cameras also provided documentary coverage. Twenty fixed engineering-sequential cameras, running from 20 to 400 frames per second (fps), were operated in the vicinity of the launch pad. These cameras recorded specific details of the launch phase, varying from flame effects on the launcher to coverage of capsule umbilical plug ejection, and periscope retraction. Thirteen tracking engineering-sequential cameras were in operation on the Cape. Twelve 16mm cameras were running at 96 fps and one 35mm camera was running at 32 fps. These cameras provided general surveillance to loss of view from each camera. Long focal length cameras known as ROTI's (Recording Optical Tracking Instrument) and IGOR's (Intercept Ground Optical Recorder) were also used. ROTI's were operated at Melbourne Beach and Vero Beach using 20 fps and 30 fps, respectively and 500-inch focal length lenses. IGOR's were operated at False Cape (north of Cape Canaveral), Williams Point (north of Cocoa, Cocoa Beach, and Patrick AFB. Cocoa Beach and Patrick AFB operated at 30 fps with 360-inch focal length lenses, False Cape and Williams Point operated at 20 fps with 500-inch lenses.

7.5.5.4 Telemetry Links

Two telemetry links were carried on each MERCURY capsule with the same information transmitted on both links for redundancy. The REDSTONE boosters each had one link. These three links were recorded at Hangar D, Blockhouse 56, Cape TEL II, Cape TEL III, GBI, on one or two aircraft, and on one ORV (Ocean Range Vessel). Real-time displays of capsule data were made at MCC, using TEL III data, and a limited number were made at Blockhouse 56 and Hangar D.

7.5.5.5 System Displays

During original planning the STG requested that a booster performance and abort system display be provided in the MERCURY flight monitoring trailer. In the absence of firm information on the location and source of telemetry, and because of the limited space available in the flight monitoring trailer, this requirement was subsequently removed. In the interim, program slippage was such that the flight monitoring trailer was eliminated and the TEL III was used to monitor MERCURY-REDSTONE flights.

As a consequence, the STG re-established the request that this information be available within 5 or 10 seconds of demand to the Operation and Flight Director at the MCC to be monitored by a knowledgeable MSFC representative. As a result of this requirement, operating ground rules and measuring programs for the manned flights were established as explained in the following:

- The brush recorder displays utilized to monitor the abort system during the open-loop flights were expanded to monitor the manned flights. The abort switches under the left recorder were available to give a backup RF abort command after the first eight seconds by order from the MCC, and during the first eight seconds by request of the Launch Director as a backup to the abort switches. An additional special provision was included in this booster performance display that latched the abort bus signal in the On position in the event an abort signal was generated. Manual operation was required to either turn it off or verify. The input to the booster performance display was alternatively selected from two sources for complete coverage and reliability: (1) blockhouse telemetry receivers, and (2) the TEL II station telemetry receivers for the latter part of the flight. A direct telephone line was provided between the blockhouse booster performance display and the booster console at the MCC to assure immediate and positive exchange of information if an unexpected difficulty occurred during powered flight.

- The blockhouse booster performance display provided 12 channels of information on a brush recorder which was intended to reflect over-all booster performance, and not merely abort system functions. The following measurements were displayed:
 - a. Gyro pitch position minus program.
 - b. Gyro yaw position.
 - c. Gyro roll position.
 - d. Deflection jet vane No. 2.
 - e. Pressure combustion chamber.
 - f. Combustion pressure cutoff switch No. 1.
 - g. Abort bus signal.
 - h. Attitude error, abort.
 - i. Angular velocity, abort, pitch.
 - j. Angular velocity, abort, yaw.
 - k. Combustion pressure cutoff switch No. 2.
 - l. Control voltage abort.
 - m. Abort from capsule.
 - n. Capsule separation signal.
 - o. Emergency cutoff.
- An additional booster performance display was presented on an 8-channel recorder at the MCC for information purposes. The displayed information was transmitted by hardwire from the TEL II station receivers, discriminators, and decommutators to the MCC. There were no telemetry receivers available at the MCC for direct RF reception. Hardwire transmission over these lengthy cables was felt to contribute appreciably to noise and unreliability. The display of launch vehicle data to the MCC is listed as follows:
 - a. Abort bus signal.
 - b. Attitude error, abort.
 - c. Angular velocity, abort, pitch.
 - d. Control voltage abort.
 - e. Abort from capsule.
 - f. Angular velocity, abort, yaw.
 - g. Combustion pressure cutoff switch No. 2.
 - h. Combustion pressure cutoff switch No. 1.
 - i. Tilting program, LEV-3.
 - j. Input to flight sequence.

- k. Gyro pitch position, minus program.
- l. Acceleration of missile, longitudinal.
- m. Acceleration of missile, fine, longitudinal.
- To assure that the best information from qualified sources was available within the shortest possible time, the following ground rules were established:
 - a. The MCC console was monitored by the MSFC Project Director and an LOD measuring engineer.
 - b. The measuring engineer forwarded booster information to the Flight Director after verification with the blockhouse on any of his observations within 15 seconds, depending upon circumstances.
 - c. The blockhouse booster performance display was monitored by the Deputy Director and Deputy Chief, Measuring and Tracking Office.
 - d. The blockhouse had the capability of selecting telemetry receiving stations to assure the best available data.
 - e. The MCC did not take command action solely on the basis of MCC booster performance data.

7.5.5.6 Communications for Recovery

The communications transceivers aboard the capsules could have been used as a backup homing signal for the ships, helicopters, and aircraft of the recovery force. A UHF SARAH (search and rescue and homing) beacon and an HF SEASAVE beacon were carried on the capsules for homing purposes after re-entry; two UHF and two HF voice transceivers were also carried. On the unmanned flights, recorded messages were transmitted from the capsule. Communications were maintained between capsule, Cape MERCURY Control Center, GBI, and the recovery force.

7.5.5.7 Abort Landing Predictor

One support system of interest was the Abort Landing Predictor. Because of the slow rate of descent and the resulting high wind drift of a MERCURY capsule, the usual impact prediction method was not considered adequate. Using winds aloft data, available at T-5, 4, and 2 hours, the LOD Burroughs 204 computer was programmed to calculate the capsule landing points, assuming an abort occurred at intervals of four to eight seconds during a normal booster flight. A trace of the abort landing points, with corresponding times, was given to the MERCURY Control Center. Had there been an abort, personnel could have obtained an approximate landing point by observing

the recorded abort time and the plotted landing point. Information thus provided, permitted the MERCURY Control Center to determine whether a Cape abort would result in an unsafe area, and hold the count pending more favorable wind conditions, if necessary.

7.6 METEOROLOGICAL ASPECTS

7.6.1 GENERAL

Weather input to the MERCURY-REDSTONE Program was a divided responsibility. The Atlantic Missile Range, the MERCURY network, and the MERCURY recovery forces, all supplied observational data. Forecasts were supplied by the Project MERCURY Weather Support Group of the United States Weather Bureau. While a small duplication of capability existed in this arrangement, there is no question of the need for the additional worldwide meteorological support that Project MERCURY Weather Support Group provided, especially weather information about recovery areas, and extended-range forecasts.

7.6.2 WEATHER RESTRICTIONS

7.6.2.1 General

Weather restrictions that affected the MERCURY-REDSTONE Program may logically be grouped into two categories as follows:

- Nominal mission restrictions.
- Aborted mission restrictions.

7.6.2.2 Performance Restrictions

Performance restrictions are those which might affect the performance of the spacecraft and booster combination in a normal mission. This group may be subdivided into three categories: (1) the booster-capsule combination during launch phase, (2) the capsule's capability of surviving a landing, and (3) the capability of successfully recovering the capsule.

7.6.2.3 Arbitrary Restrictions

The restrictions of this category were those which have no specific effect upon the successful completion of an operation, but became of utmost importance if a failure occurred during the boost phase. Optimum optical observation of the booster-capsule

combination through the zones of maximum dynamic pressure and through the separation of the escape systems was mandatory for a manned flight.

7.6.3 WEATHER MINIMUMS

The MERCURY-REDSTONE booster itself was subject to easily satisfied weather minimums in the Cape Canaveral launch area. Required weather minimums are as follows:

- Precipitation occurring during the launch countdown phase could hamper certain launch preparations such as liquid oxygen tanking.
- Lightning storms present a hazard to missile preparation, particularly relating to ordnance devices.
- Ground winds, especially gusts, are a limiting factor after removal of the service structure. An 18-knot (sustained) or 25-knot (gust) wind limitation was the standard used for all MERCURY-REDSTONE operations. Winds of higher velocity than this were experienced only about 10 percent of the time.
- Winds aloft, at the prevailing level of the jet stream placed the most severe limitations upon the MERCURY-REDSTONE. The critical speed is a function of both direction and speed, as well as vertical shear. During the cooler months, winds aloft are sufficiently strong on about 30 percent of the time to require flight simulation before conducting launch operations, but only about 10 to 15 percent of the time are winds sufficiently strong to prevent launching. During the warm months upper winds are not a factor. Once a strong jetstream maximum becomes established over the Cape Canaveral area, it is characteristic that it persists for several successive days. Critical periods arising out of strong winds aloft, alternating with periods of no upper wind problem, last up to a week or more. Such conditions lend themselves to reasonably reliable prediction.

7.6.4 SURFACE WINDS

The MERCURY capsule was subject to a variety of weather restrictions, most important of which is the surface wind and its attendant state of the sea. Structural limitations and the capsule's relatively small size limit its capability of surviving a landing in rough seas. Since an abort off the pad, or during the boost phase, might result in a landing at any point along the planned trajectory or in the immediate vicinity of the launch pad, wind and sea state minimums must be satisfied all along the range. The

frequency of limiting winds and seas in the Cape Canaveral area or along the trajectory is not high, but may occur in connection with a great variety of synoptic weather patterns, at any time during the year (most frequently during the cool months).

7.6.5 CEILING AND VISIBILITY

Successful recovery leads to even more weather limitations. The limit of wind and sea state applicable to a safe landing is critical for safe recovery. Since recovery may involve an aircraft search phase, the elements of ceiling and visibility in the recovery area are also critical. The frequency of unfavorable ceiling and visibility that would hamper search operations are relatively low.

7.6.6 OPTICAL COVERAGE (CLOUDS)

The total amount of sky coverage of the Cape Canaveral area exceeds 40 percent more than half the time, with no great variability in the mean throughout the year. Cloudiness in excess of 30 percent was selected as the limiting factor, but only as a starting point. Capability of the cameras to track a rising missile is virtually unpredictable. This capability is dependent upon many factors other than the amount of cloudiness present at a given time. It has been known to range from less than 20 percent capability under sky coverage of less than 1/10 all the way to 80 percent capability under 7/10 opaque sky. Only under conditions of clear sky, or 10/10 opaque cloud coverage, could camera capability be predicted accurately.

The MERCURY-REDSTONE Program enjoyed more than a fair share of good weather conditions. Of nine scheduled launches that proceeded to within one hour of planned launch time, weather conditions were a factor in four launches, two of which were scrubbed because of weather. In every case of weather limitation, optimum optical coverage was the problem. It is noteworthy that the four cases, in which weather necessitated cancellation or delay, occurred during the warm season; whereas, those unaffected by weather occurred during the colder months. Weather during the cooler seasons tends to run in cycles of excessive cloudiness alternating with clear skies within periods of several days, consistent with the movement of major fronts across North America. There is no such consistent relationship during the warmer months; thus, the winter-time phenomena lend themselves to a much more reliable prediction. While weather delays were not necessary during the launches scheduled for the cooler months, strong jet stream level winds were a definite threat on two occasions, and surface wind conditions in recovery areas barely subsided to acceptable limits on another occasion.

7.6.7 METEOROLOGICAL SUPPORT

Within the limits of forecasting capability, meteorological support to the MERCURY-REDSTONE Program left little to be desired. Prediction of moment-to-moment variability in sky condition, such as occurred at the launch site during the last few hours of the countdown of both MR-3 and MR-4, is not feasible. Aircraft reconnaissance of the near vicinity is of inestimable value in the case of middle or high cloudiness, but serves little purpose for low clouds, which have a tendency to form over the Cape area rather than being carried over by the prevailing winds. Clouds of the latter variety present no real obstacle to system performance but are most restrictive to optical tracking. Project MERCURY Weather Support Group's radar compositing technique, involving WSR-57 equipment at Miami, Tampa, and Daytona Beach, proved to be a very useful means of keeping under surveillance large-scale convective disturbances beyond the range of a single radar at Cape Canaveral.

*

SECTION 8

FLIGHT TEST PROGRAM

8.1 INTRODUCTION

The flight test program consisted of six flights in three phases. The first three flights provided checkout and data for both capsule and launch vehicle designers. The fourth flight was a final booster development test prior to the manned shots. The last two flights were the manned operational flights providing the suborbital testing of the MERCURY capsule. Table 8-1 is a summary of the flights.

Table 8-1
Summary of the MERCURY-REDSTONE Flight Test Program

Flight Number	Launch Date	Booster Number	Capsule Number	Payload				
MR-1	21 Nov 1960	MR-1	S/C - 2	Simulated man				
MR-1A	19 Dec 1960	MR-3	S/C - 2	Simulated man				
MR-2	31 Jan 1961	MR-2	S/C - 5	Chimpanzee- "Ham"				
MR-BD	24 March 1961	MR-5	Boilerplate					
MR-3	5 May 1961	MR-7	S/C - 7	Astronaut Alan Shepard				
MR-4	21 July 1961	MR-8	S/C - 11	Astronaut Virgil Grissom				
Parameters			MR-1A	MR-2	MR-BD	MR-3	MR-4	
Flt path \angle at cutoff (deg fr local vert)			41	40.4	41	41	41	
Velocity at cutoff, space fixed (ft/sec)			7200	8590	7514	7388	7580	
Maximum altitude (nautical miles)			113.56	136.43	98.63	101.24	102.76	
Range (nautical miles)			204.0	363.0	276.1	263.1	262.5	
Maximum Dynamic Pressure (lb/ft ²)				576	556	586	605	
Thrust, Sea level (lbs)				82,680	78,780	78,860	79,220	
Engine Specific Impulse, Sea level (sec)				217.2	216.3	214.8	217.4	
Weight, liftoff (lbs)					66,116	66,098	65,976	
Launch Time (EST)			1115	1154	1230	0934	0720	
Launch time delay, veh caused, (min)			0	74	0	53	0	

Table 8-1

Summary of the MERCURY-REDSTONE Flight Test Program (Cont'd)

Parameter	MR-BD	MR-3	MR-4
Pitch (% abort limit)	16	17	20
Roll "	34	12	12
Yaw "	29	13	24
Pitch rate "	35	22	50
Yaw rate "	14	14	14

The flight program described in this section pertains only to that of the MERCURY-REDSTONE booster. There were two other MERCURY flight test programs being conducted during this same period. One of these was a capsule separation and abort checkout program using LITTLE JOE booster. A total of seven flights and one beach abort test were made. In addition, a MERCURY-ATLAS development program was being conducted simultaneously with one BIG JOE and three MERCURY-ATLAS flight attempts occurring before the final MR-4 flight.

8.2 DEVELOPMENT FLIGHTS

8.2.1 GENERAL

The first three MERCURY-REDSTONE flights, MR-1, -1A, and -2, were development flights to prove the adaption of the REDSTONE to the MERCURY suborbital mission and the interfaces with the MERCURY capsule. All flights were made from Launch Complex 56 at Cape Canaveral, Florida. In addition to testing the booster and capsule, these flights prepared the launch personnel for the manned flights to follow. A discussion of the launch operations will be found in Section 7 of this report. As noted, for half of the flights (MR-1, -1A, and -BD), the abort sensing system was flown open loop, that is, no abort would occur even if conditions required an abort. This was done to preclude a mission failure due to a malfunction of the abort system.

MERCURY-REDSTONE Flight MR-1 was launched on 21 November 1960 from Pad 5 of Launch Complex 56. The primary mission was to obtain an open loop evaluation of the automatic inflight abort sensing system and to qualify the spacecraft/launch vehicle combination for the MERCURY ballistic mission, which included obtaining Mach 6.0 during the powered portion of the flight and successful spacecraft separation.

Prior to the launch on 21 November, a launch attempt was made on 7 November 1960. This attempt was scrubbed at T-22 minutes when a low hydrogen peroxide pressure indication in the capsule was discovered. Previously, a 60-minute hold at T-120 minutes was made to correct difficulties with the spacecraft's hydrogen peroxide system.

MR-1 was the combination of Booster MR-1 and Spacecraft 2. The firing command was given from the blockhouse at 0859 EST and normal ignition occurred. At first motion of the vehicle an engine shutdown signal was given. Prior to complete shutdown the thrust was sufficient for MR-1 to rise 3.8 inches, then settle back on the pedestal. The engine shutdown signal also caused the capsule escape tower to be jettisoned. Still surrounded by the smoke created by the jettison rockets the vehicle tilted slightly on its pedestal, but remained erect. The capsule's drogue chute deployed, then its main parachute, and finally the auxiliary chute. Still attached to the capsule, which had remained on the booster, the chutes fell to the pad. (Figure 8-1.)

After the first three seconds, the vehicle rested on the launch pedestal, fully fueled and armed. Liquid oxygen was venting and the fin frames were deformed due to the force of impact. No power or command connections with ground support equipment remained after liftoff; therefore, no control could be exercised over the booster or the capsule. To prevent further damage, especially the possibility of accidental signaling of the destruct system, range safety left the command carrier on throughout that day and the following night to insure saturation of the receivers thereby blocking them from detecting any spurious signals.

The vehicle was allowed to remain on the pad to evaporate the liquid oxygen. The following morning the LOX tank was vented, as were the high-pressure nitrogen spheres in the engine pneumatic system. The fuel and the hydrogen peroxide tanks were then emptied. All circuits were deactivated, the service structure was moved into place, and lastly the destruct system arming device and primacord were removed.

The investigation which followed found the cause of the engine shutdown to be due to a "sneak" circuit created when the two electrical connectors in Fin II disconnected in the reverse order. Normally the 60-pin control connector separates before the 4-pin power connector. However, during vehicle erection and alignment on the launch pedestal, a tactical REDSTONE control cable was substituted for the specially

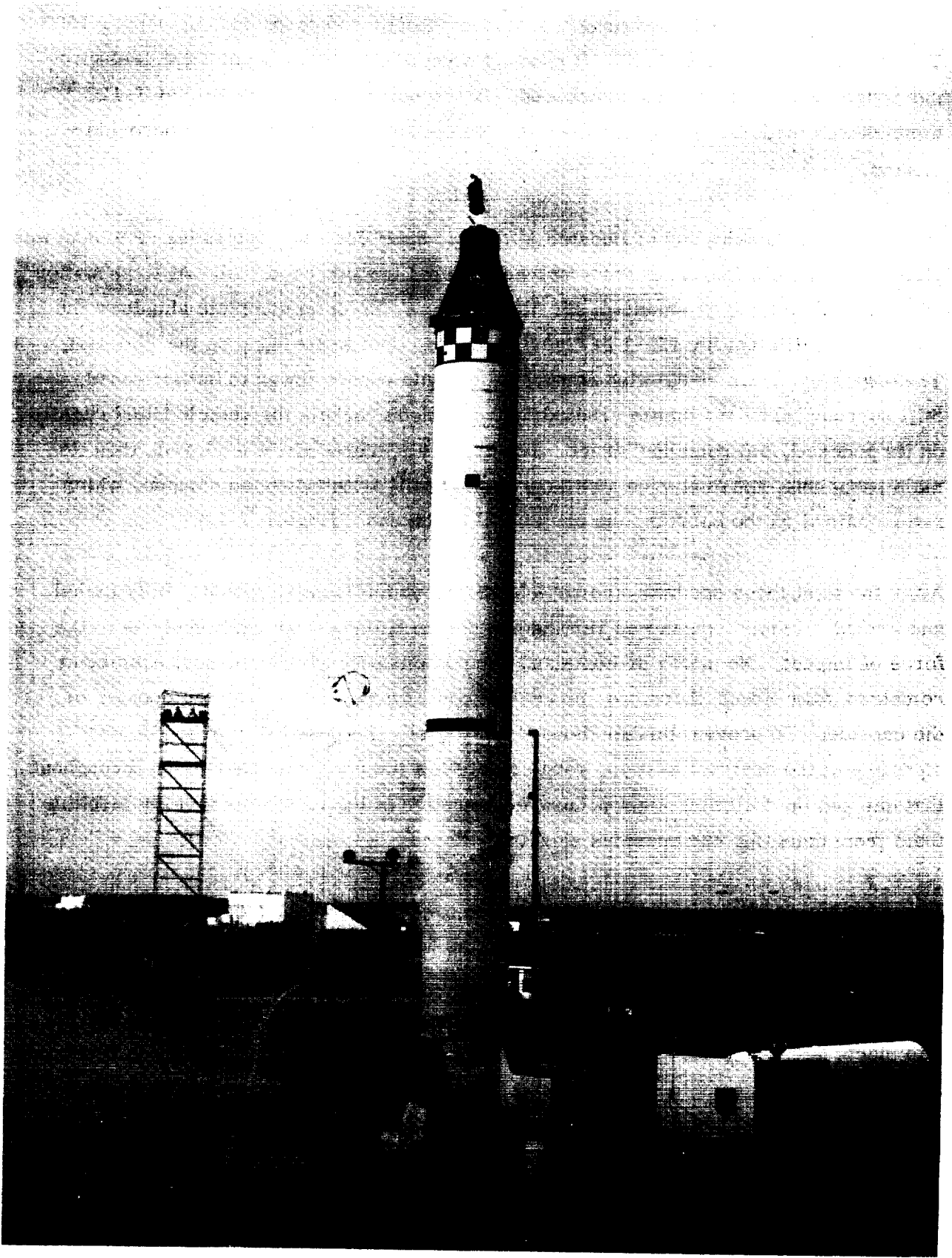

Figure 8-1. MERCURY-REDSTONE MR-1 During Parachute Deployment

shortened MERCURY cable. The cable clamping block was then adjusted, but apparently not enough to fully compensate for the longer REDSTONE cable.

Because of the improper mechanical adjustments, the power plug disconnected 29 milliseconds prior to the control plug. This permitted part of a three-amp current, which would have normally returned to ground through the power plug, to pass through the "normal cutoff" relay and its ground diode. The cutoff terminated thrust and jettisoned the escape tower.

The spacecraft did not separate from the launch vehicle because the g-load sensing requirements in the spacecraft were not met. "Normal cutoff" started a 10-second timer which, upon its expiration, was supposed to signal separation if the spacecraft acceleration was less than 0.25g. (This sequencing was designed to minimize the occurrence of a spacecraft launch-vehicle recontact.) However, MR-1 had settled on the pad before the timer expired and the g-switch, sensing 1g, blocked the separation signal.

The barostats properly sensed that the altitude was less than 10,000 feet and therefore actuated the drogue, main, and reserve parachutes in the proper sequence. The reserve parachute was released because no load was sensed on the main parachute load sensors.

To prevent a second occurrence of this problem a "ground strap" approximately 12 inches long was added to maintain vehicle grounding throughout all liftoff disconnections. Changes were also made in the electrical network distributor to prevent a cutoff signal from jettisoning the escape rocket and tower prior to 129.5 seconds after liftoff; for by jettisoning the tower on the pad, the abort mode of escape was lost and a potentially hazardous condition would have existed if the flight had been manned. This safety measure was accomplished by modifying the flight sequencer to generate an arm cutoff to capsule signal. If the pressure in the combustion chamber was normal at 129.5 seconds and the capsule cutoff circuit was armed, a normal booster cutoff signal could then be received by the capsule to start the tower jettison sequence. An arm cutoff to capsule signal switch was also added to the blockhouse propulsion panel.

Examination of the booster and capsule indicated both could be reused after refurbishment. Since the capsule was not damaged it was subsequently used on MR-1A.

However, MR-1's tail assembly sustained minor damage so it was decided to use booster MR-3 for the next flight. MR-1 was then returned to MSFC where it was held in reserve. At the conclusion of the program, MR-1 remained at MSFC and is now on display at the Space Orientation Center. Table 8-2 lists the sequence of events for the MR-1 flight.

Table 8-2
MR-1 Sequence of Events

Event	Range Time (+0.001 sec)	Comment
First Motion	0.600 ± 0.025	Cutoff condition generated
Power plug disconnect	0.609	
Cutoff (system signal)	0.617	
Cutoff (measuring signal)	0.635	
Control plug disconnect	0.639	
Liftoff (measuring signal)	0.648	
Abort bus energized	0.752	
Escape tower jettison	0.775 ± 0.010	
Telemetry interference due to jettison rocket exhaust	0.775 - 1.1	
Chamber pressure decays to 0	1.3 - 1.4	
Recovery system armed, and drogue chute deployed	3.775	

8.2.2 FLIGHT MR-1A

Flight MR-1A was composed of the MR-3 launch vehicle and the No. 2 spacecraft. The flight achieved the mission objectives set for MR-1. The capsule was the same one used on flight MR-1 except for replaced parts and minor modifications, such as, a tri-nozzle on the tower jettison rocket and the resetting of the parachute deployment backup barostats at 21,000 feet. The capsule was mated with the launch vehicle on 8 December 1960, and the simulated flight test was successfully run on 17 December 1960. Launch procedures were arranged in a split countdown of 250 minutes on 18 December and 360 minutes on the following day. The second part was started at 0222 EST but a leakage in the capsule's high pressure nitrogen line and a faulty solenoid valve in the peroxide system of the capsule required correction causing a launch delay of three hours and 15 minutes.

At 1115 EST on 19 December 1960, the space vehicle was launched from Launch Complex 56 and successfully met its objectives (Figure 8-2). During the flight all abort measurements remained between the limits and the abort system functioned as expected. Malfunction of the velocity integrator, however, caused the vehicle velocity cutoff to be 260 fps higher than normal, thus boosting the capsule 6 miles higher than the predicted 128 miles and resulted in a capsule re-entry deceleration approximately 0.4 to 1.0 g above the predicted 11.0 g maximum. The capsule also traveled 20 miles further downrange than predicted. High tail winds (up to 203 feet per second) and the "popgun effect" at separation were also contributing factors to the increased range and deceleration.

A thorough laboratory check of the integrator was made and the source of the malfunction identified as excessive torque against the pivot of the accelerometer caused by eight electrical wires. Relocation of five of the wires and use of a softer wire material (85 percent silver, 15 percent copper) on the remaining three wires solved the problem as demonstrated by the MR-2 and MR-BD flights. A backup cutoff timer was also used during these flights, but it was removed for MR-3 and MR-4 because the modified velocity integrator operated properly.

The abort system was also flown open loop on MR-1A. All sensors showed levels well below the abort limits, and the system was de-energized at engine cutoff, as designed. The pitch abort sensor indicated an abort condition of 5.4 degrees some 7.6 seconds after engine shutdown. The condition was attributed to nose-up thrust from the LOX vent.

High LOX flow coupled with low fuel flow gave an oxidizer to fuel mixture ratio 3.6 percent higher than predicted; however, the residual propellants were sufficient to insure full duration of engine operation.

Vehicle control was proper throughout powered flight, but small amplitude vibrations were measured. The first mode frequencies of 3.5 cps appeared during the first 10 seconds of flight. The second mode frequencies occurred randomly and varied from about 6.5 cps near liftoff to about 9 cps at cutoff. The angle of attack reached a maximum of 6.0 degrees.

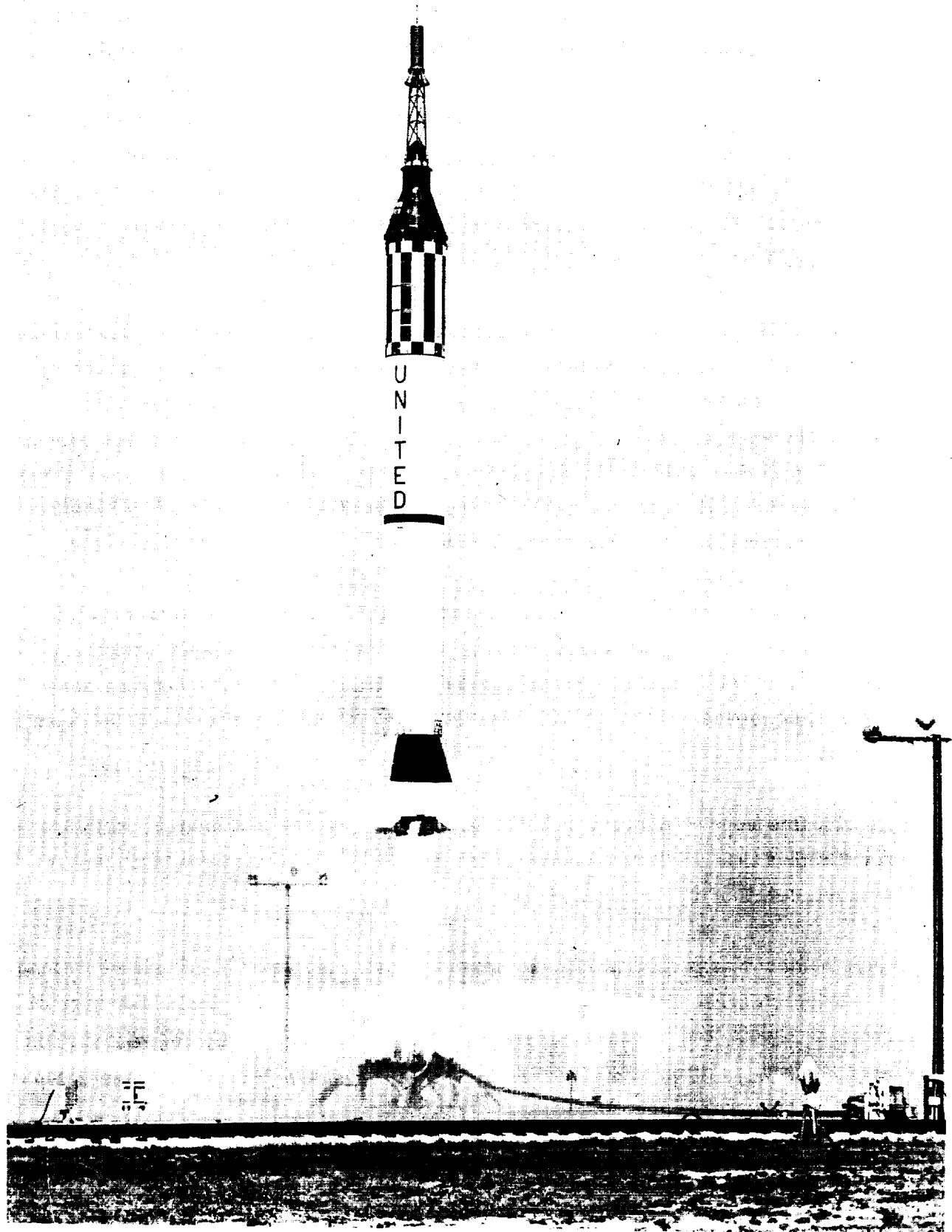

Figure 8-2. Liftoff of MERCURY-REDSTONE MR-1A

A vibration transducer was located on the abort rate switch mounting bracket in a longitudinal direction and another was mounted in a lateral direction on the capsule adapter mounting ring. The vibrations indicated by both transducers were approximately the same throughout powered flight; i. e., ignition was reflected by a sharp increase in acceleration levels as was the liftoff phase. The vibrations attained a maximum of 4.5 g's during liftoff (over-all) then decreased to a negligible magnitude at 10 seconds. At 30 seconds, the vibrations gradually increased to another maximum at 70 to 80 seconds. This latter maximum exceeded the range of the sensors but showed predominant frequencies in the 500 to 1200 cps area. The vibratory acceleration level then decreased gradually and by 130 seconds was again negligible. Cutoff and separation showed a normal transient. Since the measured vibration spectrum was mostly in the high frequency range, the vibration levels were not considered critical.

MR-1A encountered a 13-minute hold at T-200 minutes to change the capsule high pressure line and 100-minute hold at T-60 minutes to replace an attitude control nozzle in the capsule. Due to the length of this latter hold the countdown was recycled to T-120 minutes.

8.2.3 FLIGHT MR-2

On 31 January 1961, MR-2 was launched at 1154 EST from Cape Canaveral and successfully placed into space a 37-pound male chimpanzee, named Ham. This was the first flight test of the capsule's life support system and the first flight to carry a primate into space. The launch was successful, but the capsule, programmed to travel 114 miles high and 291 miles downrange, traveled 42 miles higher into space and 124 miles farther downrange than planned. Despite re-entry forces up to 15 g's as well as a 6.5-minute period of weightlessness, Ham performed his tasks throughout the flight and survived in excellent condition. The capsule and its passenger were recovered approximately three hours after landing in the sea.

Analysis of the flight revealed that the mixture ratio servo control valve failed in the full-open position causing early depletion of the LOX. The propellant consumption rate was also increased by hydrogen peroxide pressure which drove the turbopump faster. Both conditions resulted in high thrust, early shutdown, and an inadvertent capsule abort.

The abort was due to timing within the abort sensing system. The abort pressure switches were timed to be transferred from the abort mode to the normal shutdown mode at 137.5 seconds. This was 5 seconds before normal expected shutdown. However, the early depletion of LOX shuts down the engine at 137 seconds, one-half second before the pressure switches were transferred. Thus, the decrease in chamber pressure was interpreted as a malfunction, and the abort sensing system signaled abort. To correct the problem on the remaining flights the abort chamber pressure sensors were switched to the normal shutdown mode at 135 seconds, 2.5 seconds earlier than before.

At shutdown the vehicle had a velocity 659 fps above normal due to the higher thrust. To this was added 492 fps gained from the firing of the abort rockets. During the abort the retro rockets were properly jettisoned, but these would have remained attached to the capsule during a normal flight and decreased its velocity by 460 fps. Thus, the capsule had a velocity 1611 fps higher than normal, resulting in the extensive departure from the planned trajectory.

Analysis of the mixture ratio servo control valve showed that movement from the 100 percent open position occurred three times and that the valve probably did not stabilize at a somewhat closed position as a result of (1) a gas leak in the transducer sensing line, (2) icing in the transducer sensing line, and/or (3) shifting of the null setting. The higher than expected hydrogen peroxide tank pressure was probably due to pressure regulator tolerance which was ± 5 percent in the 0 to 600 psig range (or ± 30 psi). Since this is normally acceptable no changes were made in the regulator setting.

All measured data from the abort system sensors, except for the chamber pressure which gave the actual abort, showed levels below the abort limits. As expected, the pitch attitude abort limit of 5 degrees was reached approximately 8 seconds after engine cutoff.

The space vehicle was properly controlled throughout powered flight. The profile varied less than 3 degrees below the pitch program and was 1 degree above the expected final angle of 40 degrees. Structural oscillations of the second bending mode were still present in pitch and yaw during power flight. The maximum amplitude occurring from 100 to 135 seconds, was 0.35 degree per second and represented a nose deflection of 0.02 inch.

The measured deflection of vane No. 1 was approximately 0.8 degree during the period of 125 to 135 seconds.

A narrow band analysis was made of the lateral and longitudinal vibration measurements and the resulting spectra indicated high frequency levels, and, therefore, were probably of aerodynamic origin. The lateral measurement on the capsule mounting ring gave a maximum level at $T + 1.5$ seconds due to ignition and liftoff, but the level was beyond the setting of the sensor. The vibrations decreased to a negligible magnitude until 22 seconds then began a gradual buildup to another maximum between 70 and 80 seconds, to a saturated level, then decreased to a negligible magnitude at 125 seconds and remained at this level until cutoff and separation where it showed a normal transient. The longitudinal measurement on the LEV-3 platform which had previously been mounted on the rate switch bracket, indicated a sharp increase in vibration level immediately after ignition and during the liftoff phase. At 1.5 seconds a maximum over-all value of 4.7 g's occurred and then the level decreased to an insignificant value at 5 seconds. At 25 seconds, the level gradually increased until it reached a maximum saturated value at about 70 seconds. The vibration then became negligible at 110 seconds where it remained until 138 seconds when it showed a normal cutoff and separation transient.

The vibration analysis described above was necessary to evaluate the interaction effects between the vehicle's second bending mode and the control system. The control system had been successfully used on the REDSTONE and thus was selected for the MERCURY flights. However, due to the increased vehicle length and heavier payload, the natural bending frequency of the MERCURY-REDSTONE decreased by a factor of four. This made the second bending mode frequency critical with respect to the stability frequency of the control system. Figure 8-3 shows these vibrations as recorded on a strip recorder. The solution to this problem was the addition of a filter network in the control computer. This filter reduced the control loop gain between 6 and 10 cps, the frequency of the second bending mode.

Flight MR-2 was composed of the MR-2 launch vehicle and Capsule No. 5. The launch vehicle tank section was distorted by unequal pressure during air transport because the tarpaulin plugged the breather vent; the launch vehicle was immediately returned to MSFC where it was partially corrected for geometry and thoroughly checked for structural adequacy, including X-ray inspection of welds. Everything having been found acceptable, the launch vehicle was returned to the Cape. The launch vehicle and

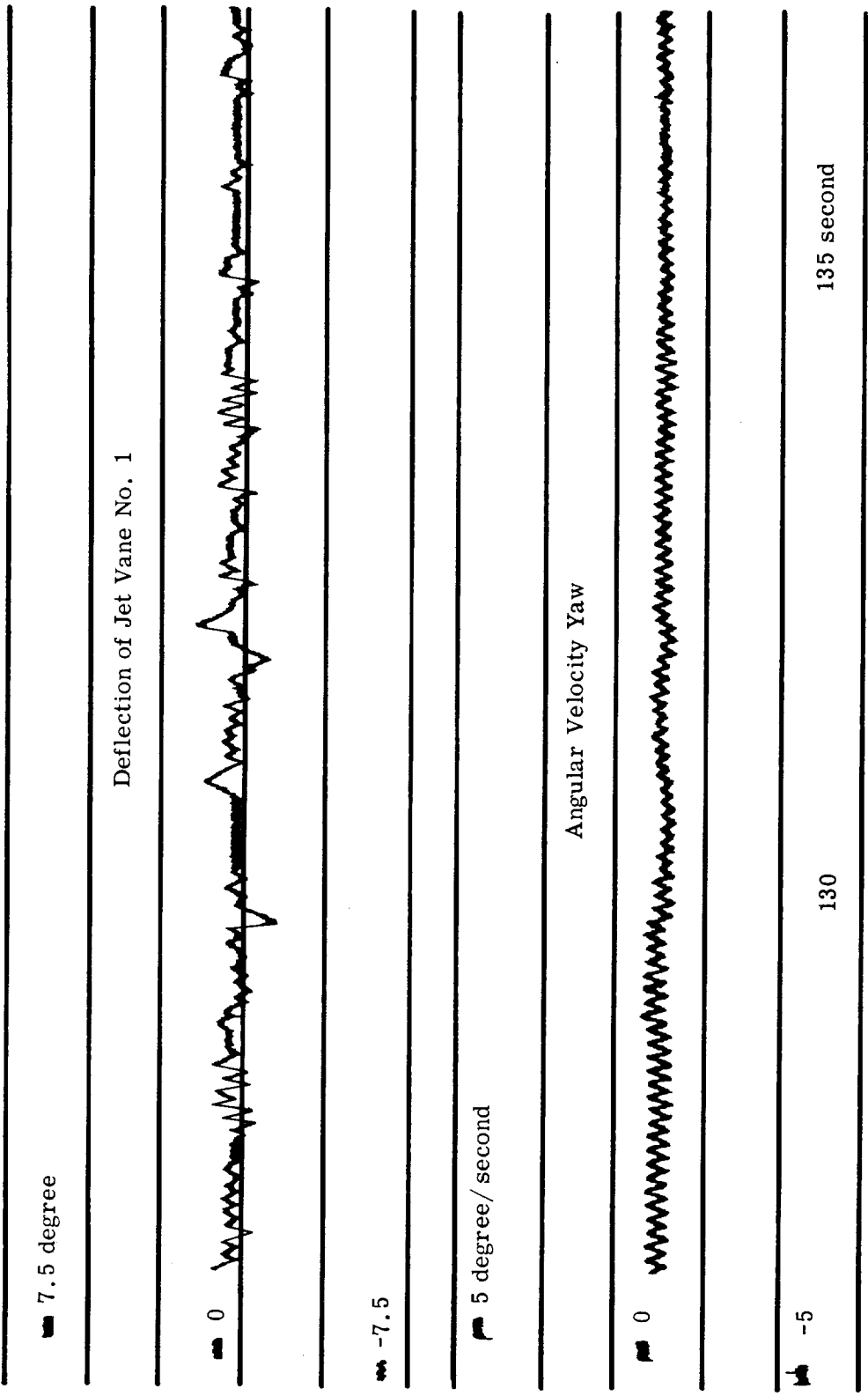

Figure 8-3. Second Bending Mode Oscillations in Yaw Toward End of MR-1A Flight

the capsule were mated on 19 January 1961, and the simulated flight test was conducted on 27 January 1961. A divided countdown was again used to minimize fatigue of the launch personnel. The first part was conducted from 0630 to 1040 EST on 30 January 1961. The second part was started at 0130 EST the following day with a total of 3 hours and 55 minutes hold and recycle time due mainly to resetting the torsion spring on the tail control plug cap of the launch vehicle and to cool the capsule inverter. The holds were as follows:

- At T-260 minutes, 13 minutes - To catch up on vehicle work (8 minutes) and complete tuneup of range command system (5 minutes).
- At T-230 minutes, 17 minutes - By the range to recheck S-band radar.
- At T-170 minutes, 6 minutes - To remove nonessential personnel from pad.
- At T-35 minutes, 66 minutes - To catch up on vehicle work and to reset the tension spring on the launch vehicle tail control-plug cap.

On the afternoon of the MR-1 launch attempt, officials of AMR suggested that substitute trajectories be looked into for the launch of the second MERCURY-REDSTONE flight. The reasons for this were that the REDSTONE trajectory was too steep a flight over land for uprange safety and that the 105 degrees azimuth was very close to the right impact limit line established by the range. The allowances necessary in the selection of the destruct lines were different in the case of the MERCURY vehicle since the vehicle had different velocity vector turning rates and different aerodynamic characteristics. It was suggested that the MERCURY-REDSTONE trajectory be changed to one which was flatter during the propelled flight and that the azimuth be changed to 102 degrees. The trajectory for MR-1A was the same as the MR-1 trajectory. Not until the MR-2 flight, did the above changes become active.

8.2.4 THE MR-BOOSTER DEVELOPMENT FLIGHT (MR-BD)

The first three MERCURY-REDSTONE vehicles were launched within a 10-week period. As expected, they uncovered several problems and weak areas in the design. For each of the problems and design weaknesses a solution had been developed. Several of these solutions, but not all, had been tested in flight.

The original schedule called for the fourth flight to be manned; however, a doubt existed with some of the program personnel whether all the "fixes" would work. A decision had to be made at this point whether to follow the schedule or to launch another

test vehicle. This decision was to be a joint decision based on the recommendations from MSFC, STG, and NASA headquarters. MSFC was requested to make a technical recommendation regarding the booster's readiness to fly with a manned payload. Within MSFC, the design divisions were requested to appraise the vehicle. The appraisal was to consider vehicle reliability, all areas of possible failure, and trajectories.

An estimated trend of mission reliability was developed based on all research and development, tactical REDSTONE, JUPITER-C, and previous MERCURY-REDSTONE launches. A second estimate was made based on the numerical range of probability to achieve the booster mission with the MERCURY configuration as composed of "known and flown" subsystems. The probability of booster success, thus estimated by both methods was between 78 percent and 84 percent at a 75 percent confidence level (see paragraph 5.3.2).

Each division prepared a failure appraisal covering past malfunctions, corrective actions taken, and the expected repeatability of probable malfunctions. Special emphasis was placed on the areas which were considered weak spots in the systems. Corrective actions, if any, to correct these weak spots were also recommended. In the areas of structures, propulsion, control, test, quality assurance, and launch operations, a list was prepared of those items which might contribute to future booster failures. This list, Table 8-3, included both components needing attention and procedures and practices requiring improvement.

The Aeroballistics Division reviewed the trajectories with regard to the way in which the mission's performance could be reduced to a more conservative level and still meet the mission requirements specified by STG at the beginning of the program. A trajectory giving the required 5-minute weightlessness but with an 8 g re-entry deceleration was proposed. This trajectory included, for astronaut safety, a shallow powered phase which allowed water impact near the Cape in the event of an abort. This trajectory was rejected by STG and in the end the original trajectory with 5 minutes of weightlessness and 11 g re-entry forces was used for all remaining flights.

Table 8-3

MERCURY-REDSTONE Priority List of Weak Spots
 (Includes Appraisals from all Divisions and Project Offices)

	<u>Priority Points</u>	<u>Action Being Taken</u>
a. First Priority List (Components)		
(1) Thrust controller	27.7	S
(2) Vibrations	20.0	S
(3) Cutoff arming timer	16.7	S
(4) Abort Sensors	15.0	S
(5) Hydrogen peroxide regulator (tank pressure)	8.2	S
(6) Hydrogen peroxide system cleanliness	7.5	*
(7) LOX manhole leak	5.6	S
b. Second Priority List (Components) (5 points or less)		
(1) Velocity integrator	3.0	*
(2) Instrument compartment pressure	3.0	X
(3) Control relay box	2.5	X
(4) Inverter	2.2	X
(5) Vane nulling if failure	2.1	X
c. Procedures (no priority order)		
(1) Emergency egress (Cape)		S
(2) Personnel fatigue (Cape)		S
(3) Handling and packaging		S
(4) Cleaning procedures		*
(5) Schedules interference (Cape)		S
(6) TEL 3 - blockhouse communications (Cape)		S
Action Code: S = under study on 15 February 1961		
X = no action taken		
* = corrected		
Priority points = number of listings/average priority		

After evaluating the appraisals in Table 8-3, MSFC decided that one additional development flight was necessary. The manned flight was necessary. The manned flight was rescheduled and MR-BD (booster development) was prepared for the next MERCURY-REDSTONE launching.

Flight MR-BD was launched at 1230 EST on 24 March 1961. The booster successfully met its objectives and qualified the changes made in the launch vehicle systems. These changes included the following:

- A control computer filter network was added to reduce the attitude gyro gains from 40 to 160 in the frequency range of the two vehicle bending modes.
- Four stiffeners were added in the ballast section to provide frequency and amplitude dampening.
- The thrust control servo valve closed position was adjusted from 0 to 25 percent open to insure a safe liftoff. During flight the controller performed satisfactorily and always compensated for variations in peroxide tank pressure.
- The hydrogen peroxide regulator was set at 570 psig outlet pressure, down from 590, to prevent over-pressurization of the steam to the turbopump. The pressure monitor range was increased from 600 to 700 psig and a blockhouse monitor installed. A drift limit was established at + 50, - 20 psi.
- The thrust computer and P_c transducer surge suppressor in the engine bay were protected from LOX leaks by the addition of shields and from heat by the installation of insulation.
- Flight sequencer timing changes were made to prevent the abort experienced on MR-2. These included separation of the velocity cutoff arming signal from the signal which caused switchover of the chamber pressure switches from abort to depletion (normal shutdown) mode. Timer changes were as follows:
 - a. 129.5 seconds - Arm normal cutoff signal to capsule (was 136 seconds).
 - b. 131 seconds - Arm velocity cutoff (was 137.5 seconds).
 - c. 135 seconds - Shift P_c switches from abort to depletion mode (was 137.5 seconds).
 - d. 145 seconds - Timer cutoff (was 143 seconds).
 - e. Normal expected cutoff remained at 142.5 seconds.
- The roll rate abort sensor was removed from the abort circuit to preclude inadvertent abort due to high roll rates. Roll rate was not hazardous in itself, and the sensor was used only as a redundant backup for the roll angle

sensor. The roll rate was higher than on earlier flights but was less than half of the 12 degree per second abort limit used on the first three flights.

A special experiment was also conducted on MR-BD. This involved a control maneuver to evaluate the effect of higher than normal angles of attack. This control maneuver consisted of a temporary tilt arrest at 20 degrees from vertical for 8 seconds at 78 seconds flight time (Q max). This built up angle of attack to 2.30 degrees. Subsequent prolonged tilting brought the missile back to its programmed flight profile with negligible deviations. The experiment proved that the vehicle could withstand the additional loads and its systems.

To instrument MR-BD's special experiment two jet vanes, position indicators, a P_c sensor, and the capsule mounting ring-lateral, vibration monitor were put on straight channels. The thrust controller error signal output was added to the commutated channel and the abort sensors were commutated.

During flight, low frequency lateral vibrations were again present in the instrument compartment and closely approximated the second bending mode of the vehicle. The maximum vibration occurred during the period of transonic speed, which occurred approximately 70 seconds after liftoff. The capsule mounting ring vibrations monitor, although increased in range, was still insufficient to sense the entire frequency range of vibrations. Vane vibrations were not experienced, and, therefore, it was assumed that the filter network was completely satisfactory.

The television camera was removed from MR-BD to save the hardware for the MR-4 flight.

The capsule attached to MR-BD was a boilerplate. It had equivalent weight, mass distribution, and aerodynamic and bending characteristics of the actual capsule. There was no electrical interface, abort capability or separation, but a breakwire was installed to indicate an inadvertent separation if it occurred (which it did not).

During the countdown additional telemetry checks were made. No holds occurred, but some LOX overflow was experienced during topping. This was caused by sloshing due to 15 to 20 mph winds at launch. Also a 119 knot jetstream at 41,000 feet caused the vehicle to impact approximately 6.2 miles further downrange than anticipated.

8.3 MANNED FLIGHTS

8.3.1 FLIGHT MR-3

On 4 May 1961 at 0934 EST the United States' first astronaut, Alan B. Shepard, was successfully launched into space in a ballistic trajectory which included 5 minutes of weightlessness (Figure 8-4). All mission objectives were accomplished and no malfunctions occurred. The flight occurred three days after the initial attempt was postponed due to severe weather in the recovery area.

MR-3 consisted of booster MR-7 and the Freedom 7 capsule (Figure 8-5). The split countdown was used, with the first part completed on 4 May, and the second portion resumed at 0300 EST on 5 May.

The booster's propulsion system functioned normally. Cutoff occurred at 141.3 seconds and capsule separation at 141.8 seconds (Figure 8-6). The booster sent the capsule on a flight 115 miles high and 302 miles down the Atlantic Missile Range (Figure 8-7). There was no evidence of second bending mode feedback in the control system. This further proved the effectiveness of the filter network incorporated after the MR-2 flight test. Although Astronaut Shepard reported buffeting during powered flight, telemetry data indicated that the vibration levels were lower than those of flights MR-2 and MR-BD. Prior to the flight, 330 pounds of dampening material was added along with 14 stringers in the ballast unit. These decreased the vibrations; however, it was decided to add more dampening material to the instrument compartment of the next flight booster (MR-4).

Two vibration transducers were installed in the aft unit. Measurement 901, on the capsule adapter ring, measured vibration in the pitch plane perpendicular to the longitudinal axis of the vehicle. Measurement 906, mounted on the LEV-3 support bracket, measured vibration in the longitudinal direction. The calibration range of the measurements was ± 30 g's and ± 10 g's, respectively. The major results revealed by a detailed analysis of the vibration data measured during flight were:

- The duration of high vibration levels due to aerodynamic excitation was shorter in MR-3 than in earlier flights with similar trajectories.
- The vibration levels in the instrument compartment were distinctly lower than in earlier flights.



Figure 8-4. Liftoff of MERCURY-REDSTONE MR-3

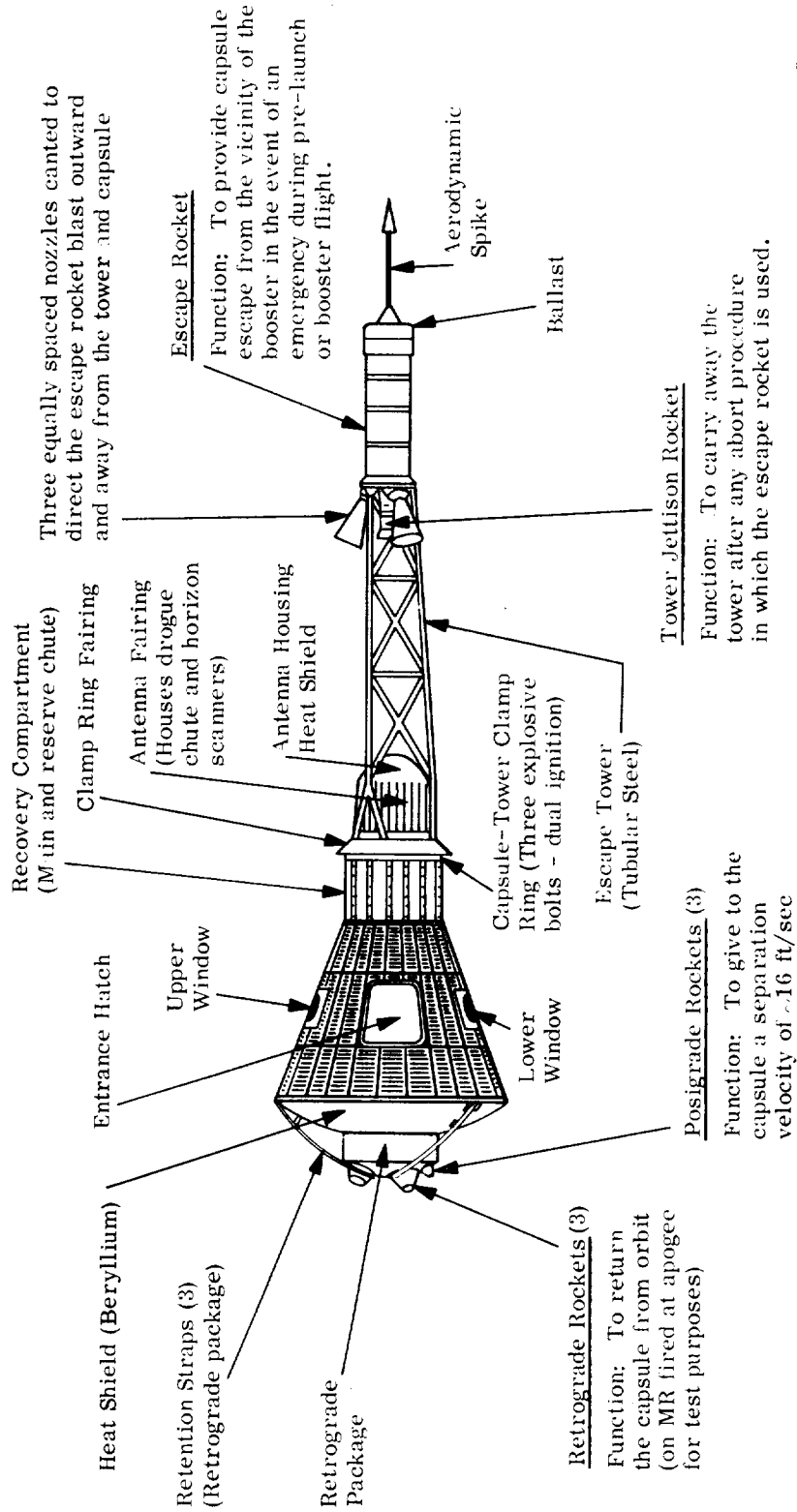

Figure 8-5. MERCURY-REDSTONE MR-3 Capsule Configuration (Capsule No. 7)

- There was a definite 33 cps oscillation in the longitudinal direction at approximately 70 seconds.
- The vehicle was oscillating predominantly in its second-body bending mode throughout the flight.

The launch vehicle shut down properly and capsule separation occurred as expected (Figure 8-8). Astronaut Shepard then assumed manual control of one axis at a time (pitch, yaw, and roll, in that order), and then controlled the vehicle throughout the retro-fire maneuver. Shepard demonstrated that man could control his vehicle both during five minutes of weightlessness and under acceleration loads up to 11 g's. Sensors attached to his body relayed his heart beat and respiration rate to doctors in the control center. During the flight the astronaut maintained radio communications with the control center at the Cape.

After a flight of 13 minutes and 7 seconds, the capsule impacted in the sea three nautical miles from the calculated point. The astronaut and the capsule were recovered by helicopter within six minutes of landing and both were aboard the USS Lake Champlain within eleven minutes.

Seven holds were called during the countdown as follows:

- T-265 minutes, 10.50 minutes to clear the pad for RF checks.
(T-140 minutes, the normal 60 minutes hold at this point was shortened to 49.50 minutes to catch up on the count.)
- T-120 minutes, 20 minutes to complete capsule work.
- T-80 minutes, 7 minutes to complete capsule work.
- T-30 minutes, 1 minute to clear the pad.
- T-15 minutes, 34 minutes to evaluate the weather situation and check the booster inverter power supply which drifted out of tolerance. The hold was continued to 52 minutes to replace the inverter.
- T-15 minutes, 17.5 minutes for a computer program check between Goddard and the MERCURY Control Center.
- T-2.66 minutes, 1 minute to decrease the fuel pressure. The fuel vent was cycled several times until regulated pressure returned and stayed normal.

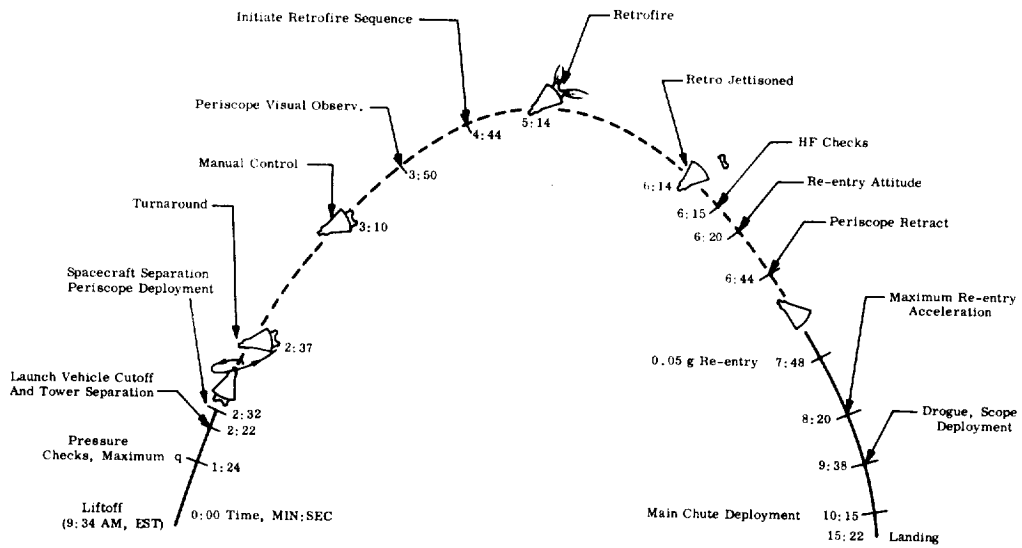

Figure 8-6. MERCURY-REDSTONE MR-3 Flight

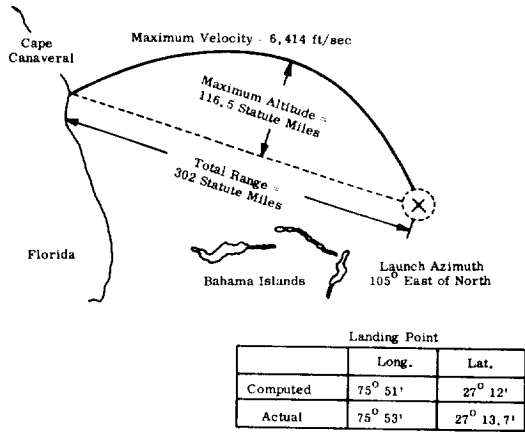

Figure 8-7. MERCURY-REDSTONE MR-3 Ground Track and Flight Profile

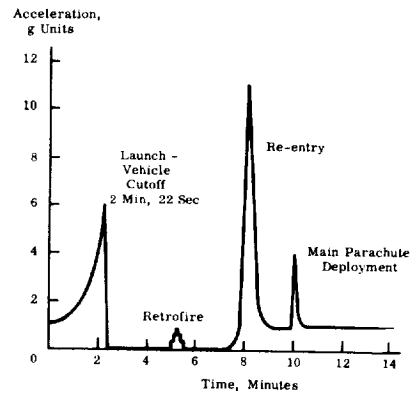

Figure 8-8. MERCURY-REDSTONE MR-3 Acceleration Profile

8.3.2 FLIGHT MR-4

Flight MR-4 successfully carried Astronaut Virgil I. Grissom in Liberty Bell 7 on the second manned MERCURY ballistic space mission. Liftoff was at 0720 EST on 21 July 1961 (Figure 8-9). Again all booster systems performed perfectly and all vehicle goals were met.

As with MR-3, the mission objectives were to:

- Familiarize man with a brief but complete flight experience, including liftoff, powered flight, 5 minutes of weightlessness, re-entry, and landing.
- Evaluate man's ability to perform as a functional unit during space flight.
- Collect aeromedical data.
- Safely recover the astronaut.
- Safely recover the capsule.
- Provide training for ground support and recovery forces.

All objectives but capsule recovery were fully met. The capsule was lost when helicopter pickup was unsuccessful due to the increased weight caused by water which had entered capsule after the side egress hatch prematurely opened.

No complaints of vibration were expressed by Astronaut Grissom, indicating the effectiveness of additional 102 pounds of dampening compound added to the ballast unit.

After the MR-3 flight, the scheduled 60 minute built-in hold was advanced to T-180 minutes instead of T-120 minutes. This change was made to provide the latest possible weather forecast prior to LOX loading. If a favorable forecast, having a validity of 90 percent, could not be determined, LOX loading operations would not have commenced. This procedure (by not LOXing) provided an alternate by 24 hours scheduling.

The first launch attempt on 18 July 1961, had no holds, however, the flight was scrubbed due to unfavorable photographic weather conditions.

The second attempt was made on 19 July. At T-130 minutes, a 30-minute hold was made to complete checkout of capsule equipment. A 9-minute hold at T-60 minutes was required to complete additional capsule work. At T-10.6 minutes a 91-minute hold for better cloud conditions resulted in a scrubbed flight.

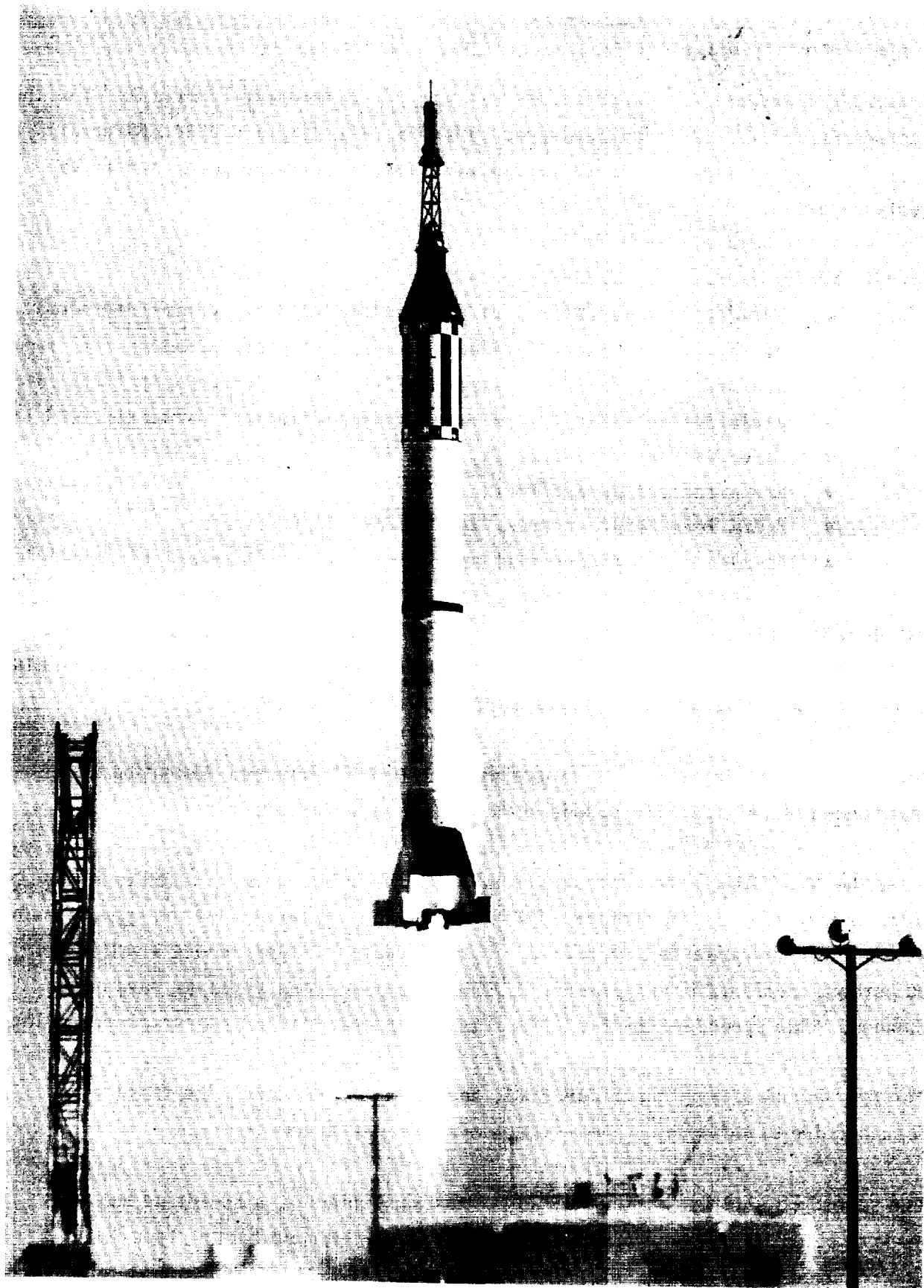

Figure 8-9. Liftoff of MERCURY-REDSTONE MR-4

The third and successful attempt on 21 July had 3 holds of 80 minutes total duration. At T-45 minutes, a 30-minute hold was necessary to permit capsule personnel to complete capsule work. At T-30 minutes, a 9-minute hold permitted the searchlight crew to secure the searchlights because of interference with telemetry receiving equipment in the blockhouse. Finally, at T-15 minutes a 41-minute hold was made to await more favorable optical conditions for the long focal-length cameras.

Figure 8-10 indicates the flight profile. Note that the launch azimuth was changed from the 102 degrees used for MR-2, BD, and 3 to 100 degrees east of north. This change was required because calculations after the MR-3 flight indicated that MERCURY-REDSTONE three-sigma guidance deviations could cause a malfunctioning booster to endanger the Bahama Islands. A comparison of the flight parameters of MR-4 and MR-3 spacecraft, listed in Table 8-4, shows that both flights provided similar conditions.

The acceleration time history occurring during the MR-4 flight is shown in Figure 8-11 and is very similar to that of the MR-3 flight.

The recovery force deployment and spacecraft landing point are shown in Figure 8-12. The spacecraft was lost during the postlanding recovery period as a result of premature actuation of the explosively actuated side egress hatch. The astronaut egressed from the spacecraft immediately after hatch actuation and was retrieved after being in the water for about 3 to 4 minutes.

MR-4 brought to an end the ballistic series of MERCURY flights. Program success permitted the cancellation of two additionally planned MERCURY-REDSTONE flights, and the program moved forward to the orbital flights with the ATLAS booster.

Table 8-4

Comparison of Flight Parameters for MR-3 and MR-4 Spacecraft

Parameter	MR-3 Flight	MR-4 Flight
Range, nautical miles	263.1	262.5
Maximum altitude, nautical miles	101.2	102.8
Maximum exit dynamic pressure, lb/sq ft	586.0	605.5

Table 8-4

Comparison of Flight Parameters for MR-3 and MR-4 Spacecraft (Cont.)

Parameter	MR-3 Flight	MR-4 Flight
Maximum exit longitudinal load factor, g units	6.3	6.3
Maximum re-entry longitudinal load factor, g units	11.0	11.1
Period of weightlessness, min:sec	5:04	5:00
Earth-fixed velocity, at cutoff, ft/sec	6,414	6,618
Space-fixed velocity, at cutoff, ft/sec	7,388	7,580

8.4 OPERATIONAL CHANGES RESULTING FROM FLIGHT TESTING

The new safety and reliability requirements imposed by a manned payload caused many changes in the operational launch procedures. These changes consisted mainly of checkout instructions, flight safety review board actions, instrumentation, and launch control. The general operation and organization of these factors have been described in Section 7. The design modifications resulting from the flight tests are described in paragraph 4.8.2.

During the flight program, the above procedures and operations were modified or changed as further knowledge of the MERCURY-REDSTONE launch vehicle was obtained. MR-1 demonstrated the need for compliance to careful preparation and use of special parts. The launch failure resulted in changes to assure vehicle grounding both through the added ground strap and adjustment of the electrical plug clamp.

MR-2's tank distortion was due to improper securing of the tarpaulin during air transport, a matter easily prevented on the next three vehicles.

A countdown change was made between MR-3 and MR-4 to prevent poor weather from causing a costly and hazardous condition to develop. The change involved moving the 60-minute, built-in hold from T-120 to T-180 minutes. This permitted a recheck of weather conditions and a longer hold, if necessary, before LOX loading. If the weather conditions were good and had a 90 percent chance of remaining favorable, then LOX loading would proceed.

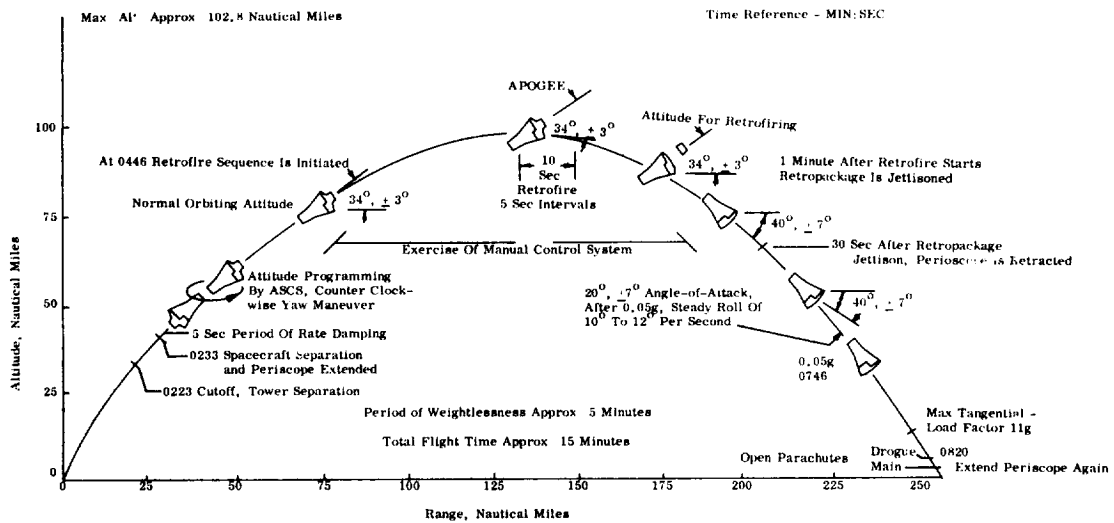

Figure 8-10. Flight Profile for MR-4

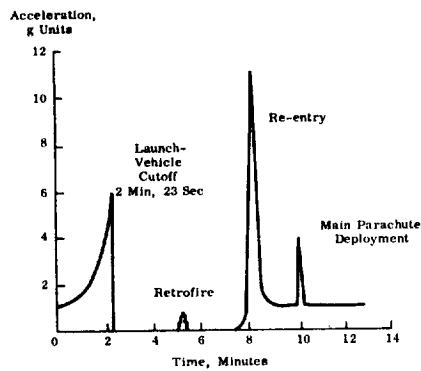

Figure 8-11. Acceleration Time History for MR-4 Flight

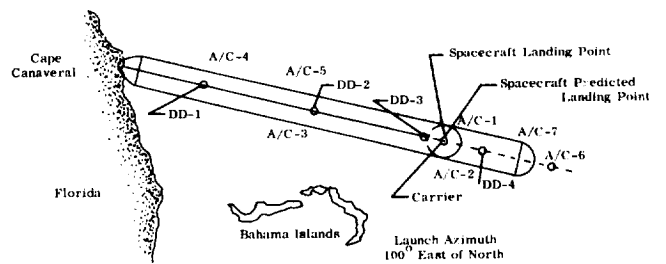

Figure 8-12. Chart of Recovery Operations

Examinations of the launch schedule and vehicle preparations, as described above, improved both crew safety and vehicle reliability. They contributed to the success of the MERCURY-REDSTONE Program and should serve as guidelines for future space efforts.

SECTION 9

CONTRIBUTIONS TO MANNED LAUNCH VEHICLES

9.1 INTRODUCTION

The preceding sections of this report have, in the course of describing the development of the MERCURY-REDSTONE launch vehicle, presented many items which represent major innovations required for the first manned flight and which are still appropriate for manned systems. As stated at the beginning of the report, our major purpose was not to present a mere record of occurrences, but to identify and highlight the lessons to be learned from a review of the complete program (both its failures and successes) which would be of value to the development of future manned launch vehicles. It is to this purpose that Section 9 is addressed. The contributions that the MERCURY-REDSTONE Program made to manned launch vehicle development are discussed under four main categories: man-rating, design, testing, and operations.

9.2 MAN-RATING

9.2.1 GENERAL

In regard to man-rating, there are a few remarks which, while not specifically related to the design of the booster, do have an important impact on any manned project. They are concerned with the question, "When is a vehicle man-rated?" In the original program schedule, the third flight of the series and those following were to be manned. This was predicated, however, on successful completion of the first two flights. While this may seem to be quite an early introduction of man, it should be noted that over 60 unmanned REDSTONE missiles had flown in other military and space research programs prior to that flight. In addition, experimental rocket aircraft had included man with the first flight of the prototype. Since, in future launch vehicles of the SATURN class, it is quite impractical to consider launching 60 boosters prior to the introduction of man, it is vital that the first manned flight take place as early as possible in the development program. In general, many groups of planners have sought the answer to this question in terms of numerical values of reliability and confidence level; however, such criteria inevitably lead to requirements for an economically unfeasible number of unmanned flights. The MERCURY-REDSTONE project team also made such analyses. However, manned flight was not approved until the launch vehicle

had demonstrated, in actual flight, its capability to perform all required functions properly. This latter criteria resulted in the manned flight being delayed until the fifth launch attempt, rather than the third, because of failures occurring in two earlier launches (MR-1 and MR-2). Delaying the introduction of man because of these failures did not result in a lengthy delay in the program and is probably justified on the basis of the qualitative increase in confidence achieved with the additional launches and the relatively small increment in time and cost incurred.

In summary then, it would appear that it is qualitative, not quantitative confidence, that determines when a launch vehicle is ready for manned flight. In support of this argument is the fact of the admittedly low quantitative confidence level which must have been associated with including a man on the first rocket aircraft flights. The MERCURY-REDSTONE was able to satisfy this criteria within reasonable constraints of time and cost; however, the flight program history clearly indicates a need for comprehensive analysis of flight schedules, including the introduction of man, with failure contingencies taken into account. As launch vehicles approach and perhaps exceed the cost of a SATURN V, it becomes imperative to determine well in advance of the first flight, what action can be taken to reduce the requirement for additional launches, prior to manned flight, in the event of a booster failure. Future programs will be efficient and timely only if we resolve a means for obtaining this intrinsic, qualitative confidence level without resorting to an additional unmanned launch each time a failure occurs. A thorough understanding of failure effects through ground testing and analytical studies is but one of the means to achieve that goal. Other items include flight safety (abort) systems to accommodate failures and detailed quality assurance programs such as were developed for MERCURY-REDSTONE.

When is a launch vehicle man-rated? When its developers have a high, but qualitative confidence that it will perform all of its functions properly and, in the improbable event of an inflight failure, safety of the crew will be assured with an abort sensing and implementation system. Ultimately, this confidence will be achieved, as with rocket aircraft presently, prior to the first full scale launch attempt.

The MERCURY-REDSTONE was the first man-rated rocket launch vehicle. There existed the unique opportunity and responsibility to investigate and provide both vehicle reliability and crew safety. Although crew safety is highly dependent on vehicle reliability, the term, crew safety, is used here to distinguish those elements of the vehicle design and operations that enhanced the astronaut's probability of a successful

recovery in the event of a failure. MERCURY-REDSTONE's contribution to these aspects of man-rating are described in the following paragraphs.

9.2.2 CREW SAFETY

The greatest single item added to the MERCURY-REDSTONE, which improved crew safety, was the automatic inflight abort sensing system. Automatic abort systems have also been used on the MERCURY-ATLAS. A combination of automatic and manual systems is planned for the SATURN.

In determining which parameters the abort sensing system should monitor in order to identify vehicle failures as rapidly and safely as possible, the MERCURY-REDSTONE designers faced perplexing alternatives. As the number of parameters increased, the probability of correctly identifying the cause of a failure also increased, and, in addition, the time between the first failure indication and vehicle destruction would increase, permitting more time for safe astronaut ejection. However, as a consequence of monitoring more parameters, the sensing system complexity also increases, thereby increasing the probability of its failure which could lead either to a falsely aborted mission or an astronaut fatality.

The design team elected to monitor as few parameters as possible to reduce the probability of a false abort and develop a simple system of high reliability. The reduced time between the first failure indication and vehicle destruction was accommodated by an automatic abort implementation system. Since all vehicle component or subsystem failures which may affect the mission completion or astronaut safety eventually lead to measurable changes in vehicle performance, those performance parameters were selected which would give the earliest indication of a failure, coupled with engine chamber pressure and electric power as two subsystems whose performance affected or was affected by a majority of the other vehicle subsystems.

The selection of abort sensing parameters and the establishment of their limits remains as one of the major problems confronting the designers of manned launch vehicles. The criteria developed by the MERCURY-REDSTONE team and the specific parameters they selected have turned out to be of major value and guidance to other launch vehicle programs such as ATLAS and SATURN. The inter-relationship of the abort parameters monitored and the mode of abort (manual or automatic) was also recognized at this early date, increasing the validity of the design which was eventually employed on the MERCURY-REDSTONE launch vehicle.

Since the abort system was totally new at the time of the MERCURY-REDSTONE design, many guidelines were established. The abort system had to be tailored to the vehicle, utilize existing hardware, if possible, and sense only those parameters that were easily and reliably measured commensurate with the probable failure modes. Reliability of the system was stressed in hardware selection, test, and modes of operation. Additional details of the first abort system are given in Section 5.

It is important to note that an automatic system was chosen because it was felt the astronaut could not respond quickly enough to the emergency conditions possible with the REDSTONE booster. Only the GEMINI manual abort system deviates from this basic criterion due to the GEMINI's propellant combination which has a low probability of explosion.

The automatic inflight abort sensing system also established basic ground rules for abort sensing parameters and sensors. Three basic abort parameters recognized as essential for crew safety by each manned launch vehicle project are propellant pressure, vehicle attitude rates of change, and electrical voltage (power). The MERCURY-REDSTONE design recognized that these three parameters provided monitoring of the effects of nearly all possible component and system failures. To these were added other abort parameters designed to monitor specific failure modes.

The sensors used to measure the abort parameters were to have both positive and negative redundancy; that is, the system had to be designed to assure an abort when an abort was required, and yet also assure the improbability of a false abort. Use of redundant sensors and redundant parameters gave this assurance to MERCURY-REDSTONE and MERCURY-ATLAS. This same philosophy is being applied to the GEMINI and SATURN.

The automatic inflight abort sensing system sent a signal to the capsule which activated the engine shutdown, capsule separation, and abort tower ignition systems. This sequencing could also be initiated by the astronaut, the launch director, and the MERCURY Control Center (see paragraph 5.2). To assure astronaut and range safety, the abort command inputs were armed at various times in the countdown and flight. Similar initiators of the abort signal and similar sequencing of their abort signal input are also features of all other manned launch vehicles.

9.2.3 VEHICLE RELIABILITY

The abort sensing system described above provided crew safety in the event of a hazardous failure. However, a catastrophic failure never occurred with the MERCURY-REDSTONE, thus indicating the successful efforts of man-rating the basic vehicle systems to provide a reliable booster flight.

The high quality of the design, manufacture, test, and checkout of the vehicle contributed to the near-perfect reliability of the MERCURY-REDSTONE. Achieving this level of quality, however, was not based on normal levels of effort. Rather, better performance from each individual in the booster program was gained through a highly motivating MERCURY Awareness Program.

This program used publicity, awards, and symbols to emphasize the importance of the individual contributor in achieving reliability. MERCURY stamps placed on MERCURY-REDSTONE documents and manned vehicle hardware continuously called attention to the fact that the astronauts' lives depended on high reliability. This program proved its effectiveness and has been duplicated in all other manned launch vehicle and payload programs.

9.3 DESIGN

9.3.1 GENERAL

The changes and modifications made to the tactical missile contributed significantly to man-rating the MERCURY-REDSTONE and to the development of methods for designing future manned launch vehicles. The following changes and their effect on the man-rated MERCURY-REDSTONE are presented as they apply to the major vehicle systems. This examination of the resulting systems and the reasons for their design thus leads to guidelines for future manned vehicle design.

9.3.2 PROPULSION

The first major decision regarding the propulsion system was changing to the A-7 engine at the beginning of the program to avoid a change midway through the manned vehicle development. This avoided confusion and the resulting human errors by eliminating change orders, hardware substitution, and procedural revisions.

The propellant prevalves isolated the propellant tanks from the engine system prior to launch and served no function once the engines were started. Since they could fail-closed during burning and thus initiate a false shutdown and abort, they created an unnecessary hazard. The ATLAS, TITAN, and SATURN engine systems for manned payloads have also deleted the prevalves from flight use.

Propellant explosive and toxic properties must be considered in manned launch vehicle design. The MERCURY-REDSTONE used ethyl alcohol and LOX. This combination was well known to designers and fuel handlers and thus presented no new problems. The toxicity of Hydine, which was used on the JUPITER-C, was considered unsafe for the astronaut in the event of a pad abort or a prelaunch emergency egress.

Manned flights present the problem of longer than usual holds to make sure everything is A-Okay. Long holds, however, mean a greater chilldown of the LOX lines and the total engine system. This can result in hazardous freezeups. MERCURY-REDSTONE brought this problem to the designers' attention and required fuel line bubbling, extra instrument insulation, and heater jackets for the chamber pressure sensor lines. These system features are also being used on SATURN.

Long holds also required an accurate LOX fill and "topping" system to assure meeting flight requirements. Special sensors and a computer were added to the propellant loading system.

Leakage of propellants into the engine bay could cause an accumulation of an explosive mixture. To minimize this danger the area was purged with nitrogen prior to liftoff and new seal materials were used in the hydrogen peroxide system. This safety requirement has also been imposed upon the SATURN.

9.3.3 STRUCTURES

Although the basic REDSTONE in the JUPITER-C configuration was used, a new aft section was necessary to provide the compartment space necessary for the guidance, control, and communication systems. The design of this section followed a design rule established then by MSFC which has been used on the SATURN. The rule states "the structure shall be self-supporting under all expected loads without internal pressure stabilization." To obtain maximum performance with safety, the tank walls varied in thickness consistent with the 1.35 factor of safety and the anticipated loads.

Prior to MERCURY-REDSTONE, the payload-vehicle interface was the dual responsibility of both prime contractors. However, to assure a safe separation and to place single responsibility for the separation on one agency and contractor, the MERCURY-REDSTONE's separation plane was totally contained within the adapter section, and the capsule contractor was given responsibility for this section. The vehicle-adapter mechanical interface then became a simple flange and bolt circle.

9.3.4 GUIDANCE AND CONTROL

Manned flight required the guidance to be simple and reliable; therefore, MERCURY-REDSTONE's guidance was a well-tested autopilot. During first stage burning, the SATURN also uses a simple autopilot. This design rule enhances crew safety in the relatively hazardous pad and maximum dynamic pressure regions of flight.

9.3.5 DESTRUCT SYSTEM AND RANGE SAFETY

The range safety fuel dispersion (destruct) system was modified by the addition of a destruct delay. This time delay would have permitted abort of the capsule to a safe distance from the booster before destruct explosion. The delay has been incorporated as a safety feature on all manned vehicles since MERCURY-REDSTONE. The MERCURY-REDSTONE also established the need for examination of launch trajectories and guidance accuracy versus range safety boundaries. The destruct delay caused the range safety limits to be proportionately narrowed, but the amount of narrowing was a function of the vehicle and its modes of failure. Hence manned launch vehicles require coordination between design and range safety requirements to attain maximum flexibility during launch.

9.3.6 DESIGN CRITERIA

In addition to the specific system design guides, several general design criteria were established during the MERCURY-REDSTONE development. These included the overall design factor of safety of 1.35 and the yield factor of 1.1.

9.4 TESTING

9.4.1 GROUND TESTING

The test program established for the six boosters used in the MERCURY-REDSTONE Program is described in Section 6 of this report. The MERCURY-REDSTONE

experienced the first application on a man-rated vehicle of the pyramidal testing philosophy, whereby components, subsystems, and then the entire vehicle are functionally checked. This type of testing verified proper operation of all hardware within the vehicle. As part of the prelaunch procedures and checkouts, each of the MERCURY-REDSTONE boosters were scheduled for static firing tests to insure satisfactory performance and reliability under rated thrust conditions. Due to the high degree of reliability under rated thrust conditions. Due to the high degree of reliability necessary for a man carrying vehicle, actual launch and flight conditions were simulated as closely as possible. A total of 32 static tests were conducted on the MERCURY and its test boosters with an accumulated time of over 2,230 seconds.

9.4.2 FLIGHT TESTING

The MERCURY-REDSTONE flight program developed the first man-rated space systems and accomplished the initial objective which was to gain space flight familiarization. The flights and the accomplishments of each toward the ultimate goal of space travel are covered in Section 8 of this report. A particularly significant contribution of the MERCURY-REDSTONE Program to Manned Launch Vehicle development was that the spacecraft was the first to experience the environment and requirements of space flight. Of equal importance to the experience of the astronauts was the invaluable training of the ground crew in the preparation, launching, and the recovery of the first two manned spacecrafts.

9.5 OPERATIONS

As a result of the MERCURY-REDSTONE checkout and launch operations, a number of salient considerations evolved which should be translated into future programs concerned with the launch of manned vehicles. The major considerations are listed as follows:

- Facility requirements must be comprehensively planned at the very inception of a program. Facilities and ground support equipment require as much, and sometimes more lead time than the development period of the first vehicle.
- On-the-pad emergency egress procedures are mandatory in manned space vehicle operations, and they must be considered in the earliest design phase of the complex and space vehicle to provide an optimum system.
- Integration of launch operations under one control point is essential to assure that a feasible, coordinated countdown of reasonable duration will result.

Experience indicated that some degree of automation will help to reduce the countdown period to an acceptable length.

- Serious consideration should be given to improving the reliability of obtaining, presenting, and digesting inflight information.
- Design of the space vehicle should consider test and launch operation requirements at the launch site. Design compatibility should be emphasized in the area of GSE, communications systems, ordnance requirements, emergency conditions, and interface considerations.
- Realistic scheduling is essential throughout a program but should be especially emphasized at the launch site where numerous supporting organizations must participate. Test schedules at the launch site should be coordinated by one central point to assure that precedence, priority, conflicting checkout functions, and other AMR programs are properly coordinated and controlled.
- The complexity of manned launch vehicles and the launch operations dictates that a single point of entry for range support is necessary. This procedure will assure that all NASA problems are coordinated within NASA to prevent conflicting or confusing information from reaching range or contractor personnel.
- Weather restrictions on launch operations must be reduced if critical schedules, such as launch windows, are to be met on an operational basis. Vehicle design should consider this factor in terms of allowable ground and upper-air winds. A study should be initiated to provide a method of optical coverage through the maximum dynamic pressure region which is independent of ground weather conditions.

9.6 CONCLUSION

Throughout this section the phrase "also used in all other manned launch vehicle programs" has been repeated many times. The numerous repetitions indicate the many manned space flight guidelines for future programs which were established by the MERCURY-REDSTONE Program. MERCURY-REDSTONE's opportunity to take the first steps into space has proved to be the making of a solid foundation for manned space travel.

SECTION 10

REFERENCES

This section presents a listing of technical reports and documents related to the MERCURY-REDSTONE Program. The MSFC documents are presented in the sequential order of the launch vehicle flights. For each flight the booster was selected on a basis of highest acceptable test performance; consequently, only flight numbers MR-1 and MR-2 utilized identical booster numbers, MR-1 and MR-2. At the time of selection of a booster for flight MR-1A, booster Number MR-3, had the highest test performance record. The fourth flight, MR-BD, utilized booster MR-5. Boosters MR-4 and MR-6 were not launched. Manned flights MR-3 and MR-4 utilized boosters MR-7 and MR-8, respectively.

By listing the MSFC prepared documents in accordance with the flight numbers, booster MR-3 information is located under MR-1A, booster MR-5 under MR-BD, and MR-7 and MR-9 under flights MR-3 and MR-4, respectively.

GENERAL

AOMC CR-SS-60-6

Satellite and Space Program Progress Report for NASA, 6 July 1960 (C)
(AOMC).

ARS 2238-61

Hammack, Jerome B., Herberlig, Jack C., The MERCURY-REDSTONE Program, 9-15 October 1961 (American Rocket Society).

CHRYSLER CORPORATION MISSILE DIVISION

Chrysler ME-M5

MERCURY-REDSTONE Reliability Test Program (CCMD).

Sommer, D., Vibration Test of the Steam Generator Elbow of the MERCURY-REDSTONE Engine, (CCMD).

Chrysler GLC-R-5

Upton, G.S., MERCURY-REDSTONE Aft Section Test Report, October 1960 (Ground Tests) (CCMD).

Chrysler GLC-M-29	DeBaker, J. L., <u>Final Report for Humidity Test of MRT-1 Aft Section</u> , 15 January 1961 (Ground Tests) (CCMD).
Chrysler SL-M56	Perry, D. G., <u>Combined Vibration and Temperature Environmental Evaluation Tests on the REDSTONE Tail Unit for MERCURY-REDSTONE Missiles</u> , 1 April 1960 (CCMD).
Chrysler SL-M59	Fama, N., and Suddath, J., <u>Structural Reliability Testing of MERCURY-REDSTONE Thrust Unit Reports I and II</u> , 15 April 1960 (CCMD).
Chrysler DSD-TM-12-60	Sorce, Peter S., Van Camp, L., Stevens, R. E., <u>REDSTONE Missile Malfunction Study (MERCURY-REDSTONE Program)</u> , 15 June 1960. (S) (CCMD).
Chrysler ML-M134	Schayer, D. E., <u>Combined Vibration and Temperature Environmental Tests of Mechanical Components for MERCURY-REDSTONE Missiles</u> , 26 April 1960 (CCMD).
Chrysler ML-M135	Torigian, R. M., <u>Reliability Test of the RE 7112 a REDSTONE A-7-1 Rocket Engine</u> , 14 April 1960 (CCMD).

NATIONAL AERONAUTICS AND SPACE ADMINISTRATION

NASA Conference	<u>Results of the First U.S. Manned Sub-orbital Space Flight</u> , 6 June 1961 (NASA).
	<u>Results of the Second U.S. Manned Sub-orbital Space Flight</u> , 21 July 1961 (NASA).
	<u>Abort System Experience and Application to the Design of Advanced Crew Safety Systems</u> (Manned Space Center - NASA).
MSFC MHR-2	<u>MERCURY-REDSTONE Chronology to December 31, 1961</u> May 1961 (Historical Office).
MTP-M-S&M-TSR-60-1	Barraza, R. M., Glover, J. C., <u>MERCURY Booster Recovery</u> , 30 November 1960.
DLMT-TN-28-60	Hildebrand, Arnold G., <u>Evaluation of Flotation and Drop Tests MERCURY-REDSTONE Booster</u> , 25 March 1960

MSFC MTP-AERO-61-69	<u>Clarke, W.G., Preliminary Evaluation of MERCURY-REDSTONE Launch MR-4, 22 August 1961 (C) (AERO).</u>
MSFC MTP-AERO-61-74	<u>Smith, J.W., Atmospheric Environment for the Flight of MERCURY-REDSTONE MR-4, 28 September 1961 (IUO) (AERO).</u>
MSFC MTP-AERO-61-76	<u>Ledford, Harold, Actual Trajectory of MERCURY-REDSTONE Flight Test MR-4, 22 September 1961 (C) (AERO).</u>
MSFC MTP-P&VE-P-61-20	<u>Riquelmy, J.R., King, N.W., Montgomery, J.L., MERCURY-REDSTONE MR-4 Flight and Evaluation of Propulsion Unit and Associated Systems, 9 November 1961 (C) (P&VE).</u>
MSFC MTP-LOD-OIR-61-23.1	<u>Index and Test Results Part I of the Firing Test Report MERCURY-REDSTONE Vehicle MR-4, 15 August 1961 (C) (LOD).</u>
MSFC MTP-LOD-ED-61-23.2b	<u>Hinds, Noble F., Instrumentation Operations Analysis Part IIb at the Firing Test Report MERCURY-REDSTONE MR-4, 24 August 1961 (C) (LOD).</u>
MSFC MTP-LOD-MP-61-23.3	<u>Heezen, Kenneth F., Hill, Lawrence F., Firing Site Weight Report Part III of the Firing Test Report MERCURY-REDSTONE MR-4, 2 August 1961 (C) (LOD).</u>

MTP-M-LOD-DR 60-3	Spencer, Clayton M., <u>MERCURY-REDSTONE Thrust Unit Water Recovery</u> , 26 October 1960.
	Humphrey, John, and Bertram, Emil, <u>Preliminary MERCURY-REDSTONE Booster Recovery Operations at Atlantic Missile Range</u> , 20 May 1960.
NASA SP-45	Kuettner, J. P., Bertram, E. P., <u>MERCURY Project Summary, MERCURY-REDSTONE Launch Development and Performance 1963 (USA)</u> .
	Kuettner, J. P., Bertram, E. P., <u>The Manned Rocket Vehicle MERCURY-REDSTONE</u> , Proceedings of the Twelfth International Astronautical Congress, 1962 (USA).
DG-TR-7-59	Brandner, F.W., <u>Proposal for MERCURY-REDSTONE Automatic In-flight Abort Sensing System</u> , 5 June 1959 (Technical Scientific Staff, G&C Lab).
LOD Brochure	<u>FREEDOM 7, The First United States Manned Space Flight</u> , Undated MR-3, (LOD - BROCHURE).
MSFC DOD - PR	<u>Progress Report Launch Operations Directorate</u> , 13 January 1961 - 12 February 1961, 23 February 1961 (C) (LOD).
MSFC MTP-AERO-61-9	Leonard, E. L. <u>Revised Range Safety Data for the MERCURY-REDSTONE Project</u> , 17 February 1961 (C) (AERO).
MSFC TPR-M-60-12	Leonard, N. T., <u>MERCURY-REDSTONE Monthly Status Report</u> , December 1960 (C) (MPO)
MSFC STR-M-60-1	<u>MERCURY-REDSTONE Monthly Status Report</u> , January 1961 (MPO).
MSFC STR-M-61-4	<u>MERCURY-REDSTONE Monthly Status Report</u> , February 1961 (C) (S&MD).
MSFC STR-M-61-6	<u>MERCURY-REDSTONE Monthly Status Report</u> , March 1961 (C) (S&MD).
MSFC MTP-LOD-62-5	Bertram, E. P., Dutton, R. E., <u>Final Report MERCURY-REDSTONE Project Launch Operations</u> , 28 May 1962 (LOD).

MSFC MTP-M-QUAL-61-3	Conaway, J.D., <u>MERCURY-REDSTONE System Reliability Test Report, Rate Switches</u> , 13 April 1961 (IUO) (QUAL).
MSFC MTP-M-QUAL-60-10	Coleman, R.H., <u>Reliability Test Report Altitude Error Sensor MERCURY-REDSTONE System</u> , 30 November 1960 (IUO).
MSFC MTP-M-QUAL-60-11	Coleman, R.H., <u>MERCURY-REDSTONE System Reliability Test Report for Control Voltage Failure Detector</u> , 30 November 1960 (IUO) (QUAL).
MSFC MTP-M-RP-61-6	Dalton, Charles, <u>Mission Reliability of Booster Flight for MERCURY-REDSTONE</u> , 24 February 1961 (IUO) (RPD).

FLIGHT REPORTS

MERCURY-REDSTONE Flight, MR-1

MSFC MNM-M-AERO-2-60	Lisle, Ben J., Teague, Roger, <u>Project MERCURY-REDSTONE: Final Standard Trajectory for MR-1</u> , 1 August 1960 (C) (NASA).
MSFC MM-M-SAR-2.1-60	Davis, C.H., <u>Final Alignment Report of Missile MR-1</u> , 1 August 1960 (MSFC).
MSFC TIS	Jones, Charles B., <u>Technical Information Summary Concerning MERCURY-REDSTONE Mission MR-1</u> , 15 October 1960 (C) (G and CD).
MSFC MTP-M-TEST-61-10	Earnest, Hugh S., <u>Static Firing of MERCURY-REDSTONE No. 1 Test Nos. 347, 348, and 349</u> , April 1961 (IUO), MR-1 (TEST).
MSFC MTP-M-S&M-P-61-1	Riguelmy, J.R., <u>MERCURY-REDSTONE MR-1 Flight Analysis of Propulsion Unit and Associated Systems</u> , 5 January 1961 (C) (S&MD).
MSFC MTP-LOD-DIR-60-49.1	<u>Index and Test Results Part I of the Firing Test Report MERCURY-REDSTONE Vehicle MR-1</u> , 27 December 1960 (C) (LOD).
MSFC MTP-LOD-ED-60-49.2b	Hinds, Noble F., <u>Instrumentation Operation Analysis Part IIb of the Firing Test Report MERCURY-REDSTONE MR-1</u> , Undated (LOD)

MSFC MTP-LOD-MP-60-49.3 Martin, Thomas E., Firing Site Weight Report Part III of the Firing Test Report MERCURY-REDSTONE MR-1, 6 January 1961 (C) (LOD).

MSFC MM-M-SAR-2.3-60 Guidance and Control System Checkout MR-1, 3 August 1960 (MSFC).

MSFC MM-M-SAR-2.5-60 Covington, C.H., Pincham, A.G., Measuring System Analysis MR-1, 4 August 1960 (MSFC).

MSFC MM-M-SAR-2.6-60 Fisher, A.E., Pickard, M.F., Final Mechanical Analysis of MR-1 Thrust Unit, 5 August 1960 (MSFC).

MSFC MTP-LOD-EF-TR-49.2a-60 Gwinn, Ralph T., Consolidated Instrumentation Plan Part Iia of the Firing Test Report MERCURY-REDSTONE MR-1, 19 November 1961 (S) (LOD).

MSFC M-LOD-G-TR-49.4-60 Master Operational Schedule Part IV of the Firing Test Report MERCURY-REDSTONE Spacecraft MR-1, 15 November 1960 (OUD) (LOD).

MSFC MM-M-SAR-2-60 Final Acceptance Test Report MR-1, 12 September 1960 (SAR).

MSFC MM-M-SAR-2.4-60 Bryan, F.G., Test Conductor's Report MR-1, 1 August 1960 (SAR).

MSFC MTP-M-QUAL-61-7 Post-Firing Electrical Analysis MR-1 Thrust Unit, 28 February 1961 (IUO) (QUAL).

MERCURY-REDSTONE Flight MR-1A

MSFC TPR-M-61-1 Clarke, W.G., Preliminary Evaluation of MERCURY-REDSTONE Launch MR-1A, 13 January 1961 (C) (AERO).

MSFC STR-M-61-3 Ledford, Harold, Actual Trajectory of MERCURY-REDSTONE Flight Test MR-1A, 1 March 1961 (C) (AERO).

MSFC MTP-AERO-61-10 Smith, J.W., Atmospheric Environment for MERCURY REDSTONE-1A Vehicle Flight, 24 February 1961 (IUO) (AERO).

MSFC MTP-M-S&M-P-61-5 Riquelmy, J.R., King, M.W., McDonald, N.G., MERCURY-REDSTONE MR-1A Flight Evaluation of Propulsion Unit and Associated Systems, 24 February 1961 (C) (S&MD).

MSFC MTP-LOD-DIR-61-61.1	<u>Index and Test Results Part I of the Firing Test Report MERCURY-REDSTONE Vehicle MR-1A, 16 January 1961 (C) (LOD).</u>
MSFC MTP-M-QD-60-8	<u>Final Acceptance Test Report MR-3, 15 December 1960 (IUO) (QUA).</u>
MSFC MTP-M-QD-60-8.1	Davis, C.H., <u>Final Alignment Report MR-3, 1 December 1960 (IUO) (QUAL).</u>
MSFC MTP-LOD-ED-60-61.2b	Hinds, Noble F., <u>Instrumentation Operation Analysis Part IIb of the Firing Test Report MERCURY-REDSTONE MR-1A, 2 February 1961 (C) (LOD).</u>
MSFC MTP-LOD-MP-60-61.3	Martin, Thomas E., Heezen, Kenneth F., <u>Firing Site Weight Report Part III of the Firing Test Report MERCURY-REDSTONE MR-1A, 2 February 1961 (C) (LOD).</u>
MSFC MTP-LOD-EF-60-61.2a	Gwinn, Ralph T., <u>Consolidated Instrumentation Plan Part IIa of the Firing Test Report MERCURY-REDSTONE MR-1A, 16 December 1960 (S) (LOD).</u>
<u>MERCURY-REDSTONE Flight, MR-2</u>	
MSFC TPR-M-60-1	Jones, Charles B., <u>Technical Information Summary Concerning MERCURY-REDSTONE Mission MR-2, 20 January 1961 (C) (G&CD).</u>
MSFC MTP-M-SAR-60-3.1	Davis, C.H., <u>Final Alignment Report MR-2, 10 October 1960 (SA&RD).</u>
MSFC STR-M-61-2	Clarke, W.G., <u>Preliminary Evaluation of MERCURY-REDSTONE Launch MR-2, 25 February 1961 (C) (AERO).</u>
MSFC MTP-AERO-61-30	Ledford, Harold, <u>Actual Trajectory of MERCURY-REDSTONE Flight Test MR-2, 4 April 1961 (C) (AERO).</u>
MSFC STR-M-61-7	Smith, J.W., <u>Atmospheric Environment for the Flight of MERCURY-REDSTONE 2, 25 March 1961 (AERO).</u>

MSFC MTP-M-COMP-61-2	Fallon, Robert A., Smith, Martha E., <u>DOVAP Flight Test Data Missile MR-2,</u> 1 March 1961 (C) (COMP).
MSFC MTP-M-S&M-P-61-10	Riquelmy, James R., King, Merle W., <u>MERCURY-REDSTONE MR-2 Flight</u> <u>Evaluation of Propulsion Unit and Asso-</u> <u>ciated Systems,</u> 2 June 1961 (C) (S&MD).
MSFC MTP-LOD-OIR-61-4.1	<u>Index and Test Results Part I of the Fir-</u> <u>ing Test Report MERCURY-REDSTONE</u> <u>Vehicle MR-2,</u> 20 February 1961 (C) (LOD).
MSFC MTP-LOD-EF-61-4.2a	Gwinn, Ralph T., <u>Consolidated Instru-</u> <u>mentation Plan Part Iia of the Firing Test</u> <u>Report MERCURY-REDSTONE MR-2,</u> 9 February 1961 (S) (LOD).
MSFC MTP-LOD-ED-61-4.2b	Hinds, Noble F., <u>Instrumentation Oper-</u> <u>ation Analysis Part Iib of the Firing Test</u> <u>Report MERCURY-REDSTONE MR-2,</u> 7 April 1961 (C) (LOD).
MSFC MTP-LOD-ED-61-4.3	Martin, Thomas E., <u>Firing Site Weight</u> <u>Report Part III of the Firing Test Report</u> <u>MERCURY-REDSTONE MR-2,</u> Undated (C) (LOD).

MERCURY-REDSTONE Booster Development Flight, MR-BD

MSFC MTP-M-COMP-61-6	Fallon, Robert A., Smith, Martha E., <u>DOVAP Flight Test Data MERCURY-</u> <u>REDSTONE BD,</u> 8 May 1961 (C) (COMP).
MSFC MTP-M-S&M-P-61-7	Riquelmy, J.R., King, M.W., McDonald, N.G., <u>MERCURY-REDSTONE</u> <u>MR-BD Flight Evaluation of Propulsion</u> <u>Unit and Associated Systems,</u> 3 August 1961 (C) (S&MD).
MSFC MTP-LOD-OIR-61-11.1	<u>Index and Test Results Part I of the Fir-</u> <u>ing Test Report MERCURY-REDSTONE</u> <u>Vehicle MR-BD,</u> 7 April 1961 (C) (LOD).
MSFC MTP-LOD-ED-61-11.2b	Hinds, Noble F., <u>Instrumentation Oper-</u> <u>ations Analysis Part Iib of the Firing Test</u> <u>Report MERCURY-REDSTONE MR-BD,</u> 14 April 1961 (C) (LOD).
MSFC MTP-LOD-MP-61-11.3	Heezen, Kenneth F., <u>Firing Site Weight</u> <u>Report Part III of the Firing Test Report</u> <u>MERCURY-REDSTONE MR-BD,</u> 17 April 1961 (C) (LOD).

MSFC MTP-LOD-EF-61-11.2a	Gwinn, Ralph T., <u>Consolidated Instrumentation Plan Part IIa of the Firing Test Report MERCURY-REDSTONE MR-BD</u> , 23 March 1961 (C) (LOD).
MSFC MTP-AERO-61-36	Clarke, W.G., <u>Preliminary Evaluation of MERCURY-REDSTONE Launch MR-BD</u> , 19 April 1961 (C) (AERO).
MSFC MTP-AERO-61-43	Ledford, Harold, <u>Actual Trajectory of MERCURY-REDSTONE Flight Test MR-BD</u> , 24 May 1961 (C) (AERO).
MSFC MTP-AERO-61-51	Smith, J.W., <u>Atmospheric Environment for MERCURY-REDSTONE BD Vehicle Flight</u> , 1 May 1961 (IUO) (AERO).
MSFC MTP-M-QUAL-61-4	<u>Final Acceptance Test Report Thrust Unit MR-5</u> , 21 March 1961 (IUO) (QUAL).
MSFC MTP-M-QUAL-61-4.1	Davis, C.H., <u>Final Alignment Report MR-5</u> , 24 February 1961 (QUAL).
MSFC MTP-M-QUAL-61-4.2	Lackey, M., <u>Electrical Systems Analysis MR-5</u> , 24 January 1961 (IUO) (QUAL).
MSFC MTP-M-QUAL-61-4.3	Bruce, R.B., <u>Test Conductors Report MR-5</u> , 23 January 1961 (IUO) (QUAL).
MSFC MTP-M-QUAL-61-4.4	Smith, A.G., <u>Radio Frequency Systems Test Report MR-5</u> , 26 January 1961 (IUO) (QUAL).
MSFC MTP-M-QUAL-61-4.5	<u>Guidance and Control System Ckeekout MR-5</u> , 31 January 1961 (IUO) (QUAL).
MSFC MTP-M-QUAL-61-4.6	<u>Measuring Systems Analysis MR-5</u> , 30 January 1961 (IUO) (QUAL).
MSFC MTP-M-QUAL-61-4.7	Sarture, A.C., <u>Final Mechanical Assembly Analysis Thrust Unit MR-5</u> , 13 March 1961 (IUO) (QUAL).
MSFC MTP-M-QUAL-61-4.8	Kulas, F., <u>Final Pressure and Functional Analysis, Thrust Unit MR-5</u> , 9 March 1961 (IUO) (QUAL).

MERCURY-REDSTONE Flight, MR-3

MSFC MPR-M-61-5	Martin, James J., Jr., <u>Description of MERCURY-REDSTONE Launch Vehicle for Flight No. MR-3</u> , 21 July 1961 (S&MD).
-----------------	---

MSFC MTP-M-TEST-61-6	<u>Earnest, H.S., Static Firing of MERCURY-REDSTONE No. 7 Test No. 346, 7 March 1961 (MR-BD) (TEST).</u>
MSFC MTP-M-COMP-61-7	<u>Fallon, Robert A., Smith, Martha E., DOVAP Flight Test Data MERCURY-REDSTONE 3, 26 July 1961 (C) (COMP).</u>
MSFC MTP-M-QUAL-61-10	<u>Final Acceptance Test Report Thrust Unit, MR-7, 7 April 1961 (IUO) (QUAL).</u>
MSFC MTP-M-QUAL-61-10.1	<u>Manning, F. T., Final Alignment Report Thrust Unit, MR-7, 3 April 1961 (IUO) (QUAL).</u>
MSFC MTP-M-QUAL-61-10.2	<u>Electrical Systems Analysis Thrust Unit, MR-7, 29 March 1961 (IUO) (QUAL).</u>
MSFC MTP-M-QUAL-61-10.3	<u>Lackey, M., Test Conductor's Report Thrust Unit, MR-7, 23 March 1961 (IUO) (QUAL).</u>
MSFC MTP-M-QUAL-61-10.4	<u>Norton, C. M., Radio Frequency Systems Test Report Thrust Unit MR-7, 20 March 1961 (IUO) (QUAL).</u>
MSFC MTP-M-QUAL-61-10.5	<u>Guidance and Control System Checkout Thrust Unit, MR-7, 24 March 1961 (IUO) (QUAL).</u>
MSFC MTP-M-QUAL-61-10.6	<u>Instrumentation Analysis Thrust Unit MR-7, 31 March 1961 (IUO) (QUAL).</u>
MSFC MTP-M-QUAL-61-10.7	<u>Sartore, A. C., Final Mechanical Assembly Analysis Thrust Unit MR-7, 6 April 1961 (IUO) (QUAL).</u>
MSFC MTP-M-QUAL-61-10.8	<u>Kulas, F., Final Pressure and Functional Analysis, Thrust Unit MR-7, 30 March 1961 (IUO) (QUAL).</u>
MSFC MTP-M-S&M-P-61-16	<u>Riquelmy, James R., King, Merle W., MERCURY-REDSTONE MR-3 Flight Evaluation of Propulsion Unit and Associated Systems, 3 August 1961 (C) (S&MD).</u>
MSFC MTP-LOD-ED-61-17.2b	<u>Hinds, Noble F., Instrumentation Operation Analysis Part IIb of the Firing Test Report MERCURY-REDSTONE MR-3, 29 June 1961 (C) (LOD).</u>
MSFC MTP-LOD-MP-61-17.3	<u>Heezen, Kenneth F., Firing Site Weight Report Part II of the Firing Test Report MERCURY-REDSTONE MR-3, 22 May 1961 (C) (LOD).</u>

MSFC MTP-M-QD-60-8.2	<u>Electrical Systems Analysis MR-3</u> , 7 December 1960 (IUO) (QUAL).
MSFC MTP-M-QD-60-8.3	Bruce, R. B., <u>Test Conductor's Report MR-3</u> , 6 December 1960 (IUO) (QUAL).
MSFC MTP-M-QD-60-8.4	Smith, A. G., <u>Radio Frequency Systems Test Report MR-3</u> , 1 December 1960 (IUO) (QUAL).
MSFC MTP-M-QD-60-8.5	<u>Guidance and Control System Checkout MR-3</u> , 2 December 1960 (IUO) (QUAL).
MSFC MTP-M-QD-60-8.6	<u>Measuring System Analysis MR-3</u> , 2 December 1960 (IUO) (QUAL).
MSFC MTP-M-QD-60-8.8	Kulas, F., <u>Final Mechanical Pressure and Functional Analysis of Missile MR-3</u> , 5 December 1960 (IUO) (QUAL).
MSFC MTP-LOD-EF-61-16	Gwinn, Ralph T., <u>Provisional Instrumentation Plan Number 1 MERCURY-REDSTONE MR-3</u> , 7 April 1961 (C) (LOD).
MSFC MTP-LOD-EF-61-17.2	Gwinn, Ralph T., Dean, Kenneth J., <u>Consolidated Instrumentation Plan Part IIa of the Firing Test Report MERCURY-REDSTONE MR-3</u> , 28 April 1961 (C) (LOD).
MSFC STR-M-61-8	Jones, Charles B., <u>Technical Information Summary Concerning MERCURY-REDSTONE MR-3</u> , 20 April 1961 (G&CD).
MSFC MTP-AERO-61-49 (Super)	Clarke, W. G., <u>Preliminary Evaluation of MERCURY-REDSTONE Launch MR-3</u> , 8 June 1961 (C) (AERO).
MSFC MTP-AERO-61-53	Ledford, Harold, <u>Actual Trajectory of MERCURY-REDSTONE Flight Test MR-3</u> , 14 June 1961 (C) (AERO).
MSFC MTP-AERO-61-59	Smith, J. W., <u>Atmospheric Environment for the MERCURY-REDSTONE 3 Vehicle Flight</u> , 20 July 1961 (IUO) (AERO).
MSFC MTP-LOD-OIR-61-17.1	<u>Index and Test Results Part I of the Firing Test Report MERCURY-REDSTONE Vehicle MR-3</u> , 23 May 1961 (C) (LOD).
<u>MERCURY-REDSTONE Flight, MR-4</u>	
MSFC MPR-M-61-1	<u>MERCURY-REDSTONE Monthly Status Report</u> , 15 May 1961 (C) (QUAL).

MSFC MPR-M-61-2	<u>MERCURY-REDSTONE Monthly Status Report, 12 June 1961, MR-4 (QUAL).</u>
MSFC MPR-M-61-3	<u>MERCURY-REDSTONE Monthly Status Report, 5 July 1961, MR-4 (QUAL).</u>
MSFC MPR-M-61-4	<u>MERCURY-REDSTONE Monthly Status Report, July 1961 (C), MR-4 (QUAL).</u>
MSFC MTP-M-QUAL-61-20	<u>Final Acceptance Test Report, Thrust Unit MR-8, 21 June 1961 (IUO) (QUAL).</u>
MSFC MTP-M-QUAL-61-20.1	Davis, C.H., <u>Final Alignment Report Thrust Unit, MR-8, 1 June 1961 (QUAL).</u>
MSFC MTP-M-QUAL-61-20.2	<u>Electrical System Analysis Thrust Unit, MR-8, 19 June 1961 (IUO) (QUAL).</u>
MSFC MTP-M-QUAL-61-20.3	Nash, E.C., <u>Test Conductors Report Thrust Unit, MR-8, 17 June 1961 (IUO) (QUAL).</u>
MSFC MTP-M-QUAL-61-20.4	<u>Radio Frequency Systems Test Report Thrust Unit, MR-8, 17 June 1961 (IUO) (QUAL).</u>
MSFC MTP-M-QUAL-61-20.6	Gibson, J.H., <u>Instrumentation Analysis Thrust Unit MR-8, 17 June 1961 (IUO) (QUAL).</u>
MSFC MTP-LOD-EF-61-20	Gwinn, Ralph T., Dean, Kenneth J., <u>Provisional Instrumentation Plan Number 1 MERCURY-REDSTONE MR-4, 3 June 1961 (LOD).</u>
MSFC MTP-LOD-G-61-23, IIa	Gwinn, Ralph T., Dean, Kenneth J., <u>Consolidated Instrumentation Plan Part IIa of the Firing Test Report MERCURY-REDSTONE (Booster No. 6, Capsule No. 11) 14 July 1961 (C) (LOD).</u>
MSFC MTP-LOD-MP-61-23.3	Heezen, Kenneth F., Hill, Lawrence F., <u>Firing Site Weight Report Part III of the Firing Test Report MERCURY-REDSTONE MR-4, 2 August 1961 (C) (LOD).</u>
MSFC MTP-M-G&C-61-29	Jones, Charles E., <u>Technical Information Summary Concerning MERCURY-REDSTONE Mission MR-4, 29 June 1961 (IUO) (G&CD).</u>
MSFC MTP-AERO-61-19	Speer, F.A., <u>Preliminary Evaluation of MERCURY-REDSTONE Launch MR-4, 8 December 1960 (C) (AERO).</u>

MSFC MTP-AERO-61-69	Clarke, W.G., <u>Preliminary Evaluation of MERCURY-REDSTONE Launch MR-4, 22 August 1961 (C) (AERO).</u>
MSFC MTP-AERO-61-74	Smith, J.W., <u>Atmospheric Environment for the Flight of MERCURY-REDSTONE MR-4, 28 September 1961 (IUO) (AERO).</u>
MSFC MTP-AERO-61-76	Ledford, Harold, <u>Actual Trajectory of MERCURY-REDSTONE Flight Test MR-4, 22 September 1961 (C) (AERO).</u>
MSFC MTP-P&VE-P-61-20	Riquelmy, J.R., King, N.W., Montgomery, J.L., <u>MERCURY-REDSTONE MR-4 Flight and Evaluation of Propulsion Unit and Associated Systems, 9 November 1961 (C) (P&VE).</u>
MSFC MTP-LOD-OIR-61-23.1	<u>Index and Test Results Part I of the Firing Test Report MERCURY-REDSTONE Vehicle MR-4, 15 August 1961 (C) (LOD).</u>
MSFC MTP-LOD-ED-61-23.2b	Hinds, Noble F., <u>Instrumentation Operations Analysis Part IIb at the Firing Test Report MERCURY-REDSTONE MR-4, 24 August 1961 (C) (LOD).</u>
MSFC MTP-LOD-MP-61-23.3	Heezen, Kenneth F., Hill, Lawrence F., <u>Firing Site Weight Report Part III of the Firing Test Report MERCURY-REDSTONE MR-4, 2 August 1961 (C) (LOD).</u>