

11

27a JPL - Technical Memorandum No. 33-145 *mk*

3 THE USE OF A CONVENTIONAL WIND
TUNNEL AS A MULTIGAS FACILITY *6*

Howard Koester
Gilbert Herrera
Donald Hanks *7*

Robert E. Covey
Robert E. Covey, Chief
Aerodynamic Facilities Section

1 JET PROPULSION LABORATORY
CALIFORNIA INSTITUTE OF TECHNOLOGY
PASADENA, CALIFORNIA *3*
9 April 8, 1963 *10 cv*

18 PAGES

Copyright © 1963
Jet Propulsion Laboratory
California Institute of Technology

Prepared Under ⁵Contract No. NAS 7-100 *2901*
National Aeronautics & Space Administration

CONTENTS

I. Introduction	1
II. The Problem	2
III. Test Techniques	2
IV. Special Equipment and Instrumentation	4
V. Results	5
VI. Future Work	9
Table 1. Comparison of liquefaction effects for CO ₂ -air and air alone	7
Appendix. Sample operation of the SWT	10

FIGURES

1. CO ₂ supply system for the HWT.	11
2. CO ₂ entering the return pipe downstream of the SWT diffuser.	12
3. Successful CO ₂ supply system for the SWT	13
4. System for determining percent CO ₂ by volume	14
5. Liquefaction effects of CO ₂ -air mixture on pitot-pressure distribution	15

THE USE OF A CONVENTIONAL WIND TUNNEL
AS A MULTIGAS FACILITY

ABSTRACT

This report presents the results of utilizing the Jet Propulsion Laboratory 21-in. hypersonic and 20-in. supersonic wind tunnels as continuous flow multigas facilities. Carbon dioxide (CO_2) was used as the contaminating gas. Concentrations up to 70% by volume of CO_2 were obtained at Mach numbers 2.6 and 6.0. The techniques, special equipment, instrumentation used, and results are discussed. This study is of particular interest since aerodynamic testing in atmospheres approximating those of Venus and Mars appears to be feasible in facilities originally designed to use air as the working fluid.

I. INTRODUCTION

For some time increasing interest has been shown in testing spacecraft models in gases somewhat different from air. Consequently, it was desirable to determine if the two continuous-flow wind tunnels at the Jet Propulsion Laboratory (JPL) could be made to perform as multigas facilities.

A test program was initiated in the JPL 21-in. hypersonic wind tunnel (HWT) in which carbon dioxide (CO_2) was used as the contaminating gas. CO_2 was selected because of its stability under the running conditions possible in

the HWT, its nontoxicity, availability, and relative inexpensiveness. Even more important is the fact that the atmospheres of both Venus and Mars, as compared with Earth, are rich in CO_2 . If a CO_2 -rich environment could be established in the JPL wind tunnels, the utility of these tunnels could be extended, thus aiding the planetary exploration program.

This paper discusses the results of the initial program to establish the feasibility of operating the HWT as a multigas facility and the results of a subsequent study in the 20-in. supersonic wind tunnel (SWT).

II. THE PROBLEM

There were two separate problem areas. The first consisted of: (1) the introduction of a known quantity of CO_2 into the tunnel circuit, (2) the accurate measurement of the CO_2 concentration in the supply section of the tunnel, and (3) the procedure for maintaining, within acceptable limits, a constant concentration of CO_2 in the test section. The second part of the problem was to obtain uniform flow when a CO_2 -rich atmosphere was the working fluid.

III. TEST TECHNIQUES

Three methods of introducing CO_2 into the tunnel circuit were tried. During the first test period in the HWT an attempt was made to introduce liquid CO_2 from a standard liquid- CO_2 container into the downstream end of the diffuser as shown in Fig. 1. The CO_2 tended to freeze when expanded through the control valves thus plugging the supply line and resulting in intermittent flow of CO_2 to the diffuser.

For the second test period in the HWT it was decided to convert liquid CO₂ to the gaseous state before introduction into the diffuser. Control was greatly simplified and was very adequate, but the necessity to generate steam for the liquid-to-gas converters was a decided inconvenience.

Analysis of the control problem which prevailed during the first HWT test suggested that the liquid CO₂ should be metered by an orifice placed at the terminus of the CO₂ supply line inside the diffuser. Then the dry ice which is created during the expansion would sublime immediately in the diffuser air as shown in Fig. 2. Figure 3 shows the arrangement of the CO₂ supply system which was developed and used successfully for the subsequent test in the SWT. In this system, the coarse metering is done by the orifices, while the valves are used only for flow shut-off or for small variations in flow to the orifices. Thus the pressure drop across the valves (when there is flow through them) is so small that no freezing occurs. A manifold of orifices as shown in Fig. 3 was chosen so that a wide variety of CO₂-air mixtures could be generated for several test-section Mach numbers. The Veejet nozzles which were obtained from System Spraying Company produced a fan-shaped spray in a plane perpendicular to the air flow in the diffuser. This resulted in rapid evaporation and sublimation of the CO₂ as it entered the diffuser.

Throughout the program techniques were selected which took advantage of the conditions which normally exist in various parts of the tunnel circuit. For instance, CO₂ was introduced into the diffuser where the pressure is well below one atmosphere rather than in the supply pipe where the pressure

is usually substantially above one atmosphere. As a result the CO₂ had to travel through the entire tunnel circuit before reaching the test section and therefore thorough mixing of the air and CO₂ was accomplished. In addition, it was convenient to take the sample of gas to be analyzed for CO₂ content from the tunnel supply section.

In both tunnels the quality of the flow in the test section was determined by utilizing a semi-vertical traverse mechanism with pitot probes.

IV. SPECIAL EQUIPMENT AND INSTRUMENTATION

The method of introduction of gaseous CO₂ into the HWT is shown in Fig. 1. A large tank trailer with a maximum storage capacity of 19,000 lb of liquid CO₂ under 250-300 psig pressure was used to supply liquid CO₂ to two liquid-to-gas converters. These converters were simple heat exchangers utilizing steam for the heat source. The gaseous CO₂ was then routed through either the flow meter for establishing low to moderate concentrations or through the 2-in. line for higher concentrations.

In the HWT the temperature of the gaseous CO₂ was monitored throughout the test by a 5-millivolt Brown readout for the two thermocouples shown in Fig. 1. The temperature of the gas was kept at about 140°F at the measurement points to inhibit the occurrence of a change of state at areas of expansion in the piping. In contrast, the SWT system required no special equipment in addition to the Veejet nozzles. Liquid Carbonic, a Division of General Dynamics, supplied the CO₂, the steam generator, and the liquid-to-gas converters.

The concentration of CO₂ by volume was continually determined by using a Beckman Model 15a infrared analyzer.¹ The output of the analyzer was read from a 5-millivolt Brown readout. A schematic drawing of the complete system is shown in Fig. 4. A simple heat exchanger was used to keep the temperature of the gas sample between 70 and 100°F.

The analyzer was equipped with a reference cell which was calibrated for a selected range of CO₂ by volume in air. The reference cell used was calibrated for 0 to 15% CO₂ by volume. Cells for other ranges could be made but were not readily available.

V. RESULTS

The technique used to introduce gaseous CO₂ into the SWT circuit was most satisfactory and will also be used for future work in the HWT. A sample operation is described in the Appendix. Different levels of CO₂ concentration were established at nozzle contour settings corresponding to Mach numbers (M) for air of 1.8, 2.6, 5, 6.5, and 7.3. At present the maximum Mach number at which testing can be done is about 2.6 in the SWT and 7.3 in the HWT. The limiting factor is the maximum temperature available (160°F for the SWT from the heat of compression and 1350°F from the HWT heater). Air-CO₂ mixtures require much higher temperatures than air alone in order to avoid condensation effects. Experimental comparisons are shown in Table 1. In Fig. 5 a plot is presented which shows the effect on the pitot-pressure

¹ More details of the gas analyzer can be found in Beckman Instruction Manual for the L/B Infrared Analyzer Model 15a.

distribution of the onset of liquefaction for the $M = 2.6$ and 5 nozzles. Similar trends occurred at all Mach numbers investigated ($1.8 < M < 7.3$). The pressure traces were obtained from semi-vertical traverses.

It was noted that as the supply pressure was reduced for constant CO_2 -air mixtures, liquefaction occurred at a significantly lower temperature (a trend which is consistent with liquefaction effects for "pure" air). But when liquefaction effects at various concentrations of CO_2 at constant supply pressure were investigated; indications were that the amount of CO_2 present seemed to have only a minor effect on the temperature at which liquefaction effects appeared. The explanation of this apparent anomaly is not obvious and will require more analytic and experimental work.

The maximum concentration of CO_2 which was run was 70% by volume. In the HWT this was achieved in the $M = 6$ nozzle for a supply pressure of 900 cm Hg abs and a supply temperature of 1200°F . To maintain this concentration, it was necessary to continuously put 2 to 3 lb of CO_2 per second into the tunnel to make up for leakage of air into the below-atmosphere part of the circuit. In the SWT this was done in the $M = 2.6$ nozzle for a supply pressure of 120 cm Hg abs and a supply temperature of 160°F . It was necessary to continuously add 7-8 lb of CO_2 per second into the tunnel circuit in order to maintain the concentration. In both cases even higher concentrations of CO_2 can be conveniently achieved.

Table 1. Comparison of liquefaction effects for CO₂-air and air alone

Mach No. *	Total pressure cm Hg abs	Approximate CO ₂ concentration % by vol in air	Total temperature below which liquefaction effects appear, °F	
			For CO ₂ -air mixtures	For air alone
5.07	515	11.6	775	150
6.49	200	15.2	950	300
6.52	200	10.0	950	300
6.56	800	5.4	1200	420
6.56	800	10.5	1200	420
7.13	200	14.4	1200	380

*Mach number was calculated using standard air tables. No attempt was made to determine the "real" Mach number at this time.

It was learned that adequate CO₂ percentage readings could be obtained up to 30% by volume using the 15% cell after experimentally extrapolating its calibration curve. In addition, when operating with concentrations above 15%, samples of the gas mixture were collected periodically and carefully analyzed using chemistry laboratory techniques and equipment.

The degree of flow uniformity was checked by semi-vertical pitot-pressure traces. The HWT traverse has two pitot probes which straddle the tunnel centerline and are 6 in. apart. When not in use, the probes are retracted flush with the tunnel ceiling. The traverse crosses the tunnel centerline approximately 15 in. upstream of the center of model rotation and moves in a plane inclined 15 deg to the vertical. The SWT traverse, similar to the HWT instrument, incorporates only one pitot probe. The pitot pressure is plumbed to a 15-psia Statham pressure transducer which supplies a signal that is continuously plotted during a traverse by a Moseley x-y plotter. The x scale represents inches below the tunnel ceiling; the y scale represents pressure units (cm Hg abs).

The ability to accurately measure the concentration of CO₂ in the tunnel was demonstrated. At concentrations from 0 to 15%, the analyzer readout gave readings which were accurate to $\pm 0.1\%$ CO₂ by volume.² Accuracy decreased somewhat at higher concentrations, but significant test results could still be obtained.

²The instrument was previously calibrated to this accuracy by using known mixtures of CO₂ and air.

Attempts were also made to establish and hold a desired concentration. After gaining a little experience, concentrations could be quickly established to within 0.5% and held to $\pm 0.2\%$ of that desired. CO_2 was easily purged from the tunnel circuit by evacuating the tunnel to a low pressure after bypassing the tunnel flow at the end of a run. This purging was accomplished in from 2 to 3 min.

When liquefaction was avoided, the nozzle contours normally used for "pure" air were adequate for air- CO_2 concentrations up to 70% by volume. The uniformity of the flow as indicated by the vertical pitot-pressure traces was essentially as good as for the "pure" air case, the condition for which the nozzle shapes had been optimized.

VI. FUTURE WORK

The effect of CO_2 -air mixtures on aerodynamic coefficients will be studied in the SWT and HWT. Some of this work has recently been performed and will be discussed in a subsequent report.

Better control of the introduction of CO_2 into the tunnel circuit is certainly possible. A servo control can be developed which would automatically hold the concentration of CO_2 relatively constant.

APPENDIX. Sample Operation in the SWT

For the $M = 1.8$ nozzle contour and a supply pressure of 80 cm Hg abs and a supply temperature of 115°F, the mass flow through the tunnel is 85 lb/sec. To test in a mixture of 20% CO₂ and 80% air by volume the following must be done after starting the tunnel and reaching the above supply conditions (refer to Fig. 3).

1. Fully open the 3/8-in. ball valve which raises the CO₂ content of the tunnel "air" to 20% by volume in about 4 min; CO₂ mass flow is 3 lb/sec.
2. Close the ball valve and maintain the 20% CO₂ concentration with the 1/4-in. globe valves and Veejet nozzles; CO₂ mass flow is 1 lb/sec.

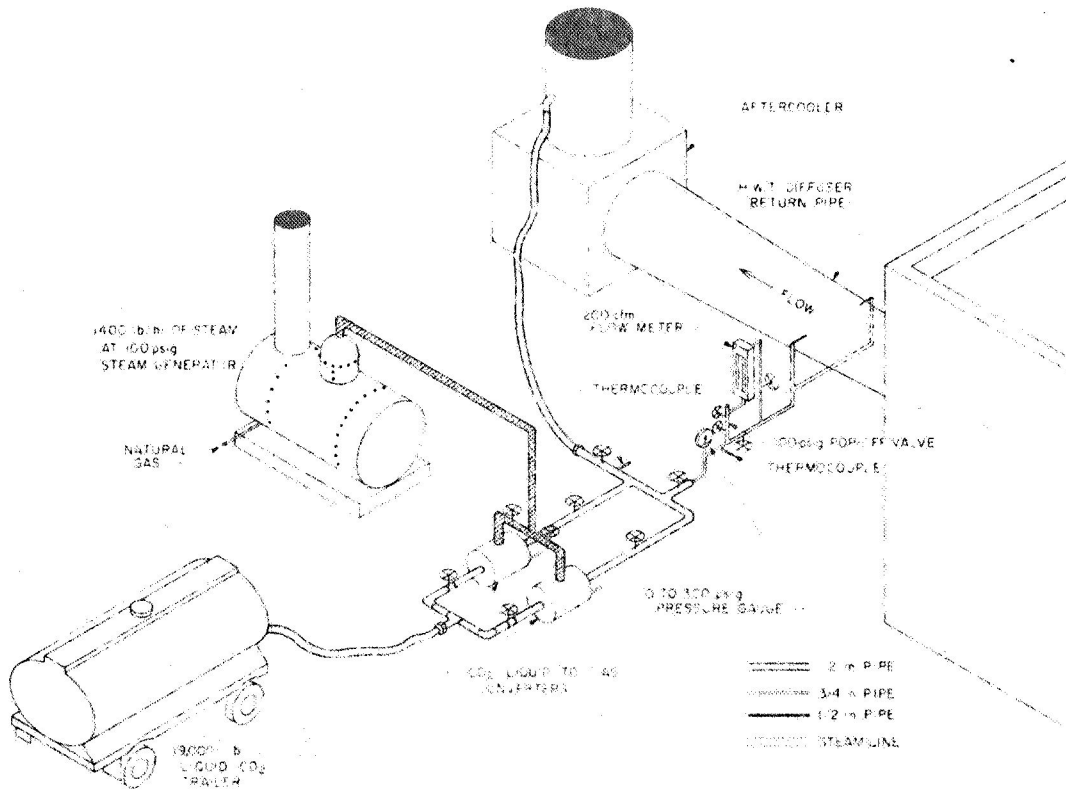
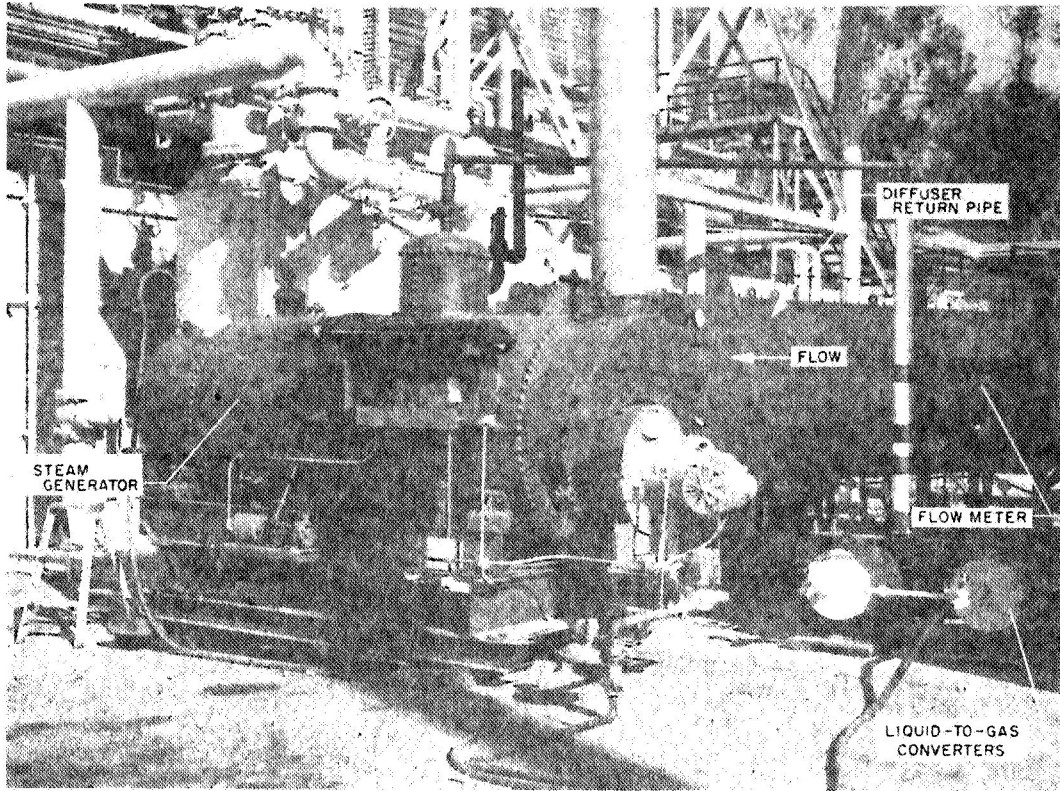

Fig. 1. CO₂ supply system for the HWT

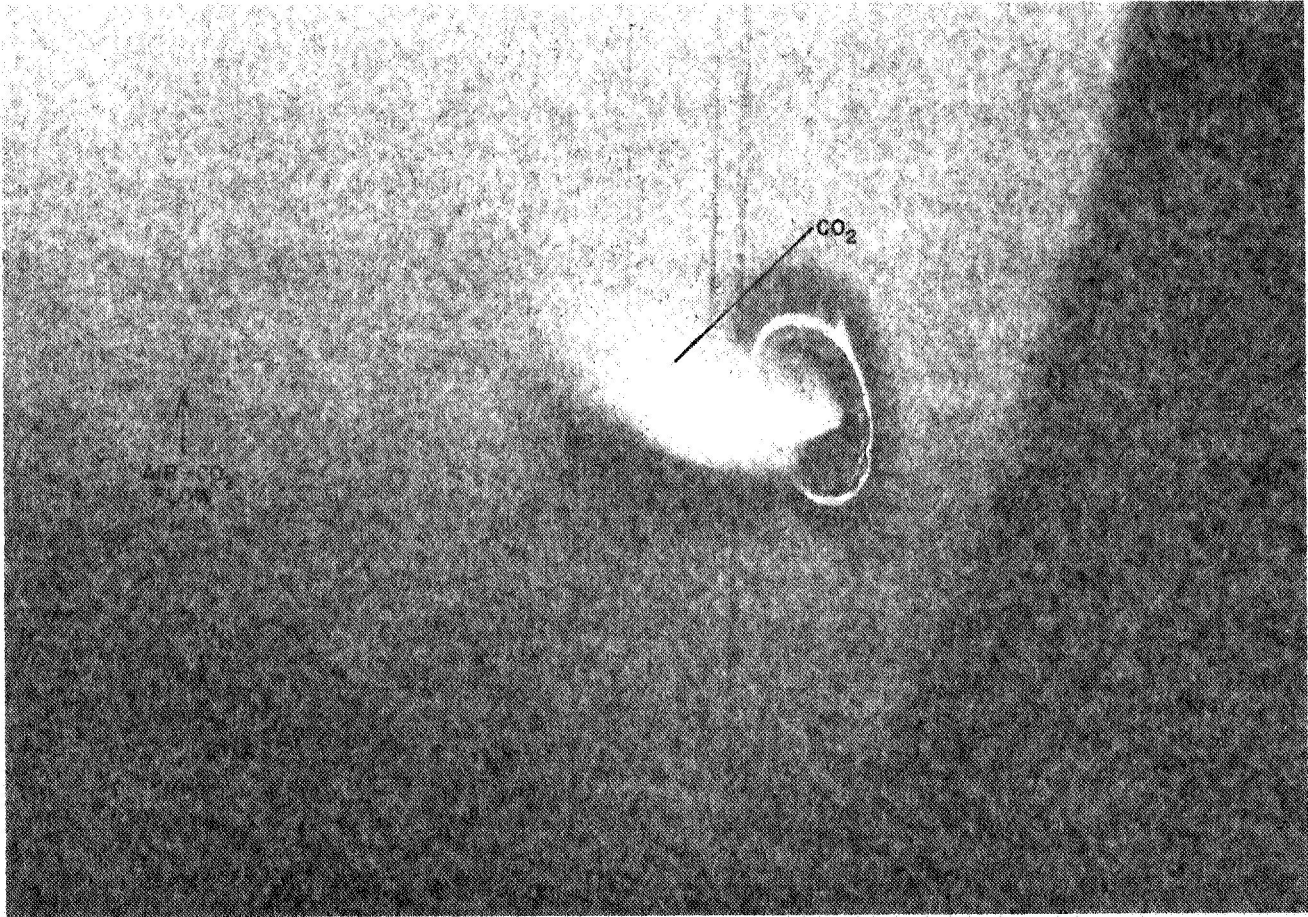

Fig. 2. CO₂ entering the return pipe downstream of the SWT diffuser

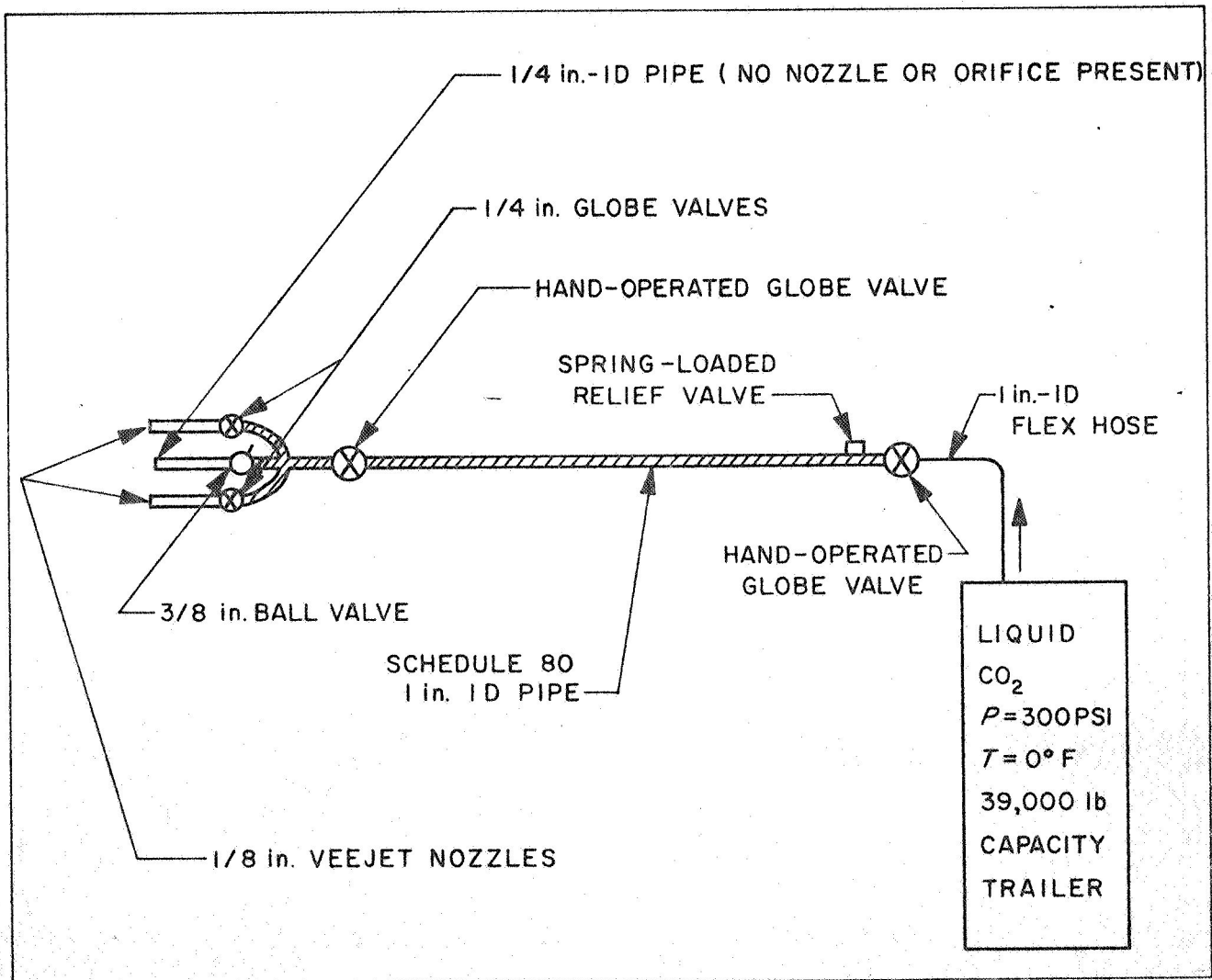
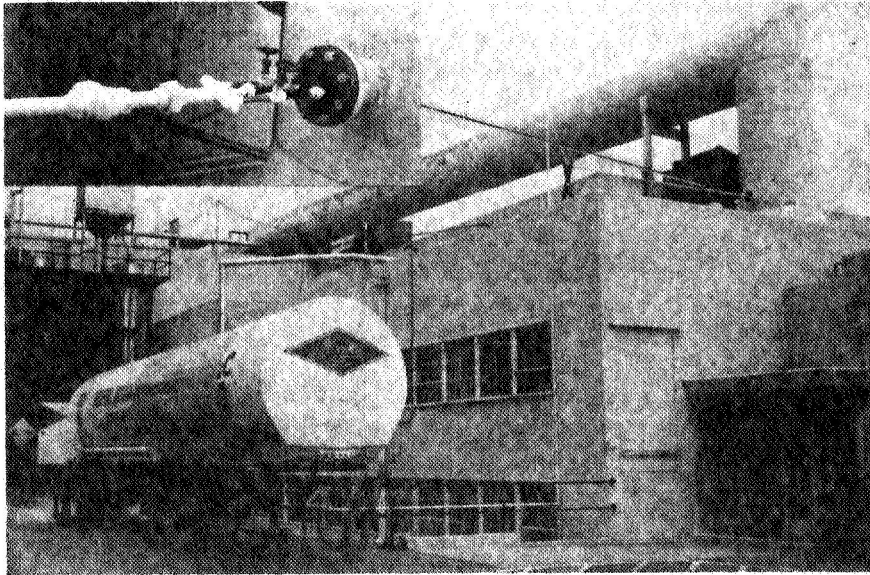
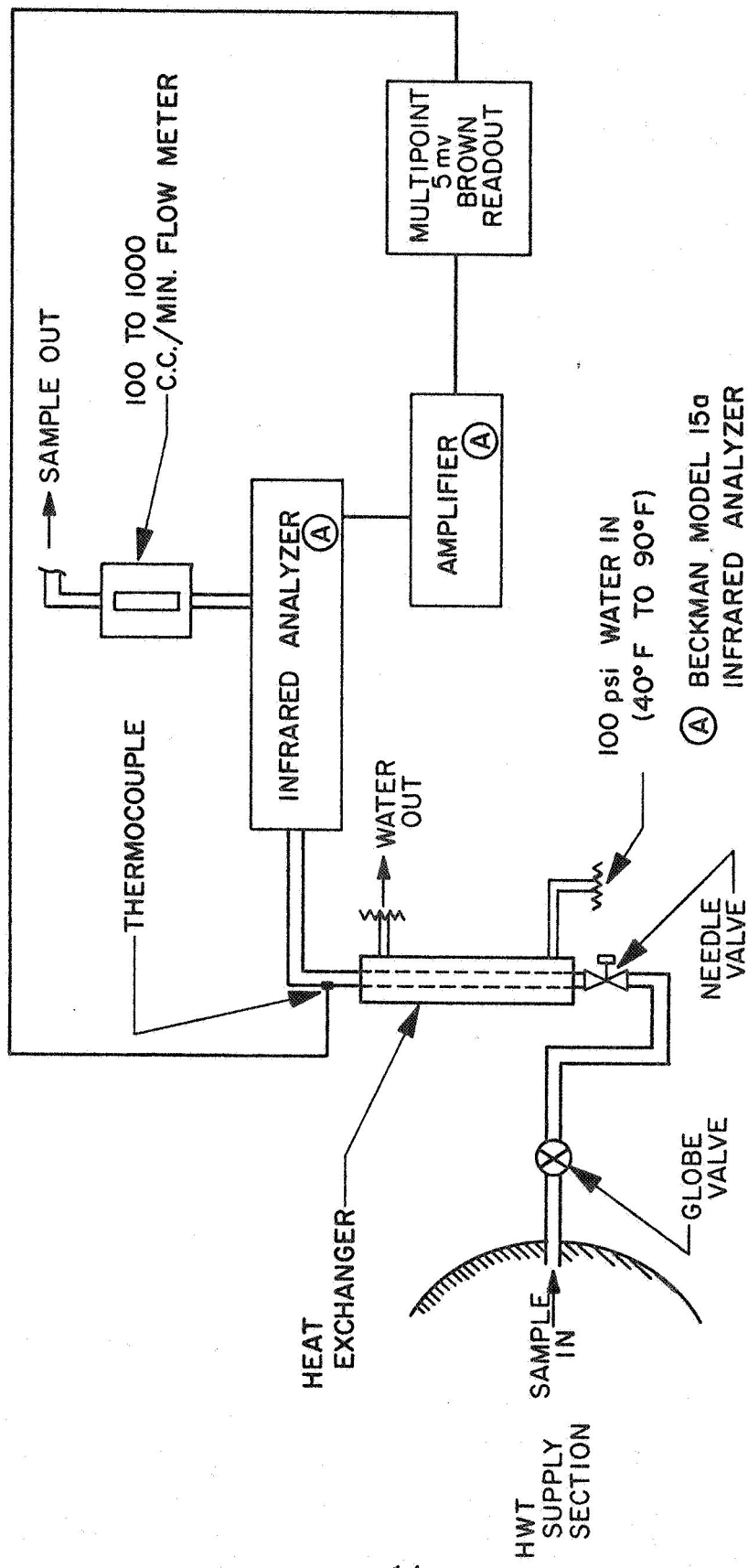

Fig. 3. Successful CO₂ supply system for the SWT



(A) BECKMAN MODEL 15a
INFRARED ANALYZER

Fig. 4. System for determining percent CO₂ by volume

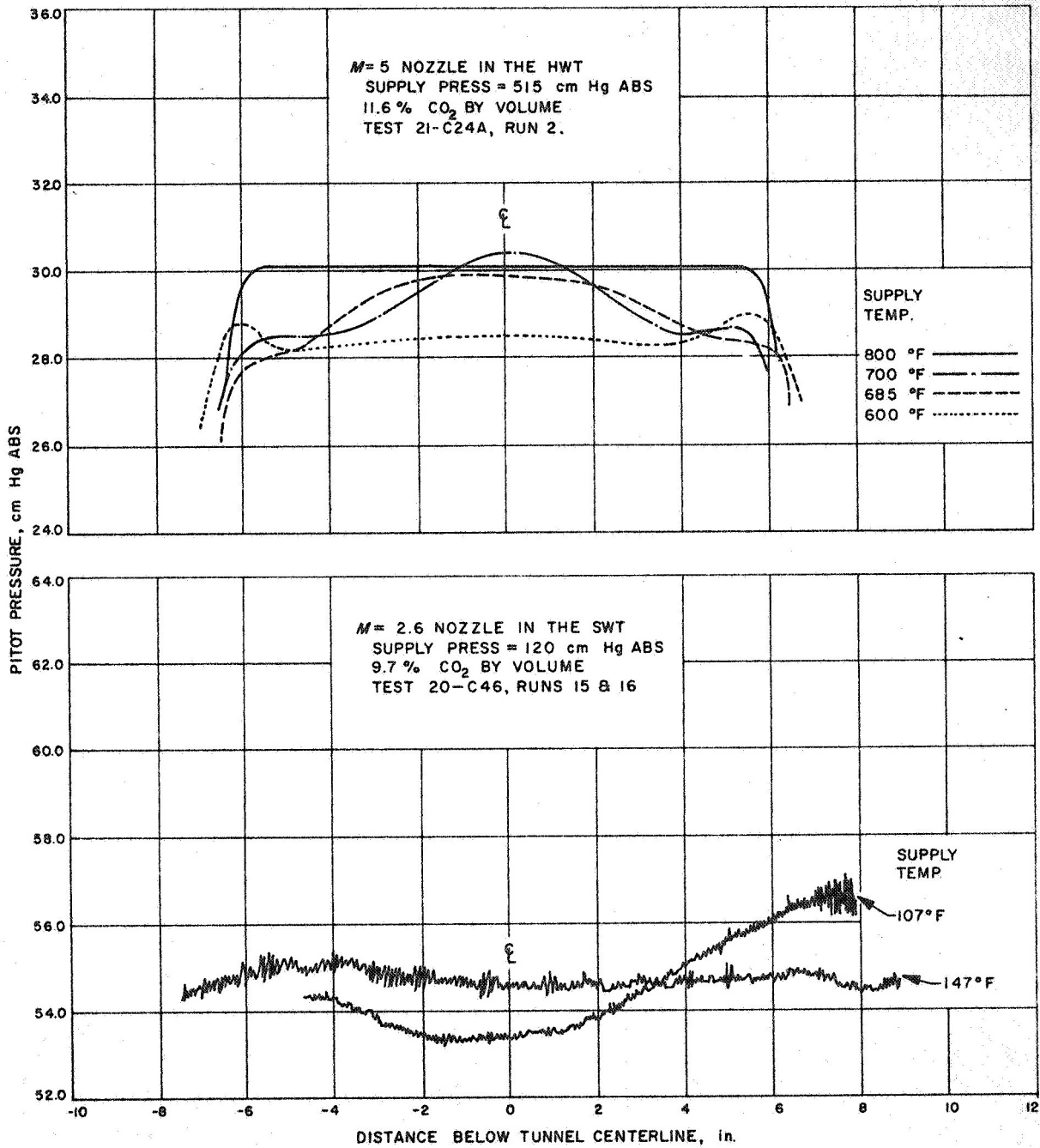

Fig. 5. Liquefaction effects of CO₂-air mixture on pitot-pressure distribution