

Technical

NASA Contractor Report No. 66523

Final Report

F-C1853

Report

A STUDY OF PACKAGING AND SHIPPING PROCEDURES FOR  
SMALL ELECTROEXPLOSIVE DEVICES

by

C. T. Davey

W. J. Dunning

Distribution of this report is provided in the interest of information exchange. Responsibility for the contents resides in the author or organization that prepared it.

1 May 1966 - 1 August 1967

Prepared for

LANGLEY RESEARCH CENTER

National Aeronautics and Space Administration

NASA Contract NAS 1-6280



F-C1853

Final Report F-C1853  
"A Study of Packaging and Shipping  
Procedures for Small Electroexplosive  
Devices."

Dr. J. R. Feldmeier  
Director of Laboratories

Charles T. Davey, Warren J. Dunning  
The Franklin Institute Research Laboratories  
1 May 1966 through 1 August 1967  
For National Aeronautics and Space Administration  
This work was carried out in the Applied Physics  
Laboratory, E. E. Hannum, Laboratory Manager  
Technical direction of this work at  
Langley Research Center was provided  
by Mr. Richard Mulliken and by  
Mr. Earl VanLandingham, AMPD

#### ABSTRACT

The sensitivity, environment and response of electric initiators and their explosive components are discussed and analyzed. Responsiveness in the natural and packaged states to heat, electrical and mechanical stimuli are considered. Environment is defined in terms of best available information on storage temperatures; lightning, radio frequency and static electricity; and the mechanical stimuli that an EED can receive in normal shipment.

It is concluded that present ICC regulations consider safety of the carrier and the general public. These regulations do not provide for the electrical safety of the devices being shipped nor do they provide completely for protection of the reliability of the electric initiators.

It is recommended that shielding be provided for initiators in transit and in storage. Metal foils should be used at once and more suitable designs for shielding from low-frequencies should be developed for use in the future to enhance safety and reliability

## TABLE OF CONTENTS

	<u>Page</u>
ABSTRACT . . . . .	i
1. INTRODUCTION . . . . .	1
2. SENSITIVITY AND TOLERANCE LEVEL . . . . .	7
2.1 General Failure Modes in EEDs . . . . .	7
2.2 Temperature and Heat . . . . .	9
2.3 Electrical Effects . . . . .	12
2.3.1 General Sensitivity to Electrical Stimuli . . . . .	12
2.3.2 Static Electricity, Bulk Explosive Material . . . . .	12
2.3.3 Radio Frequencies . . . . .	19
2.4 Mechanical Sensitivity . . . . .	20
2.5 Summary of Section . . . . .	22
3. ENVIRONMENT OF ELECTROEXPLOSIVE DEVICES . . . . .	23
3.1 General . . . . .	23
3.2 Heat . . . . .	23
3.3 Electrical . . . . .	24
3.3.1 Lightning Storms . . . . .	24
3.3.2 Static Electricity . . . . .	30
3.3.3 Radio Frequencies . . . . .	34
3.4 Mechanical . . . . .	35
3.5 Summary of Section . . . . .	36
4. RESPONSE OF ELECTRIC INITIATORS . . . . .	37
4.1 General . . . . .	37
4.2 Heat . . . . .	37
4.3 Electrical . . . . .	38
4.3.1 Response to Lightning Stimuli . . . . .	39
4.3.2 Response to Static Discharges . . . . .	44
4.3.3 Response to Radio Frequency . . . . .	47

Contents (Cont.)

4.4	Mechanical Response . . . . .	50
4.5	Summary of Section . . . . .	63
5.	DISCUSSION OF PACKAGING PROBLEMS AND POSSIBLE SOLUTIONS .	64
5.1	Heat . . . . .	64
5.2	Electrical . . . . .	64
5.3	Mechanical . . . . .	67
5.4	Indicators for Monitoring Shipments . . . . .	68
6.	CONCLUSIONS AND RECOMMENDATIONS . . . . .	71
6.1	Conclusions . . . . .	71
6.2	Recommendations . . . . .	73
	BIBLIOGRAPHY . . . . .	74
	APPENDICES	
A.	Approximation of Induced Potentials in Remote Loops Due to Lightning Discharges. . . . .	A-1
B.	Summary of ICC Regulations Governing the Transportation and Packaging of Electroexplosive Devices. . . . .	B-1
C.	Recommended Procedures for Defining Initiator Sensitivity, Providing Adequate Package Protection and Assuring Safe Handling Environments. . . . .	C-1
D.	Experimental Evaluation of Anti-Static Plastic Materials. . . . .	D-1

## LIST OF FIGURES

<u>Fig. No.</u>		<u>Page</u>
1	Some of the Factors to be Considered in Initiator Packaging . . . . .	2
2	Firing Modes of Typical Electroexplosive Device . . . . .	8
3	Typical Sensitivity Curve of Electroexplosive Devices . . . . .	13
4	Energy Required for Given Functioning Probability of Common Explosive Materials . . . . .	15
5	Frequently Used Circuit to Determine the Minimum Energy for Explosive Ignition . . . . .	16
6	Response of Typical Explosive Material to Spark Gap With Series Resistance . . . . .	17
7	Static Electric Field Preceding a Thunderstorm . . . . .	26
8	Vertical Electric Field During Dynamic Portions of the Lightning Discharge . . . . .	27
9	Radial Electric Field in the Earth Surrounding a Lightning Strike . . . . .	29
10	Summary of the Effects of the Magnetic Field from a Lightning Discharge on Electric Initiators. . . . .	31
11	Shock Acceleration of Conventional Packages of Electro-Explosives at Impact . . . . .	52
12	Layout of EEDs for Propagation Tests in Packaging Dunnage . . . . .	53
13	Foam Aluminum Tested as Dunnage Material - Propagation Stop. . . . .	57
14	Effects of T24E1 Detonator on Polycarbonate Plastics: Various Configurations . . . . .	58
15	Effects of T24E1 Detonator on Polycarbonate Plastics: Various Configurations . . . . .	59

List of Figures (Cont.)

16	Effects of T24E1 Detonator on Polycarbonate Plastics: Various Configurations . . . . .	60
17	Effects of T24E1 Detonator on Polycarbonate Plastics: Various Configurations . . . . .	61
A-1	Assumed Shape of Magnetic Field from Lightning Discharge and Resultant EMF Induced in Loop . . . . .	A-4
A-2	Estimated Maximum Potentials Induced in Loops by Lightning Discharges . . . . .	A-5
D-1	Method of Measuring Surface Resistance of Conductive, Anti-Static Plastic Films . . . . .	D-4
D-2	Bulk Properties of Anti-Static Plastic Materials . . .	D-5

LIST OF TABLES

<u>Table No.</u>		<u>Page</u>
1	Ignition and Explosive Temperature of Commonly Used Explosive Materials . . . . .	10
2	Minimum Energies for Ignition of Various Explosive Materials . . . . .	16
3	Minimum Static Sensitivity of EEDs Tested at FIRL . . .	18
4	Impact and Friction Sensitivity of Explosives Commonly Used in Electric Initiators . . . . .	21
5	Maximum Values of Shock Received in Shipments by Various Carriers . . . . .	35
6	Explosive Propagation Tests in Dunnage Materials . . .	55
7	Description of Polycarbonate Materials Tested for Fragment and Blast Protection . . . . .	62
D-1	Discharge Measurements on Conductive Plastic Materials.	D-3

## 1. INTRODUCTION

According to Goff<sup>(1)\*</sup> the packaging business in the United States involves expenditures of around 21 billions of dollars each year and accounts for approximately 4% of the gross national product. This is slightly more than the contribution to the economy made by new housing in this country.

Packaging is established as a large business that encompasses many phases of bringing materials to the customer.

In this study our interest covers only a small portion of the whole scheme of packaging. We are concerned only in those aspects of packaging that apply to small electroexplosive devices (EEDs). By small we mean that the entire explosive contents is on the order of one gram or less.

The main interest in this study is in the safety and reliability of the EED during packaging, shipping, handling and installation in the vehicle for which it is intended to serve a function. These concerns are for the entire shipping and handling history of the device.

The aim of the program was to determine the sensitivity of EEDs generally to each of the driving forces that may set them off or otherwise affect them in the process of shipping and handling. Some of these are shown in Figure 1. Concurrently with determining sensitivitiy, we attempted to define the environments that could be experienced in normal shipping practices and in unpacking and handling. Subsequently the effects of these forces on the initiators were examined by comparing the stimulus that could be recieved with the sensitivity of the electric initiator in that particular mode.

Most of the work that was done involved literature reviews and analysis; however experimental work was performed on static electric effects

---

\* (1) See Bibliography at end of report.



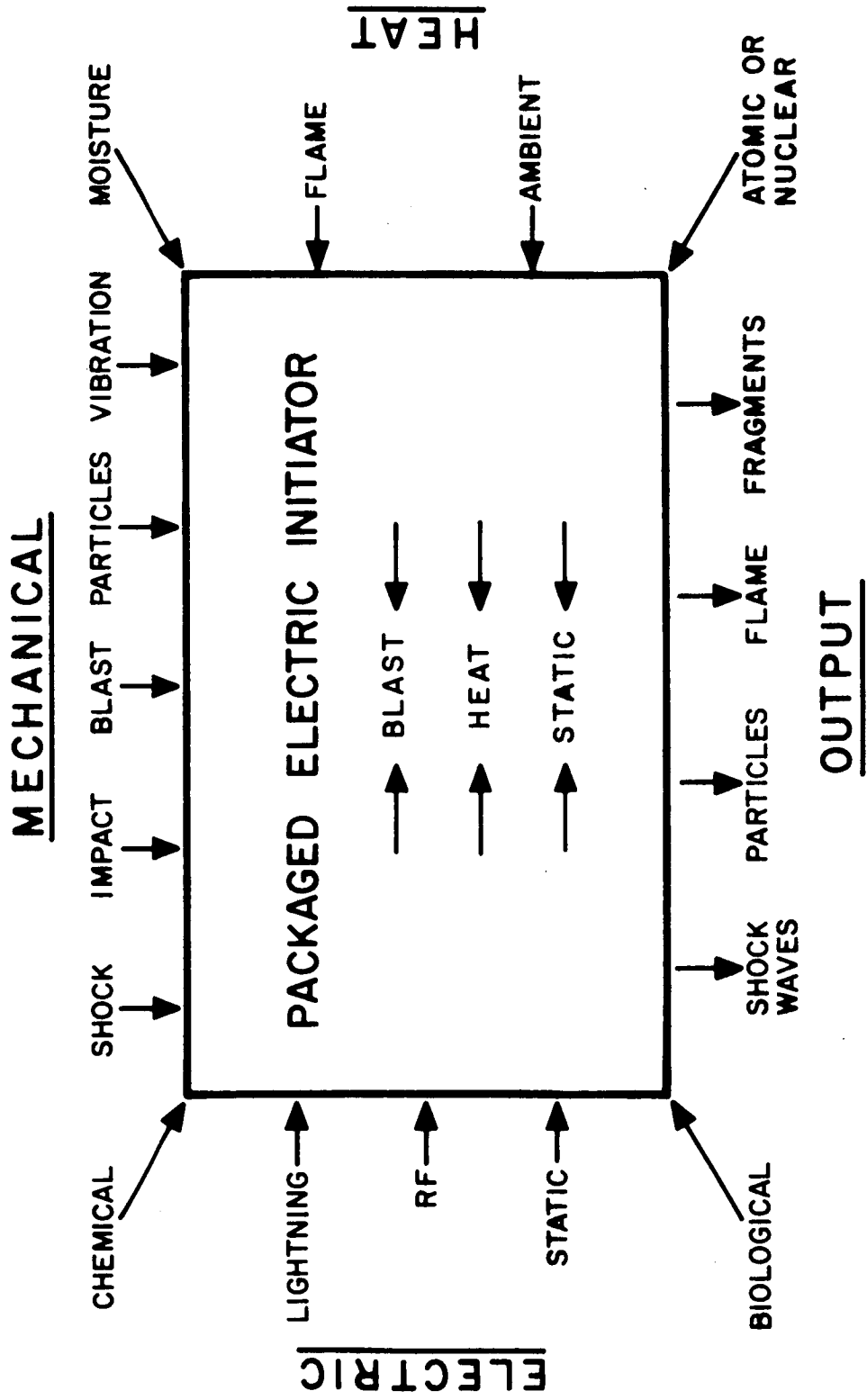

Fig. 1 - Some of the Factors to be Considered in Initiator Packaging

from anti-static plastics and on propagation of explosive output from one device to another in selected dunnage materials.

Reviews were made of current packaging practice for electroexplosive devices as carried out by explosive manufacturers and requirements of the ICC and other pertinent literature were reviewed in an effort to interpret the existing rules as they apply to the electroexplosive devices that we have chosen to call "small".

In a number of areas there appears to be little need for modification of current practice in packaging for shipment. Current practice by the explosive manufacturer is generally acceptable and fulfills the requirements of the ICC regulations for the shipment of EEDs. It is not believed that these rules are fully understood by all persons, or for that matter even by a majority of persons who practice shipping of EEDs. This is one reason for the summary that is contained in Appendix B.

There are areas that cannot generally be defined including the ability of each EED type to accommodate the energy of impact and both not fire and be serviceable. Still another area that needs consideration is the sensitivity of EEDs to electrical energy. Present manufacturers' specifications call out the "no-fire" current and the "all-fire" current. While these are certainly necessary, they are of little use in the assessment of pulses that might be applied to the EED by a lightning discharge or during the application of static discharges from human operators. Electrical information on EEDs in general is lacking, sketchy and presented in such a way that little can be learned of the safety aspects of the EED.

Most of the excitation levels that had to be considered were available. Transportation information is usually reliable from commercial sources and this is so because of the wide use of transportation facilities for the shipment of fragile materials. Similarly the criteria for packaging of most materials are reasonably well defined for the mechanical characteristics of devices where the limit of energy to break or harm the packaged device is known.

Vibration characteristics of the transportation media are also well known and the criteria for meeting vibration protection can be worked out readily. Again the characteristics of the initiator are not well known. Some of the limits of existing initiators are being examined for flight problems, but not for survival in packaging. The problem here seems to be minor, however, because the flight requirements are usually far more stringent than those of transportation.

Electrical hazards are little understood and greatly feared. It has been recently pointed out<sup>(2)</sup> that too much concern is given the RF problem and too little that of lightning and static; there is some basis for disagreement here. There appears to be little enough concern over all the electrical hazards involved in electroexplosives including those of RF, static electricity and lightning. All three of these potential hazards have been considered in this report with respect to the packaging problem. The broad treatment of the material is forced by the wide ranges of sensitivity that we can expect from the EEDs involved and from the very wide variations in frequency, power and pulse conditions from the electromagnetic sources and from charged objects and lightning discharges.

Heat and high temperatures have proven to be a problem with most available electroexplosive devices. Researchers in this area have experienced difficulty in attempts to sterilize spacecraft using heat<sup>(3)</sup>. A surprising number of available devices fail when exposed to temperatures around 145°C for periods up to 30 hours. Storage temperatures of this level are not common, and it is not too probable that they do or will exist in shipping or storage.

Chemical and humidity effects are not treated extensively in the literature. "Breathing" of the EED is probably one of the most serious problems that is encountered with humidity, and corrosion and fungus are nearly as troublesome. Chemical effects are usually those of contamination rather than direct chemical processes within the initiator as long as the materials contained in the EED are compatible with one another.

The conclusions that are reached within this report, as with any study of its kind, reveal more problem areas than solutions to these problems. While we must conclude from experience that present packaging procedures are reasonably safe, we cannot conclude that they will continue to be safe in the future with the increasing burden on the air waves of radar, communication devices and other emitters of electromagnetic energy.

While there is some concern over the effects of atomic radiation on explosive materials, it is generally conceded that the level of radiation and the total dose required to produce these effects is several orders of magnitude above the level that is lethal to human beings<sup>(4)</sup>. For this reason we have given little consideration to the problem of atomic or nuclear radiation as a part of normal package requirements.

An attempt has been made to spell out some specifications that we feel would protect the packaged EED to a greater extent that is presently required. Most of the specified conditions are now satisfied in part or totally by some manufactures. Others are called for in certain of the programs that are underway for specific vehicles or specific programs. Some are entirely new and reveal a need that has yet to be demonstrated by an accident. Intelligent and carefully planned handling of EEDs in protected environments will solve some of the problems that are involved in handling and operating with EEDs; but procedures alone cannot be considered a satisfactory solution to safety in all cases.

Examination of the ICC regulations for shipping and packaging<sup>(5)</sup> will point out that these regulations are intended to protect the carriers and the general public from harm as a result of an accident with hazardous materials. The intentions of these regulations are well taken and such requirements that have been set down must be met. These regulations do not go far enough for reliability or safety in today's problem areas.

If one is shipping a reefing cutter, for example, the package requirements are relaxed to the point where it could be free to move in the package. There are practically no requirements on dunnage and the component could conceivably be damaged by the stresses received in shipping. The same applies to a number of other devices that are not dangerous to the point that they create explosive output. Fortunately manufacturers are usually very aware of the quality of their product and make an effort to provide the best type of package to protect the product they sell until it is used.

This report contains three sections that deal with sensitivity environment and response. The first of these, Section 2, discusses what is known of the sensitivity of EEDs from controlled testing of these devices. The second involves the environment that a package of EEDs may encounter or that an EED may encounter in handling. The third treats the response of the EED and the package system to the environments defined.

Section 5 contains a discussion of the problems connected with packaging electroexplosive devices and indicates some possible solutions to these problems. Section 6 indicates conclusions that have been reached as a result of this study and recommends methods by which some of the problems characteristic of packaging EEDs may be further understood, reduced and minimized.

## 2. SENSITIVITY AND TOLERANCE LEVEL

### 2.1 General Failure Modes in EEDs

Wire bridge heating is not the most common mode of failure though it is the normal firing mode of the EED. Excitation in this mode can cause accidents or failure of the device to operate normally. If the applied energy is inadequate to fire the device and yet cause some heating of the explosive around the bridgewire it is possible to alter the sensitivity of the EED. This phenomenon is not fully understood, but concurrent studies are underway to better describe what happens<sup>(6)</sup>. Previous work establishes beyond reasonable doubt that prepulsing can severely decrease the sensitivity of EEDs and dudding has been experienced in some instances due to the application of pulses giving some indication of the degree of this effect. A more common problem is to have the device fire prematurely from heating of the bridgewire.

#### Pins-to-Case Sparking

Sparking or arcing from the bridgewire leads or from the bridgewire itself to the case of the initiator in such a way that the spark path is through some of the primary explosive most generally results in firing of the EED. The means by which the arc or spark is formed is usually from electrostatic energy or it may be from radio frequency energy of the pulsed type that has been observed to occur. Figure 2 shows the location of some of these phenomena on a cut-away view of a typical electro-explosive device. Some devices are built in such a way as to contain two sets of lead wires and two bridgewires for increased reliability through redundancy. This design introduces the possibility of a spark discharge from one bridgewire system to another in addition to the one from bridgewires to case.

Only in the past few years have users of EEDs and manufacturers become aware of the problem of excitation of an EED in other than the

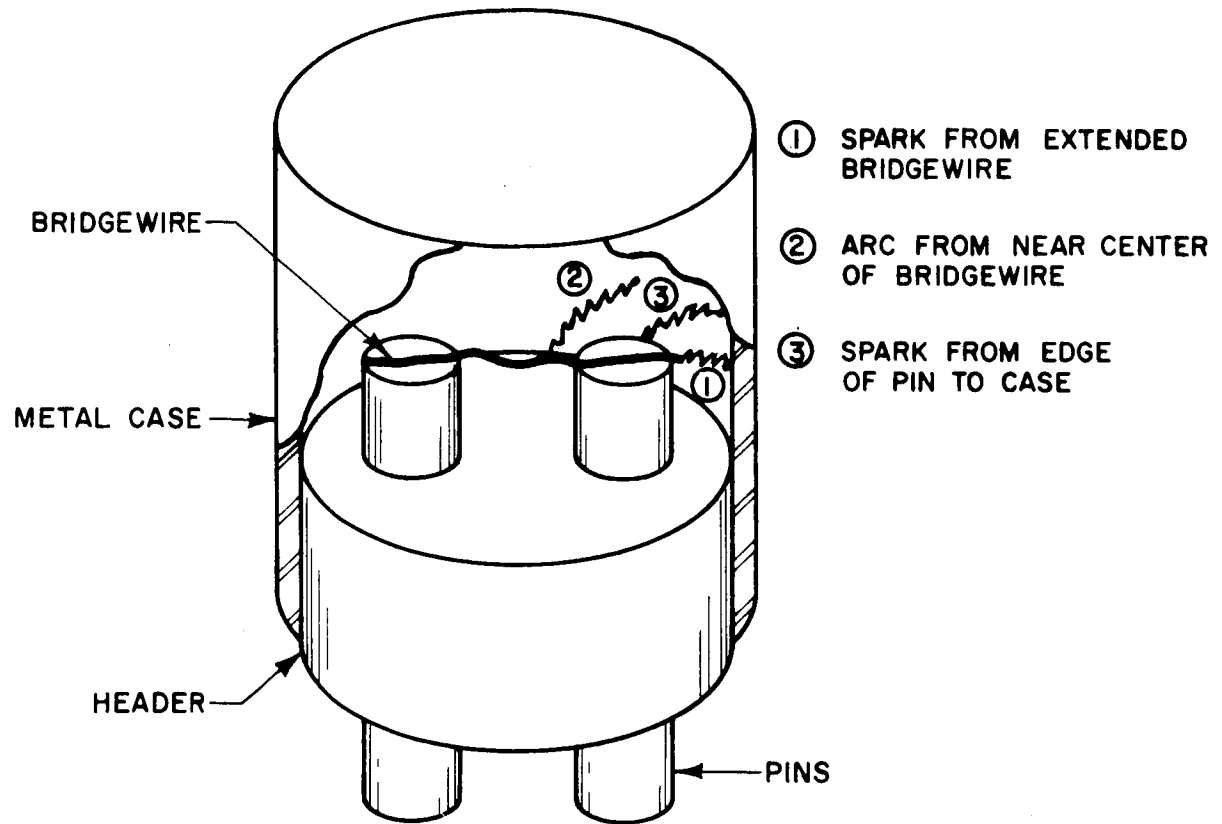

Fig. 2 - Firing Modes of Typical Electroexplosive Devices

bridgewire mode. Attempts are currently being made to design this problem out of the electroexplosive device<sup>(7)</sup>. Some success has been noted recently. It has been increasingly difficult to fire EEDs submitted for electrostatic testing. This does not mean that all devices currently in use are immune to static.

Referring once more to Figure 2, it will be noted that sparking or arcing is shown in three locations. One rather common characteristic that enhances arcing is an untrimmed portion of the bridgewire that extends over the end of the pin to which it is welded. Many of the devices that are most sensitive to static were found to contain this tab. Sharp corners of the pins themselves also encourage arcing. Arcing from the bridgewire to the case has been observed with RF excitation. This is probably due to the fact that the conductive path between pins and case presents a rather high impedance at many RF frequencies thus causing a relatively high voltage to appear across it. If the voltage (and power) is great enough sufficient arcing or current flow may occur to fire the initiator. It is suspected that in some instances heating of the dielectric materials in the EED due to RF will cause initiation of the device. This heat probably comes from dielectric losses in the materials near the explosive or from the explosive itself as the result of swaying of the dielectric dipoles or quadripoles which is accompanied by heat generation.

These are some of the problems that must be faced in providing protection for EEDs in the packaged state and in handling during unpackaging prior to installation of the device.

## 2.2 Temperature and Heat

By the nature of explosives when they are heated, they react and yield heat in decomposition. When the heat generated exceeds the heat losses, the reaction builds to the point where decomposition is sustained at a high rate. Studies have been made that give the ignition or explosion



temperature for certain explosive compounds. Some of these are shown in Table 1 and more are contained in the references cited.

Table 1

IGNITION AND EXPLOSION TEMPERATURES  
FOR COMMONLY USED EXPLOSIVE MATERIALS<sup>(8,9)</sup>

<u>Explosive</u>	<u>Explosion Temperature (°C)</u>
Tetracene	160
Nitrocellulose	170
DDNP	195
PETN	225
RDX	260
Lead Styphnate	282
Lead Azide	240

Popular belief is that heat is the basis of all explosive reactions regardless of the source of the heat. The systems that may apply this heat, the volume of explosive being heated, the time of exposure, the confinement and other factors complicate efforts to define a single value of explosion or ignition temperature for each material.

The problem of thermal ignition is not simply one of knowing the ignition temperatures of the constituent explosive materials, but a knowledge of the thermal characteristics of the explosives comprising the EED helps. When the materials are brought together to make up the complete EED, the thermal characteristics of the explosive materials are not the sole factor in determining sensitivity to heat. This has been pointed out in several studies that are recently completed or currently underway.

The General Electric Company<sup>(3)</sup> has recently studied the ability of electroexplosive devices to withstand dry sterilization temperatures. This work was done to assure that such devices could be sterilized by this

process and still function. Initiators were subjected to three cycles of temperature from ambient to 145°C and back to ambient, the maximum temperature being held for 36 hours in each of the three cycles. Of the thousands of commercially available devices surveyed in this study, a majority contained explosives not able to remain at 145°C without degradation. Of those remaining there was either insufficient information or the devices were not immediately available. About two dozen devices were finally tested in the sterilization process. The criterion for acceptability was that the device fire after the stated temperature cycle.

It is interesting to observe that the construction of the device was critical in determining the survivability. Difference between coefficients of thermal expansion, types of materials and adhesive, and means of explosive retention were found to be important. Failures were opened and found to have blackened and cracked ignition beads in 75% of the cases. The remaining failures were due to other mechanisms mentioned. The devices that did survive showed some of the construction characteristics that are desirable in EEDs. A welded, flush-mounted bridgewire with a compressed and well supported charge were found to be desirable. A doped or brushed-on (spotted) bridge mix was found particularly sensitive to the above ignition bead deterioration, mainly because of the volatile carriers used in the preparation of the slurry.

While in no case was an explosive reaction of the material reported in these tests, it is evident that a majority of currently used electroexplosive devices reaching a temperature of 150°C would be generally unreliable after this kind of exposure if the exposure was for a number of hours. We feel that shipment and storage temperatures should be limited to 100°C (212°F) or perhaps even 74°C (165°F) (the old military standard).

Efforts are currently underway to upgrade the heat resistance of EEDs and other explosive devices and explosive materials<sup>(10)</sup>. When some of these developments are put into practice, the requirements will be more relaxed for these heat-resistant EEDs; but in the interim we are faced with the transportation of existing devices. It is also expected that some of the conventional EEDs will be in use for some time in the future.

## 2.3 Electrical Effects

### 2.3.1 General Sensitivity to Electrical Stimuli

The problems associated with electric initiators could readily be translated to those of heat if all of the transfer mechanisms and boundary conditions could be defined. This is not usually possible, and design criteria are supplemented by experimental development programs.

Similarly, the sensitivity of electric initiators is usually characterized experimentally. Wire bridge devices in military use are usually evaluated in terms of current pulses ranging in time from a few microseconds through step functions lasting minutes. Current amplitude is usually varied at one specified pulse time. The shorter the pulse time, the more current that is required. These data are plotted in the form shown in Figure 3. Other variables may be plotted such as capacitance vs. voltage or voltage vs. time. Examination of a number of electric initiators<sup>(11)</sup> reveals that the most sensitive wire bridge detonator will not fire with a continuous current of 10 milliamperes applied. This is substantiated as a safe level by a number of other studies.

The 10-milliampere current is often used as the maximum measuring current for instruments that are designed for the measurement of bridge-wire resistance of electric initiators. It appears that this current is our only choice for the limiting value of the maximum no-fire current for wire bridge EEDs in general because of the wide range of sensitivities possible and found in actual usage.

### 2.3.2 Static Electricity, Bulk Explosive Materials

The effects of static electric charges on bulk explosive material was studied previously<sup>(9)</sup>. We feel that the results are still valid and that little has been added to the knowledge in this scientific area since the conclusion of the study. The remaining discussion is extracted in the main part from the referenced report.

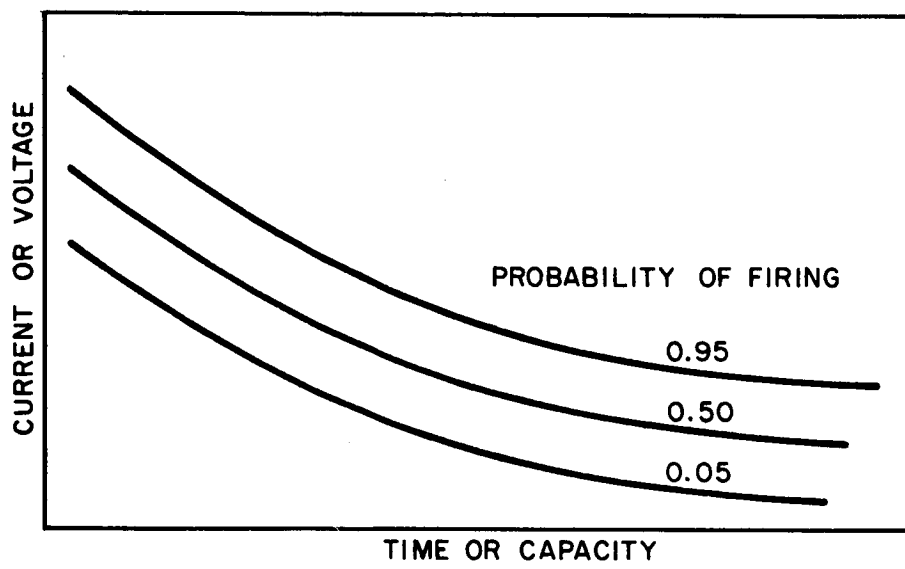

Fig. 3 - Typical Sensitivity Curve of Electroexplosive Devices

It is the consensus of researchers in this field that three factors are important with respect to the sensitivity of explosives to electrical discharges: (1) the minimum spark energy required for ignition, (2) the electrical properties of the materials, and (3) the environment of the material. In attempting to find the minimum energy required to fire explosives, it was soon discovered that the sensitivities determined by a number of experimenters varied greatly. This variation was partly due to the fact that there was great variation in the methods of determining sensitivities.

One of the best sources of information<sup>(12)</sup> included data on a number of common explosive materials, which are summarized in Figure 4. The data were obtained by discharging various capacitors charged to 5000 volts through the test material by means of a pointed electrode. The circuit used was similar to the one shown in Figure. 5. The test material was placed on a metal plate and the pointed electrode was lowered until discharge occurred.

Other studies have been made, with a resistance added in series with the capacitor and gap. A sample of the material under study was placed within the gap, which was usually a pointed electrode over a flat metal plate, as described earlier. Some of the values reported from various experimenters in this area are given in Table 2<sup>(13)</sup>. Particularly noteworthy in this table as well as in the text of the referenced report is the effect of adding series resistance to the firing circuit. For mercury fulminate, note that as the series resistance is added the energy required on the firing capacitor decreases rapidly, minimizes, and then increases. It has been observed that this is the rule rather than the exception for most explosive materials tested in this fashion, an exception being lead styphnate, which requires the least energy with no series resistance. A general rule has been developed relating series resistance, capacity and minimum energy. It states that the smaller the capacity, the greater the critical series resistance and the lower the minimum energy. The minimum energy requirements for

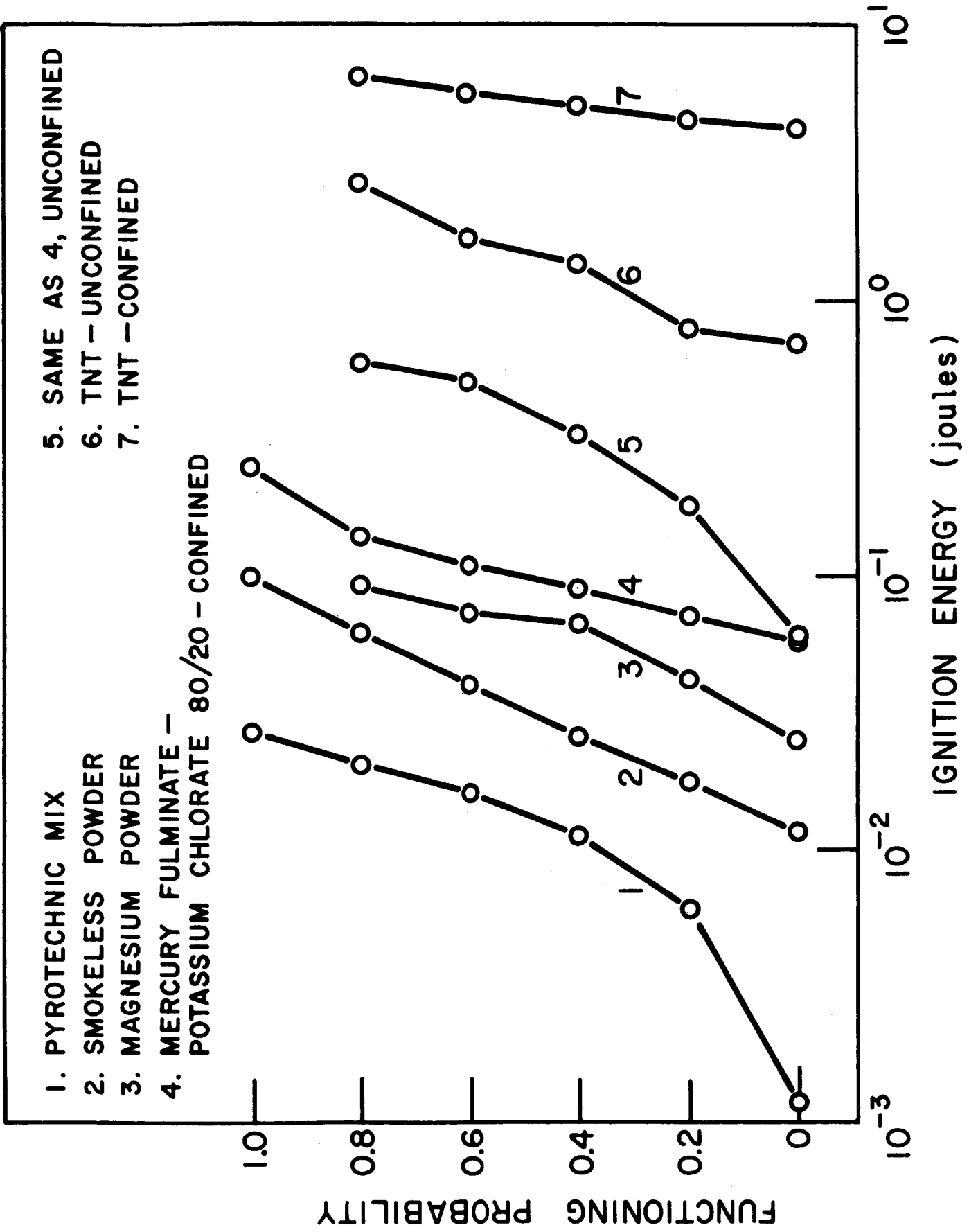

Fig. 4 - Energy Required for Given Functioning Probability of Common Explosive Materials

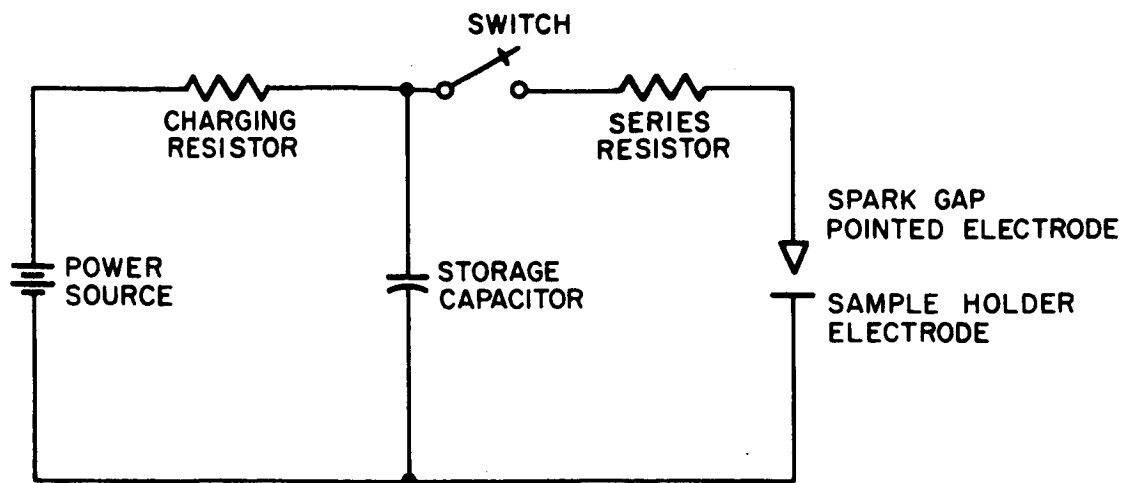

Fig. 5 - Frequently Used Circuit to Determine the Minimum Energy for Explosive Ignition

Table 2

MINIMUM ENERGIES FOR IGNITION OF VARIOUS EXPLOSIVE MATERIALS

<u>Material</u>	<u>Comments on Preparation or Testing</u>	<u>Minimum Energy on Firing Capacitor (Ergs)</u>
Copper Acetylde		20
Lead Styphnate	Basic Preparation (chemically)	30
	Normal; Energy measurement depends upon experimenter	140 to 9000
	Prepared in humidity less than 0.1%	3.8
	Prepared in humidity less than 1.8%	112.5
	Graphite added in amount of 1%	0.6
Lead Azide	Crystalline	400 to 18,000
	Dextrinated	70,000 to 280,000
Lead Dinitro-resorcinate		500
Mercury Fulminate	Unconfined	800,000
	Confined	200,000 to 250,000
	Series Resistance of 5,000 ohms	68,000
	Series Resistance of 25,000 to 750,000 ohms	37,500

ignition of an explosive material are changed by several orders of magnitude in some instances by the resistance in series with a circuit. Mr. A. R. Boyle in his thesis at the University of Birmingham, United Kingdom, (1943) showed a reduction in the ignition energy of mercury fulminate from 0.5 joule without any series resistance to 0.00375 joules with a series resistance of from 250,000 to 750,000 ohms.

This information may pertain to circuits containing electro-explosive devices as well as to explosively loaded components, and may be applicable in the pin-to-case testing of electroexplosive devices, or in the bridgewire-to-bridgewire testing of these devices for static safety. It has been previously pointed out that the human circuit is not the only means by which static energy can be delivered to explosive devices. This information indicates that it may be misleading to determine ignition energy under one condition of circuit constants for static safety and then to apply these across the board for all values of capacitance, resistance and voltage. This is brought out in Figure 6.

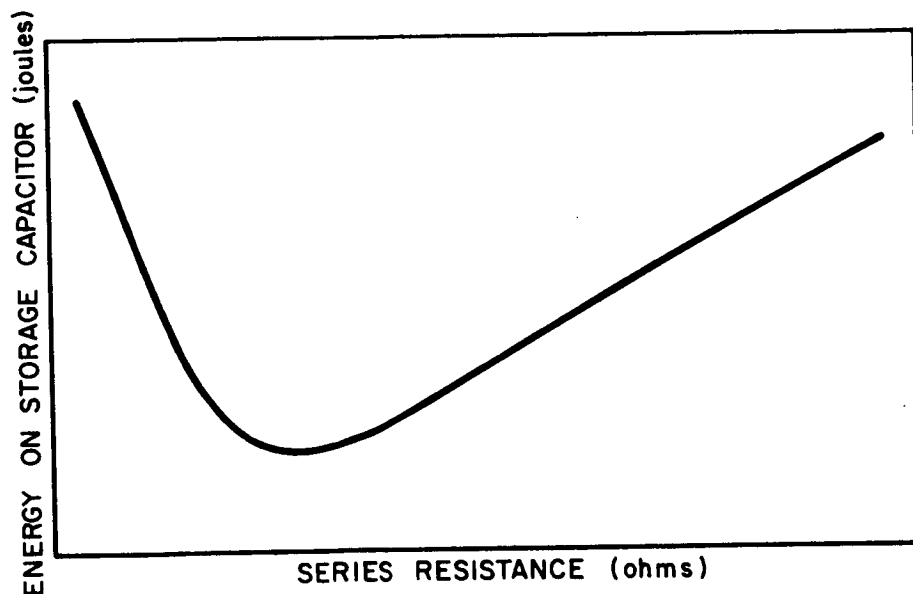

Fig. 6 - Response of Typical Explosive Material to Spark Gap with Series Resistance



In looking at the values of resistance for which energy requirements are relatively low, it appears that some are near the leakage resistance values of certain components. A resistance of 750,000 ohms differs not greatly from that of a contaminated insulator; and by the "rules" set down previously, this might be just the value of series resistance for firing from a small capacitor with minimum applied energy.

### Complete Initiators

As was mentioned earlier, any input that can cause heating of the explosive material directly, without the need to bring a transducer element such as a wire bridge to temperature can cause firing at much lower energy values than could be achieved with a transducer (wire bridge). While static types of sources have caused firing in the bridgewire mode, it is more likely that the EED will be activated in the pins-to-case mode. An examination was made of some of the tests conducted at FIRL in the past. The results of these tests are summarized in Table 3.

Table 3

#### MINIMUM STATIC SENSITIVITY OF EEDs TESTED AT FIRL

<u>Device No.</u>	<u>Capacity</u>	<u>Voltage</u>	<u>Contract Reference or Code</u>
SD60A0	500	5000 bridge-to-bridge	NAS-5-3878
SD38B0	500	5000 (P to C)	NAS-5-3878
SD38A0	500	No fires to 24KV (P to C)	NAS-5-3878
SD60A0	500	No fires to 24KV (P to C)	NAS-5-3878
SD11A2	500	3,500 (P to C)	NAS-5-3878
SD60D1	500	No fires to 25KV (P to C)	NAS-5-3878
FND-209	500	1 of 5 at 2KV, 1 of 5 at 12KV (P to C)	NAS-5-3878
S94*	500	No fires to 25KV (P to C)	NAS-5-3878

(P to C) indicate that the voltage is applied from pins-to-case.

\*Langley Research Center has reported some firings of this device under conditions stated here.

We are not at all certain, in light of existing information whether the findings of the studies on bulk explosives can be extended to include EEDs, for little has been done in evaluating the full effects of static discharges on EEDs.

All of the documented work to this date indicates studies on complete electric initiators have been slanted toward personnel borne charges. Little other work has been found to justify application of findings on bulk explosives to those of complete EEDs. The main question concerns the effects of circuit parameters, series resistance and capacitance, on the firing energy in the pins-to-case mode. From the results experienced by others<sup>(13)</sup>, it appears that there may be a critical series resistance for various EEDs.

### 2.3.3 Radio Frequencies

At least 43 devices have been fully evaluated for RF sensitivity at FIRL<sup>(14)</sup>. One of the most sensitive devices tested has a 5% probability of firing if 87 milliwatts is applied to the input leads (bridgewire). It is generally true that no device has been found to require less RF power than dc power for the same functioning probability when the power is applied CW (continuous wave) through the bridge circuit at frequencies below 1000 MHz. However, when the power is applied pins-to-case or bridge-to-bridge at higher frequencies the initiators may be considerably more sensitive to RF than to dc particularly when the RF is pulse modulated. The initiators may be more sensitive to pulsed RF in the bridgewire mode (than to dc) due to the thermal stacking effect if the pulse repetition is faster than the time required for the bridge system to cool (thermal time constant). Typical radar pulse repetition rates are 800-1000 pulses per second and typical EED thermal time constants are 1 to 10 milliseconds so thermal stacking is not an uncommon phenomenon.

In the pins-to-case and bridge-to-bridge modes the sensitivity to pulsed RF often appears to be primarily a voltage phenomenon, high voltages

being associated with high peak power in the short pulses. If the impedance pins-to-case or bridge-to-bridge is high at a particular frequency then high voltages will be impressed and arcing through the explosive mix is very likely to occur. This is similar to the static electricity phenomenon, and a trend indicating high correlation between static and RF-pulsed sensitivities has been observed.

RF problems are as much involved with lead configuration as with sensitivity of the EED itself. Past experience has shown that initiators are in themselves sensitive to most frequencies through the x-band and even beyond.

An important part of the RF problem rests in the "antenna" and its ability to remove RF energy from the surroundings and deposit the energy in the EED. This entire picture has been described previously<sup>(15)</sup> in terms of antenna aperture that is defined as the ratio of the power deposited in the load, (the EED), to the power density in the ambient field. This concept is a tool for evaluation of hazards.

#### 2.4 Mechanical Sensitivity

Individually there is little that has been done in connection with the sensitivity of electric initiators to impact. Certain military tests, e.g. MIL-STD 322 require the drop testing of electric initiators from a 40-foot height in a test fixture simulating the fuze body. Requirements are that the EED does not function and that no samples shall be unsafe for subsequent handling or disposition.

Electric detonators are used in artillery ammunition that experiences accelerations in the vicinity of 50,000 G. These devices are expected to function reliably after experiencing these accelerations.

It is generally agreed that initiation of explosives by impact is thermal in nature, the explosive being heated by compression of interstitial gas, intercrystalline friction and viscous flow.

Impact and friction tests have been made on a number of explosive materials by Picatinny Arsenal in a test apparatus that bears that name. The test consists of dropping a 2 kilogram weight on an explosive sample contained in a small steel die cup. A similar apparatus and test technique has been developed by the Bureau of Mines. The drop height is given as the sensitivity of a particular explosive and it represents the minimum height at which at least one of 10 trials results in an explosion.

The sensitivity of explosives to friction is determined by exposing a sample of the explosive to the action of a fiber or steel shoe attached to the end of a pendulum. A qualitative explanation is given of the results in the form of explosion (E), snaps (S), cracks(C), or unaffected (U) in decreasing order of reaction.

The results of these tests on some materials used in electric initiators is shown in Table 4.

Table 4

IMPACT AND FRICTION SENSITIVITY OF EXPLOSIVES  
COMMONLY USED IN ELECTRIC INITIATORS<sup>(8)</sup>

Explosive	Picatinny Arsenal Impact Test Drop Height (in.)	Picatinny Arsenal Friction Test Steel Shoe
Lead Azide	3	E
Lead Styphnate	8	E
Cyclonite (RDX)	8	E
PETN	6	C
Tetryl	8	C
Black Powder	16	S

Another form of mechanical energy to which explosives and electro-explosive devices are sensitive is the output from other explosives and explosive devices. This means that if one device in a package is accidentally set off, then the protection provided by the package should prevent continued

propagation of the reaction. High explosives are tested to find critical gap dimensions for barriers that are set between the explosive that provides the impetus (the donor) and the explosive that receives the impetus from the donor (the acceptor). These distances are difficult to compute because of the wide variety of physical constants of the explosive materials (that are usually granular) and because the gap is critically dependent upon the confinement of both acceptor and donor. Directional properties of the explosions, dependent on device design, also have a large influence.

Because of these factors, a limited number of tests were made on the ability of a high-output blasting cap to detonate a small electric detonator. Results are reported in Section 4.4.

## 2.5 Summary of Section

- (1) Predominant failure modes have been identified by cause: Pins-to-Case sparking, bridgewire-to-case sparking, heating of bridgewire from stray electrical energy, uneven thermal expansion of components from external heating, and degradation of explosives from external heating.
- (2) Problems due to temperature have been discussed and ignition temperatures of common explosive materials listed. Supporting studies have been described.
- (3) A probable safe current for all wire bridge devices has been identified as 10 ma.
- (4) The sensitivity of some EEDs to static electricity was examined. Static sensitivities of bulk explosive materials were examined to broaden the base of application to EEDs.
- (5) The results of radio frequency sensitivity tests have shown a maximum sensitivity (minimum power) of 87 milliwatts for 5% firing probability.
- (6) Mechanical test methods for bulk explosive materials have been discussed, and sensitivities for some bulk materials have been listed. MIL STD 322, covering in part the drop test for fuzes requires a 40-foot drop test. Service requirements for some EEDs include 50,000 g acceleration.

Impact and friction tests have been made on a number of explosive materials by Picatinny Arsenal in a test apparatus that bears that name. The test consists of dropping a 2 kilogram weight on an explosive sample contained in a small steel die cup. A similar apparatus and test technique has been developed by the Bureau of Mines. The drop height is given as the sensitivity of a particular explosive and it represents the minimum height at which at least one of 10 trials results in an explosion.

The sensitivity of explosives to friction is determined by exposing a sample of the explosive to the action of a fiber or steel shoe attached to the end of a pendulum. A qualitative explanation is given of the results in the form of explosion (E), snaps (S), cracks (C), or unaffected (U) in decreasing order of reaction.

The results of these tests on some materials used in electric initiators is shown in Table 4.

Table 4

IMPACT AND FRICTION SENSITIVITY OF EXPLOSIVES  
COMMONLY USED IN ELECTRIC INITIATORS<sup>(8)</sup>

<u>Explosive</u>	Picatinny Arsenal <u>Impact Test Drop Height (in.)</u>	Picatinny Arsenal <u>Friction Test Steel Shoe</u>
Lead Azide	3	E
Lead Styphnate	8	E
Cyclonite (RDX)	8	E
PETN	6	C
Tetryl	8	C
Black Powder	16	S

Another form of mechanical energy to which explosives and electro-explosive devices are sensitive is the output from other explosives and explosive devices. This means that if one device in a package is accidentally set off, then the protection provided by the package should prevent continued

propagation of the reaction. High explosives are tested to find critical gap dimensions for barriers that are set between the explosive that provides the impetus (the donor) and the explosive that receives the impetus from the donor (the acceptor). These distances are difficult to compute because of the wide variety of physical constants of the explosive materials (that are usually granular) and because the gap is critically dependent upon the confinement of both acceptor and donor. Directional properties of the explosions, dependent on device design, also have a large influence.

Because of these factors, a limited number of tests were made on the ability of a high-output blasting cap to detonate a small electric detonator. Results are reported in Section 4.4.

## 2.5 Summary of Section

- (1) Predominant failure modes have been identified by cause: Pins-to-Case sparking, bridgewire-to-case sparking, heating of bridgewire from stray electrical energy, uneven thermal expansion of components from external heating, and degradation of explosives from external heating.
- (2) Problems due to temperature have been discussed and ignition temperatures of common explosive materials listed. Supporting studies have been described.
- (3) A probable safe current for all wire bridge devices has been identified as 10 ma.
- (4) The sensitivity of some EEDs to static electricity was examined. Static sensitivities of bulk explosive materials were examined to broaden the base of application to EEDs.
- (5) The results of radio frequency sensitivity tests have shown a maximum sensitivity (minimum power) of 87 milliwatts for 5% firing probability.
- (6) Mechanical test methods for bulk explosive materials have been discussed, and sensitivities for some bulk materials have been listed. MIL STD 322, covering in part the drop test for fuzes requires a 40-foot drop test. Service requirements for some EEDs include 50,000 g acceleration.

### 3. ENVIRONMENT OF ELECTROEXPLOSIVE DEVICES

#### 3.1 General

The environment that an EED experiences during handling and transportation may include a variety of stimuli. Not only are the forms of the stimuli different, but the magnitudes of these may vary within wide ranges. Some of the environments are difficult to describe meaningfully because there is a variable factor, individual device and package design, affecting response to stimuli. Effort will be made in Section 4 to take the design variable into account and to bring together the magnitude of the stimulus and the sensitivity of the initiator.

In the present section the environments that can be experienced will be bracketed with information where available.

#### 3.2 Heat

The heat stimulus that an EED can receive in handling and shipping varies from very low temperatures to very high ones. Some work has been done in recording temperatures of storage bunkers in desert areas<sup>(17)</sup>. Average maximum and average minimum storage temperatures were recorded in storage bunkers at NOTS, China Lake California; NAD, Hawthorne, Nevada; and YPG, Yuma, Arizona. Some of these data were taken over a period from 1957 through 1963. Minimum average temperature was about 32°F at the Nevada site and the maximum average temperature was about 104°F at the Yuma site. Only 3 or four times in the period from 1957 through 1964 did the temperatures in the storage bunkers exceed 115°F. Open shade storage areas were found with maximum temperatures around 110°F. This study claims that the 165°F requirement for storage temperatures is grossly high and unrealistic with apparently enough data to back up this statement as far as practical storage is concerned.



There appears to be little information on the temperature environment of transporting vehicles. Surface temperatures on dark colored automobiles are high enough to prevent prolonged contact with the palm of the hand; these temperatures are probably around 150°F. This does not mean that the entire vehicle storage space or load space is at a high temperature like the surface of the vehicle. Some moderation of the temperature would be accomplished by the cooler bottom and sides of the vehicle. Solar radiation probably accounts for most of the extreme temperatures that will be found in storage areas and in transporting vehicles. The high temperatures resulting from this exposure will probably crest during the mid-day periods during the summer at temperatures higher than those reported in the desert storage study. A guess for the extreme maximum temperature under these conditions would be about 160°F.

Temperatures in excess of 130°F have been recorded in noninsulated or nonrefrigerated freight cars in direct sunlight<sup>(18)</sup>.

### 3.3 Electrical Environment

#### 3.3.1 Lightning Storms

Lightning is the result of an equalization of opposite electrical charges that have been generated by natural processes. By various means clouds in the atmosphere accumulate a rather large charge of electricity that is essentially static, prior to its discharge by a stroke of lightning<sup>(19)</sup>.

Even in the static state, a charged cloud can present problems with explosive materials on the surface of the earth. The charged cloud has what is known as an image under it on the earth plane that in reality is not as perfect as one would be led to believe. Charges of polarity opposite to that of the cloud are attracted from parts of the earth to the points nearest the cloud and hence objects in this area are raised in potential with respect to the average potential of the remainder of the earth. The static field thus generated could cause problems particularly where objects that are well earthed are near objects that are not well earthed. Sudden changes in the condition of the field or in the position of objects thus charged could cause spark discharges even in the absence of lightning strokes.

The magnitude of the electric field is given by: <sup>(20)</sup>

$$E_y = \frac{1.798 \times 10^{10} H Q_o}{(H^2 + d^2)^{3/2}} \quad (3-1)$$

where  $E_y$  is the vertical component of the electric field - volts/meter  
 $H$  is the height of the charge above the ground plane  
 $Q_o$  is the charge on the cloud center - Coulombs  
 $d$  is the distance from the projection of the charge on the ground - Meters

Under average conditions, the electric field immediately under the charge center is over 30,000 volts per meter and at distances of 2500 meters the field is over 6,000 volts per meter. Figure 7 shows the distribution of the electric field with distances for average conditions (height 2000 meters) as well as for very low clouds (500 meters).

Other means of obtaining dangerously high electrical potentials or currents in packaged electroexplosive devices include (1) induced or radiated effects and (2) direct conduction effects from lightning storms.

As breakdown begins from the static cloud center, some of the charge that was formerly on the cloud forms a column from the cloud center to the earth. This phenomena occurs rather slowly but the net effect is to bring the charge closer to the earth's surface with the result that the vertical electric field increases in intensity. The field is computed using the charge left on the cloud and the charge that exists in the column extending from the cloud toward the earth. Under average charge and height conditions, the field will have the values that are shown in Figure 8. <sup>(20)</sup> The time here is shown from the beginning of the leader stroke to the time that the leader approaches the earth. Distances from 0 to 1000 meters are shown. The magnitudes of this field becomes very high as can be seen from this curve.

When the leader reaches the earth, a return stroke forms that may have a velocity of 0.6 that of light. The leader strokes normally have

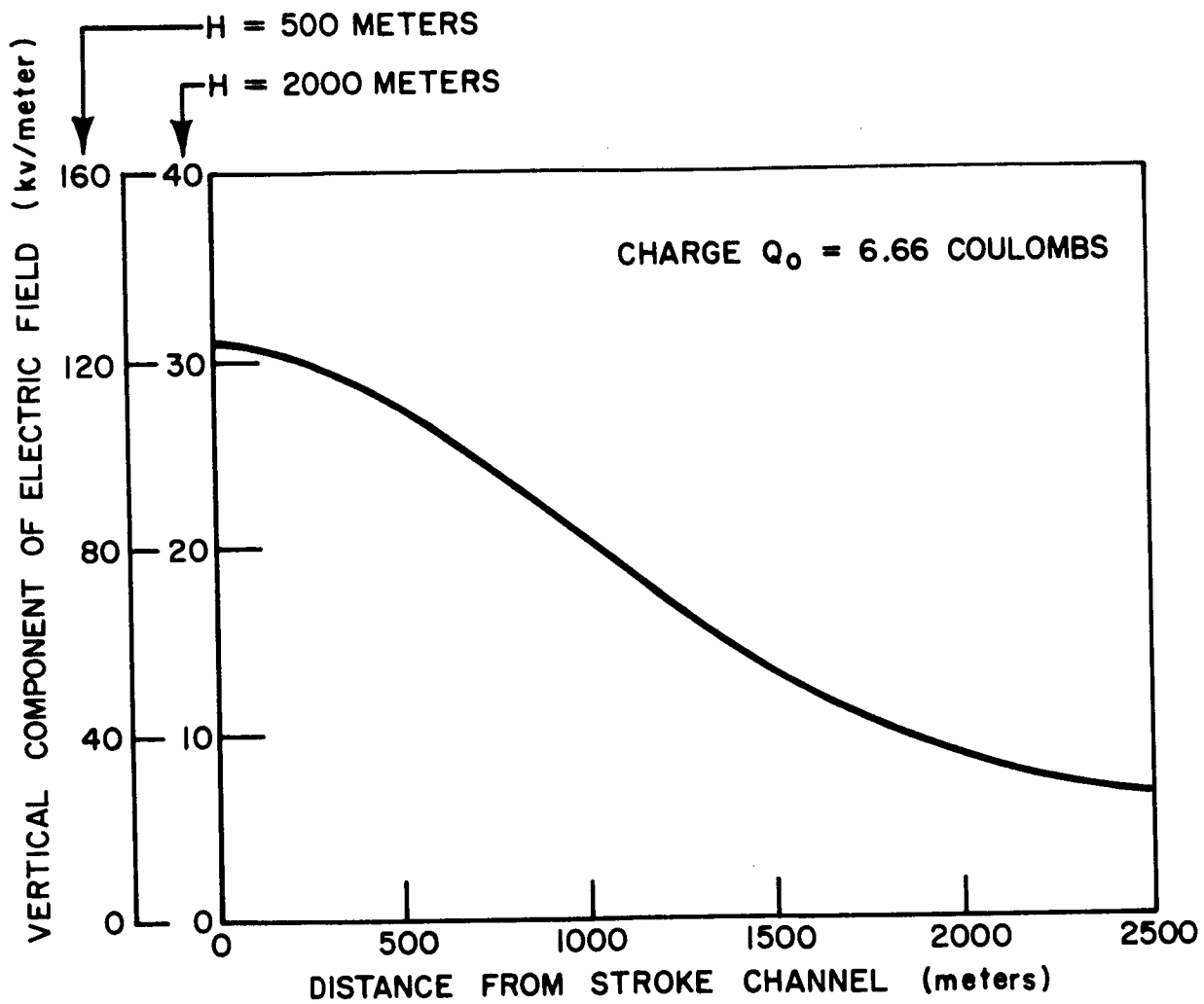

Fig. 7 - Static Electric Field Preceding a Thunderstorm

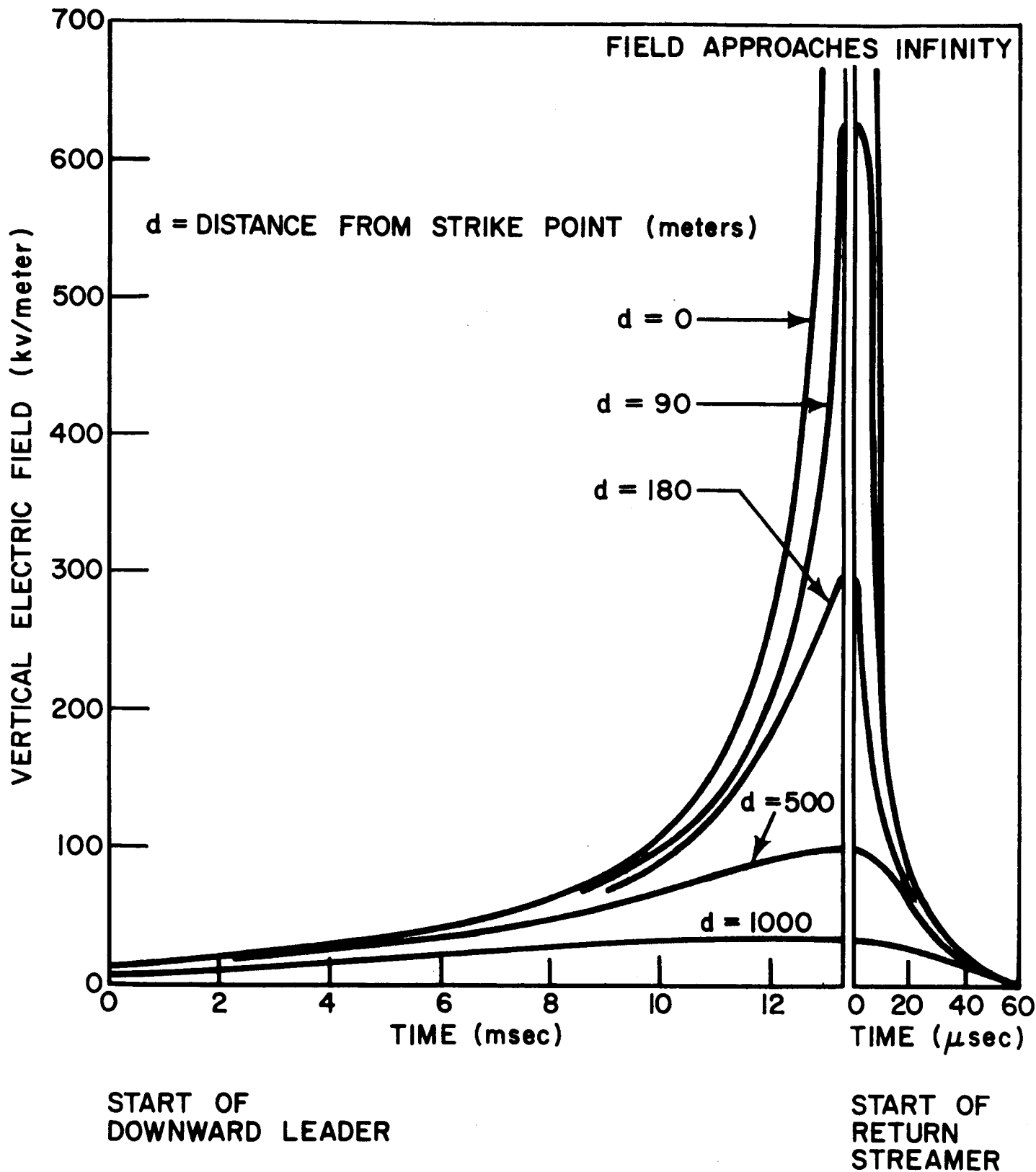

Fig. 8 - Vertical Electric Field During Dynamic Portions of the Lightning Discharge

a velocity only one or two percent that of light. Currents in the main or return stroke are on the order of 10,000 to 30,000 amperes on the average and may attain currents in excess of 150,000 amperes. The result of the main stroke on the electric field is to immediately neutralize it as is shown on the right side of Figure 8.

A second effect of the main stroke is to set up potential gradients in the earth. This is brought about by currents that flow through the earth to the strike point. This radial electric field is the one that probably causes most of the 5000 annual deaths attributed to lightning in the United States. The magnitude of this field is given by:

$$E_r = \frac{2}{\pi} \frac{I_o}{r_o} \frac{v}{v_o} \sqrt{\frac{\rho Z_o}{v_o T}} \sqrt{\frac{t}{T}} \quad (3-2)$$

where

$I_o$  is the maximum current in the main stroke - kiloamperes

$r_o$  is the distance from the main stroke - meters

$v$  is the velocity of the main stroke - meters/second

$v_o$  is the velocity of light -  $3 \times 10^8$  meters/second

$\rho$  is the resistivity of the earth - ohm-meters

$Z_o$  is the characteristic impedance - 30 ohms

$t$  is the time - seconds

$T$  is the rise time of the stroke current - seconds

The phenomena involved in production of the radial electric field and the magnitude of this field as a function of distance for three values of earth resistivity are shown in Figure 9. From this figure it can be seen that the higher electric fields result from higher earth resistivities. Even at a distance of 1000 meters from the strike point the magnitude of the electric field is over 6000 volts per meter.

The main stroke current also produces a magnetic field. The leader strokes produce a magnetic field that is almost infinitesimal compared to that of the main stroke and therefore the main stroke is of most interest

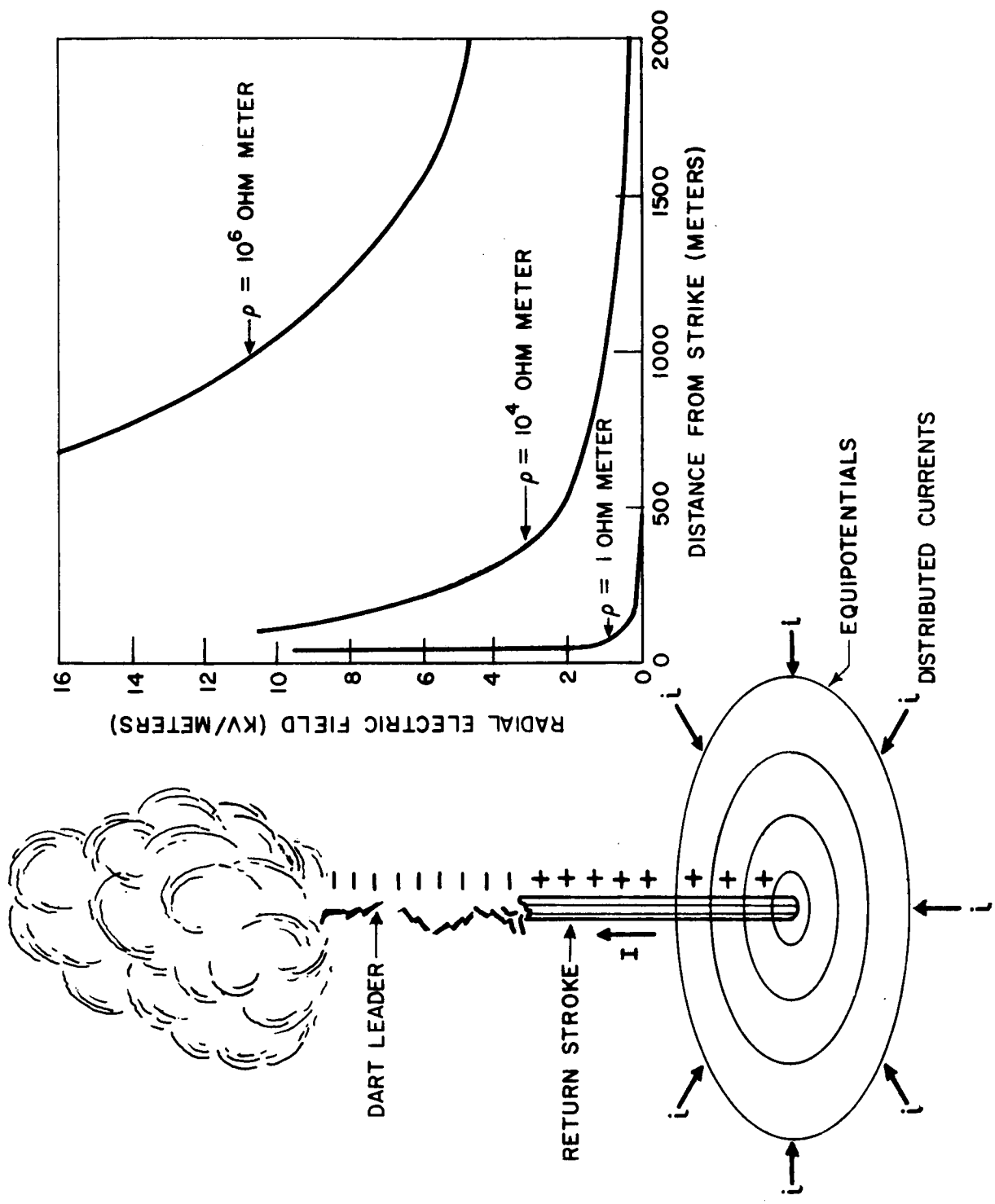

Fig. 9 - Radial Electric Field in the Earth Surrounding a Lightning Strike

in this respect. The magnetic field resulting from the main stroke is given by<sup>(21)</sup>:

$$B = \frac{2 Z_o I_o v \tau}{v_o^2 r_o T} \quad (3-3)$$

where  $\tau$  is the time from the arrival of the leading edge of the magnetic field to the time of interest.

When  $\tau$  is greater than  $T$  this equation does not apply.

The effects of the magnetic field produced from the main stroke is illustrated in Figure 10 which is really a summary of the contents of Appendix A. Shown here is the magnetic field emanating from the main stroke. The magnitude of the magnetic field as a function of time is shown, as is the equation for the induced voltage in a closed loop. Approximations of the potential induced in closed loops of various sizes for a 150,000 ampere main stroke are shown in Figure A-2, Appendix A.

### 3.3.2 Static Electricity

Hazards of static electricity are typified by an accident that occurred on 14 April 1964 at Kennedy Space Center in which 11 were injured - two fatally. The electric delay squib was ignited by static and this caused ignition of an X248 rocket motor. The static charge was generated during removal of a protective plastic cover from the motor.

Static electricity is perhaps a misnomer as this phenomena applies to firing electric initiators. Prior to the time that a discharge occurs, the electric charges are bound on insulating materials or on metallic components that are themselves isolated electrically and are indeed static. Static charges accumulate as the result of bringing two materials close together. There is a contact difference of potential between any two dissimilar materials. This difference is small when contact is made; but as the two pieces are separated from one another, the potential soars because the capacitance is decreased while the charge is conserved. A

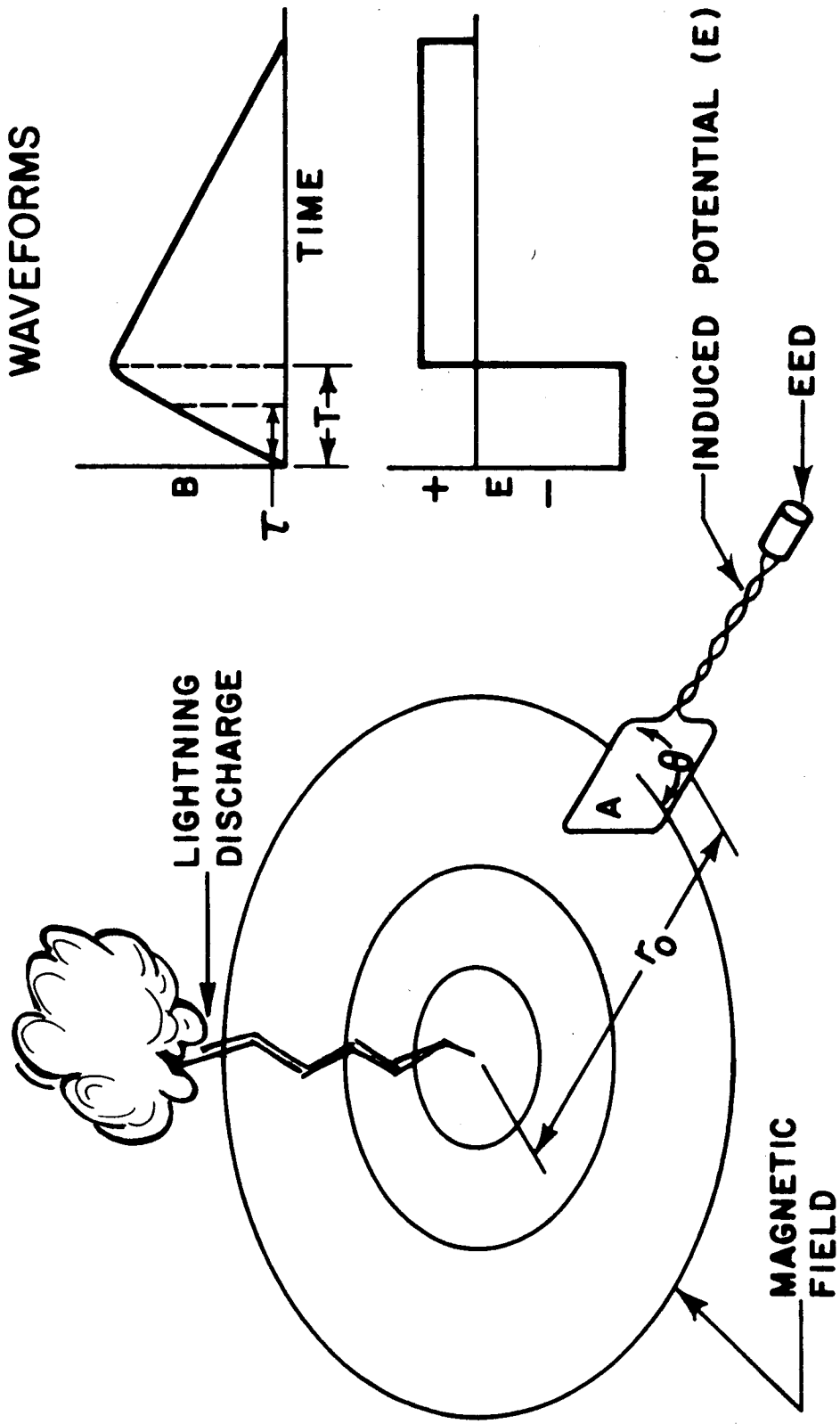

$$E = \frac{-d \int_s \bar{B} \cdot d\bar{S}}{dt} = \frac{-dB}{dt} A \sin \theta$$

$$B = \frac{2Z_0 I_0 V T}{C^2 r_0 T}$$

Fig. 10 - Summary of the Effects of the Magnetic Field from a Lightning Discharge on Electric Initiators



discharge is triggered when the potential becomes high enough. This discharge may contain frequency components into the microwave spectrum.

Contact between two materials is facilitated by work that is done on the surfaces and often is a contributing factor in the generation of static potentials. Storage of the charge that is generated is an important aspect of the mechanism of charge production and transfer. Any object that has mass also has capacity to earth, and it is this capacity that is able to store charges that are generated by static means. In most instances there is enough leakage resistance to the earth to bleed this charge as rapidly as it is generated; and as a consequence of this leakage, there is no appreciable rise in the potential of the object. At times, usually when the relative humidity is very low, the leakage resistance is large and the charge may accumulate to the point that the potential is very high. This accounts for the shocks that one receives in sliding across the vinyl covered auto seats and then touching a metal portion of the auto.

Estimates have been made of the magnitude of the potential that is possible to achieve on the human being and of the capacitance and leakage resistance of the human being under different conditions<sup>(22)</sup>. In addition, transfer efficiency of switching devices to evaluate the electrostatic hazard have been assessed.

The potential that a human can build up is critically dependent upon the shoes that he is wearing and upon the material on which he is standing. Under conditions where the sole of the shoe is a good insulator and rather thick, it is possible to store charges at a potential of 20,000 volts or more; this is exceptionally high compared to average conditions. Under these same circumstances, the capacity would tend to be on the low side; perhaps 100 to 150 picofarads. Capacity is determined by the size of the individual and can be estimated by adding half of the height of the individual in centimeters to the capacitance contributed between the foot and the earth<sup>(23)</sup>. The result will be in picofarads. Actual measurements of the capacity of individuals showed extremely high values of capacity to exist in wet, rainy weather. In one instance the capacity was 1,160,000

picofarads during wet weather. Leakage was apparent, and it was not easy to maintain a charge on the individual due to the rapid decay of charge. Resistance measurements were also made on individuals from wrist-to-wrist, ankle to wrist and from wrist to ground. There were wide variations in individuals and in foot ware. It is generally concluded that 500 picofarads in series with a 5000 ohm resistor is a fair estimate of the human circuit.

Other than human circuits applicable to static safety of EEDs have been given little concern. Many of the conveyances for EEDs are large, insulated from ground, and subject to the generation of static charge either from frictional means or by induction. Consider a 40-foot trailer under the same conditions used to calculate human capacitance. The capacitance of the trailer due to size alone would be on the order of 600 picofarads. Rubber tires contacting the earth are in effect a self-exciting Van de Graaff generator with proper conditions. Air containing dust and sand passing the body of the trailer either due to the motion of the vehicle or to wind can cause the generation of large potentials on the body of the vehicle. The net result of all of these generators could be the accumulation of large potentials, perhaps as high as 30,000 volts on the vehicle.

Often test vehicles used in space research are large and subject to some of the same conditions outlined for the trailer in the paragraph above. Stages of some of these vehicles are large enough to be of significant capacitance to store appreciable energy if the potential is allowed to build up on them.

The environment for electroexplosive devices is hostile in some respects considering the static electric effects. The possibility of generating and storing large quantities of electrical energy is ever present unless proper precautions are taken.

### 3.3.3 Radio Frequencies

Radio Frequency energy includes, when spoken of with respect to EED safety, from what is normally considered audio frequencies through microwave frequencies and even of higher frequency than microwave. It is rather difficult to define the RF environment that may exist at a particular point because of the mobility of existing high-power equipment. It is equally difficult to generalize on the environment that a package of EEDs or an EED being handled may experience without an exact knowledge of the path of that particular EED with respect to some specific transmitter.

Levels of power density are often taken as the human tolerance limit for electromagnetic energy. This value is often taken as 10 milliwatts per square centimeter or 100 watts per square meter (they are the same magnitude of field). One of the standard requirements at the Eastern Test Range is that the vehicles being tested demonstrate ability to withstand exposure to 100 watts per square meter of ambient electromagnetic energy for frequencies of 50 MHz or greater and 2 watts per square meter for frequencies from 150 KHz to 50 MHz\*.

It is possible to obtain the specific frequencies and power densities that exist in a specific area of interest through the Electromagnetic Compatibility Analysis Center (ECAC). The services available from this center are described in a report by that center<sup>(24)</sup>.

Probably one of the most hazardous areas that could be encountered would be right on the base or launch site where EED hardware is received. Here all of the instrumentation, radar and communication equipment that is needed for space exploration is concentrated. It would be well to use the requirements set down for range safety. It is not likely that power densities in excess of these will be encountered elsewhere without foreknowledge that the energy exists.

---

\* AFETRM 127-1, Range Safety Manual, Headquarters Air Force Eastern Test Range, 1 Nov. 1966.

Another example of high concentration of RF emitters and potentially hazardous explosives and fuels is an aircraft carrier during military operations. It is mandatory here that the hazardous components be able to survive the environment for it is not feasible to curtail RF transmission during many combat operations.

### 3.4 Mechanical

The magnitude of the mechanical shock to which a package is subjected is more severe in handling than it is in shipping. These results are pointed out in a study by the National Safe Transit Committees<sup>(25)</sup>. The magnitudes of the shocks received in various stages of shipping by different carriers is summarized below. The magnitudes of the shocks received has been interpreted from graphs in the referenced publication.

Table 5

#### MAXIMUM VALUES OF SHOCK RECEIVED IN SHIPMENTS BY VARIOUS CARRIERS

<u>Carrier</u>	<u>Shock Magnitude (G's)</u>	
	<u>Enroute</u>	<u>Handling</u>
Air	4	10
Truck	5 US or State Highway at 30 to 50 MPH	
	10 Rough Street 10 MPH	9
Rail Freight or Express	6 Normal Travel	
	9 Switching and Car Shifting	9

Thus the normal range of shock that can be expected in a normal shipment is on the order of 10 G maximum. The frequencies that are involved in railroad travel are on the order of 2.5 to 5 CPS.

There is little that can be said about the abnormal conditions that might be met such as that of an accident in any of the vehicles.

It must be assumed that the loads would be of very great magnitude, but estimates of these loads are difficult to make or find in the literature.

Instances of dropping explosives, either packaged or unpackaged, is considered abnormal. Shocks involved in these occurrences are therefore not treated in this section; however the results of drop testing of packages containing typical dunnage material is included in Section 4.4.

### 3.5 Summary of Section

- (1) The maximum temperature to which a package is normally exposed is in the vicinity of 130°F. A maximum temperature requirement of 160°F is believed to be adequate.
- (2) The methods of computing electric fields, magnetic fields and ground gradients resulting from lightning discharges have been presented.
- (3) While 500 picofarads and 5000 ohms is considered as a reasonable estimate of the static circuit for the human being, little has been established concerning vehicles and their effects. Larger potentials than the nominal 20,000 volts for the human are believed possible.
- (4) Radio frequency hazards are discussed with the result that potentially hazardous conditions exist.
- (5) Maximum acceleration applied in normal shipment by air, highway or rail is 10 g.

## 4. RESPONSE OF ELECTRIC INITIATORS

### 4.1 General

In Sections 2 and 3 we have discussed the sensitivity and the environment of electric initiators in the process of shipping and handling. The magnitudes of these alone do not normally constitute a hazard unless the energy available from the surroundings is delivered in such a manner that the device can be activated (fired) or otherwise affected. Often there is a very small margin of difference between the level at which firing occurs and the level at which an EED can be adversely affected by energy input.

We will attempt to define the conditions prevailing today in shipping and handling by considering transfer mechanisms of the environment to the EED. In most instances, while numerical values may be attached to the phenomena, the results are best estimates and should be treated as such. Conscious efforts will be made to keep the results on the safe side. In this section, Section 5, and in Appendix C results of the study will be brought together.

### 4.2 Heat

From examination of the heat sensitivity of EEDs and of their constituents and from examination of the temperatures that exist in storage bunkers and in some modes of transportation, it appears that there is little need to be concerned with problems of heat causing explosive reactions or adversely affecting electric initiators. The storage of explosives, in general, in temperatures that are moderate is a good plan; but there appears to be little real need to be concerned over temperature in normal shipping and handling if all devices are qualified to 160°F\*.

---

\* MIL-STD 322, Basic Evaluation Test for use in Development of Electrically Initiated Explosive Components for Use in Fuzes, 15 Oct. 1962, Sec. 5.2.9, p.6.

Existing packages for blasting caps are required to have dunnage similar to sawdust that will probably be an insulator equivalent to or or better than sawdust. This type of dunnage will tend to round off any very high short-duration temperatures to which the package could be subjected, but there appears to be no pressing need, even for this minimal form of protection, in light of the existing information on sensitivity and environment.

Devices may exist that are not "characteristic", or conditions may occur that are out of the ordinary. It is for this reason that suggestions are made concerning temperature monitoring of the package and for thermal testing of devices that are built for NASA use. These practices outlined in Section 5 and Appendix C are calculated to minimize losses and malfunctions due to exceptional conditions.

Fires in the vicinity of a package containing EEDs are an exception to the discussion above. Most existing methods of packaging provide no protection for the devices in as far as reliability is concerned. Most of the boxes and dunnage materials recommended will themselves burn. It is understood that the Bureau of Explosives tests packages in a "bonfire test" that proves the worth of a package to contain an explosion thus generated or to minimize its effects.

#### 4.3 Electrical

Electrical hazards are one of the most undetectable and unpredictable type that the person concerned with packaging and handling EEDs can face. Heat and mechanical excitations can be either seen or sensed by feel or hearing, but the electrical hazards can not normally be detected by the senses. This factor is one which makes them most feared and least understood. We shall consider only briefly here the means by which electrical energy can become a hazard and provide a number of references for further information and study. This region has been and is currently being investigated extensively by Government agencies and their contractors.

#### 4.3.1 Responses to the Lightning Stimulus

Lightning becomes a hazard to electroexplosive devices in at least five distinct ways. Each of these have to do with nature of the lightning process that was discussed in some detail in Section 3.

- (1) The static field that exists under a cloud center
- (2) The dynamic electric field that occurs during the leader and main stroke portions of the discharge
- (3) The dynamic magnetic field that emanates from the return stroke
- (4) The electric field that is set up in the earth as a result of the main stroke current
- (5) Direct conduction of the current from the main stroke

The static field is perhaps the minimum hazard of the five mentioned because there is little energy brought to bear on devices that are on the surface of the earth. Even relatively poor grounds prevent the accumulation of charge. Objects that are well insulated from ground can acquire potentials that depend upon their size, conductivity, leakage resistance to earth, and shape among other less-important variables. The smaller an object, the smaller its capacitance and hence the shorter the time required to build to a given potential. If a small object is in the vicinity of a large object and both have approximately the same other characteristics, the smaller object will acquire a higher potential than the larger one at the same time. The result is that there is a potential difference between the two objects. If these objects are close enough together, a potential difference could build between them to the point that a spark discharge could occur. The spark will result in redistribution of the charges and current flow in the objects.

The forementioned charges that accumulate on ungrounded objects redistribute quickly when the leader and main stroke lightning discharges occur. The result of the rapid change in the field surrounding objects is often accompanied by sparking. Fires have been started in wooden barns



as a result of sparking between nails holding surface boards on the barn<sup>(26)</sup>.

Since sparking has been shown to be produced between close, small metallic objects at distances of one half mile, there is need to consider the effects of this field on electroexplosive devices, even those that are inside of conventional packages. The main concern here is for sparking that could occur between the leads and case of the device as a result of the electric field.

The magnetic field resulting from the main or return stroke is one of the most serious threats to most EEDs because of the intensity and rapid change that this field undergoes. An approximate analysis of the results of this field is contained in Appendix A. While some of the assumptions made in this analysis are inexact, it has been shown by others that this causes little error. This is supported by Equation 3-3 that describes the magnetic field as a function of time and distance. The importance of parameters introduced into the EED package are pointed up in Appendix A.

It is not possible to predict what will happen to the individual EED without sensitivity information corresponding to the exposure time of interest and this time extends from one microsecond through 500 microseconds for lightning discharges. Either constant current or constant voltage sensitivity of the EED in this time range of interest is essential to the evaluation of the hazard from dynamic magnetic fields that are the result of the return stroke of a lightning discharge. There is virtually no information on the sensitivity of EEDs used by NASA in this time range.

Assuming the worst case condition, that of the most sensitive wire bridge device that is known in this realm of time, the "no-fire" current is on the order of 200 milliamperes. With a resistance of one ohm in the entire circuit a finite probability of firing would begin to occur at 0.2 volts. This potential would exist at 100 meters from a strike in a loop area of 0.01 square meters. Repeated strokes cause additional concern and could stack thermally if the thermal time constant is long enough.

The ground gradient resulting from a lightning strike creates potential drops across portions of the earth. If any part of the EED is in direct contact with the earth, or if there is a small gap between the EED and the earth, then there is a chance that a portion of the energy from the ground currents will be diverted through a vulnerable portion of the EED. Potential differences of over 16 KV for each meter of earth can be experienced depending upon the earths resistivity in the area of the strike.

The ground gradient can exist at relatively large distances from the strike point. This makes handling of EEDs during lightning storms particularly hazardous and foolish. There is the distinct possibility that large current surges can be generated during this time due both to the field itself and due to the possibility of connecting the EED so that it includes a portion of the earth in the circuit.

Packaged EEDs, in general are safer than those with extended leads or connected to incompletely shielded circuits. Sharp ends on the leads or on the EED case would tend to make the devices more prone to acceptance of a discharge from the potential of the earth gradient. In this instance as well as in a number of others, it would be desirable to use a foil enclosure for the packaged EED.

A direct strike of lightning on a package of initiators would result in currents and voltages in the devices that would be difficult to define. It is nearly certain that at least some of them would be fired. Experiments to provide better knowledge in this area are now possible using natural lightning it would seem by triggering lightning from storm clouds by means of rockets trailing wires. This has been done by the Lightning and Transient Research Institute.

Direct strikes on conventional aircraft in flight have resulted in damage ranging from very light to extensive, depending upon the location hit among other factors. Usually troubles occur in the metal skins, in the

metal-plastic or pure plastic structures, or across poor bonds. In short, the trouble occurs whenever the target material has a reasonably large resistance. Natural lightning strikes have caused holes up to 4 inches in diameter on aircraft skins.

It would seem that even with a direct lightning strike, explosives with a thick low-resistance casing would be reasonably safe insofar as the initiator itself is concerned. If thin-walled charge containers are used, such as is used on some of the lead and plastic enclosed linear charges, intermediate explosive such as PETN and RDX could probably be detonated.

The effects of lightning discharges on the internal portions of simulated rockets and spacecraft structures has been under study in the Lightning and Transients Research Institute<sup>(27)</sup>. The work of this group included experiments on a cylindrical vessel of aluminum with a wall thickness of 90 mils. This vessel was subject to energy from the discharge of a generator capable of delivering current surges up to about 100,000 amperes. Surges were delivered either through a sending probe that consisted of a straight grounded conductor parallel to the cylindrical axis of the vessel or by a direct discharge through the cylinder from the top surface. Fields inside of the cylindrical vessel were checked with a loop 10 cm in diameter connected to a Tektronix 321 oscilloscope.

An analysis indicates that fields inside the cylinder are the result of either a conductive voltage drop on the inside of the wall or a combination of the mutual inductance between the wall and some center conductor, and the self-inductance of the wall. If the wall and the conductor are coaxial, the voltage appearing between the bottom of the center conductor and the wall is given by  $(L-M)(di/dt) + iR$ .

where

$L$  = inductance of the shield in henrys

$M$  = mutual inductance between inner conductor and shields in henrys

$i$  = current flowing through the shield in amperes

R = resistance in the shield in ohms

t = time in seconds

In this ideal case  $L = M$  because of perfect mutual coupling between the cylinder and the conductor. It was demonstrated that in the practical case there are discontinuities in the wall due to joints, holes and access ports that cause L and M to be equal.

Practical experiments were run to show that there were indeed fields within the cylinder. With a top cover bolted onto the cylinder and with a butt joint between the two halves of the cylinder, a number of measurements were made with the instrumentation described earlier. Passing a current of 70,000 amperes through sending probe or through the cylinder itself resulted in the delivery of a voltage pulse inside the cylinder that showed ringing, decaying exponentially with time. Maximum voltages of 100 millivolts appeared on the loop, at the point where the cover was joined to the wall of the cylinder. This was true whether the current was applied through the sending probe or through the wall of the cylinder. The amplitude of this signal could be reduced by improving the contact of the joint between the cylinder wall and the cover. Tighter bolting resulted in a substantial reduction of the signal and "Heli-arc" welding of the top reduced the signal by an order of magnitude. Near the bottom of the welded tank, the loop signals were on the order of 260 millivolts. The bottom of the tank was open in this case. Increasing the distance between the sending probe and the tank resulted in a drop in induced voltage, according to a distance function somewhere between linear and square law.

Penetration of energy near a 2-inch diameter hole in the wall of the cylinder resulted in a maximum induced voltage of about 100 millivolts.

All of these investigations on the penetration of energy through the wall are interesting but they do not demonstrate whether explosive devices are safe within the confines of metal cases subjected to direct discharge. With the loop size used and with the instruments described, and because

the loop itself probably has a very low impedance, the potentials indicated are probably the open-circuit potentials of the loop. The power delivered to a one-ohm load resistor would be no greater than about 90 milliwatts, and would be a few milliseconds in duration at the most. Under these conditions there is little need to be concerned for the safety of most electroexplosive devices or for other cased charges. However, larger pick-up loops or larger openings in the wall could prove hazardous. There was sparking observed on the inside wall of the cylinder near joints in the surface. This could well present a problem if the lead wires of EEDs were to contact the inside wall of the cylinder.

#### 4.3.2 Response to Static Discharges

Static discharges most probably account for the largest percentage of accidental initiations of EEDs. The accounts of accidental initiations date back to at least 1954.<sup>(28)</sup> Most of the reports of accidents at this time were with the use of carbon bridge detonators that are generally more sensitive in the bridge mode than are wire bridge devices in the pins-to-case mode.

Devices have been fired with potentials of less than 1000 volts from 500 picofarad capacitors. Indications are that many areas concerning the static sensitivity of bulk explosive materials as well as electric initiators are still in need of research and development. We are uncertain of the complete mechanism involved in the detonation or initiation of EEDs by static.

The electrostatic hazard comes about whenever there is a charging source, a location for storage of the charge that is generated, and a means of switching the stored charge into the EED. Energy levels in the hundreds of ergs must be considered potentially hazardous to EEDs even though some of them will withstand much more. It is difficult to predict the efficiency with which energy can be delivered from a charged source to the explosive. If we consider perfect transfer efficiency, then

the body with a capacitance of 500 picofarads needs only be charged to a potential of 200 volts to deliver an energy of 100 ergs.

Charging sources have generally been found to involve some highly insulating material, usually in thin films. Generally these materials have been of plastic or other synthetic material. It is possible to remove charge directly from such materials by approaching them with sharp objects such as the shorted leads of twin-lead initiators.

Normally most plastic materials have a surface resistivity as high as  $10^{20}$  ohms per square<sup>(29)</sup>. Furthermore, plastics by their nature, tend to flow and make good surface contact with other materials that exhibit a contact difference of potential. Harder materials such as metals, concrete, wood and plaster create large surface contact areas when pressed against plastic materials. For these reasons plastics are noted to be static producing. Two properties of the plastics that contribute to the charge accumulation are (1) their participation in the formation of the charge by having good rubbing contact and relatively high contact difference of potential with other materials (2) their retention of a charge for extended periods of time.

Insulating materials like plastics may contain a number of charge domains on a single surface. These domains may have either polarity and for this reason it is possible to obtain a discharge across the surface of the material as it is moved. Many of us have observed spark discharges of this type when removing clothing of synthetic material in a darkened room.

The measure of the time that a charge can be retained on the surface of a plastic material is used to determine the surface resistivity of plastic materials. Research in this direction was prompted by the accumulation of unsightly films on clear plastics from atmospheric contamination. Reduction of the surface resistivity from the nominal  $10^{20}$  ohms per square has been found to reduce decay times from several months to several minutes. Reduction of surface resistance has been accomplished by the addition of antistatic elements to the plastic in the formulation stage, just prior to the molding;

and treatments of the formed plastic materials have been used with success in an effort to reduce surface resistance. Some of these treatments are water soluble and subject to deterioration with time and use. On the other hand, some are claimed to be reasonably unaffected by exposure to moisture and wear.

Plastics may be made conductive by the addition of conductive fillers such as graphite or silver to the material in the liquid or nearly liquid stage<sup>(25)</sup>. These fillers often change some of the physical properties of the plastic to the extent that they are of restricted use. The conductivity of the composite materials is usually high (low resistance). Some of these have resistivities of 5 ohm-cm with carbon fillers and as low as  $10^{-4}$  ohm-cm with a silver filler. The use of conductive fillers results in drastic changes in the material properties.

Antistatic plastics are made with an agent that renders them conductive to a limited extent (resistivities of  $10^5$  to  $10^{12}$  ohm-cm). The electrochemical changes introduced cause minimal changes in other physical characteristics.

Assessment of surface resistance is made by applying two conductive strips of silver paint to the surface of the plastic. The antistatic coating is applied to the surface left between the two conductive paint strips. The strips will have a capacity that can be measured or calculated. A potential is placed between the two strips and the potential source is removed. The time for this potential to decay to 37% of the initial value is measured. At this point the time is equal to the product of the resistance and the capacitance. The resistance can then be computed and the resistance of the surface expressed in ohms per square by knowing the surface area between the two conductive strips.

Ratings of surface resistance have been stated in terms of the desired results for the plastic industry and for what can be obtained with commercial antistatic compounds. A "poor" rating represents a resistance of over  $10^{16}$  ohms per square and a "good" rating less than  $10^{10}$  ohms per square<sup>(30)</sup>. There are some reservations about the desirable levels of

resistivity for use in the packaging of electroexplosive devices and further consideration is warranted.

Some experiments with conductive plastic materials were made; these are reported in Appendix D.

#### 4.3.3 Response to Radio Frequencies

RF hazards are more difficult to analyze than most others because of the many complex variables that affect the way that energy is extracted from the RF field and transferred to the EED. Considerable background is needed in electromagnetic field theory and antennas to analyze a potentially hazardous circuit or to recognize that one is present.

Because of the nature of antennas and associated circuits, they are sensitive to frequency and subject to resonances, not only in the antenna element, but also in the leads connecting the antenna to the EED. In a general analysis, where the conditions of the transmitting source are not known, the circuit is usually treated as though it were at resonance, perfectly matched, and not subject to losses. This type of analysis is known as "worst case". It is a conservative approach to systems analysis. General methods of analysis using this approach are available from a number of sources<sup>(31,32)</sup> and the methods used will only be summarized here.

Generally a parameter known as aperture is used in expressing the ability of an antenna system to extract electromagnetic energy from a field. The aperture (A) in square meters is defined as the ratio of the power (W) in watts delivered to the load to the ambient power density (P) in watts per square meter<sup>(33)</sup>. When conditions are optimized, as we stated earlier, then the aperture is known as maximum effective or  $A_{em}$ . Effective aperture or  $A_e$  requires equal and opposite reactances in a circuit but allows for differences in the real portion of the antenna and load impedances.

Specific conditions for packaged EEDs are generally restrictive. Limitations are generally imposed because of economic considerations of



package size. Normally EEDs are either of the twin lead or connector type. Twin lead EEDs may have leads up to 15 feet or even longer, but leads this long are usually folded or rolled to a smaller dimension so that they can be packaged and shipped economically. Net or effective lead length in the package is seldom more than about 15 to 23 cm.

In a previous study<sup>(34)</sup> it was shown that the maximum directivity  $D_m$  of three antennas; the unterminated rhombic, the long wire and the circular loop; can be expressed as

$$D_m = 1.3 L \text{ except for } L \text{ less than } 2 \text{ when } D \cong 1.5$$

where  $L$  is the overall lead length in wavelengths

The maximum effective aperture  $A_{em}$  of any lossless antenna is

$$A_{em} = \frac{D\lambda^2}{4\pi}$$

where

$D$  is the directivity and

$\lambda$  is the wavelength

The directivity equation indicates that as the frequency decreases, the maximum directivity drops to 1.5 for a fixed length such as we have assumed.

The equation for maximum effective aperture indicates that the aperture increases as the square of the wavelength. This is not true for the effective aperture where a specific value of directivity and length can be stated. Where there is a fixed length, the maximum aperture will occur at frequencies with wavelengths comparable to that length or at frequencies higher than the one of first resonance. For these higher resonances, the directivity increases but the wavelength decreases.

The maximum aperture in this instance will be approximately 0.1 square meters. Resonances may occur at frequencies greater than the first resonance in which case the directivity would be greater and the wavelength would be smaller.

Indications are that the most hazardous frequency for packaged EEDs will be around a maximum wavelength of 23 cm. This depends upon a number of factors, but primarily upon the length of the antenna in question. The frequency to be most concerned with then is on the order of 1300 MHz or higher while the device is in the package. When the device is unpackaged and being handled, then the situation changes and the analysis must become more general<sup>(15)</sup>.

Protection in the form of shielding for packaged devices will be adequate for microwave frequencies if it is adequate for the lightning condition mentioned in Section 4 and in Appendix A.

Connector type EEDs have been shown to be most vulnerable when the direction of propagation is along the axis of the connector<sup>(32)</sup>. Power delivered to the EED in this case is no more than that of an equivalent opening in an infinitely large conducting plate.

Generally the maximum aperture is no greater than 1.1 times the area of the entrance port of the connector as long as the perimeter of the opening is greater than three wavelengths. When the hole dimensions are about the same as the wavelength, then the aperture could approach 1.7 times the hole area. Normally the dimensions of the connector are on the order of 1 cm or less and the aperture is on the order of .00013 square meters. Fields on the order of 100 watts per square meter would therefore deliver no more than about 13 milliwatts to the device; no problem.

For small loops, such as those often encountered in EEDs that have been shorted for shipment, the effective aperture is given by:<sup>(33)</sup>

$$A_e = \frac{46700 A^2}{\pi \lambda^2 R_T}$$

where

$R_T$  = the terminating or bridge wire resistance -ohms

$A$  = the loop area - square meters

$\lambda$  = the wavelength - meters

Conditions that apply to the validity of this equation are that the radiation resistance is zero, the loop dimensions are very small with respect to the wavelength, a conjugate match of the reactances of antenna and load exists, and that alignment of the loop with respect to the field is for maximum power to the load.

Under typical package conditions, the area of a loop could be on the order of 20 square centimeters (.002 square meters), and the maximum wavelength under which the loop equation should apply would be on the order of 0.5 meters (based on a wavelength 10 times one side of a square with an area of 0.002 square meters). The effective aperture under these conditions, assuming a bridge resistance of 1 ohm, would be about 0.25 square meters. The power delivered to an EED under these conditions would be 25 watts with an ambient power density of 100 watts per square meter.

Most of the currently used EEDs fire with power levels that are below 1 watt and indications are that help is needed here. Thankfully, as was indicated in Section 3, the areas that lead to this kind of power densities are few, and conditions leading to maximum aperture are seldom met at the same time. In several instances, however the experimentally determined aperture and the effective aperture have been in agreement within one order of magnitude or even closer<sup>(35)</sup>.

Help is required in this area if we are not willing to take the risk of some unexpected initiations of devices in shipping and handling. Protection of the EED is required in the form of built in attenuation or in the form of shielding for shipment followed by inspection of radiation hazards that may exist in certain areas where power densities are high. Scheduling of "on" times for radiating equipment may be necessary where there proves to be a hazard or where one is expected.

#### 4.4 Mechanical Response

It is most probable that the mechanical response of electric initiators varies widely from device to device. It was mentioned earlier that little known about the specific response characteristics of specific devices.

Recently an explosive bolt was detonated by vibration levels on the order of 15g at 300 to 900 cps\*. While the magnitudes of vibration normally encountered in transportation are not this great, the differences in magnitude are too small to ignore them completely. There is need to be concerned with the safety and reliability of devices that show sensitivity this close to ambient conditions.

There is some concern over the magnitude of shock that is imparted to EEDs in the process of shipping and handling. There are also the effects of vibration during shipping that we feel are extremely small in all of the cases known to us. Most of the vibrations that are encountered on transporting vehicles are in the near insignificant range of magnitude compared to some of the flight qualifications that are imposed by NASA. Vibrations and shocks in railway, aircraft and motor vehicle transportation are normally less than 10g and of reasonably low frequency.

Dropping of a package onto a hard surface could mean higher acceleration and greater shocks. In order to learn the approximate magnitude of the acceleration that an EED could receive upon dropping a package, we did the following. Instead of placing an EED in the package we placed a Columbia Model 508 accelerometer in the dunnage material. Two packages were tried. One was a metal can about 10 inches in diameter and about 12 inches deep, and the other was a wooden box about 8 by 12 by 20 inches. We had received EEDs in each of these packages earlier. The dunnage used for this test was brown paper-like material, packed to just fill the portion of the container not occupied by the accelerometer.

The output leads of the accelerometer were connected directly to the probe (10 to 1) of a Tektronix 535 oscilloscope. A number of drops were made with each of the two containers while changing the drop height. A recording was made of the acceleration as a function of time by photographing the oscilloscope trace. Records were later examined for peak acceleration. Results are plotted in Figure 11.

---

\*This work was carried out in the Pyrotechnic Research Facility, AMPD at NASA Langley Research Center, March 1967.

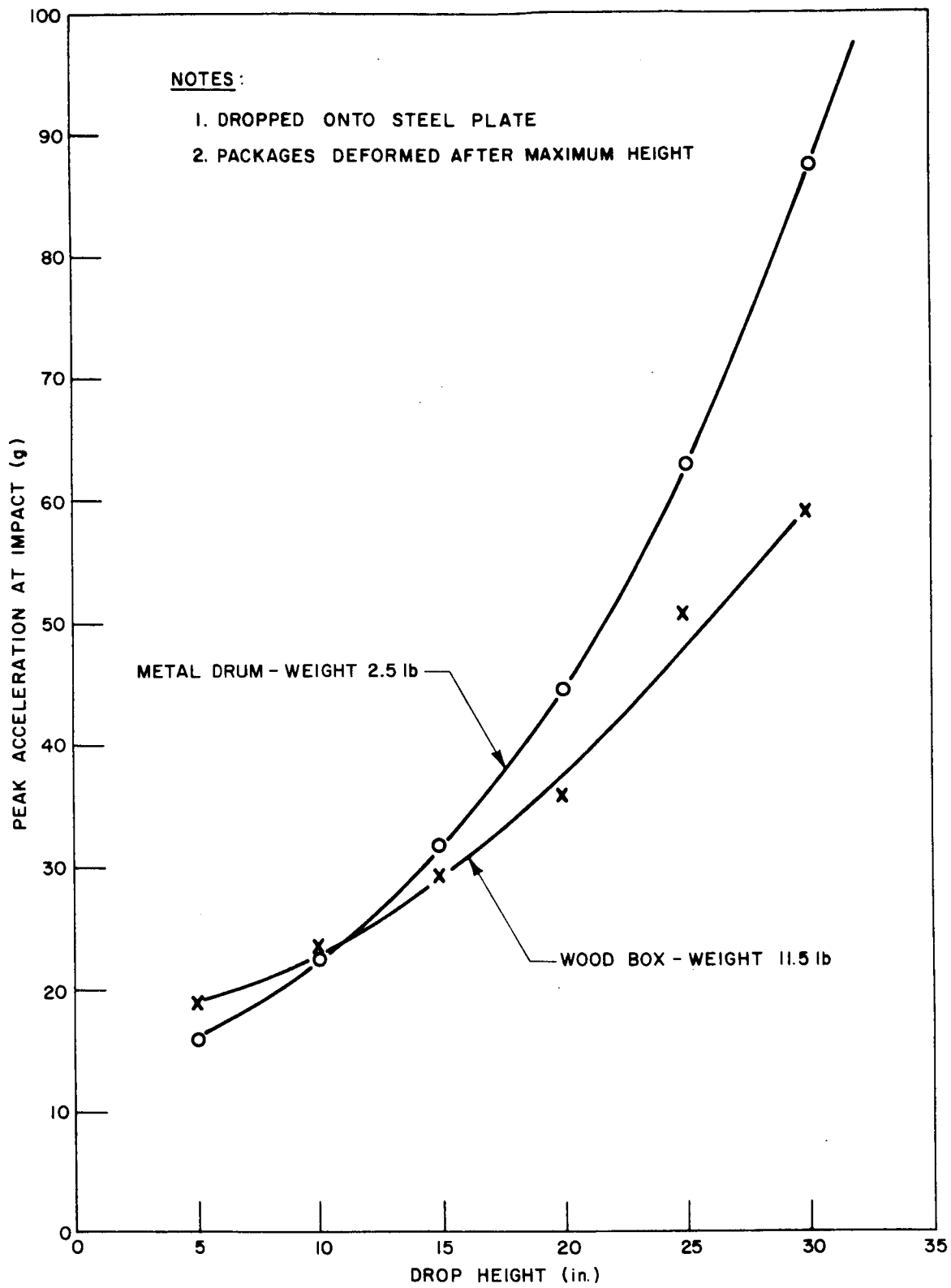
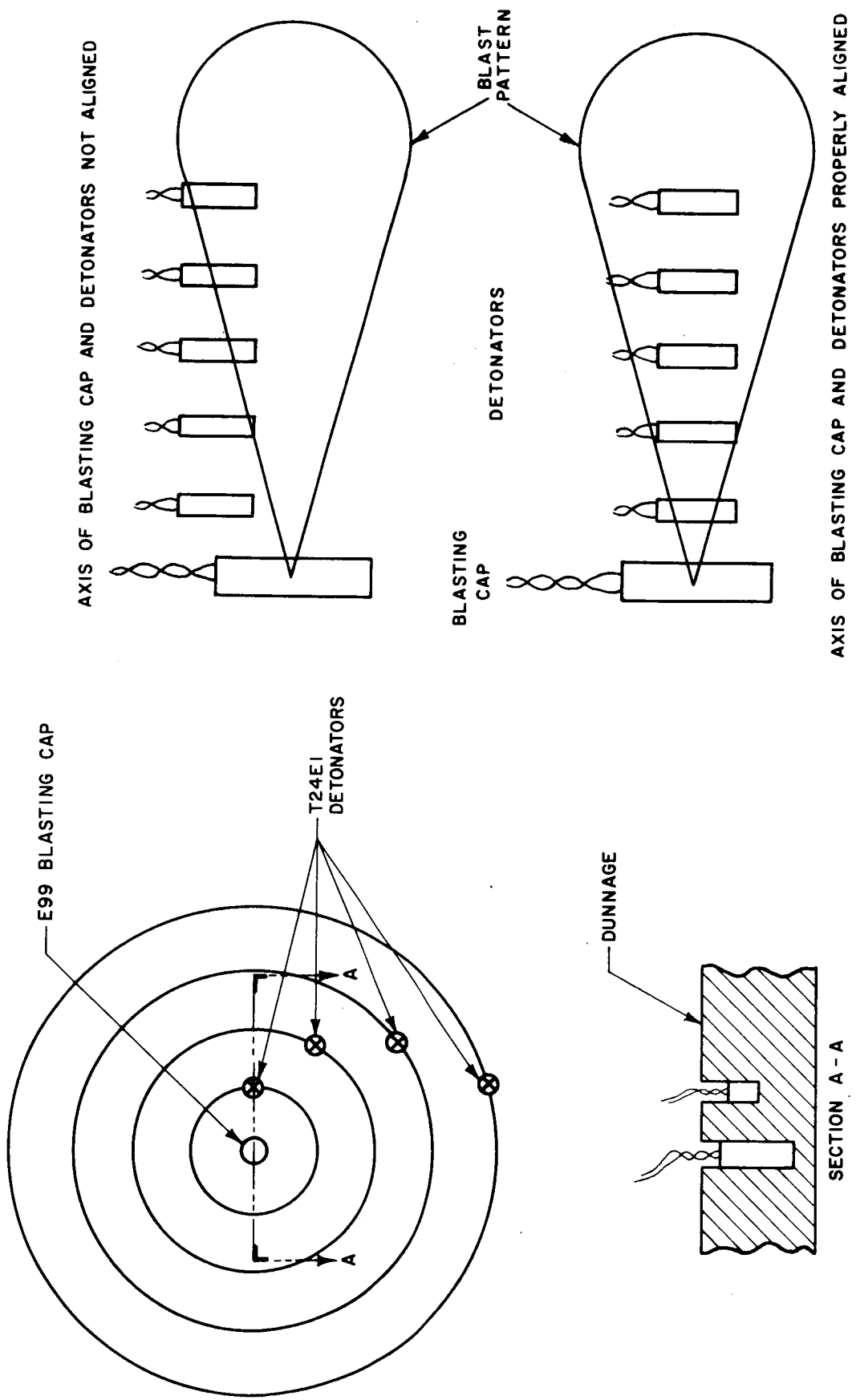

Fig. 11 - Shock Acceleration of Conventional Packages of Electroexplosives at Impact



(A) NORMAL LAYOUT

(B) EFFECT OF BLAST PATTERN OF BLASTING CAP ON DETONATORS

Fig. 12 - Layout of EEDs for Propagation Tests in Packaging Dunnage

It can be seen that there is an ever increasing slope on both of these curves and that the wooden container appears to impart about 30% less acceleration to the simulated EED than the metal package. It is always dangerous to extrapolate information but if we were to do so here, packages dropped from a height of 40 feet or more would still be within a safe range according the criteria that acceleration not exceed 10,000g.

In design of a package to preclude damage, consideration is given to the individual needs of the system. The acceleration that is imparted to the packaged mass under the most severe conditions expected is reduced by the selection of dunnage material that will deform below the damage level of the packaged product. The procedures for this method of analysis are available in a number of sources in the literature<sup>(1)</sup>. Unfortunately, complete data for design of EED packaging are not available.

One of the more serious problems that could conceivably be encountered by a package is that of explosive propagation. That is, if one device is activated unintentionally, the others may fire also and in the worst case might all fire at once. Information is very meager on what can be expected to happen under any given set of circumstances without actually trying the condition in question.

The various types of output of electroexplosive devices compound this problem. The needs connected with damage and other protection to prevent propagation appear to narrow themselves slightly according to the following types of output.

1. A high-order detonation with accompanying shock wave, heat and high velocity case fragments.
2. A "soft" or mild explosion such as that from a squib with lower velocity fragments, hot burning explosive and moderate but long-lasting pressure.
3. Intense, long-lasting heat from charges identified as coruscating.

In the first class would be devices such as blasting caps, detonators and explosive bolts. In the second group would be primers, squibs and activation cartridges. The third class would contain such devices as jet charges, igniters and flares. The same kind of package may not be the optimum one for all of these three classes of output.

Concerned at the moment with the first class of devices, we evaluated the effects of different dunnage material on propagation by setting off a DuPont E99 blasting cap at the center of an array of T24E1 detonators arranged around the periphery and at various distances from the cap using the layout illustrated in Figure 12A. The E99 blasting cap contains 1 gram or more of high explosive material and the T24E1 detonator contains 70 mg of PETN, 60 mg of dextrinated lead azide and 5 mg of milled lead styphnate.

For each test T24E1 detonators were spaced at one-inch intervals from the center of the array but in such a way that one device would have minimum interference with effects of the blast. The results are illustrated in Table 6.

Table 6

## EXPLOSIVE PROPAGATION TESTS IN DUNNAGE MATERIALS

Distance from Center (in.)	1	2	3	4	5
<u>Packing Material</u>					
Crepe Paper	x	x	x	0	0
Vermiculite*	0	0	0	0	0
Tightly Wound Newspaper	x	x	x	x	0
Foam Rubber (white)	x	0	0	0	0
Rubberized Hair	0	0	0	0	0
Styrofoam block	x	x	x		

x - indicates fire

0 - indicates no fire

\* Two samples at each position



More detailed tests were made than can be simply presented. On the foam rubber, detonators were spaced each 1/4 inch up to 1-3/4 inches one was placed at 1.4 inches. The one at 1.4 inches fired and the remaining six inside this location did not fire. The three beyond this location did not fire. This left us with a slight puzzle that was soon solved. The pattern of the output of the blasting cap is apparently doughnut shaped about the center of the longitudinal axis, as is shown in Fig. 12B. A repeat of the experiment with better alignment of the cap and the detonator gave the results shown in Table 6. Additional detonators were fixed at 1/4, 1/2, 3/4, three at 1 and one at 1.5 inches, all of which fired. Three at 2, one at 3, and one at 4 inches failed to fire.

A sample 2" x 4" of foamed aluminum was received by courtesy of the Foamalum Corporation. This material is relatively new and considered to be highly absorbing for impact applications. An experiment was made with this material by drilling holes in it as shown in Figure 13. An E99 blasting cap was placed in the center hole as shown in the figure. T24E1 detonators were placed in the three holes to the right and S94 squibs in the three holes to the left. The distances to each of the devices from the blasting cap were 1/2, 1 and 1-1/2 inches. Both the T24E1 and the S94 located at 1/2 inch from the cap fired. While both of the devices at 1-inch were dented, neither of them fired. Neither of the devices at 1-1/2 inches fired, nor were they visibly affected. Considering the possibility of using more solid material between sections of a package, we tested some polycarbonate plastic materials that were available. These materials are now in use for such applications as street-light covers in areas where stones are apt to be thrown at the street lights. These materials are tough and appear to fail in much the same manner as a metal.

Figures 14 through 17 illustrate the effects of setting off a T24E1 detonator inside various configurations of this type of plastic identified in Table 7 below.

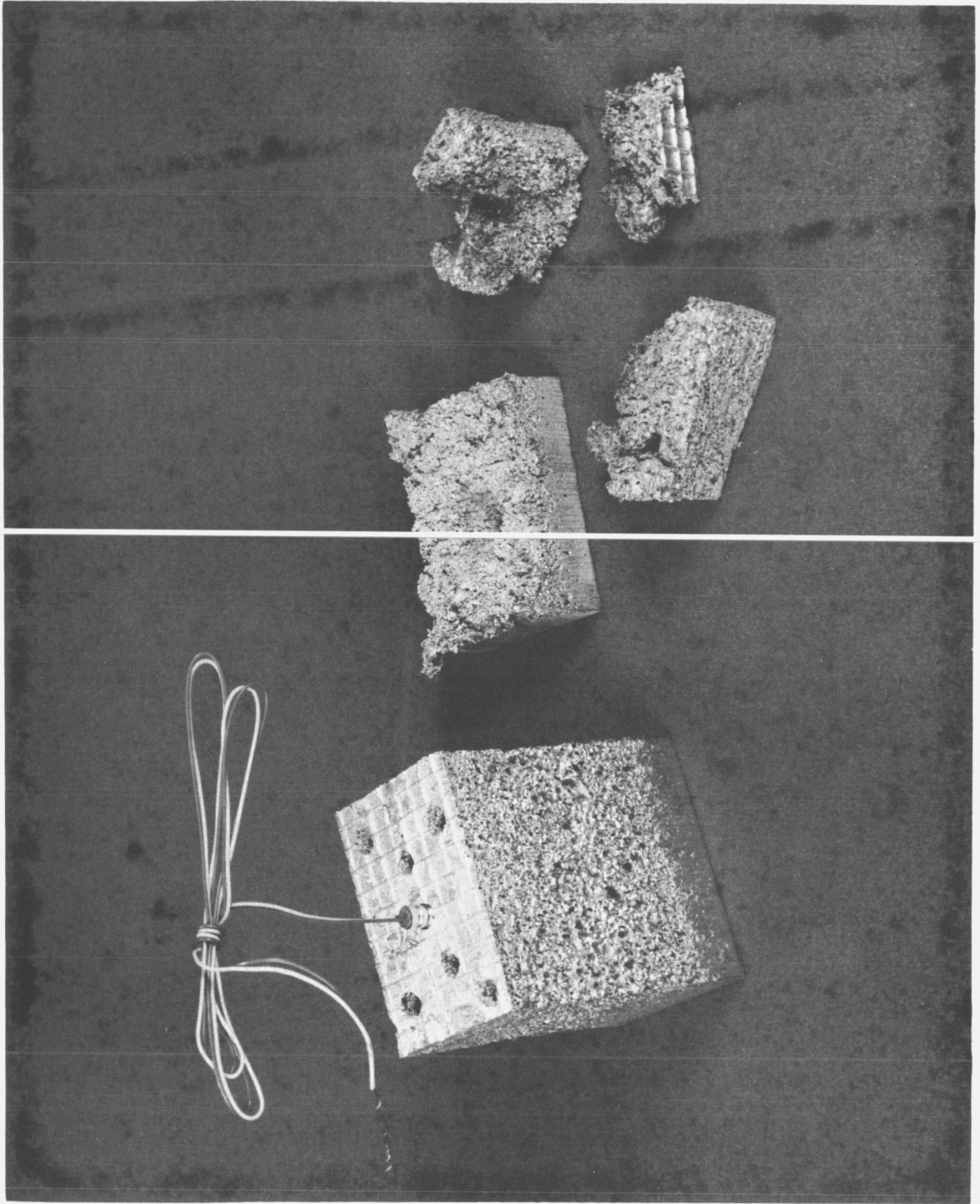

ig. 13 - Foam Aluminum Tested as Dunnage Material - Propagation Stop

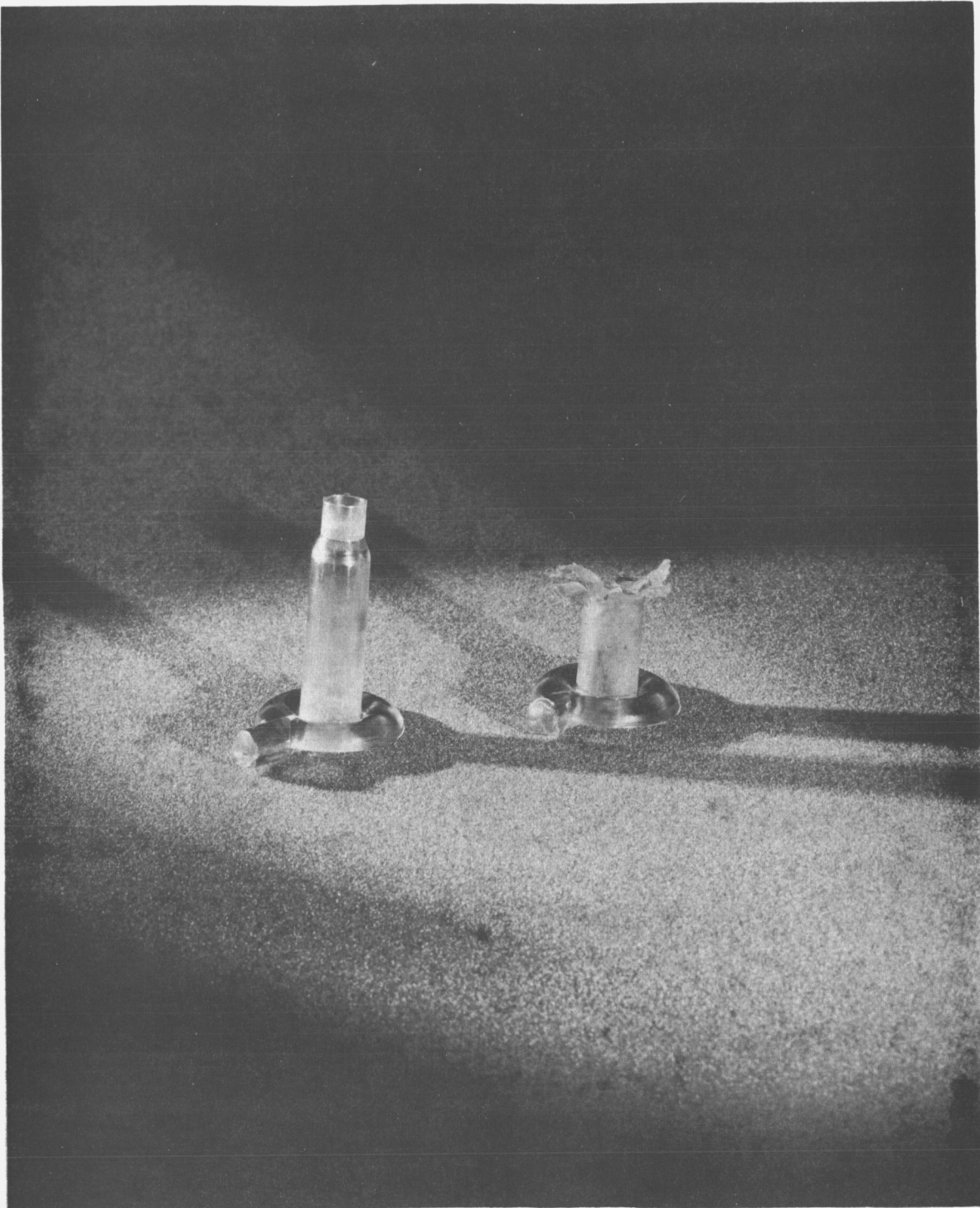

**Fig. 14 - Effects of T24E1 Detonator on Polycarbonate Plastics: Various Configurations**

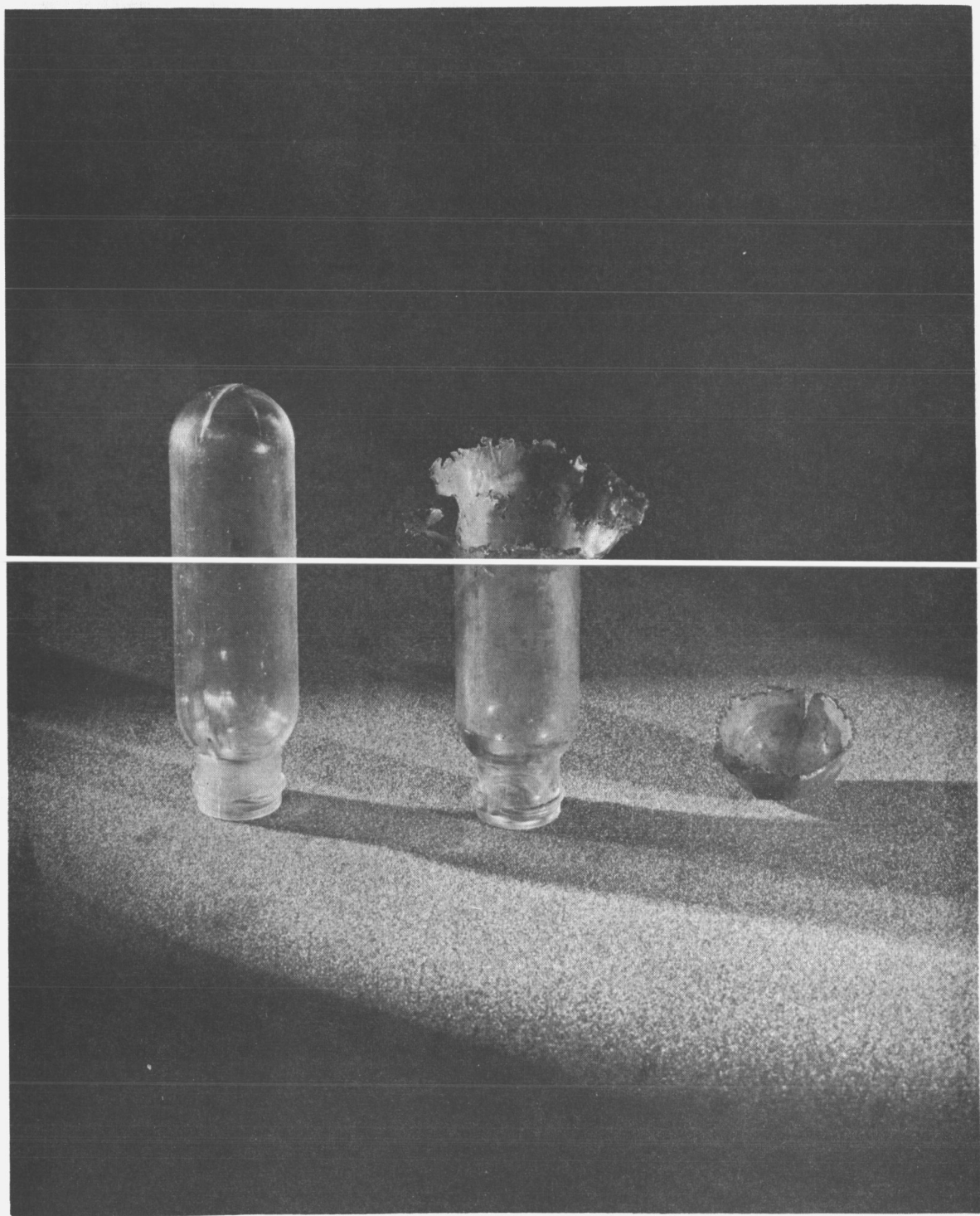

Fig. 15 - Effects of T24E1 Detonator on Polycarbonate Plastics: Various Configurations

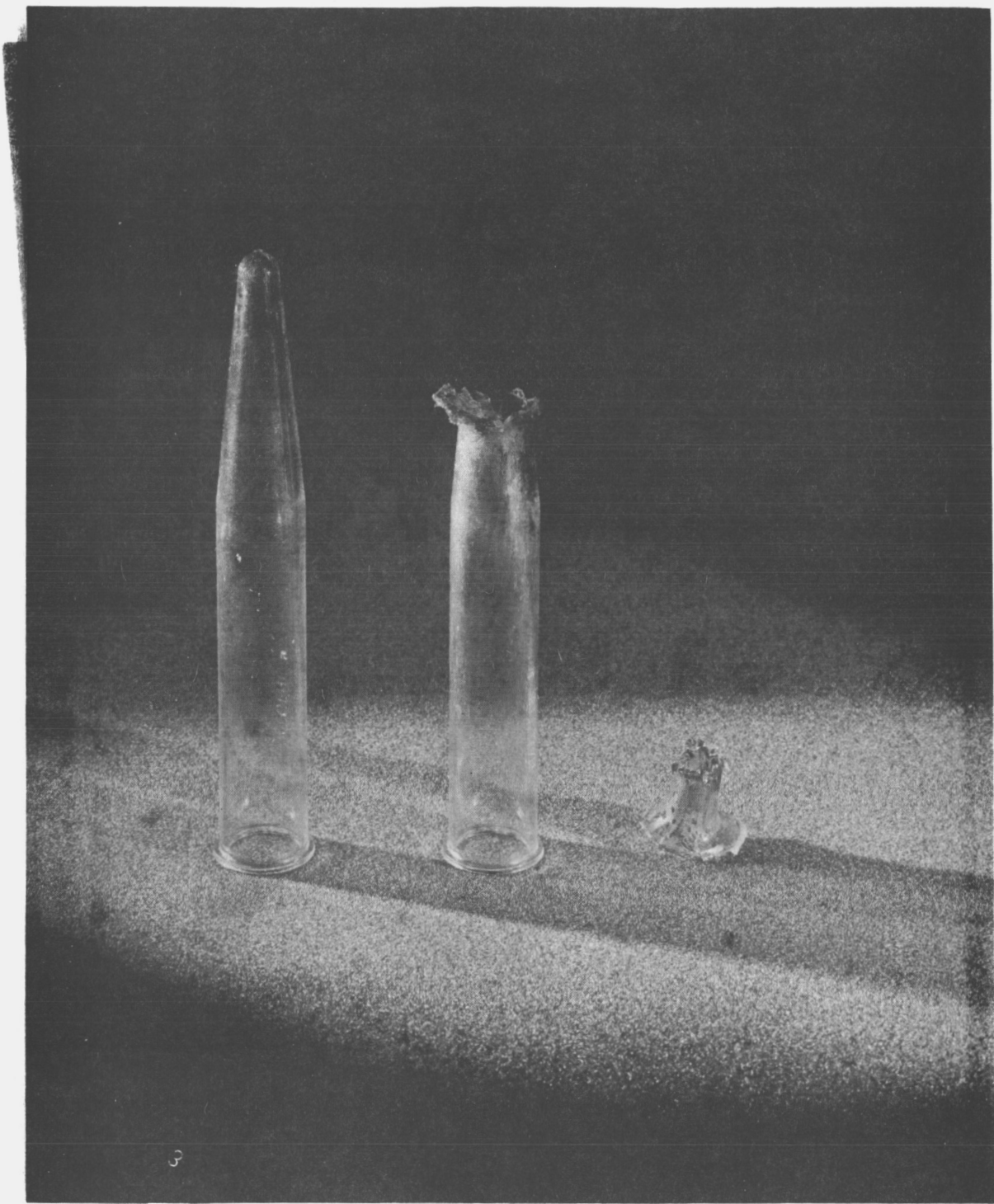

Fig. 16 - Effects of T24E1 Detonator on Polycarbonate Plastics: Various Configurations

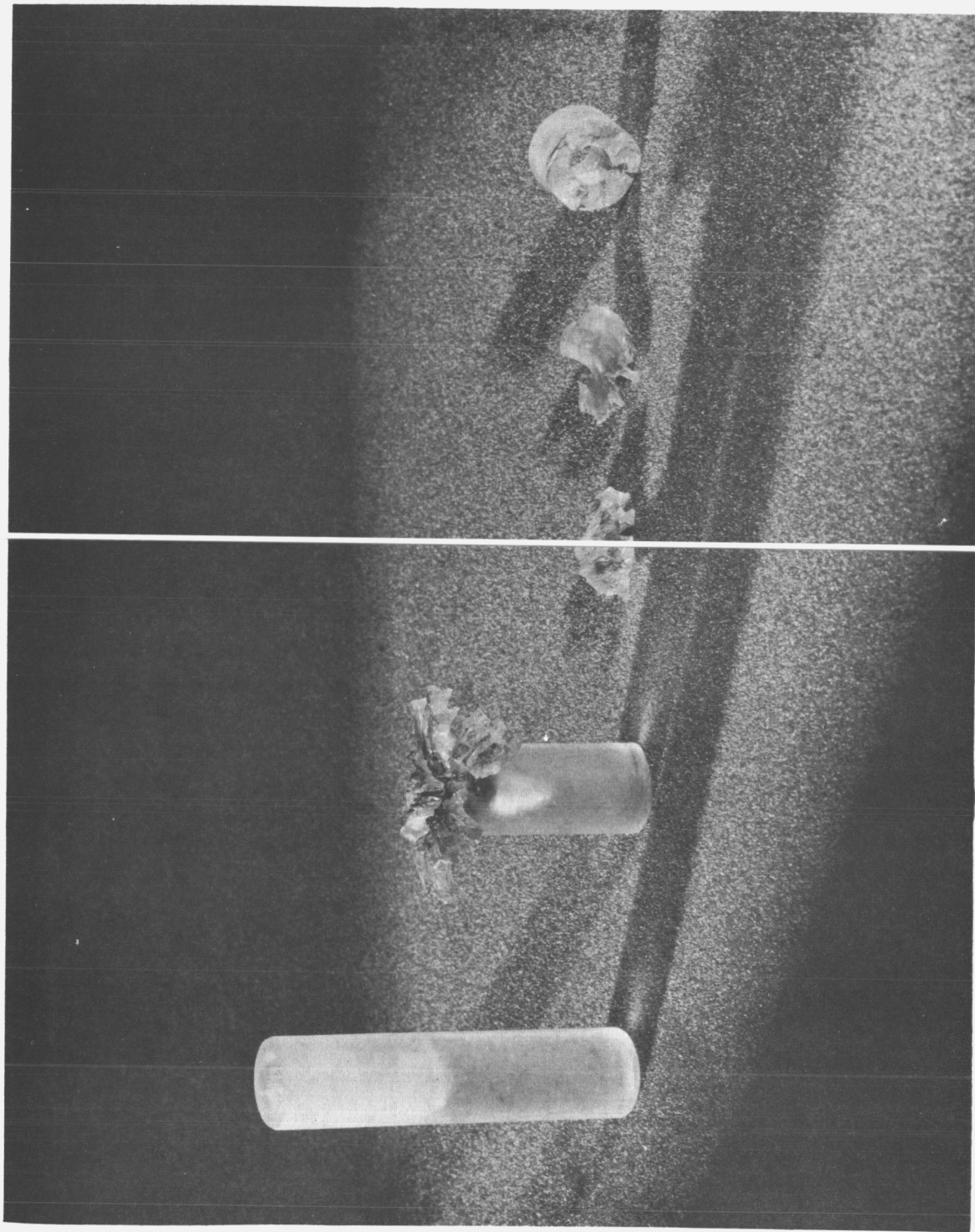

Fig. 17 - Effects of T24E1 Detonator on Polycarbonate Plastics: Various Configurations

Table 7

DESCRIPTION OF POLYCARBONATE MATERIALS  
TESTED FOR FRAGMENT AND BLAST PROTECTION

<u>Figure Number</u>	<u>Description</u>
14	Injection Molded Merlon*
15	Blow Molded Lexan**
16	Injection Molded Lexon
17	Extruded Lexan

While each of these materials appear to be severely damaged, the type of failure in each case indicates that the material is a potential absorber.

While it appears that explosive devices may be packed at relatively high densities as the results of some of the propagation tests indicate, caution is urged in the use of these data due to the relatively small quantities that were tested. The number of dunnage materials tested was also very small. There is certainly inadequate information here for reliable use of these materials even under the stated conditions. There is a general need for this type of information, and perhaps a more basic approach to obtaining it could be investigated. For example, a number of different types of explosive materials could be preseed into cylindrical bodies and exposed to similar testing procedures. Repeated tests of this nature could establish minimum distances in different, selected dunnage materials. Knowledge of the properties of materials under shock loading would be helpful in selecting the most promising materials to test.

---

\*Merlon is a trade name of the Union Carbide Co.

\*\*Lexan is a trade name of the General Electric Co.

#### 4.5 Summary of Section

- (1) Heat is no problem if EEDs qualified to 160°F. Normal dunnage will provide some thermal protection even in higher temperatures if exposure time is short.
- (2) Spark discharges from static field around lightning storms is a potential hazard. Sparking between small metal objects during dynamics of lightning discharge is a serious problem.
- (3) The magnetic field that accompanies the main stroke can couple loops in EED leads with enough energy to fire them. More sensitivity information is needed on EEDs in 10 to 100 micro-second time range to assess the problems. Ground gradients are a hazard in handling - not so much with packaged EEDs.
- (4) Direct Strikes are a real hazard to EEDs, packaged or unpackaged. Cylindrical metal containers afford some protection in event of direct strike.
- (5) Static discharges are a frequent cause of accidents. The human body needs only 200 volts to be in the troublesome range and has been known to accumulate 20,000 volts. Use of non-conductive plastics in packaging is unsafe. Additives and fillers reduce the resistivity of plastic films. Methods of assessing these materials are discussed.
- (6) Radio frequencies are analysed by a worst-case approach that makes use of circuit conditions optimized for power to the EED. Aperture methods of analysis are reviewed briefly. RF is a problem in packaging and shipping mainly for frequencies in the L Band or higher. "Connector" type EEDs are relatively safe from RF. Worst Case Analysis of a hypothetical loop results in an aperture of 0.25 square meters but this is worst case. There are handling problems because of large worst case apertures that are a real hazard in some instances. Help is needed here.
- (7) Vibrations of 15 g at 300 to 900 Hz have resulted in EED firings. Experiments with normal dunnage during drop indicate little if any problem with g loads up to 100 at drop heights of 30 inches. Tests on propagation of blast from one EED to others in the same package show Vermiculite to provide good protection. Polycarbonates and foam a aluminum are potentially good blast absorbers.



## 5. DISCUSSION OF PACKAGING PROBLEMS AND POSSIBLE SOLUTIONS

### 5.1 Heat

For packaging and handling, there is little need to be concerned with heat problems, at least in the shipping cycle and storage cycle. Normal conditions would have little effect on the electric initiator. Combined heating and any of the other factors considered in this report could present other problems of which we are not currently aware, but existing transportation temperatures and storage temperatures are well below the level that could be considered either hazardous or conducive to reliability problems if units are qualified to 160°F.

### 5.2 Electrical

Electrical environments still appear to be among the greatest hazards that the EED must survive. The problems stems from lack of the ability to detect electrical phenomena without instruments. Static is probably the number one cause of electrical accidents with EEDs, followed closely by lightning and RF. Simple shielding can reduce the frequency of accidents and the probability of their occurrence.

Plastic materials that absorb water from the atmosphere appear to have little advantage over conventional plastic materials if only the resistivity of the materials is considered. Even when the water-absorbing plastics are compared with conventional plastics using them as the belt of a Van de Graaff generator there appears to be less than one order of magnitude difference in charge generation. Appendix D contains results of studies on these materials. Hindsight dictates that neither of these tests are really conclusive concerning the application of this family of materials to EED packages. Simple qualitative experiments with the water absorbers and cloth show that rubbing produces little if any charge on the water absorbing plastic material compared to untreated plastic films. More work is needed in this light, and experiments with EED circuits are recommended.

A wrap of aluminum foil would greatly reduce the effects of electric fields and reduce static and RF problems appreciably. Some of the problems associated with radial fields in the earth surrounding a lightning strike would also be reduced.

The low frequency radiation from the magnetic field surrounding a lightning strike is more difficult to cope with. Methods to protect EEDs from this field, however, generally provide protection from the other electrical influences and will result in survival under almost any circumstance barring a direct lightning strike. The need here is for a complete enclosure and probably one made of iron that is copper plated on the outside and inside. The copper plating will account for approximately 45 db of attenuation at 10 kc due to reflection, and the iron will account for about 4 db /mil at this same frequency<sup>(36)</sup>. Excluding the effects of leakage through the end caps or shields, attenuation in the hundreds of db can be obtained using such a design with relatively thin-walled vessels and the attenuation increases with increasing frequency. Sensitivity data on EEDs in the region from 10 to 100 microseconds would be helpful in analysis of problems related to protection from lightning.

This procedure is not an electrical cure-all. First these devices must be packed in such a container and requirements of the ICC are that such containers be provided with dunnage between the device and the metal container. This dunnage must be reasonably static-free; there is no material that is completely static proof. The dunnage material needs more examination, but at this point, it would appear that resistance should be in the range of  $10^4$  ohms per square for surface resistivity or  $10^3$  ohm-cm for volume resistivity or lower. In other words it would be well to have the material be a semiconductor rather than an insulator.

Once the initiator is inside the metal enclosure, then any available means of further protection can be used. The static production of the additional dunnage makes little difference as long as the device

is in a metal enclosure. Only when the devices are being unpacked is there a possible hazard and that one can be easily eliminated by the choice of proper procedure. Proper procedure would include removal of all of the metal enclosures from the dunnage. This would be followed by placing all of the metal enclosures on a grounded bench top of highly conductive material either of metal or other conductor. Operations should be carried out with personnel grounded. The handling area should be freed from RF fields either by shielding or by an adequate survey of the area followed by shut-down of possibly-hazardous sources during handling.

Current shipping requirements set down by the ICC<sup>(5)</sup> show little concern with electrical problems at this time; and this is understandable in light of the existing record: devices are not often fired in an unexplained fashion while being shipped. Part of this is due to low intensity environments. In the future, however, there may be some difficulties as the RF environments are becoming more intense and the use of EEDs increases. It is a matter of probabilities and these are rapidly increasing in favor of more power being delivered to EEDs even in the packaged state.

Delivery of the packaged EEDs to a NASA launch site almost insures exposure to RF sources of a higher level than they have received in the earlier part of the journey. However, extra precautions are usually in force in such areas and unpacking and handling procedures are followed similar to those outlined above.

To establish and insure what levels of RF, static and lightning can be endured is a rather difficult problem; but this problem is being attacked and solved in a number of ways by various installations with success. An even broader solution to some of the problems of an electrical nature is being taken in some instances. The following listing indicates some of the current attacks being made:

- (1) A conscious effort is being applied to the development of static insensitive EEDs.
- (2) Increased firing current and power is being required of EEDs.
- (3) RF attenuation is being built into some EEDs.
- (4) Efforts are being made to use twisted shielded pairs in the design of circuits.
- (5) Worst-case analysis is being applied to circuits and the sensitivity of EEDs is being determined under RF excitation.

These developments are contributing to a reduction in electrical hazards. However there are not as yet any recognized standards which may be applied to packaging.

This study has not resulted in recommendations for crash programs to improve the design of EED packaging; however, there is some cause for concern. Some EEDs are getting through the network of testing that may cause problems from RF and from static as well as from lightning. These are the ones that could conceivably cause both safety hazards and possibly reliability problems.

More electrical testing is recommended for electric initiators that will tend to screen out devices that are ultra sensitive to static and RF. The form of this testing requires more study than the scope of this contract will permit. With this in mind, we have prepared a list of recommended packaging procedures that includes some pretesting of the electrical properties of the EEDs (Appendix C). This is intended as a guide for packaging and not as a universal test program. However, some of the recommendations may help in the general areas of safety and reliability.

### 5.3 Mechanical

It appears that current EED packaging practices protect from mechanical forces and heat with one major exception in as far as ICC regulations are concerned. Many of the devices that do not have a dangerous

output have no dunnage requirements. Unless the manufacturer of the EED knows better, there is no requirement that the devices be well protected from shock and vibration. However, it appears that the manufacturers and possibly his customer have in most cases worked out mutually satisfactory procedures.

There is clearly a large difference in the ability of dunnage materials to prevent propagation from one device to another in a package. Materials like vermiculite appear to have desirable isolation properties from blast and fragments. This material is also fire resistant, which makes an excellent combination of properties.

Polycarbonate plastics appear to offer high resistance to the effects of explosive output. While these materials may have some undesirable static electricity generating characteristics, other means of protection that are discussed in this report would make them ideally suited for barriers in EED package design. The use of these materials should be investigated further provided suitable means of reducing their electrical resistance can be found.

#### 5.4 Indicators for Monitoring Shipments

One means of assuring that a package has not been subject to extremes of environment in shipping, handling and storage is to include in the package some form of peak level indicator. Relatively inexpensive devices are now available that respond to humidity, temperature and acceleration. Those that are available include devices that change color due to humidity and temperature. The indicators for acceleration are a little more complicated and expensive, but these are resettable and may be used repeatedly. Most of the humidity indicators respond to the ambient condition and do not really indicate what has happened during the history of the system of which they are a part. Temperature indicators change permanently. Once they are subject to a temperature in excess of the value for which they are designed, there is a permanent change of

color, usually from white to black.\* The temperature range of these papers is from around 100 degrees F (37.8 C) to around 500 degrees F (260 C). Response time is on the order of 1 second at the temperature indicated. These devices are affected to some degree by humidity and also by solvents, greases, oil and water. Accuracy of temperature indication is on the order of 1%.

Humidity indicators change color. Under dry conditions the color is usually blue and when moisture is present the color changes to pink. Some of these indicators\*\* are graded in that the color change may occur in more than one area of the indicator. A device manufactured by the company cited has three circles about 1/2 inch in diameter marked 30, 40 and 50 that change progressively as the humidity increases. These are apparently made under a Mil-Std, for they are marked with MS20003-2.

Some devices for the sensing of acceleration operate by the retention of a mass by a permanent magnet.† The mass is of a magnetic material, so that it is attracted to the magnet. An accelerating force applied to the mass tends to release the mass from the magnetic attraction. If the accelerating force is large enough, the mass escapes the magnet's restraint and the indicator is tripped. Some of these devices are very directive and others operate over large angles of force. At times more than one indicator is used to sense the acceleration that an object receives because of the directive characteristics of the sensor. Mass-spring systems also exist for this purpose.††

---

\* These data are for the products manufactured by the Paper Thermometer Company, 10 Stagg Drive, Natick, Mass. 01762

\*\* From examination of a Humidity Indicator made by the Humidial Co., Colton, California

† The Inertia Switch Corporation manufactures devices like the ones described here.

†† Vexilar Engineering Inc., Box 738, Minneapolis, Minnesota 55440

While there are methods of determining the stimulus that an EED receives from electrical environments, none of these have been reduced to the point where they are acceptable universally. There is no simple and inexpensive sensor that will indicate that a device has received a certain ambient power density of RF radiation or a certain level of electric field. There is an active interest in this area and it appears that the development of an inexpensive sensor of this type would be welcomed. Current practice is to simulate the EED using an instrumented device that has about the same characteristics as the EED. Usually the bridgewire heating is detected or the potential that appears at the bridgewire (known as video detectors). It does not appear that this approach will be of help as an indicator in a package. "One shot" indicators would be of more value.

## 6. CONCLUSIONS AND RECOMMENDATIONS

### 6.1 Conclusions

- (1) Existing recognized regulations lack the detail necessary to design packages to guarantee safety and reliability in shipping and handling in the following areas:
  - (a) Electrical protection from static generated charge
  - (b) Electrical protection from radio frequency energy
  - (c) Electrical protection from lightning discharges
  - (d) Mechanical protection from drop and impact
- (2) Present shipping specifications offer reasonable safety of personnel and adjacent equipment during shipment but do not provide assurance of reliability at the destination.
- (3) Industry practices have solved a majority of current shipping problems without specification coverage. However it is to be anticipated that environments of the future will tend to become more severe than those to date particularly with regard to R.F.
- (4) Standardized sensitivity or sensitivity groupings of EED's offer one means of applying standard packaging practices.
- (5) Experimental data developed during this program show:
  - (a) Vermiculite to be one of the best dunnage materials to prevent propagation by blast and heat from detonating EEDs.
  - (b) Polycarbonate plastics to have failure mechanisms similar to metals during application of a detonator output.
  - (c) Water absorbing plastics to have resistivities differing only slightly from those of untreated plastics but tending less to accumulate charges.



- (d) Accidental drop of normally packaged EEDs from a height of 30 inches results in an acceleration of 90 g or less to the EED.
- (6) EEDs are safe from heat in normal shipping and storage conditions if they can withstand exposure to 160°F.
- (7) Data in the following areas are not considered adequate to draw conclusions:
  - (a) Electrical sensitivity of EEDs to pulsed energy in the time region of interest for lightning discharges (1 to 500 microseconds) is inadequate to pin-point hazard levels.
  - (b) Mechanical sensitivity of EEDs is not known accurately enough to preclude firing and loss of reliability due to physical damage.
  - (c) Properties of dunnage materials necessary to predict thickness requirements for flame, blast and shock isolation are not defined except by individual experiment or by judgment.
  - (d) Generalized static effects, other than those from human circuits, are not well enough defined in terms of the complete EED-circuit effect to predict results.
- (8) The design of EEDs and the materials used in them vary so widely that practical complete package design specifications are difficult to formulate. Performance specifications on both the package and the EED appear to be a reasonable possibility.

## 6.2 Recommendations

It is recommended that:

- (1) Performance specifications be generated for the packaging and shipping of EEDs including the features of Appendix C.
- (2) EEDs be completely wrapped in metal foil for shipping and storage for protection from static electricity, electric fields and high frequency RF until such time that more adequate protection is provided by specifications.
- (3) Further work be undertaken to design and prove a type of container for EEDs that will provide adequate electrical protection from low-frequency RF and the magnetic fields from lightning discharges as well as those of (2) above.
- (4) A more detailed study of dunnage materials be undertaken in order to obtain design information for specific classes of devices including detonating devices, igniting devices and pressure generating devices.
- (5) Indicators for packages be given further study to apply them in a quality assurance sense.
- (6) Further examination of water absorbing plastic films be undertaken with the objective of determining performance under operating conditions common to EED circuits.

These materials have potential applications where optically clear or translucent materials are needed (filled conductive plastics are opaque) or in clean rooms where some filled conductive plastics may cause contamination.

## BIBLIOGRAPHY

1. *Simulated Service Testing of Packaging*, ASTM Special Technical Publication No. 324, American Society for Testing and Materials, 1916 Race Street, Philadelphia, Pa. 19103
2. AFAL-TR-66-354, *Electromagnetic Hazards to Electroexplosive Subsystems*, North American Aviation, January, 1967 for Air Force Avionics Laboratory
3. Norman J. Bowman, and E. F. Knippenberg, *Pyrotechnic Devices for Use on Sterilized Spacecraft*, Journal of Spacecraft and Rockets Vol. 3, October 1966.
4. Gunther Cohn, *Survey of Explosives for Storage Stability and RF Protection*, The Franklin Institute Report F-B1843, July 1961
5. Agent T. C. George, *Interstate Commerce Commission Regulations*, Tariff No. 19. Issued by T. C. George, 63 Vesey Street, N. Y., August, 1966
6. M. G. Kelly and R. G. Amicone, *Study of Pretesting Effects on Electroexplosive Devices*, Franklin Institute Report F-1859, Currently in preparation.
7. L. D. Pitts, *Designing Electroexplosive Devices for Electrostatic Insensitivity*, General Precision Inc., Presented at 5th Electric Initiator Symposium, Franklin Institute, Proceedings Currently Being Published.
8. *Explosive Trains*, Engineering Design Handbook, Explosive Series, Army Material Command Pamphlet AMCP 706-179, March 1965
9. R. G. Amicone and P. F. Mohrbach, *Study of Design Parameters of Explosive Initiators with Respect to Space Environments*, Franklin Institute Report F-B2333, December 1965
10. W. Perkins and Allan Schlack, *High Temperature Resistant Electroexplosive Devices*, Frankford Arsenal, 5th Electric Initiator Symposium, Franklin Institute, Proceedings Currently Being Published.
11. *Electric Initiator Handbook (U)* (Third Edition) AD-318 980, Picatinny Arsenal and FIRL, Confidential, Nov. 1960
12. F. W. Brown, D. T. Kusler and F. C. Gibson, *Sensitivity of Explosives to Initiation by Electrostatic Discharges*, Report of Investigations 5002, Bureau of Mines, Sept. 1953.

13. P. W. Moore, J. F. Sumner and R. M. Wyatt, *The Electrostatic Spark Sensitiveness of Initiators, Part I - Introduction and The Study of Spark Characteristics*, Report No. 4/R/56, Explosives Research and Development Establishment, Waltham Abbey, Essex, United Kingdom, March 1956.
14. E. E. Hannum, *Current Testing Practice*, Franklin Institute Presentation in Proc. NASA Symposium on Electroexplosive Devices, Nov. 1966
15. N. P. Faunce, R. H. Thompson and R. F. Wood, *Investigation of the RF Hazards to Electric Blasting Caps*, The Franklin Institute Report F-B2256, August 1965.
16. AMCP 706-179, *Explosive Trains*, Engineering Design Handbook, Explosive Series, Headquarters, U. S. Army Material Command, March 1965, p. 33
17. I. S. Kurotori and H. Schafer, *Storage Temperature of Explosive Hazard Magazines, Part I American Desert*, Naval Ordnance Test Station Report NOTS TP 4143, Nov. 1966
18. Walter F. Friedman and Jerome J. Kipnees, *Industrial Packaging*, John Wiley and Sons, New York, N. Y. 1960, p. 40
19. Sir Basil Schonland, *The Flight of Thunderbolts*, Second Edition, Clarendon Press, Oxford, 1964
20. C. F. Wagner and G. D. McCann, *Induced Voltages on Transmission Lines*, AIEE Transactions, Volume 61, 1942
21. Sune Rusck, *Induced Lightning Over-Voltages on Power-Transmission Lines with Special Reference to the Over-Voltage Protection of Low-Voltage Networks*, Transactions of the Royal Institute of Technology, No. 120 Stockholm Sweden, 1958
22. R. G. Amicone, C. T. Davey and J. B. Campbell, *Electrostatic Hazard to Electroexplosive Devices from Personnel-Borne Charges*, FIRL Monograph 65-1, Feb. 1965.
23. *Static Electricity*, National Bureau of Standards Circular C438
24. *Data and Analytical Services Available from the Electromagnetic Compatibility Analysis Center (ECAC)*, Published by ECAC, U. S. Navy Marine Engineering Laboratory, Annapolis, Maryland 21402, May 1966
25. Same as 18, p.30

26. G. P. McCann and D. E. Morgan, *Field Disturbances Produced by Lightning*, AIEE Transactions, No. 62, 1943, p. 355
27. J. R. Stahmann, *Natural Interference Control Techniques*, Part III, Electromagnetic Transient Penetration of Aerospace Vehicle Systems, Technical Report ASD-TDR-63-370, 1964, AD-609 218
28. J. N. Ayres, *A Study of the Effects of Static Electricity on Low Input Energy Electric Initiators of the Carbon Bridge Type*, Electric Detonators, Proceedings of the Symposium, Franklin Institute, Sept. 1954
29. W. F. Bartoe, *Antistatic Agents*, Modern Plastics Encyclopedia, 1967.
30. Irving Litant, *Conductive Plastics*, EDN Magazine, 9 November 1966
31. N. P. Faunce, R. H. Thompson and R. F. Wood, *Investigation of the R.F. Hazards to Electric Blasting Caps*, Franklin Institute Research Laboratories Report, F-B2256, August 1965.
32. P. F. Mohrbach et al, *Hazards to EEDs at Wallops Station*, Franklin Institute Report I-C1846-1, January 1967
33. J. D. Kraus, *Antennas*, McGraw-Hill Book Co., New York, N. Y., 1950
34. O. B. Rawls, Stilwell and McDonald, *RF Radiation Hazards*, Air Force Missile Test Center Report AFMTC-TM-59-4, July 1959
35. C. T. Davey and George McKay, *Study of Vulnerability of M6 Blasting Cap in the Vicinity of HAWK Missile System Radars (U)*, Franklin Institute Report LM-A2357-10, August 1961
36. Rocco F. Ficchi, *Electrical Interference*, Hayden Book Co., New York, 1963.

REFERENCES (NOT CITED)

Kenneth Brown, *Package Design Engineering*, John Wiley and Sons, N. Y., N. Y. 1959

Louis C. Barail, *Packaging Engineering*, Reinhold Publishing Corporation New York, N. Y., 1954

Edward Beck, *Lightning Protection for Electric Systems*, McGraw-Hill Book Company Inc., New York, 1954

W. W. Lewis, *The Protection of Transmission Systems Against Lightning*, John Wiley and Sons, New York, 1950

A P P E N D I C E S

F-C1853



---

Appendix

APPENDIX A





## APPENDIX A

Approximation of Induced Potentials in Remote  
Loops Due to Lightning Discharges

In some respects the return stroke of a lightning discharge is much like a current through a wire. There are some differences in velocity and in the size of the channel carrying the lightning current as well as the length of the current channel as a function of time. Many points like this one are still in the stages of doubt and investigation. If we assume that the return stroke of a lightning discharge is like that of a current carrying conductor of infinite extent, then we can express the magnetic field surrounding the discharge as

$$B = \frac{\mu I}{2 \pi R} \quad (A-1)$$

where

- B = is the flux density (webers/square meter)
- $\mu$  = is the permeability of the medium (henries/meter)
- I = is the current in the conductor (amperes)
- R = is the radial distance from the stroke (meters)

Since the lightning stroke is a pulse of energy or current rather than a continuous current, the magnetic field around the stroke will vary with the current and at the same rate that the current varies.

It is known that when a closed conducting loop is exposed to a fluctuating magnetic field, an EMF is induced in the loop that may be expressed by\*

$$v = \frac{-d \int_s \vec{B} \cdot d\vec{s}}{dt} \quad (A-2)$$

\* John D. Kraus, *Electromagnetics*, McGraw Hill Book Co., N.Y., 1953.

where  $B$  = is the flux density (webers/square meter)  
 $s$  = is the elemental surface (square meters)  
 $v$  = is the induced EMF (volts)  
 $t$  = is the time (seconds)

At places where  $B$  is uniform over the surface being considered this equation may be reduced to

$$v = \frac{dB}{dt} A \sin \theta \quad (A-3)$$

where  $A$  = is the area of the loop (square meters)  
 $\theta$  = is the angle between the plane of the loop  
and the direction of the magnetic field (degrees)

The magnitude of the current that may exist in a lightning stroke is argumentative and definitely variable over large limits. Some observers claim that stroke currents in the return stroke could reach 150,000 amperes and it is generally agreed that the average stroke current is on the order of 30,000 amperes.

In safety considerations we must use the maximum current that is conceivable for other than probabilistic computations. Thus from equation (A-1) we can compute the magnitude of the flux density as a function of the distance from the point of a lightning stroke.

In order to use equation (A-3) to determine the magnitude of the voltage that will be induced in a loop of area  $A$ , we must know the rate at which  $B$  changes with respect to time. A number of experimenters have studied the problem of the wave shape of the pulse that lightning will produce. The electric field in the vertical direction due to the return stroke has been found to rise to a maximum value from zero in about 10 microseconds and to return to zero in about the same time.\* There are secondary effects that persist for longer periods of time, but this pulse appears to be the greatest part of the waveform.

\* K.M.L. Srivastava and B.A.P. Tantry, *VLF Characteristics of EMR from the Return Stroke of Lightning Discharge*, Indian J. of Pure Appl. Phys. Vol. 4, July 1966.

Equation (1), when solved with  $\mu = 1.257 \times 10^{-6}$  henry/meter gives,

$$B = \frac{2I 10^{-7}}{R} \quad (A-4)$$

With current rise and fall characteristics and the flux density defined by Figure A-1 the induced voltage in a loop will follow the shape also shown in this figure. The maximum EMF in a loop will be given by

$$v = \frac{\Delta B}{\Delta T} \frac{2I 10^{-7}}{R} A \cos \theta \quad (A-5)$$

The induced EMF for various distances and loop areas has been computed using this equation with a maximum current of 150,000 amperes. These data are plotted in Figure A-2.

There are errors in this approximation that would be best brought forward at this time. The assumption that the conductor is infinitely long introduces an error because we know that the maximum length that can be achieved is about twice the cloud height or on the order of 10,000 meters. Thus at distances that are not short with respect to 10,000 meters there will be an error that will result in an induced EMF of less than that indicated in Figure A-2. Another source of error is in the assumption that the current is continuous which also has a bearing on the length of the column. The current proceeds from ground to the cloud at finite velocity. At time zero, the velocity is zero and consequently the column height is zero. The velocity of the charge column increases to near that of light and then decreases. This phenomenon has the effect of a reduced column height which is particularly effective in reducing the computed induced voltage, particularly at great distance from the stroke. We feel that the use of the information presented will provide safe limits in the selection of shielding material and in the reduction of loop area to reasonable limits on the part of the designer.

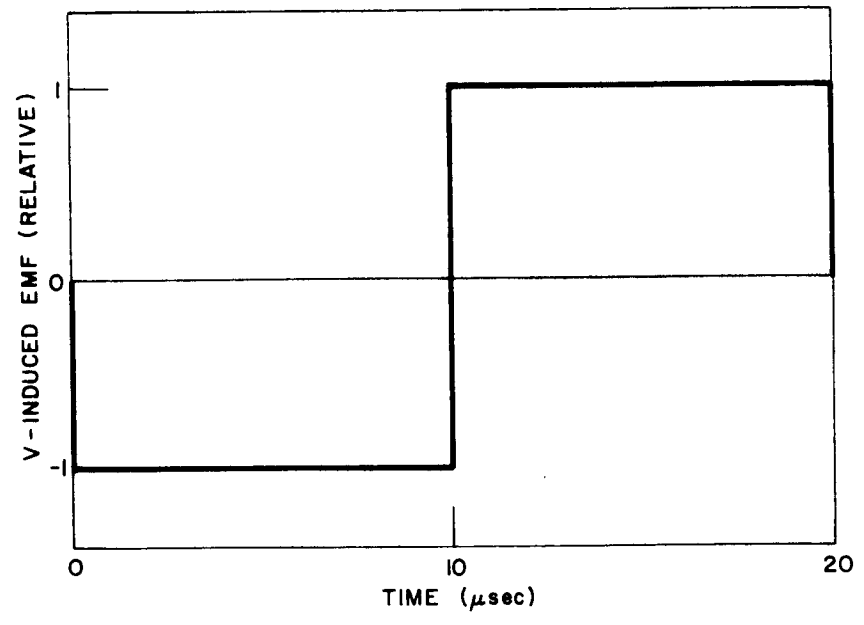
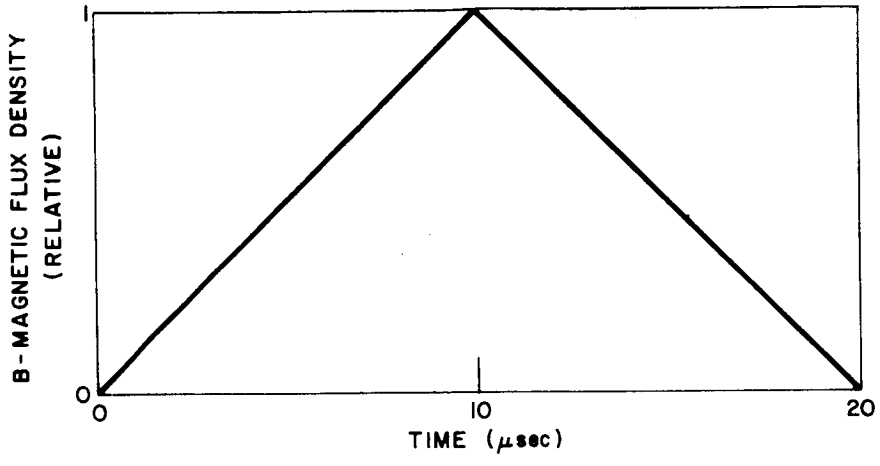

Fig. A-1 - Assumed Shape of Magnetic Field from Lightning Discharge and Resultant EMF Induced in Loop

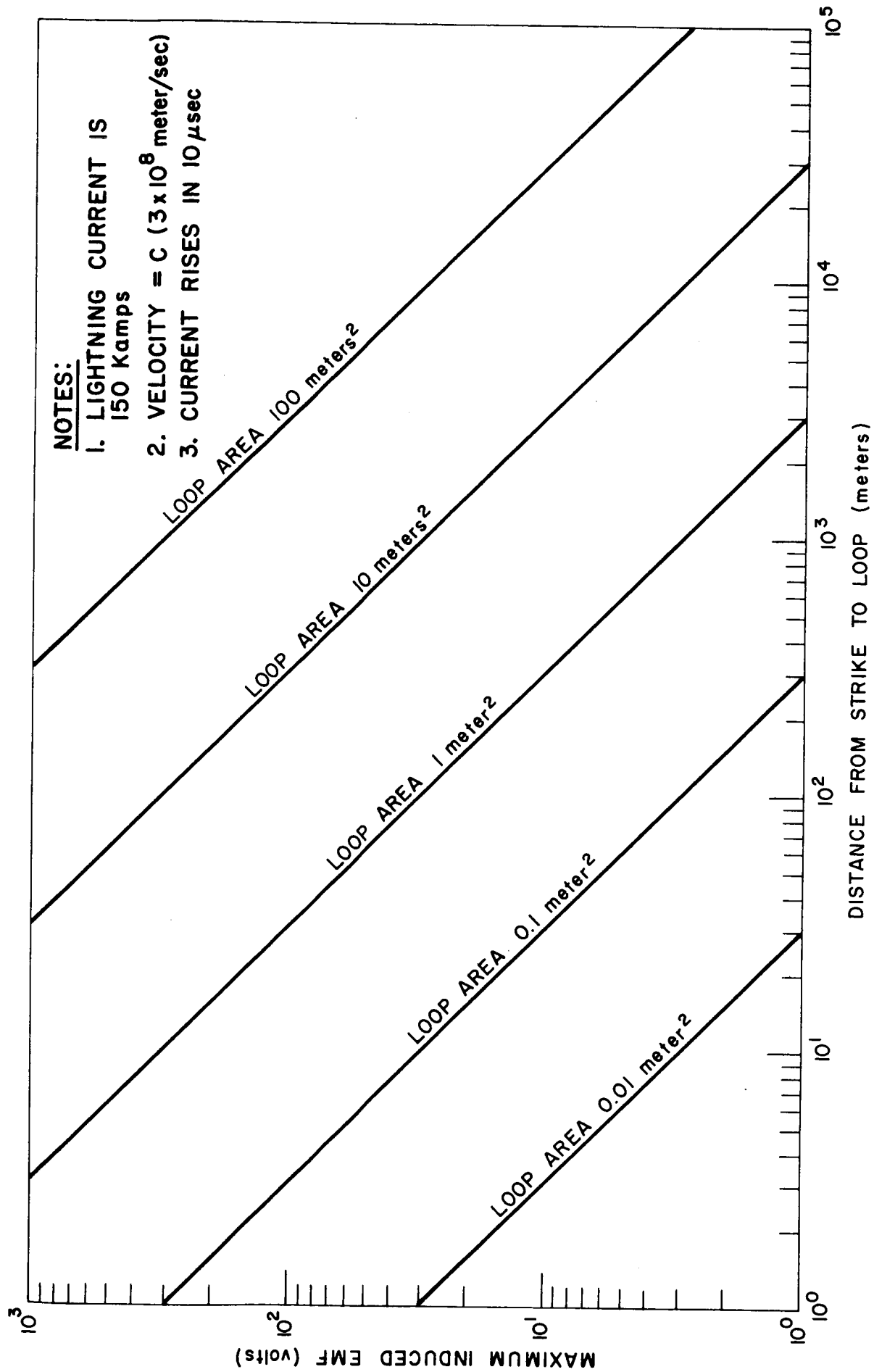
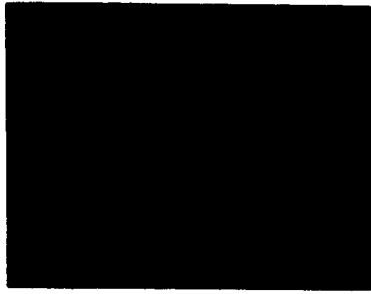

Fig. A-2 - Estimated Maximum Potentials Induced in Loops by Lightning Discharges



F-C1853

Appendix

APPENDIX B



## APPENDIX B

Summary of Shipping Regulations for  
Small Electroexplosive Devices

Shipping regulations for dangerous materials are governed by the Interstate Commerce Commission. These regulations for Highway, Rail and Water transportation are put forth in T. C. Georges' Tariff No. 19. This summary of regulations is intended only to serve as a guide and is not to be construed as legally authoritative.

## 1. Blasting Caps, Electric

These devices in Class A, maximum hazard by definition; but with one of two possible approaches, they may be identified as Class C, minimum hazard.

## 1.1 Normal Procedure for Class C Identity of Electric Blasting Caps

1.1.1 Quantity

- a. Not more than 1000 devices
- b. Not more than 50 grains (3.24 grams) explosive each
- c. Not more than 100 caps per inside package.

1.1.2 Outside Package

- a. Must meet Specifications 14 and 15A of Tariff. Sections 78.165 and 78.168 of Tariff No. 19 give Construction detail. Such as lumber nails, fasteners, joints and marking.
- b. Must be clearly labeled with contents stated.

1.2 Electric Blasting Caps - Class C under Laboratory Sample Provision  
Section 73.86 of Tariff No. 191.2.1 Quantity

- a. Not more than 100 caps in one outside package.

- b. Not more than 1/2 lb. per inside package and not more than 20 half pound samples per outside package.

1.2.2 Inside Package

- a. Metal cans, glass bottles, rubber containers or plastic that is not static generating. Strong waterproof paper or cardboard.

1.2.3. Cushioning

- a. Inside metal container must be surrounded with sawdust or similar cushioning material and packed in another wooden box prior to outside crating.

1.2.4. Outside Container

- a. Essentially same as 1.1.2

2. Igniter, Safety Squibs, Delay Electric Igniters and Electric Squibs - Class C - Section 73.106

These devices are to be packed in strong fiberboard or wooden boxes or metal barrels or drums properly described and properly marked with the name on the outside package.

3. Cable Cutters, Power Cartridges, Release Devices, Jet Starter Cartridges

These devices to be packed in Spec 12H, 23F, or 23M fiberboard boxes, gross weight not to exceed 65 lbs. Also may be shipped in strong wooden or metal boxes or otherwise containers approved by the Bureau of Explosives. Starter Cartridges are to have leads short circuited when shipped.

Must be marked with the name of the article and "HANDLE CAREFULLY - KEEP FIRE AWAY."



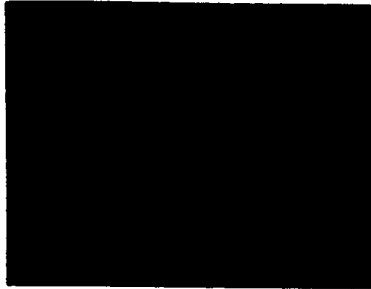

F-C1853

Appendix

APPENDIX C

1. Specifications on the Initiator
2. Packaging Requirements
3. Unpacking and Handling



## APPENDIX C

RECOMMENDED PROCEDURES FOR DEFINING INITIATOR  
SENSITIVITY, PROVIDING ADEQUATE PACKAGE PROTECTION,  
AND ASSURING SAFE HANDLING ENVIRONMENTS

## 1. Specifications on the Initiator

Specifications should be established that are compatible with the device being considered. Arbitrary sensitivity limits are a hindrance to progress in serving the real purpose of EEDs and that is to do great quantities of work with little initiating impetus.

## 1.1 Electrical

## a. Normal Sensitivity

The sensitivity of the device should be determined according to the Bruceton Plan and regression equations should be determined for the 5% and 95% probabilities of firing for times extending from 10 microseconds through 5 minutes.

## b. Sensitivity to Static Electricity

An adequate sample of the devices should be tested with voltage applied from pins-to-case and from bridgewire to bridgewire. The source should be a capacitor of 500 picofarads with a resistance of 5000 ohms connected between the capacitor and the device under test (in series). For safe human handling of the device, it should withstand a potential of 25,000 volts initially applied to the capacitor without firing or being degraded. Degradation shall be defined as a radical change in sensitivity or in other electrical properties.

## c. Radio Frequency Sensitivity

The RF power required to fire the device should be measured for at least three frequencies; continuous wave tests should be made at one frequency in the L band, and pulsed tests should be made

in the S and X bands. Probing techniques using a minimum of EEDs are recommended for these tests. Results should be obtained in the bridgewire, bridgewire to bridgewire and pins-to-case modes.

d. Power Ground Fault or Lightning Fault

At least 500 volts should be applied between pins-to-case and where more than one bridge element or electrode is involved, also between this electrode and other electrodes not intended for firing the device. The power source for this test should be capable of delivering at least 100 milliamperes.

Results of these tests should be reported and contained in each shipment of initiators from that particular lot in standard format with which operating personnel of NASA are made familiar.

## 1.2 Mechanical

- a. Each type of initiator shall be demonstrated to be safe and operable after exposure to 50g of acceleration as produced from a source of frequencies up to 30 cps and by drop tests in a fixture that is determined to be adequate to provide accelerations of 1000g.
- b. All devices that are to be used, packaged, transported or handled should be inspected for integrity of the explosive charge (presently a requirement of the ICC).

## 1.3 Heat

- a. Each type of EED shall be tested so that the device is demonstrated to be safe and operable after exposure to temperatures of 165°F for a period of at least one month. Shorter times may be used with higher temperatures if the method used is demonstrated to be equivalent.

## 2. Packaging Requirements

ICC regulations must be followed and in addition, the following are recommended.

### 2.1 Electrical

- a. Each device now shipped or stored should be wrapped in a complete enclosure of metal foil. This should be an interim measure until such time that suitable enclosures can be designed to provide attenuation at the lower frequencies and for the magnetic fields produced by lightning and by low-frequency radio transmission (see text).
- b. Design criteria for the metal enclosure should be based on the sensitivity information on the devices that are to be shipped. It may be that one design will take care of all situations. The basis for design should be the environment and sensitivity.
- c. Electrical requirements for dunnage that is to be fitted between the EED and the metal case should be that the material be conductive to the extent that no static hazard exists. It appears that the material should have a resistivity of  $10^4$  ohm-cm or less, but more work is considered necessary on the dynamic characteristics of anti-static plastics with conventional resistivities of  $10^{12}$  ohms (Appendix D).

### 2.2 Mechanical

- a. Adequate dunnage shall be applied to all packages to limit the acceleration of the EED to 50g under the conditions of frequency and drop impact acceleration contained in 1.2a.

## 3. Unpacking and Handling

### 3.1 Unpacking and Handling Environment

Assurance should be required that the area in which EEDs are to

be unpacked and handled are free from electromagnetic energy that could fire the device. This may be accomplished by survey of the electromagnetic radiation producers in the area and computing the ambient power density or by measuring this density and providing adequate shielding if necessary. Worst case analysis of possible antenna configurations should be made. Comparison of the antenna apertures and the ambient power density will determine either that the area is safe or that additional measures need to be taken to assure safe operations from RF.

All personnel handling EEDs should be grounded, preferably by wristlets. Floors, benches, table tops and other furniture in the area should be grounded to a common ground and if possible to a grounding grid system. Static producers should be rendered inactive by elimination of them from the area or by other suitable means.

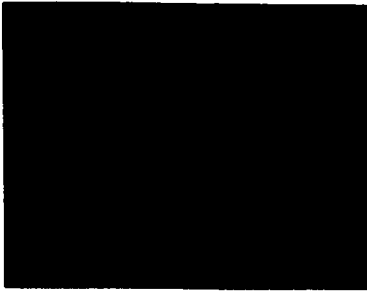

F-C1853

Appendix

APPENDIX D



## APPENDIX D

### Evaluation of Conductive Plastic Materials For Use in Initiator Packaging

Recent developments in plastics has led to the addition of materials to the mix prior to the molding of plastics that renders them more conductive to electrostatic charges. We were assigned the task of evaluating some of these materials for possible use in the packaging and handling of electric initiators.

In order to evaluate these materials we followed three plans of evaluation that take into the account the generation and dissipation of charge. Results of these evaluations are aimed at determining what effects these materials may have on electroexplosive devices.

The materials that were involved in this study consisted of the following:

1. Nylon - RC AS-2400, Fluorescent Orange Film
2. Polyethylene - RC AS-1200, Pink Film,  
both products of the Richmond Corporation, 27427 Pacific  
Avenue, Highland, California, 92346.
3. A commercial grade of Polyethylene film

The first test that was made involved the use of a small Van de Graaff machine. Comparisons were made of the ability of the machine to generate a potential with three belt materials: the standard rubber belt provided with the machine, a belt made from the commercial polyethylene and a belt made of the anti static polyethylene.

No meter was available to measure the very high potential that was generated on the top of the Van de Graaff generator; and for this reason, a gap was adjusted from the top of the machine to a grounded point about one inch from the upper electrode so that a controlled discharge

would occur at a relatively fixed potential and at a rate that is approximately proportional to the ability of the belt material to generate charge. All three of the materials produced enough potential on the large sphere of the Van de Graaff machine to produce sparking across the gap. The rates of spark production were very different. The rubber materials generated sparks at the highest rate, about 110 per minute. The ordinary polyethylene produced sparks at the rate of about 20 per minute and the second material listed above produced about 5 to 6 per minute. The rates appeared to be sensitive to atmospheric humidity.

Two types of tests involving resistance were made. The first of these is illustrated in Figure D-1. This method of evaluation is normally considered a measure of surface resistivity. A capacitor of 500 picofarads was placed across the two aluminum blocks along with a Sensitive Research electrostatic voltmeter. The time of decay of the potential was measured as a means of determining the surface resistivity of the conductive plastic sample. 500 picofarads was chosen because it is representative of the capacitance of the human being.

A second test was made by effectively using the sample as the dielectric of a capacitor. The sample was placed on a large metal ground plate and a 3 x 5 inch metal block was placed on top of the sample. Once more a 500 picofarad capacitor was placed in parallel with the sample and an electrostatic voltmeter placed in parallel with the sample and the capacitor.

Results of these tests are indicated in Table D-1. Plots of the time of discharge of the capacitor to 37% of the initial potential are shown in Figure D-2.

Bulk properties of the conductive plastics appear to change rapidly with ambient relative humidity and at relatively low potentials. The conductive nylon is two decades below the commercial polyethylene in time to discharge to 37% of the initial potential. The AS polyethylene is only one decade removed from the commercial polyethylene.

When 5000 volts is used as the initial potential, it appears that



TABLE D-1  
DISCHARGE MEASUREMENTS ON CONDUCTIVE PLASTIC MATERIALS

Test Humidity	Nylon RC-AS-2400		Polyethylene RC-AS-1200		Polyethylene Commercial	
	Time (sec)	Resistance (ohms)	Time (sec)	Resistance (ohms)	Time (sec)	Resistance (ohms)
$E_0 = 140$ volts						
Surface						
80%	68	$1.37 \times 10^{11}$	31	$6 \times 10^{10}$	88	$1.62 \times 10^{11}$
Bulk						
80%	1.6	$3.13 \times 10^9$	54	$10.6 \times 10^{10}$	171	$3.4 \times 10^{11}$
72%	11	$2 \times 10^{10}$	1440	$2.74 \times 10^{12}$	5460	$1.03 \times 10^{13}$
55%	44	$8.7 \times 10^{10}$	5400	$1.07 \times 10^{13}$	Not Measured	
$E_0 = 5000$ volts						
Surface						
45%	825	$1.62 \times 10^{12}$	+3600*	$+5.4 \times 10^{12}$ *	3600*	$5.4 \times 10^{12}$ *
20%	1510	$2.9 \times 10^{12}$	1960	$3.88 \times 10^{12}$	2280	$4.5 \times 10^{12}$
Bulk						
45%	†		548	$1.1 \times 10^{12}$	3600*	$5.4 \times 10^{12}$ *
20%	†		590	$1.16 \times 10^{12}$	3600*	$5.4 \times 10^{12}$ *

\* The reading was in excess of this time and probably much longer in duration or larger in resistance than is indicated.

† The material discharged immediately and could not build up to the potential of the source.

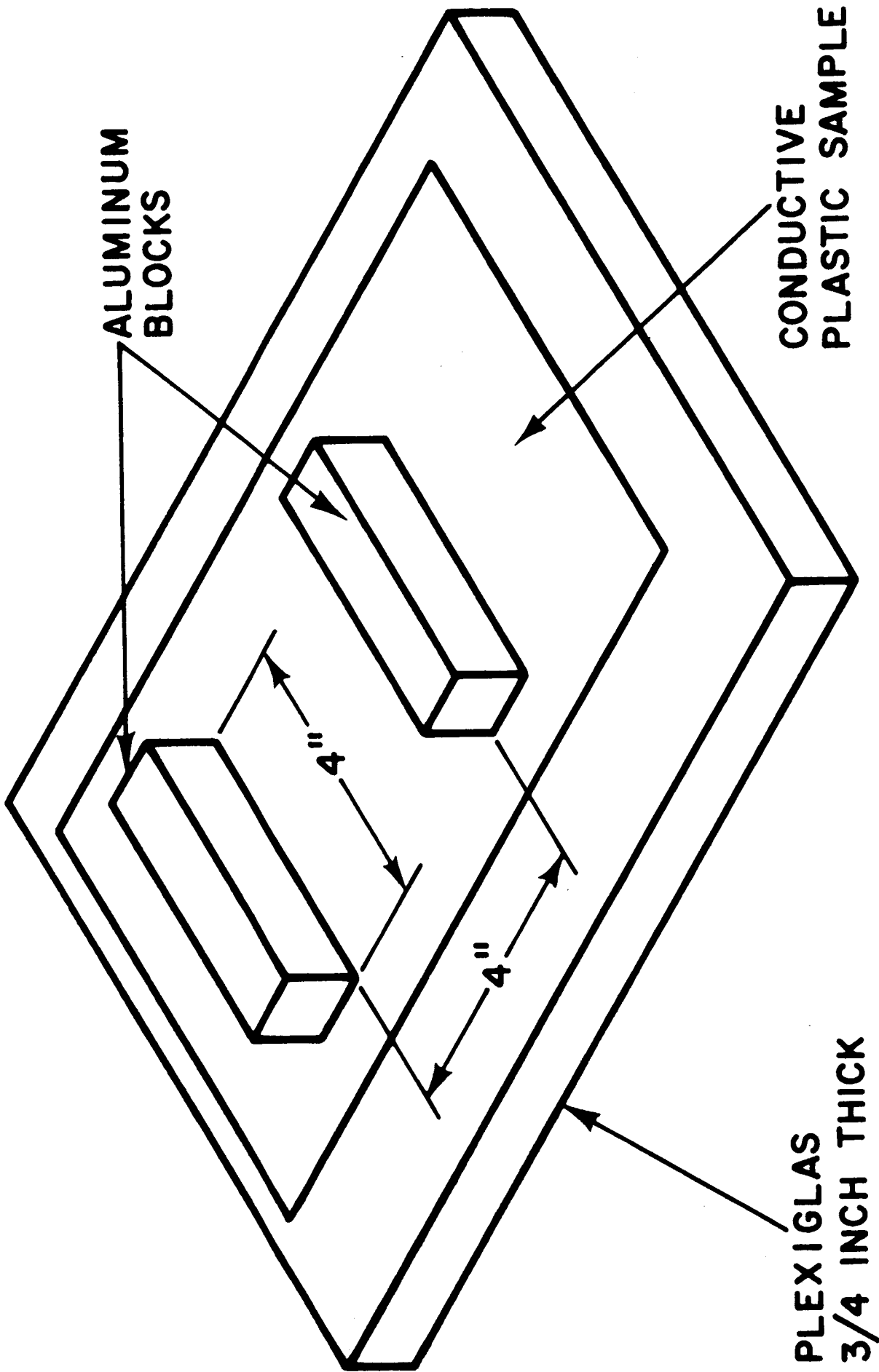

Fig. D-1 - Method of Measuring Surface Resistance of Conductive, Anti-Static Plastic Films

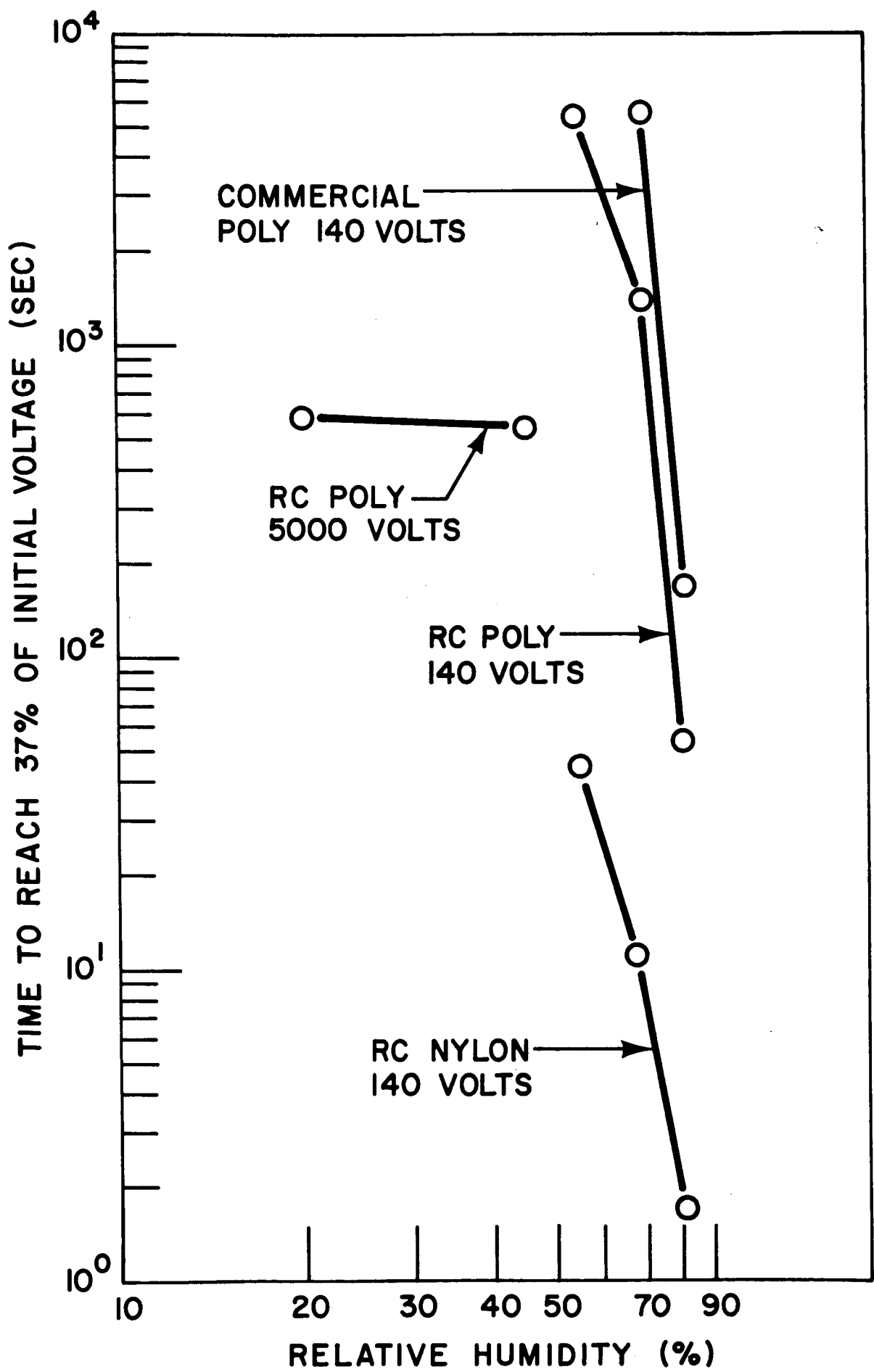

Fig. D-2 - Bulk Properties of Anti-Static Plastic Materials

relative humidity has a lesser effect. This is illustrated by the relatively flat line in Figure D-2. The RC AS-2400 would not accept a charge when it was used as the dielectric of a capacitor (bulk properties). It immediately discharged the source to a potential below 100 volts that was not readable on the voltmeter.

Surface resistivity appears to be fairly uniform for all of the materials tested including the commercial polyethylene. Part of this involves the instrumentation that was used to evaluate the surface resistivity. It is believed that there was considerable leakage in shunt with the measuring and discharge system and that this made differences in the properties of the materials difficult to measure. Differences did show themselves at the lower voltage as is evidenced by the first row of resistance readings of Table D-1.

The results of these tests do not show large differences between the conductive or antistatic materials. It appears that more is involved in the action of these materials than is evident from the usual electrical measurements. It has not been possible to build up a charge on the antistatic materials by the conventional rubbing processes in comparison to the commercial grades of polyethylene. Additional measurements and additional studies are required on these types of materials in general.

Since they do not appear to generate a static charge when used in the normal handling methods, they appear to be better for use with explosive devices than conventional untreated plastic materials.

DISTRIBUTION LIST

NASA,  
Washington, D.C. 20546  
Attn: RPM/William Cohen (5)  
ATSS-AC/Tech. Library (2)  
RPS/Robert Ziem (5)  
RP/A. O. Tischler

NASA, George C. Marshall Space  
Flight Center  
Redstone Arsenal  
Huntsville, Alabama 35812  
Attn: John Q. Miller  
Tech. Library

NASA, Manned Spacecraft Center  
Houston, Texas 77058  
Attn: Tech. Library  
J. G. Thibodaux

NASA, Lewis Research Center  
21000 Brookpark Road  
Cleveland, Ohio 44135  
Attn: Tech. Library

NASA, Goddard Spaceflight Center  
Greenbelt, Maryland 20771  
Attn: Tech. Library

Jet Propulsion Laboratory  
California Institute of  
Technology  
4800 Oak Grove Drive  
Pasadena, California 91103  
Attn: Tech. Library  
Winston Gin

Chemical Propulsion Information  
Agency  
Applied Physics Laboratory  
8621 Georgia Avenue  
Silver Spring, Maryland 20910

Commander, Army Ballistic Missile  
Agency  
Redstone Arsenal  
Huntsville, Alabama 35812  
Attn: ORDAB-HSI

Ballistic Research Laboratory  
Aberdeen Proving Ground  
Aberdeen, Maryland 21001  
Attn: Tech. Library

Director, Advanced Research Projects  
Agency  
The Pentagon, Room 3D 154  
Washington, D.C. 20301  
Attn: Tech. Information Office

Dept. of the Air Force  
Headquarters, USAF, DCS/D  
Washington, D.C. 20545  
Attn: AFDRT-AS

Air Force Systems Command  
Space Systems Division  
Air Force Unit Post Office  
Los Angeles, California 90045  
Attn: Col. H. Robbins

Department of the Army  
Office, Chief of Ordnance  
Washington D.C. 20545  
Attn: ORD TB

Picatinny Arsenal  
Dover, New Jersey 07801  
Attn: Tech. Library

a

Commander, Army Missile Command  
Redstone Arsenal  
Huntsville, Alabama 35809  
Attn: AMSMI-RKC  
Mr. Frank James, AMSMI-RK

NASA, Langley Research Center  
Langley Station  
Hampton, Virginia 23365  
Attn: R. L. Zavasky, Mail Stop 117  
Contracting Officer,  
Mail Stop 138  
Library, Mail Stop 185  
Richard F. Milliken,  
Mail Stop 498 (5)  
Robert L. Swain,  
Mail Stop 217  
Research Reports Division,  
Mail Stop 122

United Technology Center  
P.O. Box 358  
Sunnyvale, California 94088  
Attn: Librarian

Allegany Ballistics Laboratory  
Hercules, Inc.  
Cumberland, Maryland 21502  
Attn: Librarian

Lockheed Propulsion Company  
Redlands, California 92373  
Attn: Helen Ashman, Librarian

Rocketdyne,  
Division of North American  
Rockwell, Inc.  
Canoga Avenue  
Canoga Park, California 91303  
Attn: Librarian

Lockheed Missiles & Space Company  
P.O. Box 504  
Sunnyvale, California 94088  
Attn: Librarian

Aerojet General Corporation  
P.O. Box 1168  
Sacramento, California 94086  
Attn: R.G. Weitz, Head, Tech.  
Information Center

Thiokol Chemical Corporation  
Wasatch Division  
Brigham City, Utah 84302  
Attn: Librarian

Thiokol Chemical Corporation  
Huntsville Division  
Huntsville, Alabama 35801  
Attn: Librarian

Thiokol Chemical Corporation  
Longhorn Division  
Marshall, Texas 75670  
Attn: Librarian

Thiokol Chemical Corporation  
Elkton Division  
Elkton, Maryland 21921  
Attn: Librarian

Atlantic Research Corporation  
Shirley Highway at Edsall Road  
Alexandria, Virginia 22314  
Attn: Librarian

Atlantic Research Corporation  
Airport Imperial Building,  
Suite 700  
El Segundo, California 90245  
Attn: Librarian

Atlas Chemical Industries, Inc.  
Aerospace Components Division  
Valley Forge Industrial Park  
Valley Forge, Pennsylvania 19481  
Attn: Robert McGirr,  
Pyrotechnics Manager

Beckman Whitley, Inc.  
985 San Carlos Avenue  
San Carlos, California 94070  
Attn: Librarian

Bermite Powder Company  
2216 Canyon Road  
Saugus, California 91350  
Attn: Mr. J.H. Arnold, Vice  
President

b

Conax Corporation  
2300 Walden Avenue  
Buffalo, N.Y. 14225  
Attn: Librarian

DuPont deNemours & Company  
Chemical Products Division  
Pompton Lakes, N.J. 07442  
Attn: Librarian

Ensign-Bickford Company  
650 Hopmeadow Street  
Simsbury, Conn. 06070  
Attn: Librarian

Explosive Technology, Inc.  
P.O. Box KK  
Fairfield, California 94533  
Attn: Librarian

Hercules, Inc.  
Port Ewen, N.Y. 12466  
Attn: Librarian

Hi-Shear Corporation  
2600 W. 247th Street  
Torrance, California 90505  
Attn: Librarian

Holex, Inc.  
San Juan Road  
Hollister, California 95023  
Attn: Mr. E.J. Stecker, President

McCormick-Selph Associates  
Hollister Airport  
Hollister, California 95023  
Attn: Mr. Herbert Bennett,  
General Manager

Pyrofuse Corporation  
121 S. Columbus Avenue  
Mt. Vernon, N.Y. 10553  
Attn: Librarian

Pyronetics, Incorporated  
10025 Shoemaker Avenue  
SantaFe Springs, California 90670  
Attn: Librarian

Pyrodyne, Incorporated  
11876 Wilshire Boulevard  
Los Angeles, California 90025  
Attn: Librarian

Space Ordnance Systems  
133 Penn Street  
El Segundo, California 90246  
Attn: Librarian

Sandia Corporation  
Livermore, California 94550  
Attn: Librarian

Technical Products Company  
6670 Lexington Avenue  
Los Angeles, California 90038  
Attn: Librarian

Commander, Air Force Systems  
Command  
HQ 6593 Test Group (Development)  
Edwards Air Force Base,  
California 93523  
Attn: Mr. Don Hart (2)

Rocketdyne Division of North  
American Rockwell Inc.  
Solid Propellant Operations  
P.O. Box 548  
McGregor, Texas 76657  
Attn: Librarian

Universal Match Company  
Salinas Field Station  
P.O. Box 827  
Salinas, California 93901  
Attn: Librarian

HydroSpace Technology, Inc.  
Clinton Road & Rt. 46  
West Caldwell, N.J. 07006  
Attn: Librarian

Unidynamics, Phoenix Division  
P.O. Box 2990  
Phoenix, Arizona 85002  
Attn: Librarian

Ordnance Products  
No Street Address  
Northeast, Maryland 21901  
Attn: Librarian

Pelmec Division  
Quantic Industries, Incorporated  
1011 Commercial Street  
San Carlos, California 94070  
Attn: Librarian

Propellex Division  
P.O. Box 187  
Edwardville, Illinois 62025  
Attn: D.R. McGovern, Vice  
President Engineering

NASA, Ames Research Center  
Moffett Field, California 94035  
Attn: Library

NASA, Flight Research Center  
P.O. Box 273  
Edwards, California 93523  
Attn: Library

NASA, John F. Kennedy Space Center  
Kennedy Space Center, Florida 32899  
Attn: Library

NASA, Western Operations  
150 Pico Boulevard  
Santa Monica, California 90406  
Attn: Library

NASA, Wallops Station  
Wallops Island, Virginia 23337  
Attn: Library

NASA, Electronics Research Center  
575 Technology Square  
Cambridge, Massachusetts 02139  
Attn: Library

NASA, Michoud Assembly Facility  
P.O. Box 26078  
New Orleans, Louisiana 70126  
Attn: Library

NASA Scientific & Technical  
Information Facility  
P.O. Box 33  
College Park, Maryland 20740  
(14 plus repro.)