

GPO PRICE \$ _____

CSFTI PRICE(S) \$ _____



THE PENNSYLVANIA
STATE UNIVERSITY

Hard copy (HC) 3.00

Microfiche (MF) .65

ff 653 July 65

IONOSPHERIC RESEARCH

Scientific Report No. 316

A KINETIC THEORY BOUNDARY VALUE PROBLEM IN A FLOWING PLASMA: THE IMPEDANCE OF A GRID PAIR

by

D. P. Mioduszewski

March 1, 1968

The research reported in this document has been sponsored by the National Science Foundation under Grant GP-5611 and, in part, by the National Aeronautics and Space Administration under Grant 39-009-032.

IONOSPHERE RESEARCH LABORATORY

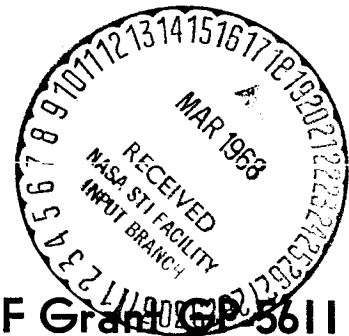
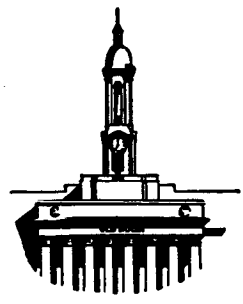

University Park, Pennsylvania

NSF Grant GP-5611

(ACCESSION NUMBER) _____
 (THRU) _____
 (PAGES) 103
 (CODE) _____
 (CATEGORY) _____
CR-93428
 (NASA CR OR TMX OR AD NUMBER)

FACILITY FORM 602

Ionospheric Research
NSF Grant GP-5611
Scientific Report

on

"A Kinetic Theory Boundary Value Problem in a
Flowing Plasma: The Impedance of a Grid Pair"

by

D. P. Mioduszewski

March 1, 1968

Scientific Report No. 316

"The research reported in this document has been sponsored by the National Science Foundation under Grant GP-5611 and, in part, by the National Aeronautics and Space Administration under Grant 39-009-032."

Submitted by:

B. R. F. Kendall

B. R. F. Kendall, Associate Professor of Physics

Approved by:

A. H. Waynick

A. H. Waynick, Professor of Electrical Engineering
and Director, Ionosphere Research Laboratory

Ionosphere Research Laboratory
The Pennsylvania State University
College of Engineering
Department of Electrical Engineering

TABLE OF CONTENTS

	Page
Abstract	i
I. INTRODUCTION	
General Statement of the Problem	1
Physical Problem	1
Electron Fluid Theory	4
Kinetic Theory (Landau-Vlasov Theory) of Plasmas	7
Boundary Value Problems.	14
Specific Statement of Theoretical Problem.	16
II. THEORETICAL METHOD	
Simple Physical Problem	17
Transforms and Causality.	21
Kinetic Theory Problem.	27
The Dispersion Function	31
Theorem I	35
General Form of the Solution	35
III. CALCULATIONS AND RESULTS	
Zero Order Distributions and Zeroes	42
Impedance of a Grid Pair in a Plasma	43
Significance of Parameters	48
Description of Graphs	50
IV. DISCUSSION	
Introduction	60
Discussion of the Graphs	60
Energetics	64
Limitation to the Applicability of the Theory.	67
Results Related to Those Obtained by Others.	70
V. SUMMARY AND CONCLUSIONS	
Statement of the Problem	73
Results and Conclusions.	75
Suggestions for Further Research	77
APPENDIX A Special Functions and Partial Fraction Expansion . .	79
Auxiliary Functions	79
Partial Expansion	81
APPENDIX B Methods of Computation	83

	Page
• APPENDIX C Landau's Problem	86
APPENDIX D Characteristic Zero	89
Theorem II	90
Theorem III	94
BIBLIOGRAPHY	98

ABSTRACT

This paper develops a technique for handling a class of plasma kinetic theory boundary value problems where plasma flows are taken account and then applying it to the problem of calculating the impedance of a grid pair through which a plasma is flowing perpendicularly to the grids.

The Fourier-Laplace Transforms are used to solve the problem after the inclusion of the boundary values into the differential equations.

Graphs of the impedance are obtained for various parameters. It is shown that the negative resistance, which Rydbeck showed could exist using the cold-electron fluid theory, is a drift phenomenon and does not exist for a stationary plasma. In addition, it is also shown that Debye shielding disappears when the drift velocity becomes much greater than the thermal velocity of the plasma and that Debye shielding is directly related to the fast wave of the cold electron fluid theory.

I. Introduction

General Statement of the Problem

This thesis deals with two related problems -- one, which will be called the physical problem; the other, which will be called the theoretical problem. The theoretical problem consists of finding a general mathematical method for the solution of a class of one dimensional kinetic theory plasma problems, especially those which take plasma flows into account. The physical problem, which consists of finding the impedance of a grid pair in a flowing plasma, is a particular situation to which the mathematical method may be applied and served as a motivation to develop the method. The specific statement of the physical problem will be made first. The specific statement of the theoretical problem will follow the discussion of the kinetic theory approach (Landau¹-Vlasov² theory) upon which it is based.

Physical Problem

Figures 1 and 2 give physical pictures of the system under consideration. Figure 1 shows an external circuit which drives the grid pair. There is a current flowing through this circuit which is $I_c e^{j\omega_0 t}$ where ω_0 is the driving frequency. The potential difference across the grids is $\Delta\phi$. If A_0 is the area of the grids, the current density fed into the plasma by the grids is $I_0 e^{j\omega_0 t}$ where $I_c = A_0 I_0$.

The impedance per unit area of the plasma and grids is therefore

$$Z_p(\omega_0) = \frac{\Delta\phi}{I_0 e^{j\omega_0 t}} \quad (1)$$

Figure 2 gives a picture of the hypothetical system to be considered in solving the problem. A critical discussion will be made in Chapter IV as to the applicability of the results based upon this hypothetical system to a realistic physical system. Two infinite grid planes are present in an infinite plasma with current density $I_0 e^{j\omega_0 t}$ flowing out of one grid at $x = -x_0$ and into the other at $x = x_0$. The entire plasma, electrons and ions, is assumed to move so as to have a zero-order or undisturbed electron velocity distribution with a fluid velocity of u_0 , which is perpendicular to the grids. In order to have the zero-order velocity distribution homogeneous in space -- that is, having no spatial gradients -- a strong magnetic field B_0 will be assumed to exist in the direction of the plasma flow.

The impedance of a mono-velocity (zero temperature) flowing plasma has been obtained by Rydbeck³, whose results will serve as an excellent check upon those presented in Chapter III. By using the Landau-Vlasov theory, the plasma impedance will be obtained in terms of the velocity spread of the zero-order distribution neglected by Rydbeck. Before

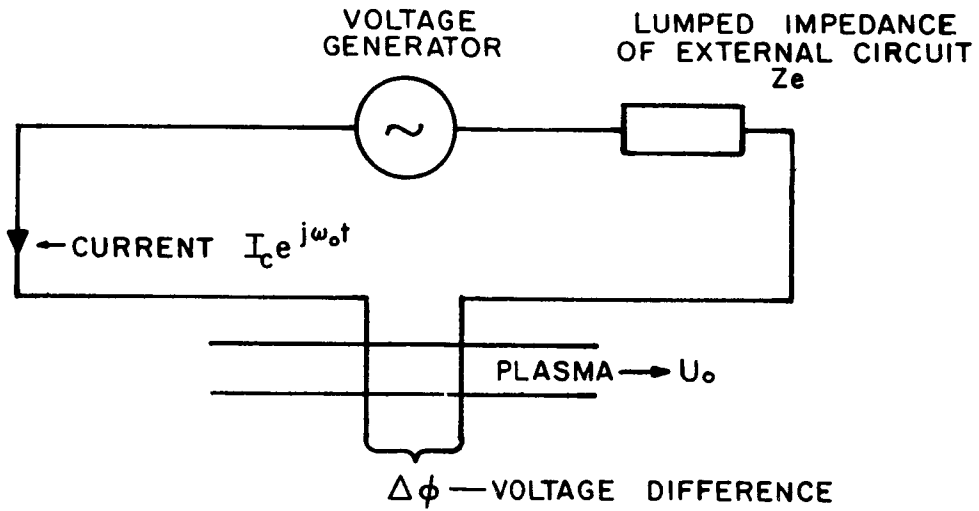

EXTERNAL DRIVING CIRCUIT

FIGURE 1

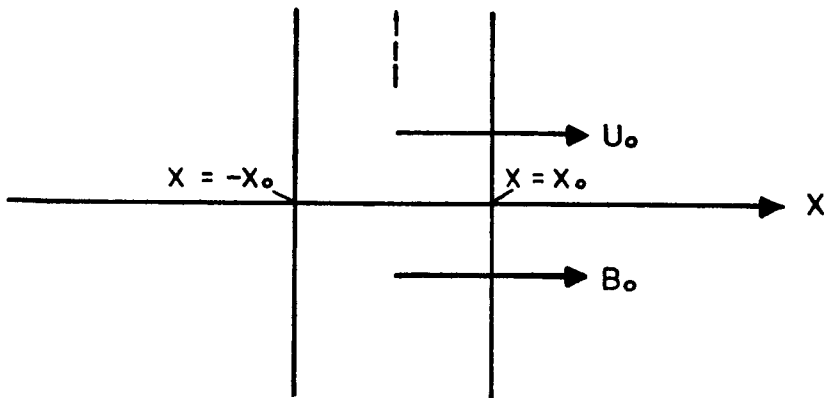

GRIDS IN A PLASMA

FIGURE 2

describing the kinetic theory approach to plasma problems, the electron fluid theory, upon which Rydbeck's work is based, will be presented.

Electron Fluid Theory

This theory treats the electrons as a fluid immersed in a uniform background of positive charge which is of such magnitude as to give a total neutral charge. The electrons of charge e and mass m are described by a particle density $n(\vec{x}, t)$ and a fluid velocity $\vec{u}(\vec{x}, t)$ of the particles. The dynamical fluid equations describing this system are the continuity equation

$$\frac{\partial n}{\partial t} + \nabla \cdot (n \vec{u}) = 0 \quad (2)$$

the force equation

$$\frac{\partial \vec{u}}{\partial t} + (\vec{u} \cdot \nabla) \vec{u} = \frac{e}{m} (\vec{E} + \vec{u} \times \vec{B}) - \frac{1}{mn} \nabla P \quad (3)$$

where P is the pressure of plasma, and the full set of Maxwell's Equations (presented in rationalized MKS units)

$$\nabla \cdot \vec{E} = \rho_e / \epsilon_0 \quad (4)$$

$$\nabla \cdot \vec{B} = 0 \quad (5)$$

$$\nabla \times \vec{E} + \frac{\partial \vec{B}}{\partial t} = 0 \quad (6)$$

$$\frac{1}{\mu_0} \nabla \times \vec{B} = \vec{J} + \epsilon_0 \frac{\partial \vec{E}}{\partial t} \quad (7)$$

where

$$\rho_e = e(n - n_0) \quad (8)$$

$$\vec{J} = en\vec{u} \quad (9)$$

and where n_0 is the equilibrium density of ions and electrons in the plasma.

Starting from this set of equations, Rydbeck³ obtained the solution to the physical problem previously described neglecting the pressure effect in equation (3).

In order to simplify the presentation of the impedance, let's define two quantities by the following equation

$$Z_p(\omega_0) = \frac{1}{\omega_0 C_0} \left[-j + \frac{X}{(1+X)^2} (\xi_1 + j \xi_2) \right] \quad (10)$$

where $j = \sqrt{-1}$, C_0 is the capacitance per unit area of an infinite parallel plate capacitor; $X = \frac{\omega_0^2}{\omega_p^2} \cdot \xi_1$ and ξ_2

will be called the plasma resistance and reactance respectively.

The plasma frequency, ω_p , is defined by

$$\omega_p^2 = \frac{e^2 n_0}{\epsilon_0 m} \quad (11)$$

As can be seen, $Z_p(\omega_0)$ has been divided into the impedance of the grid pair in free space plus what will be called the plasma impedance. The factor out front of the second term of equation 10 is merely a computation convenience. In terms of the separation between the grids, $C_0 = \epsilon_0/2x_0$.

Rydbeck's³ results in terms of these newly defined quantities are

$$\xi_1 = \frac{-1}{2\sqrt{X} \theta_0} \left[(1 - \cos a_+) - \frac{(1+\sqrt{X})^2}{(1-\sqrt{X})^2} (1 - \cos a_-) \right] \quad (12)$$

$$\xi_2 = -\frac{(1+\sqrt{X})}{(1-\sqrt{X})} - \left[\frac{1}{2\sqrt{X}\theta_0} \sin a_+ - \frac{(1+\sqrt{X})^2}{(1-\sqrt{X})^2} \sin a_- \right] \quad (13)$$

where

$$\theta_0 = \frac{2 \omega_0 x_0}{u_0}$$

$$a_+ = \theta_0 (1 + \sqrt{X})$$

$$a_- = \theta_0 (1 - \sqrt{X})$$

The significance of the above parameters will be discussed with the presentation of the results later on in this thesis.

Kinetic Theory (Landau-Vlasov Theory) of Plasmas

To describe the propagation of electromagnetic waves in a plasma, Vlasov² proposed that the collisionless kinetic equation (collisionless Boltzman equation) be coupled to Maxwell's equations. He assumed that the "external" forces in the kinetic equation, under whose influence the particles move, are produced by the average electric and magnetic fields produced by the motions of the particles themselves. In 1946, Landau¹ published his famous paper in which he improved the theory of self-oscillations begun by Vlasov and in which he did the first boundary value problem in the kinetic theory of a plasma. In Appendix C at the end of this thesis, Landau's boundary value problem is done by the mathematical method which will be presented in the next chapter.

The kinetic theory of a plasma first consists of a kinetic equation

$$\frac{\partial \mathcal{F}}{\partial t} + \vec{v} \cdot \frac{\partial \mathcal{F}}{\partial \vec{x}} + \frac{e}{m} [\vec{E} + \vec{v} \times (\vec{B} + \vec{B}_0)] \cdot \frac{\partial \mathcal{F}}{\partial \vec{v}} = \left(\frac{\partial \mathcal{F}}{\partial t} \right)_{\text{coll.}} \quad (14)$$

where \vec{B}_0 is an externally applied magnetic field, and \vec{E} and \vec{B} are the average fields produced by the motions of the electrons. Again as in the electron fluid theory, the frequency

of oscillations will be assumed to be so large that the ions will not be able to keep up with the oscillation, and therefore they will form a neutralizing background. When the collision term in (14) is assumed to be zero, this equation is called the Vlasov equation. For the major part of the analysis, we will assume a zero collision term, since we are assuming that the frequency of oscillation is a lot greater than the collision frequency in a plasma (an assumption which is true for most laboratory plasmas). When a collision term is necessary in our analysis, as to keep the impedance finite when $\omega_0 = \omega_p$, the following simple phenomenological non-conservative collision term will be used

$$\left(\frac{\partial \mathcal{F}}{\partial t} \right)_{\text{coll.}} = - \nu (\mathcal{F} - n_0 F_0(v)) \quad (14a)$$

where the collision frequency ν will be assumed to be velocity independent and $F_0(v)$ is some zero order velocity distribution of the electrons which does not have to be an equilibrium distribution. All that will be required is that the function is constant or steady over many time periods of the plasma oscillation. The set of Maxwell's Equations (4) through (7) completes the set of equations for the electron plasma if the current and charge density are defined as follows

$$\rho_e = e \int f d^3 v \quad (15)$$

$$\vec{j} = e \int \vec{v} f d^3 v \quad (16)$$

where

$$\mathcal{F} = n_0 F_0(\vec{v}) + f(\vec{x}, \vec{v}, t) \quad (17)$$

and

$$\int F_0(v) d^3 v = 1 \quad (18)$$

The plasma drift is included in this steady state distribution by specifying that

$$\vec{u}_0 = \int \vec{v} F_0(v) d v \quad (19)$$

As in the fluid theory, the ions are assumed to form a neutralizing background and do not participate in the electron oscillations since the motion is too fast for the heavy ions to follow.

In order to solve this equation a linearization procedure is used since equation (14) is a non-linear differential equation. The linearized form of (14) using equation (17) is

$$\frac{\partial f}{\partial t} + \vec{v} \cdot \frac{\partial f}{\partial \vec{x}} + \frac{e}{m} [\vec{E} + \vec{v} \times \vec{B}] \cdot \frac{\partial F_0}{\partial \vec{v}} + \frac{e}{m} (\vec{v} \times \vec{B}_0) \cdot \frac{\partial f}{\partial \vec{v}} = -\nu f$$

(20)

The set of equations (4) through (7) and (20) can be decoupled into a set which describes longitudinal waves and a set which describes transverse waves in the plasma. The longitudinal set of equations will be shown to be all that is needed to solve the physical problem described previously. In order to show that the electric field of the longitudinal waves can be written in terms of only a scalar potential, we will introduce the scalar and vector potentials into our equations.

$$\vec{B} = \nabla \times \vec{A} \quad \text{and} \quad \vec{E} = -\nabla\phi - \frac{\partial \vec{A}}{\partial t} \quad (21)$$

In order to show decoupling, let's first assume that the quantities \vec{B} , \vec{E} and f vary like

$$e \times p[j(\vec{k} \cdot \vec{x} - \omega t)] \quad (22)$$

Using (21), equations (4) through (7) and (20) become

$$\begin{aligned} (\omega - \vec{k} \cdot \vec{v} + j\nu)f + \frac{en_0}{m} [\vec{k}\phi - \omega\vec{A} + \vec{v} \times (\vec{A} \times \vec{k})] \cdot \frac{\partial F_0}{\partial \vec{v}} \\ + j \frac{e}{m} [\vec{v} \times \vec{B}_0] \cdot \frac{\partial f}{\partial \vec{v}} = 0 \end{aligned} \quad (23)$$

$$\vec{k} \cdot [\vec{k} \times \vec{A}] = 0 \quad (24)$$

$$\vec{k} \times [\vec{k} \times \vec{A}] = -\mu_0 \vec{J} + \frac{\omega}{c^2} [\vec{k}\phi - \omega\vec{A}] \quad (25)$$

$$\vec{k} \cdot [\vec{k}\phi - \omega\vec{A}] = \frac{\rho_e}{\epsilon_0} \quad (26)$$

$$\vec{k} \times [-\vec{k}\phi + \omega\vec{A}] = \omega \vec{k} \times \vec{A} \quad (27)$$

Equations (24) and (27) are identities, of course. The proper gauge to choose to show the decoupling, where the ϕ will describe the longitudinal mode and the \vec{A} will describe the transverse mode, is the coulomb gauge.

$$\nabla \cdot \vec{A} = 0 \quad \text{or} \quad \vec{k} \cdot \vec{A} = 0 \quad (28)$$

This makes equation (25) become

$$\vec{A}(k^2 - \frac{\omega^2}{c^2}) + \frac{\omega}{c^2} \vec{k} \phi = \mu_0 \vec{J} \quad (29)$$

and equation (26) becomes

$$k^2 \phi = \frac{\rho_e}{\epsilon_0} \quad (30)$$

If \vec{k} is dotted and crossed into equation (29), the resulting equations are respectively

$$\frac{\omega}{c^2} k^2 \phi = \mu_0 \vec{k} \cdot \vec{J} \quad (31)$$

$$\vec{k} \times \vec{A}(k^2 - \frac{\omega^2}{c^2}) = \mu_0 \vec{k} \times \vec{J} \quad (32)$$

Equation (32) described the transverse waves in the plasma and (30) and (31) describe the longitudinal waves. In order to prove the decoupling, we must now show that ρ and $\vec{k} \cdot \vec{J}$ are independent of \vec{A} and that $\vec{k} \times \vec{J}$ is independent of ϕ .

Using equation (20) and definitions (15) and (16), the current and density terms become:

$$\vec{J} = -\omega_p^2 \epsilon_0 \int \vec{v} d^3v \left[\frac{\vec{k}\phi - \vec{k}(\vec{v} \cdot \vec{A})}{\omega - \vec{k} \cdot \vec{v}} - \vec{A} \right] \cdot \frac{dF_0}{d\vec{v}} - j \frac{e}{m} \int \frac{\vec{v}(\vec{v} \times \vec{B}_0) \cdot \frac{\partial f}{\partial \vec{v}} d^3v}{\omega - \vec{k} \cdot \vec{v}} \quad (33)$$

$$\rho_e = -\omega_p^2 \epsilon_0 \int d^3v \left[\frac{\vec{k}\phi - \vec{k}(\vec{v} \cdot \vec{A})}{\omega - \vec{k} \cdot \vec{v}} - \vec{A} \right] \cdot \frac{dF_0}{d\vec{v}} - j \frac{e}{m} \int \frac{(\vec{v} \times \vec{B}_0) \cdot \frac{\partial f}{\partial \vec{v}} dv}{\omega - \vec{k} \cdot \vec{v}} \quad (34)$$

To show this decoupling the following set of assumptions are needed:

- 1) \vec{u}_0 is parallel to \vec{k}
- 2) $\lim_{|\vec{v}| \rightarrow \infty} F_0(\vec{v}) = 0$
- 3) $\vec{k} \cdot \vec{A} = 0$ (\vec{A} has no component in \vec{k} direction)
- 4) $F_0(\vec{v})$ is symmetric in \vec{v} perpendicular to the direction of \vec{k} .

In order to show that the last term in (34) and in the expression for $\vec{k} \cdot \vec{J}$ disappear the following additional assumptions are needed:

1) \vec{k} is parallel to \vec{B}_0

2) $\lim_{|\vec{v}| \rightarrow \infty} f(\vec{x}, \vec{v}, \vec{t}) = 0$

Using the listed set of properties and doing some simple integration by parts in velocity space, the current and density become

$$\rho = -\omega_p^2 \epsilon_0 \int d^3v \left[\frac{\vec{k} \cdot \phi}{\omega - \vec{k} \cdot \vec{v}} \right] \cdot \frac{dF_0}{d\vec{v}} \quad (35)$$

$$\vec{J} \cdot \vec{k} = -\omega_p^2 \epsilon_0 \int (\vec{v} \cdot \vec{k}) d^3v \left[\frac{\vec{k} \cdot \phi}{\omega - \vec{k} \cdot \vec{v}} \right] \cdot \frac{dF_0}{d\vec{v}} \quad (36)$$

$$\begin{aligned} \vec{J} \times \vec{k} = \omega_p^2 \epsilon_0 \int (\vec{k} \times \vec{v}) d^3v \left[\frac{\vec{k}(\vec{v} \cdot \vec{A})}{\omega - \vec{k} \cdot \vec{v}} - \vec{A} \right] \cdot \frac{dF_0}{d\vec{v}} \\ + \frac{j_m^e}{m} \int \frac{(\vec{k} \times \vec{v})(\vec{v} \times \vec{B}) \cdot \frac{\partial f}{\partial \vec{v}}}{\omega - \vec{k} \cdot \vec{v}} d^3v \end{aligned} \quad (37)$$

As can be seen this completely decouples the transverse from the longitudinal waves. The longitudinal and transverse electric fields are then given by the following equations:

$$\vec{E}_\parallel = -\nabla \phi \quad (38)$$

$$\vec{E}_t = - \frac{\partial A}{\partial t} \quad (39)$$

We also define transverse and longitudinal currents by

$$\vec{J} = \vec{J}_t + \vec{J}_\ell \quad (40)$$

where $\nabla \cdot \vec{J}_t = 0$

and $\nabla \times \vec{J}_\ell = 0$

The equations which describe the longitudinal wave are then

$$\frac{\partial f}{\partial t} + \vec{v} \cdot \frac{\partial f}{\partial \vec{x}} + \frac{en_0}{m} [-\nabla\phi] \cdot \frac{\partial F_0}{\partial \vec{v}} = -\nu f, \quad (41)$$

and $\nabla^2 \phi = -\rho_e/\epsilon_0$, (42)

$$\nabla \cdot (-\epsilon_0 \frac{\partial}{\partial t} \nabla \phi + \vec{J}_\ell) = 0 \quad (43)$$

Equations (42) and (43) are redundant. Either one can be used to describe the system with (41), and then the other equation is a consequence.

Boundary Value Problems

Landau and a host of other people after, following his lead, have done boundary value problems with time varying

forces by the method of Fourier transforms. They first eliminate the time derivatives in the equations by assuming that all dependent variables vary as $e^{j\omega_0 t}$ and then take a Fourier transform of the space coordinates. A problem arises in taking the inverse transform though. What is the proper contour to take for the inverse transform? The solutions of the one dimensional longitudinal wave problem by transform methods usually has the following type of solution

$$\phi(x, t) = \int_{-\infty}^{+\infty} \frac{\rho_0(k) e^{jkx} dk}{k^2 \epsilon_0 K(\omega_0, k)} \quad (44)$$

where the dispersion function is defined by

$$K(\omega, k) = 1 - \frac{\omega_p^2}{k^2} \int_{-\infty}^{+\infty} \frac{(dF_0/dv)dv}{v - \omega/k} \quad (45)$$

and $\rho_0(k)$ is the transform of the boundary conditions. These problems are done using the collisionless form of (41). As can be seen, the path of integration in the integral in Equation (45) passes through a singularity if k is real. Landau and others resolve this problem by saying ω_0 has a positive imaginary part due to the fact that the force was turned on in the past. Some deform the k -contour in (44) off the real axis so that k is complex in the integral in (45). These two methods turn out to be identical in

content and ultimately depend upon the initial value problem, causality and the radiation condition. This will be discussed thoroughly in the next chapter.

Another method of doing boundary value problems is to develop an orthogonal expansion for the set of equations. Shure^{4, 5} following Van Kampen⁶ and Case⁷ developed an expansion for the one dimensional problem where drifts are not encountered. This method has difficulties in that one has to develop a new orthogonal expansion and prove completeness for every different alteration that is made in the differential equations which describe the physical system.

Specific Statement of the Theoretical Problem

In light of the difficulties in both of the above procedures for doing boundary value problems of this type, an unambiguous method is to be sought for doing plasma drift problems using transforms. A generally useful method is also sought for introducing boundary values into the differential equations to make the transform method easy to use.

II. Theoretical Method

Simple Physical Problem

Let us first consider the physical problem for the zero temperature stationary plasma from the point of view of the fluid theory. In the solution of this problem, the introduction of boundary conditions by the use of generalized functions will be demonstrated. Let's first define two generalized functions and the relation between them. These "functions" and their theory are thoroughly discussed by Lighthill⁸, and Vander Pol and Bremmer⁹. The first is the Heaviside⁹ unit step function which is defined by

$$U(x - x_0) = \begin{cases} 1 & (x - x_0) > 0 \\ 0 & (x - x_0) < 0 \\ 1/2 & (x - x_0) = 0 \end{cases} \quad (46)$$

The second is the δ -function which is defined by

$$\int_a^b f(x) \delta(x - x_0) dx = \begin{cases} f(x_0) & \text{if } a < x_0 < b \\ 0 & \text{if } x_0 < a \text{ or } x_0 > b \end{cases}$$

where $f(x)$ is any arbitrary continuous function. These two functions are related to each other by the fact that

$$\frac{d U(x - x_0)}{d x} = \delta (x - x_0) \quad (47)$$

We will now utilize these two functions to incorporate boundary conditions into the fluid equations.

Equation (43) represents a very general result and is a statement of the continuity of the total current; that is, that the sum of the conduction and displacement currents is a constant in space. It follows immediately by taking the divergence of equation (7). Since a current is coming out of one grid and into the other, the total current between the grids must be equal to this current in the external circuit. In the region outside the grids the total current is zero because there are no sources of current other than the grids. Expressing the above statement in symbols yields the following equation

$$- \epsilon_0 \frac{\partial}{\partial t} \nabla \phi + \vec{J} = I_0 e^{j\omega_0 t} \hat{i} [U(x + x_0) - U(x - x_0)] \quad (48)$$

where \hat{i} is the unit vector in the x-direction.

The particle continuity equation (2) is derived under the assumption that there were no sources or sinks in the system. Including the effect of the grids, the continuity equation becomes

$$\frac{\partial n}{\partial t} + \nabla(n \vec{u}) = \frac{I_0}{e} e^{j\omega_0 t} [\delta(x + x_0) - \delta(x - x_0)] \quad (49)$$

Because n and \vec{u} are both dependent variables, equation (49) and the force equation (3) are non-linear and therefore will be linearized. Since the external driving term in equation (48) is only in the x -direction this problem reduces to a one dimensional space problem in the x -direction. The linearized, one dimensional forms of (48), (49) and (3), assuming that the drift of the plasma is zero, are then

$$-\epsilon_0 \frac{\partial}{\partial t} \frac{\partial \phi}{\partial x} + en_0 u = I_0 e^{j\omega_0 t} [U(x + x_0) - U(x - x_0)] \quad (50)$$

$$\frac{\partial n_1}{\partial t} + n_0 \frac{\partial}{\partial x} u = \frac{I_0}{e} e^{j\omega_0 t} [\delta(x + x_0) - \delta(x - x_0)] \quad (51)$$

$$\frac{\partial u}{\partial t} = \frac{e}{m} \left[-\frac{\partial \phi}{\partial x} \right] \quad (52)$$

Assuming that ϕ , u and n , vary as $e^{j\omega_0 t}$ and combining equations (50) and (52), the three stated quantities

have the following solutions

$$E_{\ell} = -\frac{\partial\phi}{\partial x} = \frac{I_o}{j\epsilon_o} e^{j\omega_o t} \frac{\omega_o}{(\omega_o^2 - \omega_p^2)} [U(x + x_o) - U(x - x_o)] \quad (53)$$

$$e n_o u = -I_o \frac{\omega_p^2}{(\omega_o^2 - \omega_p^2)} [U(x + x_o) - U(x - x_o)] \quad (54)$$

$$e n_1 = \frac{I_o e^{j\omega_o t}}{j} \frac{\omega_o}{(\omega_o^2 - \omega_p^2)} [\delta(x + x_o) - \delta(x - x_o)] \quad (55)$$

(As can be seen from Equation (53) the change in \underline{E} across the grids is given by

$$\nabla E_{\ell} = \frac{\pm \omega_o I_o e^{j\omega_o t}}{\epsilon_o j (\omega_o^2 - \omega_p^2)} \quad (56)$$

which is the familiar boundary value for the normal electric field across a sheet of charge obtained from equation (55).)

If now we integrate (53) from one grid to another to get $\Delta\phi$, the impedance defined by (1) of the grid pair in this description becomes

$$Z_p(\omega_o) = \frac{2x_o}{j\epsilon_o} \frac{\omega_o}{\omega_o^2 - \omega_p^2} = \frac{-j}{\omega_o C_o} \frac{1}{(1 - X)} \quad (57)$$

this makes (from Equation (10))

$$\xi_1 = 0 \quad \text{and} \quad \xi_2 = - \frac{(1 + \sqrt{X})}{(1 - \sqrt{X})} \quad (58)$$

Notice that ξ_2 in (58) is the first term in Rydbeck's expression (13) for ξ_2 . Rydbeck's results contain the effects of the drift of the plasma, which we have neglected above, and reduce to our results when the drift u_0 is made to go to zero.

The above results were relatively easy to obtain. When we try to do the problem by the kinetic theory of a plasma using transforms, problems arise as had been stated at the end of the previous chapter with regard to making the integral in Equation (45) well defined. The specification of the principle of causality will remove the ambiguity from Equation (45). The discussion in the next section involving transforms, causality, and the radiation condition will define causality precisely and will show how it can be incorporated into the mathematics very simply.

Transforms and Causality

Two of the most frequently used transforms in wave theory are the Fourier and Laplace transforms. The Laplace transform is used most frequently to do initial value problems;

that is, certain initial conditions are specified on the set of differential equations and one wants to know how the system behaves some time after $t = 0$. The Laplace transform is the natural set of transforms to do this problem. If $h(t)$ is some function of time for which (59) converges, then its transform in ω -space can be defined by

$$H(\omega) = \int_0^{\infty} h(t) e^{-j\omega t} dt \quad (59)$$

The inverse transform is obtained from

$$h(t) = \frac{1}{2\pi} \int_C H(\omega) e^{j\omega t} dt \quad (60)$$

where the contour C is a contour below all poles in the complex plane -- usually below the axis of reals going from $\omega = -j\delta_1 - \infty$ to $\omega = -j\delta_1 + \infty$ as shown in Figure 3. This contour below the axis of reals insures that the integral will be convergent. As can be seen the time integral only goes from 0 to ∞ . There is an implicit assumption here that $h(t) = 0$ when $-\infty < t < 0$. In fact this is the assumption that is used to derive the Laplace transform from the Fourier transform. What we are saying when we use this transform is that there is no disturbance in the medium until $t = 0$ when some force excites it. The inverse transform then gives us the solution to the set

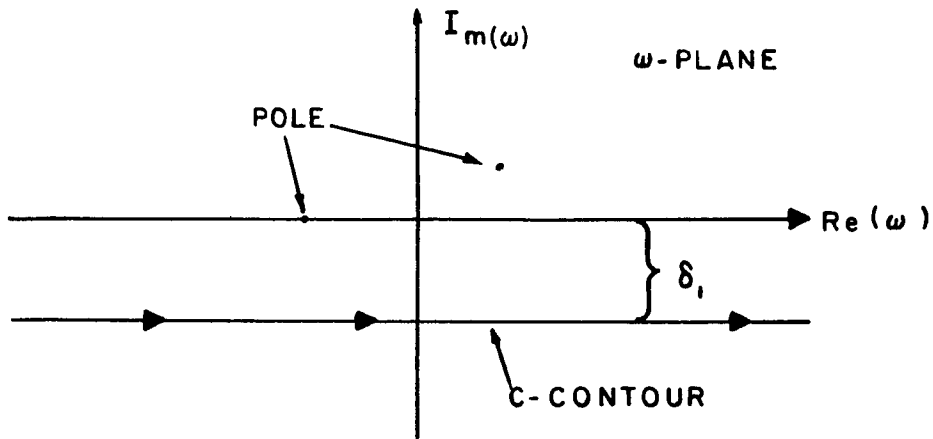

ω -PLANE CONTOUR

FIGURE 3

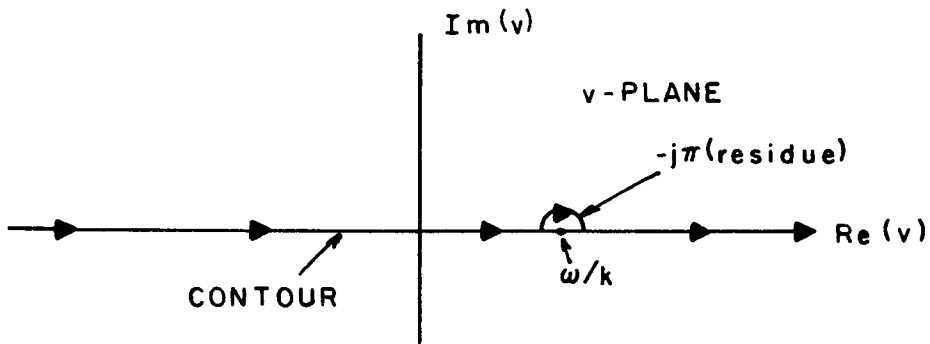

v -CONTOUR FOR $K+$
(a)

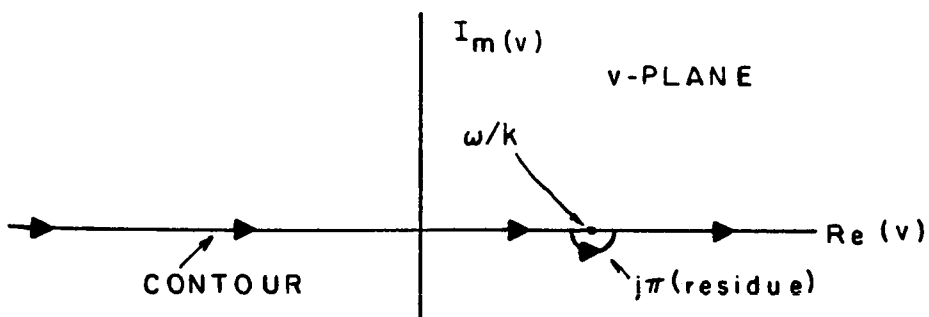

v -CONTOUR FOR $K-$
(b)

FIGURE 4

of the differential equations after $t = 0$.

The use of the Laplace transform described above is naturally connected to the principles of causality. The definition of the principle which pertains here is that prior to the application of a force on the plasma, no disturbance is observed in the medium. This is the appropriate definition since we are looking for the steady state response of a system to a sinusoidally varying force which has been turned on at some time in the past, before which the system was undisturbed. As can be seen the use of the Laplace transform embodies in it the principle of causality just stated. Another discussion of the application of causality to plasma oscillation problems has recently been discussed by H. Gelman¹⁰ who approaches the problem from the theory leading to the "Kramers-Kronig dispersion relations". [Note: The term dispersion relation used here has a different meaning than that used to describe equation (45).] This different approach is not at all surprising since the "Kramers-Kronig dispersion relations" are derived using the principle of causality.

The statement made above about the "turning on of the force in the past" is exactly the justification that Landau¹ used to say that ω has a small negative imaginary part which makes the integral in the dispersion function well defined. More will be said about this later.

It could well be asked whether taking the Laplace transform in position space -- where x is substituted for t and its transform variable k is substituted for ω -- is warranted from the physical stand point. In this way one might be able to introduce a boundary value of the system at $x = 0$. The success of this method would depend on whether it were physically possible to have $h(x) = 0$ for $-\infty < x < 0$. This is not generally possible as Sturrock¹¹ points out. Rolland¹² has developed a method of finding an inverse transform starting out with the Laplace transform in space by throwing out parts of the solution which do not satisfy the physical conditions. However, he says that this method is not generally applicable for plasmas.

There is no natural way to introduce boundary values which are intrinsic to the classical exponential Fourier transform, however this transform includes the entirety of space from $-\infty$ to $+\infty$ and therefore does not possess the same difficulty that the Laplace transform does. There is a difficulty however that one must assume that a function and its transform must both be square integrable. This limits the class of solutions which can be handled by this method. The development of the "theory of distributions" by Laurent Schwartz, which was expounded by Lighthill⁸ as the "theory

of generalized functions" and which is used extensively by Van Der Pol and Bremmer⁹ in their book on Operational Calculus, extended the class of functions which have lent themselves to the solution by the transform method and made the introduction of boundary conditions using transform theory possible. The introduction of boundary conditions into the differential equation was demonstrated in the previous section. The extension of the class of functions amenable to the Fourier transform method is demonstrated in Appendix C in doing Landau's problem by these methods.

The use of the Laplace transform in time is also related to the radiation condition in a forced oscillation boundary value problem. When you solve a problem using the Laplace transform you are saying that at some time ($t = 0$) you turn on a force. This disturbance then is located in the vicinity of the radiating oscillator at $t = 0$ and progresses away from the oscillator as time goes on. The Laplace transform then gives only outwardly going disturbances as we take $t \rightarrow \infty$ and transients die out.

This section serves as an introduction and a justification for the use of the Laplace and Fourier transforms in the next section to solve the physical problem by the kinetic theory of plasmas.

Kinetic Theory Problem

The set of differential equations which can be used to solve the physical problem using the kinetic theory are equation (48) or (42) and the one dimensional form of equation (41)

$$\frac{\partial f}{\partial t} + v \frac{\partial f}{\partial x} + \frac{en_0}{m} \left[- \frac{\partial \phi}{\partial x} \right] \frac{dF_0}{dv} = -vf \quad (61)$$

where v is now the x -component of \vec{v} . Since we will now only be dealing with the one dimensional form of the differential equations where the other components of \vec{v} will be present, the F_0 and f will now be understood to be the previously defined function integrated over the other two components of velocity space. With this change, the current and charge densities are now defined by

$$\rho_e = e \int_{-\infty}^{+\infty} f dv + \frac{I_0 e^{j\omega_0 t}}{j\omega_0} [\delta(x + x_0) - \delta(x - x_0)] \quad (62)$$

$$J = e \int_{-\infty}^{+\infty} v f dv \quad (63)$$

where J is the current in the x -direction. Again the justification of only using the one dimensional form of the equations is that the external force on the system only produces changes in the x -direction as can be seen from

equation (48) whose one dimensional form is

$$-\epsilon_0 \frac{\partial \phi}{\partial x \partial t} + J = I_0 e^{j\omega_0 t} [U(x + x_0) - U(x - x_0)] \quad (64)$$

The current in (63) is essentially defined as before. The charge density ρ_e is redefined, however, to include an "external" charge density. Redefining ρ_e in this way eliminates the necessity of including the external sources in the kinetic equation (61) as was done for the continuity equation. One way of interpreting (62) is that the charge at any point is made up of the external charge given by the second term and the plasma charge given by the first term. This is an oversimplified view of what is happening in the system however, since physically the two charge densities are really indistinguishable. Equation (64) or, alternatively, the one dimensional form of (42) can be used with (61) to obtain the solution of the physical problem. The one dimensional form of (42) is

$$\frac{\partial^2 \phi}{\partial x^2} = -\frac{e}{\epsilon_0} \int_{-\infty}^{+\infty} f \, d v + \frac{I_0 e^{j\omega_0 t}}{j\omega_0} [\delta(x + x_0) - \delta(x - x_0)] \quad (65)$$

It will be used instead of (64) to solve the problem.

It can be shown that equations (65) and (64) give the one dimensional continuity equation without sources. The following Fourier transform in space and Laplace transform in time will be used to solve the problem:

$$\left\{ \begin{array}{l} \phi_1(k, \omega) \\ f_1(k, v, \omega) \end{array} \right\} = \int_{-\infty}^{+\infty} dx \int_0^{\infty} dt e^{+j(kx - \omega t)} \left\{ \begin{array}{l} \phi(x, t) \\ f(x, v, t) \end{array} \right\} \quad (66)$$

$$\left\{ \begin{array}{l} \phi(x, t) \\ f(x, v, t) \end{array} \right\} = \frac{1}{(2\pi)^2} \int_C d\omega \int_{-\infty}^{+\infty} dk e^{-j(kx - \omega t)} \left\{ \begin{array}{l} \phi_1(k, \omega) \\ f_1(k, v, \omega) \end{array} \right\} \quad (67)$$

where the contour C is the contour defined in figure 3 below all poles of the functions ϕ_1 and f_1 in the complex ω -plane. The method will consist in calculating $\phi(-x_0) - \phi(x_0)$ and then throwing out all transient terms since we are only interested in the steady state part of the solution. Multiplying equations (61) and (65) by $e^{j(kx - \omega t)}$ and integrating x over the range $-\infty < x < +\infty$ and integrating t over the range $0 < t < \infty$, the following transform

equations are obtained

$$\omega f_1 - v k f_1 + \frac{en_0}{m} k \phi_1 \frac{dF_0}{dv} = + j v f_1 \quad (68)$$

$$-k^2 \phi_1 = \frac{e}{\epsilon_0} \int_{-\infty}^{+\infty} f_1 dv - \frac{I_0 2j}{\omega_0 (\omega_0 - \omega)} \sin k x_0 \quad (69)$$

Equation (68) does not have an initial value in it because we have assumed it to be zero. An initial value would give transient terms which are not of interest here. Further, let's assume v is equal to zero since in our analysis we are assuming $\omega_0 \gg v$. v will be brought back into our calculation in one specific instance when it will be needed to keep the plasma resistance finite. Since ϕ_1 is dependent of v , ϕ_1 can be solved for if f_1 is solved (68) and inserted in (69) to give

$$\phi_1(k, \omega) = \frac{2j I_0}{\epsilon_0 \omega_0 (\omega_0 - \omega)} \frac{\sin k x_0}{k^2 K(\omega, k)} \quad (70)$$

where

$$K(\omega, k) = 1 - \frac{\omega_p^2}{k^2} \int_{-\infty}^{+\infty} \frac{\frac{dF_0}{dv} dv}{v - \omega/k} \quad (71)$$

Taking the transform of (70) and then computing

$\Delta\phi = \phi(-x_0) - \phi(x_0)$ we get

$$\Delta\phi = \frac{4I_0}{\epsilon_0 (2\pi)^2} \int_C \frac{d\omega e^{j\omega t}}{\omega_0 (\omega_0 - \omega)} \int_{-\infty}^{+\infty} \frac{\sin^2 k x_0 dk}{k^2 K(\omega, k)} \quad (72)$$

The solution for the impedance is then

$$Z_p(\omega_0) = \lim_{t \rightarrow \infty} \frac{4}{\omega_0 \epsilon_0 (2\pi)^2} \int_C \frac{d\omega e^{j(\omega - \omega_0)t}}{(\omega_0 - \omega)} \int_{-\infty}^{+\infty} \frac{\sin^2 k x_0 dk}{k^2 K(\omega, k)} \quad (73)$$

The Dispersion Function

The dispersion function $K(\omega, k)$ defined by (71) is an important function that determines the characteristics of solution (73). The use of the combined Fourier-Laplace transforms determines precisely $K(\omega, k)$ for our problem. Since the ω -contour of the inverse transform is below the axis of reals, ω in the definition of $K(\omega, k)$ in equation (71) is complex with a negative imaginary part (the stipulation that Landau¹ made). This means that the v -integral in equation (71) is well defined since it does not pass through any singularity when k is real (Note: It must be kept clear in one's mind that there are three complex planes to deal with; the v -plane the ω -plane and the

k-plane. Unless these three planes are kept distinct a great deal of confusion can result.) Since the integration contour of k is real, the analysis of $K(\omega, k)$ will be made for real k . When k is positive ω/k is below the axis of reals in the v -plane and when k is negative ω/k is above the axis of reals in the v -plane. If ω/k approaches the axis of reals from above and below two different limits are obtained for $K(\omega, k)$. $K(\omega, k)$ can then be related to two different analytic functions for k positive and negative

$$K(\omega, k) = \begin{cases} K_+(\omega, k, u_0) & \text{for } k > 0 \\ K_-(\omega, k, u_0) & \text{for } k < 0 \\ 1 - X & \text{for } k = 0 \end{cases} \quad (74)$$

These functions K_+ and K_- can be analytically continued to the axis of reals in the ω -plane by the use of the following limit formula

$$\lim_{\epsilon \rightarrow +0} \int_{-\infty}^{+\infty} \frac{G(x) dx}{x - x_0 \pm j\epsilon} = p \int_{-\infty}^{\infty} \frac{G(x) dx}{x - x_0} \mp j\pi G(x_0) \quad (75)$$

where p means Cauchy Principle value of the integral about the pole $x = x_0$.

Using (75) we obtain that the analytic continuation of K_+ and K_- to the axis of reals in the ω -plane becomes

$$\begin{aligned}
K_{\pm}(\omega, k, u_0) &= 1 - \frac{\omega^2}{k^2} \mp p \int_{-\infty}^{+\infty} \frac{dF_0}{dv} \frac{dv}{v + u_0 - \omega/k} \\
&\pm j\pi \frac{\omega^2}{k^2} \left(\frac{dF_0}{dv} \right)_{v = \omega/k - u_0} \quad (76)
\end{aligned}$$

The v -integration has been translated by $v \rightarrow v + u_0$ so as to make F_0 have its mean value at $v = 0$. The limits of analytic continuation can be schematically represented by the v -contours shown in figures 4.a and 4.b for K_+ and K_- respectively -- the semicircles representing $1/2$ the residue about the poles.

Next K_{\pm} will be analyzed for positive real ω in the entire k -plane since this will be all that is needed to do the problem as will be shown later. K_+ and K_- are defined initially in their respective half planes in terms of $K(\omega, k)$. If $k = k_R + jk_I$, then $K(\omega, k) = K_+(\omega, k, u_0)$ for $k_I > 0$ and $K(\omega, k) = K_-(\omega, k, u_0)$ for $k_I < 0$. (Note: $K(\omega, k)$ is K_- or K_+ depending on whether ω/k has a positive or negative imaginary part respectively.) To discuss K_+ and K_- as analytic functions in the entire k -plane, we must be able to find functions which suitably continue K_+ and K_- to the rest of the complex plane. These analytic continuations are accomplished by defining

$$K_+(\omega, k, u_0) = K(\omega, k) + 2j \pi \frac{\omega_p^2}{k^2} \left(\frac{dF_0}{dv} \right)_{v=\omega/k-u_0} k_I < 0 \quad (77)$$

$$K_-(\omega, k, u_0) = K(\omega, k) - 2j \pi \frac{\omega_p^2}{k^2} \left(\frac{dF_0}{dv} \right)_{v=\omega/k-u_0} k_I > 0 \quad (78)$$

It is easy to see that analytically continuing equations (77) and (78) to the k -axis of reals by (75) yields (76). This is all that is needed to prove that (77) and (78) are the analytic continuations of K_+ and K_- to the entire complex k -plane.

Knowing the above facts the following interesting relations between these two functions result (they will be useful in proving a few theorems):

$$K_+^*(\omega, k, u_0) = K_-(\omega, k^*, u_0) \quad (79)$$

and

$$K_-(\omega, -k, u_0) = K_+(\omega, k, u_0) \quad (80)$$

where $*$ denotes the complex conjugate. Now the following theorems, useful in the understanding of the theory, will be proved.

Theorem I: k_i is a zero of $K_+(\omega, k, u_0)$ if and only if k_i^* is a zero of $K_-(\omega, k, u_0)$.

This follows immediately from relation (79). The zero of a function is defined by

$$K_+(\omega, k_i, u) = 0 \quad (81)$$

Taking the complex conjugate of equation (81) and using (79) we obtain

$$K_-(\omega, k_i^*, u) = 0 \quad (82)$$

The converse follows similarly.

Corollary I: k_i is a zero of $K_+(\omega, k, u_0)$ if and only if $-k_i^*$ is a zero of $K_+(\omega, k, -u_0)$.

This follows directly from Theorem I and relation (80).

There may be an infinite number of k_i zeros to K_+ or K_- as when $F_0(v)$ is a Maxwellian distribution. But no matter how many zeroes of K_+ exist there is one, called the characteristic zero, which appears in the left half of the upper k -plane when $\omega < \omega_p$. This is proven in Appendix D.

General Form of the Solution

Taking the limit $t \rightarrow \infty$ in equation (73) means that the steady state solution, which exists after the transients have become negligible, is being sought. It is well known

that self-oscillation results due to a single hump distribution $F_0(v)$ decays in time. The initial value effects due to the turning on of the oscillator are self-oscillation effects and damp out. Therefore the steady state result which is time independent is due to the pole at $\omega = \omega_0$. Therefore by closing the ω -contour through the upper ω -plane by means of a semicircle whose contribution tends to zero as the radius of the semicircle tends to infinity, we get the steady state result of the ω -integration which is 2π times the residue of the pole at $\omega = \omega_0$. Any other poles or cuts in the upper ω -plane must yield transient terms.

This result is the same as would have been obtained if Landau's method of assuming that all dependent variables vary in time as $e^{j\omega_0 t}$ were used instead of using the Laplace transform. As we have shown Landau's assumption to make $K(\omega, k)$ well defined is equivalent to using the Laplace transform in time.

The general form of the solution will be investigated now. Evaluating the ω -contour as the residue of the $\omega = \omega_0$ pole, equation (72) becomes

$$Z_p(\omega_0) = \frac{-j 2}{\omega_0 \epsilon_0 \pi} \int_{-\infty}^{+\infty} \frac{\sin^2(k x_0) dk}{k^2 K(\omega_0, k)} \quad (83)$$

The reason for wanting to know all the relations described in the previous section was to make the k-integration more susceptible to the Mittag-Leffler¹³ partial fraction expansion theorem which allows us to show the general structure of the solution. The k-integral in (83) can be rewritten as

$$\int_{-\infty}^{+\infty} \frac{\sin^2(k x_0) dk}{k^2 K(\omega_0, k)} = \int_{-\infty}^0 \frac{\sin^2(k x_0) dk}{k^2 K_-(\omega_0, k, u_0)} + \int_0^{\infty} \frac{\sin^2(k x_0) dk}{k^2 K_+(\omega_0, k, u_0)} \quad (84)$$

Transforming the integration variable of the first integral of the right hand side of (84) by $k \rightarrow -k$ equation (84) becomes

$$\int_0^{\infty} \frac{\sin^2(k x_0) dk}{k^2 K(\omega_0, k)} = \int_0^{\infty} \frac{\sin^2(k x_0) dk}{k^2} \left[\frac{1}{K_+(\omega_0, k, u_0)} + \frac{1}{K_+(\omega_0, k, -u_0)} \right] \quad (85)$$

The following modified partial fraction expansion can be made.

$$\frac{1}{k^2 K_+(\omega_0, k, u_0)} = \frac{A_0}{k^2} + \sum_{i=1}^m \frac{B_i}{k (k - k_i)} \quad (86)$$

$$\frac{1}{k^2 K_+(\omega_0, k, -u_0)} = \frac{B_0}{k^2} + \sum_{i=1}^m \frac{B_i}{k (k + k_i^*)} \quad (87)$$

where $K_+(\omega_0, k, u_0)$ has m zeroes (m may be infinite). The justification for writing (86) and (87) is made in Appendix A. By using properties (79) and (80) to relate B_i to A_i and evaluating the residues at $k = k_i$ of both sides of (86), the coefficients become

$$A_0 = B_0 = \frac{1}{1-X}$$

$$B_i^* = A_i = \frac{1}{k_i} \left[\frac{1}{\frac{d K_+(\omega_0, k, u_0)}{d k}} \right]_{k=k_i} = \frac{\omega_p \frac{\partial k_i}{\partial \omega_p}}{2 k_i} \quad (88)$$

Integral (85), using (86), (87) and (88), becomes now

$$\int_{-\infty}^{\infty} \frac{\sin^2(kx_0) dk}{k^2 K(\omega_0, k)} = \frac{\pi x_0}{(1-X)} + \sum_{i=1}^m \left[A_i \int_0^{\infty} \frac{\sin^2(kx_0) dk}{k(k-k_i)} + A_i^* \int_0^{\infty} \frac{\sin^2(kx_0) dk}{k(k+k_i^*)} \right] \quad (89)$$

The zeroes k_i and $-k_i^*$ are symmetric about the imaginary axis below the axis of reals except for two characteristic zeroes k_i and $-k_i^*$ which migrate above the axis of reals when ω_p^2 / ω_0^2 becomes greater than 1. A proof which demonstrates that one zero of $K_+(\omega_0, k, u_0)$ appears above the axis of reals when $X > 1$ and $u_0 \geq 0$, and on the imaginary axis if $u_0 = 0$ is presented in Appendix D.

The following identities relating the integrals of (89) to known functions will be useful.

$$\int_0^{\infty} \frac{\sin^2(kx_0) dk}{k(k+\beta)} = \frac{1}{2\beta} [\gamma + \ln(2x_0\beta) - g_0(2x_0\beta)] \quad (90)$$

where $|\text{Arg } \beta| < \pi$ and $\gamma = \text{Euler's constant}$. $g_0(2x_0\beta)$ is one of the two co-functions of the sine and cosine integrals which are described thoroughly in Appendix A. It is useful for computational purposes to have the real part of the argument of $g_0(z)$ positive. The following relation makes this always possible.

$$g_0(-z) = g_0(z) + \pi j \text{sgn}(z_I) \left[e^{-|z_I|} + jzr \text{sgn}(z_I) \right] \quad (91)$$

where $z = zr + j z_I$

and where

$$\text{sgn}(x) = \begin{cases} +1 & x > 0 \\ -1 & x < 0 \\ 0 & x = 0 \end{cases} \quad (92)$$

One more relation, determining the complex conjugate of $g_0(z)$ and being useful in relating the two integrals of the i th term, is

$$g_0(z^*) = g_0^*(z) \quad (93)$$

where $g_o(Z) = Rg_o(z) - j I g_o(z)$

First of all, we will assume that the real and imaginary parts of k_i are negative where $k_i = -a_i - jb_i$, therefore $-k_i^* = +a_i - jb_i$. (a_i and b_i are positive.) Applying relation (90) to the integrals of the i th term and applying relation (91) we obtain

$$T_i = A_i \int_{-\infty}^{+\infty} \frac{\sin^2(kx_o) dk}{k(k - k_i)} = \frac{A_i}{-2k_i} \left[\gamma + \ln 2x_o \rho_i + j \theta_i - g_o(2x_o [a_i + b_i j]) + \pi_j e^{-b_i + ja_i} \right] \quad (94)$$

$$S_i = A_i^* \int_{-\infty}^{+\infty} \frac{\sin^2(kx_o) dk}{k(k + k_i^*)} = \frac{A_i}{2k_i^*} \left[\gamma + \ln 2x_o \rho_i - j \theta_i - g_o(2x_o [a_i - b_i j]) \right] \quad (95)$$

where $\rho_i = \sqrt{a_i^2 + b_i^2}$ and $\theta_i = \text{Arctan} \frac{b_i}{a_i}$

Adding equations (94) and (95) gives

$$T_i + S_i = R_e \left(\frac{A_i}{k_i} \right) \left[j \left(\frac{\pi}{2} - \theta_i \right) - j I g_o(2x_o [a_i + jb_i]) - \frac{\pi}{2} j e^{-b_i + ja_i} \right] - j \text{Im} \left(\frac{A_i}{k_i} \right) \left[\gamma + \ln(2x_o \rho_i) - R g_o(2x_o [a_i + jb_i]) + \frac{\pi}{2} j e^{-b_i + ja_i} \right] \quad (96)$$

Second of all, we will consider the characteristic zeros, defined by k_1 for $\frac{\omega^2}{\omega_0^2} = X > 1$. They will be written as

$$k_1 = -a_1 + jb_1$$

$$-k_1^* = +a_1 + jb_1$$

where a_1 and b_1 are positive.

Applying relation (90) to the integrals of the i th term we obtain

$$T_1 = \frac{A_1}{-2k_1} \left[\gamma + \ln(2x_0 \rho_1) - j\phi_1 - g_0(2x_0[a_1 - b_1j]) \right] \quad (97)$$

$$S_1 = \frac{A_1^*}{2k_1^*} \left[\gamma + \ln 2x_0 \rho_1 + j(\phi_1 - \pi) - g_0(2x_0[a_1 + jb_1]) \right. \\ \left. + j\pi e^{-b_1 + ja_1} \right] \quad (98)$$

These equations will be used in the next section to obtain $Z_p(\omega_0)$ for a particular zero-order distribution function.

III. Calculations and Results

Zero order Distributions and Zeroes

It could be suggested that an analysis could be made for a zero order velocity distribution which is an equilibrium distribution with a drift such as a maxwellian. However, due to the fact that K_+ has an infinite number of zeroes when $F_0(v)$ is an equilibrium distribution such as a maxwellian, it would be extremely difficult to do a complete analysis of $Z_p(\omega_0)$. In order to obtain the gross features of $Z_p(\omega_0)$ as a function of the various parameters, a simpler zero order distribution will be used, namely the Lorentzian shaped distribution,

$$F_0(v) = \frac{1}{\pi\sigma} \left[\frac{(v - u_0)^2}{\sigma^2} + 1 \right]^{-1} \quad (99)$$

where σ represents the width (and therefore is analogous to the temperature effects) of the distribution and where v is the x-component of the velocity vector. This single humped distribution fulfills the symmetry requirements imposed by the preceding theoretical discussion. The usefulness of (99) exists in the fact that it produces simple results for $K_+(\omega_0, k, u_0)$, namely

$$K_+(\omega_0, k, u_0) = 1 - \frac{\omega_p^2}{[k(u_0 + j\sigma) - \omega_0]^2} \quad (100)$$

whose zeroes are

$$k_1 = \frac{(\omega_0 - \omega_p)(u_0 - j\sigma)}{u_0^2 + \sigma^2}$$

$$k_2 = \frac{(\omega_0 + \omega_p)(u_0 - j\sigma)}{u_0^2 + \sigma^2} \quad (101)$$

(Note that k_1 is the characteristic zero previously discussed.)

The next section will show the details of the calculation for $Z_p(\omega_0)$ using k_1 and k_2 .

Impedance of a Grid Pair in a Plasma

Using relations (96), (97) and (98) of the last chapter and relation (10) defining the plasma resistance and impedance, ξ_1 and ξ_2 due to (99) become

$$\xi_1 = \frac{-1}{\pi\sqrt{X}\theta_0} \left((\phi - \gamma M) \left[\frac{4\sqrt{X}}{(1-\sqrt{X})^2} \right] + M \ln \rho_+ - \left(\frac{1+\sqrt{X}}{1-\sqrt{X}} \right)^2 M \ln \rho_- \right.$$

$$+ \operatorname{I}g_0(a_+ [1-jM]) + M \operatorname{R}g_0(a_+ [1-jM]) - \left(\frac{1+\sqrt{X}}{1-\sqrt{X}} \right)^2 [\operatorname{I}g_0(|a_-| [1-jM])$$

$$+ M \operatorname{R}g_0(|a_-| [1-jM])] - \frac{1}{2\sqrt{X}\theta_0} \left(1 - e^{-b_+} (\cos a_+ - M \sin a_+) \right.$$

$$\left. - \left(\frac{1+\sqrt{X}}{1-\sqrt{X}} \right)^2 [1 - e^{-|b_-|} (\cos |a_-| - M \sin |a_-|)] \right) \quad (102)$$

$$\xi_2 = \frac{-(1+\sqrt{X})}{(1-\sqrt{X})} - \frac{1}{2\theta_0\sqrt{X}} \left(e^{-b_+} (\sin a_+ - M \cos a_+) + M \right)$$

$$+ \frac{\operatorname{sgn}(a_-)}{2\sqrt{X}\theta_0} \left(\frac{1+\sqrt{X}}{1-\sqrt{X}} \right)^2 \left(e^{-|b_-|} (\sin |a_-| - M \cos |a_-|) + M \right) \quad (103)$$

where θ_0 is defined after equation (13) and where

$$M = \frac{\sigma}{u_0}$$

$$\phi = \text{Arctan } M$$

$$a_{\pm} = \frac{\theta_0 (1 \pm \sqrt{X})}{1 + M^2}$$

$$\rho_{\pm} = |a_{\pm}| \sqrt{1 + M^2}$$

When $M \rightarrow 0$, that is when the velocity spread becomes infinitesimal with respect to the drift of the plasma, it can be easily seen that equations (102) and (103) become the same as Rydbeck's results (12) and (13) if one realizes that

$$\lim_{M \rightarrow 0} \begin{cases} \text{I}g_0(a_{\pm}[1 - Mj]) = 0 \\ \text{R}g_0(a_{\pm}[1 - Mj]) = \text{finite value} \end{cases} \quad (104)$$

Two particular limits of (102) and (103) are of special interest, that is, the limit as $X \rightarrow 0$ (the driving frequency limit) and the limit as $X \rightarrow 1$ (the driving frequency equals the plasma frequency). It is not at all obvious, at first glance, that ξ_1 and ξ_2 converge to finite quantities in these limits. It turns out that there are no problems as $X \rightarrow 0$. ξ_1 and ξ_2 are both finite in this limit.

$$\lim_{X \rightarrow 0} \xi_1 = \frac{4}{\pi \theta_0} \left\{ \text{Ig}(a_0 [1-Mj]) - \phi + M \left[\text{Rg}_0(a_0 [1-jM]) + \gamma + \ln \frac{\theta_0}{\sqrt{1+M}} \right] \right\}$$

$$- \frac{2}{\pi} \left\{ \text{If}_0(a_0 [1-Mj]) + \frac{\pi}{2} \sin a_0 \right\}$$

$$+ \frac{2}{\theta_0} \left\{ 1 - e^{-b_0} (\cos a_0 + M \sin a_0) \right\} \quad (104)$$

$$\lim_{X \rightarrow 0} \xi_2 = \frac{2}{\theta_0} \left\{ e^{-b_0} (\sin a_0 - M \cos a_0) + M \right\}$$

$$- (1 + \cos a_0) \quad (105)$$

where $b_0 = a_0 M$,

$$a_0 = \frac{\theta_0}{1+M^2},$$

and $f_0(z) = \text{Rf}_0(z) + j \text{If}_0(z)$ is another co-function of the sine and cosine integrals described in Appendix A.

When $X \rightarrow 1$, there is the difficulty of $\xi_1 \rightarrow \infty$ but none with ξ_2 however. This is due to the fact that $(1 - \sqrt{X})^2$ appears in the denominator of the terms with $g_0(Z)$ in ξ_1 . There is the exception that ξ_1 is finite when $M = 0$ in this limit, however.

In order to make ξ_1 finite the collision frequency previously described must be retrieved. Since we still are assuming that $\omega_p \gg \nu$, ν need only be included in the characteristic zero k_1 . This is accomplished by the substitution and only keeping the largest term involving ν , we obtain

$$\begin{aligned}
\lim_{X \rightarrow 1} \xi_1 = & -\frac{1}{\pi \theta_0} \left\{ \gamma M - \phi + M \ln \rho_+ \operatorname{I}g_0(a_+ |1-Mj| + MRg_0(a_+[1-Mj])) \right\} \\
& - \frac{1}{2\theta_0} \left\{ 1 - e^{-b_+} (\cos a_+ + M \sin a_+) \right\} \\
& + \frac{\theta_0}{1+M^2} \left[1 - \frac{2\phi}{\pi} + \frac{M}{\pi} (3 - 2\gamma) - \frac{2M}{\pi} \ln c_1 \sqrt{1+M^2} \right]
\end{aligned} \tag{106}$$

$$\lim_{X \rightarrow 1} \xi_2 = \frac{-1}{2\theta_0} \left\{ e^{-b_+} (\sin a_+ - M \cos a_+) + M \right\} + 1 \tag{107}$$

where

$$c_1 = \frac{Y \theta_0}{1+M^2}$$

$$Y = \frac{v}{\omega \rho}$$

The first few terms in the expansion of ξ_1 and ξ_2 about $\theta_0 = 0$, in the various limits of X , are:

For arbitrary \sqrt{X} excepting $\sqrt{X} = 1$

$$\begin{aligned}
\xi_1 = & \left\{ \frac{-M25}{24 \pi} [M^4 - 10M^2 - 3] + \frac{\left(\frac{-2\phi}{\pi} + 1\right)}{12} [M^2 + 1][1 - 3M^2] \right. \\
& \left. + \frac{M(\gamma + \ln \rho_+}{6 \pi} [M^4 - 2M^2 + 5] \right\} \theta_0^3 (1 + \sqrt{X})^2 / (1 + M^2)^4 \\
& - \ln \left(\left| \frac{1 - \sqrt{X}}{1 + \sqrt{X}} \right| \right) \left\{ \frac{\theta_0 (1 + \sqrt{X})^2 M}{2\pi \sqrt{X} (1 - M^2)} + \frac{M(1 - \sqrt{X})^2 \theta_0^3}{\pi \sqrt{X} 24} \frac{[M^4 - 2M^2 + 5]}{[M^2 + 1]} \right\} + \dots
\end{aligned} \tag{108}$$

For arbitrary X excepting X = 0 and X = 1

$$\xi_2 = \frac{[1 - M^2]}{6[1 + M^2]^2} \theta_0^2 (1 + \sqrt{X})^2 + \theta_0 \left[\frac{(1 + \sqrt{X})^2}{\sqrt{X}} \right] \frac{M}{1 + M^2} U(\sqrt{X} - 1) + \dots \quad (109)$$

For X = 0

$$\xi_2 = -\frac{\theta_0 M}{(1 + M^2)} + \frac{1}{6} \theta_0^2 \frac{[1 + 2M^2]}{[1 + M^2]^2} + \dots \quad (110)$$

For X = 1

$$\xi_2 = \frac{-2}{\pi} \frac{\theta_0 M}{1 + M^2} \log \frac{Y}{2} + \frac{\theta_0^3}{\pi} \left\{ \frac{-25}{6} \frac{M[M^4 - 10M^2 - 3]}{[M^2 + 1]^4} \right. \\ \left. + \left(\frac{\pi - 2\phi}{3} \right) \frac{[1 - 3M^2]}{[1 + M^2]^3} + \frac{2\gamma}{3} M \frac{[M^4 - 2M^2 + 5]}{[M^2 + 1]^4} \right\} + \dots \quad (111)$$

$$\xi_2 = \frac{-\theta_0 M}{1 + M^2} + \frac{2}{3} \theta_0^3 \frac{[M^2 - 1]}{[1 + M^2]^3} + \dots \quad (112)$$

The plots of ξ_1 and ξ_2 versus θ_0 for various values of X, including X = 1 and X = 0, and for M = .01, .1 and 1.0 are made in Figures 5, 6, 7, 9, 10 and 11 using the relations just given. Appendix B discusses the numerical techniques used to calculate $g_0(z)$ and $f_0(z)$ for various regions in the complex plane in order to obtain these graphs. In figures 8 and 12 plots of ξ_1 and ξ_2 versus θ_0 are made for $M \rightarrow \infty$

where $M\theta_0 = \theta_0$. Before proceeding to the discussion of the graphs, the significance of the parameters M , X and θ_0 should be mentioned.

Significance of Parameters

M is the ratio of the "thermal velocity" to the drift velocity [see expression after equation (103)]. When $M \approx 0$ the effect of the drift of the plasma is dominant, and when $M \rightarrow \infty$ the "thermal effects" are dominant.

\sqrt{X} is the ratio of plasma frequency to driving frequency. The limit of $\sqrt{X} \rightarrow 0$ means that $\omega_p \ll \omega_0$. There are problems of validity of the theory in this limit and more will be said concerning this in the next chapter. When $X = 1$, that is $\omega_0 = \omega_p$, the system is at plasma resonance.

θ_0 , defined by

$$\theta_0 = \frac{2x_0 \omega_0}{u_0}, \quad (113)$$

is as much a time parameter as a space parameter. If the time it takes for a particle of velocity u_0 to traverse a distance $2x_0$, and the period of oscillation of frequency ω_0 are defined by

$$t_0 = \frac{2x_0}{u_0}$$

and

$$T_0 = \frac{2\pi}{\omega_0}$$

then the following relation results from (113)

$$t_o = \frac{\theta_o}{2\pi} T_o \quad (114)$$

Relation (114) shows that θ_o is the measure of time spent between the grids by a particle traveling with velocity u_o , similarly, θ_σ is a measure of time for a particle with velocity σ .

In order to interpret θ_o and θ_σ as space parameters, it is useful to introduce the Debye shielding length, which is an important parameter in plasma theory. The Debye length (λ_D) is a parameter which is a measure of the distance that the electric field, produced by a test charge in a conducting medium, is cancelled out by the shielding action of the other particles in the medium. λ_D can be related to the analogous thermal velocity and plasma frequency by the following equation

$$\lambda_D = \frac{\sigma}{\omega_p} \quad (115)$$

From (115) it is easy to set up the following relations

$$2x_o = \theta_o \sqrt{\frac{X}{M}} \lambda_D \quad (116)$$

$$2x_o = \theta_\sigma \sqrt{X} \lambda_D \quad (117)$$

Because λ_D is a measure of the shielding by a plasma, it is a quantity which naturally determines a division between microscopic macroscopic effects in the plasma. Macroscopic

pertains to fluid theory effects and microscopic pertains to that which can be more correctly described by kinetic theory.

The concepts just discussed will be very useful in explaining the characteristics of the graphs of ξ_1 and ξ_2 .

Description Graphs

Figures 5 to 8 show the graphs of ξ_1 (the resistive part of plasma impedance) versus θ_0 and θ_0 for various values of X and M. The figures from 5 to 8 are arranged so as to give a progression of graphs of ξ_1 from the drift dominant case to the thermal dominant case. Likewise figures 9 to 12 show graphs of ξ_2 versus θ_0 and θ_0 arranged from cases of drift to thermal dominance. The graphs of ξ_1 and ξ_2 for M = .01 figures 5 and 9 are sufficiently similar to those of M = 0.0, so that they are not reproduced here.

A most interesting observation from the graphs of the resistive part of the impedance ξ_1 is that for the drift dominant case there is a possibility of negative resistance when $X < 1$. As the value of M goes from 0 to ∞ the probability of the appearance of this negative value of ξ_1 gradually disappears. From the graphs there is no possibility of negative resistance when $M \rightarrow \infty$.

Another important fact concerning ξ_1 is that at plasma resonance ($\omega_p = \omega_0$) the resistive part of the plasma impedance would go to infinity if no collisions were included into the

calculations. The graphs of ξ_1 are plotted using a ratio of collision frequency to plasma frequency (Y) shown in and after equation (107) as 10^{-4} . This is not at all an unrealistic value.

The graphs show that the reactance of the plasma, ξ_2 , can be either inductive or capacitive. As θ_0 or θ_σ becomes very large compared to unity, ξ_2 in figures 9 and 12 asymptotically approaches the value of ξ_2 obtained from the cold non-flowing electron fluid calculation shown in (58). As can be seen, the plasma has a tendency to be capacitive when $\omega_0 > \omega_\rho$ and inductive when $\omega_0 < \omega_\rho$.

A final observation is that the wave structure of the graphs disappear as M varies from 0 to ∞ . These observations will be discussed in the next chapter along with a critical discussion of the theory.

The graphs of ξ_1 and ξ_2 which have been discussed were plotted from computation made with the IBM 7074 computer. Appendix B shows the methods used to compute $g_0(z)$ for z in different parts of the complex plane.

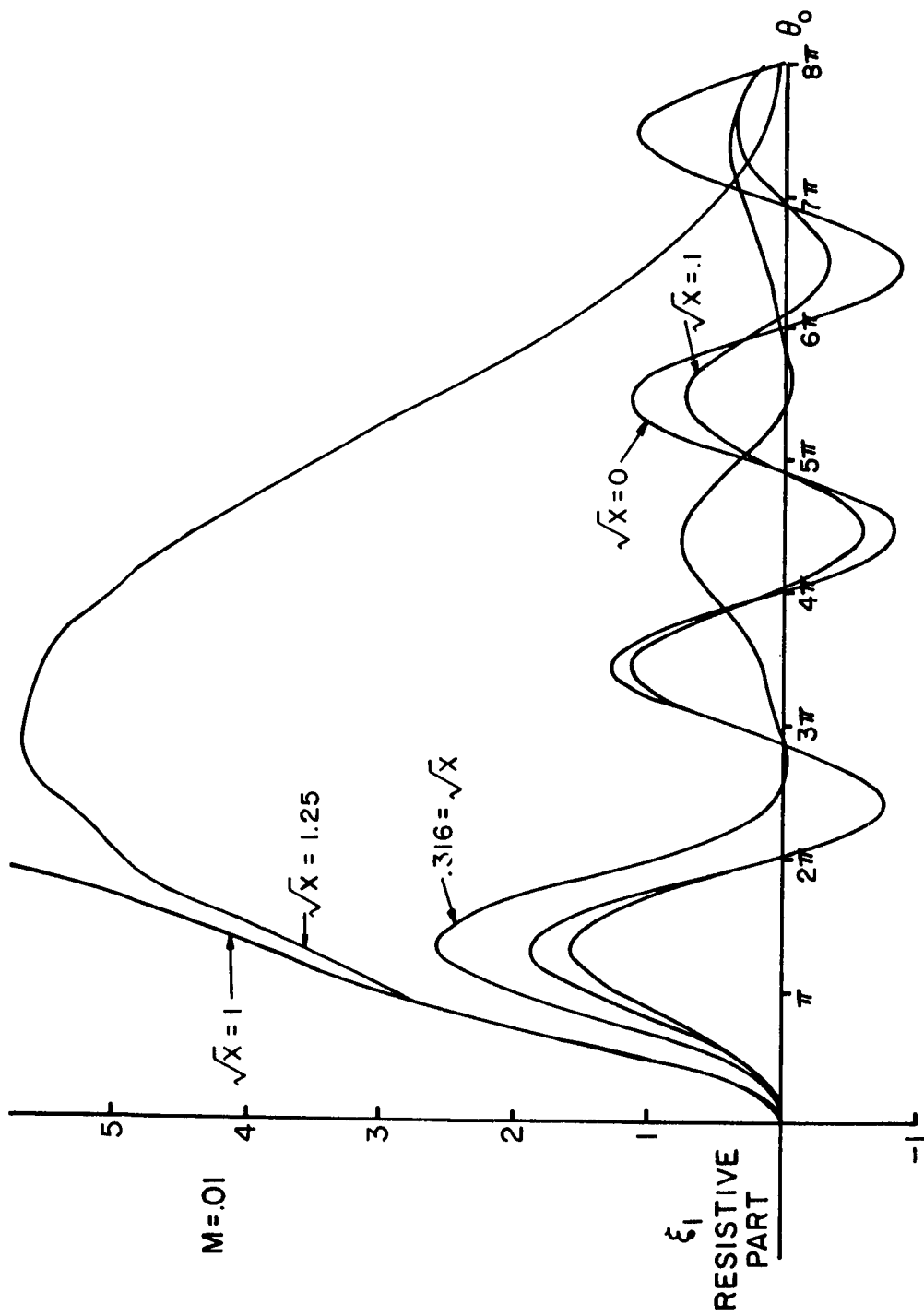

ξ_1 VERSUS θ_0 FOR $M = 0.01$

FIGURE 5

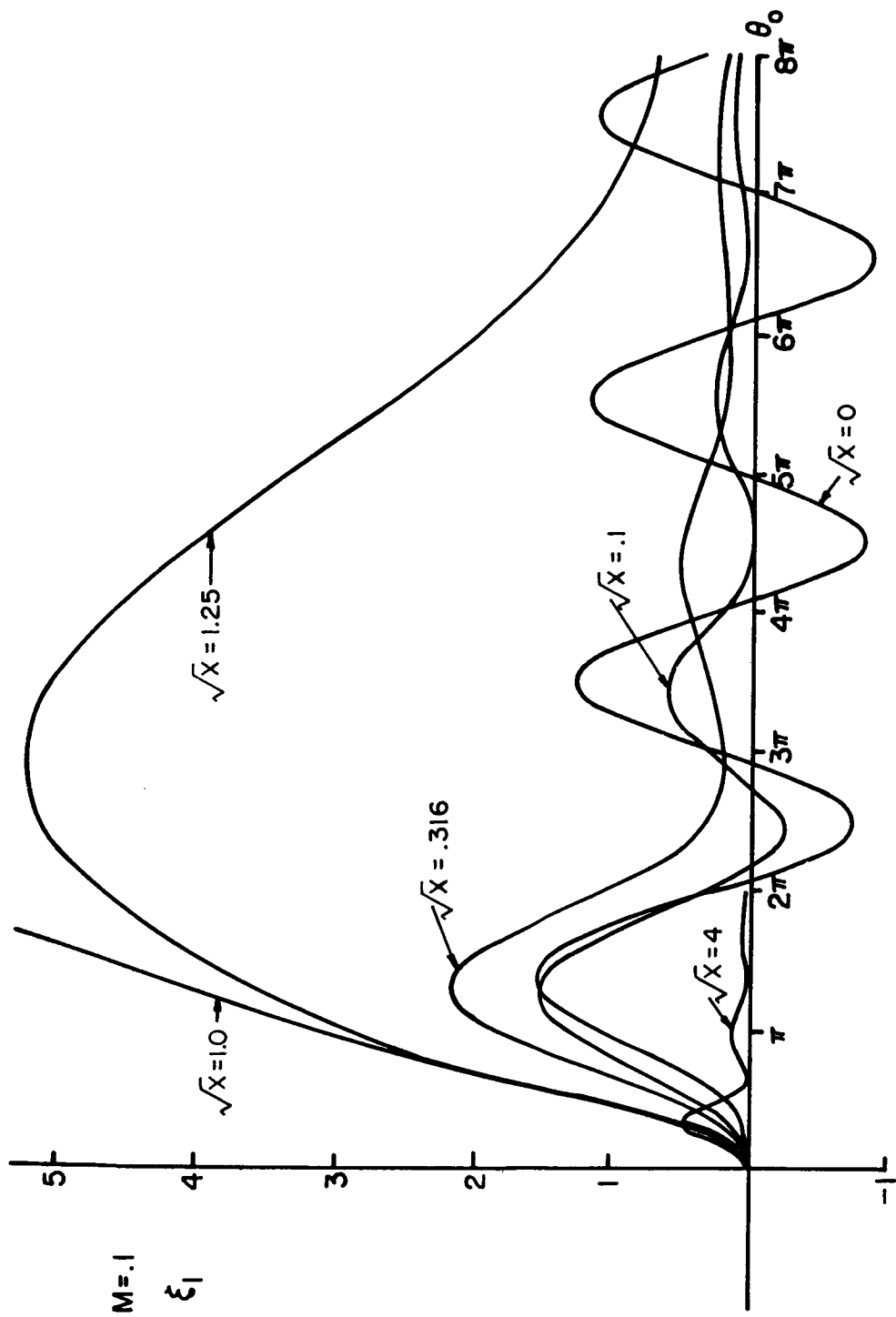

ξ_1 VERSUS θ_0 FOR $M=1$

FIGURE 6

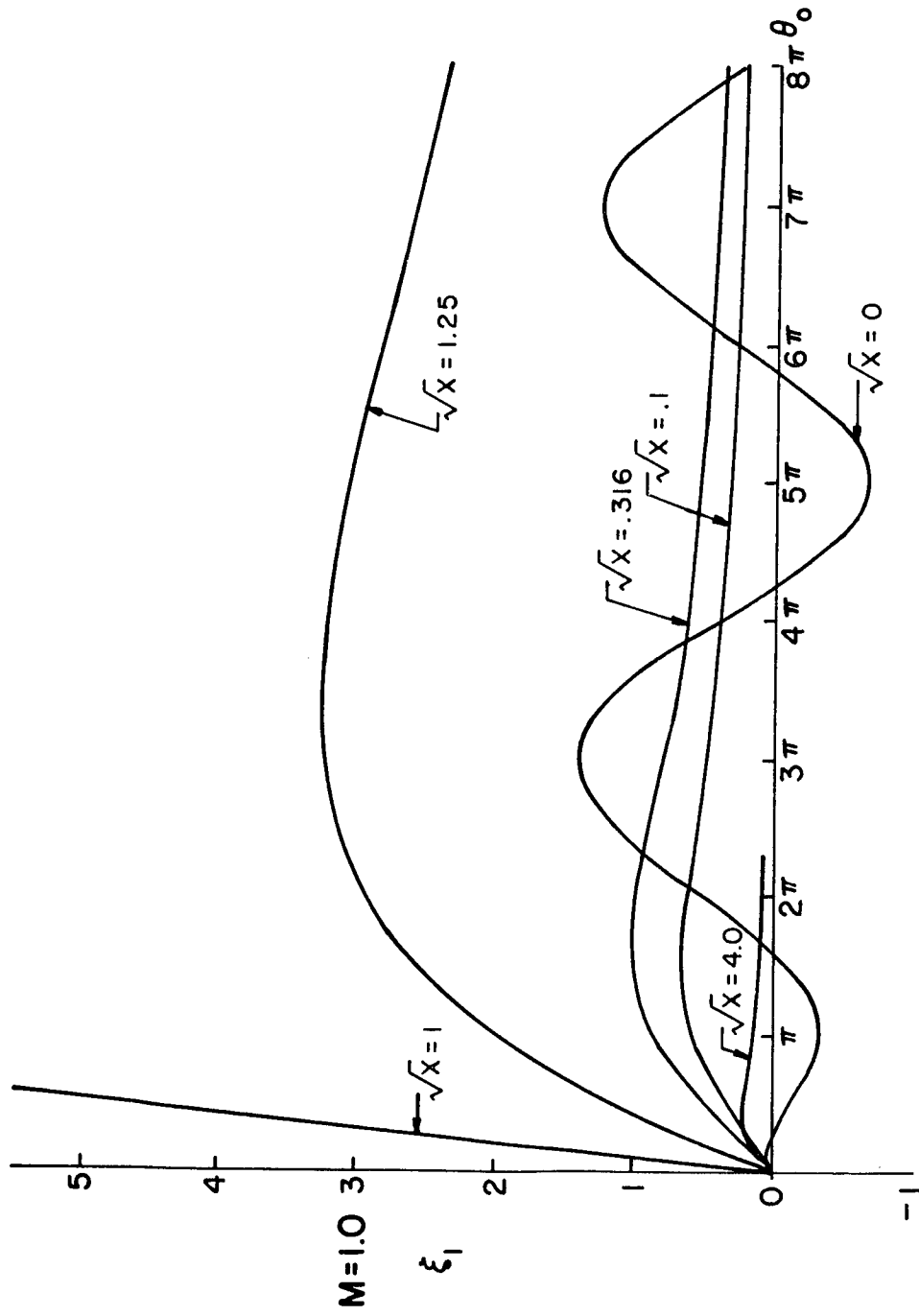

ξ_1 VERSUS θ_0 FOR $M=1.0$

FIGURE 7



 ξ_1 VERSUS θ_σ $M \rightarrow \infty$

FIGURE 8

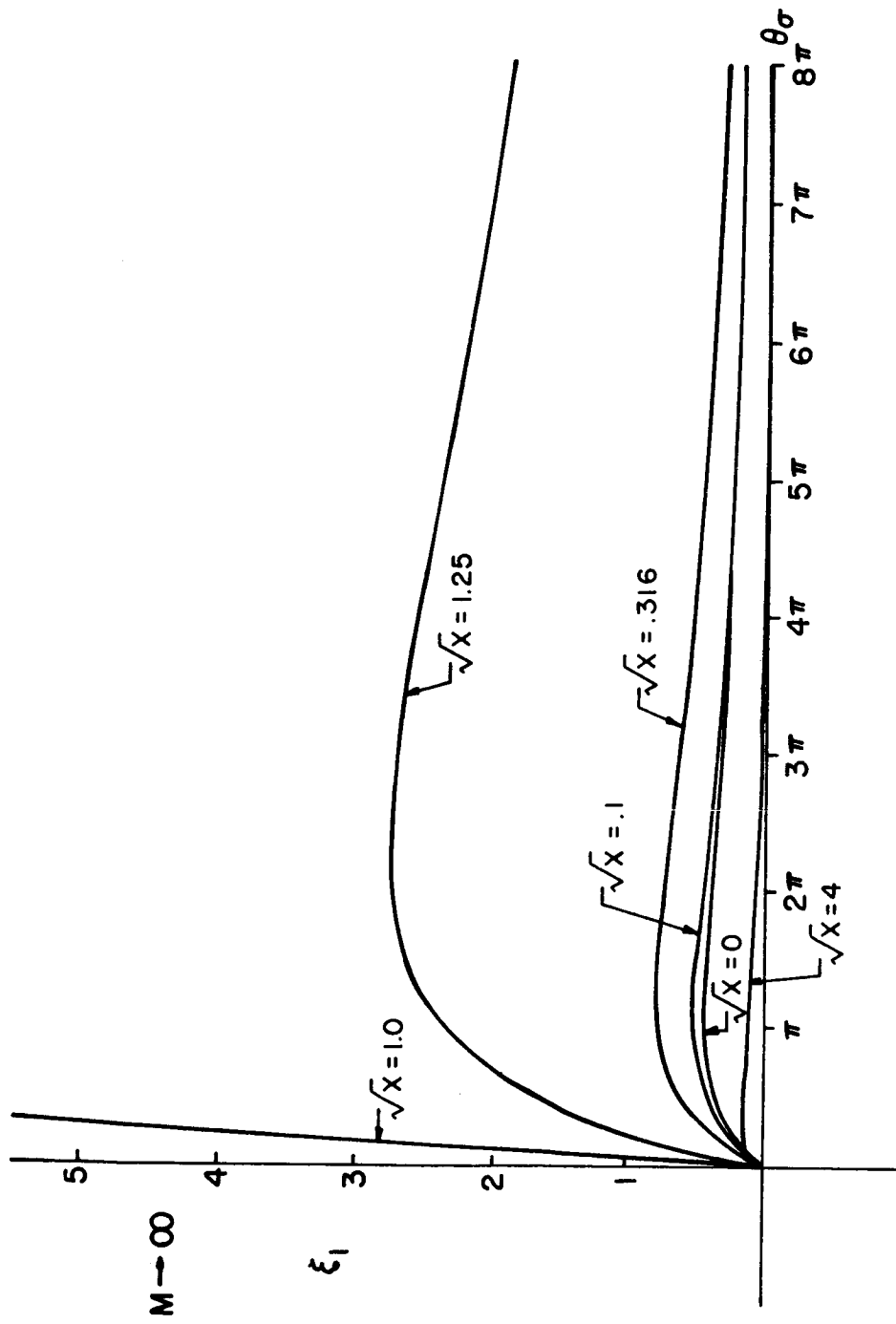
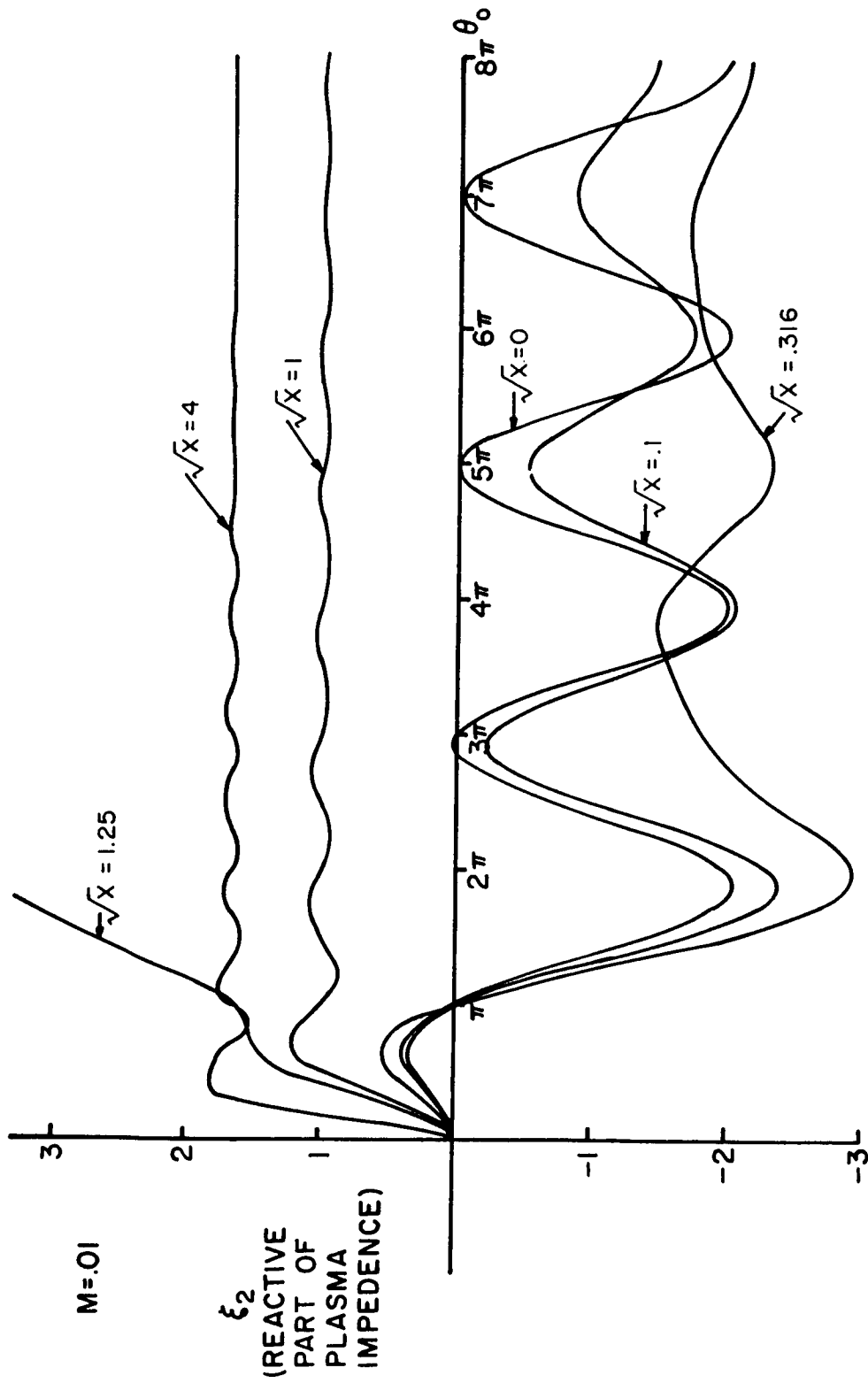
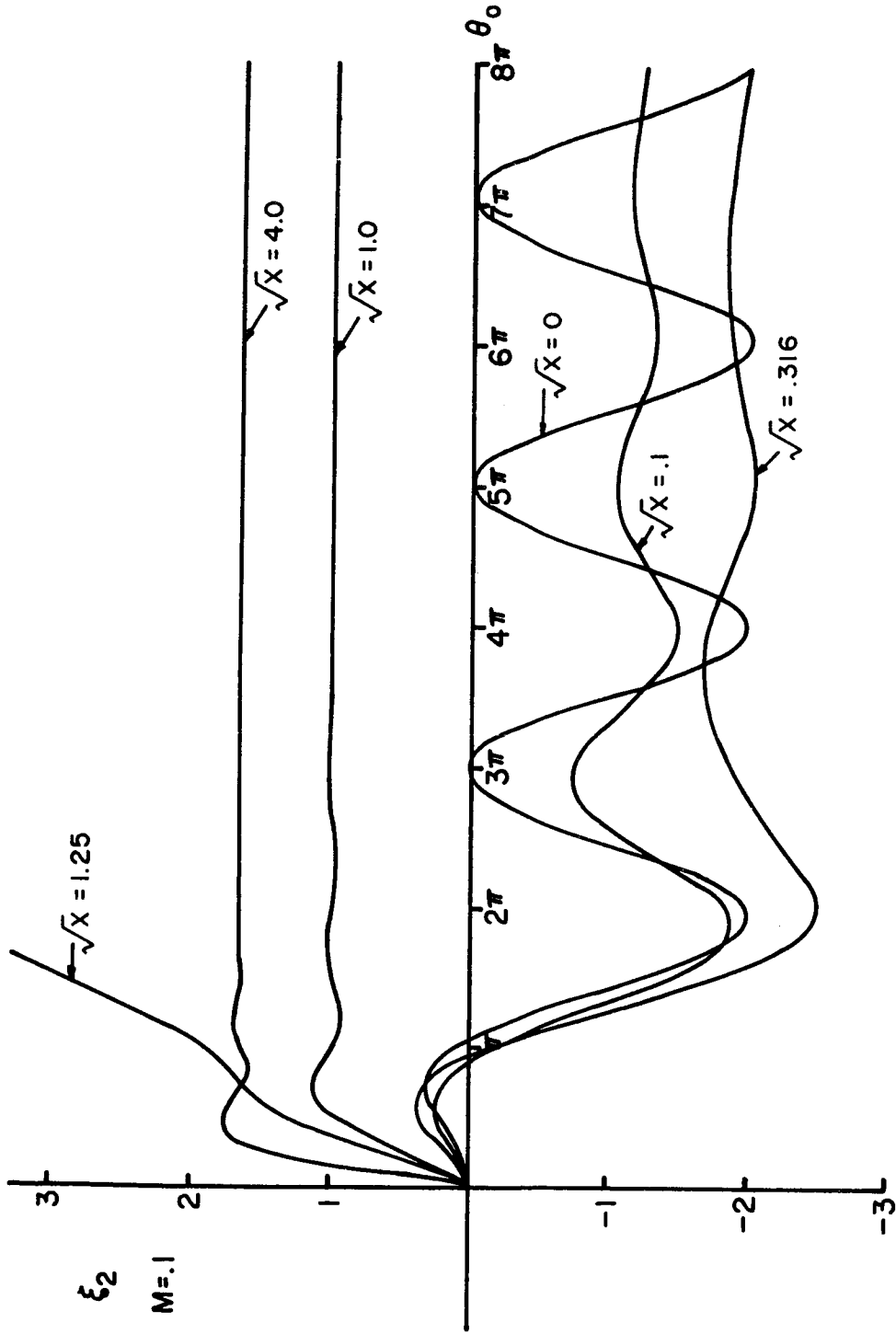

ξ_1 VERSUS θ_0 FOR $M=0.1$

FIGURE 9



ξ_2 VERSUS θ_0 FOR $M=1$

FIGURE 10

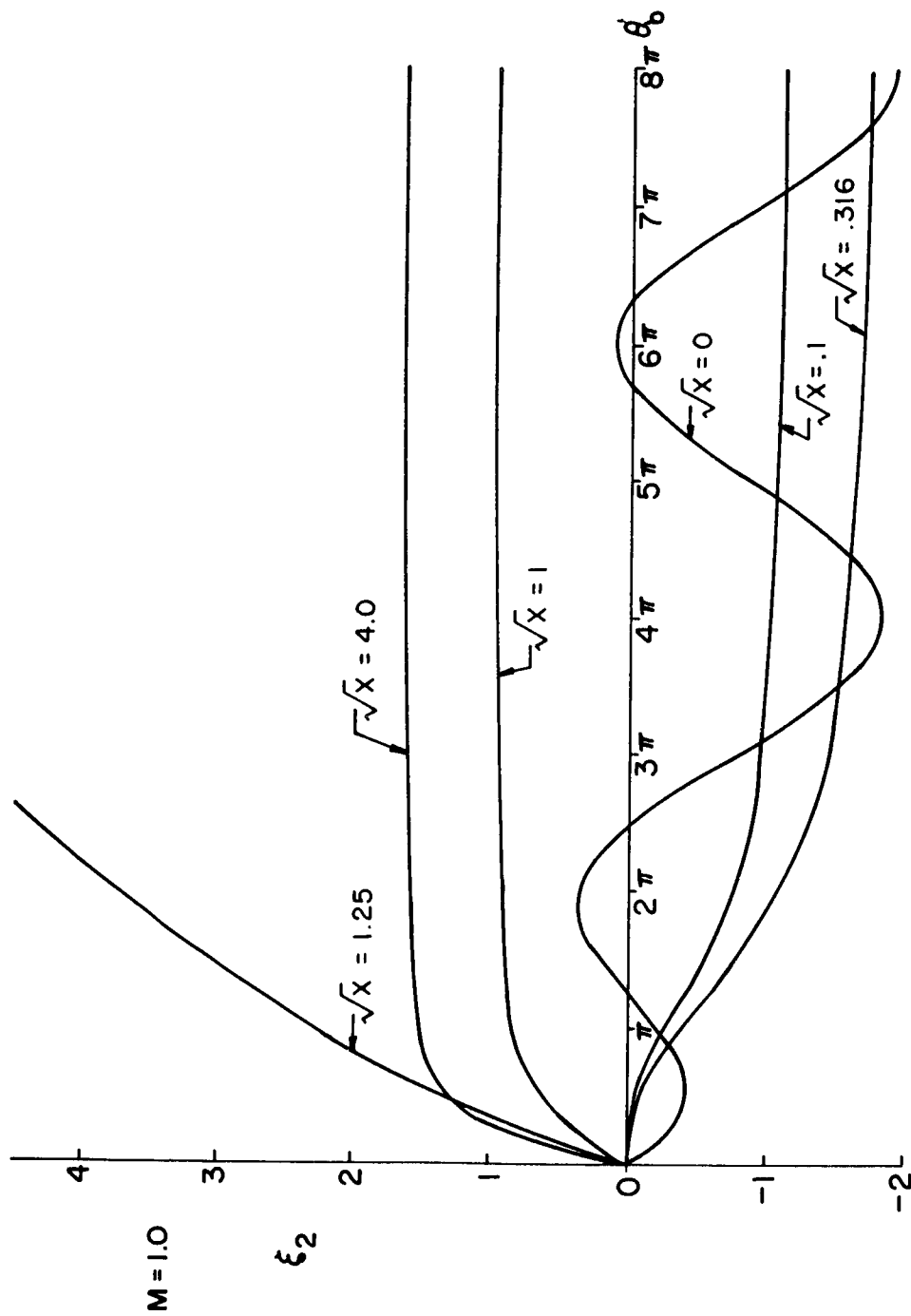

ξ_2 VERSUS θ_0 FOR $M = 1.0$

FIGURE 11

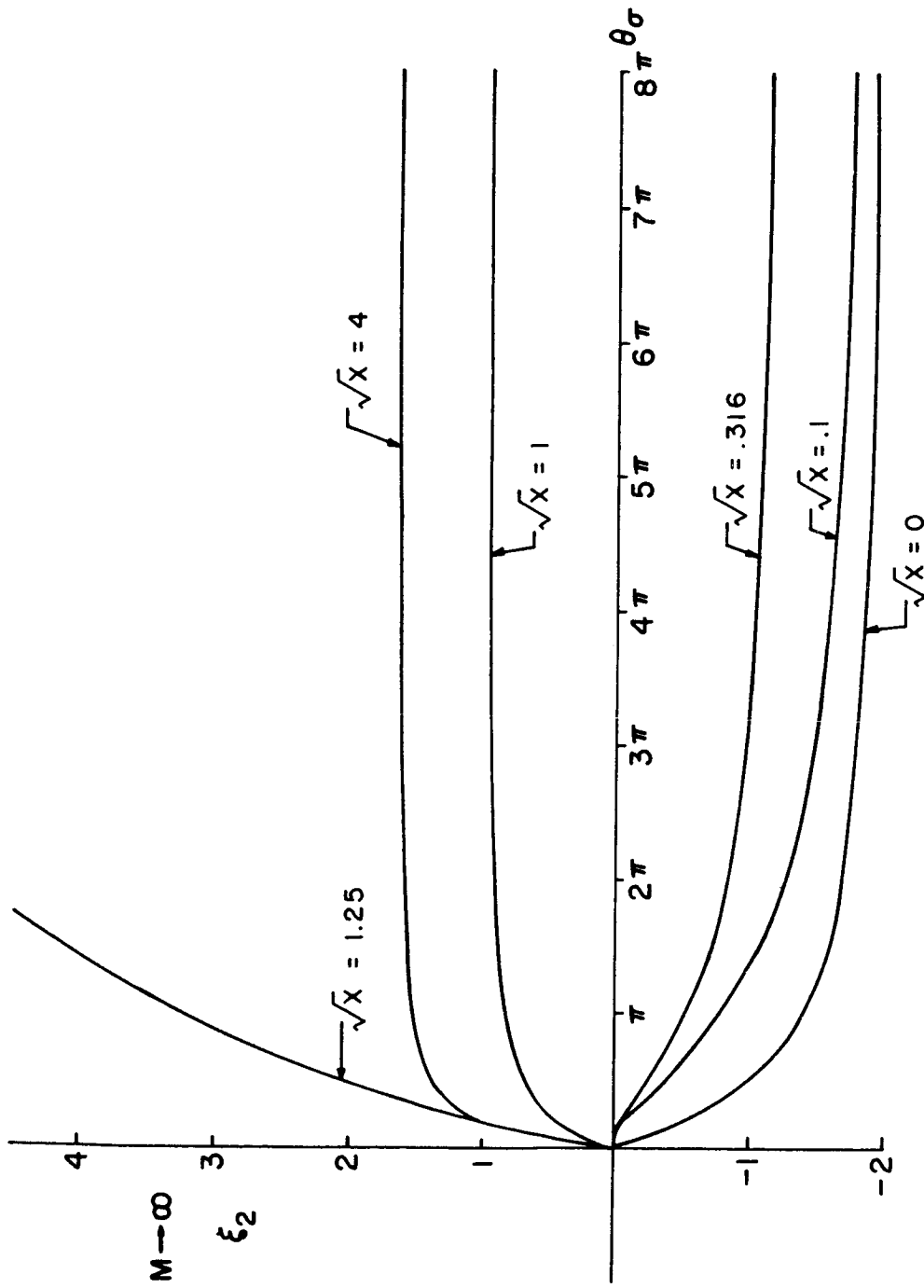

ξ_2 VERSUS $\theta\sigma$ FOR $M \rightarrow \infty$

FIGURE 12

IV. Discussion

Introduction

This chapter includes discussions on three basic areas of the theoretical research. The first consists of giving an explanation of the observations made of the impedance graphs. The second consists of giving an analysis of the limitation of the applicability of the physical theory. The third consists of comparing and contrasting this theoretical work with that done by other investigators.

Discussion of the Graphs

The most interesting characteristic of the resistive graphs is the possibility of negative resistance when $X < 1$. The fact that this negative resistance gradually disappears as M goes from 0 to ∞ indicates that this is a drift related phenomenon. A negative resistance means that energy is being transferred from the plasma to the external circuit; a positive resistance means a flow of energy in the reverse direction.

Two questions one could well ask are: "What is the mechanism of energy loss in the plasma?" and "What is the source in the plasma of the energy that the external circuit absorbs?" The clue to the answer of both these questions is in the observation that negative resistance can exist when

there are drifts. In fact this negative resistance occurs when there is no thermal energy, as in Rydbeck's problem. The only energy source available is the drift kinetic energy of the plasma. Then the energy absorbed from the plasma must be due to the net deceleration of the plasma. Similarly one of the principle mechanisms in the drift dominant case for energy absorption from the external circuit must be a net acceleration of the drift kinetic velocity of the plasma.

The principle mechanisms for energy absorption for a thermal-dominated plasma $M \rightarrow \infty$ would be Landau damping and the transport of energy due to particle diffusion from inside to outside of the region between the grids. Landau in 1946, following Vlasov, showed that it was possible to have damping of plasma waves in a plasma even if the collision frequency ν in equation (61) was zero. Some people have therefore spoken of this phenomenon as collisionless damping. This is not accurate terminology however. True, short range or close collisions are neglected when we set $\nu = 0$, but the average long-range collisions effect, that is, the Electric field, is still present. It is these long range "collisions" that are the cause of the plasma oscillations. In the next section a study of the energetics of the plasma is done to show the transport of energy to and from the region between the grids.

Another interesting phenomenon concerning ξ_1 occurs at plasma resonance ($X = 1$). It seems strange that introducing collisions into the system decreases the resistance at plasma "resonance". This fact can be understood better if we realize that we are speaking of a process which is assumed not to be collision dominated and that "resonance" as understood in this plasma effect is different from the normal use of the term. In the normal use of the term, resonance means that condition of the system where the power absorption of the system from a particular forced oscillator is a maximum. This maximum occurs for a certain driving frequency of the oscillation.

In an actual experimental situation the force put on the system would be the electrical potential put across the grids. In this situation the time average power absorbed by the plasma would be given by

$$P_o = \frac{1}{2} \frac{|\Delta\phi|^2 R(\omega_o)}{R^2(\omega_o) + \chi^2(\omega_o)} \quad (118)$$

where $Z(\omega_o) = R(\omega_o) + j\chi(\omega_o)$. Equation (118) shows that the power goes to zero as $R(\omega_o) \rightarrow \infty$ when $\omega_p = \omega_o$. Therefore plasma resonance produces a minimum instead of a maximum power transfer. The resistance going to infinity for a particular oscillating potential also means that the external current goes to zero. This can be thought of as an open

circuit. What is actually happening at this plasma "resonance" is that for a collisionless plasma the charges can move fast enough to set up a potential difference across the grids, without the flow of a current in the external circuit. When collisions are included, they impede the motions of the electrons and, thereby allowing currents to flow in the external circuit and thereby effectively decreasing the resistance of the plasma.

The plasma reactance ξ_2 behaves like the well known result presented by equation (58) as θ_0 and θ_σ goes to ∞ . Of course equation (58) has a singularity at $\omega_0 = \omega_p$ and one cannot determine the impedance there from the simple fluid theory leading to (58). If one includes collisions in the calculation of the impedance and first takes the limit as $\omega_0 \rightarrow \omega_p$ and secondly takes the limit as $\nu \rightarrow 0$, then $\xi_1 \rightarrow \infty$ and $\xi_2 \rightarrow 1.0$ which are the same limits our results have for $\omega_0 = \omega_p$ when θ_σ and $\theta_0 \rightarrow \infty$.

Another observation which was made concerned the disappearance of wave structure in the graphs as M varied from 0 to ∞ . This fact points up the different nature of the plasma in the two limits of drift dominance and thermal dominance. When the plasma is drift dominant ($M \rightarrow 0$), the plasma has a wave nature. When $M = 0$, the solution of the electric field can actually be written as a superposition of two traveling waves of the form

$$E_{\pm} e^{j(\omega_0 t - \frac{\omega_0 + \omega_p}{u_0} x)}$$

These waves have a group velocity of u_0 whose wave fronts travel away from the grids in the direction of the flow of the plasma. Even when the phase velocity of one of the waves becomes negative, when $\omega_0 < \omega_p$, the group velocity still remains positive and the disturbance propagates away from the grids only in the direction of the flow. There is no disturbance in the plasma on the left side of the grids in this drift dominant limit. In simple terms the motion of the plasma through the grids carries the plasma oscillations away from the grids. In a zero temperature plasma there cannot be propagation of a disturbance due to longitudinal waves unless the plasma is moving.

In contradistinction to the drift dominant case, the disturbance in a thermally dominant plasma cannot in general be written in terms of a simple superposition of traveling waves. In the thermally dominant case, the plasma has diffusion associated with it. In fact one can consider the electric field as diffusing¹³ instead of propagating as waves through the medium.

Energetics

This section will show that the time average power fed into the plasma by the external circuit equals the time average energy flux across the surfaces bounding the region between

the girds. In order to show this to be true we need an equation to describe the energy conservation in the system. This equation can be obtained by calculating the second moment of the Vlasov-Boltzmann equation (14), that is, multiplying equation (14) by v^2 and then integrating over all \vec{v} -space. This produces the following energy equation

$$\begin{aligned} \frac{\partial}{\partial t} \left(n \left\langle \frac{1}{2} m v^2 \right\rangle \right) + \frac{\partial}{\partial \vec{x}} \left(n \left\langle \frac{1}{2} m v^2 \vec{v} \right\rangle \right) \\ = \vec{J} \cdot \vec{E} \end{aligned} \quad (119)$$

The current \vec{J} and electric field \vec{E} are those which are produced in the plasma itself. If we take the dot product of \vec{E} with equation (48) where $\vec{E} = -\nabla\phi$ we get

$$\frac{\epsilon_0}{2} \frac{\partial E^2}{\partial t} + \vec{E} \cdot \vec{J} = \vec{E} \cdot \vec{J}_{\text{ext}} \quad (120)$$

where $\vec{J}_{\text{ext}} = I_0 \hat{i} \cos \omega_0 t [U(x + x_0) - U(x - x_0)]$.

Combining (118) and (117) we obtain

$$\frac{\partial}{\partial t} \left[\frac{E^2}{2\epsilon_0} + n \left\langle \frac{1}{2} m v^2 \right\rangle \right] + \frac{\partial}{\partial \vec{x}} \left[n \frac{1}{2} \left\langle m v^2 \vec{v} \right\rangle \right] = \vec{E} \cdot \vec{J}_{\text{ext}} \quad (121)$$

The time average of (119) for a steady state periodic oscillation gives zero for the time derivative term. If we write \vec{J}_{ext} and \vec{E} in their complex time dependent forms the time average of (121) becomes

$$\overline{\frac{\partial}{\partial x} \left(n \left\langle \frac{1}{2} m v^2 \vec{v} \right\rangle \right)} = \frac{1}{2} \text{Re} [\vec{E} \cdot \vec{J}_{\text{ext}}^*] \quad (122)$$

where the bar denotes time average.

In order to obtain the expression we want, we must integrate (122) over the region of space between the grids bounded by the grids with some cross sectional area A. This gives us

$$\int_s \overline{n \left\langle \frac{1}{2} m v^2 \vec{v} \right\rangle \cdot d\vec{s}} = \frac{A}{2} \text{Re} \left\{ J_{\text{ext}}^* \cdot \hat{i} \int_{-x_0}^{x_0} E_x dx \right\} \quad (123)$$

where s represents the surface surrounding the volume. But

$$\int_{-x_0}^{x_0} E_x dx = \Delta\phi = I_0 e^{j\omega_0 t} Z(\omega_0) \quad (124)$$

Therefore

$$\frac{1}{A} \int_s \overline{n \left\langle \frac{1}{2} m v^2 \vec{v} \right\rangle \cdot d\vec{S}} = \frac{I_0^2}{2} R(\omega_0) \quad (125)$$

Equation (125) is the statement made in the beginning of this section. The left side of (123) is the energy loss rate per unit area due to energy flux across the grids. The right side is the power fed into the grids by the external circuit. Equation (125) helps make negative resistance more plausible.

Negative resistance means that there is a net time average energy flux into the volume bound by the grids.

Limitation to the Applicability of the Theory

In introducing the influence of the external circuit on the plasma, we included the influence of the current in our equations but neglected the effects the magnetic field produced by this current. In essence we neglected the magnetic compared to the electric field effect of the external circuit. In order to see what limitations this assumption puts upon the applicability of the theory, we must look at a finite electrical system since the magnitude of the magnetic field in this situation depends upon the dimensions of the system. For purposes of discussion, we will consider that the system consists of a cylindrically shaped plasma passing through two parallel disc grids where the radius of the discs and the cylindrical plasma are both R_0 . Figure 13 shows a sketch of the finite system and the cross section of the cylindrical plasma between the grids. Since it is assumed that the total current is homogeneously distributed over the cross section of the plasma, the maximum magnetic field exists at the boundary of the plasma and has a magnitude given by

$$B(R_0) = \frac{R_0 \mu_0}{2} I_0 \quad (126)$$

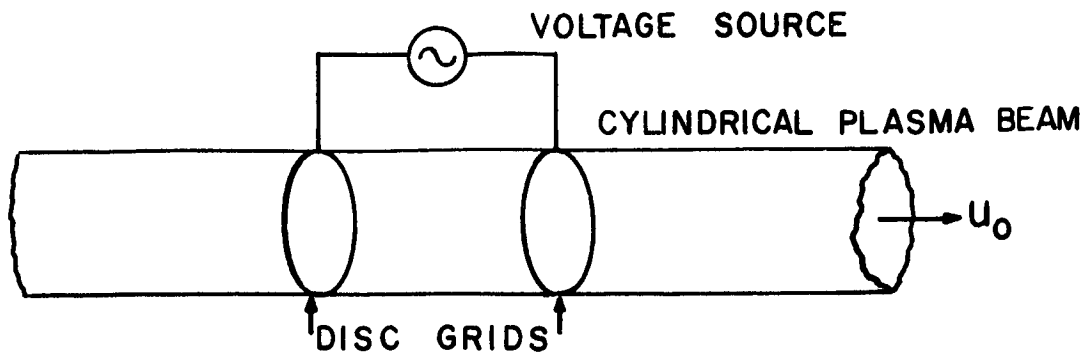

DISC GRIDS IN CYLINDRICAL PLASMA BEAM

FIGURE 13.a

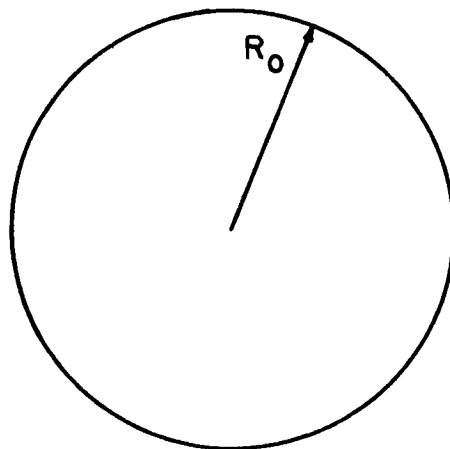

CIRCULAR CROSS SECTION OF PLASMA BEAM
WITH RADIUS R_0

FIGURE 13.b

The magnitude of the electric field produced by uniform charge densities produced on the grids by the external circuit is given by

$$E = \frac{I_0}{\omega_0 \epsilon_0} \quad (127)$$

The ratio of the force produced by the magnetic field to the force produced by the electric field on the charges of the medium must be very small in order to be able to neglect the magnetic effects. This statement can be expressed by

$$\frac{v_c B}{E} \ll 1.0 \quad (128)$$

where v_c is a characteristic velocity of the plasma -- either σ or u_0 depending on whether the plasma is drift or thermal dominant. Inserting (126) and (127) into (128) yields the condition

$$\omega_0 v_c R_0 \ll 2c^2 \quad (129)$$

where c is the speed of light in free space. Another condition which must be met is that the radius of the grids must be much larger than the separation of the grids in order to neglect fringing field effects or

$$R_0 \gg 2x_0 \quad (130)$$

Using the definition of θ_0 in (113) we can combine conditions (129) and (130) to give the condition

$$\theta_0 \ll \frac{2c^2}{v_c u_0} \quad (131)$$

which is the condition which should be easily satisfied for the non-relativistic plasma that we have. (131) should not be considered as replacing condition (129) and (130) however. It is produced so as to show that the conditions called for are not at all unrealistic. The conditions just developed should be considered a sufficient condition for the applicability of the theory. The theory may be valid outside the ranges given.

Results Related to Those Obtained by Others

This thesis contains a method which extends plasma kinetic theory boundary value problems to include problems which deal with the drift motion of the plasma. We will compare our results with those obtained by Landau¹, Shure⁵, and Cercighani and Pagani¹⁸ who do not take drifts into account. In the kinetic theory of plasmas treated by these men, an important role is played by the function $K(\omega, k)$ given by (71) which has been alternatively called the dielectric function, the dispersion function and the characteristic function. Since the works of Shure and Landau illustrate the two different approaches to plasma boundary value problems -- the normal mode and transform method

we will show the connection between our subsidiary function $K_{\pm}(\omega, k, u)$ and the corresponding functions defined by these people. If we make $F_0(v)$ in (71) the Maxwell-Boltzmann distribution as Landau and Shure did, then $K_{\pm}(\omega, k, u)$ can be related to Landau's $K_1(k)$ and $K_2(k)$ and Shure's $\Lambda^{\pm}(v)$ by the following equations

$$K_{\pm}(\omega, k, 0) = 1 - K_1(k) = \Lambda^{\pm}\left(\frac{\omega}{k v_1}\right) \quad (132)$$

where $v_1 = \sqrt{\frac{k_0 T}{m}}$, $T =$ absolute temperature, $k_0 =$ Boltzmann's constant, and $m =$ mass of the electron.

We know of no work outside of this thesis that deals with the impedance of a grid pair in an infinite plasma using kinetic theory even without the inclusion of a drift effect. However, Shure⁵, and Cercignani and Pagani¹⁸ do consider the problem of a plasma between infinite capacitor plates.

Shure considers the capacitor plates to be perfectly reflecting walls and therefore does not permit the plasma to diffuse through. His results show the existence of Landau damping at certain resonant frequencies and that the impedance reduces to the stationary cold plasma case (57) as ours does when the distance between the plates becomes very large. However the electric field in Shure's problem can always be written as a superposition of traveling waves unlike ours which cannot. We have attributed these additional terms to the effects of the diffusion of the plasma through the grids.

Cercignani and Pagani take collisions into account and consider the plasma capacitor with two different types of boundary conditions upon the velocity distribution function. The first boundary conditions was the same as in Shure's problem, and the second assumed that the electrons diffused through the walls with a Maxwellian distribution. Their results reduces to Shure's when the collision frequency was made to go to zero for the first boundary condition. For the second boundary condition, their results again reduced to (57) as the distance between the plates became much larger than the Debye length.

V: Summary and Conclusions

Statement of the Problem

This thesis dealt with two related problems called the theoretical and physical problems. The theoretical problem consisted of finding a mathematical method for the solution of a class of one dimensional kinetic theory problems, in particular a class of problems which take plasma flows into account. The physical problem, which consisted of finding the impedance of a grid pair in a flowing plasma, is a particular situation to which the above mathematical method may be applied and served as a motivation to develop the method.

Rydbeck³ obtained the impedance of a grid pair in a flowing plasma using the cold electron fluid theory of a plasma. His results showed that it was possible for the impedance to have a negative resistive part. These results motivated us to find out whether it was possible to predict negative resistance if thermal effects were taken into consideration.

Method Used

In order to include thermal effects into the calculation, the kinetic theory of plasmas (Landau-Vlasov theory) was used. No thorough investigation had been made of how the inclusion of an average flow velocity would effect the dispersion

function (71) in that theory and therefore the general characteristics of the solution of such problems in the kinetic theory of plasmas. This lack motivated us to develop the mathematical method for such problems which could be applied to our physical problem.

The linearized Vlasov equation coupled with the Poisson's equation were used to solve the problem. The drift or plasma flow was included as the mean velocity of the zero order electron distribution function. The boundary conditions produced by the grids on the plasma were included into the differential equations by using generalized functions. The differential equations were then solved for the potential difference across the grids using Fourier-Laplace transforms.

In order to obtain the gross features of the impedance, a simple Lorentzian distribution was used. Graphs were then plotted of the resistive and capacitive parts of the plasma impedance as a function of a space parameter (or time parameter depending on the viewpoint) for various values of the ratio of plasma to driving frequency and various values of the ratio of the width of the Lorentzian distribution to the flow velocity. (This width is considered analogous to the Maxwell-Boltzmann distribution.)

Results and Conclusions

The results, like the problems, can be divided into two groups -- the first set of results dealing with the graphs and the solution to the physical problem and the second set dealing with the basic theoretical results comparing the behavior of a flowing plasma to that of a stationary plasma.

The graphs show that it is still possible to have negative resistance when thermal effects are added to the calculation of the impedance of a grid pair in a plasma. It also appears that this negative resistance is a drift dominant effect caused by a net deceleration of the plasma flow for a certain combination of parameters of the system. There is no possibility for negative resistance when there is no drift however.

Two important theoretical results are those that are obtained by Theorems II and III in Appendix D. Shure⁴ showed in his thesis that the characteristic zero k_1 of the function $K(\omega, k)$ which lies on the imaginary axis for $X > 1$ (Theorem II) accounts for the fact of a dynamic Debye shielding of an electrical disturbance in the plasma. The existence of the zero on the imaginary axis is necessary for dynamic Debye shielding. If the zero moves off this axis, the electric field is no longer shielded by the plasma but the disturbance produced by it propagates in the direction of the flow of the plasma. One should probably expect

some remnants of Debye shielding to remain, however, if the flow velocity of the plasma were less than the thermal velocity. This shielding would probably be modified and one would expect an anisotropic shielding to exist in the direction of the flow of the plasma. As the flow velocity gets larger than the thermal velocity all remnants of shielding eventually disappear and pure wave propagation exists as is shown in the cold electron fluid theory.

A further result shows a connection between the slow and fast waves of the cold electron fluid theory and the characteristic zero k_1 . The waves excited by a driving frequency ω_0 have the following wave numbers

$$k = \frac{\omega_0 \pm \omega_p}{u_0}$$

The plus and minus in the above expression refer to what are called the slow and fast waves respectively. For $\omega_p > \omega_0$ the wave number of the fast wave lies on the negative real axis. When the drift velocity $u_0 > 0$ the characteristic zero k_1 moves into the complex plane left of the axis of reals. As u_0 becomes much larger than σ (the width of the zero order electron distribution), k_1 migrates onto the negative real axis and becomes the fast wave. This then leads to the conclusion that it is the fast wave which is associated with Debye shielding.

Suggestions for Further Research

The results presented in this thesis in no way represent the final words on the problem under consideration. Here are some suggestions as to further work related to this thesis which could be done.

A more accurate theory to solve the impedance problem would require a relativistic kinetic theory and also would have to take into account the finite boundaries of the system. There have already been some attempts to include these considerations in various kinetic theory plasma problems, but, the surface has barely been scratched^{20,21}.

Also collision terms which are more physically realistic, that is, which conserve particles, momentum or energy such as the Crook and Folker Plank collision models could also be included so as to give a better study into the effects of the collisions upon the resistive part of the plasma impedance.

The method of including the grids into the differential equations could be used to analyze the properties of a multigrid system in a plasma. A complete analysis of any one system of grids in a plasma by the kinetic theory of plasmas should prove to be a thesis problem in itself.

Some work has been done, notably by Gould¹⁹, on predicting the propagation of disturbances away from a

grid pair in a stationary plasma using kinetic theory. Gould did not consider the problem of coupling the grid pair to the plasma. Gould's problem could now be redone in the light of this thesis. His problem could also be extended to include the effects of the drifting plasma.

Appendix A: Special Functions and Partial Fraction Expansion

Auxiliary Functions

Two important functions used in this thesis are the auxiliary functions of the sine and cosine integrals. They are defined by

$$f_0(z) = \text{Ci}(z) \sin(z) - \text{si}(z) \cos(z) \quad (\text{A.1})$$

$$g_0(z) = -\text{Ci}(z) \cos(z) - \text{si}(z) \sin(z) \quad (\text{A.2})$$

where $z = x + jy$ and

$$\text{Ci}(z) = \gamma + \ln z + \int_0^z \frac{\cos(t) - 1}{t} dt \quad (|\arg z| < \pi) \quad (\text{A.3})$$

$$\text{Si}(z) = \int_0^z \frac{\sin(t)}{t} dt \quad (\text{A.4})$$

$$\text{si}(z) = \text{Si}(z) - \pi/2 \quad (\text{A.5})$$

Other representations of $f_0(z)$ and $g_0(z)$ are

$$f_0(z) = \int_0^\infty \frac{\sin(t)}{t+z} dt = \int_0^\infty \frac{e^{-zt}}{t^2+1} dt, \quad (|\arg z| < \pi/2) \quad (\text{A.6})$$

$$g_0(z) = \int_0^\infty \frac{\cos(t)}{t+z} dt = \int_0^\infty \frac{te^{-zt}}{t^2+1} dt, \quad (|\arg z| < \pi/2) \quad (\text{A.7})$$

$f_0(z)$ and $g_0(z)$ can also be related to the exponential integral $E_1(z)$ by

$$g_0(z) = 1/2 [e^{jz} E_1(jz) + e^{-jz} E_1(-jz)] \quad (\text{A.8})$$

$$f_0(z) = 1/2 [e^{jz} E_1(jz) - e^{-jz} E_1(-jz)] \quad (\text{A.9})$$

where $|\arg z| < \pi/2$

$$\text{and } E_1(z) = \int_z^\infty \frac{e^{-t}}{t} dt \quad (\text{A.10})$$

An important relation which we have not seen in any book but which can be derived using the above relationships and more extensive list of relations in the "Handbook of Mathematical Functions" edited by Abramowitz and Stegun, are

$$\lim_{\delta \rightarrow +0} g_0(\pm\delta - jy) = -\cosh(y) \text{Chi}(y) + \sinh(y) \text{Shi}(y) \pm \frac{\pi}{2} j e^{-y} \quad (\text{A.11})$$

$$\lim_{\delta \rightarrow +0} f_0(\pm\delta - jy) = j [\cosh(y) \text{Shi}(y) - \sinh(y) \text{Chi}(y)] \pm \frac{\pi}{2} e^{-y} \quad (\text{A.12})$$

where $\cosh(z)$ and $\sinh(z)$ are the hyperbolic cosine and sine respectively, and

$$j \text{Shi}(z) = \text{Si}(jz), \quad (\text{A.13})$$

$$\text{and } \text{Chi}(z) = \gamma + \ln(z) + \int_0^z \frac{\cosh(t) - 1}{t} dt. \quad (\text{A.14})$$

It is important to notice that, while $\text{Si}(z)$ and $\text{Shi}(z)$ are entire functions in the complex z -plane, $\text{Ci}(z)$ and $\text{Chi}(z)$

have a cut starting at the branch point at $z = 0$ and continuing down the negative real z -axis to $-\infty$. (A.1)

and (A.2) point up the fact that $f_0(z)$ and $g_0(z)$ also have this cut.

To conclude with these functions, we give the differential formulas for relating $g_0(z)$ and $f_0(z)$. They are

$$\frac{df_0}{dz} = -g_0(z) \quad (\text{A.14})$$

and

$$\frac{dg_0}{dz} = \frac{-1}{z} + f_0(z) \quad (\text{A.15})$$

Partial Fraction Expansion

Modified partial fraction expansions (equations (86) and (87)) were made in Chapter II in order to simplify the calculations. This section shows how this type of an expression is equivalent to the normal partial fraction expansion which can be made.

If $K + (\omega_0, k, u_0)$ is an analytic function which has N zeroes k_i of order one, the Mittag-Leffler partial fraction expansion theorem says that the following partial fraction expansion may be made

$$\frac{1}{k^2 K_+(\omega_0, k, u_0)} = \frac{A_0}{k^2} + \frac{A_1}{k} + \sum_{k=2}^{N+1} \frac{A_i}{k - k_i} \quad (\text{A.16})$$

If we multiply (A.16) by k and then take the limit as $k \rightarrow \infty$

we obtain

$$A_1 = - \sum_{k=2}^{N+1} A_i \quad (\text{A.17})$$

since $K_+(\omega, k, u_0) \rightarrow 1$ as $k \rightarrow \infty$

We can now replace the sum in (A.17) for A_1 in (A.16)

and add to get

$$\frac{1}{k^2 K_+(\omega_0, k, u_0)} = \frac{A_0}{k^2} + \sum_{k=2}^{N+1} \frac{k_i A_i}{k(k-k_i)}$$

which is the modified expansion we used.

Appendix B: Methods of Computation

In order to obtain the graphs of ξ_1 and ξ_2 computer calculations were made for various values of X and M shown and at intervals of $(.1)\pi$ for θ_0 and θ_σ . There already existed computer routines to calculate $\sin(x)$, $\cos(x)$, $\exp(x)$ and $\log(x)$ but none to calculate $Ci(xz)$, $Si(z)$ or $E_1(z)$ ($z = x + jy$) for complex argument so that programs had to be developed to do these calculations. The following sections explain the methods of calculation for various ranges of x and y.

$$\underline{100 > |z| > 10 \text{ and } |\arg z| \leq \pi/4}$$

For this range of values the following approximate expression was used with (A.8) and (A.9) in order to obtain $f_0(z)$ and $g_0(z)$

$$e^z E_1(z) = \sum_{i=1}^3 \frac{w_i}{z + x_i} + \epsilon \quad (\text{B.1})$$

where x_i are the zeroes of the third Laguerre polynomial $L_3(x)$ and w_i is the corresponding weight function of the Laguerre quadrature integration given on page 923 of reference 16. The error for the given range of the variable is $|\epsilon| < 3 \times 10^{-6}$. The error analysis of (B.1) was done by J. Todd¹⁷. This formula was used to do the calculation for graphs of ξ_1 from five through seven for $|z| > 10$.

$y > 10, x = 0$ or $|z| > 100$ and $|\arg z| \leq \pi/4$

For these ranges of variables the following asymptotic expansions of $f_o(z)$ and $g_o(z)$ were used.

$$f_o(z) \approx \frac{1}{z} \left(1 - \frac{2!}{z^2} + \frac{4!}{z^4} - \frac{6!}{z^6} + \dots \right) \quad (\text{B.2})$$

$$g_o(z) \approx \frac{1}{z^2} \left(1 - \frac{3!}{z^2} + \frac{5!}{z^4} - \frac{7!}{z^6} + \dots \right) \quad (\text{B.3})$$

$|z| < 10$ and $|\arg z| < \pi/4$

For this range of variables a Taylor series expansion technique was used. For points where $y = 0$, that is, on the real axis $f_o(x)$ and $g_o(x)$ were calculated using infinite series expansions for $0 < x < 1$ and approximation formulas developed by Hastings given on page 233 of Reference 16. To obtain $f_o(a[1 - Mj])$ and $g_o(a[1 - Mj])$ for small M the following Taylor series expansion in terms of M were made using (A.14) and (A.15)

$$g[a(1 - Mj)] = g(a) + \sum_{n=1}^{\infty} A_{2n} M^{2n} + j \sum_{n=0}^{\infty} A_{2n+1} M^{2n+1} \quad (\text{B.4})$$

$$f[a(1 - Mj)] = f(a) + \sum_{n=1}^{\infty} B_{2n} M^{2n} + j \sum_{n=0}^{\infty} B_{2n+1} M^{2n+1} \quad (\text{B.5})$$

where

$$A_{2n-1} = \frac{-a^{2n-1} f_o(a)}{(2n-1)!} + \sum_{m=1}^n (-1)^{m+1} \frac{(2m-2)!}{(2n-1)!} a^{2(n-m)} \quad (\text{B.6})$$

$$A_{2n} = -\frac{a^{2n} g_0(a)}{(2n)!} + \sum_{m=1}^n (-1)^{m+1} \frac{(2m-1)!}{(2n)!} a^{2(n-m)} \quad (\text{B.7})$$

and

$$\left. \begin{aligned} B_n &= \frac{a}{n} A_{n-1} \\ B_1 &= ag(a) \end{aligned} \right\} \quad (\text{B.8})$$

This expansion is valid for $M < 1$ and therefore was used to obtain the graphs on Figures 5 and 6.

$$\underline{x = |y| \text{ and } 0 < x < 10}$$

For this range of variables, an infinite series expansion was used. The series were obtained using formulas on page 232 of Reference 16. This was used to produce the graphs in Figure 7.

$$\underline{x \rightarrow +0 \quad 0 < y < 10}$$

In this range of variables, formulas (A.11) and (A.12) were used with the power series expansions for $\cosh(y)$, $\sinh(y)$, $\text{shi}(y)$ and $\text{chi}(y)$. This was used to obtain the graphs for Figure 8.

Appendix C: Landau's Problem

In 1963 Drummond¹⁵ stated that Landau's half-space problem was physically equivalent to the problem of an infinite charged sheet placed in an infinite plasma at $x = 0$ carrying an oscillation surface charge of $2\epsilon_0 E_0$ if the particles are assumed to pass freely through the charged sheet. The methods of this thesis are suitable for proving this statement.

In order to solve this problem we will use Equation (61) with $v = 0$ and the charge sheet placed at the $x = 0$ in Poisson's equation in the following way.

$$\frac{\partial E}{\partial x} = \frac{e}{\epsilon_0} \int_{-\infty}^{+\infty} f \, d v + 2E_0 e^{j\omega_0 t} \delta(x) \quad (C.1)$$

where the second term on the right is the effect due to the sheet of surface charge $2\epsilon_0 E_0 e^{j\omega_0 t}$.

In order to do this problem by the transform method an important fact must be observed. The value of $E(x)$ as $x \rightarrow \pm \infty$ does not tend to zero but to some constant value. The reasonableness of this statement comes from the observation that when there is no plasma the electric field due to the charge sheet would be $E_0 e^{j\omega_0 t}$ for $0 < x < +\infty$ and $-E_0 e^{j\omega_0 t}$ for $0 > x > -\infty$. Because of the symmetry of the problem it would be convenient to write $E(x, t)$ in the plasma as

$$E(x, t) = E_1(x, t) + E_\infty \operatorname{sgn}(x) e^{j\omega_0 t} \quad (C.2)$$

where $\text{sgn}(x)$ is defined by (92) and E_∞ is a boundary value to be determined. In order to obtain E_∞ , Landau assumed that $E_1(x, t) \rightarrow 0$ as $x \rightarrow \infty$ and that the electric displacement defined by

$$D = \epsilon_M E(x, t) \quad (\text{C.3})$$

is continuous across the boundary at infinity. For free space $\epsilon_M = \epsilon_0$ and for the plasma $\epsilon_M = \epsilon_\rho = \epsilon_0(1 - X) = \epsilon_0 K_0$. This condition gives us

$$E_\infty = E_0 / (1 - X) = E_0 / K_0 \quad (\text{C.4})$$

Knowing that $d \text{sgn}(x)/dx = 2\delta(x)$ equations (C.1) and (61) written in terms of E_1 become

$$\frac{\partial f}{\partial t} + v \frac{\partial f}{\partial x} + \frac{e}{m} [E_1 + e^{j\omega_0 t} E_\infty \text{sgn}(x)] \frac{dF_0}{dv} = 0 \quad (\text{C.5})$$

$$\frac{\partial E_1}{\partial x} = \frac{e}{\epsilon_0} \int_{-\infty}^{+\infty} f dv + 2\delta(x) e^{j\omega_0 t} [E_0 - E_\infty] \quad (\text{C.6})$$

Taking the combined Fourier Laplace transform of (C.5) and (C.6) as was done for Equations (66) and (67), (Note:

$$\int_{-\infty}^{+\infty} \text{sgn}(x) e^{jkx} dx = \frac{2}{jk} \quad) \quad (\text{C.7})$$

then solving for the transform of E_1 and taking the inverse transforms (throwing out the transient terms) we obtain

$$E_1 = E_0 \frac{j e^{j\omega_0 t}}{\pi} \int_{-\infty}^{+\infty} \frac{(K_0 - K(\omega, k))}{k K_0 K(\omega, k)} e^{-jkx} dk \quad (C.8)$$

which is equivalent to Equation (37) in Landau's paper.

Appendix D: Characteristic Zeroes

Introduction

Landau stated and Shure showed in his Ph.D. thesis that there is one characteristic zero k_1 of the function $K_+(\omega_0, k, 0)$ which resides on the imaginary axis above the axis of reals in the k -plane for $\omega_0 < \omega_p$ if $F_0(v)$ is a maxwellian distribution. I plan to generalize this result and prove that this zero exists for any symmetric single hump function. I will also show that when u_0 is non-zero, this zero moves off the imaginary axis into the left half of the upper-half complex k -plane.

In order to prove the following two theorems we will use the arguement theorem from Whittaker and Watson²² which states that the number of zeroes of a function $G(z)$ enclosed in some closed contour of the complex z -plane in which $G(z)$ is analytic is equal to "the change in the arguement of $G(z)$ around the contour divided by 2π " if the order of the zeroes is unity and if there are no poles within or on the contour C' . It can be further shown that if a mapping of this contour C' is made from the complex z -plane to the complex W -plane (where $W = G(z)$), the number of zeroes of $G(z)$ within C' is equal to the number of times the mapping encircles the origin in the W -plane. It is this mapping procedure which will be used to show that the particular zero exists.

k_1 for $u_0 = 0$

Theorem II:

If $F_0(v)$ and $\frac{dF_0}{dv}$ are continuous single valued functions on the real v -axis and F_0 has the following properties

$$F_0(v) = F_0(-v)$$

$$\int_{-\infty}^{+\infty} F_0(v) dv = 1$$

and $F_0(v)$ is monotonically increasing when $-\infty < v < 0$ and monotonically decreasing when $0 < v < \infty$, then $K_+(\omega_0, k, 0)$ ($\omega_0 > 0$) has a zero $k_1 = jk_0$ (where k_0 is some positive number), when $X > 1$.

To prove this theorem we will soon show that there is one zero of $K_+(\omega_0, k, 0)$ for $X > 1$ above the real k -axis. From Corollary I of Theorem I following Equation (42), it is evident that if k_1 is a zero of $K_+(\omega_0, k, 0)$ then so is $-k_1^*$. If there is only one zero above the real k -axis, then $k_1 = -k_1^*$; and consequently $k_1 = jk_0$. To finish the proof of the theorem, all that we have to do is prove that there is only one zero of $K_+(\omega_0, k, 0)$ above the real k -axis. In order to do this we will prove that the mapping of a contour which surrounds the upper k -plane encircles the origin in the W -plane only once.

In order to do this we will analyze the function $K_+(\omega_0, k, 0)$ in terms of a different set of variables. Let us define the variable $S = \frac{\omega_0}{k}$ and the new function $V(X, S, u_0)$ where

$$V \left(\frac{\omega_p}{\omega_0}, \frac{\omega_0}{k}, u_0 \right) = K_+(\omega_0, k, u_0) \quad (D.1)$$

We will analyze $V(X, S, 0)$ in the complex S -plane instead of K_+ in the complex k -plane for convenience. The upper k -plane maps into the lower S -plane, so that showing that there is one zero in the lower S -plane means that there is one in the upper k -plane.

Figure 14 shows the C' contour in the S -plane whose mapping into the W -plane is shown in Figure 15. The $R \rightarrow \infty$ means that C' is enclosing the entire lower half complex S -plane. The numbers indicate the corresponding points on the contour C' and its mapping. The contour in Figure 15 give the general features of the mapping which next will be discussed in detail.

The mapping $W = V(X, S, 0)$ produces the following set of equations for S on the real axis which follows from the definition (D.1) and (76).

$$\operatorname{Re}(W) = 1 - X S^2 \int_{-\infty}^{+\infty} \frac{F_0(v) - F_0(S)}{(v - S)^2} dv \quad (D.2)$$

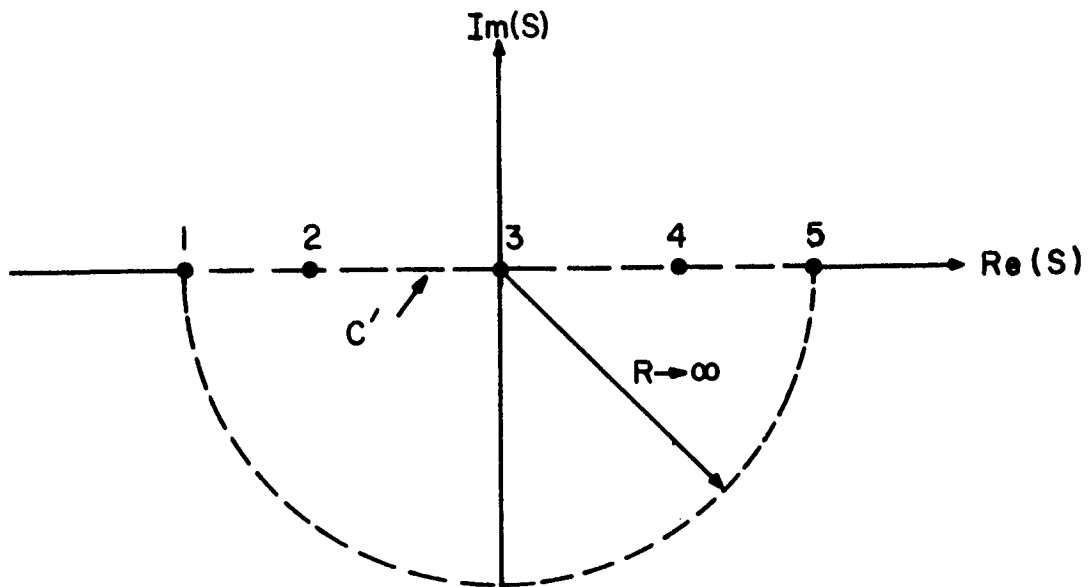

C' -CONTOUR IN S -PLANE FOR $U_0=0$
FIGURE 14

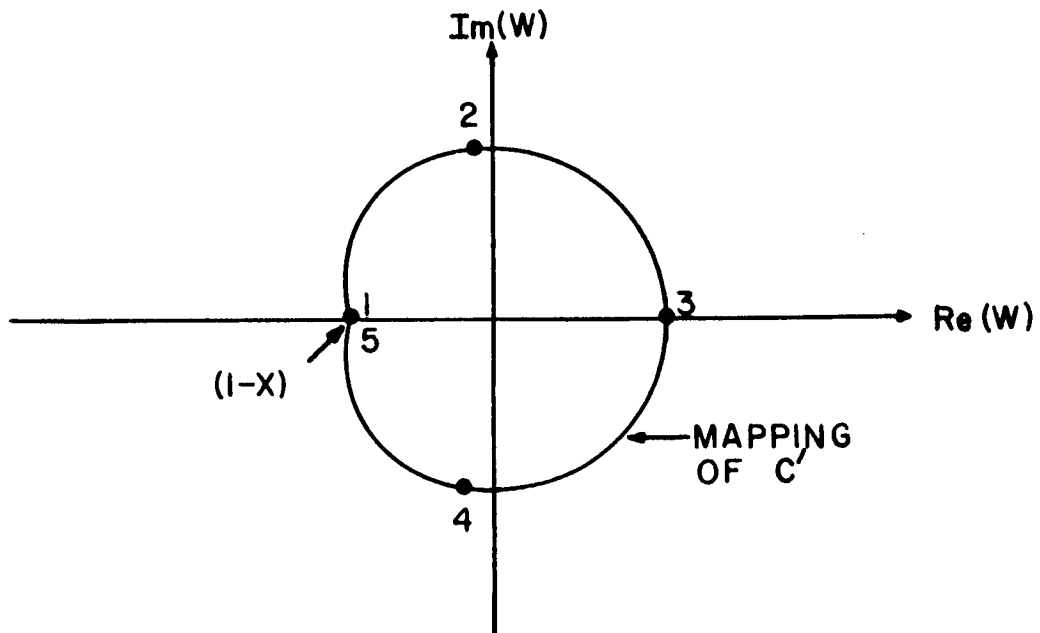

MAPPING OF C' IN W -PLANE
FIGURE 15

$$\text{Im}(W) = \pi X S^2 \left(\frac{dF_0}{dv} \right)_{v=S} \quad (\text{D.3})$$

From (D.2) and (D.3), the following statements about W can be made:

- 1) As $S \rightarrow -\infty$, $\text{Re}(W) \rightarrow 1 - X$, $\text{Im}(W) \rightarrow |\varepsilon|$ when $\varepsilon \rightarrow 0$
since $dF_0/dv > 0$ for $v < 0$.
- 2) As $S \rightarrow +\infty$, $\text{Re}(W) \rightarrow 1 - X$, $\text{Im}(W) \rightarrow -|\varepsilon|$ when $\varepsilon \rightarrow 0$
since $dF_0/dv < 0$ for $v > 0$.
- 3) As $S \rightarrow 0$, $\text{Re}(W) \rightarrow 1$, $\text{Im}(W) \rightarrow 0$
- 4) As $|S| \rightarrow +\infty$, $\text{Re}(W) \rightarrow 1 - X$, $\text{Im}(W) \rightarrow 0$ ($-\pi < \arg(S) < 0$)

Statement 4 says that the semicircular contour in the S -plane maps onto the same point $W = 1 - X$ when $R \rightarrow \infty$. Statements 1 and 2 say that the contour along the real axis approaches $(1 - X)$ the $\text{Re}(W)$ axis from below or above depending whether S tends to $+\infty$ or $-\infty$ respectively. Statement 3 shows that the only other point where the mapping crosses the real W -axis -- that is at $S = 0$ -- crosses it for $\text{Re}(W) > 0$. The fact that $F_0(v)$ and dF_0/dv are continuous and single valued assures the analyticity of $V(X, S, 0)$ in the complex S -plane which insures that the mapping of C' onto the W -plane is a continuous curve. The continuity of the mapping combined with Statements 1 through 4 prove that the origin in the W -plane is encircled.

k_1 for $u_0 > 0$

Theorem III:

If $F_0(v)$ is a function which satisfies all the conditions specified in Theorem II then $K_+(\omega_0, k, u_0)$ has a zero k_1 for $X > 1$ for which $k_1 = -\alpha + j\beta$ where $\alpha, \beta > 0$.

To prove this theorem we will again analyze $V(X, S, u_0)$. Proving that $S_1 = \omega_0/k_1$ is below the axis of reals to the left of the imaginary axis shows that $k_1 = -\alpha + j\beta$. In order to show that S_1 is where we said, we will make a mapping from the S to the W -plane of the contour C' which encircles the left side of the lower half plane. Figure 16 shows the contour C' in the S -plane and Figure 17 shows its mapping onto the W -plane. Again the numerals indicate the corresponding points between the two graphs.

For the contour along the real axis the following equation gives the mapping

$$\operatorname{Re}(W) = 1 - X S^2 \int_{-\infty}^{+\infty} \frac{f(v) - F(S - u_0)}{(v - S + u_0)^2} \quad (\text{D.4})$$

$$\operatorname{Im}(W) = \pi X S^2 \frac{dF_0}{dv} \quad (\text{D.5})$$

$$v = S - u_0$$

For the contour C' along the imaginary axis the following equations describe the mapping

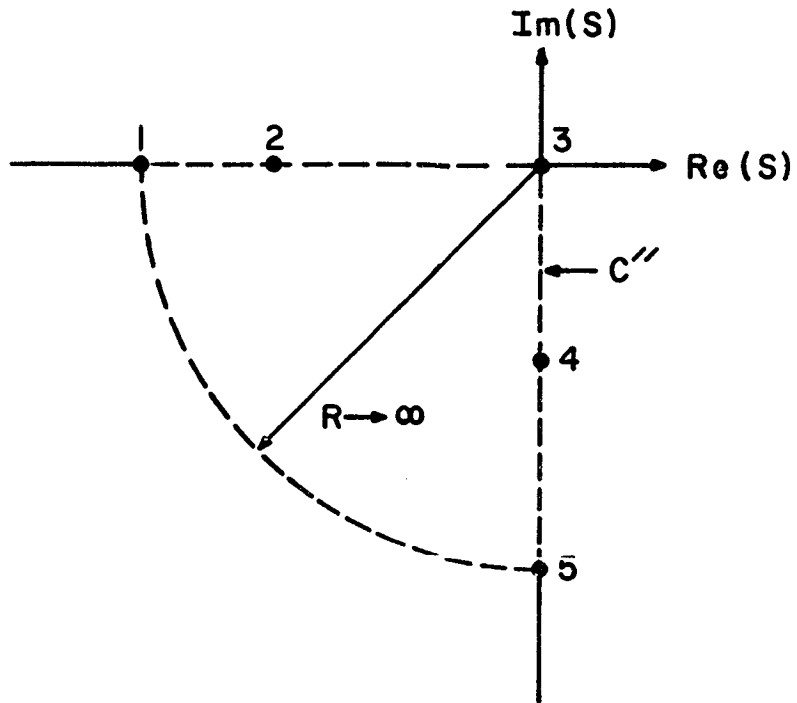

C'' CONTOUR IN S -PLANE FOR $u_0 > 0$
FIGURE 16

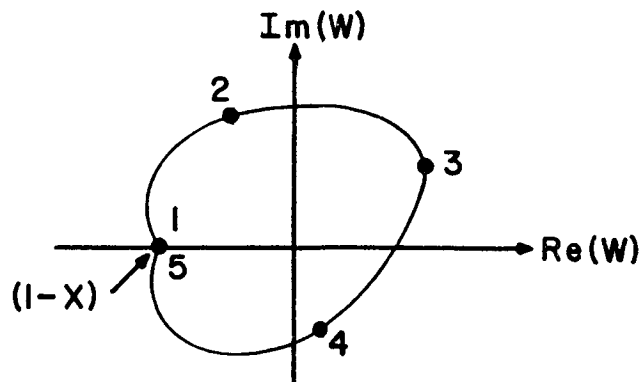

MAPPING OF C'' IN W -PLANE
FIGURE 17

$$\operatorname{Re}(W) = 1 + X S_o^2 \int_{-\infty}^{+\infty} \frac{(v + u_o) (dF_o/dv) dv}{(v + u_o)^2 + S_o^2} \quad (\text{D.6})$$

$$\operatorname{Im}(W) = -X S_o^3 \int_{-\infty}^{+\infty} \frac{(dF_o/dv) dv}{(v + u_o)^2 + S_o^2} \quad (\text{D.7})$$

because $S = -jS_o$ where $S_o > 0$. Statements 1 and 4 describing the mapping used to prove Theorem II apply here also. We must show statements which correspond to Statements 2 and 3. We must prove that:

$$5) \text{ As } S_o \rightarrow +\infty, \operatorname{Re}(W) \rightarrow 1 - X \quad \operatorname{Im}(W) \rightarrow -|\epsilon|.$$

$$6) \text{ If } \operatorname{Im}(W) = 0 \text{ then } \operatorname{Re}(W) > 0.$$

Statements 5 and 6 combined with 1 and 4 and the continuity of the mapping proves that the origin has been encircled when $X > 1$.

It is relatively easy to prove Statement 6. If $\operatorname{Im}(W) = 0$ then we can write

$$X S_o^2 \int_{-\infty}^{+\infty} \frac{(dF_o/dv) dv}{(v + u_o)^2 + S_o^2} = 0 \quad (\text{D.8})$$

If we multiply (D.8) by u_o and subtract it from (D.6) we get

$$\operatorname{Re}(W) = 1 + X S_o^2 \int_{-\infty}^{+\infty} \frac{v(dF_o/dv) dv}{(v + u_o)^2 + S_o^2} \quad (\text{D.9})$$

Since the numerator and denominator of the integrand of

(D.9) are always positive, $\text{Re}(W) > 0$. Statement 6 has been proved.

In order to prove Statement 5, an asymptotic expansion of $\text{Im}(W)$ must be made as $S_0 \rightarrow \infty$. The asymptotic expansion will be made using the following formula.

$$\frac{1}{1+Z} = 1 + Z + \frac{Z^2}{1+Z} \quad (\text{D.10})$$

Using (D.10), (D.7) can be rewritten as

$$\text{Im}(W) = -\frac{2X u_0}{S_0} - \frac{X}{S_0^3} \int_{-\infty}^{+\infty} \frac{(v + u_0)^+ (dF_c/dv) dv}{1 + \frac{(v + u_0)^2}{S_0^2}} \quad (\text{D.11})$$

As $S_0 \rightarrow +\infty$ the integral on the right hand side of (D.11) tends to the constant value $4(3 \langle v^2 \rangle + u_0^2) u_0$, where $\langle v^2 \rangle$ represents the second velocity moment of $F_0(v)$. This shows that the first term on the right hand side dominates if we take S_0 sufficiently large. Consequently we have shown that $\text{Im}(W) \rightarrow -|\epsilon|$ as $S_0 \rightarrow +\infty$. We have therefore proved that the origin in the W -plane is encircled for $X > 1$, and consequently proved Theorem III.

BIBLIOGRAPHY

- 1 Landau, L., J. of Phys. (U.S.S.R.) 10, 25, (1946).
- 2 Vlasov, A., J. of Phys. (U.S.S.R.) 9, 25 (1945).
- 3 Rydbeck, O.E.H., Electromagnetic and Space Charge Waves in Inhomogeneous Structures, Research Report No. 8 of the Research Laboratory of Electronics, Chalmers University of Technology, Gothenburg, Sweden (1960).
- 4 Shure, F. S., Boundary Value Problems in Plasma Oscillations, U. of Michigan, Ph.D. thesis (1962).
- 5 Shure, F. S., Plasma Physics (J. of Nuc. E Part C) 6, 1, (1964).
- 6 Van Kampen, N. G., Physica 21, 949, (1955).
- 7 Case, K. M., Amn. Phys. 9, 1, (1960).
- 8 Lighthill, M. J., Fourier Analysis and Generalized Functions, Cambridge University Press (1964).
- 9 Van Der Pol, B., and L. H. Bremmer, Operational Calculus Based on the Two Sided Laplace Integral, Cambridge University Press (1964).
- 10 Celman, H., Phys. of Fluids, 10, 1, (1967).
- 11 Sturrock, P. A., Phys. Rev., 112, 5, (1958).
- 12 Rolland, P., Phys. Rev., 140, 38, (1965).
- 13 Knopp, K., Theory of Functions II, Dover Book Publishers Inc., (1947), p. 34.
- 14 Englemann, F., M. Feix, E. Minardi, and J. Oxenius, IL Nuovo Cimento 22, 5, (1961).
- 15 Drummond, W. E., Rev. of Sc. Instr., 34, 7, (1963).
- 16 Abramowitz, M., and I. A. Stegun, Handbook of Mathematical Functions, Dover Publications, Inc. (1965).
- 17 Todd, J., J. Res. NBS, 52, (1954), RP 2508.
- 18 Cercignani, D., and Pagani, C. D., IL Nuovo Cimento, 25 B, 1, (1965).

- 19 Gould, R. W., Phys. Rev., 136, 4A, (1964).
- 20 Gunshor, R. L., J. of Ap. Phys., 37, 4, (1966).
- 21 Taylor, E. C., Phys. of Fluids, 6, 9, (1963).
- 22 Whittaker, E. T. and G. N. Watson, A Course in Modern Analysis,
Cambridge University Press (1963).

Errata Sheet for Scientific Report No. 316

Page 5: Second line below equation (10)

$$x = \frac{\omega^2 p}{\omega_0^2}$$

Page 6: Equation (13) An open parenthesis should be before $\sin a_+$.

Page 20: Equation (56) should have ΔE_{χ}

Page 28: Equation (64) should have

$$\frac{\partial^2 \phi}{\partial x \partial t}$$

Page 30: Sentence before equation (70) should be:

"Solve for f_1 in equation (68) and insert in (69) which is then solved for ϕ_1 to give. . . "

Page 44: Second line below equation (104) the expression in parenthesis should be: "(the infinite driving frequency limit)".

Page 56: Caption to Figure 9 should read

ξ_2 versus θ_0

Page 69: Second line above (130) the word should be "separation".

Page 77: Third line of third paragraph names should be Krook and Fokker-Planck.