

NASA CR 97491

NATIONAL AERONAUTICS AND SPACE ADMINISTRATION

CASE FILE

COPY

Technical Report 32-1282

*Improved Sampling and Analytical Procedure for
Nitrogen Tetroxide and Mixed Oxides of Nitrogen*

Stephen P. Vango

JET PROPULSION LABORATORY
CALIFORNIA INSTITUTE OF TECHNOLOGY
PASADENA, CALIFORNIA

October 15, 1968

NATIONAL AERONAUTICS AND SPACE ADMINISTRATION

Technical Report 32-1282

*Improved Sampling and Analytical Procedure for
Nitrogen Tetroxide and Mixed Oxides of Nitrogen*

Stephen P. Vango

JET PROPULSION LABORATORY
CALIFORNIA INSTITUTE OF TECHNOLOGY
PASADENA, CALIFORNIA

October 15, 1968

TECHNICAL REPORT 32-1282

Copyright © 1968
Jet Propulsion Laboratory
California Institute of Technology

Prepared Under Contract No. NAS 7-100
National Aeronautics & Space Administration

Preface

The work described in this report was performed by the Space Sciences Division of the Jet Propulsion Laboratory.

Contents

I. Introduction	1
II. Determination of Nitric Oxide	1
III. Sampling Technique	3
IV. Nitrogen Tetroxide Determination	4
V. Water Determination	5
VI. Nitrosyl Chloride	9
VII. Ash	9
VIII. Conclusion	9

Figures

1. Sampling assembly for NO determination	2
2. Pyrex sample bulb	3
3. Sampling assembly for determination of N_2O_4 , H_2O , and $NOCl$	3
4. Weight capacities of sample bulbs filled with N_2O_4	4
5. Apparatus for H_2O_2 oxidation of N_2O_4 at elevated temperature	5
6. Water determination apparatus	6
7. Breaker unit	7
8. Apparatus for connecting water trap to chromatographic column	8

Abstract

A scheme for sampling and analyzing nitrogen tetroxide and the mixed oxides of nitrogen is presented. The procedures described overcome some serious deficiencies of the usual military procedures.

The improved sampling procedure provides meaningful samples for these hygroscopic and volatile materials, and the analytical procedure eliminates an inherent error in the military procedures when carbon dioxide is present as a dissolved impurity. Some other modifications in the military procedure are also described.

Improved Sampling and Analytical Procedure for Nitrogen Tetroxide and Mixed Oxides of Nitrogen

I. Introduction

The sampling and analytical technique to be described has been applied specifically to the mixed oxides of nitrogen, a mixture referred to as MON-10 which consists of approximately 10% by weight of nitric oxide dissolved in nitrogen tetroxide containing trace quantities of impurities. The method can also be applied to straight nitrogen tetroxide. Sampling difficulties due to hygroscopicity and high volatility have been circumvented by sampling in a closed system.

The method selected must give accurate results without interference from trace impurities. The impurities present are dependent on the manufacturing procedure.

An impurity recently discovered in MON-10 was an appreciable quantity (1% by weight) of dissolved carbon dioxide.¹ In Mil-P-27408 (USAF) of July 31, 1964, the sample of nitrogen tetroxide is quenched in an excess of 0.5 N sodium hydroxide solution and the excess hydroxide then is back-titrated with standard 0.1 N nitric using phenolphthalein indicator. In this method the carbon dioxide reacts with excess sodium hydroxide to give sodium carbonate which is converted to sodium bicarbonate in the acid back-titration to a phenolphthalein

¹A method for determining carbon dioxide is presented in a report by Vango, S. P., "Technique for Determining Gases Dissolved in Fuels, Oxidizers, and Liquids in General," Technical Report 32-1236, Jet Propulsion Laboratory, Pasadena, California, April 1, 1968.

end point. Because the equivalent weights of nitrogen tetroxide and carbon dioxide are so close in value (46.01 and 44.01), even with considerable carbon dioxide, no appreciable discrepancy is apparent in a material balance summation for the percentages of the various constituents. In other words, in this method the carbon dioxide goes undetected and is reported as nitrogen tetroxide.

Aside from its lack of contribution, the carbon dioxide present in oxidizers can cause unstable engine performance because of the tendency for dissolved gases to leave the solution due to pressure drops across valves, orifices, etc. A 1% by weight of carbon dioxide represents over 50 cm³ of dissolved carbon dioxide per gram of oxidizer and far exceeds the volume of dissolved helium known to cause unsteady engine performance. In the method to be described, carbon dioxide is eliminated and not reported as nitrogen tetroxide.

The following procedures describe the analysis of nitric oxide, nitrogen tetroxide, water, nitrosyl chloride, and ash in oxides of nitrogen. Sampling and analysis of nitric oxide are presented first since the other components are determined on the reserved material from the nitric oxide assay.

II. Determination of Nitric Oxide

The determination of nitric oxide is based on the reaction of nitric oxide with oxygen to give nitrogen

tetroxide. The nitric oxide content is calculated from the weight of oxygen consumed in oxidizing the nitric oxide. The method to be described differs from the military procedure in some minor details. A glass reaction vessel, rather than a metal one, is used. The glass vessel permits visibility but is more hazardous to handle. The glass vessel is lighter and more suited for weighing on a regular analytical balance. The glass unit is evacuated initially as well as after completing the reaction with oxygen. This procedure eliminates the need for a correction due to the weight of excess oxygen present in the vessel. The accuracy realized in this determination using the method to be outlined is $\pm 0.05\%$ absolute.

Figure 1 shows the type of flask used in the nitric oxide determination. The flask can be constructed from a 100-ml Kjeldahl flask. The wall in the Kovar tubing of the Kovar to Pyrex glass seal should be at least 0.010 in. thick. Such seals can withstand several hundred psi, although in this application the pressures experienced will be much less. The overall weight of the flask is kept to a minimum so that weighings can be carried out on an

analytical balance. The valves used are modified $\frac{1}{8}$ -in. stainless-steel Hoke valves. The $\frac{1}{8}$ -in. male pipe threads were replaced, by welding, with $\frac{1}{4}$ -in. male Swagelok fittings. The packing in the valves is Teflon. The Hoke catalogue number for this valve is 321A. A Hoke valve, which is now available and which could also be used, comes with Gyrolok fittings. The catalogue number for this valve is 3212G4Y.

The procedures for sampling and analysis of nitric oxide are as follows:

- (1) The evacuated, weighed flask is attached to the sample holder as shown in Fig. 1. About 35 to 45 ml of liquid MON-10 are admitted into the flask via the evacuated tubulation between the sample holder and the flask.
- (2) The liquid oxidizer is frozen by immersing the portion of the flask containing the liquid phase in liquid nitrogen. After freezing of the liquid phase, the whole flask is immersed in the liquid nitrogen in order to freeze out the oxidizer present in the gas phase.
- (3) The valve on the flask is closed and the contents thawed in water. After thorough drying and allowing time for equilibrium with the laboratory air, the flask is reweighed. The gain in weight represents the sample weight.
- (4) The flask is attached to a $\frac{1}{4}$ -in. oxygen line previously purged. Tank oxygen is used and traces of moisture are removed by passing through an in-line glass tube which is $\frac{1}{2}$ in. by 24 in. long and packed with anhydrous. Prior to admitting oxygen to the flask, the magnetically stirred oxidizer in the flask is cooled with ice water. With the regulator on the oxygen cylinder set to 40 psi, oxygen is admitted to the flask by opening the flask valve. The dark green color of MON-10 gradually lightens and the oxygen flow indicated on an in-series flow meter tapers off. When the green color has disappeared and the oxygen flow has all but ceased, the valve on the flask is closed. With the valve closed, nitrogen dioxide fumes drift into the neck of the flask. From time to time, additional oxygen is admitted which causes the neck of the flask to be cleared of brown fumes, and the flow meter reading briefly reaches a high value followed by a rapid decay. The periodic opening of the valve in the flask is repeated until it no longer causes the brown fumes to disappear from

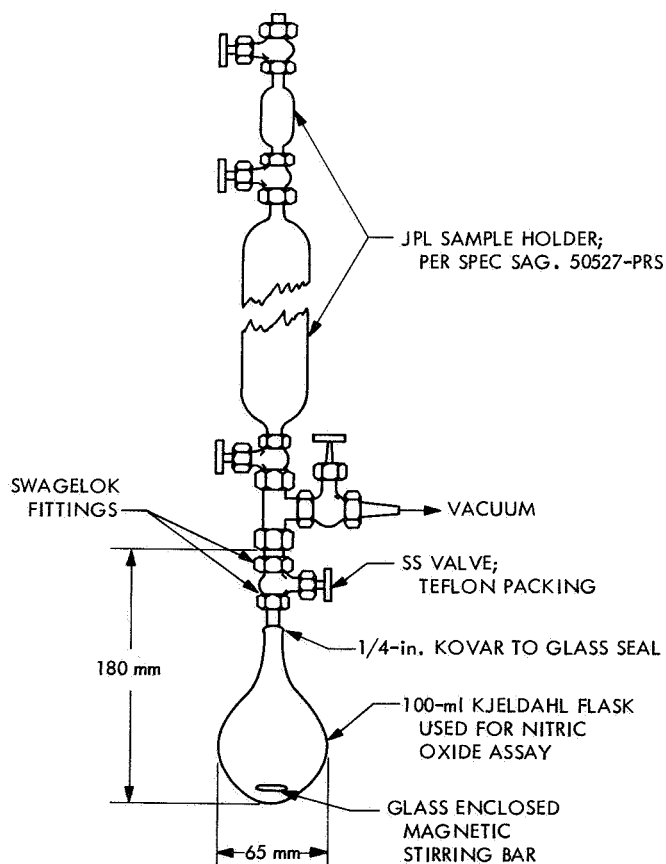

Fig. 1. Sampling assembly for NO determination

the neck of the flask. The contents of the flask are stirred for an additional five minutes.

- (5) The flask is disconnected from the oxygen line and immersed in liquid nitrogen. When the flask contents are completely frozen, as indicated by the quiescence of the liquid nitrogen, the excess oxygen is pumped off. The pressure in the flask is reduced to 100 μm or less.
- (6) The valve on the flask is closed, the flask is removed from the vacuum line, the contents are thawed in water, and after thorough drying and allowing for equilibrium with the laboratory air, the flask is reweighed on an analytical balance. The gain in weight represents the weight of oxygen consumed in oxidizing the nitric oxide to nitrogen tetroxide. In order to realize the maximum precision, weighings are made to 1/10 mg.

The percent nitric oxide is calculated as follows:

$$\% \text{ NO} = \frac{\text{weight of oxygen} \times 1.875 \times 100}{\text{weight of MON-10 sample}}$$

The contents of the flask from the nitric oxide determination are reserved for the assay of nitrogen tetroxide, nitrosyl chloride, water, and ash. The following sampling procedure to be described is that used for determining nitrogen tetroxide, nitrosyl chloride, and water.

III. Sampling Technique

Figure 2 shows the sample bulbs used for weighing the samples. These sample bulbs are made of Pyrex. The outside diameter of the stem is critical. It must fit snugly into a 1/8-in. Swagelok sleeve so that when the Swagelok nut is tightened down on a Teflon sleeve, a gas-tight joint is obtained. The glass bulbs are from 10 to 15 mm in diameter and sufficiently thick to survive evacuation, and thin enough to be readily broken when desired. These bulbs are furnace-annealed and then stored in a glass desiccator.

Figure 3 shows the hardware used to connect the sample bulb to the flask of reserved material from the nitric oxide determination.

The sampling procedure is as follows:

- (1) The sample bulb, weighed to 1/10 mg, is attached to the sample holder as shown in Fig. 3. The sample bulb and interconnecting tubulation are

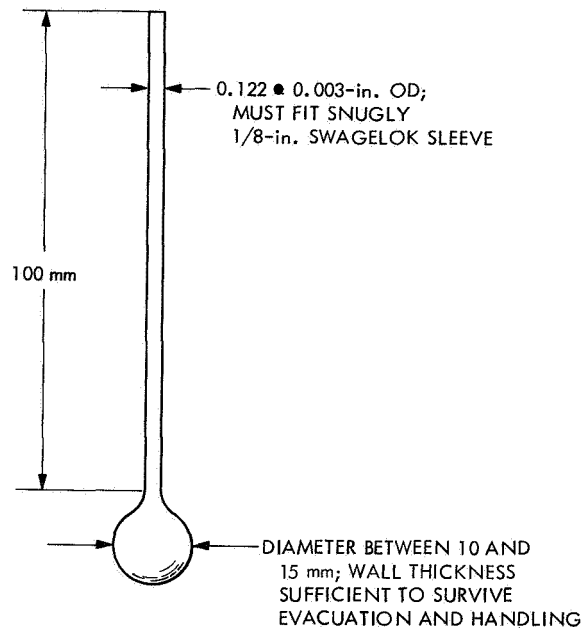

Fig. 2. Pyrex sample bulb

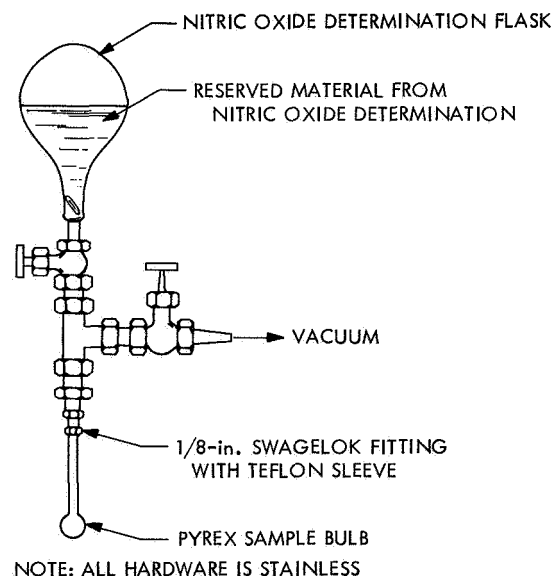

Fig. 3. Sampling assembly for determination of N_2O_4 , H_2O , and NOCl

warmed with a heat gun while pumping to remove adsorbed traces of water. Pumping is continued, using a mechanical pump protected against contaminants with a liquid nitrogen trap, until the pressure as read on a Pirani or thermocouple gauge drops to 100 μm or less.

- (2) When the desired vacuum has been obtained in the sample bulb, the valve to the vacuum pump

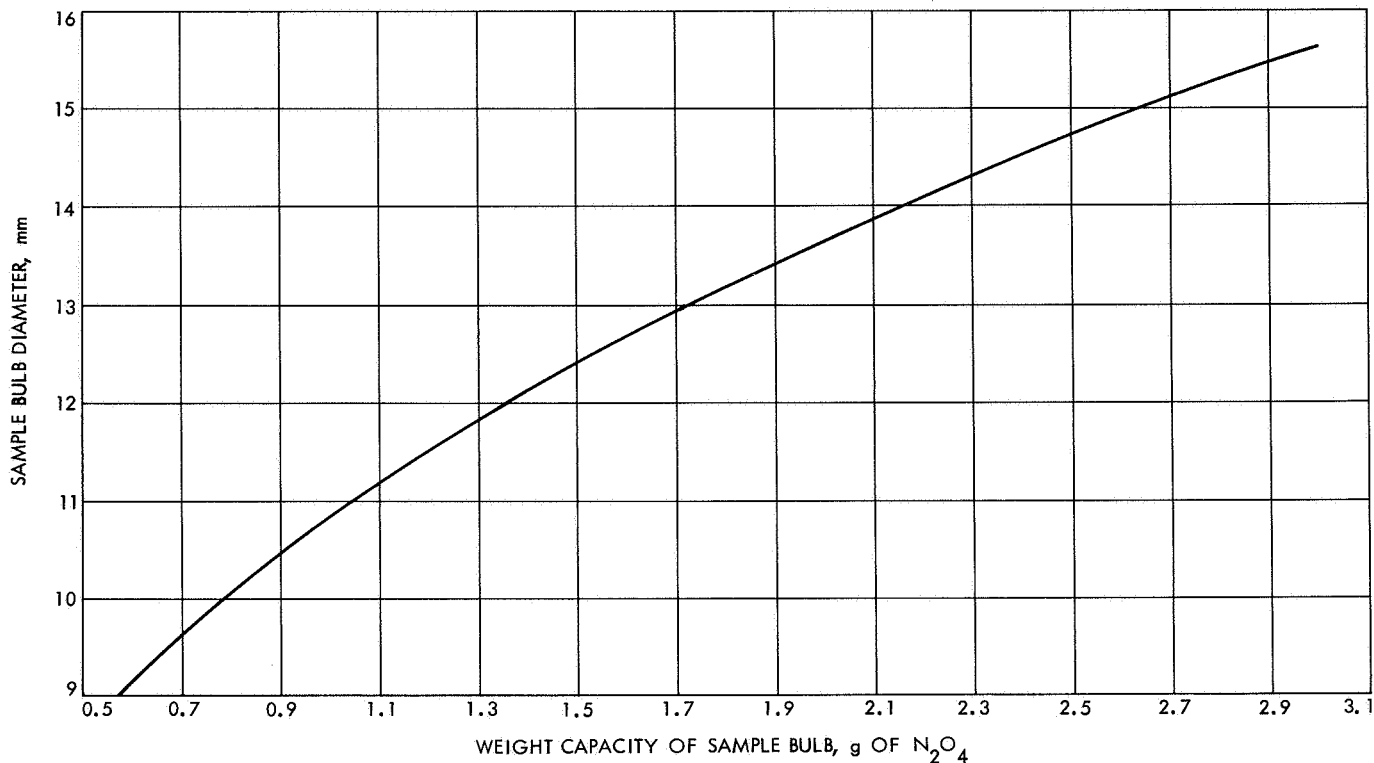

Fig. 4. Weight capacities of sample bulbs filled with N₂O₄

is closed and the nitrogen tetroxide is admitted to the sample bulb by slowly opening the valve on the sample holder. Cooling the sample bulb slightly by momentary immersion in liquid nitrogen facilitates the flow of oxidizer into the sample bulb. The weight of nitrogen tetroxide desired is estimated from the volume of liquid in the sample bulb. A density of 1.5 g/cm³ for nitrogen tetroxide is sufficiently accurate for this estimate. To facilitate the estimation of the weight of nitrogen tetroxide present in a sample bulb, it is helpful to have a plot of the bulb diameters against the weight capacities of these bulbs, as shown in Fig. 4. With a little practice, the weight estimates can be surprisingly accurate.

- (3) With the desired sample weight in the sample bulb, the bulb contents are frozen in liquid nitrogen. Initially, the bulb is immersed in liquid nitrogen only up to the level of the contained liquid oxidizer. A laboratory jack is a convenient way of adjusting the height of the liquid nitrogen dewar. With the oxidizer frozen, the sample bulb is completely immersed in liquid nitrogen. When the liquid nitrogen has become quiescent, the bulb

is sealed off at about the mid-point on the stem with a hand torch. While making the seal, the sample bulb is held by its stem in a pair of tweezers.

- (4) The sealed-off sample bulb is thawed by heating in a stream of warm air from a heat gun. The thawed bulb and the drawn-off portion of its stem are placed into a numbered beaker.
- (5) The small beaker containing the sealed sample bulb and its drawn-off stem is placed into a vacuum desiccator to remove any surface moisture by vacuum prior to the reweighing of the sample bulb and its drawn-off stem. This weighing, like the original, is made to 1/10 mg.

The above sampling technique provides a meaningful sample accurately weighed for assay of the desired constituent. Let us now consider the nitrogen tetroxide determination.

IV. Nitrogen Tetroxide Determination

The bulb containing the weighed nitrogen tetroxide (0.8 g to 1.0 g) is placed into a 500-ml, 24/40 glass-stoppered Pyrex bottle containing 100 ml of water plus

20 ml of 30% hydrogen peroxide, previously chilled in ice water. The 24/40 stopper lubricated with Kel-F grease is inserted and the sealed bulb is broken by vigorously shaking the bottle, being careful to firmly hold the stopper in place. The shaking is continued until all fumes disappear. The bottle is replaced in the ice water to keep the contents cold and is shaken from time to time over a period of 10 to 15 min.

The stopper is removed, carefully rinsed off, and replaced with an air condenser as shown in Fig. 5. The contents of the bottle are heated on a steam bath for 45 min in order to completely convert the nitrogen tetroxide to nitric acid. This heating also serves to expel any dissolved carbon dioxide.

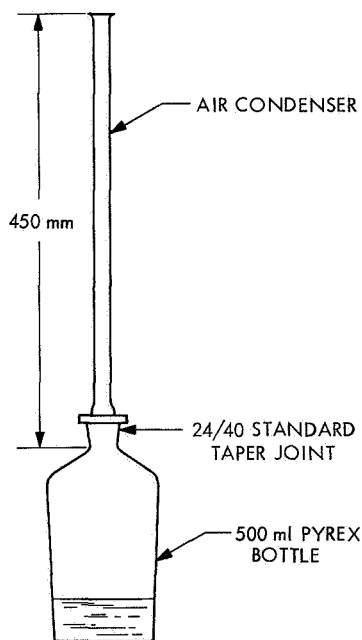

Fig. 5. Apparatus for H₂O₂ oxidation of N₂O₄ at elevated temperature

After the contents of the flask have been allowed to cool to ambient temperature, the air condenser is carefully rinsed with water and removed. A husky glass rod, flattened at one end, is used to crush the bulb and stem so that there is no entrapment of acid which would be difficult to titrate. The rod as well as the sides of the bottle are rinsed with water and the contents of the flask are magnetically stirred and titrated to a methyl red end-point using carbonate-free 0.5 N sodium hydroxide solution. A blank is run in a manner similar to the sample on all reagents used and subtracted from the sample titration.

If the oxidizer was nitrogen tetroxide, the percent nitrogen tetroxide was calculated as follows:

$$\% \text{N}_2\text{O}_4 \text{ in nitrogen tetroxide sample} = \frac{(\text{ml NaOH for sample} - \text{ml NaOH for blank}) \times N \times 4.601}{\text{weight of sample}}$$

If the sample assayed was MON-10, then the percent nitrogen tetroxide in the MON-10 determined on the sample reserved from the nitric oxide determination was calculated as follows:

$$\% \text{N}_2\text{O}_4 \text{ in MON-10} =$$

$$\left[\frac{(\text{ml NaOH sample} - \text{ml NaOH blank}) \times N \times 4.601}{\text{weight of sample}} \right] \times \left[1 + \frac{\% \text{NO}}{187.5} \right] - \left[(1.533) (\% \text{NO}) \right]$$

Let us next consider the water determination.

V. Water Determination

The military procedure for water is based on the evaporation of nitrogen tetroxide at 0°C with dry nitrogen gas until a two-phase system is obtained. At this point the residue contains 1.6% water. The percent water present is calculated from the volume of the two-phase residue and the starting volume. It is assumed that only nitrogen tetroxide is lost when dry nitrogen is bubbled through the nitrogen tetroxide at 0°C. This may not be such an unreasonable assumption considering that the water in the nitrogen tetroxide is present mostly as nitric acid. However, this assumption does not allow for the possibility of mechanically carrying away some of the nitric acid as a fine mist.

The method selected for water determination is based on the rigorous method developed by Gerald C. Whitnack and Clifford J. Holford and reported in the article "Determination of Water in Nitrogen Tetroxide" appearing in *Analytical Chemistry*, Vol. 21, pp. 801-803 (1949).

In the Whitnack-Holford method, the nitrogen tetroxide is eliminated by the reaction of the dissociated nitrogen tetroxide with hot anhydrous sodium carbonate. The equation for this reaction is:

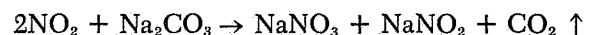

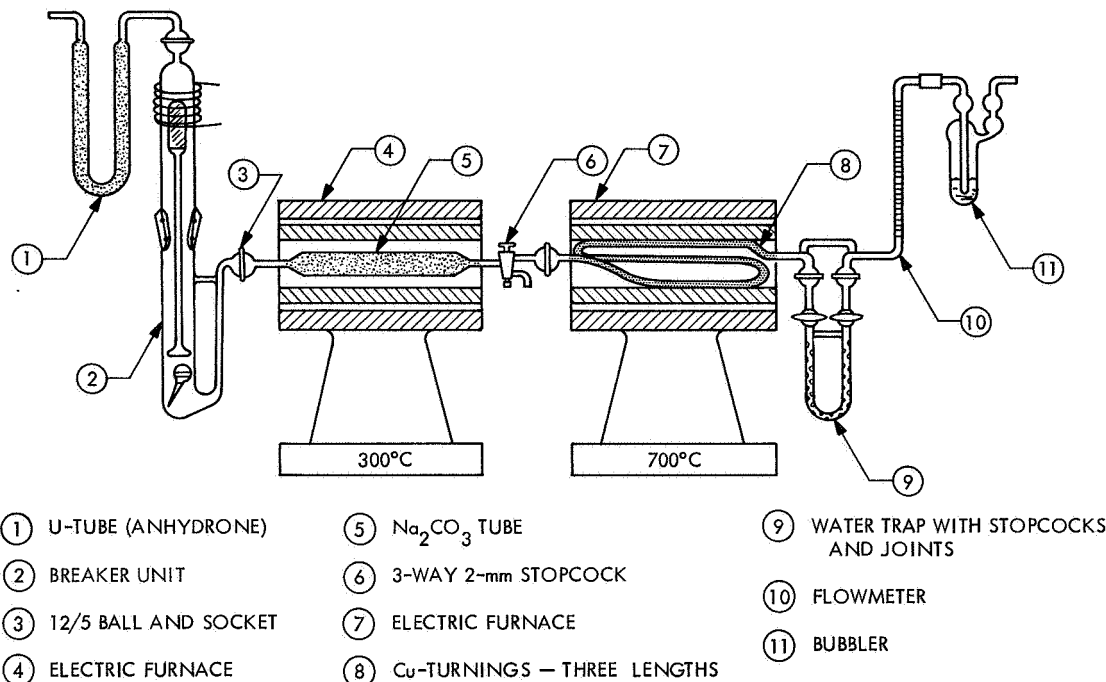

NOTE:

Kel-F GREASE USED ON JOINTS AND STOPCOCKS EXCEPT ON THE TRAP. APIEZOMN USED ON TRAP

Fig. 6. Water determination apparatus

The water, present mostly as nitric acid, is released as follows:

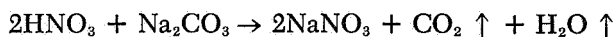

A tube containing hot copper turnings is used after the tube of hot anhydrous sodium carbonate to remove any traces of nitrogen dioxide or nitric acid which might get through. Figure 6 shows an overall sketch of the apparatus used to separate the water from the nitrogen tetroxide.

The water, in the original method, was weighed after collecting it in a drying tube. In our modification of the method, the water is trapped out at dry-ice temperature and then transferred to a gas chromatographic column for quantitative evaluation. This technique permits use of smaller samples with greater precision than is possible by weighing the absorbed water. Some of the other modifications to the Whitnack-Holford method are as follows:

- (1) The unit for breaking the sample bulb has been modified and is shown in Fig. 7.

- (2) Helium rather than nitrogen is used for purging. Helium is generally purer and drier than nitrogen gas.

- (3) Copper turnings are maintained at 700°C rather than 600°C. Three lengths of 15-mm Vycor tubing packed with copper turnings are used rather than a single length, an arrangement which permits more determinations between regeneration with hydrogen. Regeneration is made when the oxidized copper extends to half the length of packing.

Any column which will satisfactorily separate water can be used. We have successfully used a column packing consisting of 5% carbowax 20M (polyethylene glycol) on a solid support of powdered Teflon VI. The laboratory assembled unit had an 8-mm OD Pyrex tubing column, 30 ft long, and was maintained at 100°C by vapor heating. Helium flow was 50 cm³/min. A four-element hot-wire detector block was used and kept in a dewar jar at ambient temperature. The trap used to collect the water was connected to the column and detector by means of the glass assembly shown in Fig. 8. Small-

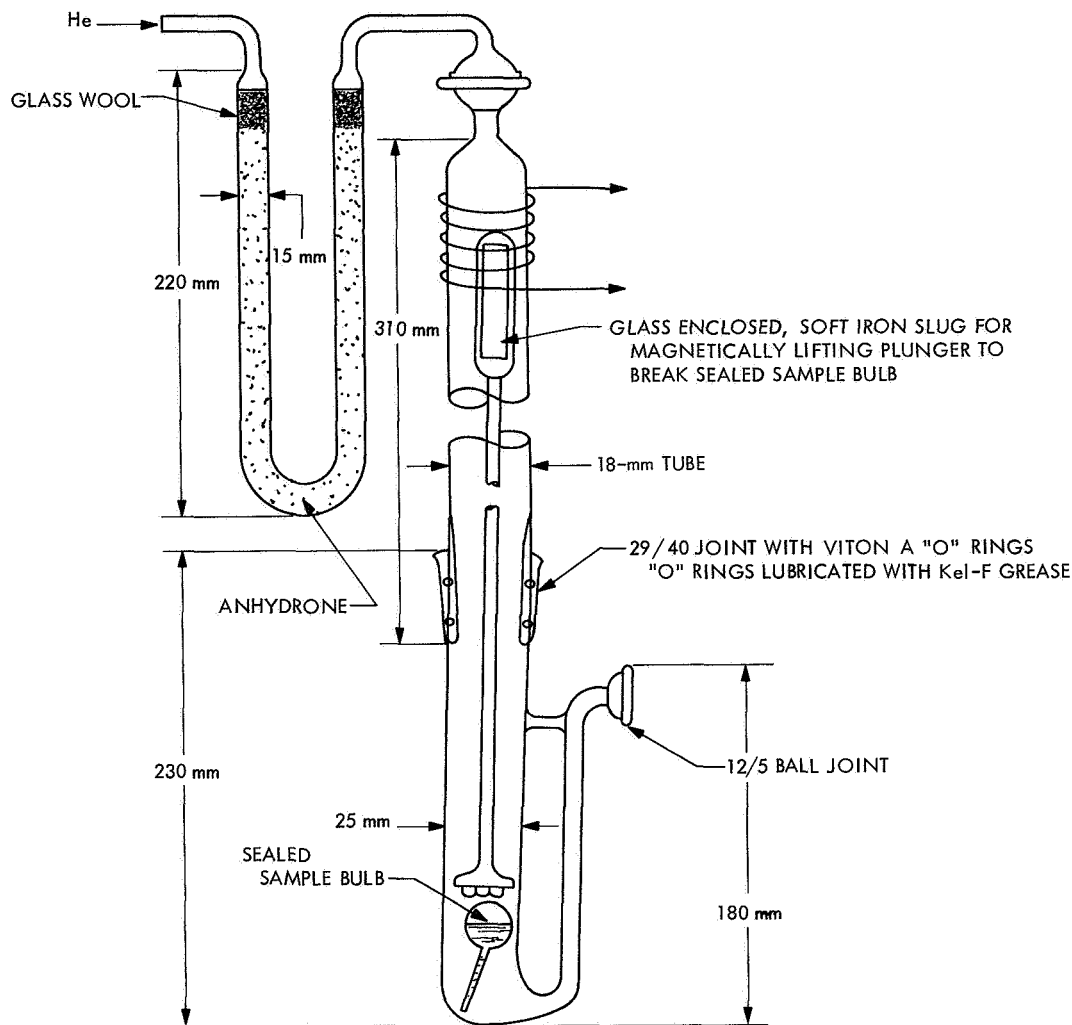

Fig. 7. Breaker unit

bore Teflon tubing was used to interconnect the various components.

Prior to introducing the trapped water from a water determination, it was found necessary to precondition the system with a $2\text{-}\mu\text{l}$ injection of water. With helium bypassing the trap (see Fig. 8), $2\ \mu\text{l}$ of water are injected into the tubulation above the closed stopcock 5. The trap is replaced and the trap evacuated up to stopcock 5 by opening stopcocks 3 and 4. With the pressure in the trap $50\ \mu\text{m}$ or less, the trap is cooled with liquid nitrogen, and stopcock 5 is opened to transfer the water into the trap and pump out the air present in the tubulation above stopcock 5. When the pressure is again below $50\ \mu\text{m}$, stopcocks 3, 4, and 5 are closed. The trap is warmed with a heat gun to thaw and

vaporize the water. The water is sent through the column by rapidly turning the necessary stopcocks so as to flow the helium through the trap loop.

The details for making a water determination on an oxidizer sample are as follows:

- (1) A $\frac{1}{2}\text{-g}$ sample, obtained as described in Section III, suffices for the water determination. The sealed bulb containing the weighed sample is placed into the breaker unit (2) as shown in Fig. 6.
- (2) Stopcock 6 is set so that helium flow purges the breaker unit and the anhydrous sodium carbonate tube but not the tube packed with copper turnings. The hot copper turnings are never exposed to air.

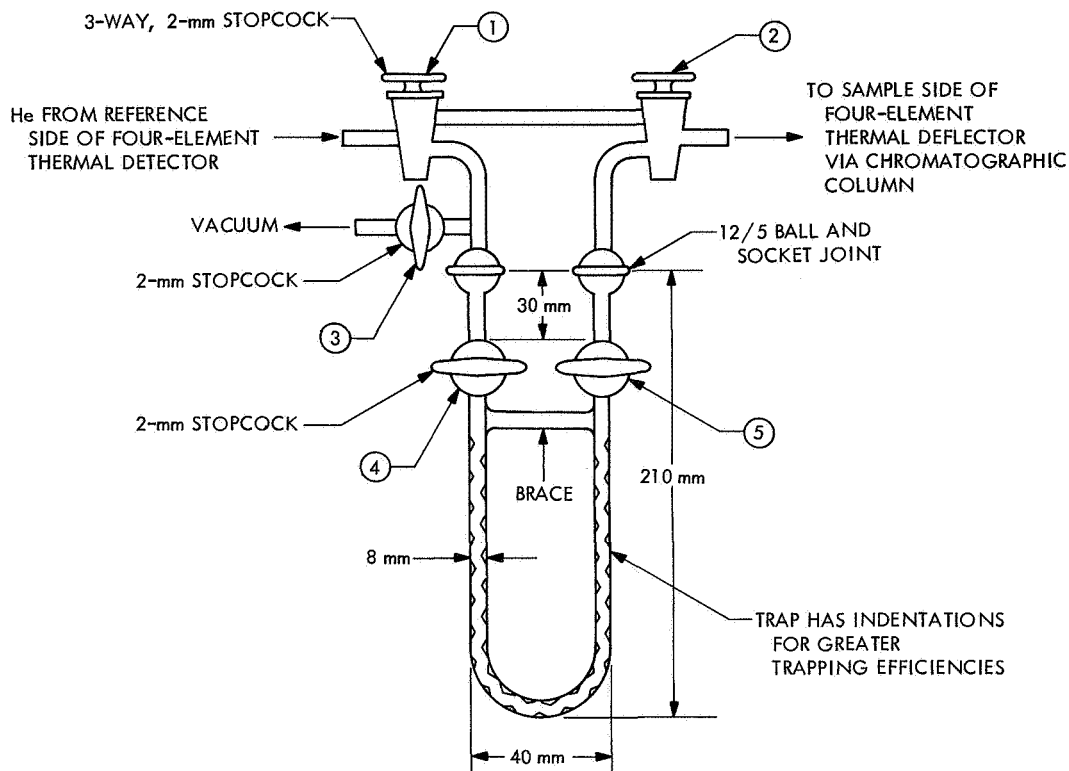

Fig. 8. Apparatus for connecting water trap to chromatographic column

- (3) The breaker is gently warmed by a heat gun as well as the interconnecting tubulation to facilitate removal of adsorbed water. Purging with helium is continued for about 15 min.
- (4) After 15 min, stopcock 6 and those in the previously purged trap are turned to flow helium through the whole system and out through the bubbler. The helium flow as read in a flow meter is set at 50 cm³/min.
- (5) After 15 min of more purging, the trap designated as 9 in Fig. 6 is immersed in dry-ice acetone with helium flow continued for 40 min. The water collected in this 40-min interval represents the blank water and is subtracted from that obtained with the sample.
- (6) The trap with the blank water collected in the 40-min interval prior to breaking the bulb is removed and replaced with another water-free trap. The stopcocks on the replacement trap are opened and helium flowed through for about 5 min, after which time the trap is immersed in dry-ice acetone and the sample in the breaker unit frozen with liquid nitrogen.
- (7) The sample bulb with the frozen sample is broken and the liquid nitrogen is removed so that the sample may thaw and vaporize. After about 20 min, the sample is vaporized; and, to drive over the sample completely, the breaker is rather strongly heated with a heat gun. Another 20 min of purging with helium is allowed with slight warming of an interconnecting tabulation before removing the sample trap and immediately replacing it with another which is purged with helium at ambient temperature in preparation for the next run.
- (8) The water in the sample trap is kept frozen by placing the trap into liquid nitrogen. The sample trap is quickly attached to the glass assembly shown in Fig. 8 after removal of the attached trap. At this time the helium flow through the trap loop is bypassed. The attached trap still immersed in liquid nitrogen is evacuated by opening stopcocks 3, 4, and 5. After reaching a pressure of 50 μm or less, stopcocks 3, 4, and 5 are closed, the trap is warmed up by a heat gun, and the thawed and vaporized water is sent through the column by proper manipulation of the necessary stopcocks.

- (9) The sensitivity for water is established by weighing-out water in sealed capillaries and running in the same manner as the samples.

The weight of water obtained from a sample is calculated from the integrated area of water peak corrected for a blank. The percent is calculated as follows:

$$\% \text{ water} = \frac{(\text{area for sample} - \text{area for blank}) \times S \times 100}{\text{weight of sample}} \times \left[1 + \frac{\% \text{ NO}}{187.5} \right]$$

where S is the sensitivity expressed as g of water per unit area.

If the oxidizer sample is nitrogen tetroxide and not MON-10, the second term in the above equation does not apply.

Results by the above method are reproducible to $\pm 0.005\%$ water absolute on samples containing approximately 0.10% water.

Note: In a cooperative effort with Dr. Stanley L. Manatt of JPL, the water in nitrogen tetroxide has been successfully run by NMR. The samples of nitrogen tetroxide were transferred into NMR tubes with 1/8-in. OD attached tubulations using the same technique as for filling sample bulbs. The NMR was calibrated by means of nitrogen tetroxide containing known additions of water. These standards were prepared from purified nitrogen tetroxide rendered anhydrous with phosphorus pentoxide. All manipulations, additions, etc., were made in a closed glass system previously heated and evacuated to eliminate extraneous water as much as possible. The NMR technique, once permanent standards were prepared, was rapid and rather precise. The NMR water results were reproducible to $\pm 0.005\%$ absolute on duplicate samples and $\pm 0.001\%$ for repeat runs on any one sealed sample. Agreement between the two methods was $\pm 0.01\%$ absolute.

VI. Nitrosyl Chloride

The method for the nitrosyl chloride on properly sampled nitrogen tetroxide is that of Mil-P-27408 (USAF), July 31, 1964.

VII. Ash

The ash can be determined in the sample remaining from the nitric oxide determination. The flask is reweighed after withdrawing all other samples so that the weight of sample left is known. The sample is transferred into a tarred platinum dish; the contents are evaporated at ambient or slightly elevated temperature and then treated with several drops of 15% sulfuric acid solution and heated on a hot plate to drive off the sulfuric acid. The platinum dish is ignited at 800°C, cooled, and reweighed. After weighing the platinum dish, the residue is again treated with several drops of 15% sulfuric acid, the acid evaporated on the hot plate, and the dish ignited, cooled, and reweighed. This procedure is repeated until a constant weight is obtained. This technique leaves the alkali metals as sulfates, and the metals of the iron group as oxides. Usually the total ash content is well below 0.05%, the upper limit set for alkali metals. This means that alkalies weighed as sulfates could be as high as 0.15% and still have an alkali metal constant below the 0.05% limit. With such low ash results, we have never found it necessary to determine the composition of the ash. If a very unusually high ash were found, then spectrographic, atomic absorption, colorimetric, and other techniques would need to be utilized.

$$\% \text{ ash} = \left(\frac{\text{weight of ignited residue}}{\text{weight of sample}} \right) \left(1 + \frac{\% \text{ NO}}{187.5} \right)$$

If the sample is nitrogen tetroxide and not MON-10, the second term does not apply.

VIII. Conclusion

The techniques described eliminate or minimize the shortcomings in sampling oxidizers as generally executed. The technique for assaying nitrogen tetroxide in which the nitrogen tetroxide is completely oxidized to nitric acid permits more accurate end points than in techniques where a mixture of weak and strong acid are titrated. The described technique also eliminates any dissolved carbon dioxide which might be present in the oxidizer. Carbon dioxide is not reported as nitrogen tetroxide. The method for water is based on a rigorous non-empirical method, and by incorporating the gas chromatographic technique, higher precision and specificity are achieved.