

PRECEDING PAGE BLANK NOT FILMED.

N 69 11813

Mechanical Suspensions for Space Applications

George G. Herzl
 Lockheed Missiles & Space Company
 Sunnyvale, California

Mechanical suspensions may be preferable to bearings for space applications because of the absence of wear, backlash, lubrication requirements, and other factors. Such factors as temperature changes, magnetic and electric fields, and force fields may cause instability in suspensions and must be considered in design. Major types of suspensions (torsion, filar, flexure, coil, and combinations) are described, with examples of use. Characteristics of mechanical suspensions are summarized in tabular form.

I. Introduction

Designers are increasingly using mechanical suspensions, where they previously used bearings, to support moving components of aerospace mechanisms. Mechanical suspensions have demonstrated a capacity to operate continuously for millions of cycles. Such long life is predictable because of the absence of wear, backlash, lubrication requirements, and other operational variables. As a means of providing long life in the space environment, mechanical suspensions can be preferable to even very-low-friction bearings (of comparable weight, volume, and complexity).

To help the designer choose between bearings and suspensions, their basic characteristics are compared in Table 1.

Table 1. Basic characteristics of bearings and suspensions

Component	Action	Motion	Restoring torque
Bearing	Rolling, sliding	Continuous rotary	Absent
Ball	↓	↓	↓
Roller			
Journal			
Conical pivot			
Suspension	Bending, twisting	Oscillatory	Present
Torsion	↓	↓	↓
Filar			
Flexure			
Coil			
Membrane			

One characteristic of mechanical suspensions, namely, restoring torque (due to bending or twisting motion that accommodates rotation of the suspended part), rules them out for continuous-rotation applications. For many other applications, however, they are the best choice. This paper discusses their advantages, as well as some design implications. Table 2, at the end of the paper, gives characteristics of the most common suspensions, along with equations to help the designer select the type best suited to his purpose.

II. Design Advantages of Suspensions

For aerospace applications, including various ground-based simulating devices, the advantages of mechanical suspensions are:

- (1) The absence of contacting surfaces precludes cold welding in the hard vacuum of space.
- (2) Shock mounting can be done fairly easily to protect against the rigors of launch, reentry, and explosive disturbances.
- (3) Components are ordinarily made from radiation-resistant material.
- (4) Lubricants and seals are not required.
- (5) High electrical conductivity can be maintained between stationary and rotating parts of the suspension.
- (6) Break-away torque is low because internal friction of materials replaces sliding or rolling friction encountered in bearings.

III. General Considerations

The most commonly used types of suspension are:

- (1) Torsion.
- (2) Filar.
- (3) Torsion and filar composite.
- (4) Flexure.
- (5) Coil.

- (6) Membrane.
- (7) Combination.

The torsion and filar (and their composite) types are further classified as single and double. Single — a suspension at only one end of the supported part — can be used in stationary devices where gravity can keep the suspension taut, as in orbital simulating devices. Spaceborne mechanisms employ double suspensions, since these can operate satisfactorily in any position and in an environment subject to shock and vibration.

To select an appropriate type of suspension, the designer should consider the following factors:

- (1) Required angle of rotation.
- (2) Type of restoring torque (positive, negative, or neutral; linear or nonlinear).
- (3) Available space.
- (4) Permissible axial motion.
- (5) Constancy of restoring torque.
- (6) Accuracy of null position.

The first four design considerations listed above are covered in Table 2 and in the following discussions of the various types of suspension. The last two, constancy of restoring torque and accuracy of null positioning, determine suspension stability and can be adversely affected by certain environmental factors and material characteristics, as discussed in detail in the following section.

IV. Designing for Maximum Suspension Stability

The designer must be aware of any factors that could cause instability, such as temperature changes, magnetic and electric fields, force fields, and other adverse factors. The geometry of a suspension may also affect its stability.

A. Temperature Changes

The effect of temperature changes on the restoring torque and the null positioning of mechanical suspensions is primarily a function of material characteristics. In designing for maximum stability, therefore, the designer must take into account the material characteristic most vulnerable to temperature-induced degradation in

each type of suspension. The following list shows this relationship:

Type of suspension	Material characteristic most affected by temperature changes
Torsion	Shear modulus
Filar	Thermal expansion
Flexure	Modulus of elasticity
Coil	Modulus of elasticity
Torsion and filar (or other) combination	Combination of characteristics above

Some techniques that minimize the effects of temperature changes on the stability of mechanical suspensions are as follows:

- (1) Subjecting the suspension elements to many cycles of pulsating temperature variations and subsequently annealing them to eliminate stress concentrations and invisible kinks. (For severe thermal operating environments, the pulsation should simulate actual conditions; for example, the abrupt and extreme temperature changes encountered when a satellite passes from the sunlit to the shadowed side of the earth.)
- (2) Using filament materials with low coefficients of expansion.
- (3) Using a different material for each filament, in order to provide a self-compensating feature (typical of early clock pendulums).
- (4) Using bimetallic compensating components to regulate tension in the suspension.

B. External Magnetic and Electric Fields

Torque constancy – a critical factor when a mechanism is involved in the measuring of extremely small forces – can be enhanced by employing materials that are not sensitive to magnetic or electric fields, by ensuring appropriate processing during manufacture of components, and by providing shielding.

C. Force Fields

If the instrument must operate in an unusual force field, such as those encountered during launch, on a

rotating platform, or in the weightlessness of space, the instrument must be dynamically balanced.

D. Other Adverse Factors

Certain material characteristics and certain other phenomena can have deleterious effects upon suspension stability. These include the following:

- (1) Inelastic creep of suspension material.
- (2) Internal friction, particularly of woven filaments.
- (3) Aging of suspension material.
- (4) Protective coatings (multiple coatings in particular).
- (5) Associated functions (for example, damping of oscillations may produce such effects as asymptotic return to zero position).

E. Geometry and Stability

Suspension stability is also related to the geometry of its parts. To improve stability, inherently null-stable geometries may be incorporated. A filar configuration, for example, can be made more null stable by separating the filaments at either end (or both ends) of the suspension. However, the possible effects of such alterations on other design parameters such as spring rate or shock resistance must be considered. The introduction of revised geometries should be subject to results of trade-off studies of the particular design.

V. Suspension Characteristics

The types of suspension discussed below include torsion, filar, flexure, coil, and combination.

A. Torsion Suspension

This type consists of one or more taut wires of an elastic material. Round wire is commonly used because it permits maximum twist for a given material. Other cross sections can be used if there is need for greater resistance to bending in a particular direction. Table 2 shows characteristics for elliptical as well as round torsion wire; for other configurations, see Ref. 1.

The restoring torque of torsion suspensions is always positive (increase in torque corresponds to increase in angle of twist) but can be made extremely small by using thin synthetic strands or woven thread as the suspension

filament. The relation of torque to twist is linear for relatively large angles of twist. Variation in filament tension affects the restoring torque indirectly by producing, under proper design circumstances, only minute changes in filament diameter.

A practical application of torsion-wire suspension is a magnetic hysteresis damper (Fig. 1) used on satellites

The Nomenclature section applies to the figures as well as to Table 2.

oriented by gravity-gradient effect to dampen vibrations during orbit (Ref. 2). Typically, such a double torsion suspension uses high-strength steel wire 2 in. long and 0.008 in. in diameter, with a torsional spring rate of 0.36×10^{-3} ft-lb per radian. The damper consists of two units affixed to each other at right angles. Each unit is free to rotate 60 deg in either direction from the null position. Tension adjustments are provided at the ends of the suspensions to keep the wire taut and preclude axial motion of the suspended parts under a wide range of operating temperatures.

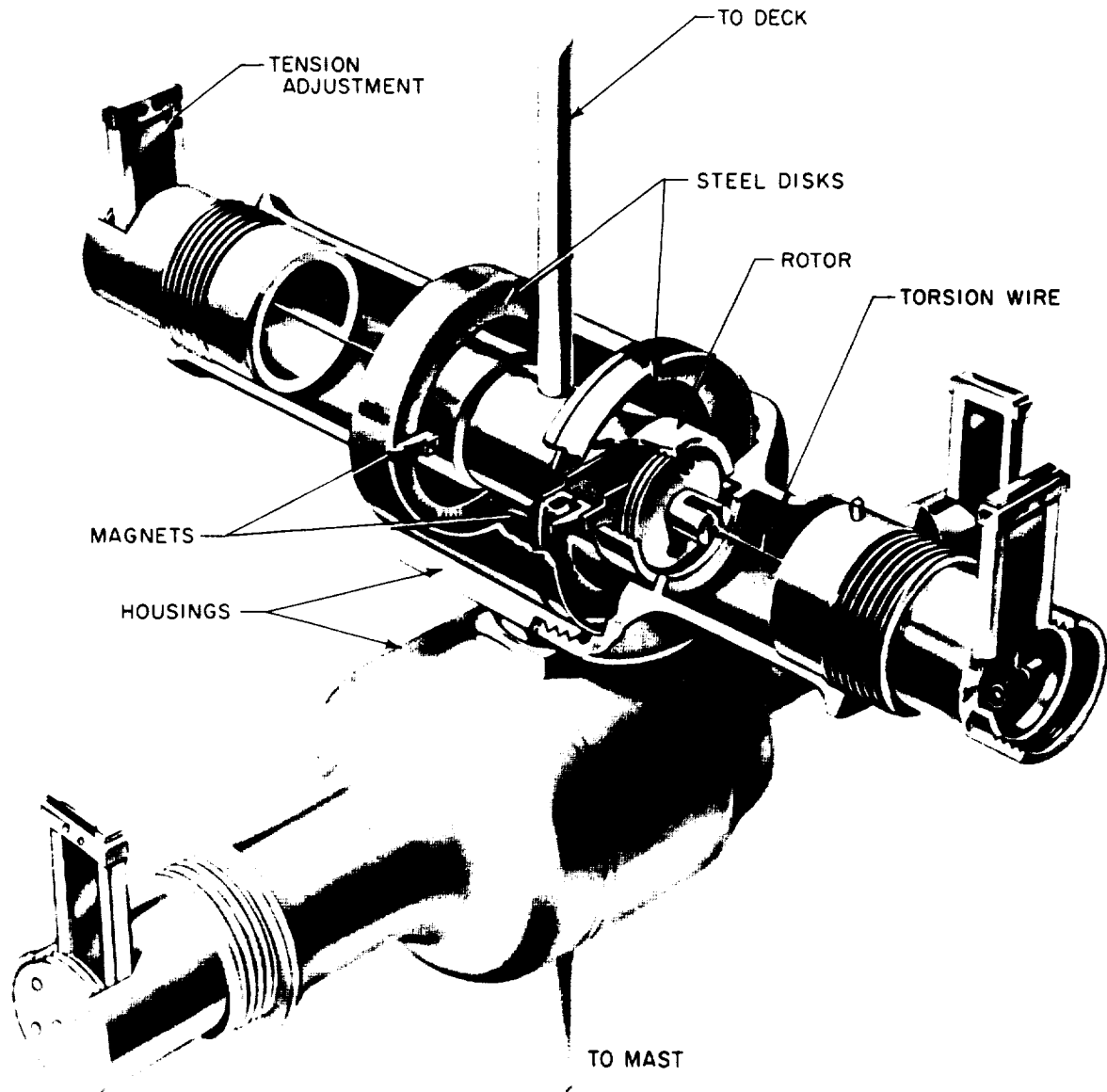

Fig. 1. Torsion-wire suspension used in magnetic hysteresis damper. Each unit contains a double suspension and each is free to rotate 60 deg in either direction from the null position (photograph courtesy of American Telephone and Telegraph Co.)

B. Filar Suspension

Filar suspension employs filament sets consisting of two or more filaments each, the number of sets varying according to design requirements. If parallel motion of the axis of the suspended part is required, a two-set (bifilar) configuration is employed on each side of the part. If parallel motion of the entire configuration is required, a three-set (trifilar) configuration is used on each side. More than three sets are seldom used, except to double as carriers of electricity to a suspended part requiring several connections. Several filar configurations are shown in Fig. 2.

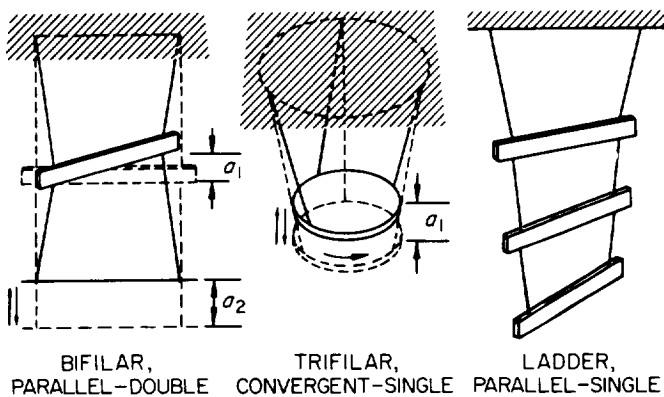

Fig. 2. Typical filar suspension configurations

Accuracy of null positioning and easy adjustment of restoring torque are special advantages of the filar configurations. For a comprehensive discussion of the filar technique, see Ref. 3.

The restoring torque in filar suspensions is derived primarily from tension in the filaments. In filaments of finely woven thread without resistance to torsion and bending, restoring torque is proportional to the sine of the angle of rotation. (The data in Table 2 are based on this assumption.) Fine wire with some elasticity can be used, but the effect of the elasticity on restoring torque must be considered.

Elements of the filar suspension are located along the axis of rotation. Provision must be made for one or both ends to be free to move because of inherent axial motion of the suspension elements. This effect, largest when one end of the suspension is fixed, can magnify motion by converting small axial motion into relatively large rotation.

C. Torsion and Filar Composite Suspension

This type, made up of two or more taut strips side by side, derives its restoring torque from the combined effects of the filar configuration and torsional stress. Composite suspensions can attain better null-positioning accuracy than that provided by torsion suspension alone, while avoiding some of the complexity of the all-filar suspension.

D. Flexure Suspension

This suspension consists of a flat spring supporting a rotating part. The most common configurations are single-strip, two-strip, and three-strip (Fig. 3). They differ mainly in complexity; capability to provide very low, zero, and negative spring rates; and amount of motion of the center of rotation as a function of load and angle of twist.

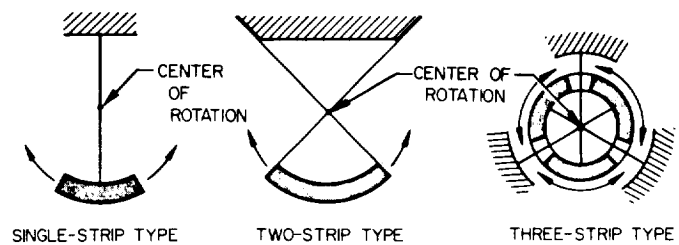

Fig. 3. Flexure suspensions (flat springs that support a rotating part). Three types are shown

1. *Single-strip type.* This configuration has been used for more than a century for suspending pendulums in grandfather clocks. In practice, single-strip flexure suspensions are used only for positive spring rates. The center of rotation changes with angular deflection and load.

2. *Two-strip type.* This type is finding such aerospace applications as suspensions for missile control nozzles and a wide range of ultraprecision spaceborne instruments — from gyroscopes to large telescope assemblies. An external tension load to the strips can produce very low, zero, or negative spring rates; this change of spring rate should be considered in the design of devices that operate in the weightlessness of space but are to be tested on the ground. The location of the center of rotation changes with angular deflection and load by a smaller amount than in single-strip suspension. A two-strip configuration, in which one of the strips has been divided for increased lateral rigidity, is shown in Fig. 4.

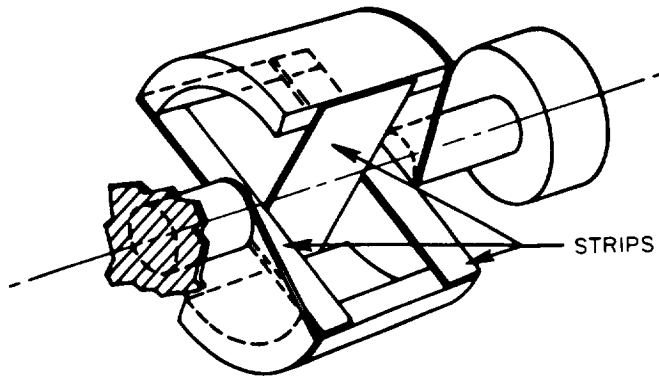

Fig. 4. Two-strip flexure suspension with one strip in one axis and two in the other axis

A recent use of two-strip flexure suspension was one that the author suggested, and NASA adopted, for supporting a telescope mount weighing several tons in an Apollo spacecraft originally scheduled for 1968 launch (Fig. 5). This suspension, employing four flexure pivots, makes possible an extremely precise pointing capability because of its low breakaway torque. It also satisfies the requirement for long service life in a hard-vacuum environment and eliminates the hazard of optical contamination that would be posed by the use of a lubricant on bearings.

3. *Three-strip type.* This complex type is the most versatile of the flexure suspensions. It is adjustable to provide either positive, zero, or negative restoring torques

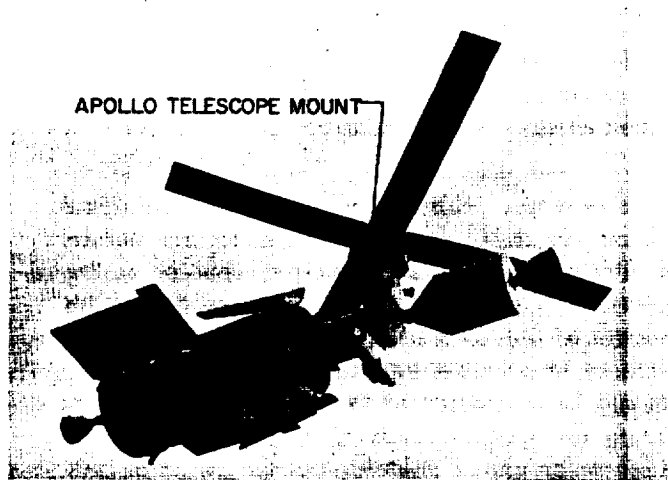

Fig. 5. The Apollo Telescope Mount (ATM) supported on two-strip flexure suspension — a systems concept suggested by the author

even when there is no external load. In theory, deflection of the suspended part does not affect the center of rotation. However, strip misalignment does cause a slight shift of the null position and some motion of the center of rotation when the suspension deflects, and these effects should be taken into account in high-precision designs.

The formulas given in Table 2 for restoring torque assume no axial forces acting on the flexure suspension; for a discussion of other cases, see Ref. 4.

E. Coil Suspension

Coil suspensions may be of the spiral or helical configurations. Spiral springs (Ref. 5), as a sole suspension element, are used only for lightweight parts (Fig. 6). This type is commonly used with very-low-friction bearings, such as conical-pivot bearings (Fig. 7), which limit lateral motion of the suspended part and absorb axial thrust of gravity and shock.

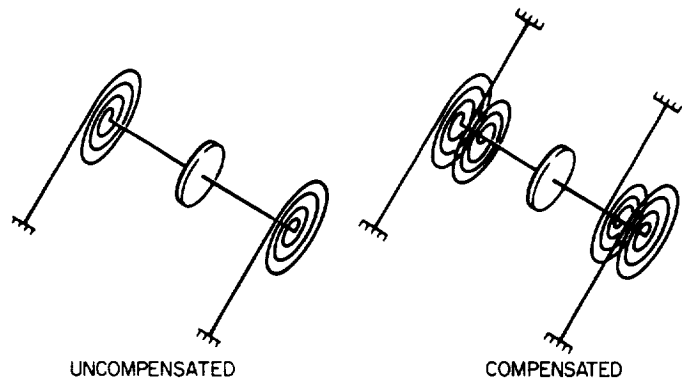

Fig. 6. Spiral spring suspensions

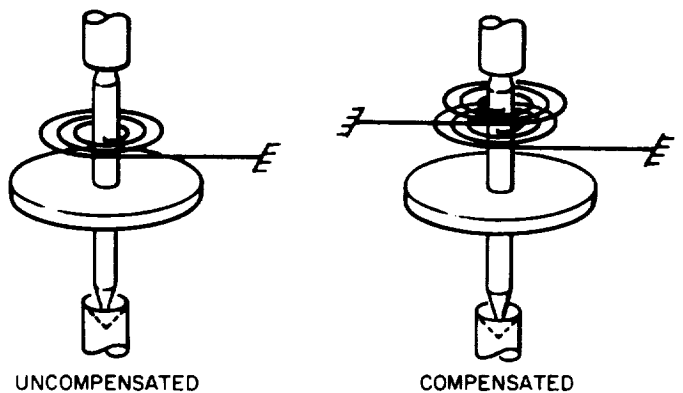

Fig. 7. Spiral spring suspensions with conical bearings

Thermal stability, often the most vital design consideration for aerospace mechanisms, can be improved by the use of pairs of matched, counter-wound, spiral springs; each tends to compensate for the thermal expansion of the other (see Figs. 6 and 7).

Spiral spring data presented in Table 2 apply to springs having many coils that do not touch. Stiffness can be increased by the use of a small number of coils (Ref. 6). Spring rate also increases when coils touch during operation.

Helical spring suspensions employ coiled elastic materials and provide six degrees of freedom to the suspended part (Fig. 8). Typical applications are shock mounts and isolation mounts. Calculation of restoring torques is complicated by the interaction of lateral and longitudinal forces and resulting torques; thus no simple relationships can be developed.

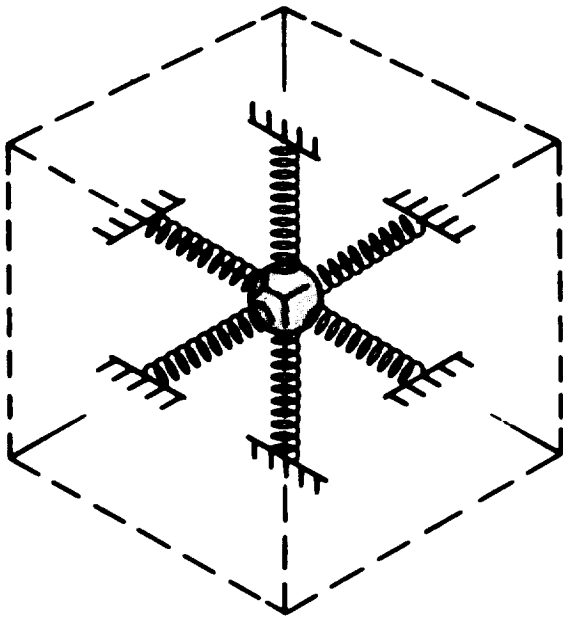

Fig. 8. Helical spring suspension. This type is most often used as a shock isolation mount

F. Combination Suspension

A design can sometimes combine two or more of the principal suspension types. A typical example is a combination of flexure and torsion (or filar) suspension. Such a combination provides a shock mounting for the delicate

wires of low-restoring-torque suspension (Fig. 1). Another example is the use of a bimetallic spring in place of the monometallic flat type to obtain a variable spring rate as a function of temperature. A combination that uses membranes in lieu of flexure suspensions is shown in Fig. 9.

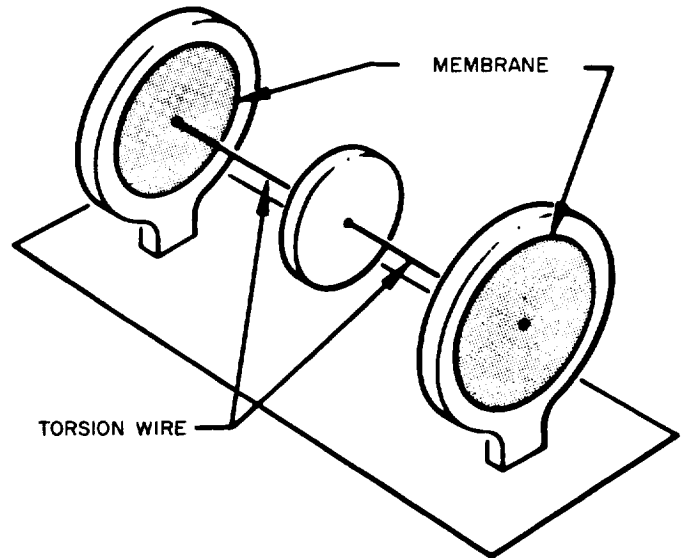

Fig. 9. Combined membrane and torsion-wire suspension

Still another example (Fig. 10) is a device which was designed to simulate quasi-static orbital conditions by providing oscillatory motions with periods of one hour or longer. It is basically a torsional pendulum having large inertia, which is acted upon by a low restoring torque. The restoring torque is provided mainly by the spiral spring, since the spring rate of the torsion wire is much smaller. Very small torques can be applied to the suspended assembly by rotating the end of the spiral spring attached to the rotary table.

VI. Summary

A summary of the characteristics of the most common mechanical suspensions is given in Table 2. Some comments to aid in interpreting the table are listed below.

In the first column of Table 2, "single" and "double" indicate whether the part hangs on a single suspension or is suspended at both ends. Equations for double-suspension types were developed on the assumption that both suspending elements are made of identical material.

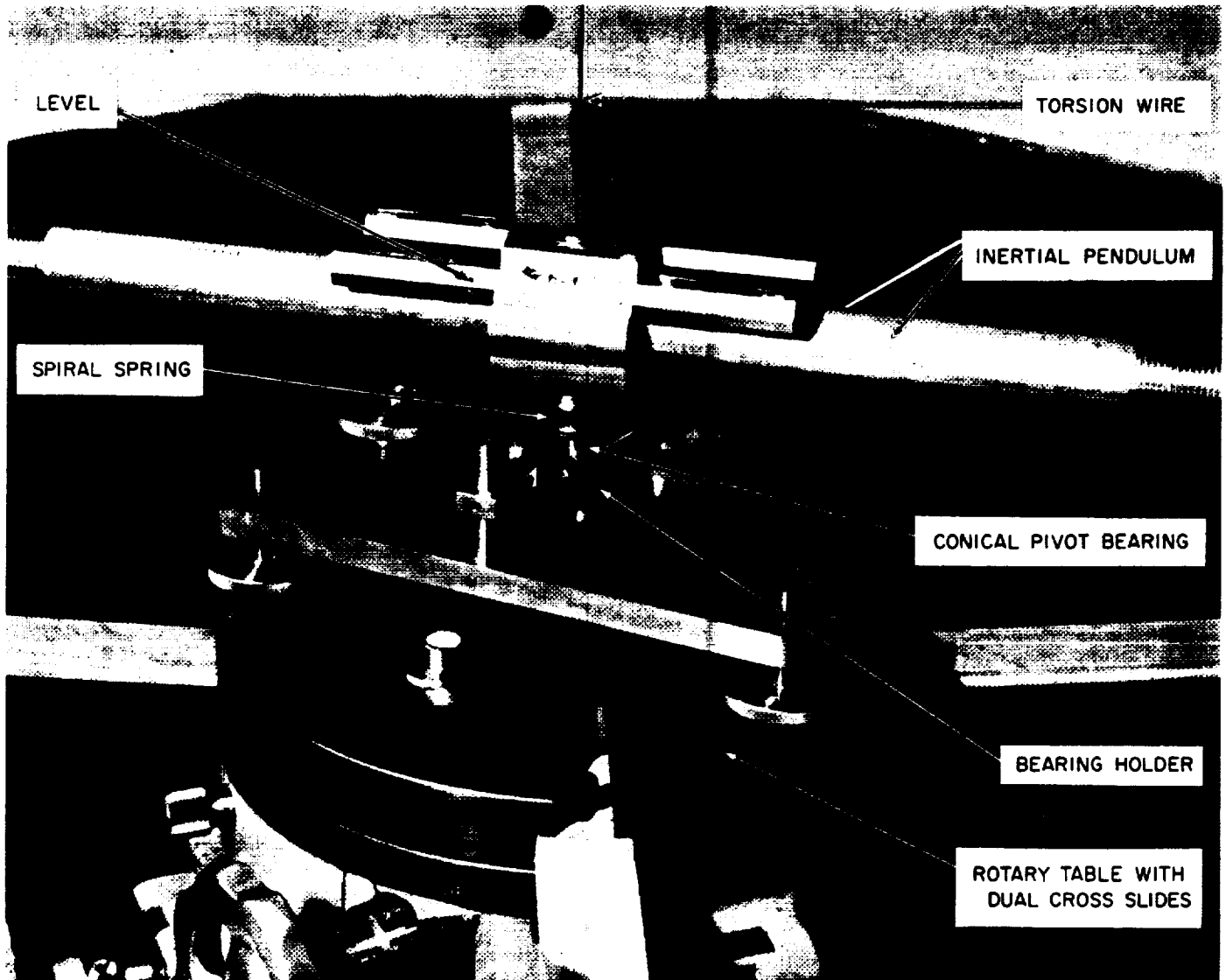

Fig. 10. Torsion wire and spiral-spring suspensions in an orbital simulator designed by the author (photograph courtesy of Philco-Ford Western Development Laboratories)

“Installation configuration” indicates whether the suspension elements are along the axis of rotation or in the radial direction.

“Source of restoring torque” shows only the principal source; the equations disregard secondary sources.

“Approximate permissible twist” values are indicative only of the range in which restoring torque is linearly proportional to deflection, and for which no permanent deformation occurs. These values should be used only for the initial selection of a suspension type, since actual

range can vary significantly with suspension complexity and configuration, required accuracy of null position, and restoring torque.

“Axial motion” refers to motion of the suspended part toward the fixed-suspension end; one end of the suspension is assumed to be fixed and the other able to move axially. (Axial motion of the part can be eliminated by providing for symmetrical motion of both ends of the suspension.)

“Null position accuracy” ratings indicate only the relative merit of each type.

Table 2. Characteristics of mechanical suspensions

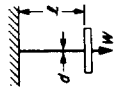
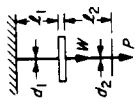
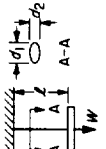
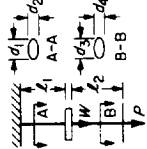
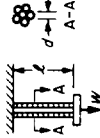
Type	Sketch	Installation configuration	Source of restoring torque	Restoring torque	Approximate permissible twist	Axial motion ^a		Null positioning accuracy ^b
						Suspended part	Moving end of suspension	
Torsion wire, circular cross section—single		Axial	Shear stress	$\frac{\pi}{32} G \frac{d^4}{l} \theta$	± 1 turn	$\frac{d^2}{16l} \theta^2$	—	B-C
Torsion wire, circular cross section—double		Axial	Shear stress	$\frac{\pi}{32} G \left(i_1 \frac{d_1^4}{l_1} + i_2 \frac{d_2^4}{l_2} \right) \theta$	± 1 turn	$\frac{d_1^2}{16l_1} \theta^2$	$\frac{1}{16} \left(\frac{d_1^2}{l_1} + \frac{d_2^2}{l_2} \right) \theta^2$	B-C
Torsion wire, elliptical cross section—single		Axial	Shear stress	$\frac{\pi}{16} G \frac{d_1^2 d_2^2}{d_1^2 + d_2^2} \frac{1}{l} \theta$	$\pm \frac{1}{2}$ turn	$\frac{1}{8l} \frac{d_1^2 d_2^2}{d_1^2 + d_2^2} \theta^2$	—	B
Torsion wire, elliptical cross section—double		Axial	Shear stress	$\frac{\pi}{16} G \left(\frac{d_1^2 d_3^2}{d_1^2 + d_3^2} \frac{1}{l_1} + \frac{d_2^2 d_4^2}{d_2^2 + d_4^2} \frac{1}{l_2} \right) \theta$	$\pm \frac{1}{2}$ turn	$\frac{1}{8l_1} \frac{d_1^2 d_3^2}{d_1^2 + d_3^2} \theta^2$	$\frac{1}{8} \left[\frac{d_1^2 d_3^2}{(d_1^2 + d_3^2) l_1} + \frac{d_2^2 d_4^2}{(d_2^2 + d_4^2) l_2} \right] \theta^2$	B
Torsion filament bundle—single		Axial	Shear stress	$\frac{\pi}{32} i G \frac{d^4}{l} \theta$	± 10 turns	$\frac{k^2}{2l} \theta^2$	—	C

^aAssuming one suspension-end to be fixed.

^bNull positioning accuracy ratings: C—good, B—very good, A—excellent.

Table 2 (contd)

Type	Sketch	Instal- tion config- uration	Source of restoring torque	Restoring torque	Approximate permissible twist	Axial motion ^a		Null posi- tioning accu- racy ^b
						Suspended part	Moving end of suspension	
Torsion filament bundle—double		Axial	Shear stress	$\frac{\pi}{32} G \left(i_1 \frac{d_1^4}{l_1} + i_2 \frac{d_2^4}{l_2} \right) \theta$	±10 turns	$\frac{k_1^2}{2l_1} \theta^2$	$\frac{1}{2} \left(\frac{k_1^2}{l_1} + \frac{k_2^2}{l_2} \right) \theta^2$	C
Bifilar and trifilar, nonparallel—single		Axial	Axial force	$\frac{1}{4} W \frac{D_1 D_2}{l} \sin \theta$	±90 deg (max)	$l - \left(l^2 - D_1 D_2 \sin^2 \frac{\theta}{2} \right)^{1/2}$	—	A
Bifilar and trifilar, nonparallel—double		Axial	Axial force	$\frac{1}{4} \left[(W + P) \frac{D_1 D_2}{l_1} + P \frac{D_3 D_4}{l_2} \right] \sin \theta$	±90 deg (max)	$l_1 - \left(l_1^2 - D_1 D_2 \sin^2 \frac{\theta}{2} \right)^{1/2}$	$l_1^2 + l_2^2 - \left(l_1^2 - D_1 D_2 \sin^2 \frac{\theta}{2} \right)^{1/2} - \left(l_2^2 - D_3 D_4 \sin^2 \frac{\theta}{2} \right)^{1/2}$	A
Bifilar and trifilar, parallel—single		Axial	Axial force	$\frac{1}{4} W \frac{D^2}{l} \sin \theta$	±90 deg (max)	$l - \left(l^2 - D^2 \sin^2 \frac{\theta}{2} \right)^{1/2}$	—	A
Bifilar and trifilar, parallel—double		Axial	Axial force	$\frac{1}{4} \left[(W + P) \frac{D_1^2}{l_1} + P \frac{D_2^2}{l_2} \right] \sin \theta$	±90 deg (max)	$l_1 - \left(l_1^2 - D_1^2 \sin^2 \frac{\theta}{2} \right)^{1/2}$	$l_1^2 + l_2^2 - \left(l_1^2 - D_1^2 \sin^2 \frac{\theta}{2} \right)^{1/2} - \left(l_2^2 - D_2^2 \sin^2 \frac{\theta}{2} \right)^{1/2}$	A

^a Assuming one suspension-end to be fixed.

^b Null positioning accuracy ratings: C—good, B—very good, A—excellent.

Table 2 (contd)

Type	Sketch	Instal- lation config- uration	Source of restoring torque	Restoring torque	Approximate permissible twist	Axial motion ^a		Null posi- tioning accu- racy ^b
						Suspended part	Moving end of suspension	
Bifilar and trifilar ladder, parallel— single		Axial	Axial force	$\frac{1}{4} W m \frac{D^2}{l} \sin \frac{\theta}{m}$	± 90 deg (max)	$l - \left(l^2 - m^2 D^2 \sin^2 \frac{\theta}{2m} \right)^{1/2}$	—	A-B
Bifilar and trifilar ladder, parallel— double		Axial	Axial force	$\frac{1}{4} \left[(W + P) m_1 \frac{D_1^2}{l_1} \sin \frac{\theta}{m_1} + P m_2 \frac{D_2^2}{l_2} \sin \frac{\theta}{m_2} \right]$	Smaller of ± 90 m ₁ and ± 90 m ₂ deg (max)	$l_1^2 + l_2^2 - \left(l_1^2 - m_1^2 D_1^2 \sin^2 \frac{\theta}{2m_1} \right)^{1/2} - \left(l_2^2 - m_2^2 D_2^2 \sin^2 \frac{\theta}{2m_2} \right)^{1/2}$	—	A-B
Filar and torsion composite, multistrip— single		Axial	Shear stress and axial force	$\left(\frac{1}{3} \frac{b^2}{n^2 l} + \frac{1}{12} \frac{b^2}{W l} \right) \theta$	± 30 deg	$k^2 \frac{\theta^2}{2l}$	—	A-B
Filar and torsion composite, multistrip— double		Axial	Shear stress and axial force	$\frac{1}{3} \left(\frac{b_1^2}{n_1^2 l_1} + \frac{b_2^2}{n_2^2 l_2} \right) G + \frac{1}{12} \left[(W + P) \frac{b_1^2}{l_1} + P \frac{b_2^2}{l_2} \right] \theta$	± 30 deg	$\frac{k_1}{2l_1} \theta^2$	$\frac{1}{2} \left(\frac{k_1}{l_1} + \frac{k_2}{l_2} \right) \theta^2$	A-B

^aAssuming one suspension-end to be fixed.

^bNull positioning accuracy ratings: C—good, B—very good, A—excellent.

Table 2 (contd)

Type	Sketch	Installation configuration	Source of restoring torque	Restoring torque	Approximate permissible twist	Axial motion ^a		Null positioning accuracy ^b
						Suspended part	Moving end of suspension	
Flexure, one strip		Radial	Bending stress	$E \frac{bf^3}{12l} \theta$	± 20 to 30 deg	≈ 0	—	A-B
Flexure, two strip		Radial	Bending stress	$E \frac{bf^3}{6l} \theta$	± 20 to 30 deg	≈ 0	—	A
Flexure, three strip		Radial	Bending stress	$E \frac{bf^3}{4l} \theta$	± 20 to 30 deg	≈ 0	—	A
Coil, spiral spring		Radial	Bending stress	$E_i \frac{bf^3}{12l} \theta$	± 1 turn	≈ 0	—	A-B

^aAssuming one suspension-end to be fixed.

^bNull positioning accuracy ratings: C—good, B—very good, A—excellent.

Nomenclature

<i>a</i>	axial motion, in.	<i>l</i>	length, in.
<i>b</i>	width of strip or coil, in.	<i>m</i>	number of steps of ladder suspension
<i>c</i>	diameter of wire or filament, in.	<i>n</i>	number of strips in multistrip suspension
<i>D</i>	diameter of suspension attachment, in.	<i>P</i>	external load, lb
<i>E</i>	modulus of elasticity, psi	<i>t</i>	total thickness of strip or of composite strip, in.
<i>G</i>	modulus of rigidity, psi	<i>W</i>	weight, lb
<i>i</i>	number of wires in strand	θ	angle of deflection, deg
<i>j</i>	number of spiral springs in suspension		
<i>k</i>	radius of gyration, in.		Subscripts 1, 2, 3, 4 refer to parts of suspensions.

References

1. Chironis, N. P., *Spring Design and Application*, p. 141, McGraw-Hill Book Co., Inc., New York, 1961.
2. Paul, B., West, J. W., and Yu, E. Y., "A Passive Gravitational Attitude Control System for Satellites," *Bell Syst. Tech. J.*, Vol. 42, No. 5, p. 2204, Sept. 1963.
3. Geary, P. J., *Torsion Devices*, British Scientific Instrument Research Association, 1954. (Extensive bibliography lists other references.)
4. Weinstein, W. D., "Flexure-Pivot Bearings, Part 1," *Machine Des.*, Vol. 37, No. 13, June 10, 1965; "Part 2," Vol. 37, No. 16, July 8, 1965.
5. Wahl, A. M., *Mechanical Springs*, Second Edition. McGraw-Hill Book Co., Inc., New York, 1963.
6. Kroon, R. P., and Davenport, C. C., "Spiral Springs With Small Number of Turns," *J. Franklin Inst.*, Vol. 225, p. 171, 1938.

Selected Bibliography

- Herzl, G. G., "How to Design for Minimum Torque in Pivot Bearings," *Machine Des.*, Vol. 37, No. 28, pp. 146-152, Dec. 9, 1965.
- Herzl, G. G., "Conical Pivot Bearings for Space Applications," *Proceedings of the First Aerospace Mechanisms Symposium*, University of Santa Clara, Santa Clara, Calif., May 1966.
- Herzl, G. G., "Instrument Suspensions," *Machine Des.*, Vol. 39, No. 2, pp. 182-191, Jan. 19, 1967.
- Herzl, G. G., "Theory of Flexure Pivot With Displaced Center of Rotation," to be published in *Machine Des.*

PRECEDING PAGE BLANK NOT FILMED.

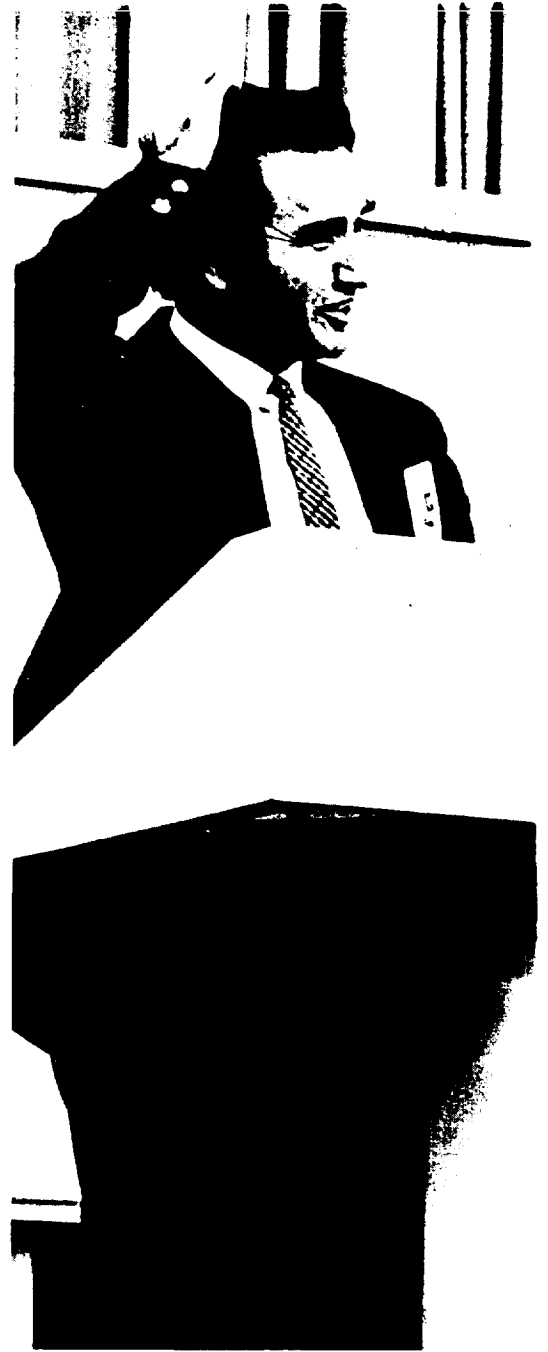

Session III

Preceding page blank

OVERLEAF: *Bernard Roth, Stanford University, Session Chairman*