

General Disclaimer

One or more of the Following Statements may affect this Document

- This document has been reproduced from the best copy furnished by the organizational source. It is being released in the interest of making available as much information as possible.
- This document may contain data, which exceeds the sheet parameters. It was furnished in this condition by the organizational source and is the best copy available.
- This document may contain tone-on-tone or color graphs, charts and/or pictures, which have been reproduced in black and white.
- This document is paginated as submitted by the original source.
- Portions of this document are not fully legible due to the historical nature of some of the material. However, it is the best reproduction available from the original submission.

ABSTRACT

On February 13, 1967 at 1746 UT, the brightest flare of that year erupted from the surface of the sun. Approximately 56 hours later, the sudden commencement of a magnetic storm was recorded by many observatories around the world. Midway between the worldwide sudden commencement and the termination of the magnetic storm, there occurred at Ft. Churchill an aurora attaining nearly IBC III and an accompanying local negative magnetic bay. Measurements were made on this aurora as one of a series investigated with a multiple channel photometer simultaneously recording ten wavelength bands.

The aurora of February 16 appeared normal under casual observation, but a detailed examination of its emission structure has turned up a number of deviations from other aurorae studied. Highlights of these include an unusual amount of $\lambda 6300$ intensity and an increase in the apparent vibrational temperature of the molecular nitrogen that correlates well with the increase in the $\lambda 6300$ emission. It is concluded that the magnetic storm is primarily responsible for these unusual effects.

INTRODUCTION

On February 13, 1967 at 1746 UT, the onset of a solar flare was recorded at the Sacramento Peak Observatory. During the ensuing 4 hours of its lifetime, the flare was noted at five additional stations and a Geophysical Alert was issued at 1900 UT. Estimates of the importance of this solar flare, which was given the group number 3383, varied from 2F to 4B. The ultimate normalized value was set at 3 (on the 1- to 3+ scale). On February 15, 1967, a magnetic storm began at 2348 UT and continued for a day or more (ESSA).

At the time of flare 3383, the present investigators were conducting a ground-based study of the aurora at Ft. Churchill in close cooperation with a combined ground and rocket effort under the direction of W.G. Fastie of the Johns Hopkins University. The widespread reporting of the flare and the associated events led to the issuance of magnetic storm alerts no. 473 on February 14 and no. 474 on February 15. The transmissions containing this information reached Ft. Churchill during a period when the weather was particularly adverse from the point of view of field operations (ESSA). The management of the Churchill Research Range, in response to the various alerts and the

importunings of several investigators, made special arrangements to open the range on the night of February 14. Auroras attaining IBC III were recorded on the nights of both February 14 and 15; the Johns Hopkins rocket (NASA 4.163UA) was counted on the 15th and 16th and fired on the latter night. The present work concerns ground-based auroral data collected on the night of February 15, 1967 (0800 UT, February 16).

In the course of the field trip during which the visual aurora under discussion occurred, some 20 hours of auroral data were collected, reduced, and studied. The 3 minutes of data which will be presented and discussed below was recorded during an aurora which was in no way remarkable in its visible aspects. Neither was it by any means the brightest aurora measured nor the longest in duration. It did, however, have characteristics which set it apart from all other displays, bright or dim. Such a departure would seem to imply either an unusual conditioning of the ionosphere prior to the excitation of the auroral emissions or a special bias to the excitation process itself during the onslaught of the magnetic storm.

Accordingly, it has seemed appropriate to present a selection of data concerning the solar flare and the resulting magnetic storm. The intent is to supply the

information relevant to the primary and secondary processes leading to the aurora under consideration. Thus, results of measurements concerned with the overall variation of the geomagnetic field are presented as well as data derived from more local phenomena in the auroral zone. The latter, including magnetometer traces, riometer absorption readings, and visual observations, serve to relate the auroral emission data to the condition of the ionosphere where the auroral arc is produced.

SOLAR-GEOPHYSICAL DATA

The flare in question, assigned the second highest normalized importance classification on the 1- to 3+ scale, was one of the largest in recent years. Observations by the Sacramento Peak station indicate that it covered an area of 38.68 square degrees in the northwestern (N 21.7 W 10.1) region of the sun, began at 1746 UT, peaked at 1816 UT, and ended at 2234 UT with a total duration of 296 minutes. Associated with the region of origin of the flare were two sunspot groups with an area covering one millionth of the solar hemisphere (ESSA). The sudden commencement due to the arrival of the shock wave front from this solar flare was recorded at about midnight on February 15, UT, so that the mean velocity of the shock can be computed to be about 800 km/sec, assuming the baseline of travel to be one A.U. (L. Harang, 1968; Ogilvie, Burlaga, and Wilkerson, 1968).

To aid in the determination of the effects of the solar flare upon geophysical parameters, three indicators are available that are sensitive to activity in the solar wind: cosmic rays, radio disturbances, and the planetary magnetic index (ESSA). Figure 1 presents the plots of these data for the month of February, 1967. There is no reason to doubt that the 6.5 percent Forbush decrease in the cosmic ray indices, the sharp rise in the K_p index

and the deterioration in the radio reception all appearing on February 16, are indicative of a magnetic storm, the origin of which was the solar flare of February 13. It should be noted that the magnetic storm effects began at about 0001 UT and continued to increase up to 0800 UT before the long recovery process began to take effect.

The upper two thirds of Figure 2 show two traces of the activity for the horizontal component of the earth's magnetic field for Ft. Churchill and Fredericksburg, Virginia; the lower third displays the riometer data taken by the Ft. Churchill Auroral Observatory. The time along the horizontal axis is divided into units of Universal Time for all traces with each trace having its own vertical scale. The sudden commencement came at about midnight UT as indicated by the upward jump on both the Virginia and Churchill traces. Neither trace exhibits a negative bay until 0800 UT, when the Churchill trace decreases about 120 gammas but the Virginia trace presents no such response. In other words, there is a local anomaly superimposed upon the magnetic field at Ft. Churchill which is of the type that occurs regularly in the auroral zone at night. After 0800 UT the Churchill trace had begun to recover from the negative bay when the onslaught of the magnetic storm

upon the local magnetic field begins leading to the development of two further overlapping negative bays. The Virginia trace shows similar signs of disturbances with some degree of correlation, particularly at 0900 UT. During the same time interval, the riometer data ignores the negative bay of the Churchill trace that came at 0800 UT but responds to the effects of the storm that came later (in particular, it shows the effect of the drastic decrease in the X-component of Churchill at 0900 UT). The antenna for this particular recording of the galactic radio noise was directed towards the North Star (30 degrees from the zenith) but the spread of the acceptance cone is sufficient to include the zenith. Hence, the failure of the riometer to respond to the excitation and production of the auroral band would seem to indicate the lack of high energy electrons greater than 25 kev (B. Hultqvist, 1966).

BRIEF DESCRIPTION OF INSTRUMENTATION

A ten channel filter-wheel photometer, continuously rotating at ten hertz, was installed in the eastern dome outside of the Ft. Churchill Auroral Observatory. The output of this instrument was collected on five Brush strip-chart recorders that registered two channels each via analog pens and, in addition, the time from WWV via the event marker pens.

Figure 3 is a simplified drawing of the probe unit of the photometer. The lower portion of the figure shows the telescope tube with the lens at the left, the tripod mount at the bottom, and the motor drive and photomultiplier housing at the right. The upper portion of the figure gives an end-on view which serves to relate positions of the ten filters, the telescope tube, and the photodiode timing pulse generator.

Omitted from Fig. 2 in the interest of simplicity are a long lens hood which extends to the left nearly a lens tube length and the signal conditioning electronic gear which is located above the photomultiplier housing. The lens hood, although a simple physical extension of the telescope, is quite an important feature of the instrument since it is sufficiently effective to permit

measurement of night sky and auroral emission through a ceiling window in a lighted room.

The ten spectral windows chosen for simultaneous observation in the present photometer (see table) included 3710A, 3757A, and 3807A as a subset for investigation of the vibrational development of the $C^3\Pi_v$ of N_2 as manifest in the $\Delta v = -2$ sequence of the 2PG. In the red, the three bands 6680A, 6770A, and 6850A serve, similarly, to delineate the vibrational development of the $B^3\Pi_g$, here emitting the 1PG with $\Delta v = 3$. The forbidden green and red lines of atomic oxygen at 5577 and 6300A, respectively, and the N_2^+ ING band at 3914 were also observed. The final filter in the group of ten isolates a rather broad spectral band near 5715A which was chosen as being relatively remote from strong auroral emissions. This moonlight (or background) channel is very useful for monitoring the various continuous emissions and scatterings which constitute the base from which the auroral features are to be measured.

Filter band widths varied from 11 to 55A with the narrowest being that which isolated the 6300A line and the broadest the 1PG band at 6850A. The average value of the band width for the 2PG set of filters is about 25A and, similarly, about 55A for the 1PG set.

THE EMISSION FEATURES OF THE VISUAL AURORA

The photometer was employed in two general modes during auroral observations. Where efforts were being made to coordinate with rocket experiments, the photometer would be directed successively at the two intersections of the rocket trajectory with the 100 km plane. Otherwise, the procedure was simply to align the instrument vertically for continuous observation of the zenith so that atmospheric extinction and scattering effects might be minimized. Typically, observation began in the early evening hours and continued until the possibility of a further break-up was judged to be small.

For the particular night under consideration, the common auroral emission features had remained relatively quiescent although 6300A showed considerable activity all evening. At 0800 UT the photometer picked up the emissions from the leading edge of an IBC III band, which according to the visual observation charts, was moving southeasterly aligned in the east-west direction. Unfortunately, there are no available all-sky photographs of the Ft. Chruhill area for the period of interest so that it is not possible to distinguish strictly between spatial and temporal fluctuations. However, during the

course of the passage of the band, there seems to have been two major pulses: the first pulse extending from 25 kilorayleighs (KRS) to 87 KRS of 5577A and then about 50 seconds later, the second pulse ranging from 25 KRS to 60 KRS of 5577A. It would appear, then, that there were two major spatial components in the band with the region between filled in with a base of 25 KRS. The time behavior of this aurora could hardly be characterized as "steady". Thus, since much of the concern of the present study lay in the area of relationships between the intensities of the various auroral emissions, considerable effort was expended in the reduction, scaling, and analysis of the data, particularly with respect to questions of simultaneity and intensity calibration.

In the initial phase of the data reduction the deflections on the strip chart recordings were digitized by hand to an amplitude resolution of one part in a hundred, full scale. A final treatment of the most significant periods of activity was undertaken through the use of an Edwin Digitizer. The intensity resolution for those intervals was thereby increased by a factor of eight. After inspection to detect gross reading mistakes and to assure the compatibility of the digitization fre-

quency with the available information, the sections of the data were re-constituted by the computer to eliminate the discontinuities caused by gain changes or zero checks (the field procedure was to restrain the voltage output to ten volts full scale by changing the gain or limiting the light influx).

Calibration runs were carried out in the field before and after the observation period and were rechecked in the laboratory under a variety of circumstances. The two standards upon which greatest reliance was placed were a tungsten ribbon lamp and a quartz-iodine lamp. The results indicate reproducibility of about 3 percent for 5577A and 6300A, 15 percent for the ultraviolet channels and 10 percent for the red channels. The relative accuracy within each set of ultraviolet and red channels is about 7 percent.

Figure 4 presents the data taken on February 16 where the time origin is 0801:36.2 UT. All of the information there was obtained at a zenith angle of less than 3 degrees and no attempt has been made to correct for the effects of scattering or atmospheric extinction. However, the data presented in the figure represent the result of the subtraction of the background which was determined from

the intensities recorded two minutes before the passage of the auroral band.

The curves shown in the lower half of the figure are the intensity variations for various channels, namely 5577A, 6300A, the 0-2 band of the 2PG (CH3), and the 5-2 band of the 1PG (CH8). Two scales are used, one ranging from 0 to 10 KRS, the other from 0 to 100 KRS so that both the small and large scale fluctuations may be discerned. A symbol was produced for each tenth data point which fixes the spacing between symbols at five seconds. A straight line with no symbol is an interpolation of the data taken on each side and indicates the interval used to record gain settings on the strip chart. The upper half of the figure presents the intensity ratios of various emission features; 10/1, 9/2, 8/3 represent the possible 1PG/2PG ratios (numbers referring to the channels in table) and 6/4 the ratio of intensities for the green oxygen line and the near UV (0,0) N_2^+ band.

The figure presents a number of interesting features. The intensity of 5577A reaches a maximum value of 87 KRS placing this aurora in the IBC III range. Approximately one hundred seconds later, the intensity of 6300A reaches a maximum of 15 KRS, which corresponds to a 5577A/6300A

ratio of about 4, an extremely low value compared with the typical range of 30-50/1 generally observed in other periods of observation of bright aurora. Hence, the intensity of 6300A is one order of magnitude greater than the value measured under normal circumstances in bright auroras. The top half of the figure presents the interesting result that the 1PG/2PG ratios increase by a factor of two as the brightness of the aurora (measured by the intensity of 5577A) increases by a factor of ten. During this increase of the green line, the ratio of 5577A/3914A also increases by a factor of two. Both effects have been observed in a few of the brighter auroral displays in the remainder of the data but usually the enhancements do not occur to such a drastic degree.

A preliminary study of the intra-system brightness ratios of the 2PG, which are related to the apparent vibrational temperature of the ground state nitrogen molecules (Benesch, Vanderslice, and Tilford, 1966; Bates, 1949), indicates the occurrence of a significant redistribution of the population development corresponding to a temperature increase of 2000 degrees K. Since the investigation also shows that this temperature pulse appears in phase with the 6300A increase, there is reason to suspect

a strong relationship between the two events. Analysis of the remainder of the twenty hours of data in this study reveals no comparable effects. Since these two phenomena occurred during and only during the magnetic storm of the night of February 16, it seems quite possible that the emission structure of the aurora which took place that night became distorted, in the manner indicated, as a result of the simultaneous arrival of that magnetic storm.

DISCUSSION

It is a generally accepted tenet that aurorae occur with greater frequency and intensity during periods of enhanced solar activity. Accordingly, it would seem reasonable to assume that a fruitful line of endeavor would be an analysis of solar events and auroral displays to seek out cause and effect relationships between the two. Very little work has been done in this area, certainly there exist no extensive studies. The present investigation concerns an uncommonly bright solar flare and an aurora which was quite conclusively influenced by the unusual influx of solar material. There is no reason to conclude, however, that the flare was directly responsible for the aurora. In fact, this particular aurora (which occurred during the arrival of the bulk of the solar flare particle flux) was of only moderate brightness compared with the peak intensities recorded during the other four nights of auroral activity.

It has been stressed above that the 6300A component of the display attained 15 KRS, a value which was considerably above any other recorded for 6300A during the whole series of measurements. This OI ($^1D-^3P$) emission, of course, is known to occur at altitudes considerably

greater than those for the 1PG and the 2PG of molecular nitrogen. Nevertheless, during the present event, these three components of the emission structure peaked within one minute of one another and, in addition, served to delineate the detailed correspondence between the nitrogen molecular excitation rates and the 6300A emission that has been described in the preceding section. Hence, these observations suggest that the unusual influx of particles during this aurora had the effect both of enhancing the 6300A emission in the upper region and of increasing the apparent vibrational temperature of molecular nitrogen at the lower region of the atmosphere.

ACKNOWLEDGEMENTS

Our gratitude to Mr. W. Paulishak, the chief of the Geomagnetic Data Center of ESSA, Rockville, Maryland, for his cooperative aid in furnishing the magnetic data, and to Mr. E.I. Loomer of the Division of Geomagnetism of the Department of Energy, Mines, and Resources, Canada, for his assistance in the resolution of the Churchill magnetometer's traces is gratefully acknowledged. We are indebted to Miss V. Lincoln of the World Data Center A for her acquisition of the auroral visual observation data and for her helpful comments. We desire also to thank Miss D. Jelly of the Defense Research Telecommunication Establishment for the riometer data.

We wish to express our appreciation for the participation by Dr. J.T. Vanderslice in the field and for his subsequent interest and encouragement.

One of us (JWM) would like to thank NASA for the support of a Trainee Fellowship. The computer time for this project was supported by the National Aeronautics and Space Administration Grant NSG-398 to the Computer Science Center of the University of Maryland.

This research was supported in part by the National Science Foundation and by the U.S. Army Research Office-Durham.

REFERENCES

Bates, D.R., The intensity distribution in the nitrogen band systems emitted from the earth's upper atmosphere, Proc. R. Soc A196, 217 (1949).

Benesch, W., J.T. Vanderslice, and S.G. Tilford, Excitation rates in the auroral nitrogen second positive group, J. Atmosph. Terr. Phys. 28, 431 (1966).

ESSA, Solar-Geophysical Data, IER-FB series, published by Environmental Science Services Administration, Environmental Data Service, Boulder, Colorado.

Harang, L., The Forbush-decrease in cosmic-rays and the transit time of the modulating cloud, Planet. Space Sci. 16, 1095 (1968).

Hultqvist, B., Ionospheric absorption of cosmic radio noise, Space Science Reviews 5, 771 (1966).

Ogilvie, K.W., L.F. Burlaga, and T.D. Wilkerson, Plasma Observations on Explorer 34, J. Geophys. Res. 73, 6809 (1968).

FIGURE CAPTIONS

- Figure 1. Evidence indicating the presence of a magnetic storm February 16 following the solar flare of February 13. (ESSA, Solar-Geophysical Data).
- Figure 2. Comparison of two magnetometer traces, Churchill and Fredericksburg, with the Churchill riometer measurements.
- Figure 3. The probe unit of the filter-wheel photometer. Not shown in this simplified diagram is a long lens hood, a graduated series of alternating caps, and the signal conditioning electronic components. The field of view of the telescope is about one and a half degrees.
- Figure 4. The auroral emission features and selected ratios as a function of time. The two lower graphs, presenting the intensities of individual channels, are identical except for scaling. There are 10 data points for the five second time interval which is marked at both ends by symbols.

TABLE CAPTION

The channel format for the filter-wheel photometer. Although the channels were generally sequenced in order of increasing wavelength, 5715A was inserted in channel 5 so that the oxygen lines could be adjacent. The bandwidths are full widths at half height.

<u>Channel</u>	<u>Band Width(A)</u>	<u>Wavelength(A)</u>	<u>Identification</u>
1	27	3710	N ₂ Second Positive System ΔV = -2 Sequence
2	23	3750	
3	29	3807	
4	48	3914	N ₂ ⁺
5	40	5715	Background
6	30	5577	OI Green line
7	11	6300	
8	52	6680	N ₂ First Positive System ΔV = 3 Sequence
9	55	6770	
10	55	6850	

RADIO PROPAGATION QUALITY FIGURES AND FORECASTS

FEBRUARY 1967

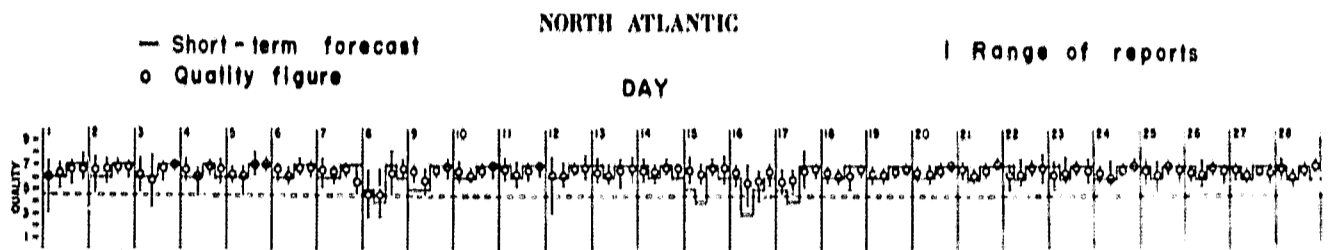

COSMIC RAY INDICES

(Pressure Corrected Hourly Totals)

FEBRUARY 1967

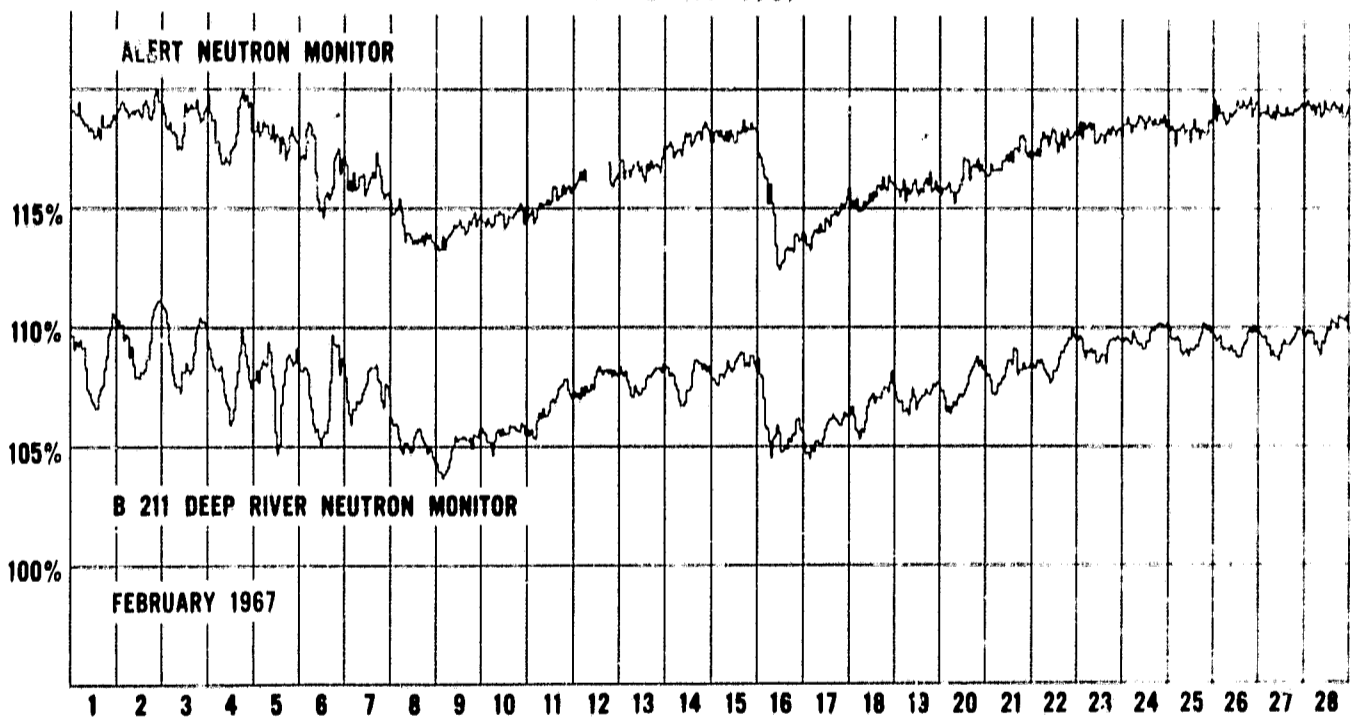

GEOMAGNETIC ACTIVITY INDICES



KEY

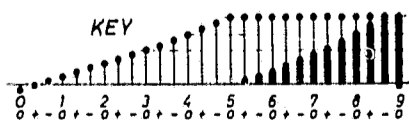

▲ = sudden commencement

PLANETARY MAGNETIC
THREE-HOUR-RANGE INDICES

CHURCHILL X-COMPONENT
MAGNETOMETER TRACE

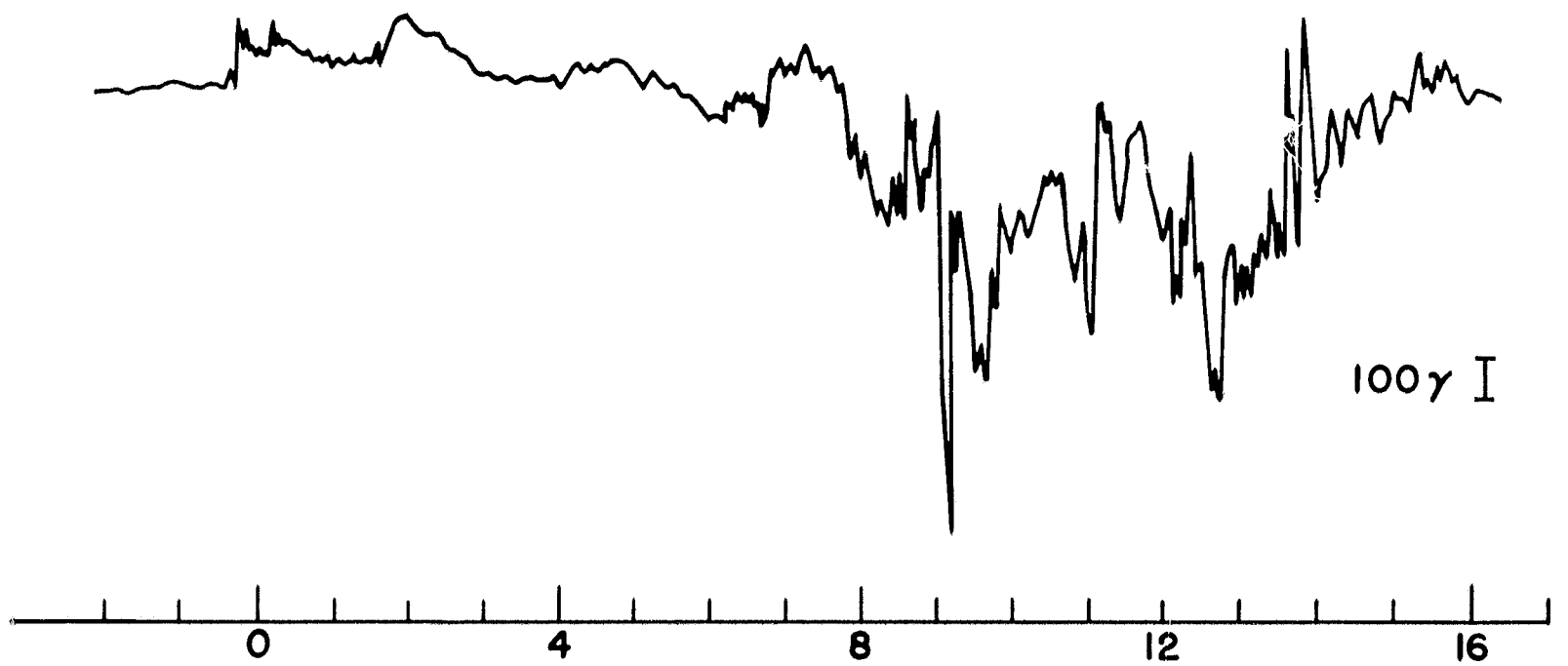

FREDRICKSBURG (VIRGINIA) HORIZONTAL
MAGNETOMETER TRACE

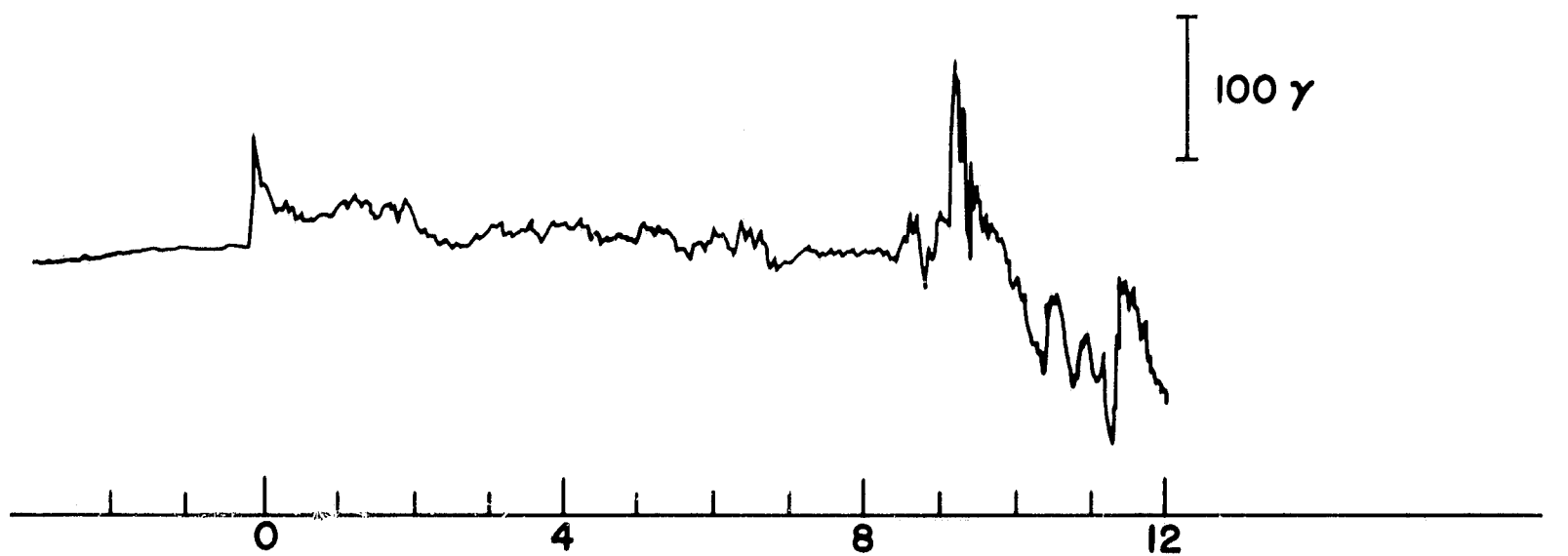

CHURCHILL RIOMETER

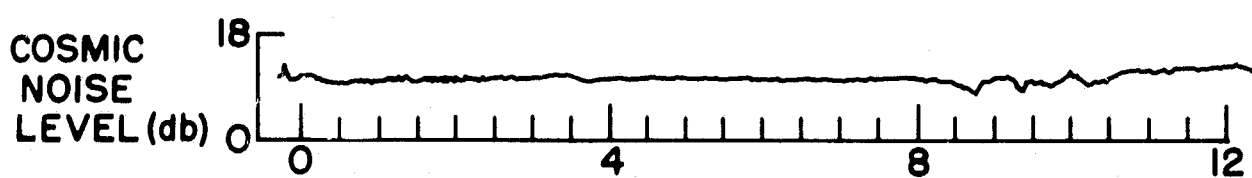

UT (FEBRUARY 16, 1967)

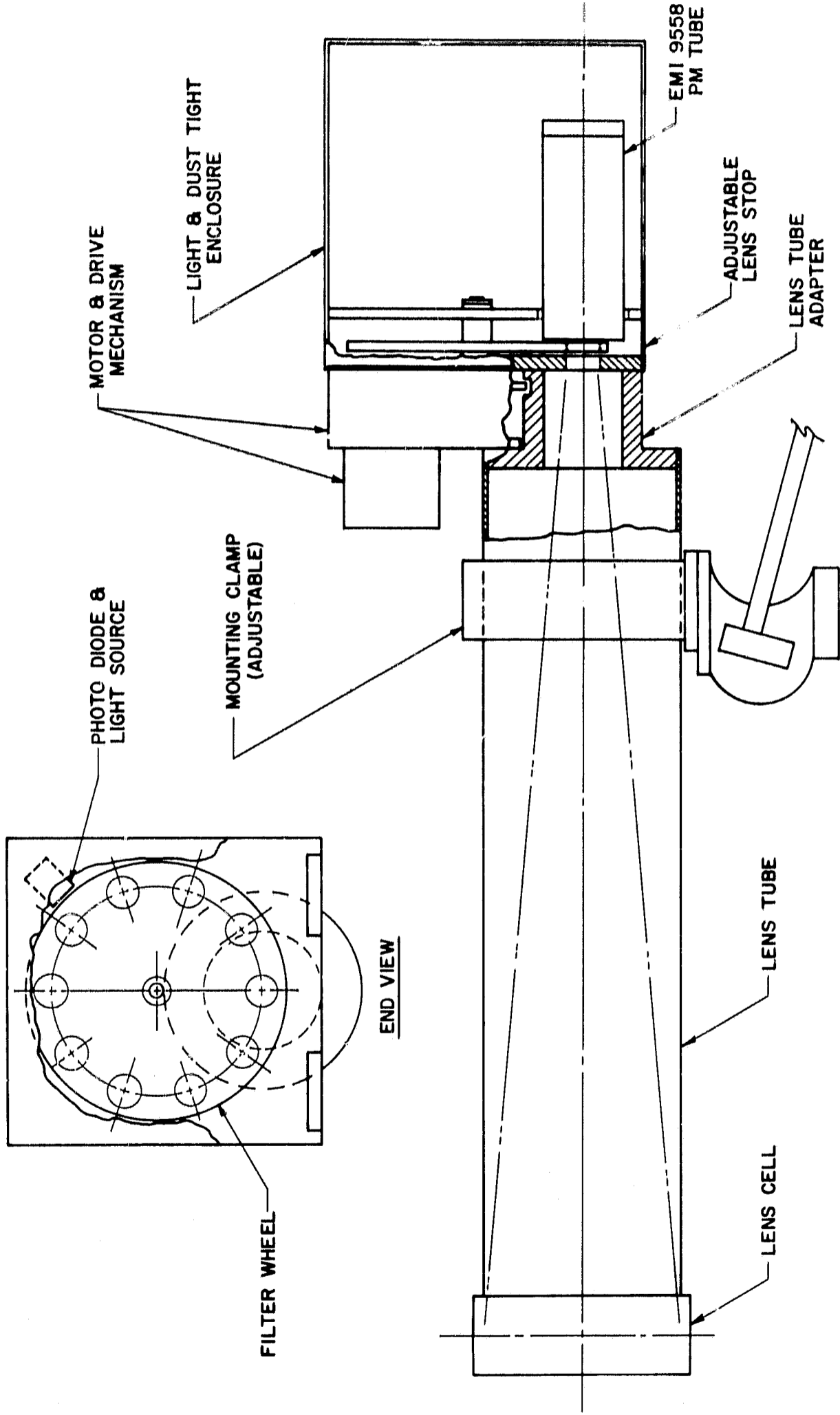

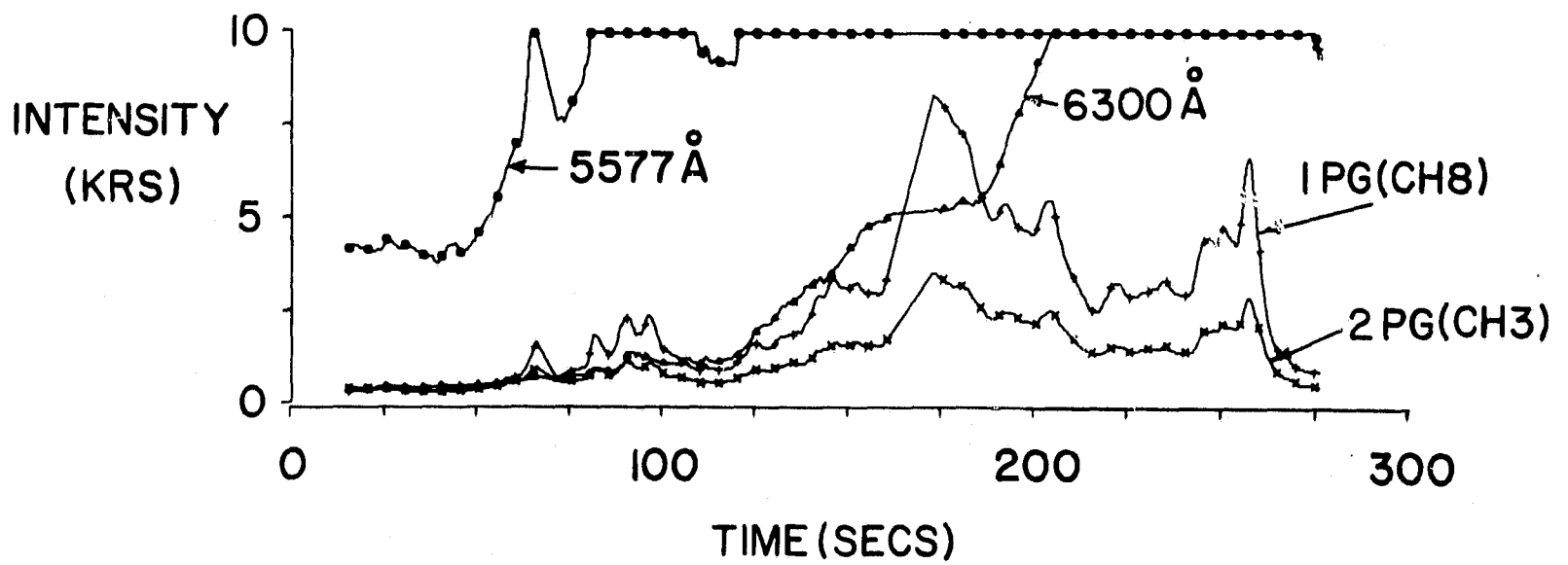
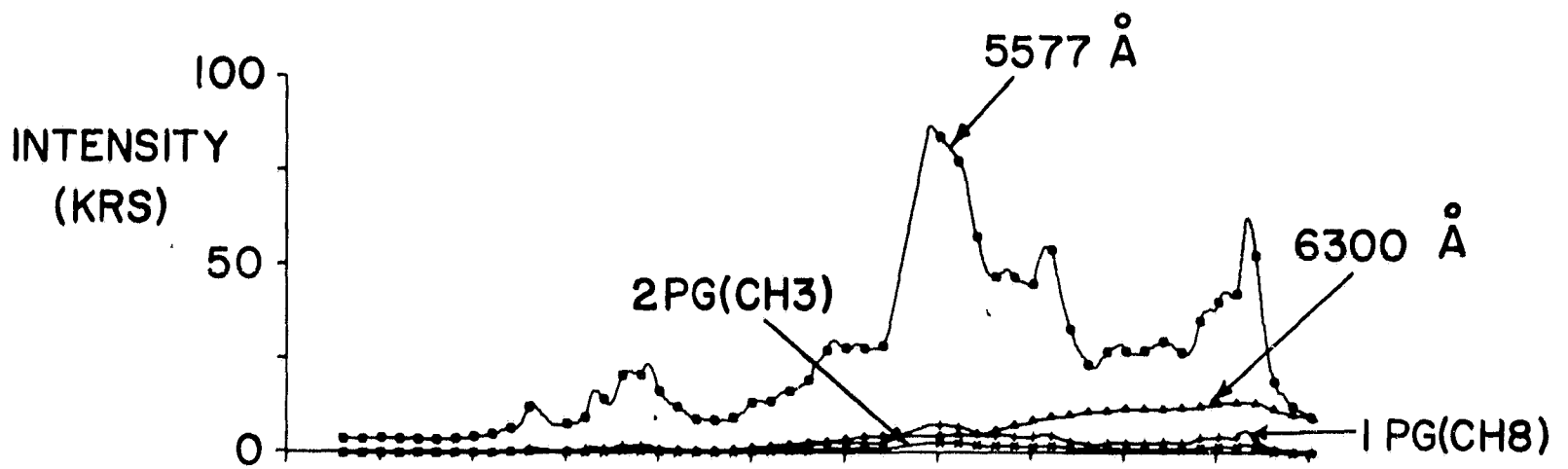
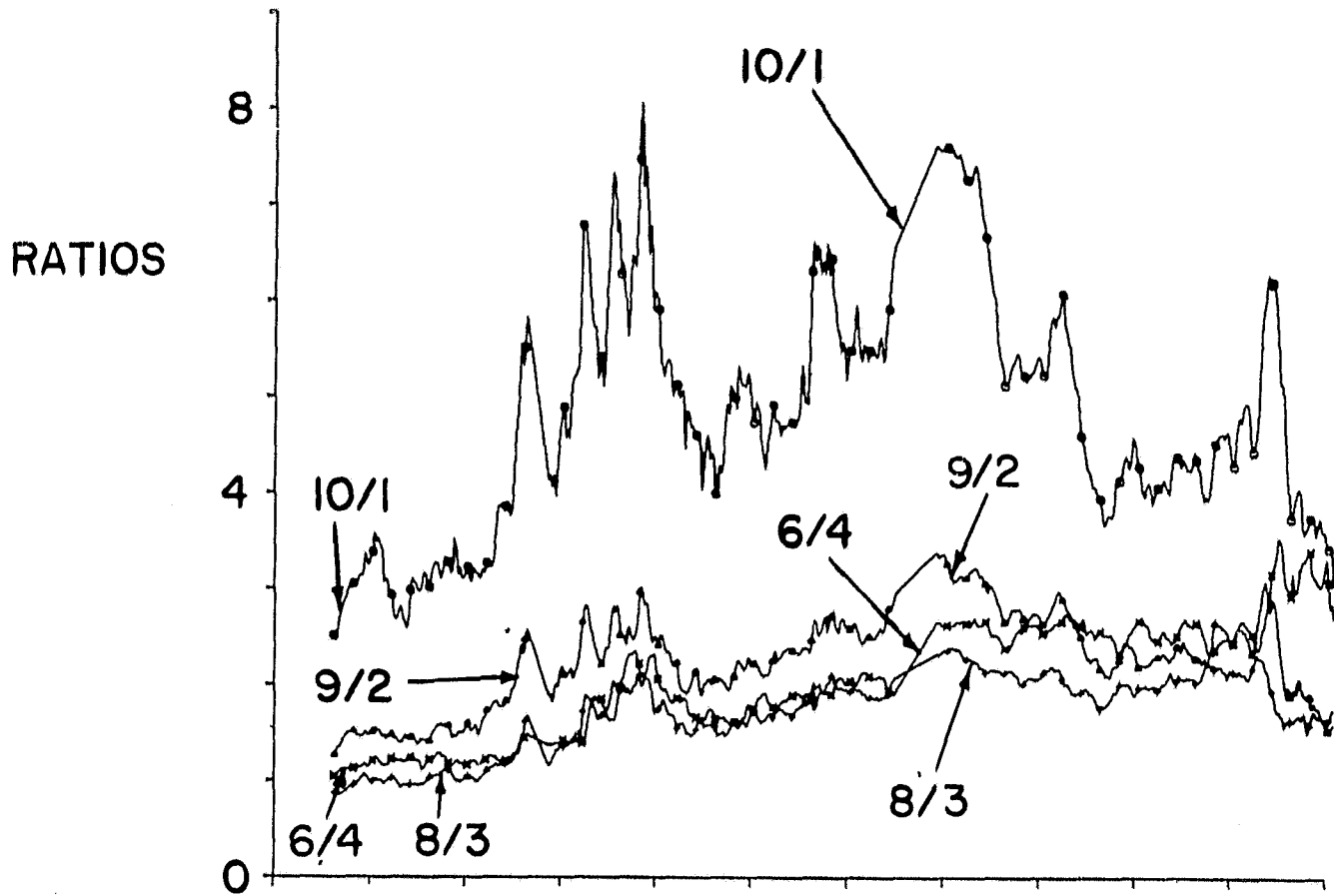

ACKNOWLEDGEMENTS

Our gratitude to Mr. W. Paulishak, the chief of the Geomagnetic Data Center of ESSA, Rockville, Maryland, for his cooperative aid in furnishing the magnetic data, and to Mr. E.I. Loomer of the Division of Geomagnetism of the Department of Energy, Mines, and Resources, Canada, for his assistance in the resolution of the Churchill magnetometer's traces is gratefully acknowledged. We are indebted to Miss V. Lincoln of the World Data Center A for her acquisition of the auroral visual observation data and for her helpful comments. We desire also to thank Miss D. Jelly of the Defense Research Telecommunication Establishment for the riometer data.

We wish to express our appreciation for the participation by Dr. J.T. Vanderslice in the field and for his subsequent interest and encouragement.

One of us (JWM) would like to thank NASA for the support of a Trainee Fellowship. The computer time for this project was supported by the National Aeronautics and Space Administration Grant ^{NSG-21-002-005} (NSG-398) to the Computer Science Center of the University of Maryland.

This research was supported in part by the National Science Foundation and by the U.S. Army Research Office-Durham.