

CASE FILE COPY

11 69-15 716

NASA CR - 99141

Antenna Laboratory Report No. 68-4

EXPERIMENTAL STUDY OF THE IMPEDANCE OF A SHORT DIPOLE IN A PLASMA
FOR PARALLEL AND PERPENDICULAR ORIENTATION WITH RESPECT
TO THE D.C. MAGNETIC FIELD

by

Dan E. Snyder and R. Mittra

Scientific Report No. 11

December 1968

Sponsored by

National Aeronautics and Space Administration

NASA(NsG 395) *NGR-14-005-009*

Antenna Laboratory
Department of Electrical Engineering
Engineering Experiment Station
University of Illinois
Urbana, Illinois 61801

Antenna Laboratory Report No. 68-4

EXPERIMENTAL STUDY OF THE IMPEDANCE OF A SHORT DIPOLE IN A PLASMA
FOR PARALLEL AND PERPENDICULAR ORIENTATION WITH RESPECT
TO THE D.C. MAGNETIC FIELD

by

Dan E. Snyder and R. Mittra

Scientific Report No. 11

December 1968

Sponsored by

National Aeronautics and Space Administration

NASA NsG 395

Antenna Laboratory
Department of Electrical Engineering
Engineering Experiment Station
University of Illinois
Urbana, Illinois 61801

ABSTRACT

Measurements were made of the input admittance of a small dipole immersed in a steady-state plasma with an external magnetic field. Antenna orientations parallel and perpendicular to the magnetic field were studied. The data were compared to theoretical expressions derived previously by Balmain and fairly good qualitative agreement was found.

ACKNOWLEDGMENT

The authors wish to acknowledge the support of the National Aeronautics and Space Administration through Grant No. NsG-395. Also, appreciation is expressed to Professor Deschamps and the other members of the Antenna Laboratory for many useful ideas and fruitful discussions.

TABLE OF CONTENTS

	Page
1. INTRODUCTION	1
2. THEORETICAL ANALYSIS	3
3. THE EXPERIMENTAL APPARATUS	6
4. THE ANTENNA SYSTEM	15
5. THE EXPERIMENTAL MEASUREMENTS	24
6. CONCLUSIONS	32
LIST OF REFERENCES	34

LIST OF FIGURES

Figure	Page
1. The plasma discharge tube. The antenna enters through the O-ring joint	7
2. Detail of the cathode end of the tube.	9
3. Detail of the anode end of the tube.	9
4. Placement of the field coils	11
5. Detail of the quick disconnect probe seal.	12
6. Block diagram of the measurement system. The D.C. block allows a bias potential between anode and antenna.	16
7. The dipole antenna and feedline.	18
8. Insertion of the antenna into the chamber.	20
9. Shorting block. The spaces between the coax and block are filled with mercury.	21
10. Plot of measured and calculated free space admittances . . .	23
11. Measured admittances for the two cases. $B = 256$ Gauss . . .	27
12. Calculated admittances. Corrected $B = 229$ Gauss. $T_e = 1000^{\circ}\text{K}$. $N_e = 2.1 \times 10^{10}/\text{cm}^3$	28
13. Measured admittances for the two cases. $B = 171$ Gauss . . .	29
14. Calculated admittances. Corrected $B = 177$ Gauss. $T_e = 1000^{\circ}\text{K}$. $N_e = 1.82 \times 10^{10}/\text{cm}^3$	30

1. INTRODUCTION

This report describes a recent series of experiments involving the measurement of antenna impedance in an anisotropic plasma. In the present case, the measurements were performed on an electrically short dipole. The experiment was similar to one reported by Balmain (1963) in which he measured the impedance of a small monopole in a pulse discharge plasma. The anode served as the ground plane and the magnetic field was parallel to the antenna. Balmain compared the measured impedances to those predicted by a theory which he developed in the same paper. The study to be presented differs from Balmain's work in two important respects:

1. The plasma was steady state rather than pulsed.
2. A full dipole antenna was used rather than a monopole.

The first of these refinements was made to remove any ambiguities associated with a pulsed plasma. With the pulse discharge, all measurements must be made in a period of a few microseconds during which the plasma parameters are assumed constant. However, none of the quantities being measured are at their steady state values and the possibility exists that the data include some transitory effects that the steady state theory cannot predict. Steady state measurements are also easier to make and are generally more precise than pulse technique measurements.

The second refinement is the essential difference between the two experiments. The dipole, unlike the monopole, can be placed with arbitrary orientation to the external magnetic field. Thus, data could be obtained

for orientations other than parallel--in this case, the perpendicular orientation. Heretofore, to this author's knowledge, there has been no such published data. Additionally, the use of a dipole allows placement of the antenna in the most uniform region of the plasma (away from boundaries) rather than in a most nonuniform region (adjacent to the anode).

Stated succinctly, the purpose of the experiment was to repeat Balmain's experiment with what was thought to be improved apparatus and then to extend the investigation by measuring impedances with the dipole oriented perpendicular to the external magnetic field.

2. THEORETICAL ANALYSIS

Balmain (1963) derived impedance expressions for an electrically short dipole immersed in an infinite cold plasma medium. The presence of an external magnetic field causes the medium to be anisotropic. There are assumed to be no sheath effects present, i.e., the medium is homogeneous. The impedance formulas obtained are the quasistatic expressions-- those obtained by writing down general field expressions and letting ω approach zero while the plasma parameters and antenna dimensions remain fixed. This is equivalent to shrinking the dipole to elemental proportions. The derivation also requires that the ratio of antenna diameter to length be much less than one. For the two cases of interest, the general expression reduces to:

Parallel case

$$Z_{in} = \frac{2}{j\omega 2\pi \epsilon_o K'L} \left[\ln \frac{L}{\rho} - 1 + \ln a \right] \quad (2.1)$$

Perpendicular case

$$Z_{in} = \frac{2a}{j\omega 2\pi \epsilon_o K'L} \left[\ln \frac{L}{\rho} - 1 - \ln \frac{a+1}{2} \right] \quad (2.2)$$

where L = dipole half length, ρ = dipole radius.

$$K' = 1 - \frac{XU}{U^2 - Y^2} \quad U = 1 - jZ$$

$$K_o = 1 - \frac{X}{U} \quad a^2 = \frac{K'}{K_o}$$

and X, Y, and Z are the usual plasma parameters defined by:

$$X = \frac{\omega_N^2}{\omega^2}, \quad \omega_N^2 = \frac{N_e e^2}{m \epsilon_0}$$

$$Y = \frac{\omega_H}{\omega}, \quad \omega_H = \frac{e B_0}{m}$$

$$U = 1 - jZ, \quad Z = \frac{\nu}{\omega}$$

with

ω = R.F. radian frequency.

ϵ_0 = permittivity of free space.

N_e = electron density.

e = magnitude of electron charge.

m = electron mass.

ν = collision frequency of electrons.

B_0 = D.C. magnetic flux density.

Rationalized M.K.S. units were used throughout the formulation.

There are two possible ambiguities present in these formulas. Namely, the square root of a complex quantity and the logarithm of a complex quantity must be taken. If the branch cuts for the square root and the log functions are taken along the negative real axis, the calculated impedances, Z_{in} , satisfy the following physical conditions:

1. Z_{in} has no negative real parts.
2. Z_{in} varies continuously with the plasma parameters.
3. Z_{in} approaches the free space results for small X, Y, and Z.

Explicitly, the branches of the two multivalued functions are defined by:

$$\ln(re^{j\theta}) = \ln r + j\theta$$

$$(re^{j\theta})^{\frac{1}{2}} = r^{\frac{1}{2}} e^{j\frac{1}{2}\theta}$$

where, in both cases, $-\pi < \theta \leq \pi$. All of the theoretical results presented in the data section were obtained by straightforward evaluation on a 7094 computer.

3. THE EXPERIMENTAL APPARATUS

A brush cathode glow discharge tube was used to generate and contain the plasma medium (Persson 1964). The essential features of the tube are shown in Figure 1. The brush cathode consisted of approximately 1600 tungsten wires, .025" in diameter and 1.5" long, brazed end on to a molybdenum baseplate. The wires were pointed by electrolytic etching in a solution of KOH and water. A compressed carbon jig held the pins in place on the baseplate while the assembly was brazed in a hydrogen furnace. Center to center pin spacing was .060".

The brush cathode in this experiment was identical to that used by Duff (1966), although the chamber design was quite different. The final brush cathode design was arrived at after several attempts with simpler designs. (The final cathode is difficult and tedious to construct and is difficult to mount in the chamber.) One of the other designs tried was a brush using only 50 tungsten rods 1/8" in diameter. Such a radical departure from the design of Duff was prompted by the success of a similar cathode built by Kostelnicek (1965). The baseplate was stainless steel and was made so that it could be sealed to the glass with epoxy. The new cathode was considerably more rugged, easier to build, and easier to fasten to the glass than the old brush. Unfortunately, the plasma was not satisfactory, especially in the presence of a magnetic field. Construction of this tube also brought to light the fact that although an epoxy joint between the baseplate and the glass was strong and easy to make, it was not reliable. This is because the coefficients

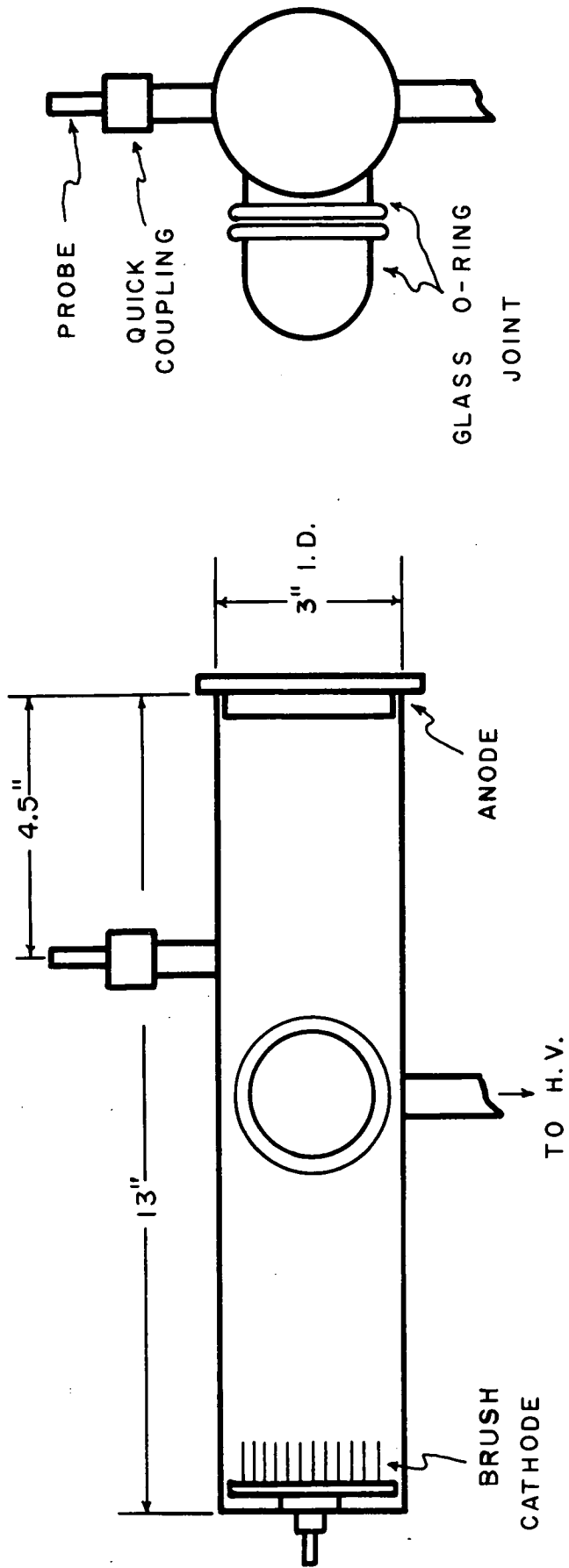

FIGURE 1. THE PLASMA DISCHARGE TUBE. THE ANTENNA ENTERS THROUGH THE O-RING JOINT.

of expansion of stainless steel and glass differ markedly. Any thermal shock is, therefore, quite likely to cause the appearance of cracks in the glass near the epoxy joint.

One of the problems with the final cathode was solved with a novel method of mounting it in the tube. A 1/4" stainless steel rod was brazed end on to the back of the baseplate. The rod was passed through a hole in a 5/16" thick glass plate epoxied to the end of the glass chamber (see Figure 2). The cathode was then pulled tight against the glass plate by a nut threaded on the steel rod. The required vacuum seal was made with a 1/4" I.D. O-ring and compression washer obtained from a 1/4" Quick Coupling manufactured by Veeco. This arrangement allows quick and easy removal of the cathode as opposed to the rather permanent nature of either glass to metal or epoxy seals. The epoxy joint between the glass cylinder and the glass plate is reliable since the coefficients of expansion are matched.

Since it was desirable to be able to remove the cathode from the tube, the anode also had to be removable. This was accomplished rather simply by placing a 1/8" thick neoprene rubber gasket between the anode and the polished end of the glass cylinder (see Figure 3). The required pressure on the gasket was maintained by the force of the atmosphere on the evacuated chamber walls. A teflon tubing shield was placed in front of the gasket to prevent any plasma from reaching and possibly damaging the neoprene.

The anode material was 304 stainless steel. A square array of holes was drilled in the face of the anode to increase its surface area. This geometry is the so-called "inverse brush" described by Musal (1966). Although Musal used the inverse brush as a cathode, it

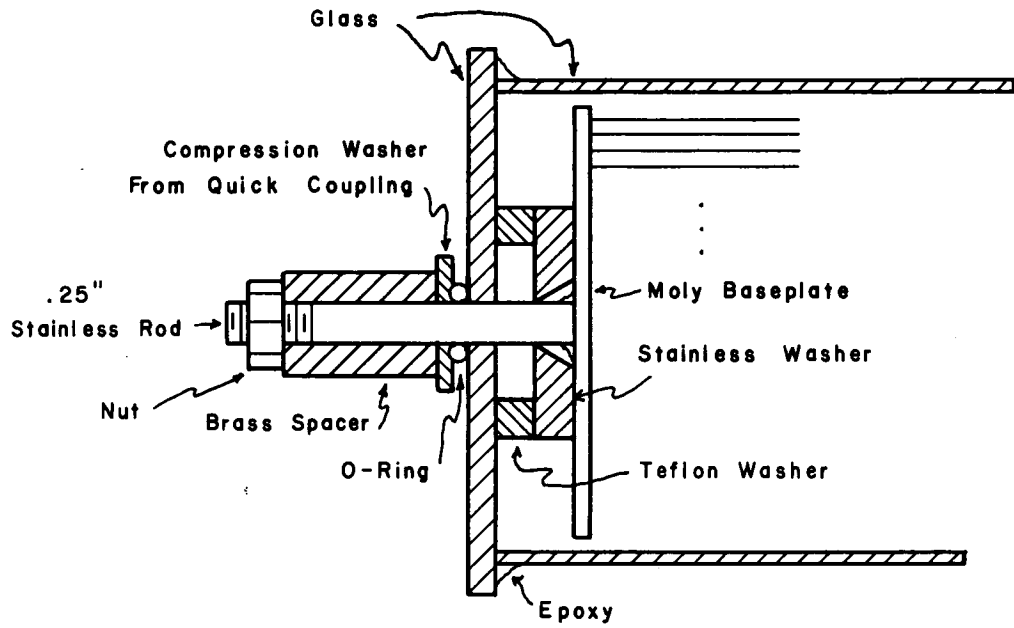

FIGURE 2. DETAIL OF THE CATHODE END OF THE TUBE.

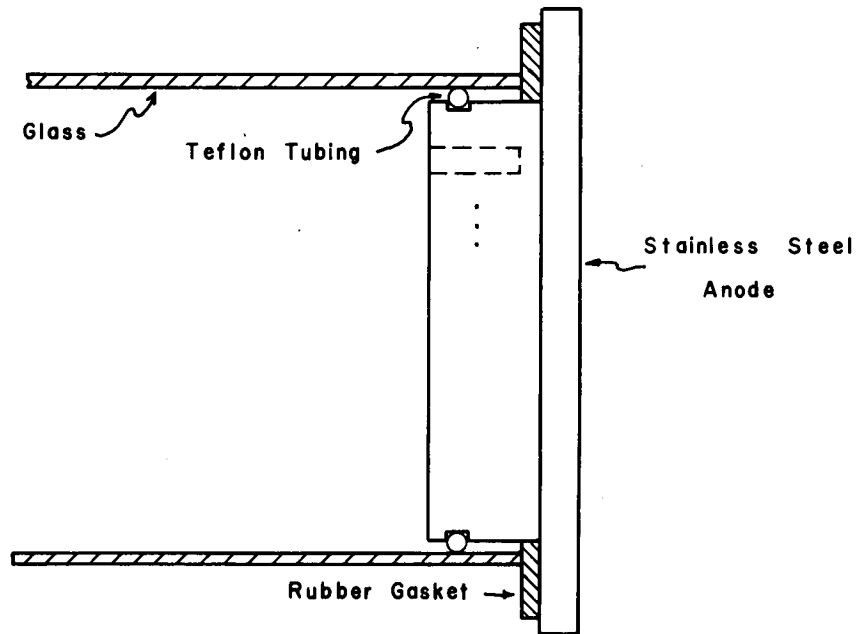

FIGURE 3. DETAIL OF THE ANODE END OF THE TUBE.

makes an excellent anode with less tendency to give anode spots than a flat plate.

The external magnetic field was supplied by several coils placed around the chamber as shown in Figure 4. The magnetic field in the empty chamber was found to be reasonably uniform in the region where the antenna was located. The maximum field strength possible without excessive heating of the coils was 256 Gauss. Field strengths were determined with a Beckman 350 Hall device.

Since the plasma parameters were to be measured with probes, an arrangement allowing easy insertion and removal of a probe was devised. A Veeco 1/4" Quick Coupling was machined so that it could be soft soldered to a 1/2" kovar to glass seal (see Figure 5). The glass part of the assembly was then permanently sealed into the tube. Probes mounted on a 1/4" diameter glass tubing could then be put in and removed while the chamber was at atmospheric pressure.

A vacuum system consisting of a Veeco VE 2AB 2" air cooled diffusion pump backed by a Welsh Duoseal fore pump was employed to pump the chamber to a high vacuum prior to back filling with helium. A water cooled baffle and a cold trap reduced the backstreaming of oil into the tube. All valving in the high vacuum line was metal. A Veeco ionization gauge and a CVC Pirani gauge monitored the pressure in the high vacuum line. A helium reservoir connected to the high vacuum line through two micrometer valves allowed fine control over the amount of gas introduced into the tube. The vacuum system achieved pressures in the 10^{-7} Torr range without the tube and maintained a pressure of $1. \times 10^{-5}$ Torr with the tube. This pressure difference was due to the large volume of the chamber and the continuous outgassing of the various materials inside it.

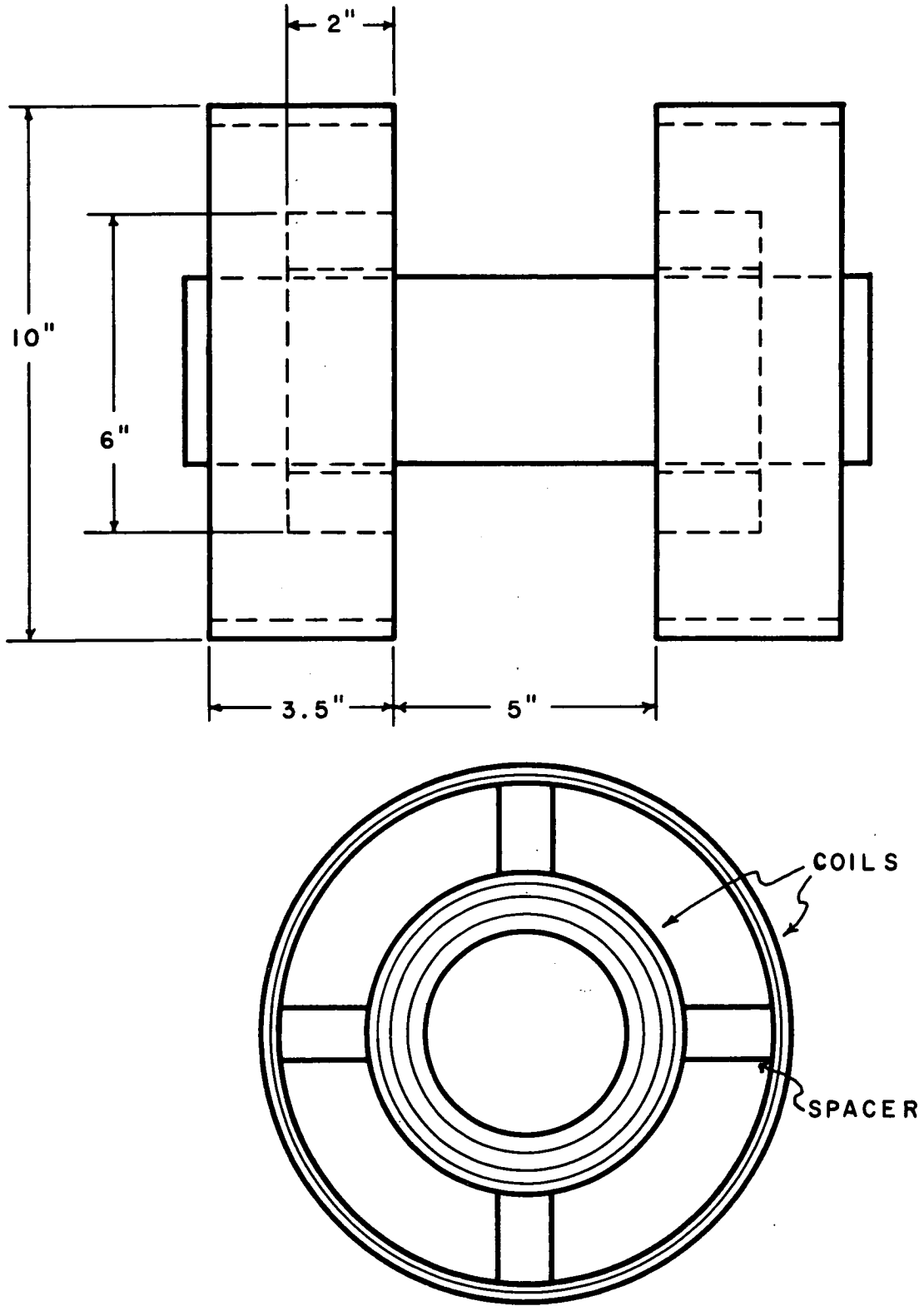

FIGURE 4. PLACEMENT OF THE FIELD COILS.

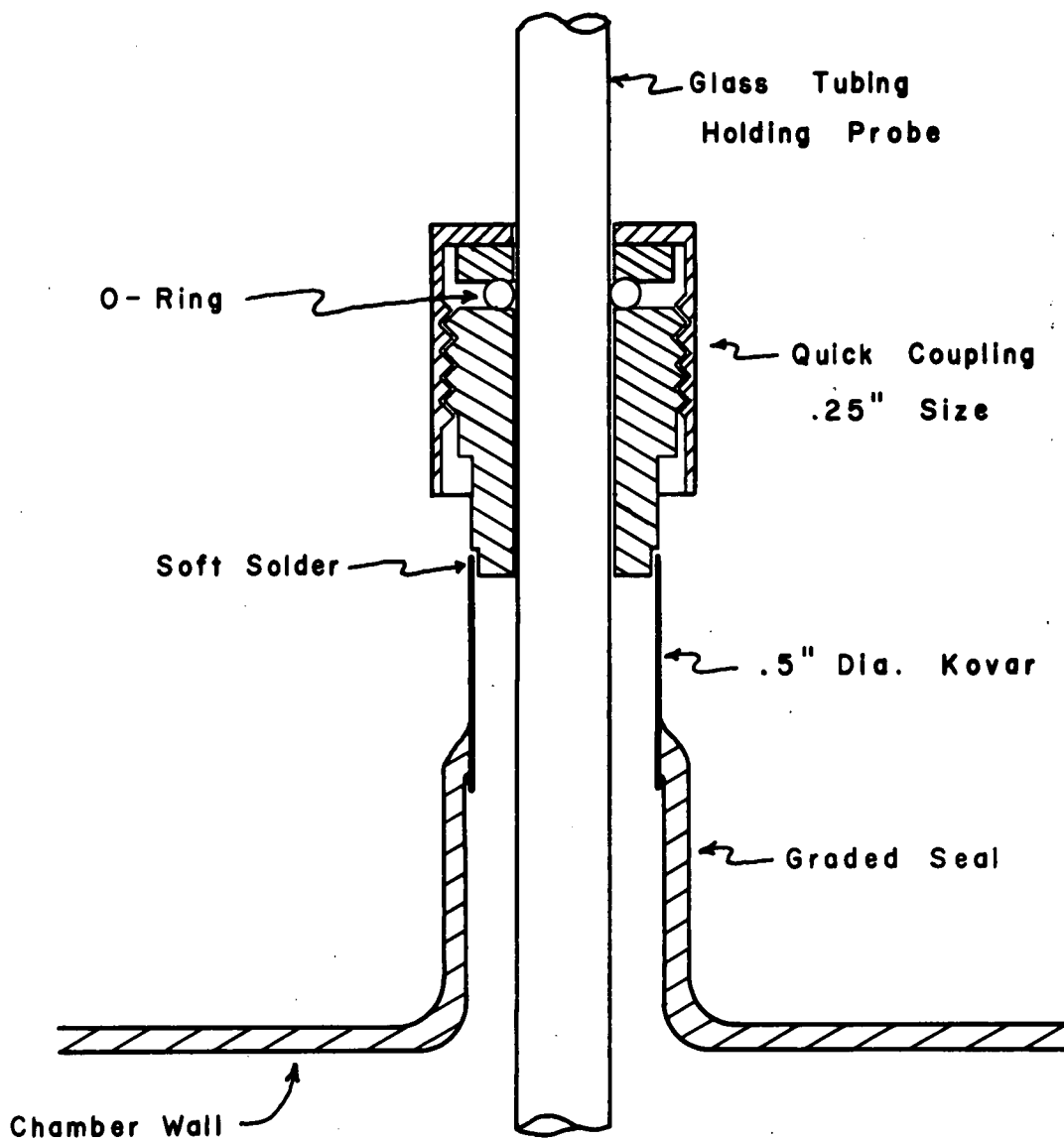

FIGURE 5. DETAIL OF THE QUICK DISCONNECT PROBE SEAL.

Preparation of the chamber for an experiment was straightforward. Starting at atmospheric pressure, the tube was forepumped down to a pressure of 20 microns. The diffusion pump (already operating properly) was then allowed to pump on the system. The cold trap was kept full of liquid nitrogen during the time the tube was evacuated. A pumping time of 8 to 12 hours was required to bring the pressure down to 10^{-5} Torr. A vacuum was maintained in the chamber even when experiments were not being performed in order to keep the tube and electrodes clean.

Immediately prior to an experiment, the tube was backfilled with helium to a pressure of .3 Torr and the discharge was initiated. Invariably, after a period of non-use, there would be a substantial pressure rise (up to .2 Torr) during the first 30 minutes of operation. This pressure rise was attributed to be due to oil and grease which had imigrated from the diffusion pump and the greased gasket and O-rings used on the tube. The tube was pumped down again for 15 minutes and the process repeated once or twice more until pressure rises were small and confined to the first few minutes after turn-on of the discharge.

A brief discussion of the nature of the discharge is appropriate. The lowest pressure for which the discharge was useful was .2 Torr. (All helium pressures were measured with a CVC Pirani gauge using the manufacturer's correction curve.) The tube "fired" at about 3000 volts and maintained a 10 mA discharge current in the same voltage range. The discharge was greenish blue and it completely filled the space between the anode and the cathode. The region between the wires on the brush was filled with a pink glow and the anode was completely dark. The plasma was visually very uniform in both transverse and longitudinal

directions. The maximum usable pressure was .5 Torr. above which, plasma striations, namely, spots on the anode, started to appear. Breakover voltage was reduced to 1000 volts or below and a 10 m A. discharge current was maintained in the 1500 volt range. The plasma was more bluish than at .2 Torr and most of the pink glow between the brush wires was supplanted by a bluish glow. There was noticeable attenuation of the plasma near the anode. The magnetic field had the effect of contracting the plasma slightly away from the walls and brightening the intensity of the glow. Also, the plasma became more uniform for the higher pressure discharges. In all cases, the discharge current was little affected by application of the magnetic field.

4. THE ANTENNA SYSTEM

Considerable effort was spent on the development of the antenna, its feed system and impedance measurement instruments since the accurate measurement of antenna impedance was the central concern of the experiment. It was discovered very soon in the study that impedance measurements of short dipoles ($.08 \lambda$ to $.17 \lambda$) over a wide frequency range (.5 to 1.0 GHz) were at best difficult. To compound the difficulties, the antenna had to be placed inside a high vacuum chamber and subjected to a rather hostile environment.

Slotted line techniques were used to make the antenna measurements for reasons of accuracy and wide bandwidth. The problem of coupling the dipole which must be fed in the balanced configuration to the slotted line which is an unbalanced system was resolved by using the "double slotted line" technique (see Dyson, 1964). The method makes use of two matched slotted lines fed 180° out of phase by means of a hybrid. The output ends of the slotted lines connect to two coaxial lines of identical length, each of which feeds one element of the dipole. Since the two paths from the hybrid to the antenna are matched in length, the 180° phase relationship is maintained at the dipole terminals. Furthermore, the impedance measurements are made on the dipole side of the hybrid so there are no discontinuities between the measurement device and the antenna except connector and feed point discontinuities. The signal generating and measuring apparatus on the input side of the hybrid were conventional. A block diagram of the entire system is shown in Figure 6.

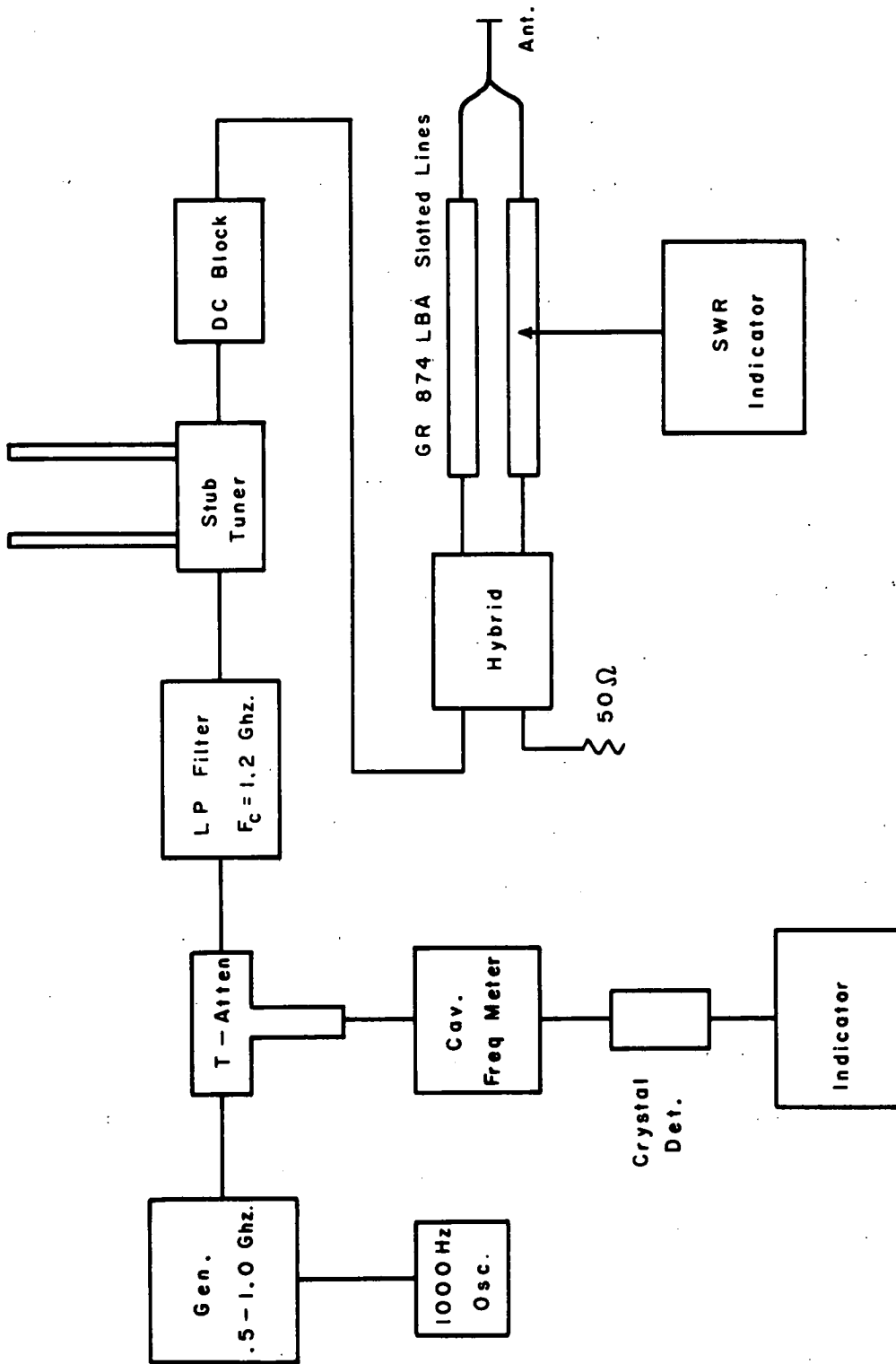

FIGURE 6. BLOCK DIAGRAM OF THE MEASUREMENT SYSTEM. THE DC BLOCK ALLOWS A BIAS POTENTIAL BETWEEN ANODE AND ANTENNA.

Subminiature, solid outer conductor coax was used for the feedlines to keep feedpoint dimensions small while maintaining low losses. The cable had an O.D. of .086" and was manufactured by Uniform Tubes, Inc. (type #UT 85). This cable mates with type OSSM connectors which have very good characteristics in the frequency range of interest. The use of the particular coax also solved the problem of introducing the transmission line into the high vacuum chamber. It was found that the cable was vacuum tight. That is, one end was exposed to atmospheric pressure without measurable leakage through the cable. (There is some leakage for very short lengths, but it is negligible for lengths greater than about five inches.)

The dipole was constructed in the following manner. The two coaxial lines were placed side by side at the feed point and soldered together. The lines ran together for nine inches and then were bent so as to connect to the slotted lines. At the dipole end, the inner conductors were brought out a distance of about 3 mm. The dipole consisted of two lengths of molybdenum wire spot welded to the protruding inner conductors as shown in Figure 7. Molybdenum was chosen because it is both resistant to the plasma and can be readily spot welded to copper. The molybdenum wire must be nickel flashed (electroplated) before it is spot welded to insure a good bond. The antenna dimensions were 5.0 cm total length and .0504 cm in diameter.

Although the antenna was plasma resistant, the copper feedline was not. The twin coax was, therefore, isolated from the plasma by surrounding it with a glass tube. The glass could not be brought right up to the feedpoint, however, because of noticeable effects on antenna

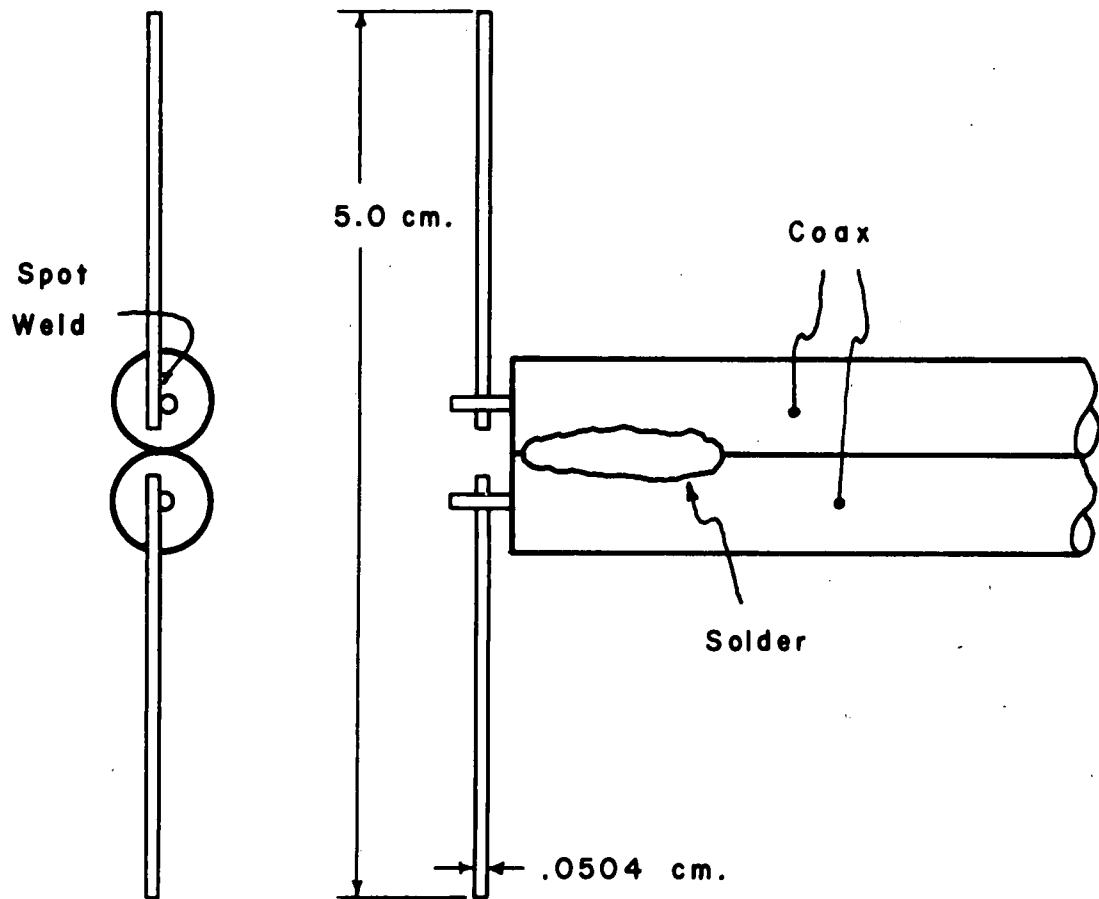

FIGURE 7. THE DIPOLE ANTENNA AND FEEDLINE.

impedance. Thus, the glass sheath only covered to within one inch of the feedpoint. The remaining exposed coax was protected by wrapping it with a thin layer of teflon tape. This tape has no adhesive backing but forms very well to most any surface. It is vacuum stable and was found not to be affected by the plasma. The entire antenna and feed-line assembly is shown in Figure 8.

It was felt that a necessary check on the reliability of the measurements that were to be taken was that free space antenna measurements should agree with the well-known results. This would give some confidence that the measurements in the plasma actually reflected the effects of the plasma rather than antenna or feedline peculiarities. The free space measurements were carried out as follows. The slotted line method calls for a null position with a short placed at the antenna plane. These "shorted" null positions were made before the antenna was spot welded in place and before the two cables were soldered together. A brass shorting piece was placed on each of the cables to provide the short (see Figure 9). Note that the short is placed right at the end of the outer conductor and is not exactly at the plane of the antenna. The "shorted" nulls were obtained for frequencies of 500 to 1000 MHz at 50 MHz intervals. The two cables were then soldered and another series of null positions recorded for the open-circuited cables. Finally, the antenna arms were welded in place and the antenna nulls recorded. The shorted nulls and antenna nulls were used to calculate the "uncorrected" antenna impedance. As was found from measurements on several antennas, this "uncorrected" impedance does not behave as is theoretically predicted (monotonically increasing reactance as frequency decreases), but rather shows erratic variation. This variation was considered to be due

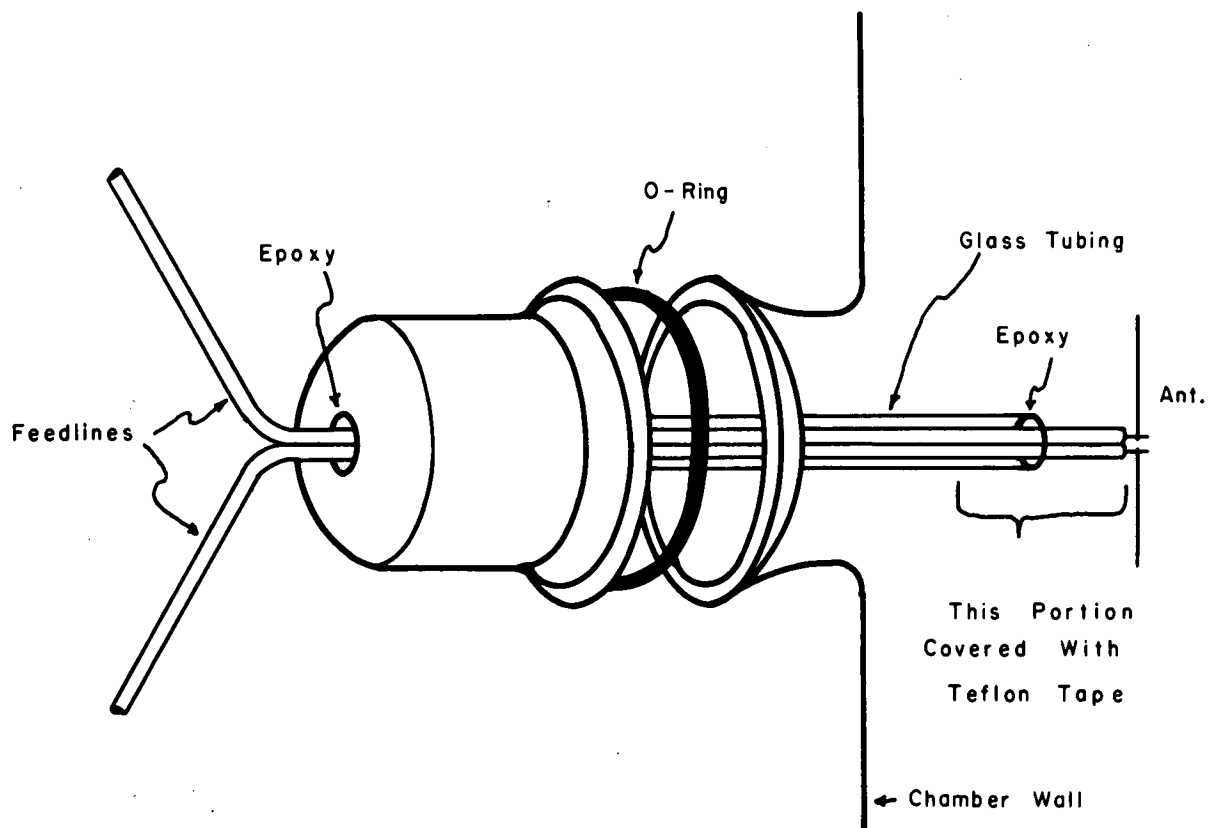

FIGURE 8. INSERTION OF THE ANTENNA INTO THE CHAMBER.

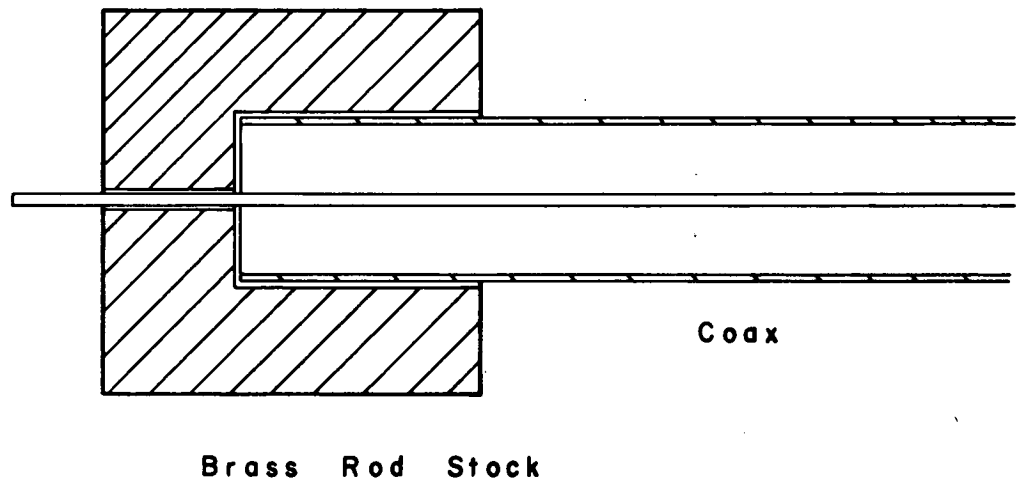

FIGURE 9. SHORTING BLOCK. THE SPACES BETWEEN THE COAX AND BLOCK ARE FILLED WITH MERCURY.

to stray reactances at the feed point caused by the discontinuity of cutting off the coaxial line and by the short extension of inner conductor. An indication of this was that when impedances were calculated for the "open circuit" nulls an erratically varying reactance was found. Therefore, the "uncorrected" impedances were considered to be the parallel combination of the actual dipole impedance and the stray impedance. When the effects of the stray impedance are compensated for, the result is the "corrected" antenna impedance. A plot of "corrected" admittance versus frequency is shown in Figure 10. As can be seen, the agreement between measurements and theory is within about 7%. It was concluded, therefore, that reliable plasma measurements could be made with this antenna system.

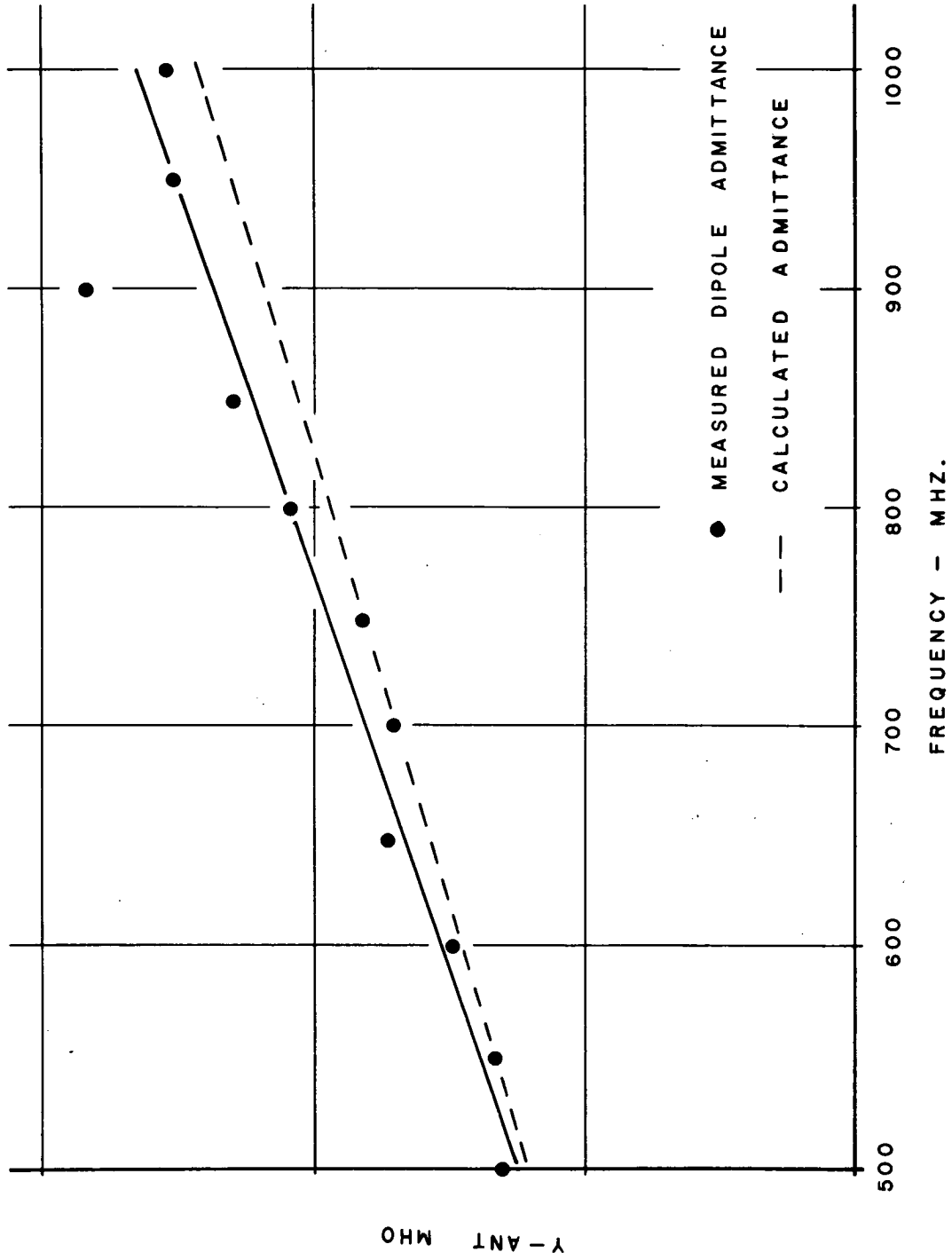

FIGURE 10. PLOT OF MEASURED AND CALCULATED FREE SPACE ADMITTANCES.

5. THE EXPERIMENTAL MEASUREMENTS

In order to make quantitative comparisons between the theoretical and experimental admittances, it is necessary to make accurate measurements of the plasma parameters. This amounts to determining the electron temperature and density. These measurements were attempted using two different probe methods. First, the single Langmuir probe method was tried (see Chen, 1965). This method proved unsatisfactory because it was found that the probe characteristic changed rapidly with time and, furthermore, that the semilog plot of the electron branch of the I-V curve was never a straight line. The second method was the floating double probe method described by Johnson and Malter (1950). This method is reportedly less sensitive to probe surface condition (contamination) than the former. However, this method also proved unsatisfactory after several measurements were made. Although the data were fairly stable and repeatable, the values of electron temperature measured were an order of magnitude higher than expected and the densities were an order of magnitude lower. The measured results were completely inconsistent with those reported, for example, by Persson.

Since no reliable method of plasma measurement could be found, only qualitative comparisons could be made. The procedure was to see whether suitable values of electron temperature and density could be substituted into the theoretical expressions to make the theoretical values "fit" the actual data. The essential feature of the data was a resonance effect where the antenna admittance became real. Since this resonance

point was well defined, it was chosen as the point where theory and data were matched exactly. It was found that the frequency of the resonance predicted by the formulas was essentially determined by the strength of the magnetic field. The magnitude of the real part of the admittance was determined primarily by the electron density and temperature. Since most of the reported data for electron temperatures for discharges of the brush cathode type cluster about 1000°K , this value was used in the formulas. Thus, only the value of electron density was manipulated. Since the magnetic field was measured fairly accurately, its value should not have had to be manipulated. However, it was found that the dependence was so sensitive that small adjustments were required to get exact matching. To reiterate, the calculated values are for an electron temperature of 1000°K and for an electron density and magnetic field such that the data value of admittance is matched at the resonance.

The antenna admittance was measured for a variety of plasmas. A data taking run consisted of maintaining the plasma discharge current and magnetic field constant and varying the frequency of measurement. The antenna was biased with respect to the anode in the vicinity of the knee of its I-V characteristic in order to break down the sheath surrounding the dipole. It was found in practice that the effect of varying bias on the admittance was very small. A set of measurements at the eleven test frequencies took approximately thirty minutes. During this time, it was usually necessary to readjust the discharge current slightly to keep it at a constant value.

Admittance measurements were made for both the parallel and perpendicular orientations. Since the dipole could not be moved while the system was under vacuum, the two orientations were measured at widely

different times (weeks). However, every attempt was made to duplicate the plasma conditions during the second set of measurements.

Representative data are presented in Figures 11 and 13, and the corresponding calculated admittances are given in Figures 12 and 14. The curve matching at the resonant point was done only for the parallel orientation. The admittances for the perpendicular orientation were then calculated using the parameters obtained for the parallel case. This should make comparisons between the two cases valid.

Aside from the fact that the theoretical curves have the same general behavior as the data (a resonance), there are two important qualitative comparisons that can be made. First, the predicted real part of the admittance approaches zero (off resonance) faster than is observed. The real parts can be made to fit better off resonance by considerably increasing the assumed electron temperature (to about 4000°K), however, then the imaginary parts begin to disagree. At higher assumed temperatures, the excursions of the imaginary part are considerably less than observed. This may point to a deficiency in the theoretical expressions, although the plasma parameters are not known well enough to draw a definite conclusion. The second comparison is more gratifying. The predicted effect of changing the orientation from parallel to perpendicular is to reduce the resonance peak of the real part and to reduce the excursion of the imaginary part. This agrees with the data quite well. The somewhat disturbing behavior of the theoretical imaginary part for frequencies below 600 MHz in Figure 12 is probably due to trouble in the calculations rather than in the formula. Although there is some predicted shifting of the resonant frequency with change in orientation, no comparisons with the data should be made. This is because the

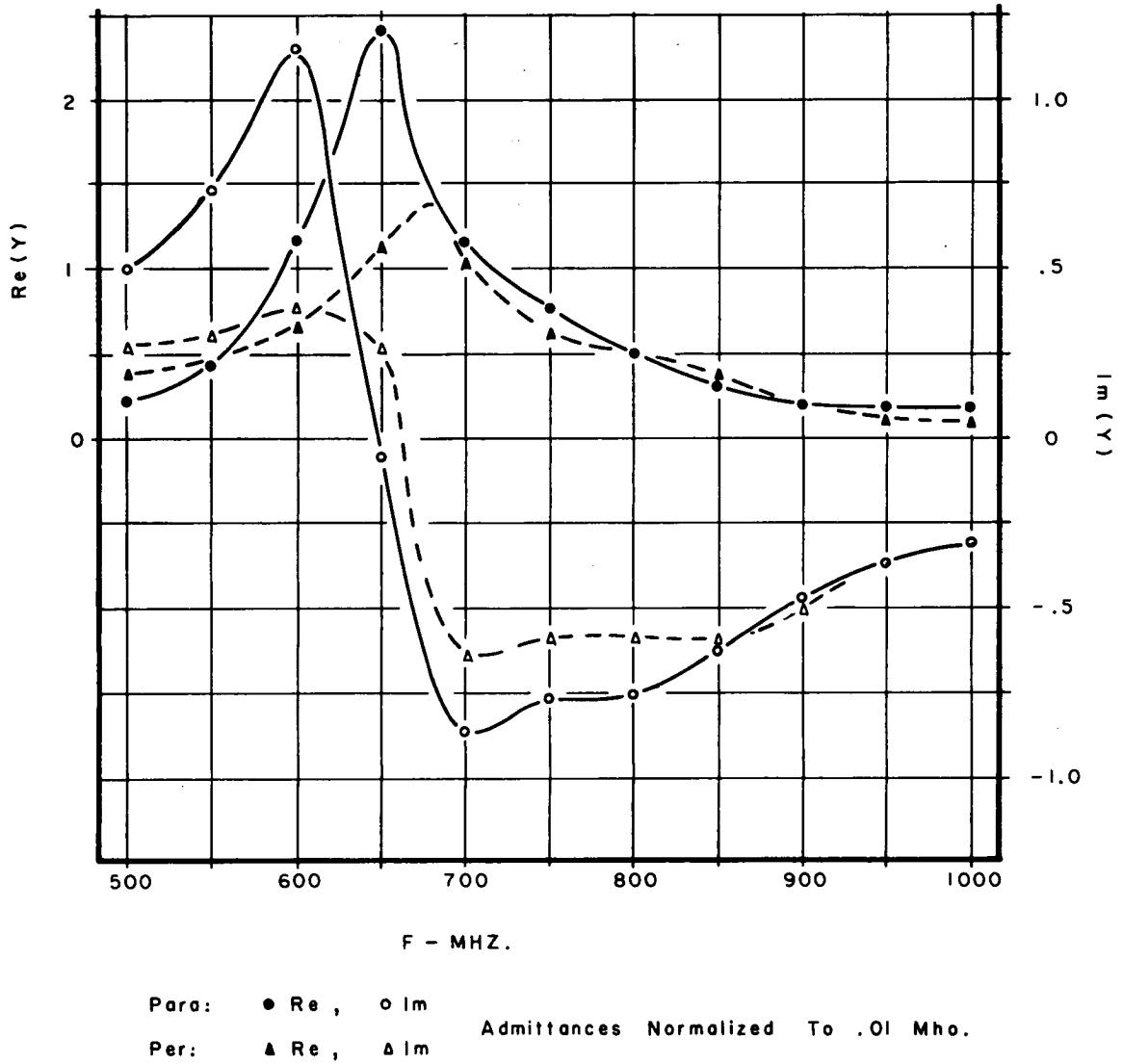

FIGURE II. MEASURED ADMITTANCES FOR THE TWO CASES. B = 256 GAUSS.

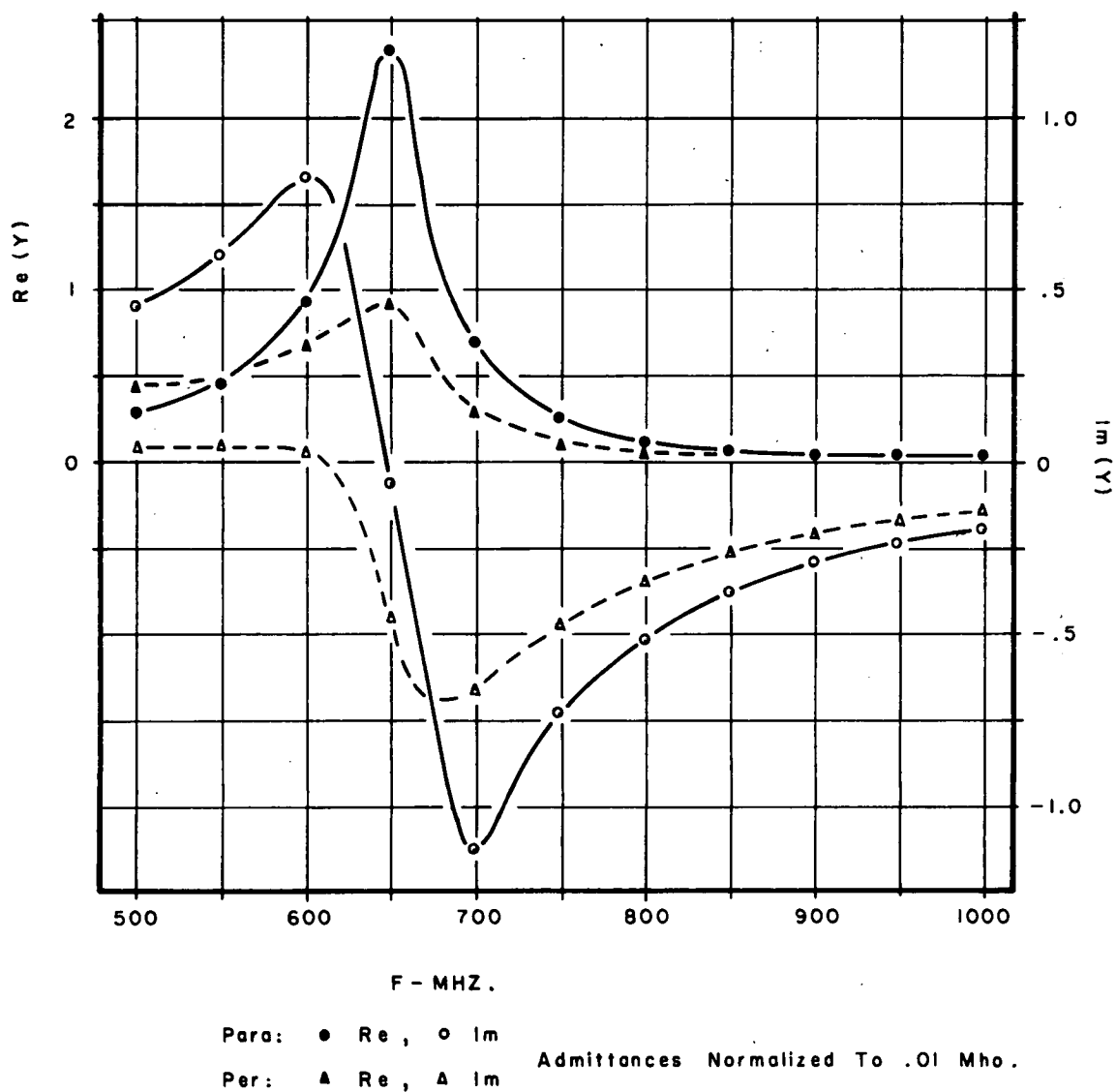

FIGURE 12. CALCULATED ADMITTANCES. CORRECTED

$$B = 229 \text{ GAUSS. } T_e = 1000^\circ \text{ K. } N_e = 2.1 \times 10^{10} / \text{cm}^3$$

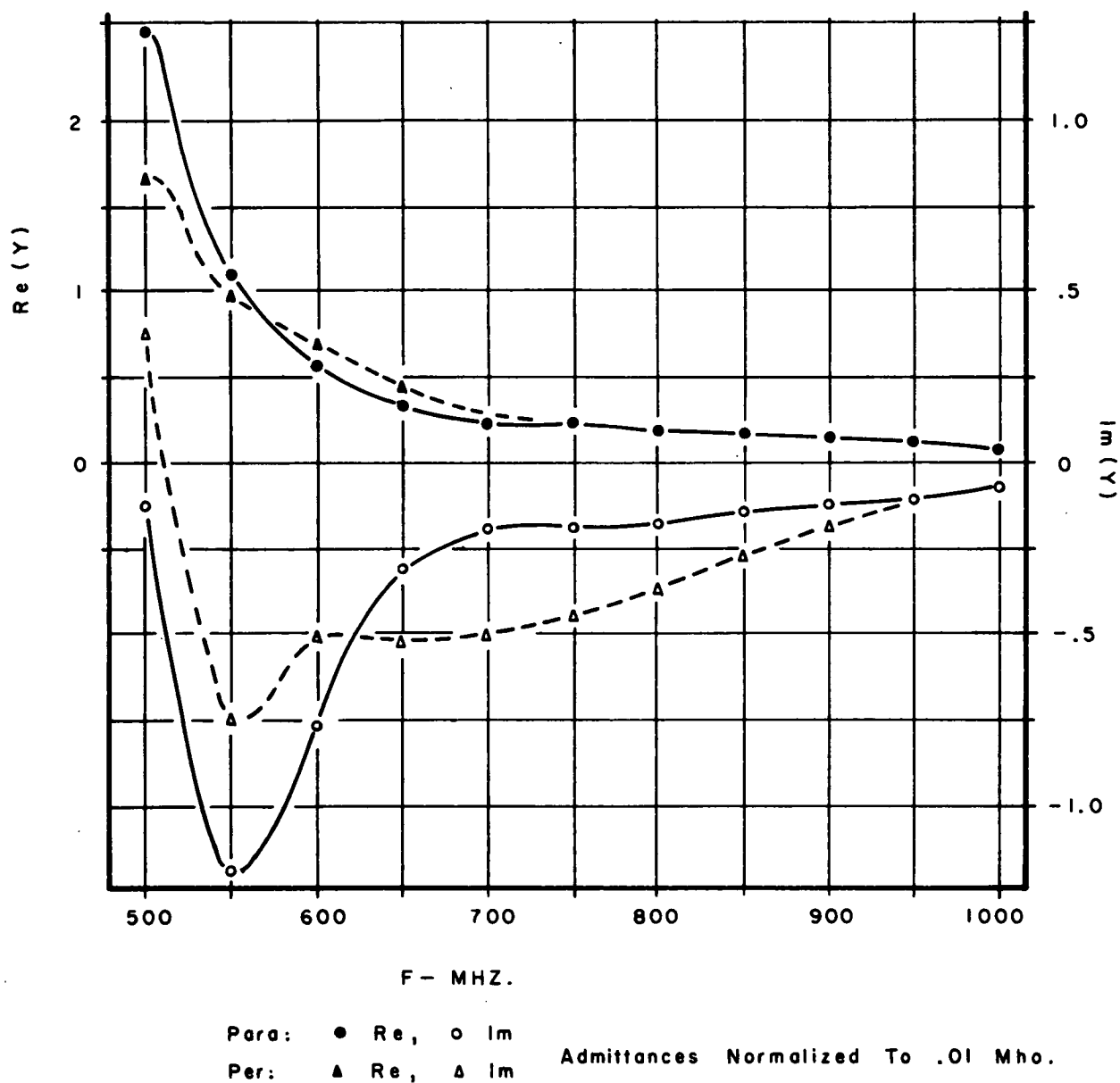
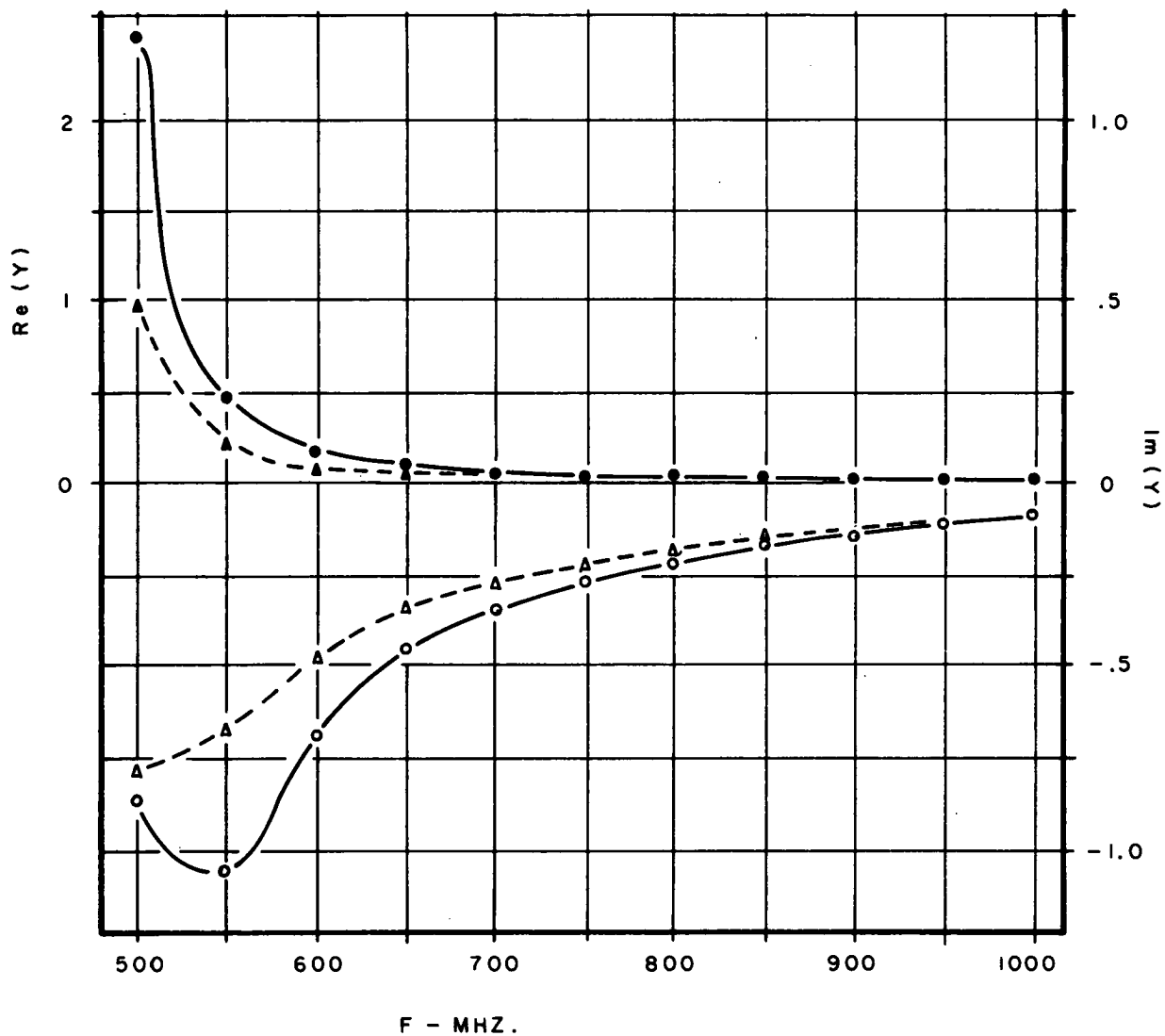

FIGURE 13. MEASURED ADMITTANCES FOR THE TWO CASES. B = 172 GAUSS.



Para: ● Re, ○ Im
Per: ▲ Re, △ Im

Admittances Normalized To .01 Mho.

FIGURE 14. CALCULATED ADMITTANCES. CORRECTED

$B = 177$ GAUSS. $T_e = 1000^\circ$ K. $N_e = 1.82 \times 10^{10} / \text{cm}^3$

magnetic field strength was not duplicated precisely enough for the second set of measurements. (Just how fast the resonant frequency varied with the field strength was not realized at the time.)

6. CONCLUSIONS

The principal conclusion that can be drawn from the data is that Balmain's (1963) formulas are useful, at least in a qualitative sense, for predicting the variation of antenna admittance with changes in antenna orientation. When the dipole orientation is changed from parallel to perpendicular, the excursions in both the real and imaginary parts of the admittance are reduced. It should be remarked, however, that there may be difficulties in applying the formulas over a wide range of frequencies for any particular antenna orientation. However, a more quantitative experiment would have to be performed in order to verify this.

It has not been possible to establish the variation of the resonant frequency with antenna orientation because the magnetic field was not measured precisely enough. The resonant frequency varies approximately linearly with the magnetic field. Thus, the relative errors in both quantities are the same. Since the predicted variation in resonant frequency with orientation is small, typically one to five percent, the magnetic field should be known with a precision of at least one percent. Likewise, the spacial variation of the magnetic field over the dimensions of the antenna should be kept below one percent. These requirements pose rather difficult experimental problems and make reliable data difficult to obtain.

The experiences with probe measurements of plasma parameters were disappointing. The main problem was contamination. However, neither

the contaminating source nor the nature of the substance could be determined. Rapidly swept probe measurements did not offer any significant improvement. Persson (1964) noted somewhat similar difficulties but he was able to overcome them by bombarding the probe with electrons for long periods.

LIST OF REFERENCES

1. Balmain, K. G., "The Impedance of a Short Dipole Antenna in a Magnetoplasma," Antenna Laboratory Report, Electrical Engineering Department, University of Illinois, Urbana, May, 1963.
2. Chen, F. F., Plasma Diagnostic Techniques, edited by R. H. Huddleston and S. L. Leonard, Academic Press, Inc., New York, Chapter 4, 1965.
3. Duff, G. L. and R. Mittra, "The Theoretical and Experimental Determination of the Input Impedance of a Small Loop of Electric Current Immersed in an Anisotropic Plasma," Antenna Laboratory Report No. 66-15, Electrical Engineering Department, University of Illinois, Urbana, October, 1966.
4. Dyson, J. D., "The Design of Conical Log-Spiral Antennas," IEEE International Convention Record, pt. 6, pp. 259-273, March, 1964.
5. Johnson, E. O. and L. Malter, "A Floating Double Probe Method for Measurements in Gas Discharges," Physical Review, v. 80, pp. 58-68, 1950.
6. Kostelnicek, R. J., "The Admittance and Resonance Probe Characteristics of a Spherical Plasma Probe," Aeronomy Report No. 8, Electrical Engineering Department, University of Illinois, Urbana, November, 1965.
7. Musal, H. M., Jr., "An Inverse Brush Cathode for the Negative-Glow Plasma Source," J.A.P., pp. 1935-1937, March, 1966.
8. Persson, K. B., "The Brush Cathode Plasma--a Well Behaved Plasma," N.B.S. Report No. 8452, September, 1964.

Unclassified

Security Classification

DOCUMENT CONTROL DATA - R&D		
<i>(Security classification of title, body of abstract and indexing annotation must be entered when the overall report is classified)</i>		
1. ORIGINATING ACTIVITY <i>(Corporate author)</i>		2a. REPORT SECURITY CLASSIFICATION
University of Illinois, Urbana, Illinois		Unclassified
		2b. GROUP
3. REPORT TITLE		
EXPERIMENTAL STUDY OF THE IMPEDANCE OF A SHORT DIPOLE IN A PLASMA FOR PARALLEL AND PERPENDICULAR ORIENTATION WITH RESPECT TO THE D.C. MAGNETIC FIELD		
4. DESCRIPTIVE NOTES <i>(Type of report and inclusive dates)</i>		
Scientific - Interim		
5. AUTHOR(S) <i>(Last name, first name, initial)</i>		
Snyder, Dan E. and Mittra, R.		
6. REPORT DATE	7a. TOTAL NO. OF PAGES	7b. NO. OF REFS
December 1968	34	8
8a. CONTRACT OR GRANT NO.	9a. ORIGINATOR'S REPORT NUMBER(S)	
NsG 395	Scientific Report No. 11	
b. PROJECT AND TASK NO.	Antenna Laboratory Report No. 68-4	
c.	9b. OTHER REPORT NO(S) <i>(Any other numbers that may be assigned this report)</i>	
d.		
10. AVAILABILITY/LIMITATION NOTICES		
11. SUPPLEMENTARY NOTES	12. SPONSORING MILITARY ACTIVITY	
13. ABSTRACT		
<p>Measurements were made of the input admittance of a small dipole immersed in a steady-state plasma with an external magnetic field. Antenna orientations parallel and perpendicular to the magnetic field were studied. The data were compared to theoretical expressions derived previously by Balmain and fairly good qualitative agreement was found.</p>		

DD FORM 1473
1 JAN 64

Unclassified

Security Classification

14. KEY WORDS	LINK A		LINK B		LINK C	
	ROLE	WT	ROLE	WT	ROLE	WT
Anisotropic Plasma Medium						
Electrically Short Dipole						
Admittance Measurements						
Effects of Orientation						

INSTRUCTIONS

1. **ORIGINATING ACTIVITY:** Enter the name and address of the contractor, subcontractor, grantee, Department of Defense activity or other organization (*corporate author*) issuing the report.
- 2a. **REPORT SECURITY CLASSIFICATION:** Enter the overall security classification of the report. Indicate whether "Restricted Data" is included. Marking is to be in accordance with appropriate security regulations.
- 2b. **GROUP:** Automatic downgrading is specified in DoD Directive 5200.10 and Armed Forces Industrial Manual. Enter the group number. Also, when applicable, show that optional markings have been used for Group 3 and Group 4 as authorized.
3. **REPORT TITLE:** Enter the complete report title in all capital letters. Titles in all cases should be unclassified. If a meaningful title cannot be selected without classification, show title classification in all capitals in parenthesis immediately following the title.
4. **DESCRIPTIVE NOTES:** If appropriate, enter the type of report, e.g., interim, progress, summary, annual, or final. Give the inclusive dates when a specific reporting period is covered.
5. **AUTHOR(S):** Enter the name(s) of author(s) as shown on or in the report. Enter last name, first name, middle initial. If military, show rank and branch of service. The name of the principal author is an absolute minimum requirement.
6. **REPORT DATE:** Enter the date of the report as day, month, year, or month, year. If more than one date appears on the report, use date of publication.
- 7a. **TOTAL NUMBER OF PAGES:** The total page count should follow normal pagination procedures, i.e., enter the number of pages containing information.
- 7b. **NUMBER OF REFERENCES:** Enter the total number of references cited in the report.
- 8a. **CONTRACT OR GRANT NUMBER:** If appropriate, enter the applicable number of the contract or grant under which the report was written.
- 8b, 8c, & 8d. **PROJECT NUMBER:** Enter the appropriate military department identification, such as project number, subproject number, system numbers, task number, etc.
- 9a. **ORIGINATOR'S REPORT NUMBER(S):** Enter the official report number by which the document will be identified and controlled by the originating activity. This number must be unique to this report.
- 9b. **OTHER REPORT NUMBER(S):** If the report has been assigned any other report numbers (*either by the originator or by the sponsor*), also enter this number(s).

10. **AVAILABILITY/LIMITATION NOTICES:** Enter any limitations on further dissemination of the report, other than those imposed by security classification, using standard statements such as:

- (1) "Qualified requesters may obtain copies of this report from DDC."
- (2) "Foreign announcement and dissemination of this report by DDC is not authorized."
- (3) "U. S. Government agencies may obtain copies of this report directly from DDC. Other qualified DDC users shall request through _____."
- (4) "U. S. military agencies may obtain copies of this report directly from DDC. Other qualified users shall request through _____."
- (5) "All distribution of this report is controlled. Qualified DDC users shall request through _____."

If the report has been furnished to the Office of Technical Services, Department of Commerce, for sale to the public, indicate this fact and enter the price, if known.

11. **SUPPLEMENTARY NOTES:** Use for additional explanatory notes.

12. **SPONSORING MILITARY ACTIVITY:** Enter the name of the departmental project office or laboratory sponsoring (*paying for*) the research and development. Include address.

13. **ABSTRACT:** Enter an abstract giving a brief and factual summary of the document indicative of the report, even though it may also appear elsewhere in the body of the technical report. If additional space is required, a continuation sheet shall be attached.

It is highly desirable that the abstract of classified reports be unclassified. Each paragraph of the abstract shall end with an indication of the military security classification of the information in the paragraph, represented as (TS), (S), (C), or (U).

There is no limitation on the length of the abstract. However, the suggested length is from 150 to 225 words.

14. **KEY WORDS:** Key words are technically meaningful terms or short phrases that characterize a report and may be used as index entries for cataloging the report. Key words must be selected so that no security classification is required. Identifiers, such as equipment model designation, trade name, military project code name, geographic location, may be used as key words but will be followed by an indication of technical context. The assignment of links, rules, and weights is optional.