

mw

①



# NASA CONTRACTOR REPORT

## NASA CR-1215

NASA CR-1215

~~CONFIDENTIAL~~  
~~FUNDS CHARGE UNIT~~

COPY ON MICROFICHE

169-16114

## THE STRUCTURAL SYNTHESIS OF AN ABLATING THERMOSTRUCTURAL PANEL

*by William A. Thornton and Lucien A. Schmit, Jr.*

*Prepared by*  
CASE WESTERN RESERVE UNIVERSITY  
Cleveland, Ohio  
*for Langley Research Center*

JAN 14 1969  
PROPERTY OF  
MCDONNELL LIBRARY  
DEPT. 218

NASA CR-1215  
TECH LIBRARY KAFB, NM



0060259

THE STRUCTURAL SYNTHESIS OF AN ABLATING  
THERMOSTRUCTURAL PANEL

By William A. Thornton and Lucien A. Schmit, Jr.

Distribution of this report is provided in the interest of information exchange. Responsibility for the contents resides in the author or organization that prepared it.

Prepared under Grant No. NsG 110-61 by  
CASE WESTERN RESERVE UNIVERSITY  
Cleveland, Ohio

for

NATIONAL AERONAUTICS AND SPACE ADMINISTRATION

---

For sale by the Clearinghouse for Federal Scientific and Technical Information  
Springfield, Virginia 22151 - CFSTI price \$3.00



## ABSTRACT

The development of a structural synthesis capability for ablating thermostructural panels in a planetary entry environment is reported. The synthesis utilizes a penalty function technique in conjunction with integrated behavior constraints. The thermal analysis includes the effects of surface recession and pyrolysis gas transpiration. The ablator layer is structural. Design variables are the layer thicknesses and panel size. Behavior constraints are the temperature at the ablator-structure interface and at the backwall, panel deflection, ablator stress, structural layer stress, intercell face buckling, and char strain. The synthesis will minimize panel weight or panel thickness. The results of twelve test cases are presented. It is found that the usual a priori assumptions about the panel thermal profiles required for minimum weight designs are not justified. The synthesis capability provides a useful tool for materials evaluation. The study should be extended to include as design variables those properties of fibrous composite structural materials which are not preassigned.



## NOMENCLATURE

a	locates neutral plane of ablator (ft)
A	reaction rate coefficient
$\Delta A/A$	solidity ratio of core material
B	reaction rate coefficient or set of behavior constraints
c	reduction factor for the parameter r of the Fiacco-McCormick function
$\bar{c}$	uniform strain in y coordinate direction
$c_p$	specific heat (Btu/lb.°R)
C	set of all constraints
$C_e$	concentration of oxygen at wall
d	locates neutral plane of entire cross-section with respect to the centroidal axis of the core (sandwich substructure only) (ft)
$d_{cell}$	diameter of honeycomb core cells (ft)
D	bending rigidity (lbs-ft)
$D_T$	bending rigidity of sandwich if core shear strain is suppressed. (lbs-ft)
$e_{xx}, e_{yy}$	total strains
$e_{xx}^e, e_{yy}^e$	elastic strains
E	Young's Modulus (lbs/ft <sup>2</sup> )
f	volatile fraction
$f_i$	minimum values of normalized behavior functions

$F(\underline{x})$	system weight or thickness
$g_i(\underline{x}, z, t)$	normalized behavior functions
$\bar{g}_i(\underline{x}, t)$	integrated normalized behavior functions
$\bar{G}_{zx}$	shear modulus of core material (lbs/ft <sup>2</sup> )
$h'$	locates neutral plane of ablator-top face composite with respect to neutral plane of whole system
$h''$	locates neutral plane of bottom face with respect to neutral plane of entire system
$h_e$	enthalpy of stream external to boundary layer (Btu/lb.)
$h_w$	enthalpy of stream at wall temperature (Btu/lb)
$H_{A,1}$	heat of ablation of $M_1$
$H_{A,2}$	heat of ablation of $M_2$
$k$	conductivity (Btu/ft-sec-°R) or structural analysis coefficient or incremental time
$k_a$	conductivity of air at mean core temperature (Btu/ft-sec. °R)
$k_e$	effective conductivity of core material (Btu/ft-sec-°R)
$K$	structural membrane stiffness (lbs/ft) or reaction rate constant
$m$	membrane stiffness ratio (sandwich case) or finite difference station corresponding to structural layer (top sandwich face).
$M$	thermal moment (lb-ft/ft)
$M_{xx}, M_{yy}$	moment resultants (lb-ft/ft)
$M_T$	thermal moment about neutral plane of entire cross- section (lbs-ft/ft)

$\dot{M}_1$	rate at which material is removed from the surface by physical removal process (lbs/ft <sup>2</sup> -sec)
$\dot{M}_2$	rate at which material, which would actually have been removed within the ablator, is assumed to be removed at the surface (lbs/ft <sup>2</sup> -sec)
n	finite difference station which corresponds to the backwall location
N	thermal force (lbs/ft)
$N_{Le}$	Lewis number
$N_{xx}, N_{yy}$	force resultants (lbs/ft)
p	applied pressure (lbs/ft <sup>2</sup> )
$p_w$	pressure at outer surface (lbs/ft <sup>2</sup> or atm.)
$P(\underline{x}, r)$	Fiacco-McCormick function
$q_c$	cold wall convective heating rate (Btu/ft <sup>2</sup> -sec.)
$q_{c,net}$	hot wall convective heating rate corrected for blocking (Btu/ft <sup>2</sup> -sec)
$\bar{Q}_{zx}$	core shear stress resultant (lbs/ft)
$Q_1, \dots, Q_5$	section properties of the composite panel (units of ft and lbs)
$Q_{m,m+1}$	heat transmitted through core (Btu/ft <sup>2</sup> -sec)
$Q', Q''$	shear stress resultants for upper and lower sandwich faces, respectively (lbs/ft)
r	Fiacco-McCormick function parameter and coefficient in solution to sandwich plate problem
s	surface recession distance (ft)



$\dot{s}$	surface recession rate (ft/sec)
$\underline{s}_i$	current search direction
$S$	set of side constraints
$t$	time (sec)
$t_f$	time required for traversing trajectory (sec)
$t', t''$	upper and lower sandwich face thicknesses, respectively (ft)
$\bar{t}$	thickness of core (ft)
$\bar{t}\hat{t}$	distance between the neutral plane of the ablator top-face composite and the centroidal plane of the lower face (ft)
$T$	temperature ( $^{\circ}R$ ) or set of all times which constitute the reentry trajectory
$T_B$	back wall temperature ( $^{\circ}R$ )
$\bar{T}_B$	maximum permitted back wall temperature ( $^{\circ}R$ )
$T_s$	structural (top face) temperature ( $^{\circ}R$ )
$\bar{T}_s$	maximum permitted structural (top-face) temperature ( $^{\circ}R$ )
$T_o$	temperature at which panel is cured ( $^{\circ}R$ )
$\bar{T}$	a dimensionless temperature associated with the core (sandwich only)
$u', u''$	membrane displacements (ft)
$u, \bar{u}$	transformed displacements (ft)
$w$	transverse displacement (ft) , positive in positive z direction

$W_{sup}$	weight of panel support system per foot of perimeter (lbs/ft)
$x, y, z$	reference coordinate system for the panel
$x_1$	initial ablator thickness (ft)
$x_2$	structural thickness (thin sheet) or thickness of top face (sandwich) (ft)
$x_3$	thickness of core (ft)
$x_4$	thickness of bottom sandwich face (ft)
$x_5$	insulation thickness (ft)
$x_6, x_7$	planform dimensions (ft)
$\underline{x}$	design space point $(x_1, x_2, x_3, x_4, x_5, x_6)$ ft.
$Z$	set of all points through the interior and at the surfaces of the panel
$\alpha$	coefficient of linear thermal expansion
$\bar{\gamma}_{zx}$	shear strain in core
$\Delta h_c$	heat of combustion of material at surface tempera- ture (Btu/lb)
$\Delta T$	$T - T_0$
$\epsilon$	emissivity
$\zeta, \eta, \xi$	coordinates used in thermal and structural analyses
$\eta_1, \eta_2$	blocking effectiveness parameters
$\lambda$	mass of material removed per unit mass of oxygen or characteristic root in homogeneous solution to sandwich plate equilibrium equations
$\nu$	Poisson's ratio

$\rho$	density (lbs/ft <sup>3</sup> )
$\sigma$	Stefan-Boltzmann constant ( $0.48 \times 10^{-12}$ Btu/ft <sup>2</sup> -sec-°R <sup>4</sup> )
$\sigma_{xx}, \sigma_{yy}$	stresses in x and y coordinate directions, respectively (lbs/ft <sup>2</sup> )
$\bar{\sigma}$	intercell face buckling stress (lbs/ft <sup>2</sup> )
$\phi_i$	normalized behavior functions

Subscripts and superscripts:

1	refers to ablator
2	refers to structure or upper face of sandwich plate
3	refers to core
4	refers to lower sandwich face
5	refers to insulator
6	refers to planform
t	quantities evaluated at present time station
t+k <sub>j</sub>	quantities evaluated at next time station
'	refers to ablator-upper sandwich face combination
"	refers to lower sandwich face
-	refers to sandwich core or to integrated behavior quantities

## TABLE OF CONTENTS

	Page
ABSTRACT	iii
NOMENCLATURE	v
CHAPTER I -- INTRODUCTION	1
A. Orientation	1
B. The thermostructural panel	1
C. The analysis	3
D. The synthesis	4
E. Closure	7
CHAPTER II -- ANALYSIS	8
A. Real system and mathematical model	8
B. Thermal analysis	9
C. Structural analysis	13
CHAPTER III -- SYNTHESIS	26
A. Behavior functions	26
B. Objective functions	31
C. Side constraints	32
D. Constraints in general	34
E. The Fiacco-McCormick function and integrated constraints	34
F. The Fletcher-Powell method	37
G. Implementation of the analysis in the synthesis	41
CHAPTER IV -- RESULTS	44
A. General	44
B. Trajectories	45
C. Materials	46
D. Documentation of the test cases	47
E. Discussion	49
CHAPTER V -- CONCLUSIONS AND RECOMMENDATIONS	114
A. Conclusions	114
B. Recommendations	117
TABLE OF WORKS CITED	120
APPENDIX A -- SIMPLIFIED ABLATION ANALYSIS	123
APPENDIX B -- SANDWICH PLATE ANALYSIS	128
APPENDIX C -- FINITE DIFFERENCE FORMULATION OF THE THERMAL ANALYSIS	148
APPENDIX D -- OPERATION OF THE COMPUTER PROGRAMS	164

## CHAPTER I

### INTRODUCTION

#### A. Orientation

The investigation reported in this document is part of a continuing research program aimed at learning how to apply the structural synthesis concept to relevant aerospace vehicle structural design problems. Structural synthesis may be viewed as a process in which sophisticated optimization techniques, drawn primarily from the mathematical programming and operations research fields, are applied to the design of a structure within a preassigned structural design concept or philosophy. The objectives of this application are (1) the complete automation of the design process (subsequent to the choice of a design concept and a preliminary design within this concept) and (2) the attainment of a final design which performs in a satisfactory manner and is optimum in some sense (minimum weight, maximum reliability, etc.). A comprehensive discussion of the ideas and terminology of structural synthesis can be found in the three volumes of summer course notes entitled "STRUCTURAL SYNTHESIS" by Schmit et al.<sup>1</sup>. These notes document, also, the results obtained by applying the structural synthesis methods to structural problems of varying complexity.

#### B. The ablating thermostructural panel design concept

The particular structural design concept which is studied in this report was selected in the spring of 1965 as the result of

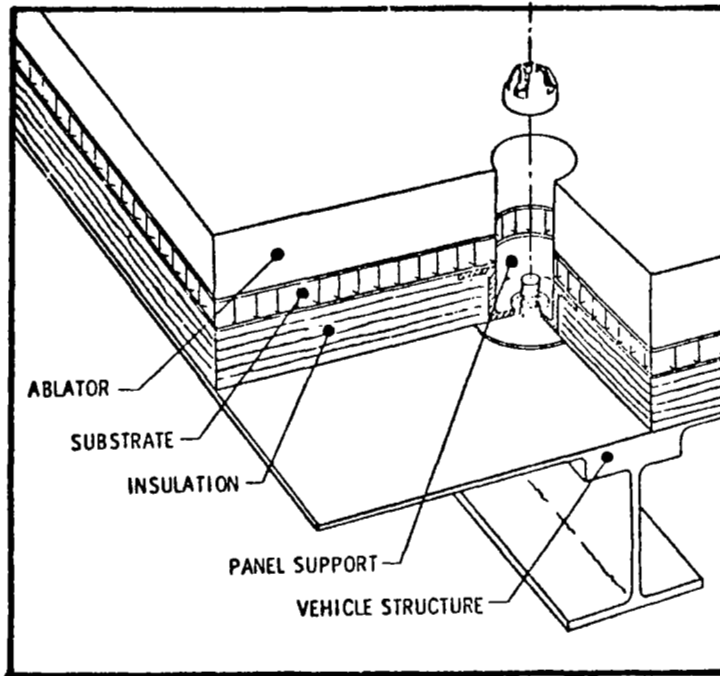

Figure 1.1 [from Laporte<sup>2</sup> ]

discussions held with representatives of NASA Langley Research Center. It is a flat rectangular panel composed of three basic layers; an ablator layer on the outside, a structural layer to which the ablator is attached, and a layer of insulation material

between the structural layer and the primary vehicle structure. The structural layer of the heat shield is attached to the primary vehicle structure. This configuration is typical of the double wall ablative heat shield concept, and it is shown in Figure 1.1. Discussion of the relative merits of the double wall concept vs. the single wall concept, in which the ablator is bonded directly to the primary vehicle structure and the insulator is placed inside the vehicle, may be found in the comprehensive reports by Laporte<sup>2</sup> and Newell<sup>3</sup>. Note that Figure 1.1 shows a panel which has point supports. In this study the panel will be continuously supported along its edges.

The structural layer can be one of two distinct types. It is either a thin sheet of structural material, or it is a honeycomb core sandwich plate. Figure 1.1 shows a sandwich structure.

A particular panel design within the double walled, ablating, thermostructural panel design concept is defined by the layer thicknesses and the planform dimensions. These are the design variables. The materials for each layer are arbitrary but preassigned; that is, they are not changed during the automated portion of design process. The panel is subjected to both thermal and mechanical loads which are derived from the particular reentry trajectory considered. The trajectory, with its associated thermal and mechanical quantities, is preassigned.

### C. The Analysis

The analysis divides naturally into two parts, (1) the transient thermal analysis and (2) the structural analysis.

(1) The transient thermal analysis assumes one dimensional heat conduction through the panel thickness. The effect of surface recession is included in the heat conduction equation. The blocking effect of the pyrolysis gases on the convective heating rate and the oxidation of the char residue at the receding ablator surface is treated. The material properties of all layers are permitted to be temperature dependent. Thermal profiles and surface recession rates for the entire trajectory are obtained.

(2) The structural analysis assumes linear elastic material behavior. The rectangular panel is idealized as an infinite strip. This permits a closed form solution for the stresses and deflections. It is assumed that panel edges are continuously supported in such a way that the transverse displacement and bending moment at the edges vanish. The ablator participates with the structural layer in

resisting the bending deformation. The structural layer may be made from either a thin sheet or a honeycomb sandwich sheet. The stresses, strains, and deflections are computed for the entire time period of the trajectory used, and the stresses and strains are computed at all pertinent positions throughout the panel thickness.

#### D. The Synthesis

The structural synthesis problem is an inequality constrained optimization problem. The best panel design, based on panel weight per square foot of vehicle surface, or on total panel thickness, is the objective. Panel weight per square foot or panel thickness is called the objective function. All possible panel designs can be thought of as being points in a "design space". The coordinates of this space are the design variables, in this case the various layer thicknesses and the planform dimension. This space has two basic regions; the region which contains all the acceptable designs and the region of all unacceptable designs. These regions are separated by a composite constraint surface. Design points just to one side of this surface are about to fail, while those just to the other side have failed.

The behavior of a particular design is determined by quantities called behavior functions. The behavior functions for the panel are:

1. temperature at the ablator-structure interface
2. temperature at the back of the insulation
3. panel midpoint deflection



4. stress in the ablator
5. stress in the structure (top and bottom sandwich faces if a sandwich plate is used).
6. intercell face buckling stress (sandwich only)
7. strain in the ablator (includes strain in the surface char layer)

Each of these quantities has an upper bound which may not be exceeded. If at any time during the trajectory or at any place throughout the panel one (or more) of these behavior functions exceeds its limiting value, the design is unacceptable because it has failed to perform satisfactorily.

Each of the above behavior functions has associated with it a set of points for which the limiting behavior function value is attained. This set of points defines the behavior constraint surface associated with the behavior function. Each behavior function has in general a unique behavior constraint surface. In addition to the behavior constraints, a design usually has its variables restricted by side constraints. The collection of behavior constraint surfaces and side constraint surfaces composes the aforementioned composite constraint surface.

The inequality constrained optimization problem of this study is converted into a series of unconstrained optimization problems through the use of a penalty function technique. Many powerful methods are available for the solution of an unconstrained optimization problem. A method developed by Fletcher and Powell<sup>4</sup> is used in

this study. The basic penalty function of Fiacco and McCormick<sup>5</sup> is used, but it is modified in a manner suggested by Zoutendijk<sup>6</sup> in order to include the contribution of the transient response in the penalty function. A further modification is introduced to include the response throughout the panel thickness in the penalty function. These modifications involve integrations of the behavior constraints over the entire time period of the trajectory and throughout the depth of the panel, thus removing the time variable and the structural location variable from the penalty function in a natural way. They eliminate the shortcoming, usual both in the study of continuous structures and in the study of structural systems subjected to transient loading, of judging the response of the system based on the critical response at one place and at one time. This shortcoming of conventional design practice is not dramatic if, in succeeding designs, the critical response of each behavior function occurs at the same structural location, and at the same time. When this does not happen, and in practice it seldom will, there is no rational way to compare the critical response of the succeeding designs. For example, the comparison of succeeding designs based on only the critical response, which occurs at different times, amounts to comparing different designs under different loadings. Also, in judging designs based on the critical response at one structural location and at one time, there is no way to distinguish between two designs having equally critical response at some location and time (not necessarily the same), one of which is critical only at

this one location and time, the other being critical over a wide range of locations and/or for a good portion of the time period considered.

#### E. Closure

This report documents the first, so far as the author knows, successful application of the integrated behavior constraint technique to a reasonably realistic continuous structure subjected to transient loading.

A priori assumptions, about which times during the trajectory the critical behavior response occurs, about the nature of the thermal profiles through the thickness of the panel (such as requiring certain temperatures to be attained at the ablator-structure interface and at the backwall), or about the specific locations through the panel at which critical stresses or strains occur, are not made. The results of the study indicate that such assumptions would not be justified.

The computer programs generated as part of this study represent a useful tool for the evaluation of the materials to be used in the several layers. Any (structurally linear elastic and isotropic) material whose thermophysical properties are known can be used simply by changing the program input data.

## CHAPTER II

### ANALYSIS

#### A. Analytical Model

The panel, as it exists in a real structure, such as part of the heat shield for the HL-10 lifting entry vehicle or the Apollo entry capsule, will be rectangular in planform (Figure 2.1) and will consist of three basic layers: an ablator, a substructure capable of transmitting the dynamic pressure loading to the primary structure,

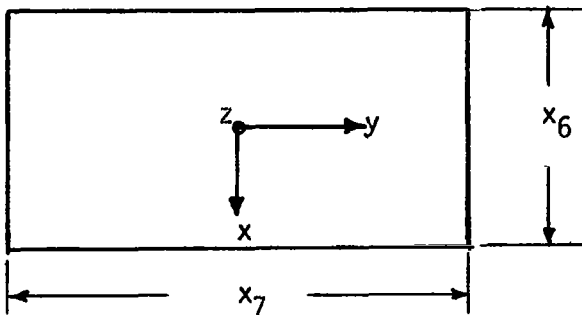

Figure 2.1

and an insulator (Figure 2.2). The ablator will be considered capable of sustaining part of the dynamic pressure loading. The substructure will consist of either a thin sheet of structural material, such as

fiberglass or aluminum, or of a honeycomb sandwich sheet. The insulator will be non-structural, notwithstanding the fact that it will provide an elastic support for the panel if packed densely enough between the

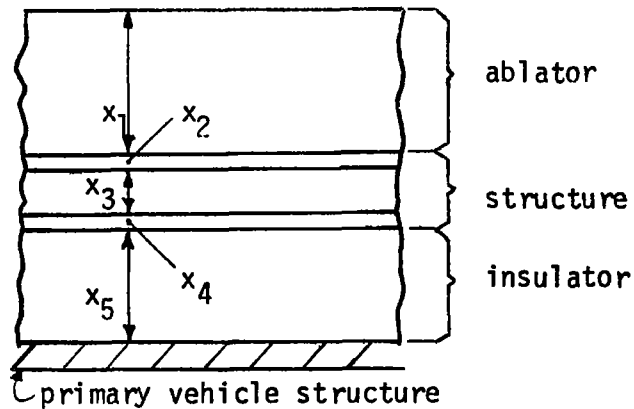

Figure 2.2

structural layer of the composite heat shield and the primary

vehicle structure.

For panels with an aspect ratio ( $AR = \frac{x_7}{x_6}$ ) of three or greater, an important simplification can be made in the structural analysis by assuming cylindrical bending. This corresponds to the case of infinite aspect ratio. The planform dimension  $x_7$  is allowed to become large with respect to the dimension  $x_6$ , so that the rectangular plate is idealized as an infinite strip. For a panel with an aspect ratio as small as three, the error in the computation of panel midpoint deflection based on an aspect ratio of  $\infty$  is about 6%. Considering the uncertainty with which any idealized set of boundary conditions and loadings are realized in applications, this error is not unacceptable.

### B. Thermal Analysis

The thermal analysis consists of a one dimensional heat conduction problem with a transient convective and radiative heating boundary condition at the outer wall. The analysis includes the effect of the pyrolysis gases

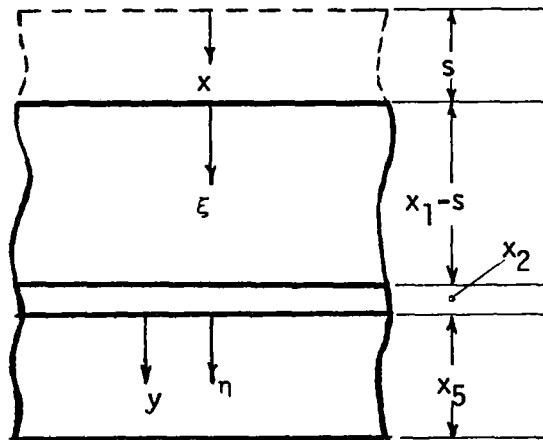

Figure 2.3

on the convective heat input. The simplified ablation analysis of Swann and Pittman,<sup>7</sup> whereby the charring ablator is treated as though it were a subliming ablator, is used.

The basic heat conduction equation for the ablator is

$$\rho_1 c_{p1} \frac{\partial T}{\partial t} = \frac{\partial}{\partial x} \left[ k_1 \frac{\partial T}{\partial x} \right] \quad s(t) < x < x_1 \quad (2.1)$$

(note that this formulation neglects all mass transfer and chemical changes within the material) where the subscript "1" refers to the ablator. In order to eliminate the moving boundary, a coordinate transformation is introduced:

$$\xi = \frac{x - s}{x_1 - s} \quad (2.2)$$

where  $s(t)$  is the total surface recession. Changing variables in eq. 2.1 yields

$$\rho_1 c_{p1} \left( \frac{\partial T}{\partial t} \right)_\xi = \left[ \frac{\dot{s}(1-\xi)}{x_1 - s} \rho_1 c_{p1} + \frac{1}{(x_1 - s)^2} \frac{\partial k_1}{\partial \xi} \right] \left( \frac{\partial T}{\partial \xi} \right)_t + \frac{k_1}{(x_1 - s)^2} \left( \frac{\partial^2 T}{\partial \xi^2} \right)_t \quad 0 < \xi < 1 \quad (2.3)$$

The boundary condition at  $\xi = 0$  is

$$q_c \left( 1 - \frac{h_w}{h_e} \right) + \dot{M}_1 \Delta h_c - (\dot{M}_1 H_{A,1} + \dot{M}_2 H_{A,2}) = \sigma \epsilon (T_1)^4 \Big|_{\xi=0} - \left( \frac{k_1}{(x_1 - s)} \frac{\partial T}{\partial \xi} \right) \Big|_{\xi=0} \quad (2.4)$$

(see Appendix A for a more complete derivation and definition of the quantities in these equations).

The structural layer, if it is a thin sheet, will be assumed to have no thermal gradient through its thickness (Figure 2.3). It will act as a heat sink, however. Thus the interface ( $\xi = 1$ ,  $n = 0$ ) condition is

$$x_2 \rho_2 c_{p2} \frac{\partial T_2}{\partial t} = - \frac{k_1}{(x_1 - s)} \frac{\partial T}{\partial \xi} + \frac{k_5}{x_5} \frac{\partial T}{\partial \eta}; \quad \xi = 1, \quad \eta = 0. \quad (2.5)$$

The subscript "2" refers to the structure, while "5" refers to the insulator. If the structure is a honeycomb sandwich panel, the interface condition is somewhat more complex (Figure 2.4). Here, the sandwich faces are assumed to have no thermal gradient through their thicknesses, but are able to store heat, while the core has a thermal gradient, but is assumed to store no heat. With these assumptions concerning the thermal behavior of the sandwich panel, only one new finite difference station must be added to that set

required for the thin sheet thermal analysis. A quantity termed the "effective thermal conductivity" is introduced for the core.<sup>8</sup> If the total heat transferred per unit area per unit time from section  $m$  to section  $m+1$  is  $Q_{m,m+1}$  (See Figure 2.4), then the effective conductivity of the core,  $k_e$ , is related to  $Q_{m,m+1}$  and the temperature difference between  $m$  and  $m+1$ , as

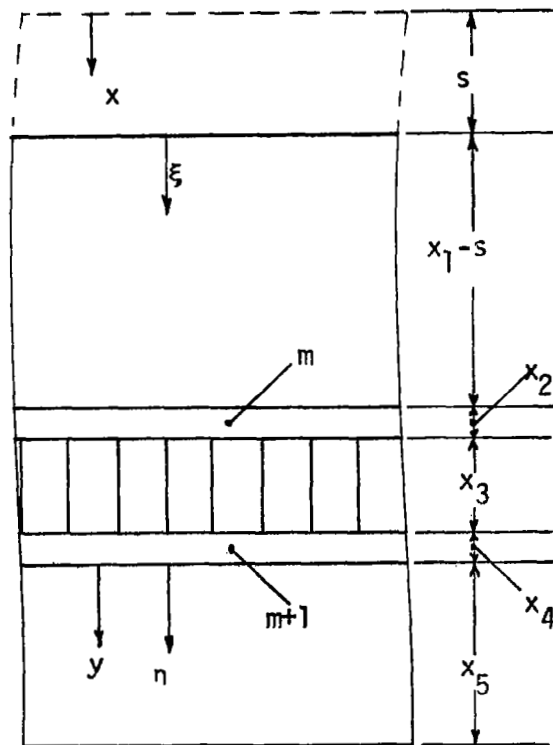

Figure 2.4

$$Q_{m,m+1} = \frac{k_e + k_a}{x_3} [T_m - T_{m+1}] \quad (2.6)$$

where  $k_a$  is the conductivity of the air in the honeycomb core. Swann and Pittman<sup>8</sup> have derived an approximate expression for  $k_e$ :

$$k_e = \frac{\Delta A}{A} k_c [1.0 + 0.664 (\lambda + 0.3)^{-0.69} \epsilon^{1.63} (1 + \lambda)^{-0.89} (T_m^2 + T_{m+1}^2)(T_m + T_{m+1})]$$

where

$\lambda = \frac{x_3}{d_{\text{cell}}}$ , the ratio of core depth of cell diameter,  $\epsilon$  is the core emissivity,  $k_c$  is the conductivity of the core material evaluated at the mean core temperature,  $\frac{\Delta A}{A}$  is the solidity ratio of the core, and  $\bar{T}_m = \left(\frac{\sigma x_3}{k_c} \frac{A}{\Delta A}\right)^{1/3} T_m$  is a dimensionless temperature.

Based on the assumed thermal behavior of the core, the interface condition consists of the following two heat balance equations:

$$x_2 \rho_2 c_{p2} \frac{\partial T_m}{\partial t} = - \frac{k_1}{(x_1 - s)} \frac{\partial T_m}{\partial \xi} - Q_{m,m+1} \quad (2.7)$$

$$x_4 \rho_4 c_{p4} \frac{\partial T_{m+1}}{\partial t} = \frac{k_5}{x_5} \frac{\partial T_{m+1}}{\partial \eta} + Q_{m,m+1} \quad (2.8)$$

In the insulator a normalized coordinate  $\eta$  is introduced,

$$\eta = \frac{y}{x_5} \quad (2.9)$$



The field equation for the insulator is

$$\rho_5 c_{p5} \frac{\partial T}{\partial t} = \frac{k_5}{x_5^2} \frac{\partial^2 T}{\partial n^2} + \left( \frac{1}{x_5^2} \frac{\partial k_5}{\partial n} \right) \frac{\partial T}{\partial n}; \quad 0 < n < 1 \quad (2.10)$$

At the back face, the wall is assumed to be perfectly insulated,

$$\frac{\partial T}{\partial n} = 0, \quad n = 1 \quad (2.11)$$

The simultaneous solution of eqs. (2.3), (2.4), (2.5) or (2.7) and (2.8), (2.10) and (2.11) yields the thermal distribution throughout the thickness of the panel. These equations are programmed in implicit finite difference form. (See Appendix C). The thermal distribution is used as an input to the stress and deflection calculations.

### C. Structural Analysis

The insulation is assumed to have no strength. The ablator has significant strength at low to moderate temperatures. The structural layer will consist of either a simple thin sheet of structural material, or a sandwich plate made up of two facings and a low density core.

## 1. Thin Sheet

The reference plane is taken to be at the center of the thin sheet. The neutral plane of the composite panel is located a distance "a" above the reference plane. Details are shown in Figure 2.5.

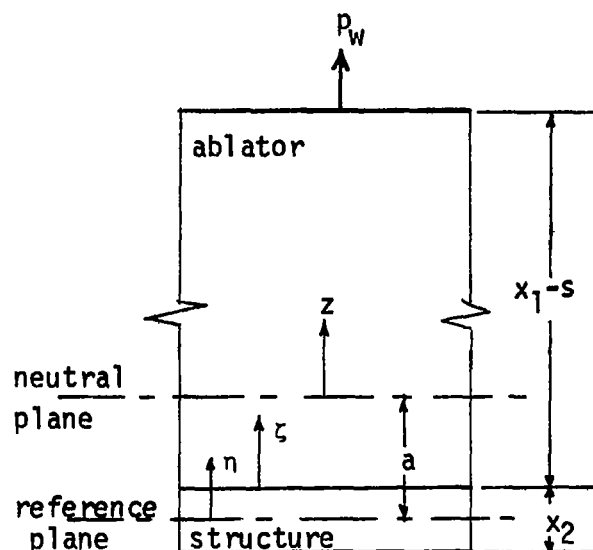

Figure 2.5

The materials of all layers are assumed to obey a linear elastic stress-strain law. Also, the Poisson's ratios for all the materials are assumed to have the same value. The materials are isotropic.

The panel length in the  $y$  coordinate direction is assumed very large so that mathematically it can be treated as infinity. The panel is allowed to expand to the  $y$  direction, but curvature is suppressed. Thus the strain in the  $y$  direction,  $e_{yy}$ , is constant, and can be written as

$$e_{yy} = \bar{c} \quad (2.12)$$

with  $\bar{c}$  an as yet undetermined coefficient.

The stress-strain law is as follows, with  $e_{xx}$  and  $e_{yy}$  representing the total strains at a point. The total strains are the sum of the elastic strains ( $e_{xx}^e$  and  $e_{yy}^e$ ) and the thermal strains.

$$\begin{aligned}\sigma_{xx} &= \frac{E}{1-\nu^2} [e_{xx} + \nu e_{yy}] - \frac{E\alpha(\Delta T)}{1-\nu} \\ \sigma_{yy} &= \frac{E}{1-\nu^2} [e_{yy} + \nu e_{xx}] - \frac{E\alpha(\Delta T)}{1-\nu} \\ \sigma_{xy} &= 0\end{aligned}\tag{2.13}$$

The quantity  $\Delta T = T - T_0$ , where  $T_0$  is the temperature at which the composite panel is cured (350°F for a phenolic nylon ablator material).<sup>9</sup>

The usual hypothesis concerning plane sections remaining plane is used. This requires that the displacement in the x coordinate direction vary linearly through the cross-section, as

$$u = u^0 - z w_{,x}\tag{2.14}$$

and

$$e_{xx} = \frac{du}{dx} = \frac{du^0}{dx} - z \frac{d^2w}{dx^2}\tag{2.15}$$

The stress-strain law becomes

$$\begin{aligned}\sigma_{xx} &= \frac{E}{1-\nu^2} [u'_{,x} - z w_{,xx} + \nu \bar{c}] - \frac{E\alpha(\Delta T)}{1-\nu} \\ \sigma_{yy} &= \frac{E}{1-\nu^2} [\bar{c} + \nu (u'_{,x} - z w_{,xx})] - \frac{E\alpha(\Delta T)}{1-\nu}\end{aligned}\tag{2.16}$$

Force and moment resultants are defined as

$$\begin{aligned}
N_{xx} &= \int \sigma_{xx} dz = K [u'_{,x} + v \bar{c}] - N \\
N_{yy} &= \int \sigma_{yy} dz = K [\bar{c} + v u'_{,x}] - N \\
M_{xx} &= \int \sigma_{xx} z dz = -D w_{,xx} - M \\
M_{yy} &= \int \sigma_{yy} z dz = -v D w_{,xx} - M
\end{aligned} \tag{2.17}$$

where

$$\begin{aligned}
K &= \frac{1}{1-\nu^2} \int E dz \\
D &= \frac{1}{1-\nu^2} \int E z^2 dz \\
N &= \frac{1}{1-\nu} \int E \alpha (\Delta T) dz \\
M &= \frac{1}{1-\nu} \int E \alpha (\Delta T) z dz
\end{aligned} \tag{2.18}$$

The differential equation for vertical equilibrium is

$$D w_{,xxxx} = p_w \tag{2.19}$$

where  $p_w$  is the uniformly distributed loading, positive when directed in the positive  $z$  direction.

The origin for the  $x$  coordinate will be taken at the center of the panel. Hence the boundary conditions will be applied at  $\pm \frac{x_0}{2} \equiv \pm \ell$ . The panel is simply supported at  $x = \pm \ell$ . This gives

$$w(\pm \ell) = 0 \quad (2.20a)$$

and

$$M_{xx}(\pm \ell) = 0 \quad (2.20b)$$

as boundary conditions.

The panel is allowed to expand without restriction, so that

$$N_{xx} = N_{yy} = 0 \quad (2.21)$$

Using eqs. (2.17) and (2.21), it can be shown that

$$u'_{,x} \equiv \bar{c} = \left( \frac{1}{1+\nu} \right) \frac{N}{K} \quad (2.22)$$

The complete solution to eq. (2.19) is

$$w(x) = \frac{1}{24} \frac{p_w}{D} x^4 + c_1 x^3 + c_2 x^2 + c_3 x + c_4 \quad (2.23)$$

but because both the structure and the loading are symmetric functions of  $x$ , the response must also be symmetric (an even function) in  $x$ , so that eq. (2.23) is reduced to

$$w(x) = \frac{1}{24} \frac{p_w}{D} x^4 + c_2 x^2 + c_4 \quad (2.24)$$

The boundary conditions (2.20) need only be applied at either  $x = + \ell$  or  $x = - \ell$ . Applying them at  $x = + \ell$ , the solution for  $w$  at  $x = 0$  is

$$w(0) = \frac{1}{8D} \left[ M + \frac{40}{384} p_w x_4^2 \right] x_6^2 \quad (2.25)$$

while the curvature at  $x = 0$

$$w_{,xx}(0) = -\frac{1}{D} \left[ M + \frac{1}{8} x_6^2 p_w \right] \quad (2.26)$$

Equations (2.22), (2.25) and (2.26) allow the computation of stresses and displacements at the center of the panel.

The location of the neutral axis is given by

$$\int E z \, dz = 0 \quad (2.27)$$

Thus,

$$\int E z \, dz = \int E (n-a) \, dn = \int E n \, dn - a \int E \, dn$$

Defining  $Q_1 = \int E \, dn = x_2 E_2 + \int_0^{x_1-s} E_1 \, dz$  (2.28)

$$Q_2 = \int E n \, dn = \int_0^{x_1-s} E_1 \left( z + \frac{x_2}{2} \right) dz \quad (2.29)$$

"a" can be written as

$$a = \frac{Q_2}{Q_1} \quad (2.30)$$

Note that  $K = \rho_1 / (1-\nu^2)$ . (2.31)

To evaluate D;

$$D = \frac{1}{1-v^2} \int E z^2 dz = \frac{1}{1-v^2} \int E(n-a)^2 dn$$

$$= \frac{1}{1-v^2} \left( \int E n^2 dn - 2a \int E n dn + a^2 \int E dn \right).$$

Thus, after defining

$$Q_3 \equiv \int E n^2 dn = \frac{1}{12} E_2 x_2^3 + \int_0^{x_1-s} E_1 \left( \zeta + \frac{x_2}{2} \right)^2 d\zeta. \quad (2.32)$$

It is found that

$$D = \frac{1}{1-v^2} \left( Q_3 - 2 \left( \frac{Q_2}{Q_1} \right) Q_2 + \left( \frac{Q_2}{Q_1} \right)^2 Q_1 \right) = \frac{1}{1-v^2} (Q_3 - a Q_2). \quad (2.33)$$

Finally, to evaluate N and M

$$M = \frac{1}{1-v} \left[ \int E \alpha (\Delta T) (n-a) dn \right]$$

define

$$Q_4 \equiv \frac{1}{1-v} \int E \alpha (\Delta T) dn = \frac{1}{1-v} \int_0^{x_1-s} E_1 \alpha_1 (\Delta T)_1 d\zeta \quad (2.34)$$

$$Q_5 \equiv \frac{1}{1-v} \int n E \alpha (\Delta T) dn = \frac{1}{1-v} \int_0^{x_1-s} E_1 \alpha_1 (\Delta T)_1 \left( \zeta + \frac{x_2}{2} \right) d\zeta. \quad (2.35)$$

$$\text{Thus} \quad N = Q_4 \quad (2.36)$$

$$M = Q_5 - a Q_4 \quad (2.37)$$

## 2. Sandwich Sheet

A detailed sandwich plate analysis is presented in Appendix B. A brief description of the analysis will be given here. The notation used in the ensuing analysis follows that of Ebcioğlu.<sup>10</sup> The bending rigidity of the faces is retained and the following assumptions are used

1. Face to core bond failure does not occur.
2. Core is homogeneous and cell size is much smaller than panel size.
3. Transverse shear deformation of the faces and the ablator is negligible.
4. Poisson's ratio for all materials is the same.
5. Only the transverse normal and shear stresses exist in the core.
6. Transverse normal strains in the core are negligible.
7. There is no thermal gradient in the sandwich faces.  
(There is a gradient in the ablator.)
8. There is no slippage or bond failure between the upper face and the ablator.



Figure 2.6 shows some of the pertinent geometrical quantities. Primed quantities refer to the upper face, which is composed of the ablator and the upper sandwich face, while double primed quantities refer to the lower sandwich face. Both  $x_2$  and  $t'$  denote the thickness of the upper sandwich face,  $\bar{t}$  and  $x_3$  denote the core thickness, and  $x_4$  and  $t''$  refer to the thickness of the lower sandwich face. The coordinate  $z''$  is measured from

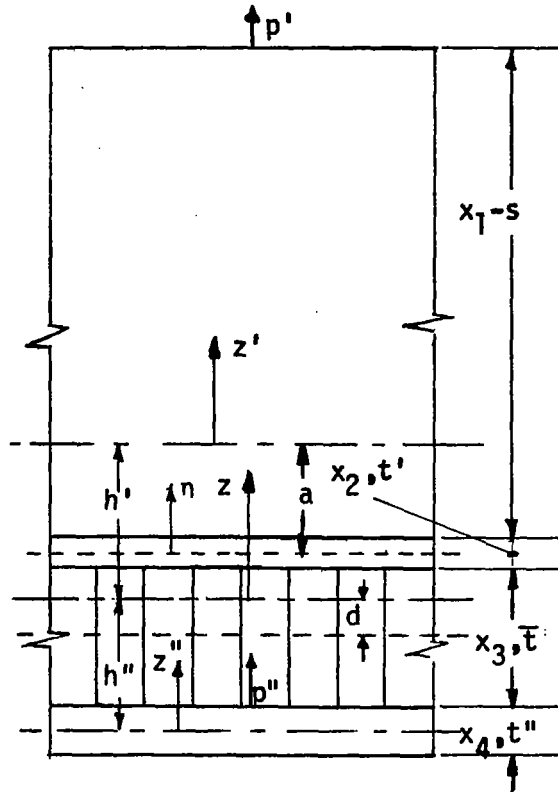

Figure 2.6

the centroidal axis of the lower face (since the lower face has no thermal gradient, this corresponds to the neutral axis), and  $z$  is measured from the neutral axis of the entire cross section. These coordinate reference planes are determined by evaluating the following integrals:

For  $z'$  :

$$\int_{A'} Ez' dz = 0 \quad (2.38)$$

For  $z''$  :

$$\int_{A''} Ez'' dz'' = 0 \quad (2.39)$$

For  $z$  :

$$\int_A E z dz = 0 \quad (2.40)$$

where  $A'$  is the cross-sectional area of the upper composite face (unit length in the  $y$  direction),  $A''$  is the area of the lower face, and  $A$  is the area of the entire cross-section.

The distance " $d$ " locates the neutral plane of the entire cross-section with respect to the geometric center of the core, and " $a$ " is the same as in the thin sheet analysis.

Figure 2.7 shows the deformation of the composite panel.  $u'$  and  $u''$  are the in-plane displacements at the neutral planes of the top and bottom faces, respectively. The displacement variation through the upper face is given by

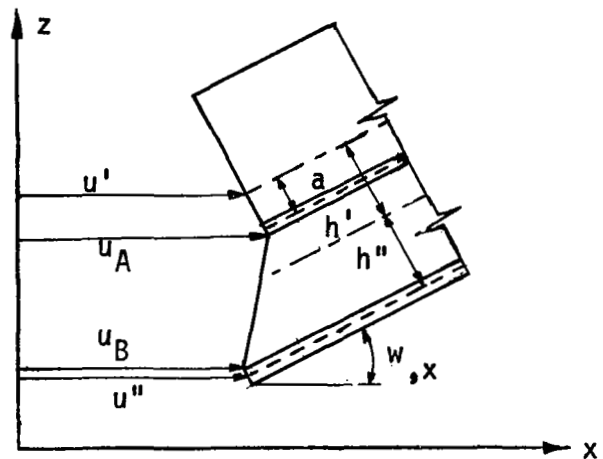

Figure 2.7

$$u(x, z') = u'(x) - z' w_{,x}(x) \quad (2.41)$$

while for the lower face

$$u(x, z'') = u''(x) - z'' w_{,x}(x) \quad (2.42)$$

The stress-strain equations for each face are the same as those given by eqs. (2.13) of the thin sheet analysis and force and moment resultants can be defined in a manner similar to those defined for

the thin sheet. (See eqs. B-6)

The system of differential equations which describes the behavior of the sandwich plate is

$$\bar{u}_{,xx} = 0 \quad -l < x < +l \quad (2.43)$$

$$k_1 u_{,xx} - \bar{t} \hat{t} w_{,x} - u = 0 \quad -l < x < l \quad (2.44)$$

$$k_2 w_{,xxxx} - \bar{t} \hat{t} w_{,xx} - u_{,x} = p_w$$

These are equilibrium equations in terms of displacement variables. Eq. (2.43) is a membrane equilibrium equation; eqs. (2.44) describe the bending of the plate including transverse shear deformation in the core. The boundary conditions, for a simply supported panel which is permitted to expand freely, are

$$N_{xx} = K' [\bar{u}_{,x} + \nu \left(\frac{1+m}{m}\right) \bar{c}] - N = 0 \quad x = \pm l \quad (2.45)$$

$$N_{yy} = K' \left[ \left(\frac{1+m}{m}\right) \bar{c} + \nu \bar{u}_{,x} \right] - N = 0$$

$$M_{xx} = -k_3 w_{,xx} + k_4 u_{,x} - M_T = 0 \quad x = \pm l \quad (2.46)$$

$$w = 0$$

$$\bar{\gamma}_{zx} = \bar{G}_{zx} [\bar{t} \hat{t} w_{,x} + u] = 0$$

The parameters  $k_1, k_2, \hat{c}, m, K', \bar{c}, k_3, k_4, N,$  and  $M_T$  in these equations are defined in Appendix B. The variables are defined as

$$\bar{u} = u' + \frac{1}{m} u'' \quad (2.47)$$

$$u = u' - u''$$

These variables occur in a natural manner in the boundary conditions. They are implicit in the original field equations (eqs. B-46) and can be made explicit in the field equations, as in eqs. (2.43) and (2.44), by simple algebraic operations. See Appendix B for details. Because of the form of field equations (2.43) and (2.44) and the boundary conditions (2.45) and (2.46), the variable  $\bar{u}$ , and the variables  $u$  and  $w$ , can be obtained independently of each other. Thus, from (2.43) and (2.45)

$$\bar{u}(x) = \frac{1}{1+\nu} \left( \frac{m}{1+m} \right) \frac{N}{K'} x \quad (2.48)$$

$$\bar{c} = \frac{1}{1+\nu} \left( \frac{m}{1+m} \right) \frac{N}{K'} \quad (2.49)$$

while from (2.44) and (2.46)

$$u(x) = \alpha A_1 \sinh rx - 2 \bar{c} \hat{t} A_3 x + u_p(x) \quad (2.50)$$

$$w(x) = A_1 \cosh rx + A_2 + A_3 x^2 + w_p(x) \quad (2.51)$$

$w_p(x)$  and  $u_p(x)$  are particular solutions of equations (2.44), depending on the loading term  $p_w$ . The coefficients  $A_1, A_2,$  and  $A_3$  are determined from the equations (2.46). Their values are given in Appendix B, by equations (B70), (B71) and (B67), respectively.

When the deflections are known, the stresses can be determined from the stress-displacement equations as

$$\sigma'_{xx} = \frac{E}{1-\nu^2} [u'_{,x} - z' w_{,xx} + \nu \bar{c}] - \frac{E' \alpha' (\Delta T)'}{1-\nu} \quad (2.52)$$

$$\sigma'_{yy} = \frac{E}{1-\nu^2} [\bar{c} + \nu (u'_{,x} - z' w_{,xx})] - \frac{E' \alpha' (\Delta T)'}{1-\nu} \quad (2.53)$$

$$\bar{\sigma}_{zx} = \frac{\bar{G}_{zx}}{\bar{t}} [\bar{t} \hat{t} w_{,x} + (u' - u'')] \quad (2.54)$$

Equations similar to (2.52) and (2.53) can be written for the lower sandwich face. See eqs. (B72). These stresses are used in the Von Mises yield criterion to predict failure.

## CHAPTER III

### SYNTHESIS

#### A. Behavior Functions

The results of the foregoing thermal and stress analyses are used to predict the behavior of the model. The derived equations relating temperatures, deflections, stresses, and strains to the design variables, time, and location within the structure are called behavior functions. The behavior functions for the case of a thin sheet structural layer are

1. temperature at the structural layer
2. temperature at the back of the insulator
3. panel midpoint deflection
4. panel stress
5. stress in the ablator at low to moderate temperatures
6. tensile strain in the ablator
7. compressive strain in the ablator

These seven can be written in explicit normalized form as

( $\underline{x}$  is the current design space point,  $n$  locates position through the panel cross-section, and  $t$  is time):

$$\phi_1(\underline{x}, t) = T_s(\underline{x}, t) / \bar{T}_s \quad 0 \leq t \leq t_f \quad (3.1)$$

$$\phi_2(\underline{x}, t) = T_B(\underline{x}, t) / \bar{T}_B \quad 0 \leq t \leq t_f \quad (3.2)$$

$$\phi_3(\underline{x}, t) = w(\underline{x}, t) / \bar{w} \quad 0 \leq t \leq t_f \quad (3.3)$$

$\bar{T}_S$ ,  $\bar{T}_B$  and  $\bar{w}$  are the prescribed critical values for structural temperature, back wall temperature, and midpoint deflection, respectively.

Yielding in the panel is governed by the Von Mises criterion.

Thus

$$\phi_4(\underline{x}, n, t) = \frac{\sigma_x^2(\underline{x}, n, t) - \sigma_x(\underline{x}, n, t) \sigma_y(\underline{x}, n, t) + \sigma_y^2(\underline{x}, n, t)}{\bar{\sigma}_Y^2(n, t)}$$

$$-\frac{x_2}{2} \leq n \leq \frac{x_2}{2}; \quad 0 \leq t \leq t_f \quad (3.4)$$

$\bar{\sigma}_Y(n, t)$  is the uniaxial yield stress, assumed to be the same for tension and compression.

Ablator yielding will be determined by a generalized yield criterion<sup>11</sup> which reduces to the Von Mises criterion when the tensile and compressive uniaxial yield stress are equal. This generalized yield criterion is necessary because the ablator materials exhibit yield stresses which are different under tension and compression. Thus, if, for example  $\sigma_x(\underline{x}, n, t) > 0$  and  $\sigma_y(\underline{x}, n, t) < 0$ , the normalized behavior function for ablator yielding is

$$\phi_5(\underline{x}, n, t) = \left[ \left( \frac{\sigma_x(\underline{x}, n, t)}{\bar{\sigma}_T(n, t)} \right)^2 - \frac{\sigma_x(\underline{x}, n, t) \sigma_y(\underline{x}, n, t)}{\bar{\sigma}_T(n, t) \bar{\sigma}_C(n, t)} + \left( \frac{\sigma_y(\underline{x}, n, t)}{\bar{\sigma}_C(n, t)} \right)^2 \right]$$

$$\frac{x_2}{2} \leq n \leq (x_1 - s) + \frac{x_2}{2} \quad 0 \leq t \leq t_f \quad (3.5)$$

$\bar{\sigma}_T(n,t)$  is the uniaxial yield stress in tension, and  $\bar{\sigma}_C(n,t)$  is the uniaxial yield stress in compression. In this formulation, both  $\bar{\sigma}_T$  and  $\bar{\sigma}_C$  are positive numbers.

For ablator strain, the normalized behavior functions consist of ratios of actual strain to critical strain. Thus

$$\phi_6(\underline{x},n,t) = \frac{e_{xx_T}(\underline{x},n,t)}{\bar{e}_T(n,t)} \quad \begin{array}{l} \frac{x_2}{2} \leq n \leq \frac{x_2}{2} + (x_1-s) \\ 0 \leq t \leq t_f \end{array} \quad (3.6)$$

$$\phi_7(x,n,t) = \frac{|e_{xx_C}(\underline{x},n,t)|}{\bar{e}_C(n,t)} \quad \begin{array}{l} \frac{x_2}{2} \leq n \leq \frac{x_2}{2} + (x_1-s) \\ 0 \leq t \leq t_f \end{array} \quad (3.7)$$

$\bar{e}_T$  is the ultimate allowable tensile strain, and  $\bar{e}_C$  is the ultimate allowable compressive strain. Because of bending, the strain in the x-coordinate direction will govern the design.  $\bar{e}_T$  and  $\bar{e}_C$  both are positive numbers.

The behavior functions for the case of a sandwich structural layer are

1. temperature of the upper sandwich face
2. temperature at the back of the insulation
3. deflection at the midpoint of the panel
- 4,5. yield stress in the structural layer (for the sandwich structure, both upper and lower faces are considered separately).



6. intercell face buckling stress
7. yield stress in the ablator at low to moderate temperatures
8. tensile strain in the ablator
9. compressive strain in the ablator

Let the set of behavior constraints be denoted by B. Then B for the thin sheet structure composite will contain 7 elements, and B for the sandwich structure composite will contain 9 elements.

The behavior constraints for the sandwich structure case can be written in an explicit normalized form as follows, with  $\underline{x}$  denoting the current design space point,  $n$  and  $z$  as dummy thickness variables and  $t$  as the time:

$$\phi_1(\underline{x}, t) = T_S(\underline{x}, t) / \bar{T}_S \quad 0 \leq t \leq t_f \quad (3.9)$$

$$\phi_2(\underline{x}, t) = T_B(\underline{x}, t) / \bar{T}_B \quad 0 \leq t \leq t_f \quad (3.10)$$

$$\phi_3(\underline{x}, t) = w(\underline{x}, t) / \bar{w} \quad 0 \leq t \leq t_f \quad (3.11)$$

$$\phi_4(\underline{x}, n, t) = \left[ \frac{\sigma_x^2(\underline{x}, n, t) - \sigma_x(\underline{x}, n, t) \sigma_y(\underline{x}, n, t) + \sigma_y^2(\underline{x}, n, t)}{\bar{\sigma}_y^2(n, t)} \right] \quad (3.12)$$

$$-\frac{x_2}{2} \leq n \leq \frac{x_2}{2} \quad 0 \leq t \leq t_f$$

$$\phi_5(\underline{x}, z'', t) = \left[ \frac{\sigma_x^2(\underline{x}, z'', t) - \sigma_x(\underline{x}, z'', t) \sigma_y(\underline{x}, z'', t) + \sigma_y^2(\underline{x}, z'', t)}{\bar{\sigma}^2} \right]$$

$$-\frac{x_4}{2} \leq z'' \leq \frac{x_4}{2} \quad 0 \leq t \leq t_f \quad (3.13)$$

$$\phi_6(\underline{x}, t) = \frac{1}{\bar{\sigma}} \max [-\sigma_x(\underline{x}, n, t), -\sigma_y(\underline{x}, n, t)]; \quad n = 0 \quad (3.14)$$

$$0 \leq t \leq t_f$$

where <sup>12</sup>  $\bar{\sigma} = 3 E_2 \left( \frac{x_2}{d_{\text{cell}}} \right)^2$  (3.15)

and  $d_{\text{cell}}$  = diameter of honeycomb core cells. This constraint applies only when  $\phi_6(\underline{x}, t) > 0$ .

For ablator yield stress, the remarks made in conjunction with eq. (3.5) apply verbatim for the sandwich case. Thus, for example if,  $\sigma_x < 0$  and  $\sigma_y < 0$ ,

$$\phi_7(\underline{x}, n, t) = \left[ \left( \frac{\sigma_x(\underline{x}, n, t)}{\bar{\sigma}_c(n, t)} \right)^2 - \frac{\sigma_x(\underline{x}, n, t)}{\bar{\sigma}_c(n, t)} \frac{\sigma_y(\underline{x}, n, t)}{\bar{\sigma}_c(n, t)} + \left( \frac{\sigma_y(\underline{x}, n, t)}{\bar{\sigma}_c(n, t)} \right)^2 \right] \quad (3.16)$$

$$\frac{x_2}{2} \leq n \leq \frac{x_2}{2} + (x_1 - s) \quad 0 \leq t \leq t_f$$

As before,  $\bar{\sigma}_c$  is a positive number.

The ablator strain is controlled by the following expressions:

$$\phi_8(\underline{x}, n, t) = \frac{e_{xx_T}(\underline{x}, n, t)}{\bar{e}_T(n, t)} ; \quad \frac{x_2}{2} \leq n \leq \frac{x_2}{2} + (x_1 - s)$$

$$0 \leq t \leq t_f \quad (3.17)$$

$$\phi_9(\underline{x}, n, t) = \frac{|e_{xx_c}(\underline{x}, n, t)|}{\bar{e}_c(n, t)} ; \quad \frac{x_2}{2} \leq n \leq \frac{x_2}{2} + (x_1 - s)$$

$$0 \leq t \leq t_f \quad (3.18)$$

The values  $\bar{T}_S$ ,  $\bar{T}_B$ , and  $\bar{w}$  could be made time dependent, but this does not seem necessary at the present time.

An acceptable design is one for which

$$\phi_i < 1.0 \quad i \in B \quad (3.19)$$

## B. Objective Function

The objective function for this study will be either minimum weight or minimum thickness. For minimum weight per unit surface area,

$$F(\underline{x}) = \rho_1 x_1 + \rho_2 x_2 + \rho_5 x_5 + W_{sup}/x_6 \quad (\text{thin sheet})$$

$$(3.20)$$

$$F(\underline{x}) = \rho_1 x_1 + \rho_2 x_2 + \rho_3 x_3 + \rho_4 x_4 + \rho_5 x_5 + W_{sup}/x_6 \quad (\text{sandwich})$$

where  $W_{sup}$  is the weight per unit length of panel perimeter of the support system that connects the shield structural layer to the primary structure of the vehicle. The size of these supports is chosen independently of this study on the basis of such things as minimum gage sizes, fabricating techniques, cost, etc.

If the objective function is minimum thickness then

$$F(\underline{x}) = x_1 + x_2 + x_5 \quad (\text{thin sheet}) \quad (3.21)$$

$$F(\underline{x}) = x_1 + x_2 + x_3 + x_4 + x_5 \quad (\text{sandwich})$$

Note that  $x_6$  does not enter explicitly. A value of  $x_6$  will be determined by the synthesis program which probably will be the minimum acceptable value of  $x_6$  as specified by a side constraint.

### C. Side Constraints

There will be certain cases when one or more of the design variables will tend to zero values or to unrealistically large values. Also, the analysis will be valid only in a certain subspace of the design space. All design points  $\underline{x}$  must be restricted to this subspace. Side constraints on the design variables are introduced to delimit that region of the design space which contains the realizable designs for which the analyses employed are valid. These side constraints may be, for example, minimum gage dimensions, fabrication constraints, max and min values of the design variables based on analysis limitations. A possible formulation of side constraints is

$$\phi_i = \max \left( \frac{x_{i-p}}{x_{i-p_{\max}}}, \frac{x_{i-p_{\min}}}{x_{i-p}} \right); \quad i \in S \quad (3.22)$$

where  $p$  is the number of elements of  $B$  and  $S$  is the set of side constraints on the design variables,  $\underline{x}$ .

Trade off studies are facilitated by incorporating into the algorithm one additional side constraint in the form of a total thickness limitation, TDMAX. This side constraint can be written as

$$\phi_j = TD/TDMAX \quad j \in S$$

where

$$TD = x_1 + x_2 + x_5$$

for the thin sheet substructure case, or

$$TD = x_1 + x_2 + x_3 + x_4 + x_5$$

for the sandwich substructure case. The index  $j$  represents a new element to be added to the set  $S$ .

The use of this side constraint on total thickness is explained in Chapter IV and in Appendix D. In cases when a strict minimum weight or minimum thickness optimization is undertaken, TDMAX is set at a value large enough to keep the constraint inactive.

#### D. Constraints in General

Each of the behavior functions and side constraints constrains the behavior of the system in a particular way. Because of the form of the optimization techniques to be used it is more convenient to formulate the constraints in the following way:

$$\begin{aligned} g_i(\underline{x}, z, t) &= 1.0 - \phi_i(\underline{x}, z, t) & z \in Z \\ i \in (B + S) \equiv C & & t \in T \end{aligned} \quad (3.23)$$

where  $Z$  is the closed set containing all cross-section points,  $T$  denotes the closed set of all times in the period of interest, and  $C$  is a set containing both the behavior constraint set and the side constraint set. Now, an acceptable design is one for which

$$\begin{aligned} 0 < g_i(\underline{x}, z, t) & & i \in C \\ & & z \in Z \\ & & t \in T \end{aligned} \quad (3.24)$$

#### E. The Fiacco-McCormick Function

The optimization problem for the system considered is one of inequality constrained optimization. An inequality constrained optimization problem can be reduced to a sequence of unconstrained optimization problems by the introduction of what is termed a penalty function. The Fiacco-McCormick<sup>5</sup> function,  $P(\underline{x}, r)$  is one such penalty function, and it is written explicitly as

$$P(\underline{x}, r) = F(\underline{x}) + r \sum_{i \in C} \frac{1}{g_i(\underline{x})} \quad (3.25)$$

where  $r$  is a parameter which approaches zero sequentially.

As is noticed, some of the  $g_i$ 's are functions of  $z$ , and  $t$ , the thickness coordinate and time, respectively, as well as  $\underline{x}$ . This is an undesirable situation because the  $\min g_i$  will occur at different  $z$ 's and at different times,  $t$ , when  $\underline{x}$  is changed. It is necessary that  $P = P(\underline{x}, r)$  only. The  $z$  and  $t$  variables could be eliminated by writing

$$P(\underline{x}, r) = F(\underline{x}) + r \sum_{i \in C} \frac{1}{\min_z \min_t g_i(\underline{x}, z, t)} \quad (3.26)$$

In this way, only the behavior at one time and one location, the worst case, is represented in the  $P(\underline{x}, r)$  function. Also, since gradients (finite difference) to this function are required, the values of  $z$  and  $t$  at which the  $\min_z \min_t g_i(\underline{x}, z, t)$  occur must be stored. Thus, if the values of  $z$  and  $t$  at which  $g_i(\underline{x}, z, t)$  attains its minimum values are denoted by  $(z_i, t_i)$ , the derivative of  $1/g_i(\underline{x}, z_i, t_i)$  with respect to the component of  $x_j$  of  $\underline{x}$  is given by

$$\frac{\partial}{\partial x_j} \left[ \frac{1}{g_i(\underline{x}, z_i, t_i)} \right] = - \frac{1}{g_i^2(\underline{x}, z_i, t_i)} \lim_{\Delta x_j \rightarrow 0} \left[ \frac{g_i(\underline{x} + \Delta x_j, z_i, t_i) - g_i(\underline{x}, z_i, t_i)}{\Delta x_j} \right]$$

Note that, in general, there will be as many sets  $(z_i, t_i)$  as there are constraints  $g_i$ , and that the necessity of performing analyses at specific times requires additional logic in the thermal analysis routine. Also, using this technique, there is no way to distinguish between designs that are very good except perhaps at one value of

(z,t) and designs which are poor for almost all values of (z,t) and yet unacceptable at only one (z,t) value.

A better way to eliminate (z,t) is by integration.<sup>6</sup> How this is done is demonstrated for the following cases using the thin sheet structural layer constraints. First, the z is integrated out of the  $g_i(\underline{x},z,t)$ 's which depend on z. Thus, for example,

$$\frac{1}{\bar{g}_4(\underline{x},t)} = \frac{1}{x_2} \int_{-\frac{x_2}{2}}^{+\frac{x_2}{2}} \frac{dz}{g_4(\underline{x},z,t)} \quad (3.27)$$

where multiplication by  $\frac{1}{x_2}$  maintains correct dimensions. Likewise,

$$\frac{1}{\bar{g}_5(x,t)} = \frac{1}{(x_1-s)} \int_{\frac{x_2}{2}}^{\frac{x_2}{2}+(x_1-s)} \frac{dz}{g_5(\underline{x},z,t)} \quad (3.28)$$

For  $g_6(\underline{x},z,t)$  and  $g_7(\underline{x},z,t)$ , things are somewhat different, because each is integrated over only part of the ablator thickness. Defining that part of the ablator which is in tension to have thickness ZT, and that part in compression to have thickness ZC, write

$$\frac{1}{\bar{g}_6(\underline{x},t)} = \frac{1}{ZT} \int_{ZT} \frac{dz}{g_6(\underline{x},z,t)} \quad (3.29)$$



$$\frac{1}{\bar{g}_7(\underline{x}, t)} = \frac{1}{ZC} \int_{ZC} \frac{dz}{g_7(\underline{x}, z, t)} \quad (3.30)$$

The remaining  $g_i$ 's are functions of  $\underline{x}$  and  $t$  only, or are constants. For notational consistency, define  $\bar{g}_i \equiv g_i$ , for  $i \in C_{XT}$ , where  $C_{XT}$  is the set of constraints which are functions of  $\underline{x}$  and  $t$  only.

For the sandwich structural layer case, a set of  $\bar{g}_i$ 's can be defined in a manner exactly analogous to that described above for the thin sheet case. The function  $P(\underline{x}, r)$  can be written as

$$P(\underline{x}, r) = \frac{1}{t_f} \int_0^{t_f} dP(\underline{x}, r, t) = \frac{1}{t_f} \left\{ F(\underline{x}) \int_0^{t_f} dt + r \sum_{i \in C} \int_0^{t_f} \frac{dt}{\bar{g}_i} \right\}$$

or

$$P(\underline{x}, r) = F(\underline{x}) + r \left\{ \frac{1}{t_f} \left[ \sum_{i \in B} \int_0^{t_f} \frac{dt}{\bar{g}_i(\underline{x}, t)} \right] + \sum_{i \in S} \frac{1}{\bar{g}_i(\underline{x})} \right\} \quad (3.31)$$

behavior side  
constraints constraints

The function  $P(\underline{x}, r)$  is minimized for each member of a strictly monotone decreasing sequence of  $r$  values,  $\{r_k\}$ .

#### F. The Fletcher-Powell Method

Methods of unconstrained minimization can now be applied to the function  $P(\underline{x}, r)$  with one important thing kept in mind; that it is possible to choose or to arrive at a point  $\underline{x}$  in the design space that is unacceptable, i.e., such that one or more constraints are violated. Note that, except in the case of side constraints, the  $\bar{g}_i$ 's of (3.31)

and (3.27),(3.28),(3.29),(3.30) can not satisfactorily accomodate a constraint violation. Behavior constraint violation is handled by storing the minimum value of each of the  $g_i$ 's as

$$\begin{aligned}
 f_1(\underline{x}) &= \min_t g_1(\underline{x},t) \\
 f_2(\underline{x}) &= \min_t g_2(\underline{x},t) \\
 f_3(\underline{x}) &= \min_t g_3(\underline{x},t) \\
 f_4(\underline{x}) &= \min_z \min_t g_4(\underline{x},z,t)
 \end{aligned} \tag{3.32}$$

and in general

$$f_i(\underline{x}) = \min_z \min_t g_i(\underline{x},z,t)$$

If at any time during an analysis

$$f_i(\underline{x}) \leq 0.0 \quad i \in C \tag{3.33}$$

then

$$P(\underline{x},r) = \infty \tag{3.34}$$

and the analysis is terminated at this time.

Hence,  $P(\underline{x},r)$  is generalized to:

$$P(\underline{x},r) = \left\{ \begin{array}{l} F(\underline{x}) + r \left\{ \frac{1}{t_f} \left[ \sum_{i \in B} \int_0^{t_f} \frac{dt}{\bar{g}_i(\underline{x},t)} \right] + \sum_{i \in S} \frac{1}{\bar{g}_i(\underline{x})} \right\}; \quad f_i(\underline{x}) > 0.0 \\ \infty \quad ; \quad f_i(\underline{x}) \leq 0.0 \end{array} \right. \tag{3.35}$$

With this generalization of the  $P(\underline{x}, r)$  function, the Fletcher-Powell method can be applied directly.

The Fletcher-Powell method<sup>4</sup> is a second order gradient method. It is considered to be the most powerful general procedure now known for finding the local minimum of a general function.<sup>13</sup> It is designed so that, when applied to a quadratic function in  $n$  independent variables it locates the minimum in  $n$  iterations. Starting from any positive definite matrix  $H_0$ , each iteration consists of the following operations. Let the current design point be  $\underline{x}_i$  and the gradient at  $\underline{x}_i$  be given by  $\underline{g}_i = \nabla P(\underline{x}, r)$ . Then the current direction of travel is:

$$\underline{s}_i = - H_i \underline{g}_i$$

Choose  $\alpha_i = \alpha_i^*$  by minimizing  $P(\underline{x}_i + \alpha_i \underline{s}_i, r)$ . This is a one dimensional minimization along the line  $\underline{x}_i + \alpha_i \underline{s}_i$ .

Set 
$$\underline{\sigma}_i = \alpha_i^* \underline{s}_i$$

$$\underline{x}_{i+1} = \underline{x}_i + \underline{\sigma}_i$$

$$H_{i+1} = H_i + A_i + B_i$$

where

$$A_i = \frac{\underline{\sigma}_i \underline{\sigma}_i^T}{\underline{\sigma}_i^T \underline{y}_i}$$

$$B_i = - \frac{H_i \underline{y}_i^T \underline{y}_i H_i}{\underline{y}_i^T H_i \underline{y}_i}$$

$$\underline{y}_i = \underline{g}_{i+1} - \underline{g}_i$$

The algorithm is applied to  $P(\underline{x}, r)$  and optima are obtained for successively smaller values of  $r$  until the optimum of  $P(\underline{x}, r)$  is "sufficiently" close to that of  $F(x)$ .

For each value of  $r$ , convergence is reached when the quantity  $\frac{1}{2} \underline{g}_i^T H_i \underline{g}_i$  attains a value less than some prescribed amount. If  $P(\underline{x}, r)$  is quadratic in  $\underline{x}$ ,  $\frac{1}{2} \underline{g}_i^T H_i \underline{g}_i$  is a measure of the amount by which the current value of  $P(\underline{x}, r)$  exceeds the minimum value,  $P_{\min}$ . Since  $P(\underline{x}, r)$  is in general not quadratic,  $\frac{1}{2} \underline{g}_i^T H_i \underline{g}_i$  will be useful mainly in the neighborhood of the minimum point. As the value of  $r \rightarrow 0$ ,  $P(\underline{x}, r) \rightarrow F(\underline{x})$  and the local minimum of  $P(\underline{x}, r)$  tends to the local minimum of  $F(\underline{x})$ , provided it is assumed that  $r \rightarrow 0$  faster than

$$\frac{1}{t_f} \int_0^{t_f} \frac{dt}{\bar{g}_i(\underline{x}, t)} \rightarrow \infty ; \quad i \in B$$

and faster than

$$\bar{g}_i \rightarrow 0 ; \quad i \in S .$$

Since the strictly monotonic sequence of values of  $r$ ,  $\{r_k\}$ , is arbitrary, such a sequence can always be found which will satisfy the above conditions. Fiacco and McCormick<sup>14</sup> prove this under the restriction that  $P(\underline{x}, r)$  is strictly convex over the acceptable region for  $r > 0$ . Strict convexity guarantees that the minimum obtained is the global minimum. The proof goes through with a modified convexity assumption which assumes that local convexity exists. The minimum thus obtained is strictly speaking only a local

minimum. Confidence that a particular local minimum is in reality a global minimum can be obtained by using several different initial points in successive optimizations. If the same minimum point is obtained each time, it is probably a global minimum point.

#### G. Analysis-Synthesis Implementation

The analysis, which is described in Chapter II and in Appendices A, B, and C, is necessary to determine the value of  $P(\underline{x}, r)$  of eq. (3.35) when  $\underline{x}$  and  $r$  are known. In the course of the synthesis, the function  $P(\underline{x}, r)$  must be evaluated many times. In theory, each evaluation of  $P(\underline{x}, r)$  requires a complete analysis (i.e., the determination of thermal profiles, deflections, stresses, and strains throughout the panel at every instant of time during the reentry trajectory). In practice, however, there are many instances when the function  $P(\underline{x}, r)$  can be evaluated either exactly or with reasonable accuracy through the use of an abbreviated (partial) analysis. The following paragraphs explain the situation in detail.

A complete analysis is naturally separated into two parts, (1) the thermal analysis (determination of thermal profiles and surface recession rates) and (2) the structural analysis (determination of stresses and deflections). Computer time required for a thermal analysis is six times that required for a structural analysis (30 seconds vs. 5 seconds). Thus, since most of the time associated with a complete analysis is required for the thermal analysis, significant time savings will be obtained when the thermal analysis can be avoided.

Each time a new design point of increased optimality is successfully occupied, the recession rates and thermal profiles, from the thermal section of the complete analysis which is performed at this point, are stored in a large array (TSTOR). Then, under certain conditions, subsequent adjacent design points are analyzed using the stored thermal data as an input to the structural analysis. Such an "abbreviated" analysis yields an approximate response (sometimes exact) in one sixth the time required for a "complete" analysis. Care must be taken, however, to insure that an acceptable design point attained on the basis of abbreviated analyses is not in fact unacceptable when a complete analysis is undertaken at the same point.

The conditions under which abbreviated analyses have been used successfully are as follows:

1. Computation of the gradient to  $P(\underline{x}, r)$

a. When  $\underline{\Delta x} = \Delta x_1 \tau_1$  ( $\tau_i$  is a unit vector in  $i^{\text{th}}$  coordinate direction),

if  $x_1 > 0.22^\circ$

b. When  $\underline{\Delta x} = \Delta x_2 \tau_2$ , if  $x_1 > 0.17^\circ$

c. When  $\underline{\Delta x} = \Delta x_3 \tau_3$ , if  $|T_m - T_{m+1}| < 200^\circ R$

d. When  $\underline{\Delta x} = \Delta x_4 \tau_4$ , if  $x_1 > 0.14^\circ$

e. When  $\underline{\Delta x} = x_5 \tau_5$ , if  $|T_m - T_n| < 100^\circ R$ ; thin

$|T_{m+1} - T_n| < 100^\circ R$ ; sand

f. When  $\underline{\Delta x} = x_6 \tau_6$ , always. Use of an abbreviated analysis here yields exact results because the

thermal analysis is independent of the planform dimension.

2. One dimensional search ( $\underline{s}$  is the current search direction,  $\underline{x}$  is the occupied design point,  $\underline{x}'$  is the tentative new design point).

a. If  $x_1 > 0.22$  and  $|x_1' - x_1| < 0.1$

b. If  $\left| \frac{x_1' - x_1}{x_1} \right| < 0.01$

c. If  $s_1 < 0.3$

With the exception of condition (1.f), the above conditions are strictly empirical and are justified only by the fact that they reduce computer time significantly with no loss in the accuracy of the final result.

## CHAPTER IV

### RESULTS

#### A. General

This chapter details the results which have been obtained by applying the computer programs to several specific cases. Twelve (12) cases are documented in the following pages. Five (5) cases have a thin sheet substructure, and the remaining seven (7) have a sandwich substructure. Tables 4.1 and 4.2 contain summaries of the information associated with the twelve test cases. Table 4.3 summarizes the complete design path of case S3. The remaining tables contain information on trajectories, materials, and test case response at the initial and final design points for all cases except case S3. For this case the entire design path is documented (Tables 4.3 and 4.23).

The test case results shed some light on the following matters:

1. The presence of relative minima in the design space.
2. Which is the better structural layer material, aluminum or fiberglass?
3. The best design is not always the one which has the structural layer operating at its maximum permitted temperature.
4. Whether or not a sandwich substrate is always superior to a thin sheet.



5. The difference between minimum weight and minimum thickness designs.
6. Whether or not anything is gained by allowing the sandwich substrate to have different face thicknesses.
7. Some additional comments on the design of heat shield panels.
8. Operational characteristics of the synthesis technique:  
How to choose  $r$  and  $c$  ( $r_{i+1} = r_i/c$ ), the Fiacco-McCormick Function parameters; some pitfalls of the synthesis technique.

## B. Trajectories

Two trajectories were used for the design test cases:

### 1. Trajectory I

This is a ballistic reentry trajectory. It is taken from Swann<sup>15</sup>. The vehicle location considered is the stagnation point. Table 4.4 contains trajectory information over the time period of interest which is 900 sec. (Table D.1 of Appendix D can be referred to for an explanation of the headings in Table 4.4). The maximum cold wall convective heating rate is 500 Btu/ft<sup>2</sup> sec. at 100 sec.. The wall pressure ( $p_w$ ) is computed from equation (A.4). Its maximum value is approximately 1700 lbs/ft<sup>2</sup> at 850 sec.

### 2. Trajectory II

This is a trajectory typical of lifting reentry. It is taken from Newell<sup>16</sup>. The vehicle location considered is the stagnation point. Table 4.5 contains trajectory information over the time

period of interest, which is 2400 sec. The maximum cold wall convective heating rate is 80 Btu/ft<sup>2</sup>-sec. at 1375 sec. The wall pressure is entered as input data in the last column of Table 4.5. Its maximum value is 110 lbs/ft<sup>2</sup> at 125 sec.

### C. Materials

The ablator material properties are taken from Wilson<sup>17</sup>; the aluminum properties are from MIL-HNBK-5<sup>18</sup> and MIL-HNBK-23<sup>19</sup>; the fiberglass properties are from Boller<sup>20</sup>, Laporte<sup>21</sup> and MIL-HNBK-17<sup>22</sup>; the insulator properties can be found in Laporte<sup>23</sup>.

The non-temperature dependent properties are tabulated in Tables 4.6, 4.7, 4.8 and 4.9. Table 4.6 corresponds to a LDPN ablator, thin sheet aluminum structural layer, and microquartz insulation. Table 4.7 corresponds to the case of a LDPN ablator, thin fiberglass structural layer, and microquartz insulation. Table 4.8 supplies information associated with the case of LDPN ablator, aluminum sandwich structural layer and microquartz insulation. Table 4.9 corresponds to LDPN ablator, fiberglass sandwich, and microquartz insulation.

The temperature dependent mechanical and thermal properties for the LDPN ablator are tabulated in Table 4.10. Tables 4.11 and 4.12 contain the temperature dependent properties for thin sheet structural layers composed of aluminum and fiberglass, respectively, and Tables 4.13 and 4.14 contain the temperature dependent properties for the aluminum and fiberglass sandwich structural layers, respectively. Finally, the microquartz and wall enthalpy values

are to be found in Table 4.15.

#### D. Documentation of the Various Test Cases.

Tables 4.1 and 4.2 collect together in a convenient form data concerning the final design points, run times and % design improvement. Table 4.3 contains a summary of the information which is generated in the course of an optimization study. It shows the design path from the initial design point to the final design point.

A behavior constraint on a design is considered active if it has its value of  $f_j$  equal to or less than 0.10. This means that the design is within 10% of failure. In Tables 4.1 and 4.3, an active behavior constraint is denoted by (\*). A behavior constraint is considered almost active if it has an  $f_j$  value of 0.20 or less. An almost active constraint is indicated by (+). A design variable side constraint becomes active if the design variable approaches to within 10% of it. An active side constraint is denoted by (\*\*).

Tables 4.16 through 4.27 contain data on both initial and final design points, and on the actual behavior function values at these points. Table 4.23 contains a complete design path (summarized in Table 4.3). Tables 4.16 through 4.27 are explained in the following paragraphs.

##### 1. Thin sheet structural layer cases.

These cases are recognized by the prefix "T" in the case designation. Five thin cases are presented. The layer materials used and the trajectory considered for any particular case can be

determined by consulting Table 4.1. Cases will henceforth be referred to by case designation, i.e. T1, T2, S3, etc., alone. Complete information regarding the initial and final design points of cases T1 through T5 is contained in Tables 4.16 through 4.20. For example Table 4.17 corresponds to Case T2. Referring to Table 4.17, R is the current value of r for the Fiacco McCormick function  $P(\underline{x}, r)$ , T is an estimate of the distance which must be traveled from the design point currently occupied to the point associated with the optimum weight (or thickness). The design point occupied is shown under "X", and it is bracketed by the side constraints XMIN and XMAX. Under "BEHAVIOR CONSTRAINT INFORMATION", "CRITICAL VALUE" is the value of the behavior function most closely approximating the maximum permitted; or "LIMITING" value. The time during the trajectory at which the "CRITICAL" value is reached is given under "TIME AT CRITICAL VALUE", and "NORMALIZED VALUE" gives  $f_i(\underline{x})$ , where  $f_i(\underline{x}) = \min_z \min_t [1.0 - \phi_i(\underline{x}, z, t)]$ . See the text of Chapter III associated with equation 3.1 for further explanation. It will be noticed that two numbers are contained in the column entitled "CRITICAL VALUE" in the case of constraints 4 and 5. (see Table 4.17). The top number gives  $\sigma_{xx}$ , and the bottom one gives  $\sigma_{yy}$ . Two numbers appear in the column labeled "LIMITING VALUE" opposite constraint no. 5, the ablator stress condition. The upper number gives the yield stress under uniaxial tension, the bottom one gives the yield stress in uniaxial compression. Also, a minus sign signifies compressive stress when

associated with constraints 4 and 5. The sign associated with constraint number 3 indicates the direction of the transverse displacement. A minus sign means that the panel deflects inward at its center (in the negative z direction. See Figure 2.5).

## 2. Sandwich structural layer cases.

Complete information regarding the response at the initial and final points for these cases (S1 through S7) is contained in Tables 4.21 through 4.27. The comments of the previous paragraph dealing with sign conventions, headings and so forth, apply also for the sandwich cases.

A complete design path is documented for case S3. This is contained in Table 4.23, and is summarized in Table 4.3.

## E. Discussion

The discussion will treat the matters set forth in section A of this chapter.

1. The presence of relative minima in the design space is demonstrated by cases T3 and T4. Although there is not a great deal of difference between the weights obtained ( $9.97 \text{ lbs/ft}^2$  vs.  $9.78 \text{ lbs/ft}^2$ . See Table 4.1), the final design points attained are very different. In fact, they correspond to two different structural design concepts. Case T3 results in a design which permits the structure to operate near its maximum permissible temperature. Ablator strength is not effectively utilized; that is, it is not available to resist bending near the end of the trajectory (Traj. I) where the dynamic pressure reaches a peak value. Case T4 yields a design which utilizes the ablator strength. The structural layer

reaches a temperature of only 144°F.

Another example of relative minima is offered by cases S1 and S3 (see Table 4.1). Case S1 allows a hot structure (top face), both are constrained by back wall temperature and by deflection, and the minimum weights differ by about 1.4%. Yet the sandwich of case S3 has a core thickness which is 67% greater than that of case S1, and the sandwich face thickness of case S3 is 18% thinner than that of case S1. Thus, core thickness and face thicknesses have been traded off, but the resulting designs exhibit essentially the same behavior.

A third example of relative minima is given by the comparison of case S6 with either case S1 or case S3. The comparison with S1 will be discussed.

Cases S1 and S6 are both critical in back wall temperature. But while S1 is deflection critical, S6 is almost critical in yield stress in the top sandwich face ( $f_5$ ). See Table 4.1. Case S6 has a tremendously deep sandwich core. This causes a very rigid structure (note the center deflection) which prevents the relief, through bending, of the top sandwich face stress.

The optimization routine as developed is, strictly speaking, an algorithm for design improvement. This is as strong a declaration as one can make about the method unless the function  $P(\underline{x}, r)$  can be proven to be convex over the region of the design space of interest. Since this can not be done for the present problem, confidence that the improved design obtained is in fact the global

optimum can be gained by "double pointing". In essence "double pointing" means to restart the program at an initial point some distance away from the previous initial point and then to compare the new final point with the previously obtained final point. If they are essentially the same, the final design point is said to have been "double pointed". Of course, this procedure can be repeated for as many new initial design points as the designer can generate. A "double pointed" or "triple pointed" final design point has not been proven thereby to be the global optimum, but this information, coupled with the designer's knowledge of the design space, results in a high degree of confidence being placed in the assertion that, in fact, it is.

2. Which is the better substrate material, aluminum or fiberglass?

On the basis of minimum weight, aluminum and fiberglass result in thin sheet substructure designs in which aluminum has a slight weight advantage (Cases T1 and T4, Table 4.1). On the basis of minimum weight, aluminum results in a sandwich substructure panel which is slightly lighter than the result obtained with fiberglass. Compare cases S1 and S3 with S7 (Table 4.1).

The response at the final design points of cases T1 and T4 is essentially similar, the fiberglass thin sheet (T1) being slightly more critical in structural layer stress and in ablator stress ( $f_4$  and  $f_5$  in Table 4.1) than the aluminum thin sheet case. It should be noted that these cases (T1 and T4) effectively utilize ablator

strength to resist bending. If ablator strength is not reliable and must be discarded, it is likely that a definite weight advantage in favor of fiberglass would develop, because fiberglass retains its strength and stiffness at high temperatures to a greater degree than does aluminum. Compare, in Tables 4.11 and 4.12, Young's Modulus and yield strength for aluminum and fiberglass, respectively.

Two differences can be seen in the response of cases S1 and S3 compared with that of case S7. First, the sandwich face stresses are much more critical in case S7 than in cases S1 and S3. Second, the ablator stress of cases S1 and S3 is much higher than that in case S7.

The differences in response noted above must be considered if weight differences among the several test cases are marginal.

The emergence of aluminum as the better sandwich substrate material is interesting because the high temperature properties of aluminum are inferior to those of fiberglass (See Tables 4.13 and 4.14). The reason for the resulting weight superiority of aluminum is apparent when one observes that the top sandwich face temperatures of cases S3 and S7 reach only 1000°R (540°F) rather than the maximum value of 1200°R (740°F) permitted in each case (See Table 4.23 for case S3 and Table 4.27 for case S7). At 1000°R aluminum is still clearly superior to fiberglass, because it has a Young's modulus almost three times that of fiberglass and a yield strength 28% greater than that of fiberglass (Tables 4.13 and 4.14). At higher temperatures fiberglass becomes superior. With respect



to case S1, note that, the maximum top face temperature of 1200°R is more closely approached than in case S3, the actual temperature reached being 1109°R, and that case S1 is slightly heavier than its counterpart, case S3.

The results of cases S1, S3, and S7 very clearly point out that an optimum design will not always be structural layer temperature constrained, and thus they illustrate the fallacy of assuming in advance that the most efficient system is one in which the structural layer operates at as high a temperature as possible.

According to recent reports,<sup>24</sup> adhesives are available<sup>5</sup> which can sustain temperatures of approximately 1210°R (750°F) without failure. This temperature of 1210°R would then constitute the maximum temperature permissible in the top sandwich face (or at any other interface between layers where the adhesive is used).

Current heat shield design practice appears<sup>25,26</sup> to be such that the ablator-top sandwich face interface temperature is assumed in advance to be equal to the value that the adhesive is able to sustain, about 1210°R. As noted above, the results of cases S1, S3, and S7 demonstrate that this should not be done. It is true that the assumption of maximum top face temperature will result in a minimum ablator thickness, but because the properties of the structural substrate have degraded, a heavier structure is needed. This trade off can be observed between cases S1 and S3, particularly in the sandwich face thicknesses of the final designs (Table 4.1). Also, this maximum temperature assumption could, from the outset,

eliminate from consideration a structural material which will ultimately yield a better design, inspite of the fact that its high temperature properties are not spectacular.

3. The best design is not always the one which has the structural layer operating at its maximum permitted value.

The validity of this statement was established and discussed in the previous section.

4. The question of whether or not a sandwich substrate is always superior to a thin sheet substrate can be answered in the light of the results of cases T1, T2, T5, S1, S4, and S5. If weight is of primary importance, the sandwich is clearly superior to the thin sheet. This can be seen by comparing case T1 with case S1, and by comparing case T5 with S5. However, if thickness is of primary importance, then the thin sheet is better than the sandwich sheet. This is clear by comparison of Case T2 with case S4.

As is noted on page 32 of Chapter III, the planform dimension for both of these cases approaches the lower side constraint value (0.5' for all cases considered).

The advantage, based on total system thickness, of the thin sheet over the sandwich sheet is lessened somewhat by the observation that the thin sheet case T2 is deflection critical while the sandwich case S4 is not. This means that the span of Case S4 could be considerably lengthened, say to about 1.5 ft, before the structure would become deflection critical. The thin case T2 is restricted to the 0.69' span attained by the optimization program. Also, case

T2 utilizes the ablator strength to sustain the maximum pressure loading, while case S4 does not. If one objects to this utilization of ablator strength, based on, possibly, reliability considerations, then Case T2 would require a much thicker aluminum sheet (about 1/4" thick), and, consequently, would be much heavier than the present case T2.

In conclusion, it can be stated that, if system thickness is the overriding consideration, if span length is of secondary importance, and if the ablator material can be judged to be a reliable structural material, then it is possible that a panel utilizing a thin sheet structural layer could be superior to a panel with a sandwich sheet substructure.

5. Because of the thermal problem, the total system thickness has a lower bound which exercises a control over the final design whether the objective function,  $F(\underline{x})$ , is weight or thickness. What occurs in response to the two different objectives is a trading off of the various layer thicknesses. Thus, for example when minimum weight is the objective the layers composed of heavier materials tend to get very thin, while when minimum thickness is the objective this does not happen. Compare cases T1 and T2, S3 and S4. Thin case weight difference between minimum weight and minimum thickness designs was found to be nominal. See cases T1 and T2. In the case of a sandwich substructure there is a difference of 25% in the weights attained in cases S3 and S4. This raises the possibility of performing studies on trade off of weight and thickness on sandwich structure

cases. These studies would best be made by fixing the span at the value attained in the minimum weight design. This would be  $x_6 = 1.262'$  for case S3. (Program control integer "FIX" being set at 1 would automatically handle this. See Appendix D). Then the total system thickness, TDMAX, is set at a value less than the system thickness associated with the minimum weight design, and another minimum weight design path is generated, resulting in a weight which should be greater than that previously attained because of the side constraint on total thickness (See Chapter III, section C). If the side constraint on total thickness is not active and/or a weight is attained which is less than that previously attained, then the problem of relative minima has again reared its head. Granting that no abnormalities, such as those posed, develop, a sequence of designs will be obtained, each succeeding one being of greater weight and lesser thickness, until the absolute minimum thickness design is obtained. By "absolute minimum thickness design" is meant one such as that of case S4 where thickness is the objective. Likewise case S3 could be referred to as an "absolute minimum weight" design. Since relative minima are present, this terminology must be understood to apply only to a certain subspace of the design space which does not exhibit relative minima. When the complete set of designs is available, a curve of minimum weight vs. allowable thickness can be constructed and trade-off studies can be made from it. The end points of the curve would consist of cases similar to S3 and S4.

6. Can a meaningful gain in structural efficiency be obtained by allowing the sandwich substructure to have different face thicknesses?

The computer program is set up in such a way that the sandwich faces can be of different thicknesses (See Appendix D for details). The materials of which the faces are comprised can be different also.

A test case was undertaken in order to determine the answer to the above question. This is case S2 (see Tables 4.1 and 4.22). It can be compared to case S1 (Tables 4.1 and 4.21). The resulting preliminary answer to the question above must be no. It would be interesting to see if different materials as well as thicknesses would change this answer.

7. Some additional comments on the design of heat shield panels.

One of the serious problems of heat shield design is the incompatibility of the expansion coefficients of the ablator materials and the structural substrate. The problem is most serious during the cold soak condition which exists up to the instant at which reentry begins. The cure temperature of the composite panel with LDPN ablator is 350°F (810°R). The expansion coefficient (in/in°F) for LDPN is  $20 \times 10^{-6}$  while that of aluminum is  $12 \times 10^{-6}$  and that of fiberglass is  $5 \times 10^{-6}$ . When the temperature drops from cure temperature (350°F) to cold soak temperature (-100°F), a tremendous tensile stress is induced in the ablator because it contracts much more than the substructure does. The panel is almost always

critical in ablator stress and this fact has led some investigators<sup>2</sup> to abandon phenolic nylon in favor of elastomeric silicon. Elastomeric silicon is heavier than LDPN (41 lbs/ft<sup>2</sup> vs. 36 lbs/ft<sup>2</sup>), has little mechanical stiffness and strength, but it has a higher ultimate strain capacity at cold soak temperatures. Thus although it can not be utilized very effectively as a structural material, elastomeric silicon eliminates the cold soak failure problem.

It has been noted<sup>27</sup> that the ablator cold soak problem can be solved by placing a flexible rubber bond between ablator and substructure. This will limit the interface temperature to 300°F (760°R) which, based on the results already obtained concerning the desirability of attaining the highest possible interface temperature, will not necessarily result in a heavier panel.

Another technique which might be applied to the cold soak incompatibility problem, and to the material incompatibility problem in general, is that of applying a prestress to the structural substrate. Since in the present case, the ablator on the whole shrinks faster than the substrate in cooling down from the cure temperature, the substrate would be prestressed in tension at the cure temperature of 350°F, and as the panel is cooled, the tension would be released so that at room temperature (or some other convenient temperature) there would be no residual stress in either the ablator or the substrate. This technique would be particularly applicable to flat panels.

The soak soak condition used in the test cases studied is the room temperature condition of 540°R (Notice, in Tables 4.6, 4.7, 4.8,

and 4.9, the array TINT, which is the initial temperature distribution array). This temperature was used because it was felt that combining a cure temperature of 810°R with a cold soak temperature of 360°R would result in unrealistically high ablator and structural layer stresses. Unrealistic because at 810°R the LDPN ablator is in an almost plastic state and so there will very likely be some flow and accompanying stress relief on cool down. Unrealistic, also, because while the panel remains at room temperature for the length of time between completion of the cure and its deployment in a vehicle, further stress relief will occur due to creep in the ablator. For these reasons a more realistic base temperature for the stress analysis would perhaps be in the 150-250°F (610-710°R) range. Because of lack of data on the creep behavior of the ablator material, and on probable stress relief on cool down from cure temperature, and for the reason stated above, the room temperature (540°R) initial temperature distribution was used.

#### 8. Operational characteristics of the synthesis program.

Proper choice of the initial value of  $r$ , and subsequent to this choice, the choice of the parameter  $c$ , which specifies how much  $r$  is reduced between cycles (i.e.,  $r_{i+1} = r_i/c$ ), is very critical to the successful operation of the optimization algorithm. Some discussion of these subjects is contained in a paper by Fiacco and McCormick<sup>5</sup>. They reach the conclusion that "the overall computational effort is relatively insensitive to the rate of reduction of  $r$ ". Also they give two analytical methods for determining the initial  $r$  value,  $r_1$ . One of these requires the first derivatives of  $P(\underline{x}, r)$  at

$\underline{x}^0$ , the initial point, and the other requires the second derivatives of  $P(\underline{x}, r)$  at  $\underline{x}^0$ . Since approximate derivatives must be resorted to in the present case, these methods are inconvenient.

Experimentation with the computer programs for the present problem has resulted in the development of a set of empirical rules for the selection of  $r_1$  and  $c$  which appear to work quite well. First, if the designer has no well conceived idea of a good balanced design for the system (in terms, of course, of layer thicknesses and plan-form dimensions, assuming the materials and trajectory are pre-assigned), a large initial value of  $r$  is necessary, say  $r = 1 \times 10^4$  or  $r = 1 \times 10^6$ . A large initial value of  $r$  will tend to move the design point away from all the constraints, thus when  $r$  is subsequently reduced the design space point will tend to "funnel" down to the optimum design point remaining away from the constraints until this point is attained.

The large initial value of  $r$  used when the initial design point is a poor approximation to the optimum design point will usually result in an increase in the objective function  $F(\underline{x})$  on the completion of the first cycle (when convergence has been obtained for  $r_1$ ). This can be observed, in the documented complete design path for case S3, in Table 4.3 or Table 4.23. Note that  $F(\underline{x})$ , which is weight for this case, increases during the first two cycles, i.e., for  $r_1 = 1 \times 10^4$  and  $r_2 = 1 \times 10^2$ . This indicates that a better choice for  $r_1$  would probably have been  $r_1 = 1 \times 10^2$  rather than  $1 \times 10^4$ . Table 4.2 shows that various values have been chosen in the various



test cases. Most of the earlier test runs made used  $r_1 = 1 \times 10^6$ , but comparing these results with those of later runs, which usually used  $r_1 = 1 \times 10^4$ , indicates that  $r_1 = 1 \times 10^4$  is large enough. (The cases tabulated in Table 4.2 appear there more or less in the order in which the runs were made.)

Just as it is possible to choose a value  $r_1$  which is too large, it is possible to choose one which is too small. However, while too large a value of  $r_1$  will usually result only in excessive run time, too small a value can lead to a final design point which is non-optimum. That is, when  $r$  is reduced too quickly, or when the initial  $r$  value is too small, the design point may encounter one of the behavior constraints too soon with the result that further moves are impossible and the design point is "trapped". Theoretically this should not occur, and the explanation for why it does lies in the nature of the function  $P(\underline{x}, r)$ . Thus, as  $r$  becomes very small,  $P(\underline{x}, r)$ , which equals  $F(\underline{x}) + r \sum G_i(\underline{x})$  where  $G_i(\underline{x})$  denotes the integrated constraints, becomes equal to  $F(\underline{x})$  alone, since it is postulated that  $r \rightarrow 0$  faster than  $G_i(\underline{x}) \rightarrow \infty$ . Thus, as a behavior constraint ( $f_i = 0$ ) is approached,  $P(\underline{x}, r)$  has the value  $F(\underline{x})$  right up to within an infinitesimal distance  $\epsilon$  from the constraint, but at the constraint  $P(\underline{x}, r)$  has the value  $\infty$  ( $1 \times 10^{30}$  in the computer program).

It should be noted that the set of functions,  $\{P_i(\underline{x}, r_i)\}$ , for each  $r_i$ , can be thought of as a sequence of continuous functions which are non uniformly convergent<sup>28</sup> on the closed set of points which is the acceptable region of the design space plus the constraint

boundaries. There is no continuous function,  $U(\underline{x})$ , say, to which the sequence  $\{P_i(\underline{x}, r_i)\}$  converges on this set, as  $i \rightarrow \infty$  ( $r_i \rightarrow 0$ ). As long as  $r_i$  is not small  $P_i(\underline{x}, r_i)$  is a reasonably well behaved continuous function. As  $r_i$  gets smaller the function is still continuous but less well behaved. When  $r = 0$  the function is discontinuous, having a jump of  $\infty$  in an infinitesimal distance at the boundary of the set. This discontinuity, or, at least, the near discontinuity for  $r$  small but not zero causes the Fletcher-Powell technique to perform poorly and results in the aforementioned "trapped" design point.

It is possible that case S6, which has been discussed as an example of relative minima, represents a "trapped point" since it is very critical only with respect to back wall temperature. From Table 4.2 it can be seen that case S6 starts with a fairly low value of  $r$  even though the initial design point is poor (initial weight = 18.08 lbs/ft<sup>2</sup>).

The question of whether or not lower initial values of  $r$  may be used in conjunction with smaller  $c$  values arises. Experience with the test cases documented and others not documented indicates that this will not improve running efficiency. It is possible that a smaller  $c$  value would lessen the occurrence of "trapped points". A  $c$  value of 100, which is fairly large, has proved satisfactory in most of the cases studied. Smaller  $c$  values do not affect enough of a change in the  $P(\underline{x}, r)$  function to get significant changes in  $F(\underline{x})$  from one value of  $r$  to the next.

The integrated nature of the constraints is responsible for the large  $c$  value used. Integrating the constraints tends to smooth the surface represented by  $P(\underline{x}, r)$  and this smoothness is effectively counteracted by changing  $r$  drastically between each cycle.

Case	T1	T2	T3	T4	T5	S1	
Str. Type	Thin	Thin	Thin	Thin	Thin	Sandwich	
Matis.	Abl.	LDPN	LDPN	LDPN	LDPN	LDPN	
	Str.	FG	FG	Ae	Ae	FG	
	Ins.	MO	MO	MO	MO	MO	
Trai.	No.	I	I	I	I	II	
	Type	Ballistic	Ballistic	Ballistic	Ballistic	Lifting	
	Dur.	900	900	900	900	2400	
Obj. func.	weight	thickness	weight	weight	weight	weight	
sys. wgt.	9.82	10.21	9.97	9.78	10.93	8.68	
sys. thk.	.245	.221	.266	.288	.374	.267	
Final Design Point	x <sub>1</sub>	.1977	.1913	.1655	.2106	.2155	.1669
	x <sub>2</sub>	.0059	.0163	.0099	.0015	.0115	.0053
	x <sub>3</sub>	-----	-----	-----	-----	-----	.0314**
	x <sub>4</sub>	-----	-----	-----	-----	-----	.0053
	x <sub>5</sub>	.0413	.0137	.0895	.0756	.1472	.0608
	x <sub>6</sub>	.5542**	.6950	.5661	.6736	.9800	1.0636
Crit. behav. func. val/ crit. time	f <sub>1</sub>	.467/900	.463/900	.178/900+	.497/900	.004/2400*	.076/900*
	f <sub>2</sub>	.124/900+	.040/900*	.137/900+	.175/900+	.116/2400+	.045/900*
	f <sub>3</sub>	.198/851+	.003/851*	.038/851*	.174/900+	.312/1127	.045/845*
	f <sub>4</sub>	.483/1	.490/851	.263/851	.535/1	.728/1	.336/356
	f <sub>5</sub>	.360/485	.265/494	.579/349	.682/588	.322/1092	.737/1
	f <sub>6</sub>	.588/125	.585/5	.685/349	.703/140	.586/1	.985/845
	f <sub>7</sub>	.892/851	.924/851	.935/851	.910/849	.937/1	.667/845
	f <sub>8</sub>	-----	-----	-----	-----	-----	.617/356
	f <sub>9</sub>	-----	-----	-----	-----	-----	.936/16

TABLE 4.1 Summary of Cases treated

\* active behavior constraint; + nearly active constraint; \*\* active side constraint

Case	S2	S3	S4	S5	S6	S7	
Str. type	Sandwich	Sandwich	Sandwich	Sandwich	Sandwich	Sandwich	
Matls.	Ab1.	LDPN	LDPN	LDPN	LDPN	LDPN	
	Str.	FG	FG	FG	FG	A2	
	Ins.	MO	MO	MO	MO	MO	
Traj.	No.	I	I	I	II	I	
	Type	Ballistic	Ballistic	Ballistic	Lifting	Ballistic	
	Dur.	900	900	900	2400	900	
Obj. Func.	Weight	Weight	Thickness	Weight	Weight	Weight	
Sys. wgt.	8.60	8.56	10.72	10.23	8.61	8.36	
Sv. thk.	.267	.284	.256	.398	.352	.305	
Final Design Point	x <sub>1</sub>	.1645	.1716	.1677	.2229	.1725	.1736
	x <sub>2</sub>	.0063	.0044	.0130	.0026	.0026	.0015
	x <sub>3</sub>	.0325**	.0536	.0363	.0517	.1334	.0499
	x <sub>4</sub>	.0044	.0044	.0130	.0026	.0026	.0015
	x <sub>5</sub>	.0600	.0500	.0260	.1186	.0410	.0784
	x <sub>6</sub>	1.0532	1.2621	.5614	1.645	1.3115	1.2215
Critical Func. Val./ Crit. time	f <sub>1</sub>	.010/900*	.131/900+	.219/900	.015/2400*	.066/900*	.164/900+
	f <sub>2</sub>	.011/900*	.043/900*	.012/900*	.066/2400*	.009/900*	.065/900*
	f <sub>3</sub>	.065/847*	.116/851+	.893/56	.134/669+	.561/132	.075/843*
	f <sub>4</sub>	.319/349	.368/370	.248/348	.504/1153	.446/388	.637/385
	f <sub>5</sub>	.751/1	.606/5	.896/50	.222/1	.146/5+	.199/853+
	f <sub>6</sub>	.991/867	.980/870	.999/885	.995/2019	.951/843	.797/843
	f <sub>7</sub>	.576/847	.606/843	.876/5	.378/1	.449/5	.126/853+
	f <sub>8</sub>	.609/350	.628/387	.585/360	.667/1	.657/388	.711/392
	f <sub>9</sub>	.937/60	.939/16	.941/15	.942/121	.947/5	.944/16

TABLE 4.1 (Concluded) Summary of Test cases treated

\* active behavior constraint; + nearly active behavior constraints; \*\* active side constraint

CASE	Init. P	Final R	Red. Fac. c	Init. Obj.Func.Val	Final Obj.Func.Val	% Red. in Obj.Func.Val	Run time hours
T1	$1 \times 10^6$	$1 \times 10^{-4}$	100	12.80	9.82	23.6	1.5
T2	$1 \times 10^6$	$1 \times 10^{-8}$	100	.356	.221	38.0	1.75
T3	$1 \times 10^6$	$1 \times 10^{-6}$	100	13.28	9.97	24.9	1.54
T4	$1 \times 10^{-2}$	$1 \times 10^{-6}$	100	11.80	9.78	17.1	1.34
T5	$1 \times 10^{-4}$	$1 \times 10^{-8}$	100	11.33	10.93	3.5	0.50
S1	$1 \times 10^4$	$1 \times 10^{-8}$	100	14.52	8.68	40.2	2.56
S2	$1 \times 10^4$	$1 \times 10^{-8}$	100	14.52	8.60	40.6	3.22
S3	$1 \times 10^4$	$1 \times 10^{-6}$	100	18.20	8.56	53.0	2.06
S4	1.0	$1 \times 10^{-8}$	100	.660	.256	61.6	1.61
S5	$1 \times 10^{-4}$	$1 \times 10^{-6}$	100	10.55	10.23	3.1	0.50
S6	$1 \times 10^{-2}$	$1 \times 10^{-10}$	100	18.08	8.61	52.3	2.42
S7	$1 \times 10^4$	$1 \times 10^{-6}$	100	13.44	8.36	37.8	1.45

TABLE 4.2

Penalty function parameters, % improvement in obj. func., run times

Cycle	0(Init.pt.)	1	2	3	4	5	6(fin.pt.)	
r	$1 \times 10^4$	$1 \times 10^4$	$1 \times 10^2$	$1 \times 10^0$	$1 \times 10^{-2}$	$1 \times 10^{-4}$	$1 \times 10^{-6}$	
P(x,r)	$1.337 \times 10^8$	$1.335 \times 10^8$	$1.308 \times 10^6$	$1.290 \times 10^4$	$1.407 \times 10^2$	10.120	8.572	
F(x)	18.20	20.42	20.76	20.64	11.85	8.63	8.56	
Design Point	x <sub>1</sub>	.25	.3260	.3504	.3666	.2276	.1724	.1716
	x <sub>2</sub>	.03	.0319	.0295	.0254	.0082	.0047	.0044
	x <sub>3</sub>	.25	.0844	.0552	.0400	.0711	.0544	.0536
	x <sub>4</sub>	.03	.0319	.0295	.0254	.0082	.0047	.0044
	x <sub>5</sub>	.10	.0952	.0944	.0933	.0572	.0431	.0500
	x <sub>6</sub>	2.00	1.7333	1.3059	.9570	.9219	1.2542	1.2621
Crit.behav./Crit. time	f <sub>1</sub>	.549/900	.550/900	.550/900	.550/900	.537/900	.167/900 <sup>+</sup>	.131/900 <sup>+</sup>
	f <sub>2</sub>	.182/1 <sup>+</sup>	.182/900 <sup>+</sup>	.182/900 <sup>+</sup>	.182/900 <sup>+</sup>	.182/900 <sup>+</sup>	.027/900 <sup>*</sup>	.043/900 <sup>*</sup>
	f <sub>3</sub>	.751/1	.553/82	.691/131	.813/303	.761/156	.197/847 <sup>+</sup>	.116/851 <sup>+</sup>
	f <sub>4</sub>	.228/900	.340/900	.371/900	.391/900	.343/703	.362/370	.368/370
	f <sub>5</sub>	.851/1	.906/1	.920/1	.913/1	.712/5	.627/5	.606/5
	f <sub>6</sub>	1.0/0	1.0/0	1.0/0	1.0/0	1.0/0	.984/857	.986/868
	f <sub>7</sub>	.934/1	.884/7	.885/93	.887/7	.763/5	.636/847	.606/843
	f <sub>8</sub>	.576/900	.636/900	.642/900	.630/1	.620/711	.626/387	.628/387
	f <sub>9</sub>	.971/5	.946/7	.939/7	.935/7	.939/5	.939/5	.939/16

TABLE 4.3 Summary of complete design path (Case S3)

THE REFERENCE MATRIX OF TRAJECTORY DEPENDENT THERMAL AND MECHANICAL LOADINGS (LDREF)

NO.	TMREF SECONDS	QCREF BTU/SQ-FT-SEC	QRREF BTU/SQ-FT-SEC	VELREF FT/SEC	RHOREF LBS/CU)FT	PRF IN.OF HG.	ALTITUDE FEET
1	.00	.00	.00	37000.0	.11640-08	.63050-06	400000.0
2	50.00	200.00	60.00	37000.0	.12460-04	.30550-03	262500.0
3	100.00	500.00	310.00	35000.0	.16960-04	.58460-02	200000.0
4	130.00	400.00	170.00	31000.0	.20470-04	.71400-02	195000.0
5	170.00	240.00	30.00	25700.0	.11750-04	.38790-02	210000.0
6	200.00	170.00	15.00	26500.0	.80360-05	.25230-02	220000.0
7	250.00	100.00	5.00	25500.0	.35350-05	.99550-03	240000.0
8	300.00	60.00	.00	25000.0	.12460-05	.30550-03	262500.0
9	350.00	40.00	.00	25000.0	.46610-06	.11430-03	280000.0
10	400.00	30.00	.00	25000.0	.26600-06	.65240-04	290000.0
11	450.00	25.00	.00	25000.0	.14880-06	.37370-04	300000.0
12	500.00	25.00	.00	25000.0	.14880-06	.37370-04	300000.0
13	550.00	30.00	.00	24900.0	.26600-06	.65240-04	290000.0
14	600.00	40.00	.00	24800.0	.40510-06	.99370-04	282500.0
15	650.00	60.00	.00	24500.0	.10820-05	.26550-03	265000.0
16	700.00	90.00	.00	24000.0	.35350-05	.99550-03	240000.0
17	725.00	115.00	.00	23800.0	.65980-05	.20180-02	225000.0
18	750.00	135.00	.00	23000.0	.11750-04	.38790-02	210000.0
19	775.00	162.00	.00	22000.0	.49260-04	.18100-01	171000.0
20	800.00	175.00	.00	20000.0	.66680-04	.24980-01	162500.0
21	820.00	120.00	.00	16300.0	.16990-03	.59470-01	140000.0
22	840.00	70.00	.00	11500.0	.41510-03	.13570-00	120000.0
23	860.00	35.00	.00	6500.0	.10670-02	.32900-00	100000.0
24	880.00	.00	.00	3300.0	.30080-02	.90850-00	78000.0
25	900.00	.00	.00	1500.0	.57160-02	.16820+01	65000.0

Table 4.4 Trajectory I Data



THE REFERENCE MATRIX OF TRAJECTORY DEPENDENT THERMAL AND MECHANICAL LOADINGS (LDREF)

NO.	TMREF SECONDS	QCREF BTU/SQ-FT-SEC	QRREF BTU/SQ-FT-SEC	VELREF FT/SEC	RHOREF LBS/CU-FT	PREF IN. OF HG.	PDYNREF LBS/SQ-FT
1	.00	.00	.00	26500.0	.11640-08	.00000	.0
2	50.00	2.50	.00	26500.0	.45610-08	.00000	20.0
3	125.00	10.00	.00	26500.0	.23790-07	.00000	110.0
4	187.00	20.00	5.00	26500.0	.14880-06	.00000	100.0
5	250.00	40.00	7.50	26500.0	.61710-06	.00000	95.0
6	325.00	72.00	7.00	26500.0	.16300-05	.00000	80.0
7	500.00	62.00	6.00	26000.0	.16300-05	.00000	60.0
8	750.00	58.00	5.00	25500.0	.16300-05	.00000	50.0
9	875.00	56.00	4.80	25000.0	.16300-05	.00000	50.0
10	1000.00	61.00	4.50	24000.0	.16300-05	.00000	50.0
11	1250.00	78.00	3.00	22000.0	.65980-05	.00000	45.0
12	1375.00	80.00	2.50	20000.0	.97390-05	.00000	40.0
13	1500.00	70.00	2.40	18000.0	.16960-04	.00000	40.0
14	1750.00	48.00	1.00	14000.0	.35560-04	.00000	40.0
15	2000.00	23.00	.00	10000.0	.74710-04	.00000	40.0
16	2250.00	.5.00	.00	5000.0	.33010-03	.00000	50.0
17	2400.00	.00	.00	.0	.76470-01	.00000	10.0

Table 4.5 Trajectory II Data

DATA FOR AEROTHERMOELASTIC PANEL SYNTHESIS PROGRAM

NUMBER OF FINITE DIFFERENCE STATIONS IN ABLATOR=M= 15  
 TOTAL NUMBER OF FINITE DIFFERENCE STATIONS=N= 25  
 NUMBER OF TIME REFERENCE VALUES=R1= 25  
 NUMBER OF TEMP. REFERENCE VALUES=R2= 15  
 NUMBER OF REENTRY PATHS CONSIDERED=L= 1  
 THE NUMBER OF DESIGN VARIABLES=NDV= 4

LAM= 1.8750	RHOI= 6.00 LBS/CUBIC FOOT
RHOS= 172.80 LRS/CUBIC FOOT	ETA1= .60
ETA2= .60	AA= .447+05
RR= .400+05	SIGMA= .480-12 BTU/SQ-FT*SEC*(R**4)
EPS= .80	DHC= 2000.0 BTU/LB
CE= .232	RHOAVP= 36.00 LBS/CUBIC FOOT
RHOAC= 20.00 LRS/CUBIC FOOT	TSMAX= 1200.00 DEGREES RANKINE
TBMAX= 660.00 DEGREES RANKINE	WMAX= .020 FEET

THE ALLOWABLE TOTAL WALL THICKNESS IS .10000+01 FT.  
 THE WEIGHT OF THE PANEL SUPPORT SYSTEM PER FOOT OF PERIMETER IS .10000+01 LBS.  
 THE GREATEST REAL NUMBER IS .10000+32

TCURE= .81000+03 DEGREES R  
 TPLAS= .90000+03 DEGREES R  
 OTIM= .50000+01 SEC.  
 GRAT= .10000+01  
 PRAT= .10000+01  
 CC= 100.00  
 FIX= 0  
 WGT= 1  
 PCALC= 1

THE INITIAL TEMPERATURE DISTRIBUTION (TINT) IS

.5400+03	.5400+03	.5400+03	.5400+03	.5400+03	.5400+03	.5400+03	.5400+03	.5400+03	.5400+03	.5400+03
.5400+03	.5400+03	.5400+03	.5400+03	.5400+03	.5400+03	.5400+03	.5400+03	.5400+03	.5400+03	.5400+03
.5400+03	.5400+03	.5400+03	.5400+03	.5400+03	.5400+03	.5400+03	.5400+03	.5400+03	.5400+03	.5400+03

THE INITIAL VALUE OF R IS .100-05  
 THE FIRST GUESS MOVE LENGTH=T= .10000-02

THE INITIAL DESIGN POINT IS .21508 .00181 .07561 .67360 .00000 .00000 .00000

LOWER ROUNDS ON THE DESIGN VARIABLES ARE

.10000+00	.10000-02	.10000-01	.50000-00	.00000	.00000	.00000
-----------	-----------	-----------	-----------	--------	--------	--------

UPPER ROUNDS ON THE DESIGN VARIABLES ARE

.40000-00	.20000-01	.20000-00	.30000+01	.00000	.00000	.00000
-----------	-----------	-----------	-----------	--------	--------	--------

THE COORDINATE INCREMENTS ARE

.10000-01	.10000+00	.20000-00	.50000-01	.00000	.00000	.00000
-----------	-----------	-----------	-----------	--------	--------	--------

Table 4.6 Miscellaneous Properties: LDPN ablator, aluminum thin sheet substrate, microquartz ins. (with Trajectory I)

DATA FOR AEROTHERMOELASTIC PANEL SYNTHESIS PROGRAM

NUMBER OF FINITE DIFFERENCE STATIONS IN ABLATOR=M= 15  
 TOTAL NUMBER OF FINITE DIFFERENCE STATIONS=N= 25  
 NUMBER OF TIME REFERENCE VALUES=R1= 17  
 NUMBER OF TEMP. REFERENCE VALUES=R2= 15  
 NUMBER OF REENTRY PATHS CONSIDERED=L= 1  
 THE NUMBER OF DESIGN VARIABLES=NDV= 4

LAM= 1.8750  
 RHOS= 110.00 LBS/CUBIC FOOT  
 ETA2= .60  
 HH= .400+05  
 EPS= .80  
 CE= .232  
 RHOAC= 20.00 LBS/CUBIC FOOT  
 THMAX= 660.00 DEGREES RANKINE

RHOI= 6.00 LBS/CUBIC FOOT  
 ETA1= .60  
 AA= .447+05  
 SIGMA= .480-12 BTU/SA-FT\*SEC\*(R\*\*4)  
 DHC= 2000.0 BTU/LB  
 RHOAVP= 36.00 LBS/CUBIC FOOT  
 TSMAX= 1200.00 DEGREES RANKINE  
 WMAX= .020 FEET

THE ALLOWABLE TOTAL WALL THICKNESS IS .10000+01 FT.  
 THE WEIGHT OF THE PANEL SUPPORT SYSTEM PER FOOT OF PERIMETER IS .10000+01 LBS.  
 THE GREATEST REAL NUMBER IS .10000+32

TCURE= .81000+03 DEGREES R  
 TPLAS= .90000+03 DEGREES R  
 OTIM= .10000+02 SEC.  
 GRAT= .10000+01  
 PRAT= .10000+01  
 CC= 100.00  
 FIX= 0  
 WGT= 1  
 PCALC= 0

THE INITIAL TEMPERATURE DISTRIBUTION (TINT) IS

.5400+03	.5400+03	.5400+03	.5400+03	.5400+03	.5400+03	.5400+03	.5400+03	.5400+03	.5400+03
.5400+03	.5400+03	.5400+03	.5400+03	.5400+03	.5400+03	.5400+03	.5400+03	.5400+03	.5400+03
.5400+03	.5400+03	.5400+03	.5400+03	.5400+03					

THE INITIAL VALUE OF R IS .100-03  
 THE FIRST GUESS MOVE LENGTH=T= .10000-01

THE INITIAL DESIGN POINT IS .23000 .01200 .15000 1.20000 .00000 .00000 .00000

LOWER BOUNDS ON THE DESIGN VARIABLES ARE  
 .10000+00 .16700-02 .10000-01 .50000-00 .00000 .00000 .00000

UPPER BOUNDS ON THE DESIGN VARIABLES ARE  
 .50000-00 .50000-01 .40000-00 .30000+01 .00000 .00000 .00000

THE COORDINATE INCREMENTS ARE  
 .10000-01 .10000+00 .10000+00 .50000-01 .00000 .00000 .00000

Table 4.7 Miscellaneous Properties: LDPN ablator, fiberglass thin sheet substructure, microquartz insulation (includes data for Trajectory II)

DATA FOR AEROTHERMOELASTIC PANEL SYNTHESIS PROGRAM

NUMNER OF FINITE DIFFERENCE STATIONS IN ABLATOR=M= 15  
 TOTAL NUMBER OF FINITE DIFFERENCE STATIONS=N= 26  
 NUMBER OF TIME REFERENCE VALUES=R1= 25  
 NUMNER OF TEMP. REFERENCE VALUES=R2= 15  
 NUMNER OF REENTRY PATHS CONSIDERED=L= 1  
 THE NUMBER OF DESIGN VARIABLES=NDV= 5

LAM= 1.8750	RHOI= 6.00LBS/CUBIC FOOT
RHOS= 172.80LBS/CUBIC FOOT	ETA1= .60
ETA2= .60	AA= .447+05
RR= .400+05	SIGMA= .480-12BTU/SQ-FT*SEC*(R**4)
FPS= .80	DHC= 2000.0BTU/LA
CE= .232	RHOAVP= 36.00LBS/CUBIC FOOT
RHOAC= 20.00LBS/CUBIC FOOT	TSMAX= 1200.00DEGREES RANKINE
TRMAX= 660.00DEGREES RANKINE	WMAX= .020FEET

THE ALLOWABLE TOTAL WALL THICKNESS IS .10000+01 FT.  
 THE WEIGHT OF THE PANEL SUPPORT SYSTEM PER FOOT OF PERIMETER IS .10000+01 LBS.  
 THE GREATEST REAL NUMNER IS .10000+32  
 THE DENSITY OF THE CORE(RHOC) IS .60000+01 LBS/CU.FT.  
 THE CORE CELL DIAMETER(CELDIA) IS .20800-01 FT.  
 THE CORE SOLIDITY RATIO (SR) IS .10000+00  
 THE DENSITY OF THE LOWER SANDWICH FACE (RH04) IS .17280+03 LBS/CU.FT.  
 TCURE= .81000+03 DEGREES R  
 TPLAS= .90000+03 DEGREES R  
 OTIM= .50000+01 SEC.  
 GRAT= .10000+01  
 PRAT= .10000+01  
 CC= 100.00  
 FIX= 0  
 WGT= 1  
 PCALC= 1

THE INITIAL TEMPERATURE DISTRIBUTION (TINT) IS

.5400+03	.5400+03	.5400+03	.5400+03	.5400+03	.5400+03	.5400+03	.5400+03	.5400+03	.5400+03
.5400+03	.5400+03	.5400+03	.5400+03	.5400+03	.5400+03	.5400+03	.5400+03	.5400+03	.5400+03
.5400+03	.5400+03	.5400+03	.5400+03	.5400+03	.5400+03	.5400+03	.5400+03	.5400+03	.5400+03

THE INITIAL VALUE OF R IS .100-05  
 THE FIRST GUESS MOVE LENGTH=T= .10000-01

THE INITIAL DESIGN POINT IS .17357 .00150 .04992 .00150 .07842 1.22152 .00000

LOWER ROUNDS ON THE DESIGN VARIABLES ARE

.10000+00	.10000-02	.31250-01	.10000-02	.10000-01	.50000-00	.00000
-----------	-----------	-----------	-----------	-----------	-----------	--------

UPPER ROUNDS ON THE DESIGN VARIABLES ARE

.40000-00	.40000-01	.30000-00	.40000-01	.20000-00	.30000+01	.10000+02
-----------	-----------	-----------	-----------	-----------	-----------	-----------

THE COORDINATE INCREMENTS ARE

.10000-01	.10000-01	.10000-01	.10000-01	.20000-01	.10000-01	.00000
-----------	-----------	-----------	-----------	-----------	-----------	--------

Table 4.8 Miscellaneous Data and Properties: LDPN ablator, aluminum sandwich substrate, microquartz insulator, Trajectory I.

DATA FOR AEROTHERMOELASTIC PANEL SYNTHESIS PROGRAM

NUMBER OF FINITE DIFFERENCE STATIONS IN ABLATOR=M= 15  
 TOTAL NUMBER OF FINITE DIFFERENCE STATIONS=N= 26  
 NUMBER OF TIME REFERENCE VALUES=R1= 17  
 NUMBER OF TEMP. REFERENCE VALUES=R2= 15  
 NUMBER OF REENTRY PATHS CONSIDERED=L= 1  
 THE NUMBER OF DESIGN VARIABLES=NDV= 5

LAM= 1.8750  
 RHOS= 110.00LBS/CUBIC FOOT  
 ETA2= .60  
 RB= .400+05  
 EPS= .80  
 CE= .232  
 RHOAC= 20.00LBS/CUBIC FOOT  
 TRMAX= 660.00DEGREES RANKINE  
 RHOI= 6.00LBS/CUBIC FOOT  
 ETA1= .60  
 AA= .447+05  
 SIGMA= .480-12BTU/SQ-FT\*SEC\*(R\*\*4)  
 DHC= 2000.0BTU/LB  
 RHOAVP= 36.00LBS/CUBIC FOOT  
 TSMAX= 1200.00DEGREES RANKINE  
 WMAX= .020FEET

THE ALLOWABLE TOTAL WALL THICKNESS IS .10000+01 FT.  
 THE HEIGHT OF THE PANEL SUPPORT SYSTEM PER FOOT OF PERIMETER IS .10000+01 LBS.  
 THE GREATEST REAL NUMBER IS .10000+32  
 THE DENSITY OF THE CORE(RHOC)IS .60000+01 LBS/CU.FT.  
 THE CORE CELL DIAMETER(CEL DIA)IS .20800-01 FT.  
 THE CORE SOLIDITY RATIO (SR) IS .10000+00  
 THE DENSITY OF THE LOWER SANDWICH FACE (RH04) IS .11000+03 LBS/CU.FT.  
 TCURE= .81000+03 DEGREES R  
 TPLAS= .90000+03 DEGREES R  
 NTIM= .10000+02 SEC.  
 GRAT= .10000+01  
 PRAT= .10000+01  
 CC= 100.00  
 FIX= 0  
 WGT= 1  
 PCALC= 0

THE INITIAL TEMPERATURE DISTRIBUTION (TINT) IS

.5400+03	.5400+03	.5400+03	.5400+03	.5400+03	.5400+03	.5400+03	.5400+03	.5400+03	.5400+03
.5400+03	.5400+03	.5400+03	.5400+03	.5400+03	.5400+03	.5400+03	.5400+03	.5400+03	.5400+03
.5400+03	.5400+03	.5400+03	.5400+03	.5400+03	.5400+03	.5400+03	.5400+03	.5400+03	.5400+03

THE INITIAL VALUE OF R IS .100-03  
 THE FIRST GUESS MOVE LENGTH=T= .50000-02

THE INITIAL DESIGN POINT IS .23000 .00300 .05000 .00300 .12000 1.70000 -.00000

LOWER BOUNDS ON THE DESIGN VARIABLES ARE

.10000+00	.10000-02	.31250-01	.10000-02	.10000-01	.50000-00	.00000
-----------	-----------	-----------	-----------	-----------	-----------	--------

UPPER BOUNDS ON THE DESIGN VARIABLES ARE

.40000-00	.40000-01	.30000-00	.40000-01	.20000-00	.30000+01	.10000+02
-----------	-----------	-----------	-----------	-----------	-----------	-----------

THE COORDINATE INCREMENTS ARE

.10000-01	.10000-01	.10000-01	.10000-01	.20000-01	.10000-01	.00000
-----------	-----------	-----------	-----------	-----------	-----------	--------

Table 4.9 Miscellaneous Data and Material Properties: LDPN ablator, Fiberglass sandwich substrate, and microquartz insulator, Trajectory II.

THE REFERENCE MATRIX OF THERMAL AND MECHANICAL PROPERTIES FOR THE ABLATOR (MAREF)

NO.	TRFF DEGREFS R	KA BTU/FT-SEC-R	CPA BTU/LH-R	ETA KSI	ECA KSI	STUA KSI	EPSTUA	SCUA KSI	EPSCUA	ALPHA 1/R
1	360.0	.180-04	.240-00	160.0	240.0	1.3	.00870	5.08	.02500	.200-04
2	460.0	.200-04	.300-00	140.0	160.0	1.2	.00950	5.00	.04600	.300-04
3	560.0	.210-04	.360-00	100.0	110.0	1.1	.01600	3.70	.08000	.300-04
4	700.0	.210-04	.440-00	35.0	55.0	.7	.04500	3.00	.79000	.000
5	800.0	.210-04	.500-00	12.0	45.0	.3	.06000	2.70	.20000	.000
6	1000.0	.300-04	.600-00	3.0	12.0	.1	.05000	.50	.20000	-.300-04
7	1195.0	.400-04	.700-00	.0	6.0	.0	.07000	.06	.20000	-.300-04
8	1200.0	.400-04	.270+01	.0	6.0	.0	.07000	.00	1.00000	-.300-04
9	1400.0	.450-04	.280+01	.0	.0	.0	1.00000	.00	1.00000	-.400-04
10	1405.0	.450-04	.800-00	.0	.0	.0	1.00000	.00	1.00000	-.400-04
11	1460.0	.460-04	.800-00	.0	.0	.0	1.00000	.00	1.00000	-.400-04
12	2460.0	.290-03	.800-00	.0	.0	.0	1.00000	.00	1.00000	-.400-04
13	3460.0	.700-03	.800-00	.0	.0	.0	1.00000	.00	1.00000	-.400-04
14	3900.0	.100-02	.800-00	.0	.0	.0	1.00000	.00	1.00000	-.400-04
15	7000.0	.100-02	.800-00	.0	.0	.0	1.00000	.00	1.00000	-.400-04

Table 4.10 LDPN ablator temperature dependent properties

THE REFERENCE MATRIX OF THERMAL AND MECHANICAL PROPERTIES FOR THE BACK-UP SHEET (MSREF)

NO.	TREF DEGREES R	CPS ATU/LA-R	ES KSI	SUS KSI	ALPHAS 1/R
1	360.0	.175-00	.114+05	45.0	.120-04
2	460.0	.195-00	.107+05	45.0	.120-04
3	560.0	.215-00	.102+05	45.0	.120-04
4	700.0	.225-00	.101+05	41.0	.120-04
5	800.0	.230-00	.980+04	38.0	.120-04
6	1000.0	.240-00	.790+04	18.0	.130-04
7	1195.0	.265-00	.570+04	6.8	.140-04
8	1200.0	.266-00	.550+04	6.7	.140-04
9	1400.0	.305-00	.000	.0	.150-04
10	1405.0	.306-00	.000	.0	.150-04
11	1460.0	.325-00	.000	.0	.150-04
12	2460.0	.325-00	.000	.0	.150-04
13	3460.0	.325-00	.000	.0	.150-04
14	3900.0	.325-00	.000	.0	.150-04
15	7000.0	.325-00	.000	.0	.150-04

Table 4.11 Temperature Dependent properties for the thin sheet aluminum structure.

THE REFERENCE MATRIX OF THERMAL AND MECHANICAL PROPERTIES FOR THE HACK-UP SHEET (MSWEP)

NO.	TREF DEGREES R	CPS HTU/LR-R	ES KSI	SUS KSI	ALPHAS 1/R
1	360.0	.190-00	.330+04	20.0	.510-05
2	460.0	.200-00	.330+04	20.0	.510-05
3	560.0	.210-00	.320+04	15.0	.510-05
4	700.0	.240-00	.300+04	13.0	.500-05
5	800.0	.270-00	.290+04	15.0	.450-05
6	1000.0	.280-00	.280+04	14.0	.400-05
7	1195.0	.300-00	.220+04	18.0	.350-05
8	1200.0	.300-00	.220+04	18.0	.350-05
9	1400.0	.300-00	.500+03	11.0	.300-05
10	1405.0	.300-00	.500+03	11.0	.300-05
11	1460.0	.300-00	.100+03	4.0	.300-05
12	2460.0	.300-00	.000	.0	.300-05
13	3460.0	.300-00	.000	.0	.300-05
14	3900.0	.300-00	.000	.0	.300-05
15	7000.0	.300-00	.000	.0	.300-05

Table 4.12 Temperature Dependent Properties for the fiber glass thin sheet structure



THE REFERENCE MATRIX OF THERMAL AND MECHANICAL PROPERTIES FOR THE UPPER SANDWICH FACE (MSREF)

NO.	TREF DEGREES R	CPS ATU/LA-R	ES KSI	SUS KSI	ALPHAS 1/R
1	360.0	.175-00	.114+05	45.0	.120-04
2	460.0	.195-00	.107+05	45.0	.120-04
3	560.0	.215-00	.102+05	45.0	.120-04
4	700.0	.225-00	.101+05	41.0	.120-04
5	800.0	.230-00	.980+04	38.0	.120-04
6	1000.0	.240-00	.790+04	18.0	.130-04
7	1195.0	.265-00	.570+04	6.8	.140-04
8	1200.0	.266-00	.550+04	6.7	.140-04
9	1400.0	.305-00	.000	.0	.150-04
10	1405.0	.306-00	.000	.0	.150-04
11	1460.0	.325-00	.000	.0	.150-04
12	2460.0	.325-00	.000	.0	.150-04
13	3460.0	.325-00	.000	.0	.150-04
14	3900.0	.325-00	.000	.0	.150-04
15	7000.0	.325-00	.000	.0	.150-04

Table 4.13 Temperature dependent properties for the aluminum sandwich structure.

THE REFERENCE MATRIX OF THERMAL AND MECHANICAL PROPERTIES FOR THE CORE (MCREF)

NO.	TREF DEGREES R	KCORE BTU/FT-SEC-R	KAIR BTU/FT-SEC-R	EMISSIVITY	G KSI	SZYU KSI
1	360.0	.100-01	.200-05	.70	.650+02	.25
2	460.0	.200-01	.360-05	.70	.600+02	.25
3	560.0	.222-01	.420-05	.70	.500+02	.25
4	700.0	.300-01	.500-05	.70	.400+02	.22
5	800.0	.300-01	.610-05	.70	.350+02	.18
6	1000.0	.200-01	.720-05	.70	.250+02	.16
7	1195.0	.200-01	.810-05	.70	.200+02	.12
8	1200.0	.200-01	.820-05	.70	.200+02	.12
9	1400.0	.100-01	.940-05	.70	.000	.00
10	1405.0	.100-01	.120-04	.70	.000	.00
11	1460.0	.500-02	.150-04	.70	.000	.00
12	2460.0	.100-02	.150-04	.70	.000	.00
13	3400.0	.100-02	.150-04	.70	.000	.00
14	3900.0	.100-02	.150-04	.70	.000	.00
15	7000.0	.100-02	.150-04	.70	.000	.00

Table 4.13 Continued

THE REFERENCE MATRIX OF THERMAL AND MECHANICAL PROPERTIES FOR THE LOWER SANDWICH FACE (M4REF)

NO.	TREF DEGREES R	CP4 BTU/LB-R	E4 KSI	SU4 KSI	ALPHA4 1/R
1	360.0	.175-00	.114+05	45.0	.120-04
2	460.0	.195-00	.107+05	45.0	.120-04
3	560.0	.215-00	.102+05	45.0	.120-04
4	700.0	.225-00	.101+05	41.0	.120-04
5	800.0	.230-00	.980+04	38.0	.120-04
6	1000.0	.240-00	.790+04	18.0	.130-04
7	1195.0	.265-00	.570+04	6.8	.140-04
8	1200.0	.266-00	.550+04	6.7	.140-04
9	1400.0	.305-00	.000	.0	.150-04
10	1405.0	.306-00	.000	.0	.150-04
11	1460.0	.325-00	.000	.0	.150-04
12	2460.0	.325-00	.000	.0	.150-04
13	3460.0	.325-00	.000	.0	.150-04
14	3900.0	.325-00	.000	.0	.150-04
15	7000.0	.325-00	.000	.0	.150-04

Table 4.13 Concluded

THE REFERENCE MATRIX OF THERMAL AND MECHANICAL PROPERTIES FOR THE UPPER SANDWICH FACE (MSNEF)

NO.	TREF DEGREES R	CPS BTU/L.R-R	ES KSI	SUS KSI	ALPHAS 1/R
1	360.0	.190-00	.330+04	20.0	.510-05
2	460.0	.200-00	.330+04	20.0	.510-05
3	560.0	.210-00	.320+04	15.0	.510-05
4	700.0	.240-00	.300+04	13.0	.500-05
5	800.0	.270-00	.290+04	15.0	.450-05
6	1000.0	.280-00	.280+04	14.0	.400-05
7	1195.0	.300-00	.220+04	18.0	.350-05
8	1200.0	.300-00	.220+04	18.0	.350-05
9	1400.0	.300-00	.500+03	11.0	.300-05
10	1405.0	.300-00	.500+03	11.0	.300-05
11	1460.0	.300-00	.100+03	4.0	.300-05
12	2460.0	.300-00	.000	.0	.300-05
13	3460.0	.300-00	.000	.0	.300-05
14	3900.0	.300-00	.000	.0	.300-05
15	7000.0	.300-00	.000	.0	.300-05

Table 4.14 Temperature Dependent Properties for the fiberglass sandwich structure

## THE REFERENCE MATRIX OF THERMAL AND MECHANICAL PROPERTIES FOR THE CORE (MCREF)

NO.	TREF DEGREES R	KCORE BTU/FT-SEC-R	KAIR BTU/FT-SEC-R	EMISSIVITY	G KSI	SZXU KSI
1	360.0	.100-03	.200-05	.70	.900+01	.10
2	460.0	.200-03	.360-05	.70	.800+01	.10
3	560.0	.250-03	.420-05	.70	.700+01	.10
4	700.0	.300-03	.500-05	.70	.700+01	.10
5	800.0	.200-03	.610-05	.70	.700+01	.08
6	1000.0	.150-03	.720-05	.70	.600+01	.06
7	1195.0	.100-03	.810-05	.70	.500+01	.05
8	1200.0	.100-03	.820-05	.70	.400+01	.05
9	1400.0	.600-04	.940-05	.70	.400+01	.03
10	1405.0	.500-04	.950-05	.70	.300+01	.03
11	1460.0	.100-04	.120-04	.70	.200+01	.02
12	2460.0	.100-04	.150-04	.70	.000	.00
13	3460.0	.100-04	.150-04	.70	.000	.00
14	3900.0	.100-04	.150-04	.70	.000	.00
15	7000.0	.100-04	.150-04	.70	.000	.00

Table 4.14 Continued

THE REFERENCE MATRIX OF THERMAL AND MECHANICAL PROPERTIES FOR THE LOWER SANDWICH FACE (M4REF)

NO.	TREF DEGREES R	CP4 BTU/LB-R	E4 KSI	SU4 KSI	ALPHA4 1/R
1	360.0	.190-00	.330+04	20.0	.510-05
2	460.0	.200-00	.330+04	20.0	.510-05
3	560.0	.210-00	.320+04	15.0	.510-05
4	700.0	.240-00	.300+04	13.0	.500-05
5	800.0	.270-00	.290+04	15.0	.450-05
6	1000.0	.280-00	.280+04	14.0	.400-05
7	1195.0	.300-00	.220+04	18.0	.350-05
8	1200.0	.300-00	.220+04	18.0	.350-05
9	1400.0	.300-00	.500+03	11.0	.300-05
10	1405.0	.300-00	.500+03	11.0	.300-05
11	1460.0	.300-00	.100+03	4.0	.300-05
12	2460.0	.300-00	.000	.0	.300-05
13	3460.0	.300-00	.000	.0	.300-05
14	3900.0	.300-00	.000	.0	.300-05
15	7000.0	.300-00	.000	.0	.300-05

Table 4.14 Concluded

THE REFERENCE MATRIX OF THERMAL AND MECHANICAL PROPERTIES FOR THE INSULATOR (MIREF)

NO.	TREF DEG. R	KI BTU/FT-SEC-R	CPI BTU/LB-R
1	360.0	.450-05	.400-00
2	460.0	.750-05	.400-00
3	560.0	.830-05	.400-00
4	700.0	.103-04	.400-00
5	800.0	.117-04	.400-00
6	1000.0	.400-04	.400-00
7	1195.0	.400-04	.400-00
8	1200.0	.400-04	.400-00
9	1400.0	.450-04	.400-00
10	1405.0	.450-04	.400-00
11	1460.0	.460-04	.400-00
12	2460.0	.290-03	.400-00
13	3460.0	.700-03	.400-00
14	3900.0	.100-02	.400-00
15	7000.0	.100-02	.400-00

Table 4.15 Temperature Dependent Properties for microquartz insulation

## THE REFERENCE MATRIX OF WALL ENTHALPY VALUES

NO.	TREF DEG. R	HW BTU/LB
1	360.0	.69400+02
2	460.0	.10120+03
3	560.0	.13300+03
4	700.0	.16860+03
5	800.0	.19400+03
6	1000.0	.24210+03
7	1195.0	.29000+03
8	1200.0	.29300+03
9	1400.0	.34300+03
10	1405.0	.34600+03
11	1460.0	.36400+03
12	2460.0	.64500+03
13	3460.0	.95000+03
14	3900.0	.11400+04
15	7000.0	.18000+04

Tab13 4.15 (Concluded) Wall enthalpy



DATA FOR THE CURRENT DESIGN SPACE POINT  
 THE CURRENT VALUE OF R IS .10000+07  
 THE CURRENT VALUE OF T IS .10000-01

DESIGN POINT COORDINATES (FEET)

XMIN	X	XMAX
.10000	.24999999	.50000
.00167	.02085000	.05000
.01000	.08500000	.40000
.50000	1.00000000	3.00000

SYSTEM WEIGHT= .12803+02 LBS/SQ-FT  
 FIACCO MC-CORMICK FUNCTION VALUE= .13215+11

BEHAVIOR CONSTRAINT INFORMATION

NUMBER	TYPE OF BEHAVIOR, UNITS	CRITICAL VALUE	LIMITING VALUE	TIME AT CRIT. VALUE	NORMALIZED VALUE
1	TEMP. AT ABL.-STR. INTERFACE (R)	.54199+03	.12000+04	900.00 SEC.	.54834-00
2	TEMP. AT RACK OF INSULATION (R)	.54004+03	.66000+03	900.00 SEC.	.18175-00
3	DISPLACEMENT AT PANEL CENTER (FT)	-.15688-01	.20000-01	845.20 SEC.	.21562-00
4	YIELD STRESS-STRUCTURE (KSI)	-.43104+01 -.75292+01	.16000+02	1.00 SEC.	.85514-00
5	YIELD STRESS-ABLATOR (KSI)	.90169-00 .94289-00	.11180+01 .39341+01	900.00 SEC.	.28873-00
7	TENSILE STRAIN-ABLATOR	.61014-02	.14700-01	5.30 SEC.	.58494-00
8	COMPRESSIVE STRAIN-ABLATOR	-.14270-01	.20000-00	107.37 SEC.	.92865-00

TOTAL ABLATFD DISTANCE IS .05902 FT.

TEMPERATURE DISTRIBUTION AT 900.00 SECONDS

.2234+04	.2548+04	.2660+04	.2648+04	.2534+04	.2315+04	.1963+04	.1299+04	.9304+03	.7173+03
.6205+03	.5769+03	.5565+03	.5469+03	.5420+03	.5413+03	.5409+03	.5406+03	.5404+03	.5402+03
.5402+03	.5401+03	.5401+03	.5400+03	.5400+03					

Table 4.16 Case T1 Initial Point

DATA FOR THE CURRENT DESIGN SPACE POINT  
 THE CURRENT VALUE OF R IS .10000-03  
 THE CURRENT VALUE OF T IS .50000-02

DESIGN POINT COORDINATES (FEET)

XMIN	X	XMAX
.10000	.19771700	.50000
.00167	.00592152	.05000
.01000	.04133654	.40000
.50000	.55416544	3.00000

SYSTEM WEIGHT= .98217+01 LBS/SQ-FT

FIACCO MC-CORMICK FUNCTION VALUE= .11076+02

BEHAVIOR CONSTRAINT INFORMATION

NUMBER	TYPE OF BEHAVIOR,UNITS	CRITICAL VALUE	LIMITING VALUE	TIME AT CRIT.VALUE	NORMALIZED VALUE
1	TEMP. AT ABL.-STR. INTERFACE (R)	.63938+03	.12000+04	900.00 SEC.	.46719-00
2	TEMP. AT RACK OF INSULATION (R)	.57799+03	.66000+03	900.00 SEC.	.12426+00
3	DISPLACEMENT AT PANEL CENTER (FT)	-.16041-01	.20000-01	850.59 SEC.	.19797-00
4	YIELD STRESS-STRUCTURE (KSI)	-.74432+01 -.13579+02	.16000+02	1.00 SEC.	.48292-00
5	YIELD STRESS-ABLATOR (KSI)	.90426-00 .88421-00	.11173+01 .39254+01	484.74 SEC.	.35925-00
7	TENSILE STRAIN-ABLATOR	.60525-02	.14700-01	124.85 SEC.	.58827-00
8	COMPRESSIVE STRAIN-ABLATOR	-.21520-01	.20000-00	850.59 SEC.	.89240-00

TOTAL ABLATED DISTANCE IS .05869 FT.

TEMPERATURE DISTRIBUTION AT 900.00 SECONDS

.2191+04	.2461+04	.2594+04	.2644+04	.2631+04	.2563+04	.2439+04	.2253+04	.2002+04	.1648+04
.1200+04	.9450+03	.7767+03	.6843+03	.6394+03	.6269+03	.6161+03	.6068+03	.5989+03	.5923+03
.5871+03	.5831+03	.5802+03	.5785+03	.5780+03					

Table 4.16b Case T1 Final Point

DATA FOR THE CURRENT DESIGN SPACE POINT  
 THE CURRENT VALUE OF R IS .10000+07  
 THE CURRENT VALUE OF T IS .80000-02

DESIGN POINT COORDINATES (FEET)

XMIN	X	XMAX
.10000	.24999999	.50000
.00167	.02085000	.05000
.01000	.08500000	.40000
.50000	.69499999	3.00000

SYSTEM THICKNESS= .35585-00 FT.

FIACCO MC-CORMICK FUNCTION VALUE= .12393+11

BEHAVIOR CONSTRAINT INFORMATION

NUMBER	TYPE OF BEHAVIOR+UNITS	CRITICAL VALUE	LIMITING VALUE	TIME AT CRIT.VALUE	NORMALIZED VALUE
1	TEMP. AT ABL.-STR. INTERFACE (R)	.54199+03	.12000+04	900.00 SEC.	.54834-00
2	TEMP. AT RACK OF INSULATION (R)	.54004+03	.66000+03	900.00 SEC.	.18175-00
3	DISPLACEMENT AT PANEL CENTER (FT)	-.62212-02	.20000-01	889.67 SEC.	.68894-00
4	YIELD STRESS-STRUCTURE (KSI)	-.43112+01 -.75294+01	.16000+02	1.00 SEC.	.85515-00
5	YIELD STRESS-ABLATOR (KSI)	.90944-00 .94518-00	.11183+01 .39374+01	881.66 SEC.	.28561-00
7	TENSILE STRAIN-ABLATOR	.61002-02	.14700-01	5.30 SEC.	.58502-00
8	COMPRESSIVE STRAIN-ABLATOR	-.14072-01	.20000-00	107.37 SEC.	.92964-00

TOTAL ABLATED DISTANCE IS .05902 FT.

TEMPERATURE DISTRIBUTION AT 900.00 SECONDS

.2234+04	.2548+04	.2660+04	.2648+04	.2534+04	.2315+04	.1963+04	.1299+04	.9304+03	.7173+03
.6205+03	.5769+03	.5565+03	.5469+03	.5420+03	.5413+03	.5409+03	.5406+03	.5404+03	.5402+03
.5402+03	.5401+03	.5401+03	.5400+03	.5400+03					

Table 4.17 Case T2 Initial Point

DATA FOR THE CURRENT DESIGN SPACE POINT  
 THE CURRENT VALUE OF R IS .10000-07  
 THE CURRENT VALUE OF T IS .20000-02

DESIGN POINT COORDINATES (FEET)

XMIN	X	XMAX
.10000	.19127508	.50000
.00167	.01633664	.05000
.01000	.01368721	.40000
.50000	.69499999	3.00000

SYSTEM THICKNESS= .22130-00 FT.

FIACCO MC-CORMICK FUNCTION VALUE= .22147-00

BEHAVIOR CONSTRAINT INFORMATION

NUMBER	TYPE OF BEHAVIOR+UNITS	CRITICAL VALUE	LIMITING VALUE	TIME AT CRIT.VALUE	NORMALIZED VALUE
1	TEMP. AT ABL.-STR. INTERFACE (R)	.64464+03	.12000+04	900.00 SEC.	.46280-00
2	TEMP. AT BACK OF INSULATION (R)	.63349+03	.66000+03	900.00 SEC.	.40165-01
3	DISPLACEMENT AT PANEL CENTER (FT)	-.19939-01	.20000-01	851.33 SEC.	.30567-02
4	YIELD STRESS-STRUCTURE (KSI)	.11340+02 .34073+01	.14112+02	851.33 SEC.	.47001-00
5	YIELD STRESS-ABLATOR (KSI)	.92519-00 .95713-00	.11168+01 .39183+01	494.51 SEC.	.26549-00
7	TENSILE STRAIN-ABLATOR	.60929-02	.14700-01	5.30 SEC.	.58552-00
6	COMPRESSIVE STRAIN-ABLATOR	-.15088-01	.20000-00	851.33 SEC.	.92456-00

TOTAL ABLATED DISTANCE IS .05874 FT.

TEMPERATURE DISTRIBUTION AT 900.00 SECONDS

.2212+04	.2475+04	.2610+04	.2667+04	.2666+04	.2617+04	.2521+04	.2376+04	.2176+04	.1910+04
.1497+04	.1137+04	.9022+03	.7439+03	.6446+03	.6425+03	.6406+03	.6389+03	.6375+03	.6363+03
.6353+03	.6345+03	.6339+03	.6336+03	.6335+03					

Table 4.17 (Concluded) Case T2 Final Point

DATA FOR THE CURRENT DESIGN SPACE POINT  
 THE CURRENT VALUE OF R IS .10000+07  
 THE CURRENT VALUE OF T IS .10000-01

DESIGN POINT COORDINATES (FEET)

XMIN	X	XMAX
.10000	.21999999	.40000
.00100	.02000000	.02000
.01000	.14999999	.20000
.50000	1.00000000	3.00000

SYSTEM WEIGHT= .13276+02 LBS/SQ-FT

FIACCO MC-CORMICK FUNCTION VALUE= .33567+14

BEHAVIOR CONSTRAINT INFORMATION

NUMBER	TYPE OF BEHAVIOR+UNITS	CRITICAL VALUE	LIMITING VALUE	TIME AT CRIT. VALUE	NORMALIZED VALUE
1	TEMP. AT ABL.-STR. INTERFACE (R)	.55052+03	.12000+04	900.00 SEC.	.54123-00
2	TEMP. AT RACK OF INSULATION (R)	.54001+03	.66000+03	900.00 SEC.	.18181-00
3	DISPLACEMENT AT PANEL CENTER (FT)	-.15886-01	.20000-01	847.34 SEC.	.20572-00
4	YIELD STRESS-STRUCTURE (KSI)	.12996+02 .36564+01	.45000+02	847.34 SEC.	.93346-00
5	YIELD STRESS-ABLATOR (KSI)	.71816-00 .72924-00	.11188+01 .39441+01	637.82 SEC.	.57513-00
7	TENSILE STRAIN-ABLATOR	.46501-02	.14793-01	651.42 SEC.	.08555-00
8	COMPRESSIVE STRAIN-ABLATOR	-.12909-01	.20000-00	85.50 SEC.	.93596-00

TOTAL ABLATED DISTANCE IS .05875 FT.

TEMPERATURE DISTRIBUTION AT 900.00 SECONDS

.2227+04	.2515+04	.2637+04	.2659+04	.2603+04	.2474+04	.2262+04	.1944+04	.1355+04	.1042+04
.8224+03	.6902+03	.6182+03	.5770+03	.5505+03	.5455+03	.5428+03	.5414+03	.5407+03	.5403+03
.5401+03	.5401+03	.5400+03	.5400+03	.5400+03					

Table 4.18 Case T3 Initial Point

DATA FOR THE CURRENT DESIGN SPACE POINT  
 THE CURRENT VALUE OF R IS .10000-05  
 THE CURRENT VALUE OF T IS .20000-02

DESIGN POINT COORDINATES (FEET)

XMIN	X	XMAX
.10000	.16551162	.40000
.00100	.00991283	.02000
.01000	.08952369	.20000
.50000	.56613301	3.00000

SYSTEM WEIGHT= .99749+01 LBS/SQ-FT  
 FIACCO MC-CORMICK FUNCTION VALUE= .99876+01

BEHAVIOR CONSTRAINT INFORMATION

NUMBER	TYPE OF BEHAVIOR, UNITS	CRITICAL VALUE	LIMITING VALUE	TIME AT CRIT. VALUE	NORMALIZED VALUE
1	TEMP. AT ABL.-STR. INTERFACE (R)	.98587+03	.12000+04	900.00 SEC.	.17844-00
2	TEMP. AT RACK OF INSULATION (R)	.56955+03	.66000+03	900.00 SEC.	.13704-00
3	DISPLACEMENT AT PANEL CENTER (FT)	-.19232-01	.20000-01	851.43 SEC.	.38402-01
4	YIELD STRESS-STRUCTURE (KSI)	.28188+02 .84323+01	.29184+02	851.43 SEC.	.26267-00
5	YIELD STRESS-ABLATOR (KSI)	.71717-00 .72479-00	.11179+01 .39323+01	349.35 SEC.	.57962-00
7	TENSILE STRAIN-ABLATOR	.46641-02	.14839-01	349.35 SEC.	.68568-00
8	COMPRESSIVE STRAIN-ABLATOR	-.65104-01	.10000+01	851.43 SEC.	.93490-00

TOTAL ABLATED DISTANCE IS .05873 FT.

TEMPERATURE DISTRIBUTION AT 900.00 SECONDS

.2202+04	.2431+04	.2567+04	.2642+04	.2673+04	.2668+04	.2632+04	.2567+04	.2471+04	.2342+04
.2181+04	.1981+04	.1718+04	.1294+04	.9859+03	.9240+03	.8560+03	.7774+03	.7053+03	.6544+03
.6192+03	.5956+03	.5805+03	.5722+03	.5696+03					

Table 4.18 (Concluded) Case T3 Final Point

DATA FOR THE CURRENT DESIGN SPACE POINT  
 THE CURRENT VALUE OF R IS .10000-01  
 THE CURRENT VALUE OF T IS .50000-02

DESIGN POINT COORDINATES (FEET)

XMIN	X	XMAX
.10000	.24999999	.40000
.00100	.00520000	.02000
.01000	.14999999	.20000
.50000	1.00000000	3.00000

SYSTEM WEIGHT= .11799+02 LBS/SQ-FT

FIACCO MC-CORMICK FUNCTION VALUE= .14344+03

BEHAVIOR CONSTRAINT INFORMATION

NUMBER	TYPE OF BEHAVIOR,UNITS	CRITICAL VALUE	LIMITING VALUE	TIME AT CRIT-VALUE	NORMALIZED VALUE
1	TEMP. AT ABL.-STR. INTERFACE (R)	.54374+03	.12000+04	900.00 SEC.	.54688-00
2	TEMP. AT BACK OF INSULATION (R)	.54000+03	.66000+03	900.00 SEC.	.18182-00
3	DISPLACEMENT AT PANEL CENTER (FT)	-.18481-01	.20000-01	845.20 SEC.	.75965-01
4	YIELD STRESS-STRUCTURE (KSI)	-.92362+01 -.19501+02	.45000+02	1.00 SEC.	.86481-00
5	YIELD STRESS-ABLATOR (KSI)	.71897-00 .69737-00	.11175+01 .39275+01	845.20 SEC.	.59813-00
7	TENSILE STRAIN-ABLATOR	.47642-02	.14863-01	845.20 SEC.	.67946-00
8	COMPRESSIVE STRAIN-ABLATOR	-.12688-01	.20000-00	107.37 SEC.	.93656-00

TOTAL ABLATED DISTANCE IS .05900 FT.

TEMPERATURE DISTRIBUTION AT 900.00 SECONDS

.2238+04	.2550+04	.2660+04	.2646+04	.2532+04	.2313+04	.1963+04	.1299+04	.9338+03	.7196+03
.6215+03	.5774+03	.5570+03	.5476+03	.5437+03	.5419+03	.5409+03	.5404+03	.5402+03	.5401+03
.5400+03	.5400+03	.5400+03	.5400+03	.5400+03					

Table 4.19 Case T4 Initial Point

DATA FOR THE CURRENT DESIGN SPACE POINT  
 THE CURRENT VALUE OF R IS .10000-05  
 THE CURRENT VALUE OF T IS .10000-02

DESIGN POINT COORDINATES (FEET)		
XMIN	X	XMAX
.10000	.21057887	.40000
.00100	.00150904	.02000
.01000	.07561053	.20000
.50000	.67359929	3.00000

SYSTEM WEIGHT= .97798+01 LBS/SQ-FT

FIACCO MC-CORMICK FUNCTION VALUE= .97920+01

BEHAVIOR CONSTRAINT INFORMATION

NUMBER	TYPE OF BEHAVIOR+UNITS	CRITICAL VALUE	LIMITING VALUE	TIME AT CRIT.VALUE	NORMALIZED VALUE
1	TEMP. AT ARL.-STR. INTERFACE (R)	.60370+03	.12000+04	900.00 SEC.	.49692-00
2	TEMP. AT RACK OF INSULATION (R)	.54457+03	.66000+03	900.00 SEC.	.17490-00
3	DISPLACEMENT AT PANEL CENTER (FT)	-.16522-01	.20000-01	849.11 SEC.	.17389-00
4	YIELD STRESS-STRUCTURE (KSI)	-.20602+02 -.35471+02	.45000+02	1.00 SEC.	.53497-00
5	YIELD STRESS-ABLATOR (KSI)	.63229-00 .62290-00	.11135+01 .38761+01	588.13 SEC.	.68230-00
7	TENSILE STRAIN-ABLATOR	.43674-02	.14700-01	140.26 SEC.	.70290-00
8	COMPRESSIVE STRAIN-ABLATOR	-.17873-01	.20000-00	849.11 SEC.	.91064-00

TOTAL ABLATED DISTANCE IS .05847 FT.

TEMPERATURE DISTRIBUTION AT 900.00 SECONDS

.2179+04	.2462+04	.2593+04	.2631+04	.2597+04	.2496+04	.2327+04	.2083+04	.1742+04	.1230+04
.9519+03	.7693+03	.6707+03	.6221+03	.6037+03	.5880+03	.5757+03	.5663+03	.5592+03	.5540+03
.5502+03	.5476+03	.5458+03	.5449+03	.5446+03					

Table 4.19 (Concluded) Case T4 Final Point



DATA FOR THE CURRENT DESIGN SPACE POINT  
 THE CURRENT VALUE OF R IS .10000-03  
 THE CURRENT VALUE OF T IS .10000-01

DESIGN POINT COORDINATES (FEET)  
 XMIN X XMAX  
 .10000 .23000000 .50000  
 .00167 .01200000 .05000  
 .01000 .14999999 .40000  
 .50000 1.19999999 3.00000

SYSTEM WEIGHT= .11333+02 LBS/SQ-FT  
 FIACCO MC-CORMICK FUNCTION VALUE= .15458+02

BEHAVIOR CONSTRAINT INFORMATION

NUMBER	TYPE OF BEHAVIOR, UNITS	CRITICAL VALUE	LIMITING VALUE	TIME AT CRIT. VALUE	NORMALIZED VALUE
1	TEMP. AT AHL.-STR. INTERFACE (R)	.95496+03	.12000+04	2400.00 SEC.	.20420-00
2	TEMP. AT RACK OF INSULATION (R)	.55242+03	.66000+03	2400.00 SEC.	.10299-00
3	DISPLACEMENT AT PANEL CENTER (FT)	-.19802-01	.20000-01	1048.03 SEC.	.98844-02
4	YIELD STRESS-STRUCTURE (KSI)	-.51516+01 -.10206+02	.16000+02	1.00 SEC.	.71843-00
5	YIELD STRESS-ABLATOR (KSI)	.91596-00 .91726-00	.11160+01 .39080+01	1220.42 SEC.	.32445-00
7	TENSILE STRAIN-ABLATOR	.60807-02	.14700-01	1.00 SEC.	.58835-00
8	COMPRESSIVE STRAIN-ABLATOR	-.12674-01	.20000-00	120.53 SEC.	.93863-00

TOTAL ABLATED DISTANCE IS .03968 FT.

TEMPERATURE DISTRIBUTION AT 2400.00 SECONDS  
 .1545+04 .1795+04 .1932+04 .2014+04 .2057+04 .2070+04 .2058+04 .2021+04 .1962+04 .1878+04  
 .1765+04 .1603+04 .1341+04 .1137+04 .9550+03 .8913+03 .8143+03 .7275+03 .6622+03 .6177+03  
 .5887+03 .5705+03 .5597+03 .5541+03 .5524+03

Table 4.20 Case T5 Initial Point

DATA FOR THE CURRENT DESIGN SPACE POINT  
 THE CURRENT VALUE OF R IS .10000-07  
 THE CURRENT VALUE OF T IS .20000-02

DESIGN POINT COORDINATES (FEET)  
 XMIN X XMAX  
 .10000 .21552230 .50000  
 .00167 .01154591 .05000  
 .01000 .14719679 .40000  
 .50000 .98000848 3.00000

SYSTEM WEIGHT= .10932+02 LBS/SQ-FT  
 FIACCO MC-CORMICK FUNCTION VALUE= .10933+02

BEHAVIOR CONSTRAINT INFORMATION

NUMBER	TYPE OF BEHAVIOR UNITS	CRITICAL VALUE	LIMITING VALUE	TIME AT CRIT. VALUE	NORMALIZED VALUE
1	TEMP. AT ARL.-STR. INTERFACE (R)	.11955+04	.12000+04	2400.00 SEC.	.37401-02
2	TEMP. AT RACK OF INSULATION (R)	.58316+03	.66000+03	2400.00 SEC.	.11642+00
3	DISPLACEMENT AT PANEL CENTER (FT)	-.13764-01	.20000-01	1127.05 SEC.	.31180-00
4	YIELD STRESS-STRUCTURE (KSI)	-.50806+01 -.10048+02	.16000+02	1.00 SEC.	.72813-00
5	YIELD STRESS-ABLATOR (KSI)	.91671-00 .91888-00	.11161+01 .39090+01	1092.11 SEC.	.32715-00
7	TENSILE STRAIN-ABLATOR	.60880-02	.14700-01	1.00 SEC.	.58575-00
8	COMPRESSIVE STRAIN-ABLATOR	-.46293-02	.73259-01	1.00 SEC.	.93681-00

TOTAL ABLATED DISTANCE IS .03981 FT.

TEMPERATURE DISTRIBUTION AT 2400.00 SECONDS  
 .1546+04 .1778+04 .1913+04 .1997+04 .2046+04 .2068+04 .2066+04 .2044+04 .2002+04 .1940+04  
 .1857+04 .1746+04 .1592+04 .1350+04 .1196+04 .1115+04 .1043+04 .9777+03 .9097+03 .8270+03  
 .7303+03 .6575+03 .6133+03 .5903+03 .5832+03

Table 4.20 (Concluded) Case T5 Final Point

DATA FOR THE CURRENT DESIGN SPACE POINT  
 THE CURRENT VALUE OF R IS .10000+05  
 THE CURRENT VALUE OF T IS .50000-02

DESIGN POINT COORDINATES (FEET)		
XMIN	X	XMAX
.10000	.21999999	.40000
.00100	.02000000	.04000
.03125	.05000000	.30000
.00100	.02000000	.04000
.01000	.14999999	.20000
.50000	1.00000000	3.00000

SYSTEM WEIGHT= .14520+02 LBS/SQ-FT

FIACCO MC-CORMICK FUNCTION VALUE= .12942+09

BEHAVIOR CONSTRAINT INFORMATION

NUMBER	TYPE OF BEHAVIOR, UNITS	CRITICAL VALUE	LIMITING VALUE	TIME AT CRIT. VALUE	NORMALIZED VALUE
1	TEMP. AT ABL.-STR. INTERFACE (R)	.55438+03	.12000+04	900.00 SEC.	.53802+00
2	TEMP. AT BACK OF INSULATION (R)	.54000+03	.66000+03	900.00 SEC.	.18142+00
3	DISPLACEMENT AT PANEL CENTER (FT)	-.48372-02	.20000-01	45.50 SEC.	.75814+00
4	YIELD STRESS-ABLATOR (KSI)	.95048-00 .98171-00	.11179+01 .39332+01	651.42 SEC.	.25262+00
5	YIELD STRESS-UPPER SAND. FACE (KSI)	-.75483+01 -.55360+01	.16000+02	5.30 SEC.	.90828+00
6	INTERCELL FACE BUCKLING STRESS (KSI)	-.79928-00	.89913+04	.00 SEC.	.10000+01
7	YIELD STRESS-LOWER SAND. FACE (KSI)	.42022+01 -.20109+01	.16000+02	5.30 SEC.	.88222+00
8	TENSILE STRAIN-ABLATOR	.61297-02	.14853-01	664.38 SEC.	.58732+00
9	COMPRESSIVE STRAIN-ABLATOR	-.11321-01	.20000-00	5.30 SEC.	.94339+00

TOTAL RELATED DISTANCE IS .05875 FT.

TEMPERATURE DISTRIBUTION AT 900.00 SECONDS

.2227+04	.2515+04	.2637+04	.2659+04	.2603+04	.2474+04	.2262+04	.1944+04	.1355+04	.1042+04
.8228+03	.6905+03	.6191+03	.5789+03	.5544+03	.5420+03	.5410+03	.5405+03	.5403+03	.5401+03
.5401+03	.5400+03	.5400+03	.5400+03	.5400+03	.5400+03				

Table 4.21 Case S1 Initial Point

DATA FOR THE CURRENT DESIGN SPACE POINT  
 THE CURRENT VALUE OF R IS .10000-07  
 THE CURRENT VALUE OF T IS .15000-01

DESIGN POINT COORDINATES (FEET)

XMIN	X	XMAX
.10000	.16697888	.40000
.00100	.00536281	.04000
.03125	.03137343	.30000
.00100	.00536281	.04000
.01000	.06082772	.20000
.50000	1.06361239	3.00000

SYSTEM WEIGHT= .86845+01 LBS/SQ-FT

FIACCO MC-CORMICK FUNCTION VALUE= .86846+01

BEHAVIOR CONSTRAINT INFORMATION

NUMBER	TYPE OF BEHAVIOR, UNITS	CRITICAL VALUE	LIMITING VALUE	TIME AT CRIT. VALUE	NORMALIZED VALUE
1	TEMP. AT ARL.-STR. INTERFACE (R)	.11090+04	.12000+04	900.00 SEC.	.70833-01
1	TEMP. AT RACK OF INSULATION (R)	.63014+03	.66000+03	900.00 SEC.	.45244-01
3	DISPLACEMENT AT PANEL CENTER (FT)	-.19091-01	.20000-01	844.92 SEC.	.45429-01
4	YIELD STRESS-ARLATOR (KSI)	.88819-00 .92816-00	.11151+01 .38958+01	355.88 SEC.	.33569-00
5	YIELD STRESS-UPPER SAND. FACE (KSI)	-.73995+01 -.95754+01	.16000+02	1.00 SEC.	.73709-00
6	INTERCELL FACE BUCKLING STRESS (KSI)	-.12430+01	.49151+03	844.92 SEC.	.98481-00
7	YIELD STRESS-LOWER SAND. FACE (KSI)	.98837+01 .40588+01	.14911+02	844.92 SEC.	.66696-00
8	TENSILE STRAIN-ARLATOR	.57511-02	.15021-01	355.88 SEC.	.61714-00
9	COMPRESSIVE STRAIN-ARLATOR	-.12819-01	.20000-00	15.74 SEC.	.93591-00

TOTAL ARLATED DISTANCE IS .05856 FT.

TEMPERATURE DISTRIBUTION AT 900.00 SECONDS

.2191+04	.2422+04	.2560+04	.2637+04	.2669+04	.2665+04	.2629+04	.2562+04	.2464+04	.2333+04
.2170+04	.1968+04	.1703+04	.1288+04	.1109+04	.8619+03	.8255+03	.7849+03	.7463+03	.7141+03
.6877+03	.6666+03	.6505+03	.6391+03	.6324+03	.6301+03				

Table 4.21 (Concluded) Case S1 Final Point

DATA FOR THE CURRENT DESIGN SPACE POINT  
 THE CURRENT VALUE OF R IS .10000+05  
 THE CURRENT VALUE OF T IS .50000-02

DESIGN POINT COORDINATES (FEET)		
XMIN	X	XMAX
.10000	.21999999	.40000
.00100	.02000000	.04000
.03125	.05000000	.30000
.00100	.02000000	.04000
.01000	.14999999	.20000
.50000	1.00000000	3.00000

SYSTEM WEIGHT= .14520+02 LBS/50-FT

FIACCO MC-CORMICK FUNCTION VALUE= .12942+09

BEHAVIOR CONSTRAINT INFORMATION

NUMBER	TYPE OF BEHAVIOR, UNITS	CRITICAL VALUE	LIMITING VALUE	TIME AT CRIT. VALUE	NORMALIZED VALUE
1	TEMP. AT ABL.-STR. INTERFACE (R)	.55438+03	.12000+04	900.00 SEC.	.53802-00
2	TEMP. AT BACK OF INSULATION (R)	.54000+03	.66000+03	900.00 SEC.	.18182-00
3	DISPLACEMENT AT PANEL CENTER (FT)	-.48372-02	.20000-01	85.50 SEC.	.75814-00
4	YIELD STRESS-ABLATOR (KSI)	.95048-00 .98171-00	.11179+01 .39332+01	651.42 SEC.	.25262-00
5	YIELD STRESS-UPPER SAND. FACE (KSI)	-.75483+01 -.55360+01	.16000+02	5.30 SEC.	.90828-00
6	INTERCELL FACE BUCKLING STRESS (KSI)	-.79928-00	.88913+04	.00 SEC.	.10000+01
7	YIELD STRESS-LOWER SAND. FACE (KSI)	.42022+01 -.20109+01	.16000+02	5.30 SEC.	.88222-00
8	TENSILE STRAIN-ABLATOR	.61297-02	.14853-01	664.38 SEC.	.58732-00
9	COMPRESSIVE STRAIN-ABLATOR	-.11321-01	.20000-00	5.30 SEC.	.94339-00

TOTAL ABLATED DISTANCE IS .05875 FT.

TEMPERATURE DISTRIBUTION AT 900.00 SECONDS

.2227+04	.2515+04	.2637+04	.2659+04	.2603+04	.2474+04	.2262+04	.1944+04	.1355+04	.1042+04
.8228+03	.6905+03	.6191+03	.5789+03	.5544+03	.5420+03	.5410+03	.5405+03	.5403+03	.5401+03
.5401+03	.5400+03	.5400+03	.5400+03	.5400+03	.5400+03				

Table 4.22 Case S2 Initial Point

DATA FOR THE CURRENT DESIGN SPACE POINT  
 THE CURRENT VALUE OF R IS .10000-07  
 THE CURRENT VALUE OF T IS .26500-01

DESIGN POINT COORDINATES (FEET)		
XMIN	X	XMAX
.10000	.16449440	.40000
.00100	.00625174	.04000
.03125	.03253096	.30000
.00100	.00438000	.04000
.01000	.06000000	.20000
.50000	1.05322459	3.00000

SYSTEM WEIGHT= .85959+01 LBS/SQ-FT  
 FIACCO MC-CORMICK FUNCTION VALUE= .85961+01

BEHAVIOR CONSTRAINT INFORMATION

NUMBER	TYPE OF BEHAVIOR, UNITS	CRITICAL VALUE	LIMITING VALUE	TIME AT CRIT. VALUE	NORMALIZED VALUE
1	TEMP. AT ARL.-STR. INTERFACE (R)	.11874+04	.12000+04	900.00 SEC.	.10442-01
2	TEMP. AT RACK OF INSULATION (R)	.65275+03	.66000+03	900.00 SEC.	.10979-01
3	DISPLACEMENT AT PANEL CENTER (FT)	-.18697-01	.20000-01	847.12 SEC.	.65164-01
4	YIELD STRESS-ARLATOR (KSI)	.90333-00 .93611-00	.11155+01 .39016+01	349.91 SEC.	.31958-00
5	YIELD STRESS-UPPER SAND. FACE (KSI)	-.71113+01 -.94556+01	.16000+02	1.00 SEC.	.75139-00
6	INTERCELL FACE BUCKLING STRESS (KSI)	-.10165+01	.60256+03	867.86 SEC.	.99178-00
7	YIELD STRESS-LOWER SAND. FACE (KSI)	.11088+02 .45983+01	.14819+02	847.12 SEC.	.57610-00
8	TENSILE STRAIN-ARLATOR	.58614-02	.14992-01	349.91 SEC.	.80903-00
9	COMPRESSIVE STRAIN-ARLATOR	-.12722-01	.20000-00	59.92 SEC.	.93639-00

TOTAL ARLATED DISTANCE IS .05881 FT.

TEMPERATURE DISTRIBUTION AT 900.00 SECONDS									
.2211+04	.2439+04	.2575+04	.2650+04	.2682+04	.2680+04	.2647+04	.2585+04	.2495+04	.2374+04
.2211+04	.2032+04	.1788+04	.1391+04	.1187+04	.9120+03	.8780+03	.8415+03	.8002+03	.7586+03
.7277+03	.6981+03	.6780+03	.6639+03	.6555+03	.6528+03				

Table 4.22 (Concluded) Case S2, Final Point

50

DATA FOR THE CURRENT DESIGN SPACE POINT  
 THE CURRENT VALUE OF R IS .10000+05  
 THE CURRENT VALUE OF T IS .20000-01

DESIGN POINT COORDINATES (FEET)		
XMIN	X	XMAX
.10000	.24999999	.40000
.00100	.03000000	.04000
.03125	.24999999	.30000
.00100	.03000000	.04000
.01000	.10000000	.20000
.50000	2.00000000	3.00000

SYSTEM WEIGHT= .18200+02 LBS/SQ-FT

FIACCO MC-CORMICK FUNCTION VALUE= .13376+09

BEHAVIOR CONSTRAINT INFORMATION

NUMBER	TYPE OF BEHAVIOR, UNITS	CRITICAL VALUE	LIMITING VALUE	TIME AT CRIT. VALUE	NORMALIZED VALUE
1	TEMP. AT AQL.-STR. INTERFACE (R)	.54154+03	.12000+04	900.00 SEC.	.54872-00
2	TEMP. AT BACK OF INSULATION (R)	.54000+03	.66000+03	1.00 SEC.	.18182-00
3	DISPLACEMENT AT PANEL CENTER (FT)	-.49694-02	.20000-01	1.00 SEC.	.75153-00
4	YIELD STRESS-ARLATOR (KSI)	.97074-00 .99342-00	.11185+01 .39400+01	900.00 SEC.	.22870-00
5	YIELD STRESS-UPPER SAND. FACE (KSI)	-.80226+01 -.50806+01	.16000+02	1.00 SEC.	.85143-00
6	INTERCELL FACE BUCKLING STRESS (KSI)	-.15383+01	.20086+05	.00 SEC.	.10000+01
7	YIELD STRESS-LOWER SAND. FACE (KSI)	.28843+01 -.18085+01	.16000+02	1.00 SEC.	.95435-00
8	TENSILE STRAIN-ARLATOR	.62644-02	.14800-01	900.00 SEC.	.57672-00
9	COMPRESSIVE STRAIN-ARLATOR	-.58023-02	.20000-00	5.30 SEC.	.97099-00

TOTAL ARLATED DISTANCE IS .05902 FT.

TEMPERATURE DISTRIBUTION AT 900.00 SECONDS

.2234+04	.2548+04	.2660+04	.2648+04	.2534+04	.2315+04	.1963+04	.1299+04	.9304+03	.7173+03
.6205+03	.5769+03	.5564+03	.5467+03	.5415+03	.5400+03	.5400+03	.5400+03	.5400+03	.5400+03
.5400+03	.5400+03	.5400+03	.5400+03	.5400+03	.5400+03				

Table 4.23 Case S3 Initial Design Point

DATA FOR THE CURRENT DESIGN SPACE POINT  
 THE CURRENT VALUE OF R IS .10000+05  
 THE CURRENT VALUE OF T IS .20000-01

DESIGN POINT COORDINATES (FEET)

XMIN	X	XMAX
.10000	.32601875	.40000
.00100	.03193425	.04000
.03125	.08442883	.30000
.00100	.03193425	.04000
.01000	.09524744	.20000
.50000	1.73327190	3.00000

SYSTEM WEIGHT= .20417+02 LBS/SQ-FT

FIACCO MC-CORMICK FUNCTION VALUE= .13357+09

BEHAVIOR CONSTRAINT INFORMATION

NUMBER	TYPE OF BEHAVIOR, UNITS	CRITICAL VALUE	LIMITING VALUE	TIME AT CRIT. VALUE	NORMALIZED VALUE
1	TEMP. AT ARL.-STR. INTERFACE (R)	.54000+03	.12000+04	900.00 SEC.	.55000-00
2	TEMP. AT BACK OF INSULATION (R)	.54000+03	.66000+03	1.00 SEC.	.18182-00
3	DISPLACEMENT AT PANEL CENTER (FT)	-.89304-02	.20000-01	41.94 SEC.	.55348-00
4	YIELD STRESS-ARLATOR (KSI)	.87026-00 .94458-00	.11200+01 .39599+01	900.00 SEC.	.34027-00
5	YIELD STRESS-UPPER SAND. FACE (KSI)	-.75895+01 -.54847+01	.16000+02	1.00 SEC.	.90619-00
6	INTERCELL FACE BUCKLING STRESS (KSI)	-.41800+01	.22770+05	.00 SEC.	.10000+01
7	YIELD STRESS-LOWER SAND. FACE (KSI)	.43401+01 -.17740+01	.16000+02	6.77 SEC.	.88405-00
8	TENSILE STRAIN-ARLATOR	.54342-02	.14700-01	900.00 SEC.	.03033-00
9	COMPRESSIVE STRAIN-ARLATOR	-.10786-01	.20000-00	6.77 SEC.	.94607-00

TOTAL ARLATED DISTANCE IS .05889 FT.

TEMPERATURE DISTRIBUTION AT 900.00 SECONDS

.2262+04	.2599+04	.2628+04	.2453+04	.2061+04	.1258+04	.7796+03	.6118+03	.5633+03	.5476+03
.5423+03	.5407+03	.5402+03	.5400+03	.5400+03	.5400+03	.5400+03	.5400+03	.5400+03	.5400+03
.5400+03	.5400+03	.5400+03	.5400+03	.5400+03	.5400+03				

Table 4.23 (Continued) Case 53 Design Point at end of first cycle



DATA FOR THE CURRENT DESIGN SPACE POINT  
 THE CURRENT VALUE OF R IS .10000+03  
 THE CURRENT VALUE OF T IS .15000-01

DESIGN POINT COORDINATES (FEET)		
XMIN	X	XMAX
.10000	.35037106	.40000
.00100	.02948921	.04000
.03125	.05522791	.30000
.00100	.02948921	.04000
.01000	.09436294	.20000
.50000	1.30591150	3.00000

SYSTEM WEIGHT= .20764+02 LBS/SQ-FT

FIACCO MC=CORMICK FUNCTION VALUE= .13083+07

BEHAVIOR CONSTRAINT INFORMATION

NUMBER	TYPE OF BEHAVIOR+UNITS	CRITICAL VALUE	LIMITING VALUE	TIME AT CRIT.VALUE	NORMALIZED VALUE
1	TEMP. AT ARL.-STR. INTERFACE (R)	.54000+03	.12000+04	1.00 SEC.	.55000-00
2	TEMP. AT RACK OF INSULATION (R)	.54000+03	.66000+03	1.00 SEC.	.18182-00
3	DISPLACEMENT AT PANEL CENTER (FT)	-.61768-02	.20000-01	130.67 SEC.	.69116-00
4	YIELD STRESS-ARLATOR (KSI)	.84651-00	.11200+01	900.00 SEC.	.37099-00
		.92486-00	.39600+01		
5	YIELD STRESS-UPPER SAND. FACE (KSI)	-.67164+01	.16000+02	1.00 SEC.	.92008-00
		-.56650+01			
6	INTERCELL FACE BUCKLING STRESS (KSI)	-.45734+01	.19417+05	.00 SEC.	.10000+01
7	YIELD STRESS-LOWER SAND. FACE (KSI)	.43634+01	.16000+02	93.10 SEC.	.88467-00
		-.17229+01			
8	TENSILE STRAIN-ARLATOR	.52690-02	.14700-01	900.00 SEC.	.84157-00
9	COMPRESSIVE STRAIN-ARLATOR	-.12275-01	.20000-00	6.77 SEC.	.93863-00

TOTAL ABLATED DISTANCE IS .05864 FT.

TEMPERATURE DISTRIBUTION AT 900.00 SECONDS									
.2240+04	.2557+04	.2511+04	.2168+04	.1266+04	.8133+03	.6305+03	.5701+03	.5494+03	.5427+03
.5407+03	.5402+03	.5400+03	.5400+03	.5400+03	.5400+03	.5400+03	.5400+03	.5400+03	.5400+03
.5400+03	.5400+03	.5400+03	.5400+03	.5400+03	.5400+03				

Table 4.23 (Continued) Case S3 Design Point at end of second cycle

DATA FOR THE CURRENT DESIGN SPACE POINT  
 THE CURRENT VALUE OF R IS .10000+01  
 THE CURRENT VALUE OF T IS .10000-01

DESIGN POINT COORDINATES (FEET)		
XMIN	X	XMAX
.10000	.36656050	.40000
.00100	.02542638	.04000
.03125	.04000790	.30000
.00100	.02542638	.04000
.01000	.09332451	.20000
.50000	.95703433	3.00000

SYSTEM WEIGHT= .20635+02 LBS/SQ-FT

FIACCO MC-CORMICK FUNCTION VALUE= .12912+05

BEHAVIOR CONSTRAINT INFORMATION

NUMBER	TYPE OF BEHAVIOR, UNITS	CRITICAL VALUE	LIMITING VALUE	TIME AT CRIT. VALUE	NORMALIZED VALUE
1	TEMP. AT ABL.-STR. INTERFACE (R)	.54000+03	.12000+04	1.00 SEC.	.55000-00
1	TEMP. AT BACK OF INSULATION (R)	.54000+03	.66000+03	1.00 SEC.	.18182-00
3	DISPLACEMENT AT PANEL CENTER (FT)	-.37408-02	.20000-01	302.63 SEC.	.81296-00
4	YIELD STRESS-ABLATOR (KSI)	.83668-00 .90698-00	.11200+01 .39600+01	900.00 SEC.	.39111-00
5	YIELD STRESS-UPPER SAND. FACE (KSI)	-.59986+01 -.60778+01	.16000+02	1.00 SEC.	.91268-00
6	INTERCELL FACE BUCKLING STRESS (KSI)	-.47095+01	.14435+05	.00 SEC.	.10000+01
7	YIELD STRESS-LOWER SAND. FACE (KSI)	.29056+01 -.32907+01	.16000+02	6.77 SEC.	.88737-00
8	TENSILE STRAIN-ABLATOR	.54331-02	.14700-01	1.00 SEC.	.63040-00
9	COMPRESSIVE STRAIN-ABLATOR	-.13050-01	.20000-00	6.77 SEC.	.93475-00

TOTAL ABLATED DISTANCE IS .05869 FT.

TEMPERATURE DISTRIBUTION AT 900.00 SECONDS

.2253+04	.2580+04	.2527+04	.2170+04	.1259+04	.7620+03	.6028+03	.5586+03	.5453+03	.5414+03
.5403+03	.5401+03	.5400+03	.5400+03	.5400+03	.5400+03	.5400+03	.5400+03	.5400+03	.5400+03
.5400+03	.5400+03	.5400+03	.5400+03	.5400+03	.5400+03				

Table 4.23 (Continued) Case S3 Design Point at end of third cycle

DATA FOR THE CURRENT DESIGN SPACE POINT  
 THE CURRENT VALUE OF R IS .10000-01  
 THE CURRENT VALUE OF T IS .80000-02

DESIGN POINT COORDINATES (FEET)		
XMIN	X	XMAX
.10000	.22756072	.40000
.00100	.00820324	.04000
.03125	.07107190	.30000
.00100	.00820324	.04000
.01000	.05719849	.20000
.50000	.92189198	3.00000

SYSTEM WEIGHT= .11851+02 LBS/SQ-FT

FIACCO MC-CORMICK FUNCTION VALUE= .14071+03

BEHAVIOR CONSTRAINT INFORMATION

NUMBER	TYPE OF BEHAVIOR, UNITS	CRITICAL VALUE	LIMITING VALUE	TIME AT CRIT. VALUE	NORMALIZED VALUE
1	TEMP. AT AHL.-STR. INTERFACE (R)	.55585+03	.12000+04	900.00 SEC.	.53680-00
2	TEMP. AT BACK OF INSULATION (R)	.54043+03	.66000+03	900.00 SEC.	.18117-00
3	DISPLACEMENT AT PANEL CENTER (FT)	-.47883-02	.20000-01	155.88 SEC.	./6058-00
4	YIELD STRESS-ABLATOR (KSI)	.88144-00 .92557-00	.11164+01 .39129+01	703.38 SEC.	.54383-00
5	YIELD STRESS-UPPER SAND. FACE (KSI)	-.90024+01 -.94840+01	.16000+02	5.30 SEC.	.71204-00
6	INTERCELL FACE BUCKLING STRESS (KSI)	-.22320+01	.14951+04	.00 SEC.	.10000+01
7	YIELD STRESS-LOWER SAND. FACE (KSI)	.29152+01 -.59087+01	.16000+02	5.30 SEC.	./6314-00
8	TENSILE STRAIN-ABLATOR	.56751-02	.14954-01	710.84 SEC.	.82049-00
9	COMPRESSIVE STRAIN-ABLATOR	-.12051-01	.20000-00	5.30 SEC.	.93974-00

TOTAL ABLATED DISTANCE IS .05893 FT.

TEMPERATURE DISTRIBUTION AT 900.00 SECONDS

.2224+04	.2522+04	.2649+04	.2670+04	.2610+04	.2474+04	.2253+04	.1924+04	.1321+04	.9853+03
.7660+03	.6522+03	.5967+03	.5691+03	.5559+03	.5431+03	.5424+03	.5419+03	.5415+03	.5411+03
.5409+03	.5407+03	.5406+03	.5405+03	.5404+03	.5404+03				

Table 4.23 (Continued) Case S3 Design Point at end of fourth cycle

DATA FOR THE CURRENT DESIGN SPACE POINT  
 THE CURRENT VALUE OF R IS .10000-03  
 THE CURRENT VALUE OF T IS .60000-02

DESIGN POINT COORDINATES (FEET)		
XMIN	X	XMAX
.10000	.17242090	.40000
.00100	.00470954	.04000
.03125	.05442570	.30000
.00100	.00470954	.04000
.01000	.04307401	.20000
.50000	1.25418130	3.00000

SYSTEM WEIGHT= .86256+01 LBS/50-FT

FIACCO MC-CORMICK FUNCTION VALUE= .10120+02

BEHAVIOR CONSTRAINT INFORMATION

NUMBER	TYPE OF BEHAVIOR, UNITS	CRITICAL VALUE	LIMITING VALUE	TIME AT CRIT. VALUE	NORMALIZED VALUE
1	TEMP. AT ABL.-STR. INTERFACE (R)	.10000+04	.12000+04	900.00 SEC.	.16665-00
2	TEMP. AT BACK OF INSULATION (R)	.64215+03	.66000+03	900.00 SEC.	.27045-01
3	DISPLACEMENT AT PANEL CENTER (FT)	-.16054-01	.20000-01	847.17 SEC.	.19728-00
4	YIELD STRESS-ABLATOR (KSI)	.86679-00 .91337-00	.11157+01 .39039+01	370.27 SEC.	.36222-00
5	YIELD STRESS-UPPER SAND. FACE (KSI)	-.94083+01 -.10912+02	.16000+02	5.30 SEC.	.62688-00
6	INTERCELL FACE BUCKLING STRESS (KSI)	-.12213+01	.43063+03	857.47 SEC.	.98425-00
7	YIELD STRESS-LOWER SAND. FACE (KSI)	.92075+01 .39640+01	.13288+02	847.17 SEC.	.63759-00
8	TENSILE STRAIN-ABLATOR	.56559-02	.15126-01	386.59 SEC.	.62607-00
9	COMPRESSIVE STRAIN-ABLATOR	-.12165-01	.20000-00	5.30 SEC.	.93917-00

TOTAL ABLATED DISTANCE IS .05874 FT.

TEMPERATURE DISTRIBUTION AT 900.00 SECONDS									
.2206+04	.2444+04	.2579+04	.2650+04	.2673+04	.2658+04	.2608+04	.2525+04	.2406+04	.2251+04
.2055+04	.1796+04	.1369+04	.1143+04	.1000+04	.7598+03	.7372+03	.7171+03	.6994+03	.6841+03
.6713+03	.6608+03	.6526+03	.6468+03	.6433+03	.6422+03				

Table 4.23 (Continued) Case S3 Design Point at end of fifth cycle

DATA FOR THE CURRENT DESIGN SPACE POINT  
 THE CURRENT VALUE OF R IS .10000-05  
 THE CURRENT VALUE OF T IS .20000-02

DESIGN POINT COORDINATES (FEET)

XMIN	X	XMAX
.10000	.17156886	.40000
.00100	.00439568	.04000
.03125	.05359476	.30000
.00100	.00439568	.04000
.01000	.05000000	.20000
.50000	1.26208939	3.00000

SYSTEM WEIGHT= .85574+01 LBS/SQ-FT

FIACCO MC-CORMICK FUNCTION VALUE= .85722+01

BEHAVIOR CONSTRAINT INFORMATION

NUMBER	TYPE OF BEHAVIOR, UNITS	CRITICAL VALUE	LIMITING VALUE	TIME AT CRIT. VALUE	NORMALIZED VALUE
1	TEMP. AT ARL.-STR. INTERFACE (R)	.10428+04	.12000+04	900.00 SEC.	.13101-00
1	TEMP. AT BACK OF INSULATION (R)	.63141+03	.66000+03	900.00 SEC.	.43315-01
3	DISPLACEMENT AT PANEL CENTER (FT)	-.17674-01	.20000-01	850.66 SEC.	.11632+00
4	YIELD STRESS-ABLATOR (KSI)	.86245-00 .90791-00	.11150+01 .38954+01	369.84 SEC.	.36833-00
5	YIELD STRESS-UPPER SAND. FACE (KSI)	-.94759+01 -.11257+02	.16000+02	5.30 SEC.	.60563-00
6	INTERCELL FACB BUCKLING STRESS (KSI)	-.13509+01	.35751+03	868.49 SEC.	.98010-00
7	YIELD STRESS-LOWER SAND. FACE (KSI)	.98354+01 .42003+01	.13618+02	842.95 SEC.	.60603-00
8	TENSILE STRAIN-ABLATOR	.56481-02	.15200-01	386.95 SEC.	.02841-00
9	COMPRESSIVE STRAIN-ABLATOR	-.12199-01	.20000-00	15.85 SEC.	.93900-00

TOTAL ARLATED DISTANCE IS .05881 FT.

TEMPERATURE DISTRIBUTION AT 900.00 SECONDS

.2204+04	.2442+04	.2580+04	.2652+04	.2678+04	.2665+04	.2619+04	.2539+04	.2424+04	.2273+04
.2084+04	.1842+04	.1477+04	.1193+04	.1043+04	.7862+03	.7559+03	.7292+03	.7059+03	.6859+03
.6691+03	.6555+03	.6449+03	.6374+03	.6329+03	.6314+03				

Table 4.23 (Concluded) Case S3 Design Point at end of sixth cycle (Final Design Point)

DATA FOR THE CURRENT DESIGN SPACE POINT  
 THE CURRENT VALUE OF R IS .10000+01  
 THE CURRENT VALUE OF T IS .10000-01

DESIGN POINT COORDINATES (FEET)

XMIN	X	XMAX
.10000	.24999999	.40000
.00100	.03000000	.04000
.03125	.24999999	.30000
.00100	.03000000	.04000
.01000	.10000000	.20000
.50000	2.00000000	3.00000

SYSTEM THICKNESS= .66000-00 FT.

FIACCO MC-CORMICK FUNCTION VALUE= .13376+05

BEHAVIOR CONSTRAINT INFORMATION

NUMBER	TYPE OF BEHAVIOR, UNITS	CRITICAL VALUE	LIMITING VALUE	TIME AT CRIT. VALUE	NORMALIZED VALUE
1	TEMP. AT ABL.-STR. INTERFACE (R)	.54154+03	.12000+04	900.00 SEC.	.54872-00
1	TEMP. AT BACK OF INSULATION (R)	.54000+03	.66000+03	1.00 SEC.	.18182-00
3	DISPLACEMENT AT PANEL CENTER (FT)	-.49694-02	.20000-01	1.00 SEC.	./5153-00
4	YIELD STRESS-ABLATOR (KSI)	.97074-00 .99342-00	.11185+01 .39400+01	900.00 SEC.	.22870-00
5	YIELD STRESS-UPPER SAND. FACE (KSI)	-.80226+01 -.50806+01	.16000+02	1.00 SEC.	.85143-00
6	INTERCELL FACE BUCKLING STRESS (KSI)	-.15383+01	.20086+05	.00 SEC.	.10000+01
7	YIELD STRESS-LOWER SAND. FACE (KSI)	.28843+01 -.18085+01	.16000+02	1.00 SEC.	.93435-00
8	TENSILE STRAIN-ABLATOR	.62644-02	.14800-01	900.00 SEC.	.57672-00
9	COMPRESSIVE STRAIN-ABLATOR	-.58023-02	.20000-00	5.30 SEC.	.97099-00

TOTAL ABLATED DISTANCE IS .05902 FT.

TEMPERATURE DISTRIBUTION AT 900.00 SECONDS

.2234+04	.2548+04	.2660+04	.2648+04	.2534+04	.2315+04	.1963+04	.1299+04	.9304+03	.7173+03
.6205+03	.5769+03	.5564+03	.5467+03	.5415+03	.5400+03	.5400+03	.5400+03	.5400+03	.5400+03
.5400+03	.5400+03	.5400+03	.5400+03	.5400+03	.5400+03				

Table 4.24 Case S4 Initial Point

DATA FOR THE CURRENT DESIGN SPACE POINT  
 THE CURRENT VALUE OF R IS .10000-07  
 THE CURRENT VALUE OF T IS .10000-02

DESIGN POINT COORDINATES (FEET)

XMIN	X	XMAX
.10000	.16773245	.40000
.00100	.01300506	.04000
.03125	.03625361	.30000
.00100	.01300506	.04000
.01000	.02600000	.20000
.50000	.56138000	3.00000

SYSTEM THICKNESS= .25600-00 FT.

FIACCO MC-CORMICK FUNCTION VALUE= .25615-00

BEHAVIOR CONSTRAINT INFORMATION

NUMBER	TYPE OF BEHAVIOR, UNITS	CRITICAL VALUE	LIMITING VALUE	TIME AT CRIT. VALUE	NORMALIZED VALUE
1	TEMP. AT ABL.-STR. INTERFACE (R)	.93752+03	.12000+04	900.00 SEC.	.21873-00
1	TEMP. AT RACK OF INSULATION (R)	.65225+03	.66000+03	900.00 SEC.	.11742-01
3	DISPLACEMENT AT PANEL CENTER (FT)	-.21306-02	.20000-01	56.50 SEC.	.89347-00
4	YIELD STRESS-ABLATOR (KSI)	.95429-00 .98414-00	.11181+01 .39351+01	347.49 SEC.	.24803-00
5	YIELD STRESS-UPPER SAND. FACE (KSI)	-.74434+01 -.59714+01	.16000+02	5.30 SEC.	.89556-00
6	INTERCELL FACE BUCKLING STRESS (KSI)	-.15390-00	.33204+04	884.62 SEC.	.99989-00
7	YIELD STRESS-LOWER SAND. FACE (KSI)	.38861+01 -.25725+01	.16000+02	5.30 SEC.	.87611-00
8	TENSILE STRAIN-ABLATOR	.61820-02	.14884-01	360.18 SEC.	.58466-00
9	COMPRESSIVE STRAIN-ABLATOR	-.11753-01	.20000-00	5.30 SEC.	.94124-00

TOTAL ABLATED DISTANCE IS .05805 FT.

TEMPERATURE DISTRIBUTION AT 900.00 SECONDS

.2195+04	.2418+04	.2558+04	.2636+04	.2669+04	.2665+04	.2629+04	.2563+04	.2465+04	.2334+04
.2170+04	.1967+04	.1698+04	.1269+04	.9375+03	.6936+03	.6858+03	.6788+03	.6726+03	.6673+03
.6627+03	.6589+03	.6560+03	.6539+03	.6527+03	.6523+03				

Table 4.24 (Concluded) Case S4 Final Point

DATA FOR THE CURRENT DESIGN SPACE POINT  
 THE CURRENT VALUE OF R IS .10000-03  
 THE CURRENT VALUE OF T IS .50000-02

DESIGN POINT COORDINATES (FEET)		
XMIN	X	XMAX
.10000	.23000000	.40000
.00100	.00300000	.04000
.03125	.05000000	.30000
.00100	.00300000	.04000
.01000	.12000000	.20000
.50000	1.69999999	3.00000

SYSTEM WEIGHT= .10548+02 LBS/SQ-FT

FIACCO MC-CORMICK FUNCTION VALUE= .14700+02

BEHAVIOR CONSTRAINT INFORMATION

NUMBER	TYPE OF BEHAVIOR,UNITS	CRITICAL VALUE	LIMITING VALUE	TIME AT CRIT.VALUE	NORMALIZED VALUE
1	TEMP. AT ABL.-STR. INTERFACE (R)	.11132+04	.12000+04	2400.00 SEC.	.72332-01
1	TEMP. AT BACK OF INSULATION (R)	.58558+03	.66000+03	2400.00 SEC.	.11276+00
3	DISPLACEMENT AT PANEL CENTER (FT)	-.18116-01	.20000-01	867.58 SEC.	.94214-01
4	YIELD STRESS-ABLATOR (KSI)	.78063-00 .81348-00	.11132+01 .38714+01	1208.75 SEC.	.48667-00
5	YIELD STRESS-UPPER SAND. FACE (KSI)	-.10158+02 -.15410+02	.16000+02	1.00 SEC.	.29777-00
6	INTERCELL FACE HUCKLING STRESS (KSI)	-.16650-00	.15300+03	2138.00 SEC.	.99691-00
7	YIELD STRESS-LOWER SAND. FACE (KSI)	-.26460+01 -.13156+02	.16000+02	1.00 SEC.	.45252-00
8	TENSILE STRAIN-ABLATOR	.50108-02	.14700-01	1.00 SEC.	.65913-00
9	COMPRFSSIVE STRAIN-ABLATOR	-.11712-01	.20000-00	120.53 SEC.	.94144-00

TOTAL ABLATED DISTANCE IS .03968 FT.

TEMPERATURE DISTRIBUTION AT 2400.00 SECONDS

.1553+04	.1794+04	.1931+04	.2013+04	.2057+04	.2070+04	.2058+04	.2022+04	.1963+04	.1881+04
.1769+04	.1612+04	.1362+04	.1199+04	.1113+04	.9379+03	.8929+03	.8415+03	.7804+03	.7206+03
.6741+03	.6393+03	.6145+03	.5980+03	.5886+03	.5856+03				

Table 4.25 Case 55 Initial Point



DATA FOR THE CURRENT DESIGN SPACE POINT  
 THE CURRENT VALUE OF R IS .10000-05  
 THE CURRENT VALUE OF T IS .30000-02

DESIGN POINT COORDINATES (FEET)		
XMIN	X	XMAX
.10000	.22291974	.40000
.00100	.00260099	.04000
.03125	.05174608	.30000
.00100	.00260099	.04000
.01000	.11860985	.20000
.50000	1.64502479	3.00000

SYSTEM WEIGHT= .10227+02 LBS/SQ-FT

FIACCO MC-CORMICK FUNCTION VALUE= .10273+02

BEHAVIOR CONSTRAINT INFORMATION

NUMBER	TYPE OF BEHAVIOR,UNITS	CRITICAL VALUE	LIMITING VALUE	TIME AT CRIT.VALUE	NORMALIZED VALUE
1	TEMP. AT ABL.-STR. INTERFACE (R)	.11874+04	.12000+04	2400.00 SEC.	.10512-01
1	TEMP. AT BACK OF INSULATION (R)	.61658+03	.66000+03	2400.00 SEC.	.65793-01
3	DISPLACEMENT AT PANEL CENTER (FT)	-.17326-01	.20000-01	668.71 SEC.	.13368-00
4	YIELD STRESS-ABLATOR (KSI)	.76747-00 .79838-00	.11126+01 .38634+01	1153.27 SEC.	.50421-00
5	YIELD STRESS-UPPER SAND. FACE (KSI)	-.10744+02 -.16171+02	.16000+02	1.00 SEC.	.22205-00
6	INTERCELL FACE BUCKLING STRESS (KSI)	-.17501-00	.10430+03	2018.97 SEC.	.99508-00
7	YIELD STRESS-LOWER SAND. FACE (KSI)	-.30680+01 -.13808+02	.16000+02	1.00 SEC.	.37813-00
8	TENSILE STRAIN-ABLATOR	.48998-02	.14700-01	1.00 SEC.	.66668-00
9	COMPRESSIVE STRAIN-ABLATOR	-.11515-01	.20000-00	120.53 SEC.	.94242-00

TOTAL ABLATED DISTANCE IS .03975 FT.

TEMPERATURE DISTRIBUTION AT 2400.00 SECONDS							
.1541+04	.1779+04	.1917+04	.2001+04	.2047+04	.2065+04	.2058+04	.2029+04
.1813+04	.1689+04	.1515+04	.1260+04	.1187+04	.1013+04	.9718+03	.9291+03
.7637+03	.7074+03	.6660+03	.6380+03	.6218+03	.6166+03	.8822+03	.8274+03

Table 4.25 (Concluded) Case S5 Final Point

DATA FOR THE CURRENT DESIGN SPACE POINT  
 THE CURRENT VALUE OF R IS .10000-01  
 THE CURRENT VALUE OF T IS .60000-02

DESIGN POINT COORDINATES (FEET)		
XMIN	X	XMAX
.10000	.24999999	.40000
.00100	.03000000	.04000
.03125	.23000000	.30000
.00100	.03000000	.04000
.01000	.10000000	.20000
.50000	2.00000000	3.00000

SYSTEM WEIGHT= .18080+02 LBS/SQ-FT

FIACCO MC-CORMICK FUNCTION VALUE= .15180+03

BEHAVIOR CONSTRAINT INFORMATION

NUMBER	TYPE OF BEHAVIOR, UNITS	CRITICAL VALUE	LIMITING VALUE	TIME AT CRIT. VALUE	NORMALIZED VALUE
1	TEMP. AT ARL.-STR. INTERFACE (R)	.54153+03	.12000+04	900.00 SEC.	.54872-00
2	TEMP. AT RACK OF INSULATION (R)	.54000+03	.66000+03	1.00 SEC.	.18182-00
3	DISPLACEMENT AT PANEL CENTER (FT)	-.53928-02	.20000-01	1.00 SEC.	.73036-00
4	YIELD STRESS-ARLATOR (KSI)	.96985-00 .99317-00	.11185+01 .39401+01	900.00 SEC.	.22958-00
5	YIELD STRESS-UPPER SAND. FACE (KSI)	-.80470+01 -.50879+01	.16000+02	1.00 SEC.	.85396-00
6	INTERCELL FACE BUCKLING STRESS (KSI)	-.15535+01	.20086+05	.00 SEC.	.10000+01
7	YIELD STRESS-LOWER SAND. FACE (KSI)	.30261+01 -.17660+01	.16000+02	1.00 SEC.	.93117-00
8	TENSILE STRAIN-ARLATOR	.62568-02	.14800-01	900.00 SEC.	.57723-00
9	COMPRESSIVE STRAIN-ARLATOR	-.60266-02	.20000-00	5.30 SEC.	.96987-00

TOTAL ARLATED DISTANCE IS .05902 FT.

TEMPERATURE DISTRIBUTION AT 900.00 SECONDS									
.2234+04	.2548+04	.2660+04	.2648+04	.2534+04	.2315+04	.1963+04	.1299+04	.9304+03	.7173+03
.6205+03	.5769+03	.5564+03	.5467+03	.5415+03	.5400+03	.5400+03	.5400+03	.5400+03	.5400+03
.5400+03	.5400+03	.5400+03	.5400+03	.5400+03	.5400+03				

Table 4.26 Case 56 Initial Point

DATA FOR THE CURRENT DESIGN SPACE POINT  
 THE CURRENT VALUE OF R IS .10000-09  
 THE CURRENT VALUE OF T IS .10000-02

DESIGN POINT COORDINATES (FEET)		
XMIN	X	XMAX
.10000	.17248958	.40000
.00100	.00267955	.04000
.03125	.13336474	.30000
.00100	.00267955	.04000
.01000	.04100000	.20000
.50000	1.31152259	3.00000

SYSTEM WEIGHT= .8607A+01 LBS/50-FT

FIACCO MC-CORMICK FUNCTION VALUE= .8607A+01

BEHAVIOR CONSTRAINT INFORMATION

NUMBER	TYPE OF BEHAVIOR, UNITS	CRITICAL VALUE	LIMITING VALUE	TIME AT CRIT. VALUE	NORMALIZED VALUE
1	TEMP. AT ABL.-STR. INTERFACE (R)	.11200+04	.12000+04	900.00 SEC.	.00633-01
2	TEMP. AT RACK OF INSULATION (R)	.65433+03	.66000+03	900.00 SEC.	.03986-02
3	DISPLACEMENT AT PANEL CENTER (FT)	-.87754-02	.20000-01	132.14 SEC.	.50123-00
4	YIELD STRESS-ABLATOR (KSI)	.80253-00 .84921-00	.11109+01 .38414+01	388.44 SEC.	.44597-00
5	YIELD STRESS-UPPER SAND. FACE (KSI)	-.14581+02 -.15399+02	.16000+02	5.30 SEC.	.14401-00
6	INTERCELL FACE BUCKLING STRESS (KSI)	-.10224+01	.12102+03	842.51 SEC.	.93106-00
7	YIELD STRESS-LOWER SAND. FACE (KSI)	.28941+01 -.10156+02	.16000+02	5.30 SEC.	.44955-00
8	TENSILE STRAIN-ABLATOR	.52494-02	.15293-01	388.44 SEC.	.03675-00
9	COMPRESSIVE STRAIN-ABLATOR	-.10627-01	.20000-00	5.30 SEC.	.94686-00

TOTAL ABLATED DISTANCE IS .05886 FT.

TEMPERATURE DISTRIBUTION AT 900.00 SECONDS

.2201+04	.2440+04	.2577+04	.2649+04	.2673+04	.2660+04	.2612+04	.2531+04	.2415+04	.2262+04
.2073+04	.1833+04	.1473+04	.1198+04	.1120+04	.7750+03	.7517+03	.7309+03	.7128+03	.6972+03
.6840+03	.6733+03	.6650+03	.6591+03	.6555+03	.6543+03				

Table 4.26 (Concluded) Case S6 Final Point

DATA FOR THE CURRENT DESIGN SPACE POINT  
 THE CURRENT VALUE OF R IS .10000+03  
 THE CURRENT VALUE OF T IS .10000-01

DESIGN POINT COORDINATES (FEET)		
XMIN	X	XMAX
.10000	.23000000	.40000
.00100	.01000000	.04000
.03125	.10000000	.30000
.00100	.01000000	.04000
.01000	.10000000	.20000
.50000	2.00000000	3.00000

SYSTEM WEIGHT= .13436+02 LBS/SQ-FT  
 FIACCO MC-CORMICK FUNCTION VALUE= .12571+07

BEHAVIOR CONSTRAINT INFORMATION

NUMBER	TYPE OF BEHAVIOR,UNITS	CRITICAL VALUE	LIMITING VALUE	TIME AT CRIT.VALUE	NORMALIZED VALUE
1	TEMP. AT ABL.-STR. INTERFACE (R)	.54547+03	.12000+04	900.00 SEC.	.54544-00
2	TEMP. AT RACK OF INSULATION (R)	.54010+03	.66000+03	900.00 SEC.	.18167-00
3	DISPLACEMENT AT PANEL CENTER (FT)	-.85585-02	.20000-01	5.30 SEC.	.57207-00
4	YIELD STRESS-ABLATOR (KSI)	.71778-00 .72836-00	.11189+01 .39457+01	697.77 SEC.	.58232-00
5	YIELD STRESS-UPPER SAND. FACE (KSI)	-.15586+02 -.98507+01	.45000+02	5.30 SEC.	.92810-00
6	INTERCELL FACE BUCKLING STRESS (KSI)	-.16295+01	.71232+04	.00 SEC.	.10000+01
7	YIELD STRESS-LOWER SAND. FACE (KSI)	.76816+01 -.28705+01	.45000+02	5.30 SEC.	.95590-00
8	TENSILE STRAIN-ABLATOR	.46418-02	.14771-01	697.77 SEC.	.68576-00
9	COMPRESSIVE STRAIN-ABLATOR	-.84081-02	.20000-00	5.30 SEC.	.95796-00

TOTAL ARLATED DISTANCE IS .05885 FT.

TEMPERATURE DISTRIBUTION AT 900.00 SECONDS

.2219+04	.2511+04	.2621+04	.2621+04	.2531+04	.2349+04	.2059+04	.1595+04	.1148+04	.8690+03
.7105+03	.6280+03	.5843+03	.5602+03	.5455+03	.5448+03	.5432+03	.5421+03	.5414+03	.5409+03
.5406+03	.5404+03	.5402+03	.5401+03	.5401+03	.5401+03				

Table 4.27 Case 57 Initial Point

DATA FOR THE CURRENT DESIGN SPACE POINT  
 THE CURRENT VALUE OF R IS .10000-05  
 THE CURRENT VALUE OF T IS .10000-01

DESIGN POINT COORDINATES (FEET)		
XMIN	X	XMAX
.10000	.17356721	.40000
.00100	.00150267	.04000
.03125	.04992186	.30000
.00100	.00150267	.04000
.01000	.07942150	.20000
.50000	1.22151673	3.00000

SYSTEM WEIGHT= .83565+01 LBS/SQ-FT

FIACCO MC-CORMICK FUNCTION VALUE= .83708+01

BEHAVIOR CONSTRAINT INFORMATION

NUMBER	TYPE OF BEHAVIOR UNITS	CRITICAL VALUE	LIMITING VALUE	TIME AT CRIT. VALUE	NORMALIZED VALUE
1	TEMP. AT ARL.-STR. INTERFACE (R)	.10028+04	.12000+04	900.00 SEC.	.16429-00
2	TEMP. AT RACK OF INSULATION (R)	.61735+03	.66000+03	900.00 SEC.	.64614-01
3	DISPLACEMENT AT PANEL CENTER (FT)	-.18500-01	.20000-01	842.61 SEC.	.74977-01
4	YIELD STRESS-ABLATOR (KSI)	.66340-00 .67954-00	.11146+01 .38901+01	385.08 SEC.	.65693-00
5	YIELD STRESS-UPPER SAND. FACE (KSI)	-.28123+02 -.86953+01	.26220+02	852.53 SEC.	.19980-00
6	INTERCELL FACE BUCKLING STRESS (KSI)	-.42047+01	.12319+03	842.61 SEC.	.79758-00
7	YIELD STRESS-LOWER SAND. FACE (KSI)	.28100+02 .86695+01	.26656+02	852.53 SEC.	.12579-00
8	TENSILE STRAIN-ABLATOR	.43628-02	.15115-01	392.48 SEC.	.71136-00
9	COMPRESSIVE STRAIN-ABLATOR	-.11211-01	.20000-00	15.79 SEC.	.94395-00

TOTAL ARLATED DISTANCE IS .05886 FT.

TEMPERATURE DISTRIBUTION AT 900.00 SECONDS									
.2204+04	.2445+04	.2593+04	.2653+04	.2676+04	.2659+04	.2608+04	.2522+04	.2401+04	.2242+04
.2043+04	.1782+04	.1354+04	.1138+04	.1003+04	.9965+03	.9511+03	.9034+03	.8513+03	.7909+03
.7318+03	.6873+03	.6553+03	.6338+03	.6214+03	.6174+03				

Table 4.27 (Concluded) Case S7 Final Point

CHAPTER V  
CONCLUSIONS AND RECOMMENDATIONS

A. Conclusions

1. A synthesis capability for ablating thermostructural heat shield panels has been successfully completed. This capability utilizes a penalty function method in which the behavior functions are integrated over the time period of the trajectory and over the interior of the structure, thereby enabling the complete behavior response of the structure to influence the design path to be traversed. While the idea of incorporating into the penalty function the integral of a behavior function over the range of a parameter upon which it depends has been reported<sup>6</sup> in the literature of mathematical programming (in the form of a single integration), the present study is apparently the first application of the technique to a significant structural problem.

The technique does have one undesirable characteristic, which is the smoothing of the penalty function in the interior of the acceptable region. That is, the integrations cause in the behavior functions, a certain insensitivity to changes in the design variables. This is overcome to some extent by using large initial values of the parameter  $r$  in the Fiacco and McCormick Function and by changing  $r$  drastically between design cycles, as is evidenced by the  $c$  value of 100 which is used in all documented test cases. Sensitivity could be increased by using penalty functions such as

$$P(\underline{x}, r) = F(\underline{x}) + \sum_i \int_Z \int_T e^{\left[ \frac{1}{g_i(\underline{x}, z, t)} \right]} dz dt$$

or

$$P(\underline{x}, r) = F(\underline{x}) + \sum_i \int_Z \int_T \frac{dz dt}{[g_i(\underline{x}, z, t)]^q}$$

with  $q$  an even integer. Several studies were made with the first of these, but it proved to be too sensitive when a constraint was approached. Further studies could be made with various values of  $q$  in the second formula to determine a  $P(\underline{x}, r)$  function with better sensitivity properties.

2. The thermal analysis utilizes the implicit<sup>29</sup> finite difference method. As is discussed in Appendix C, no significant difference in accuracy was found to exist between the implicit and explicit methods for those cases which were tested. For Traj. I, the implicit method run time was 1/3 that required for the explicit analysis, 25 seconds vs. 75 seconds, respectively, for the 900 sec. heating period. Since the explicit method is not sensitive to the external heating rate, but is rather controlled by the material properties in the interior of the panel and the difference increments for space and time, it is to be expected that the run times required for this method are directly proportional to the total heating (or trajectory) period. Thus, for Traj. II, while the implicit method still has run times

around 25 seconds, the run time for the explicit method will be about 200 seconds, or 8 times greater than that for the implicit method. It can be concluded, based on accuracy obtained and on run time, that the implicit method is manifestly superior to the explicit method.

3. From the test case results of Chapter IV the following conclusions can be made:

- a. The design space exhibits relative minima. Several different initial design points should be used if it is suspected that the first optimum design obtained can be significantly improved.
- b. Even though fiberglass has better high temperature properties than aluminum, aluminum can yield the lighter weight structure.
- c. It is not always true that the best design is the one in which the structural layer (or ablator structure interface) operates at its maximum permitted temperature. It is customary, in current thermo-structural design studies<sup>25,26</sup>, to assume that the structural layer operates at maximum temperature.
- d. In situations where minimum wall thickness is of primary concern, a thin sheet structural layer can be superior to a sandwich structural layer.
- e. No significant reduction in weight was observed when sandwich faces of different thicknesses were permitted.



4. Because of the generality built into the computer programs, which allows any materials of known thermophysical properties to be used in the various layers, they represent a useful tool for the evaluation of materials to be used in this application.

#### B. Recommendations

1. Further effort should be directed toward improving the sensitivity of the integrated constraint penalty function along the lines suggested earlier in this chapter or in some other more suitable way.

2. Options could easily be built into the thermal analysis part of the program to allow non ablating heat shields, such as those made of ceramics, to be studied.

3. The synthesis programs should be modified so that two or more trajectories can be treated simultaneously.

4. The structural analysis should be extended so that boundary conditions other than the simple support conditions presently considered would be available as an option. Other support conditions would be the fixed condition, the elastically restrained condition, and non-uniform support conditions such as corner post supports.

5. The present structural analysis is limited to rectangular panels of aspect ratio greater than about 3, because an infinite strip model is used. A rectangular plate model should be used so that low aspect ratio plates can be studied. Also, non-flat panels such as parts of cylinders and cones could be used.

6. It is unrealistic to assume linear elastic behavior in the plastic ablator materials (LDPN) from the cure temperature of 350°F to the cold soak temperature of -100°F. Some studies of creep and stress relaxation in the ablator should be made and an analysis should be based on these results. As an alternative to this, the pretensioning process postulated in Chapter IV could be tried in order to reduce the residual (manufacturing) stress caused by the thermal expansion incompatibility of the ablator and structural layer materials.

7. The new composite materials<sup>30,31</sup> in which the fiber moduli, number of individual oriented layers in the lay-up, and layer orientation, are variables, offer the designer a wide range of thermo physical properties. They make it possible to think in terms of simultaneous design of structural configuration and structural material.<sup>32</sup> It may be possible to design a composite structural material for use in the structural layer of the panel (as a thin sheet alone or as the faces of a sandwich plate), which eliminates the thermal incompatibility problem in the thermostructural panel. A useful extension of the present study would be the development of a capability to utilize these composite materials in the structural layer. The dimensionality of the design space would thereby be increased by using as design variables those properties (fiber moduli, fiber orientation in each layer, number of layers in the finished sheet) of the composite which are not preassigned.

8. The effect of panel size on the overall expansion and contraction of the panel and thus on the size of expansion joints required between panels should be considered. Also the interaction of the heat shield structure with the primary vehicle structure should be considered. These would introduce new behavior functions such as overall panel expansion and gross buckling of the panel.

## WORKS CITED

1. Schmit, L.A., Goble, G.G., Fox, R.L., Lasdon, L., Moses, F., and Razani, R., Structural Synthesis, Summer course notes, in three volumes, Vol. I, 1965.
2. Laporte, A.H., "Research on refurbishable thermostructural panels for manned lifting entry vehicles," NASA CR 638, Nov. 1966.
3. Newell, J., "A Study of thermostructural design concepts for lifting entry vehicles," NASA CR 240, June 1965.
4. Fletcher, R. and Powell, M.J.D., "A rapidly convergent descent method for minimization," The Computer Journal, Vol. 6, No. 2, pp. 163-168, 1962.
5. Fiacco, Anthony V. and McCormick, Garth P., "Computational algorithm for the sequential unconstrained minimization technique for nonlinear programming," Management Science, Vol. 10, No. 2, pp. 601-617, July 1964.
6. Zoutendijk, G., "Nonlinear Programming: A numerical survey," J. SIAM Control, Vol. 4, No. 1, pp. 194-210, Jan. 1966.
7. Swann, R.T. and Pittman, C.M., Private communication, reproduced as Appendix A, Sept. 1965.
8. Swann, R.T. and Pittman, C.M., "Analysis of effective thermal conductivities of honeycomb-core and corrugated-core sandwich panels," NASA TN D-714, April 1961.
9. Laporte, op. cit., p. 16.

10. Ebcioğlu, I.K., "Thermo-elastic equations for a sandwich panel under arbitrary temperature distribution, transverse load, and edge compression," Proceedings of the 4th National Congress of Applied Mechanics, ASME, pp. 537-546, 1962.
11. Tsai, S.W., "Strength Characteristics of composite materials", NASA CR 224, pp. 6,7, April 1965.
12. Plantema, F. J., Sandwich Construction, Wiley, p. 52, 1966.
13. Schmit, op. cit., Vol. II, p. 6.7.
14. Fiacco, A. V. and McCormick, G.P., "The sequential unconstrained minimization technique for nonlinear programming. A primal-dual method," Management Science, Vol. 10, No. 2, pp. 360-366, Jan. 1964.
15. Swann, R.T. and Pittman, C.M., Numerical analysis of the transient response of advanced thermal protection systems for atmospheric entry," NASA TN D-1370, pp. 29-30, July 1962.
16. Newell, op. cit., pp. 12-25.
17. Wilson, R. Gale, "Thermophysical properties of six charring ablators from 140° to 700°K and two chars from 800° to 300°K," NASA TN D-2991, Oct. 1965.
18. Anon., "Metallic materials and elements for flight vehicle structures," MIL-HNBK-5, Gov't. Printing Office, Aug. 1962.
19. Anon., "Composite construction for flight vehicles," MIL-HNBK-23, Part I, Gov't. Printing Office, Oct. 1959.

20. Boller, K.H., "Strength properties of reinforced plastic laminates at elevated temperatures," ASD-TR-61-482, March 1962.
21. Laporte, op. cit., pp. 8, 96, 97.
22. Anon., "Plastics for flight vehicles", MIL-HNBK-17, Part I, Gov't. Printing Office, Nov. 1959.
23. Laporte, op. cit., pp. 10, 11, 99-102.
24. Ibid, pp. 9,10.
25. Ibid, pp. 30.
26. Newell, op. cit., p. 30.
27. Laporte, op. cit., p. 10.
28. Buck, R.C., Advanced Calculus, McGraw-Hill, pp. 126-131, 1956.
29. Forsythe, G.E. and Wasow, W.R., Finite Different Methods for Partial Differential Equations, Wiley, pp. 101-107, 1960.
30. Deitz, A.G.H., "Composite Materials", 1965 Edgar Marburg Lecture, American Society for Testing Materials.
31. Corten, H.T., "Reinforced Plastics", in Engineering Design for Plastics, Ed. by Eric Baer, Reinhold, 1964.
32. Schmit, L. A., "The Structural synthesis concept and its potential role in design with composites," The International Conference on the Mechanics of Composite Materials, Phil. Pa., May 1967.
33. Swann, R.T., Pittman, C.M., and Smith, J.C., "One Dimensional numerical analysis of the transient response of thermal protection systems", NASA-TN-D-2976, Sept. 1965.
34. Truitt, R. W., Hypersonic Aerodynamics, Ronald, 1959.

APPENDIX A  
SIMPLIFIED ABLATION ANALYSIS

This appendix contains the simplified ablation analysis formulated by R. T. Swann and C. M. Pittman of NASA Langley. The following is essentially a reproduction of a private communication from the above mentioned persons.

Simplified Ablation Analysis:

The simplification consists of neglecting all mass transfer and chemical processes which occur within the material. Certain changes in material properties which occur as a result of chemical changes can be considered. The temperature distribution within the ablator is calculated from the usual one-dimensional conduction equation,

$$\frac{\partial}{\partial x} (k_1 \frac{\partial T}{\partial x}) = \rho_1 c_{p_1} \frac{\partial T}{\partial t} \quad (\text{A.1})$$

where the coordinate system is fixed and the terms have the usual physical significance.

Ablation at the heated surface of the material is considered in detail. The energy balance at this surface is as follows:

$$\begin{array}{ccccccc} q_c (1 - \frac{h_w}{h_e}) & + & \dot{M}_1 \Delta h_c & = & \sigma \epsilon T_w^4 & - & k_w \frac{\partial T}{\partial x} \Big|_w + \\ \text{Convective} & & \text{Combustive} & & \text{reradia-} & & \text{conduction} \\ \text{Heating} & & \text{Heating} & & \text{tion} & & \\ & & & & & & \\ & & \dot{M}_1 H_{A,1} + \dot{M}_2 H_{A,2} & & & & \\ & & \text{Blocking} & & & & \end{array} \quad (\text{A.2})$$

where,

$q_c$  = convective heating

$h_w$  = stream enthalpy at wall temperature

$h_e$  = enthalpy of stream external to boundary layer (at outer edge of b.l.)

$\dot{M}_1$  = rate at which material is removed from the surface by physical removal process under consideration (discussed more fully later).

$\Delta h_c$  = heat of combustion of material at surface temperature, per unit weight of surface material; equal to approximately 5000 BTU/lb. for oxidation of carbon; equal to zero when oxidation is not considered.

$\sigma$  = Stefan-Boltzmann constant

$\epsilon$  = surface emissivity

$T_w$  = surface temperature

$k_w$  = thermal conductivity of ablative material at surface temperature

$\left. \frac{\partial T}{\partial w} \right|_w$  = temperature gradient at surface (on ablative material side)

$\dot{M}_2$  = rate at which material, which would actually have been removed within the ablator, is assumed to be removed at surface.

$H_{A,1}$  = heat of ablation of  $M_1$ ;  $H_{A,1} = \Delta h_1 + \eta_1 (h_e - h_w)$

$\Delta h$  = heat of vaporization or fusion

$\eta_1$  = blocking effectiveness parameter



$$H_{A,2} = \text{heat of ablation of } \dot{M}_2, H_{A,2} = \eta_2 (h_e - h_w)$$

$$\eta_2 = \text{blocking effectiveness parameter}$$

Mass Loss Rate: The critical problem in determining ablative performance is the calculation of surface recession rate. Two mechanisms of surface recession are of particular interest: oxidation of a carbonaceous surface, and melting and vaporization of a glassy surface. These mechanism apply respectively to phenolic-base and silicone base materials.

Oxidation - The rate of removal of material as a result of oxidation is determined from the following equation<sup>33</sup>

$$\dot{M}_1 = \frac{1}{2} \left[ \frac{(h_c - h_w) K^2 p_w}{q_{c,net} \lambda N_{Le}^6} \right]^{1/2} + 4K^2 p_w C_e^{1/2} - \frac{(h_e - h_w) K^2 p_w}{q_{c,net} \lambda N_{Le}^6} \quad (A.3)$$

where  $\lambda$  = mass of material removed/unit mass of oxygen

$N_{Le}$  = Lewis number

$q_{c,net}$  = Hot wall convective heating rate corrected for blocking:

$$q_{c,net} = q_c \left( 1 - \frac{h_w}{h_e} \right) - (\dot{M}_1 H_{A,1} + \dot{M}_2 H_{A,2})$$

$C_e$  = Oxygen concentration exterior to boundary layer

$p_w$  = Pressure at wall =  $\frac{11}{12} \rho_\infty V_\infty^2$  (Truitt<sup>34</sup>). (A.4)

$K$  = reaction rate constant for carbon-oxygen reaction,

$$K = A e^{-B/T} \quad A = 6.73 \times 10^8$$

$$B = 4.0 \times 10^4 \text{ } ^\circ\text{R}$$

For large K, eq. (A.3) reduces to the following form:

$$\dot{M}_1 = N_{Le}^{.6} \lambda C_e \frac{q_{c,net}}{h_e - h_w} \quad (A.5)$$

**Melting** - For a material which produces a surface melt layer, the surface temperature is assumed to have a known upper bound  $T_A$ . When this temperature is reached, Eq. (A.2) is solved for  $\dot{M}_1$ . The known surface temperature  $T_A$  provides the boundary condition (at the heated surface) which is required for solution of equation A.1.

With the present simplified approach,  $\dot{M}_2$  is calculated from the following equation, for both oxidation and melting.

$$\dot{M}_2 = \frac{f}{1-f} \dot{M}_1 \quad (A.6)$$

where  $f$  is the volatile fraction (that is, the fraction of the material which actually vaporizes or degrades within the ablator, rather than at the surface).

**Surface Recession:** As a result of the ablation which occurs at the heated surface, that surface recedes at a rate

$$\dot{s} = \frac{\dot{M}_1 + \dot{M}_2}{\rho_1} \quad (A.7)$$

The surface recession must, of course, be considered in solving Eq. (A.1). This is best accomplished by transforming to a coordinate system which is fixed at both boundaries, for example

$$\zeta = \frac{x - s}{x_1 - s} \quad (A.8)$$

where  $\zeta$  = transformed coordinate  
 $x$  = distance from initial location of heated surface  
 $s$  = total surface recession  
 $x_1$  = initial thickness of ablative material.

**Back Surface Boundary Condition:** The boundary condition at the back surface of an ablator depends on the configuration. Formulation of this condition is not influenced by the occurrence of ablation at the heated surface. Usually, continuity of temperature and heat flux between the ablator and supporting material will be imposed. The boundary conditions considered in the present analysis are described in the main body of the report.

APPENDIX B  
SANDWICH PLATE ANALYSIS

The notation used in the following analysis follows that of Ebcioğlu<sup>10</sup>. The bending rigidity of the faces is retained and the following assumptions are used:

1. Face to core bond failure does not occur
2. Core is homogeneous and cell size is much smaller than panel size
3. Transverse shear deformation of the faces and the ablator is negligible
4. Poisson's ratios for all materials are the same
5. Only transverse shear stress exists in the core
6. Transverse normal strains in the core are negligible
7. There is no thermal gradient in the sandwich faces.  
There is a gradient in the ablator.
8. There is no slippage or bond failure between the upper face and the ablator.

Figure B-1 shows some of the pertinent geometrical quantities. Primed quantities refer to the upper composite face while double primed quantities refer to the lower face. The coordinate  $z'$  is measured from the neutral axis of the upper face,  $z''$  is measured from the centroidal axis of the lower face (since the lower face has no thermal gradient, this corresponds to the neutral axis), and  $z$  is measured from the neutral axis

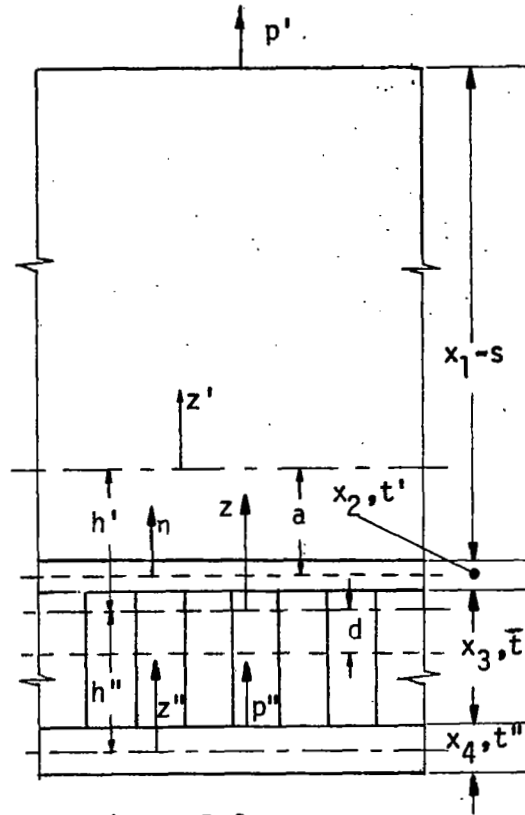

Figure B-1

of the entire cross section. These coordinate reference planes are determined by evaluating the following integrals:

$$\text{For } z': \int_{A'} E z' dz' = 0 \quad (B-1)$$

$$\text{For } z'': \int_{A''} E z'' dz'' = 0 \quad (B-2)$$

$$\text{For } z: \int_A E z dz = 0 \quad (B-3)$$

where  $A'$  is the cross-sectional area of the upper composite face (unit length in the  $y$  direction),  $A''$  is the area of the lower face, and  $A$  is the area of the entire cross-section.

The distance " $d$ " locates the neutral plane of the entire cross-section with respect to the geometric center of the core, and " $a$ " is the distance between the neutral plane of the topface-ablator system and the midplane of the topface.

Figure B-2 shows the deformation of the composite panel.  $u'$  and  $u''$  are the in-plane displacements at the neutral planes of the top and bottom faces, respectively. The displacement variation through the upper face is given by

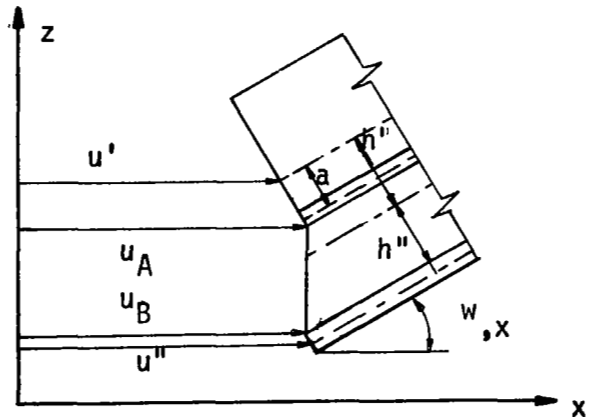

Figure B-2

$$u(x, z') = u'(x) - z' w_{,x}(x) \quad (B-4)$$

while for the lower face

$$u(x, z'') = u''(x) - z'' w_{,x}(x) \quad (B-5)$$

The stress-strain equations for each face are the same as those given by Eqs. (2.13) of the thin sheet analysis and force and moment resultants can be defined, as

$$N_{xx}' = \int_{A'} \sigma_{xx} dz' = K' [u_{,x}' + v \bar{c}] - N' \quad (B-6)$$

$$N_{xx}'' = \int_{A''} \sigma_{xx} dz'' = K'' [u_{,x}'' + \bar{c}] - N''$$

$$N_{yy}' = K' [v u_{,x}' + \bar{c}] - N'$$

$$N_{yy}'' = K'' [v u_{,x}'' + \bar{c}] - N''$$

$$M_{xx}' = \int \sigma_{xx} z' dz' = -D' w_{,xx} - M' \quad (B-6)$$

$$M_{xx}'' = \int \sigma_{xx} z'' dz'' = -D'' w_{,xx} - M''$$

$$M_{yy}' = \int \sigma_{yy} z' dz' = -v D' w_{,xx} - M'$$

$$M_{yy}'' = -v D'' w_{,xx} - M''$$

where

$$K' = \frac{Q_1}{1-\nu^2}$$

$$K'' = \frac{E'' t''}{1-\nu^2}$$

$$D' = \frac{1}{1-\nu^2} (Q_3 - a Q_2)$$

$$D'' = \frac{E'' t''^3}{12(1-\nu^2)} \quad (B-7)$$

$$N' = Q_4$$

$$N'' = \frac{1}{1-\nu} t'' E'' \alpha'' (\Delta T)''$$

$$M' = Q_5 - a Q_4$$

$$M'' = 0$$

The parameters  $Q_1, \dots, Q_5$  are as previously defined in the thin sheet analysis of Chapter II.

The shear strain in the core is given by

$$\bar{\gamma}_{zx} = \frac{\partial u}{\partial z} + \frac{\partial w}{\partial x} \quad (B-8)$$

From Figure B-2,  $\frac{\partial u}{\partial z} = \frac{u_A - u_B}{\bar{t}}$  in the core.

$$\text{But } u_A = u' + \left(\frac{t'}{2} + a\right) w_{,x}$$

and

$$u_B = u'' - \left(\frac{t''}{2}\right) w_{,x}$$

so that

$$\bar{\gamma}_{zx} = \frac{1}{\bar{t}} \left[ u' + \left(\frac{t'}{2} + a\right) w_{,x} - u'' + \frac{t''}{2} w_{,x} \right] + w_{,x}$$

or

$$\bar{\gamma}_{zx} = \frac{u' - u''}{\bar{t}} + \hat{t} w_{,x} \quad (B-9)$$

where

$$\hat{t} = (\bar{t} + \frac{t'}{2} + \frac{t''}{2} + a) / \bar{t} \quad (B-10)$$

The shear stress-strain relationship is



$$\bar{\sigma}_{zx} = \bar{G}_{zx} \bar{\gamma}_{zx} \quad (B-11)$$

Defining a shear stress resultant as

$$\bar{Q}_{zx} = \bar{t} \bar{\sigma}_{zx} \quad (B-12)$$

Eq. (B-11) becomes

$$\frac{\bar{Q}_{zx}}{\bar{t}} = \bar{G}_{zx} \left[ \frac{u' - u''}{\bar{t}} + \hat{t} w_{,x} \right] \text{ or}$$

$$\bar{Q}_{zx} = \bar{G}_{zx} [(u' - u'') + \bar{t} \hat{t} w_{,x}] \quad (B-13)$$

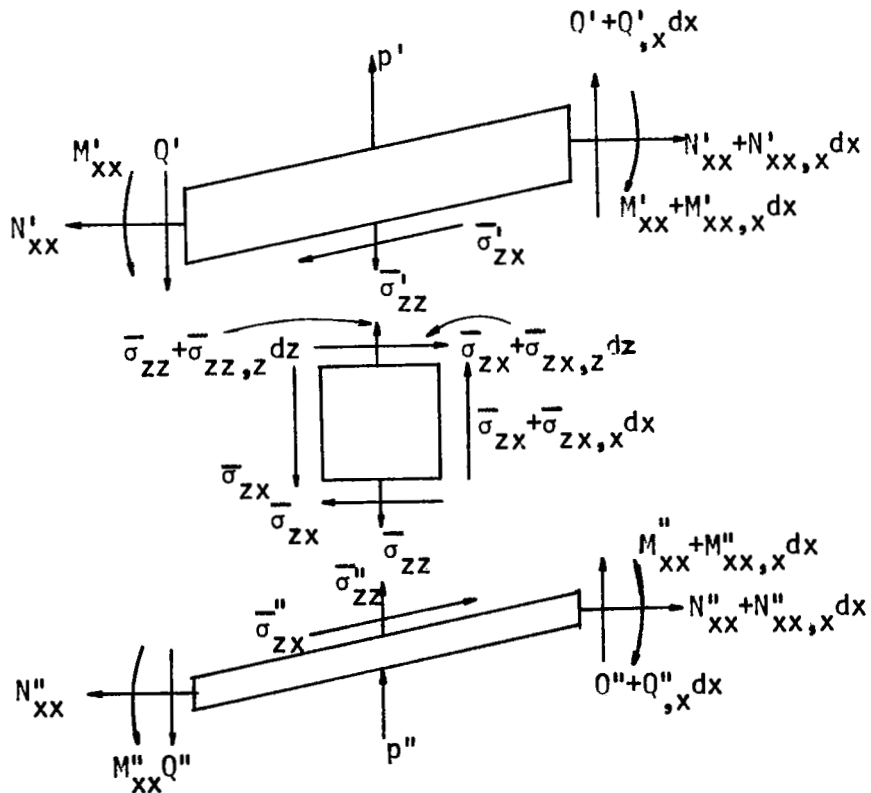

Figure B-3

Equilibrium of the faces and the core is described by the following equations which involve the forces shown in Fig. B-3. Barred quantities refer to the core. Equilibrium equations are written for each of the faces, and the core, separately.

For the upper face:

$$\begin{aligned}
 N'_{xx,x} - \bar{\sigma}'_{zx} &= 0 \\
 p' - \bar{\sigma}'_{zx} w_{,x} - \bar{\sigma}'_{zz} + Q'_{,x} &= 0 \\
 -M'_{xx,x} - N'_{xx} w_{,x} - \bar{\sigma}'_{zx} \left(\frac{t'}{2} + a\right) + Q' &= 0
 \end{aligned}
 \tag{B-14}$$

For the lower face

$$\begin{aligned}
 N''_{xx,x} + \bar{\sigma}''_{zx} &= 0 \\
 p'' + \bar{\sigma}''_{zx} w_{,x} + \bar{\sigma}''_{zz} + Q''_{,x} &= 0 \\
 -M''_{xx,x} - N''_{xx} w_{,x} - \bar{\sigma}''_{zx} \left(\frac{t''}{2}\right) + Q'' &= 0
 \end{aligned}
 \tag{B-15}$$

For the core

$$\begin{aligned}
 \frac{\partial \bar{\sigma}_{zx}}{\partial z} &= 0 \\
 \frac{\partial}{\partial x} \bar{\sigma}_{zx} + \frac{\partial \bar{\sigma}_{zz}}{\partial z} &= 0
 \end{aligned}
 \tag{B-16}$$

Equation(B-16a) implies that  $\bar{\sigma}_{zx}$  is not a function of  $z$ , or that

$$\bar{\sigma}'_{zx} = \bar{\sigma}''_{zx} \equiv \bar{\sigma}_{zx}
 \tag{B-17}$$

Equation (B-16b) can now be integrated over the core

$$\int \left[ \frac{d}{dx} \bar{\sigma}_{zx} + \frac{\partial \sigma_{zz}}{\partial z} \right] dz = \frac{d}{dx} (\bar{t} \bar{\sigma}_{zx}) + (\bar{\sigma}_{zz}' - \bar{\sigma}_{zz}'') = 0$$

and from the definition, eq. (B-12),

$$\bar{Q}_{zx,x} = \bar{\sigma}_{zz}'' - \bar{\sigma}_{zz}' \quad (B-18)$$

Adding equations (B-14b) and B-15b) and using (B-17) and (B-18) the following equation is obtained

$$p' + p'' + \bar{Q}_{zx,x} + Q'_{,x} + Q''_{,x} = 0 \quad (B-19)$$

Now, by differentiating Eqs. (B-14c) and (B-15c), and solving for  $Q'_{,x}$  and  $Q''_{,x}$ , respectively, these quantities can be eliminated from Eq. (B-19), to give

$$p' + p'' + \bar{Q}_{zx,x} + M'_{xx,xx} + M''_{xx,xx} + [(N'_{xx} + N''_{xx}) w_{,x}]_{,x} + \frac{\bar{Q}_{zx,x}}{\bar{t}} \left( \frac{t'}{2} + \frac{t''}{2} + a \right) = 0$$

and since, from equations (B-14a) and (B-15a),  $N'_{xx,x} + N''_{xx,x} = 0$

$$p' + p'' + \hat{t} \bar{Q}_{zx,x} + M'_{xx,xx} + M''_{xx,xx} + (N'_{xx} + N''_{xx}) w_{,xx} = 0 \quad (B-20)$$

Finally, the equilibrium equations (B-14), (B-15) and (B-16) reduce to the following set of three equations

$$\begin{aligned} N'_{xx,x} - \frac{\bar{Q}_{zx}}{\bar{t}} &= 0 \\ N''_{xx,x} + \frac{\bar{Q}_{zx}}{\bar{t}} &= 0 \end{aligned} \quad (B-21)$$

$$- M'_{xx,xx} - M''_{xx,xx} - \hat{t} Q_{zx,x} = p' + p'' + (N'_{xx} + N''_{xx}) w_{,xx}$$

At this point, some new quantities are defined. These will simplify the subsequent results. Define the total axial force in the x direction as

$$N_{xx} = N'_{xx} + N''_{xx} \quad (B-22)$$

and in the y direction

$$N_{yy} = N'_{yy} + N''_{yy} \quad (B-23)$$

These forces act on the neutral plane of the composite section as in Figure B.4.

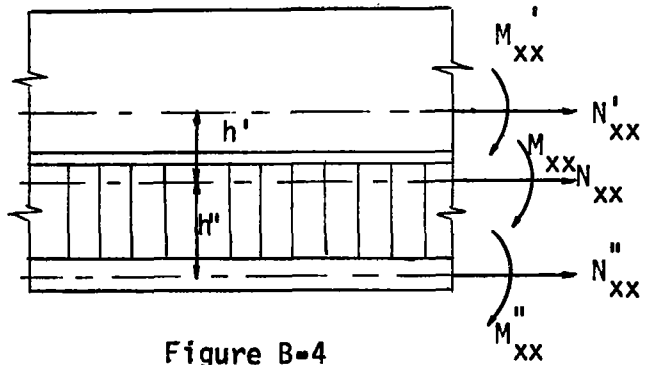

Figure B-4

The total moment acting on the x cross section is

$$M_{xx} = M'_{xx} + M''_{xx} + h' N'_{xx} - h'' N''_{xx} \quad (B-24)$$

and a similar expression can be written for a y cross section.  $h'$  and  $h''$  can be written in terms of the properties of the composite cross-section by evaluating the integral in equation (B-3). Performing the operations to do this, it can be shown that

$$h' = \frac{1}{1+m} \bar{t} \hat{t} \quad (B-25)$$

$$h'' = \frac{m}{1+m} \bar{t} \hat{t} \quad (B-26)$$

$$m = \frac{h''}{h'} = \frac{K'}{K''} = \frac{Q_1}{E'' \hat{t}''} \quad (B-27)$$

where "m" is the axial stiffness ratio of the faces. Equation (B-24) can now be written as

$$M_{xx} = M'_{xx} + M''_{xx} + \frac{1}{1+m} \bar{t} \hat{t} (N'_{xx} - m N''_{xx}) \quad (B-28)$$

As in the case of the thin sheet structure, the panel is allowed to expand freely in the x and y coordinate directions and curvature in the y direction is suppressed. Thus the total axial force in the x and y directions must vanish, or

$$N_{xx} = N_{yy} = 0 \quad (B-29)$$

If the panel is simply supported on the x edges, then

$$w(\pm \ell) = 0 \quad (B-30)$$

and

$$M_{xx}(\pm \ell) = 0 \quad (B-31)$$

An additional boundary condition is that the shear in the core at the edges is zero, or

$$\bar{\gamma}_{zx}(\pm \ell) = 0 \quad (B-32)$$

A displacement formulation will be used to effect the solution to this problem. Using the force and moment resultant-displacement equations (B-6), and (B-13), the forces can be eliminated from the equilibrium equations (B-21) and the boundary and auxiliary conditions as given by equations (B-29), (B-30), (B-31) and (B-32). Thus the field equations can be written as

$$K' u'_{,xx} - \frac{\bar{G}_{zx}}{\bar{t}} [\bar{t} \hat{t} w_{,x} + (u' - u'')] = 0 \quad (B-33)$$

$$\frac{K'}{m} u''_{,xx} + \frac{\bar{G}_{zx}}{\bar{t}} [\bar{t} \hat{t} w_{,x} + (u' - u'')] = 0$$

$$\begin{aligned} (D' + D'') w_{,xxxx} - \hat{t} G_{zx} [\bar{t} \hat{t} w_{,xx} + (u'_{,x} - u''_{,x})] \\ = p' + p'' + N_{xx} w_{,xx} \end{aligned}$$

while

$$N_{xx} = K' [u'_{xx} + \frac{1}{m} u''_{xx} + \nu (\frac{1+m}{m}) \bar{c}] - N \quad (B-34)$$

$$N_{yy} = K' [(\frac{1+m}{m}) \bar{c} + \nu (u'_{,x} + \frac{1}{m} u''_{,x})] - N \quad (B-35)$$

and

$$M_{xx} = -(D' + D'') w_{,xx} + \frac{\bar{t} \hat{t}}{1+m} K' (u'_{,x} - u''_{,x}) - M - (M' + M'')$$

where  $N \equiv N' + N'' \quad (B-37)$

$$M \equiv \frac{\bar{t} \hat{t}}{1+m} (N' - m N'') \quad (B-38)$$

If the first two of equations (B-33) are added, the result is

$$K' (u'_{,xx} + \frac{1}{m} u''_{,xx}) = 0 \quad (B-39)$$

while if the second of eq. (B-33) is multiplied by  $m$  and then is subtracted from the first of Eq.(B-33),

$$K' (u'_{,xx} - u''_{,xx}) - (1+m) \frac{\bar{G}_{zx}}{\bar{t}} [\bar{t} \hat{t} w_{,x} + (u' - u'')] = 0 \quad (B-40)$$

Summarizing, the field equations can be written as

$$\begin{aligned} K' (u'_{,xx} + \frac{1}{m} u''_{,xx}) &= 0 \\ K' (u'_{,xx} - u''_{,xx}) - (1+m) \frac{\bar{G}_{zx}}{\bar{t}} [\bar{t} \hat{t} w_{,x} + (u' - u'')] &= 0 \end{aligned} \quad (B-41)$$

$$\begin{aligned} (D' + D'') w_{,xxxx} - \bar{t} \bar{G}_{zx} [\bar{t} \hat{t} w_{,xx} - (u'_{,x} - u''_{,x})] &= p' + p'' \\ &+ N_{xx} w_{,xx} \end{aligned}$$

while the force resultants are given by

$$\begin{aligned} N_{xx} &= K' [u'_{,x} + \frac{1}{m} u''_{,x} + \nu (\frac{1+m}{m}) \bar{c}] - N \\ N_{yy} &= K' [(\frac{1+m}{m}) \bar{c} + \nu (u'_{,x} + \frac{1}{m} u''_{,x})] - N \end{aligned} \quad (B-42)$$

and the moment result is given by

$$M_{xx} = - (D' + D'') w_{,xx} + \frac{\bar{t} \hat{t} K'}{(1+m)} (u'_{,x} - u''_{,x}) - M - (M' + M'') \quad (B-43)$$

and the shear in the case is

$$\bar{\gamma}_{zx} = \bar{G}_{zx} [\bar{t} \hat{t} w_{,x} + (u' - u'')] \quad (B-44)$$

Equations (B-41), (B-42), (B-43) and (B-44) are sufficient to determine completely the stress and displacement state in the composite panel. It will be noticed that these equations depend on  $u'$  and  $u''$  only through the quantities  $u' + \frac{1}{m} u''$ ,  $u' - u''$ , and their derivatives. Hence, if the following variables are defined,

$$\bar{u} = u' + \frac{1}{m} u'' \quad (B-45)$$

$$u = u' - u''$$

the governing equations can be written as

$$\bar{u}_{,xx} = 0$$

$$\left[ \frac{K'}{(1+m)} \frac{\bar{t}}{\bar{G}_{zx}} \right] u_{,xx} - \bar{t} \hat{t} w_{,x} - u = 0 \quad (B-46)$$

$$\left[ \frac{(D' + D'')}{\hat{t} \bar{G}_{zx}} \right] w_{,xxxx} - \bar{t} \hat{t} w_{,xx} - u_{,x} = p' + p'' + N_{xx} w_{,xx}$$

$$N_{xx} = K' \left[ \bar{u}_{,x} + \nu \left( \frac{1+m}{m} \right) \bar{c} \right] - N$$

$$N_{yy} = K' \left[ \left( \frac{1+m}{m} \right) \bar{c} + \nu \bar{u}_{,x} \right] - N \quad (B-47)$$

$$M_{xx} = - (D' + D'') w_{,xx} + \frac{\bar{t} \hat{t} K'}{1+m} u_{,x} - M - (M' + M'')$$

$$\bar{\gamma}_{zx} = \bar{G}_{zx} [\bar{t} \hat{t} w_{,x} + u]$$



After equations (B-46), and (B-47) are solved for  $u$ ,  $\bar{u}$ , and  $w$ ,  $u'$  and  $u''$  can be obtained by inverting eqs. (B-45) to yield

$$u' = \left(\frac{m}{1+m}\right) (\bar{u} + \frac{1}{m} u) \quad (B-48)$$

$$u'' = \left(\frac{m}{1+m}\right) (\bar{u} - u)$$

Equations (B-46) and (B-47) can be separated into two distinct sets when  $N_{xx} = N_{yy} = 0$ . Thus, the first set is

$$\bar{u}_{,xx} = 0 \quad -\ell < x < +\ell$$

$$N_{xx} = K' [\bar{u}_{,x} + v \left(\frac{1+m}{m}\right) \bar{c}] - N = 0 \quad x = \pm \ell \quad (B-49)$$

$$N_{yy} = K' \left[\left(\frac{1+m}{m}\right) \bar{c} + v \bar{u}_{,x}\right] - N = 0 \quad \text{all } y$$

Equations (B-49) can be solved for  $\bar{u}$  and  $\bar{c}$ , as

$$\bar{c} = \frac{1}{1+v} \left(\frac{m}{1+m}\right) \frac{N}{K'} \quad (B-50)$$

$$\bar{u}(x) = \left[\frac{1}{1+v} \frac{N}{K'}\right] x \quad (B-51)$$

This solution for  $\bar{u}(x)$  results in  $N_{xx} \equiv 0$  for all  $x$ . With  $p' = p_w$  and  $p'' = 0$ , and  $N_{xx} \equiv 0$ , the second set of equations is

$$\left\{ \begin{array}{l} k_1 u_{,xx} - \bar{c} \hat{t} w_{,x} - u = 0 \\ k_2 w_{,xxxx} - \bar{c} \hat{t} w_{,xx} - u_{,x} = p_w \end{array} \right\} \quad -\ell < x < \ell \quad (B-52)$$

$$\left. \begin{aligned} M_{xx} &= -k_3 w_{,xx} + k_4 u_{,x} - M - (M' + M'') = 0 \\ w &= 0 \\ \bar{\gamma}_{zx} &= \bar{G}_{zx} [\bar{t} \hat{t} w_{,x} + u] = 0 \end{aligned} \right\} x = \pm l \quad (B-53)$$

where  $k_1 = \frac{\bar{t} K'}{\bar{G}_{zx} (1+m)}$

$$k_2 = \frac{(D' + D'')}{\hat{t} \bar{G}_{zx}} \quad (B-54)$$

$$k_3 = D' + D''$$

$$k_4 = \frac{\bar{t} \hat{t} K'}{1+m}$$

The complementary solution to equations B-52 is of the form

$$\begin{aligned} w_c(x) &= A e^{\lambda x} \\ u_c(x) &= B e^{\lambda x} \end{aligned} \quad (B-55)$$

which yields, upon substitution into B-52, the following characteristic equation for  $\lambda$ :

$$[k_1 k_2 \lambda^2 - (\bar{t} \hat{t} k_1 + k_2)] \lambda^4 = 0$$

so that

$$\lambda_{1,2} = \pm \frac{\bar{t} \hat{t} k_1 + k_2}{k_1 k_2} = \pm r \quad (B-56)$$

$$\lambda_{3,4,5,6} = 0$$

Hence

$$w_c(x) = A_1 e^{rx} + A_2 e^{-rx} + A_3 + A_4 x + A_5 x^2 + A_6 x^3 \quad (B-57)$$

$$u_c(x) = B_1 e^{rx} + B_2 e^{-rx} + B_3 + B_4 x + B_5 x^2 + B_6 x^3$$

The origin of the  $x$  coordinate was chosen at the center of the span. The structure and the loading are each symmetric with respect to a vertical axis through this origin. Hence, the response,  $w_c$ , must be symmetric (an even function of  $x$ ) with respect to this vertical axis, and the response,  $u_c$ , must be antisymmetric (an odd function of  $x$ ) with respect to the vertical axis. Thus

$$w_c(x) = w_c(-x) \quad (B-58)$$

$$u_c(x) = -u_c(-x)$$

Replacing the exponentials in Eqs. B-57 by the corresponding hyperbolic functions

$$u_c(x) = (A_1 + A_2) \cosh rx + (A_1 - A_2) \sinh rx + A_3 + A_4 x + A_5 x^2 + A_6 x^3$$

$$u_c(x) = (B_1 + B_2) \cosh rx + (B_1 - B_2) \sinh rx + B_3 + B_4 x + B_5 x^2 + B_6 x^3$$

and utilizing equation B-58, the solution is

$$w_c(x) = A_1 \cosh rx + A_2 + A_3 x^2 \quad (B.57')$$

$$u_c(x) = B_1 \sinh rx + B_2 x + B_3 x^3$$

where the constants have been subjected to obvious redefinition.

Substitution of (B.57') into (B-52) yields

$$\begin{aligned} B_3 &= 0 \\ B_2 &= -2 \bar{t} \hat{t} A_3 \\ B_1 &= r \left( \frac{k_2}{k_1} \right) A_1 \equiv \alpha A_1 \end{aligned} \tag{B-59}$$

so that the complementary solution is of the form

$$\begin{aligned} w_c(x) &= A_1 \cosh rx + A_2 + A_3 x^2 \\ u_c(x) &= \alpha A_1 \sinh rx - 2 \bar{t} \hat{t} A_3 x \end{aligned} \tag{B-60}$$

The complete solution consists of the complementary solution (B-60) of the homogeneous set of differential equations, plus a particular solution of the non-homogeneous set. The form of equations (B-52) is such that if the load term were expanded in a Fourier cosine series, then a similar cosine series for  $w_p(x)$  and a sine series for  $u_p(x)$  would be a particular solution. The load  $p_w$ , when expanded into a Fourier cosine series, is written

$$p_w = \frac{4}{\pi} p_w \sum_{n=1}^{\infty} \frac{(-1)^{n+1}}{(2n-1)} \cos \Omega_n x \equiv \frac{4}{\pi} p_w \sum_{n=1}^{\infty} P_n \cos \Omega_n x \tag{B-61}$$

with

$$\Omega_n \equiv \frac{(2n-1)\pi}{x_6} \tag{B-62}$$

Now,  $w_p(x)$  and  $u_p(x)$  can be written symbolically as

$$u_p(x) = \sum_{n=1}^{\infty} U_n \sin \Omega_n x \quad (\text{B-63})$$

$$w_p(x) = \sum_{n=1}^{\infty} W_n \cos \Omega_n x \quad (\text{B-64})$$

Substitution of (B-61), (B-63) and (B-64) into (B-52) yields

$$\begin{bmatrix} \bar{t} \hat{t} \Omega_n & (k_1 \Omega_n^2 + 1) \\ (k_2 \Omega_n^4 + \bar{t} \hat{t} \Omega_n^2) & -\Omega_n \end{bmatrix} \begin{Bmatrix} W_n \\ U_n \end{Bmatrix} = \begin{Bmatrix} 0 \\ P_n \end{Bmatrix}$$

Thus,

$$W_n = \frac{(k_1 \Omega_n^2 + 1) P_n}{D_n}$$

$$U_n = \frac{\bar{t} \hat{t} \Omega_n P_n}{D_n} \quad (\text{B-65})$$

$$D_n = k_1 k_2 \Omega_n^6 + (\bar{t} \hat{t} k_1 + k_2) \Omega_n^4$$

The complete solution is

$$w(x) = A_1 \cosh rx + A_2 + A_3 x^2 + w_p(x) \quad (\text{B-66})$$

$$u(x) = \alpha A_1 \sinh rx - 2 \bar{t} \hat{t} A_3 x + u_p(x)$$

The three unknown coefficients  $A_1$ ,  $A_2$  and  $A_3$  are determined from the boundary conditions (B-53) applied  $x = \pm l$ . The resulting

coefficients are

$$A_3 = -\frac{1}{2} \frac{M_T}{D_T} \quad (\text{B-67})$$

with

$$M_T = M + M' + M'' \quad (\text{B-68})$$

and

$$D_T = k_3 + \bar{t} \hat{t} k_4 \quad (\text{B-69})$$

$$A_1 = -\frac{-u_p|_{\ell} - \bar{t} \hat{t} w_{p,x}|_{\ell}}{\sinh r\ell (\alpha + \bar{t} \hat{t} r)} \quad (\text{B-70})$$

$$A_2 = - (A_1 \cosh r\ell + \ell^2 A_3) \quad (\text{B-71})$$

Note that in the special case when the bending rigidity of the faces vanishes, i.e.  $k_2 \rightarrow 0$ , the coefficient  $A_1 \rightarrow 0$ . The remaining coefficients  $A_2$  and  $A_3$  are determined so that the first two boundary conditions in equation (B-53) are satisfied as in equation (B-67) and (B-71). The shear condition at the edges is not satisfied.

From  $w(x)$  and  $u(x)$  the stresses can be computed through the use of the stress-strain and strain displacement equations, as

$$\sigma'_{xx} = \frac{E'}{1-\nu^2} [u'_{,x} - z' w_{,xx} + \nu \bar{c}] - \frac{E' \alpha' (\Delta T)'}{1-\nu}$$

$$\sigma'_{yy} = \frac{E'}{1-\nu^2} [\bar{c} + \nu (u'_{,x} - z' w_{,xx})] - \frac{E' \alpha' (\Delta T)'}{1-\nu}$$

$$\sigma_{xx}'' = \frac{E''}{1-\nu^2} [u''_{,x} - z'' w_{,xx} + \nu \bar{c}] - \frac{E'' \alpha'' (\Delta T)''}{1-\nu}$$

$$\sigma_{yy}'' = \frac{E''}{1-\nu^2} [\bar{c} + \nu (u''_{,x} - z'' w_{,xx})] - \frac{E'' \alpha'' (\Delta T)''}{1-\nu}$$

$$\bar{\sigma}_{zx} = \frac{\bar{G}}{\bar{t}} [z \hat{t} w_{,x} + (u' - u'')]$$

Failure due to yielding will be based on the Von Mises yield criterion.

## APPENDIX C

### FINITE DIFFERENCE FORMULATION OF HEATING PROBLEM

#### I. Thin Sheet Structural Layer

An implicit finite difference formulation is used to solve the thermal problem. The basic equations have been set down in Appendix A.

Central differences of  $o(h^2)$  are used for space derivatives in all equations except the interface condition which is correct to  $O(h)$ . The reason for this will be explained in the sequel. The "whole station" method has been used.

Field Equation for the Ablator:

This is equation (2.3):

$$\rho_1 c_{p1} \left( \frac{\partial T}{\partial t} \right)_\xi = \frac{k_1}{(x_1-s)^2} \left( \frac{\partial^2 T}{\partial \xi^2} \right)_t + \left[ \rho_1 c_{p1} \frac{\dot{s}(1-\xi)}{(x_1-s)} + \frac{1}{(x_1-s)^2} \frac{\partial k_1}{\partial \xi} \right] \left( \frac{\partial T}{\partial \xi} \right)_t \quad (C.1)$$

The derivatives are approximated by

$$\frac{\partial T}{\partial t} = \frac{T_{i,t+k_j} - T_{i,t}}{k_j} \quad (C.2)$$

$$\frac{\partial^2 T}{\partial \xi^2} = \frac{T_{i-1,t+k_j} - 2T_{i,t+k_j} + T_{i+1,t+k_j}}{h_1^2} \quad (C.3)$$

$$\frac{\partial T}{\partial \xi} = \frac{-T_{i-1,t+k_j} + T_{i+1,t+k_j}}{2h_1} \quad (C.4)$$

where  $k_j$  is the present increment of time and  $h_1$  is the increment in  $\xi$ .



The first subscript on T denotes the spatial point of interest,

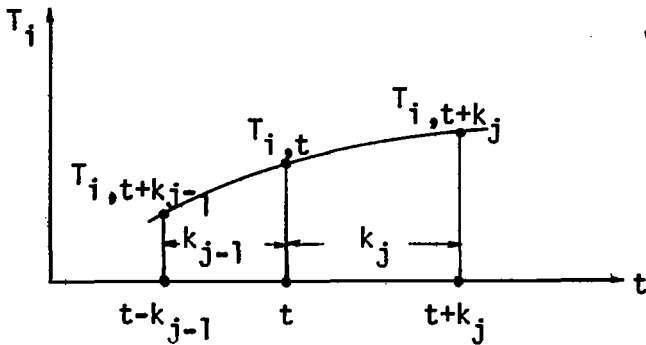

while the second subscript denotes the time. The significance of  $t+k_j$  is shown on Figure (C.1)

Figure C.1

The system is idealized as shown in Figure (C.2). The structural

layer is treated as though it

were a film of negligible

thickness, which has a

heat capacity but no

thermal gradient. There

are  $m-2$  stations in the

ablator and  $n-m-1$  stations

in the insulator, plus three

boundary stations, for a total

of  $n-m-1 + m-2+3 = n$  stations.

The spatial increments in

ablator, and in the insulator

are

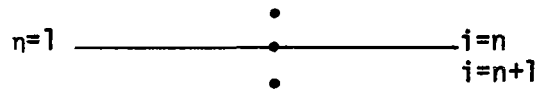
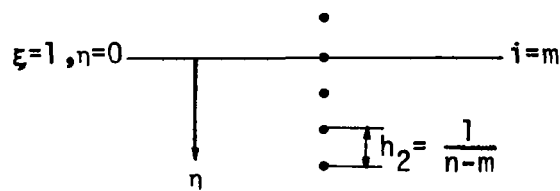
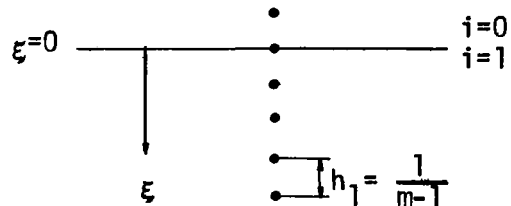

Figure C.2

$$h_1 = 1/(m-1) \quad (C.5)$$

$$h_2 = 1/(n-m) \quad (C.6)$$

Substitution of (C.2), (C.3) and (C.4) into (C.1) yields

$$[-\lambda_{1j} f_{1i,t+k_j} + \frac{1}{2} h_1 \lambda_{1j} g_{1i,t+k_j}] T_{i-1,t+k_j} \quad (C.7)$$

$$+[1+2 \lambda_{1j} f_{1i,t+k_j}] T_{i,t+k_j} + [-\lambda_{1j} f_{1i,t+k_j}$$

$$- \frac{1}{2} h_1 \lambda_{1j} g_{1i,t+k_j}] T_{i+1,t+k_j} = T_{i,t}$$

where

$$\lambda_{1j} = \frac{k_j}{h_1^2} \quad (C.8)$$

$$f_{1i,t+k_j} = \frac{k_{1i,t+k_j}}{\rho_{1i,t+k_j} C_{P1i,t+k_j} (x_1-s)^2_{t+k_j}} \quad (C.9)$$

$$g_{1i,t+k_j} = \frac{\dot{s}_{t+k_j} (1-\xi)}{(x_1-s)^2_{t+k_j}} + \frac{1}{(x_1-s)^2_{t+k_j} \rho_{1i,t+k_j} C_{P1i,t+k_j}} \left. \frac{\partial k_1}{\partial \xi} \right|_{i,t+k_j} \quad (C.10)$$

where  $\left. \frac{\partial k_1}{\partial \xi} \right|_{i,t+k_j}$  is approximated by a backward, forward, or central difference operator of  $O(h^2)$ ; ( $h = \max(h_1, h_2)$ ), depending on whether it is applied at a boundary point or at a field point.

Boundary Condition at  $\xi = 0$  :

$$\left. \frac{\partial T}{\partial \xi} \right|_{\xi=0, t+k_j} = - \frac{(x_1 - s)_{t+k_j}}{k_{1, t+k_j}} [(q_{c, net})_{t+k_j} + (\dot{M}_1 \Delta h_c)_{t+k_j} - \epsilon \sigma T_{1, t+k_j}^4] \\ \equiv - Q_{t+k_j} \quad (C.11)$$

where

$$(q_{c, net})_{t+k_j} = [(q_c - \dot{M}_1 n_1 h_e - \dot{M}_2 n_2 h_e) (1 - \frac{h_w}{h_e})]_{t+k_j} \quad (C.12)$$

$\dot{M}_1$  and  $\dot{M}_2$  at  $t = t+k_j$  are computed from formulas given in Appendix

A. Equation C.11 can be written

$$- \frac{\bar{T}_{0, t+k_j} + T_{2, t+k_j}}{2 h_1} = - Q_{t+k_j} \quad (C.13)$$

where the bar on  $\bar{T}_{0, t+k_j}$  denotes a fictitious quantity.

Hence, from (C.13)

$$\bar{T}_{0, t+k_j} = T_{2, t+k_j} + 2 h_1 Q_{t+k_j} \quad (C.14)$$

To eliminate  $\bar{T}_{0, t+k_j}$ , the field equation, (C.7), is applied at  $\xi = 0$ . Note that the derivative  $\frac{\partial k_1}{\partial \xi}$  which appears in the second term of  $g_{1, i, t+k_j}$  in (C.10) is represented by a forward difference operator of  $O(h^2)$  when  $\xi = 0$ , ( $i=1$ ). Thus, from (C.14), and (C.7) applied at  $\xi = 0$ , we have the following boundary condition at  $\xi = 0$ ;

$$\begin{aligned}
& [1+2 \lambda_{1j} f_{1, t+k_j}] T_{1, t+k_j} + [-2 \lambda_{1j} f_{1, t+k_j}] T_{2, t+k_j} \\
& = T_{1, t} + 2 h_1 \lambda_{1j} [f_{1, t+k_j} - \frac{1}{2} h_1 g_{1, t+k_j}] Q_{t+k_j} \quad (C.15)
\end{aligned}$$

The field equation for the insulator:

This is equation 2.10. Defining

$$\lambda_{2j} = k_j / h_2^2 \quad (C.16)$$

$$f_{5, t+k_j} = \frac{k_{5, t+k_j}}{x_5^2 \rho_5 C_{p5, t+k_j}} \quad (C.17)$$

$$g_{5, t+k_j} = \frac{1}{x_5^2 \rho_5 C_{p5, t+k_j}} \left. \frac{\partial k_5}{\partial n} \right|_{i, t+k_j}, \quad (C.18)$$

the finite difference field equation becomes

$$\begin{aligned}
& [-\lambda_{2j} f_{5, t+k_j} + \frac{1}{2} h_2 \lambda_{2j} g_{5, t+k_j}] T_{i-1, t+k_j} + [1+2 \lambda_{2j} f_{5, t+k_j}] T_{i, t+k_j} \\
& + [-\lambda_{2j} f_{5, t+k_j} - \frac{1}{2} h_2 \lambda_{2j} g_{5, t+k_j}] T_{i+1, t+k_j} = T_{i, t} \quad (C.19)
\end{aligned}$$

Interface Condition,  $i=m$ . (the structure is the interface)

This equation was put in finite difference form in three ways:

- 1) forward-backward differences of  $O(h)$ ;
- 2) forward-backward differences of  $O(h^2)$ ;
- 3) central differences of  $O(h^2)$ .

The first formulation is the simplest, and results using it were found to agree closely with results using the second formulation.

The third formulation was found to be unstable at certain structural temperatures and thermal gradients at the interface.

Formulation 1:

$$\begin{aligned}
 & [-h_1 \lambda_{1j} g_{12_{t+k_j}}] T_{m-1,t+k_j} + [1 + h_1 \lambda_{1j} g_{12_{t+k_j}} + h_2 \lambda_{2j} g_{25_{t+k_j}}] T_{m,t+k_j} \\
 & + [-h_2 \lambda_{2j} g_{25_{t+k_j}}] T_{m+1,t+k_j} = T_{m,t}
 \end{aligned} \tag{C.20}$$

where

$$g_{12_{t+k_j}} = \frac{k_{1_{m,t+k_j}}}{x_2 (x_1 - s)_{t+k_j} (\rho_2 C_{p2})_{t+k_j}} \tag{C.21}$$

$$g_{25_{t+k_j}} = \frac{k_{5_{m,t+k_j}}}{x_2 x_5 (\rho_2 C_{p2})_{t+k_j}} \tag{C.22}$$

Formulation 2:

$$\begin{aligned}
 & [\frac{1}{2} h_1 \lambda_{1j} g_{12_{t+k_j}}] T_{m-2,t+k_j} - [2 h_1 \lambda_{1j} g_{12_{t+k_j}}] T_{m-1,t+k_j} \\
 & + [1 + \frac{3}{2} h_1 \lambda_{1j} g_{12_{t+k_j}} + \frac{3}{2} h_2 \lambda_{2j} g_{25_{t+k_j}}] T_{m,t+k_j}
 \end{aligned} \tag{C.23}$$

$$- [2h_2 \lambda_{2j} g_{25_{t+k_j}}] T_{m+1,t+k_j} + [\frac{1}{2} h_2 \lambda_{2j} g_{25_{t+k_j}}] T_{m+2,t+k_j} = T_{m,t}$$

Equation (C.23) can be reduced to a tridiagonal form prior to inversion by elementary row operations applied to it and to the field equations applied on either side of it, i.e., at  $i = m-1$ ,  $i=m+1$ .

Formulation 3:

This formulation is more consistent with the boundary condition at  $\xi = 0$ , than Formulations 1 and 2, since it utilizes the two field equations, and the interface condition, at the interface. Hence, applying eqs. (2.3), (2.5), and (2.10) at  $\xi = 1$ ,  $\eta = 0$ , and eliminating the two fictitious values of temperature, the result is

$$\begin{aligned} & [- \frac{h_1 \lambda_{1j} f_{1_{m,t+k_j}} g_{12_{t+k_j}}}{f_{1_{m,t+k_j}} + \frac{1}{2} h_1 g_{1_{m,t+k_j}}} ] T_{m-1,t+k_j} \\ & + [1 + \frac{1}{2} h_1 g_{12_{t+k_j}} \{ \frac{1 + 2 \lambda_{1j} f_{1_{m,t+k_j}}}{f_{1_{m,t+k_j}} + \frac{1}{2} h_1 g_{1_{m,t+k_j}}} \} \\ & + \frac{1}{2} h_2 g_{25_{t+k_j}} \{ \frac{1 + 2 \lambda_{2j} f_{5_{m,t+k_j}}}{f_{5_{m,t+k_j}} - \frac{1}{2} h_2 g_{5_{m,t+k_j}}} \} ] T_{m,t+k_j} \\ & + [- \frac{h_2 \lambda_{2j} f_{5_{m,t+k_j}} g_{25_{t+k_j}}}{f_{5_{m,t+k_j}} - \frac{1}{2} h_2 g_{5_{m,t+k_j}}} ] T_{m+1,t+k_j} = \end{aligned} \quad (C.24)$$

$$\left[ 1 + \frac{\frac{1}{2} h_1 g_{12,t+k_j}}{f_{1,m,t+k_j} + \frac{1}{2} h_1 g_{1,m,t+k_j}} + \frac{\frac{1}{2} h_2 g_{25,t+k_j}}{f_{5,m,t+k_j} - \frac{1}{2} h_2 g_{5,m,t+k_j}} \right] T_{m,t+k_j}$$

where the quantities  $f_{5i,t+k_j}$  and  $g_{5i,t+k_j}$  are defined by relations similar to (C.9) and (C.10).

This formulation has the disadvantage that, for certain temperatures, one or more of the quantities  $f_{1,m,t+k_j} + \frac{1}{2} h_1 g_{1,m,t+k_j}$ ,  $f_{5,m,t+k_j} - \frac{1}{2} h_2 g_{5,m,t+k_j}$  become small enough that C.24 exhibits instability. Several cases were run using these three formulations with the result that (1) and (2) gave results which were in good agreement. (See Table C.1. The first two entries in this table represent results obtained at Langley using the Langley computer program. "Langley Exact" refers to an analysis, documented in Ref. 33, which includes the consideration of the char layer thickness and the pyrolysis zone location. "Langley Sub" corresponds to an approximate analysis done at Langley which is similar to that programmed at Case). Since formulation (1) is the simpler of the two, it was chosen to be used in subsequent analyses.

Insulator Field Equation:

Run #	Data			Interface Treatment	Output at t = 900 sec.				Remarks
	$x_1$ (ft)	$x_2$ (ft)	$x_5$ (ft)		$T_1$ (°R)	$T_M$ (°R)	$T_N$ (°R)	s(ft)	
Langley Exact	.1875	.0104	.09375	$O(h^3)$ back-forward	1984	556	540	.0667	Run at Langley
Langley Sub-limitation	.1875	.0104	.09375	$O(h^3)$ back-forward	2406	654	546	.0584	Run at Langley
Langley Example	.1875	.0104	.09375	$O(h^2)$ back-forward	2291	641	540	.0587	Case run
L "	.1875	.0104	.09375	$O(h)$ back-forward	2288	664	540	.0586	"
L "	.1875	.01	.09375	$O(h^2)$ central	2288	647	540	.0586	"
7	.15	.01	.09375	$O(h)$ back-forward	2263	1508	542	.0586	diverges
7	.15	.01	.09375	$O(h^2)$ central	2266	1869	542	.0587	
7	.15	.01	.09375	$O(h^2)$ back-forward	2257	1607	542	.0586	
6	.10	.01	.09375	$O(h)$ back-forward	2340	2974	2800	.0586	
6	.10	.01	.09375	$O(h^2)$ back-forward	2380	3047	2975	.0588	
5	.15	.005	.05	$O(h)$ back-forward	2266	1984	1119	.0586	
5	.15	.005	.05	$O(h^2)$ back-forward	2270	1948	1131	.0585	
4	.15	.03	.15	$O(h)$ back-forward	2255	972	540	.0584	
4	.15	.03	.15	$O(h^2)$ back-forward	2258	1029	540	.0586	
4	.15	.03	.15	$O(h^2)$ central	2249	996	540	.0586	
1	.1125	.01	.09375	$O(h^2)$ back-forward	2289	2834	2227	.0586	
1	.1125	.01	.09375	$O(h)$ back-forward	2265	2758	1866	.0585	
1	.1125	.01	.09375	$O(h^2)$ central	diverges before t = 900 sec. is reached.				

TABLE C.1



$$[\lambda_{2j} f_{5_{i,t+k_j}} + \frac{1}{2} \lambda_{2j} h_2 g_{5_{i,t+k_j}}] T_{i-1,t+k_j} \quad (C.25)$$

$$+ [1+2 \lambda_{2j} f_{5_{i,t+k_j}}] T_{i,t+k_j} + [-\lambda_{2j} f_{5_{i,t+k_j}} - \frac{1}{2} h_2 \lambda_{2j} g_{5_{i,t+k_j}}] T_{i+1,t+k_j} = T_{i,t}$$

Backwall Boundary Condition:

$$[-2 \lambda_{2j} f_{5_{n,t+k_j}}] T_{n-1,t+k_j} + [1+2 \lambda_{2j} f_{5_{n,t+k_j}}] T_{n,t+k_j} = T_{n,t} \quad (C.26)$$

## II. Sandwich Sheet Structural Layer

The sandwich structure requires one finite difference station more than the thin sheet structure. The upper (outer) sandwich face is station  $m$ , and the lower (inner) sandwich face is station  $m+1$ . The first station in the insulator is station  $m+2$ . Thus if the panel incorporating a thin sheet structure requires a total of  $n$  stations, that incorporating a sandwich structure requires  $n+1$  stations, if both systems are to have equal numbers of stations in their ablator layers and in their insulation layers.

As in the case of thin sheet, the accuracy of the finite difference approximation used is  $O(h)$ . The interface conditions are:

$$[-h_1 \lambda_{1j} g_{12_{t+k_j}}] T_{m-1,t+k_j} + [1+h_1 \lambda_{1j} g_{12_{t+k_j}} + h_1^2 \lambda_{1j} g_{23_{t+k_j}}] T_{m,t+k_j} \quad (C.27)$$

$$+ [-h_1^2 \lambda_{1j} g_{23_{t+k_j}}] T_{m+1,t+k_j} = T_{m,t}$$

$$[-h_2^2 \lambda_{2j} g_{34_{t+k_j}}] T_{m,t+k_j} + [1+h_2^2 \lambda_{2j} g_{34_{t+k_j}} + h_2 \lambda_{2j} g_{45_{t+k_j}}] T_{m+1,t+k_j} \quad (C.28)$$

$$+ [h_2 \lambda_{2j} g_{45_{t+k_j}}] T_{m+2,t+k_j} = T_{m+1,t}$$

where

$$g_{12_{t+k_j}} = \frac{k_{1,m,t+k_j}}{(x_1 - s)_{t+k_j} x_2 \rho_2 C_{p_2_{t+k_j}}}$$

$$g_{23_{t+k_j}} = \frac{(k_e + k_a)_{t+k_j}}{x_2 x_3 \rho_2 C_{p_2_{t+k_j}}} \quad (C.29)$$

$$g_{34_{t+k_j}} = \frac{(k_e + k_a)_{t+k_j}}{x_3 x_4 \rho_4 C_{p_4_{t+k_j}}}$$

$$g_{45_{t+k_j}} = \frac{k_{5_{m+1,t+k_j}}}{x_4 x_5 \rho_4 C_{p_4_{t+k_j}}}$$

## Summary and Computer Implementation

The programmed thermal analysis equations are C.15, C.7, C.20 (or C.27 and C.28), C.19, and C.26. These can be grouped together in matrix form as

$$[C] \{T\}_{t+k_j} = \{T\}_t \quad (C.30)$$

where C is a tri-diagonal matrix which is a function of heating rate, material properties, and ablation rate at time =  $t+k_j$ . In vector form

$$C \underline{T}_{t+k_j} = \underline{T}_t \quad (C.30a)$$

THE METHOD OF SOLUTION: The thermal distribution at  $t = 0$  is assumed known. The next one is obtained by iteration, based on a guessed distribution, at  $t = k_1$ . At this point, the two known thermal distributions are used in a linear extrapolation to get an approximation for the next one, at  $t = k_1 + k_2$ . From this point, the program works as follows:

At time  $t$ ,  $k_j$  and  $k_{j-1}$  are known, as well as  $\underline{T}_t$  and  $\underline{T}_{t-k_{j-1}}$ . Using this data, compute.

$$\underline{T}'_{t+k_j} = \left(\frac{k_j + k_{j-1}}{k_{j-1}}\right) \underline{T}_t - \left(\frac{k_j}{k_{j-1}}\right) \underline{T}_{t-k_{j-1}} \quad (C.31)$$

Now the C matrix is filled with approximate values, as

$$C = C \{ \text{function of } (\underline{T}'_{t+k_j}) \} \quad (C.32)$$

Then the solution to equation C.30a, which is obtained by elimination and back substitution, is written symbolically as

$$\underline{T}_{t+k_j} = C^{-1} \underline{T}_t \quad (C.33)$$

and a comparison is made, as

$$\max_i | T_{i,t+k_j} - T_{i,t+k_j}^i | < \epsilon \quad (C.34)$$

If condition (C.34) is satisfied then

$\underline{T}_{t+k_j} \leftarrow \underline{T}_{t+k_j}^i$  and the time is incremented. If (C.34) is not satisfied then  $\underline{T}_{t+k_j} \leftarrow \underline{T}_{t+k_j}^f$  and the sequence from (C.32) to (C.34) is repeated. The following flow chart describes the process more completely. (Figure C.3)

When  $t > t_{final}$ , the procedure terminates.

The C matrix in this analysis was taken as a 25 x 25 matrix in all cases with a thin structural layer. It is a 26 x 26 matrix with a sandwich substructure. This is made up of 13 stations in the ablator, and 9 stations in the insulator, 2 exterior boundary stations, and 1 or 2 interface stations.

As demonstrated in the flow chart, the time increments are completely variable. The size of  $k_j = (\Delta t)_t$  is chosen such that succeeding thermal distributions are obtained with a minimum of iteration. This is contrasted with the behavior of  $(\Delta t)_t$  for an explicit analysis, where  $(\Delta t)_t$  is chosen by a stability criterion.

To test the run times of the implicit analysis, an explicit analysis was programmed at Case. The ratio of explicit run time to implicit run time was found to be approximately 3 with Traj. I.

Figure C.4 demonstrates the result of allowing  $k \equiv \Delta t$  to be chosen in a dynamic way, as in the implicit analysis. For comparison,

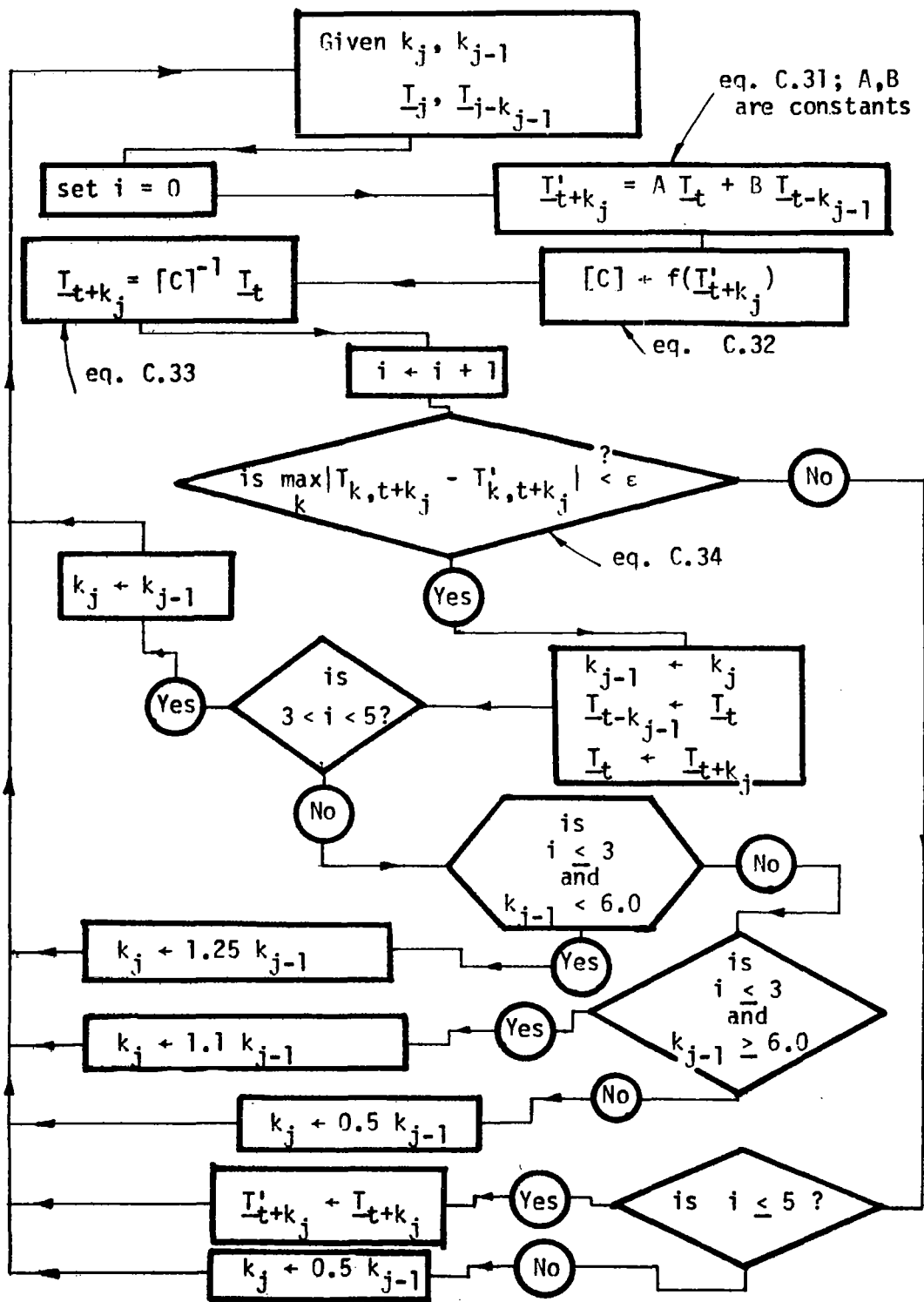

Figure C.3 Flow Chart of Thermal Analysis Loop

the  $\Delta t$ 's used in the explicit analysis (for the exact same test case) are shown. Also, the heating rate of Ref. 15 (Trajectory I) is shown in order to show how the heat input controls the  $(\Delta t)$  size in the implicit case, whereas in the explicit case, the stability criterion exercises stringent control.

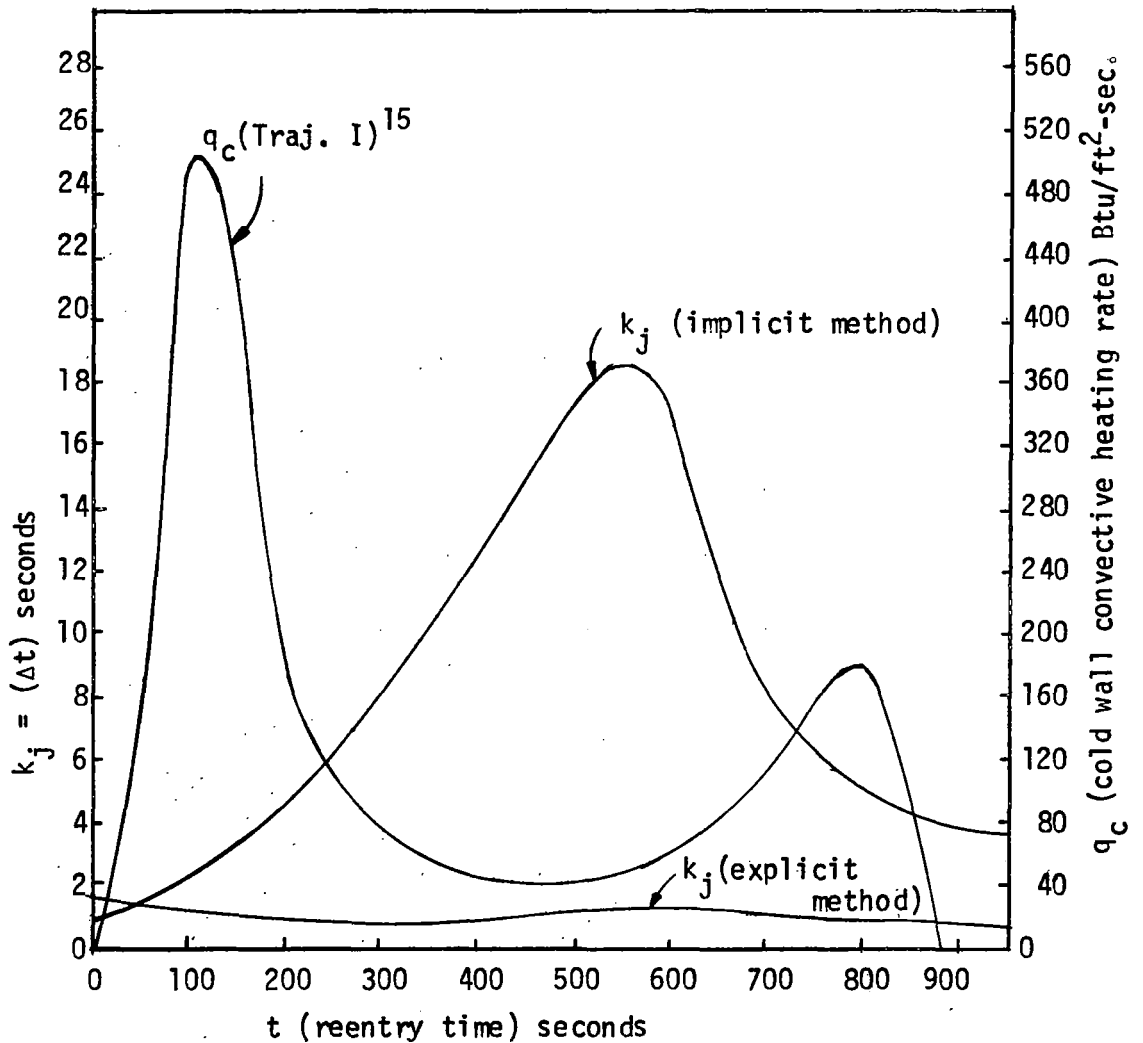

Figure C.4

Run times for the thermal analysis vary with the layer thicknesses and aerodynamic heating. For the 900 sec. re-entry trajectory (Traj. I) , and 25 spatial stations, run times in 1107 Fortran IV average about 22-26 sec. or roughly 1/40 real time. [Since it is known that a Fortran IV program will be executed on an IBM 7094 in about one-half the time it would require on a Univac 1107, it is to be expected that the thermal analysis will be executed in 1/80 of real time for this case.] For the 2400 sec. re-entry path of Traj. II, and 25 spatial stations, 1107 Fortran IV run times average about 27 sec., roughly 1/90 real time.

APPENDIX D  
OPERATION OF THE COMPUTER PROGRAMS

Two separate but highly similar computer programs have been written; one for the thin sheet structural layer, and one for the sandwich structural layer. Both are written in the FORTRAN IV language for use on the Case Univac 1107 computer. Each program requires a core storage capacity of approximately 25,000 words. Run time for a complete synthesis is usually between 1/2 and 3 hours on the Univac 1107. The run time depends on the distance between the initial point and the final optimum point, and upon how close the actual optimum point must be approached. Generally, the closer the optimum is approached, the smaller is the weight (thickness) reduction achieved per unit run time. Hence a trade off of cost of computer time versus desirability of further weight (thickness) reduction would determine the synthesis cut off point.

The following pages explain how to prepare the input data for the programs, and how to interpret the response output. It is assumed that the reader has access to the object programs, either as card decks or as magnetic tapes.

1. Data input and output

Table D.1 contains an alphabetical listing of input and output code names together with explanations and/or reference to the corresponding report name if the latter exists. Most of the input data for a particular case is contained in the arrays which have names ending with "REF".



All of the data which is read into the machine for a particular case is printed out prior to execution of the thermo structural synthesis program. Table D.2 contains a sample data printout for a thin sheet substructure case, consisting of low density phenolic nylon ablator material, aluminum substructure, and microquartz insulation, subjected to trajectory II (see Chapter 4 for a description of the reentry trajectories used). Table D.3 shows a sample data printout for a sandwich substructure case, with low density phenolic nylon ablator, fiberglass sandwich, and microquartz insulation) subjected to trajectory I. These input data printouts allow the data to be checked for accuracy before a significant amount of computer time is used. If errors are found, the run can be promptly terminated.

Data, as it is actually punched on cards for input to the object program, is shown in Tables D.4 and D.5. These tables contain explanatory "COMMENT" cards, each with a "C" in column 1, which must be eliminated from the deck before loading time. They are used here only to clarify the data presentation. The data of Table D.4 corresponds to the same case presented in Table D.2, i.e. Trajectory II, LDPN ablator, aluminum thin sheet substructure, and microquartz insulation. The data of Table D.5 corresponds to that of Table D.3, i.e.; Trajectory I, LDPN ablator, fiberglass sandwich substructure, and microquartz insulation.

## 2. Interpretation of response output

Tables D.6 and D.7 each contain a page of typical response output, the first for the thin sheet substructure and the second for the sandwich sheet substructure. Each contains all the pertinent information about the response of the system under the transient loading at the current design point,  $\underline{x}$ . A page similar to that in either Table D.6 or Table D.7 is printed out for the initial design point, and at the conclusion of each one-dimensional minimization subsequently completed. If the one-dimensional minimization locates a new design point which is more optimum than the current design point, the one-dimensional minimization is successful and the new design point becomes the current design point. In this case, the words "XEM" and "FEM" are printed out immediately following the page which is similar to that in Table D.6 or D.7. If no new point of improved merit is found via the one dimensional search, the word "SKIP" is printed out, and the value of R is incremented. When convergence is obtained for a particular value of R, the words "CONVERGENCE HAS BEEN OBTAINED" will be printed out, followed by the R value for which convergence was obtained, the value of the current move size, "T", and an estimate of the amount by which the current value of  $P(\underline{x},r)$  exceeds its minimum (optimum) value  $P_m$ . When the synthesis is completed, the sentence "THE SYNTHESIS IS COMPLETE" will be printed out. When this occurs, the optimum design point and associated behavior information is given in the page, similar to either Table D.6 or Table D.7, which immediately precedes the last occurring print-out of "XEM" and "FEM".

### 3. Automatic program stops

The program will automatically terminate under certain conditions. When this happens, a sentence will be printed out to give the operator an idea of where the trouble is located. The following are the output captions and their explanations

a) "TEMPERATURE TOO LARGE. PROGRAM TERMINATED FROM THE PROPERTIES SECTION OF SUBROUTINE THRML"

A temperature somewhere in the system has exceeded the maximum temperature for which material properties are recorded in the material reference matrices (MAREF, MSREF, etc.).

b) "BB/T(1,K)"

This cryptic quantity is the exponent of the exponential (e) and will be printed out whenever  $BB/T(1,K) > 88.028$ . The program will not always terminate because the value 88.028 sometimes legitimately occurs. If the program does terminate, look for bad data associated with the ablation analysis (rate constants for carbon oxidation in particular).

c) "THE INITIAL DESIGN POINT IS UNACCEPTABLE"

Try a new starting point. Also, this sometimes occurs after the value of R has been incremented. At this point, the design process behaves as though the program were just started. The current design point is treated as though it were an initial point (as far as the Fletcher-Powell method is concerned it is an initial point because, with the change in R, the character of the design space has changed, and the H matrix must be re-initialized as a unit matrix or other symmetric positive definite matrix). Thus,

although as part of the previous one-dimensional minimization the current design point has been completely analyzed and found to be acceptable, when it is reanalyzed as part of the next R cycle, it is found unacceptable. This is due to slight variations in the design variables caused by multiplying and dividing them by internal scale factors, and it occurs only when one or more the behavior functions is extremely close to zero. When this happens, the operator has two choices of action: (1) Change the design variables slightly to get an acceptable point, and continue, or (2) quit and either call the current point the optimum, or, since this point is somewhat compromised by the fact that it is so critical, back off to the result of the previous successful one-dimensional minimization, i.e., go back to the design just preceding the next to last occurrence of "XEM" and "FEM".

d) "THE ARRAY (TSTOR) RESERVED FOR THE THERMAL PROFILE STORAGE IS TOO SMALL".

Printout of this sentence will be immediately preceded by printout of the integer ITM. The maximum value of ITM is 200. This is also the number of columns permitted in the array TSTOR. When  $ITM > 200$ , the above sentence will be printed out. To correct the situation, either (1) make DTIM larger, which reduces the number of profiles which must be stored, or (2) increase the size of the array TSTOR. This latter change requires alteration of the object program, while the former change can be accomplished by a change in input data.

TABLE D.1  
INPUT/OUTPUT CODE NAMES

Code Name	Description and/or report name
AA	A
BB	B
CE	$C_e$
CELDIA	$d_{cell}$
DHC	$\Delta h_c$
DTIM	Minimum time interval between successive structural analyses.
DX(7)*	Finite difference increments for design variables used in calculation of gradient to $P(\underline{x}, r)$ . DX(1) is the increment of $x(1)$ , DX(2) increment of $x(2)$ , etc.. Refer to $x(7)$ .
EPS	$\epsilon$ ; Emissivity of ablator surface.
ETA1	$\eta_1$ ; blocking effectiveness coefficient
ETA2	$\eta_2$ ; blocking effectiveness coefficient
FEM	This name is associated with the value attained by $P(\underline{x}, r)$ after the successful completion of a one-dimensional minimization.
FIX	Program control integer: FIX equal to 0 means $x_6$ is not fixed; FIX equal to 1 means that $x_6$ has a value which is not changed in the synthesis.
GRN	Greatest real number permitted. Usually equal to $1 \times 10^{30}$
HWREF(R2)	Reference matrix of wall enthalpy values.
ITM	Number of structural analyses executed in the course of a single reentry. Must be equal to or less than 200.

-----  
\* The array dimensions given are those required at input time.

TABLE D.1 (Continued)

Code Name	Description and/or report name
L	Number of separate trajectories considered. Gives number of file entries in LDREF. (Only L = 1 is permitted in current programs.)
LAM	$\lambda$ ; ablation parameter
LD(10)	Loading matrix at current run time. The entries are: <ul style="list-style-type: none"> <li>LD(1); current time (sec.)</li> <li>LD(2); QC, hot wall convective heating (Btu/ft<sup>2</sup>-sec).</li> <li>LD(3); QR, radiative heating rate (Btu/ft<sup>2</sup>-sec)</li> <li>LD(4); velocity (ft/sec)</li> <li>LD(5); free stream density (lbs/ft<sup>3</sup>)</li> <li>LD(6); free stream pressure (in. of hg)</li> <li>LD(7); enthalpy at outer edge of boundary (Btu/lb)</li> <li>LD(8); dynamic pressure (atm)</li> <li>LD(9); free stream pressure (atm)</li> <li>LD(10); enthalpy at wall (Btu/lb)</li> </ul>
LDREF(R1,7,L)	Reference matrix of trajectory dependent thermal and mechanical loadings. The column entries are: <ol style="list-style-type: none"> <li>1) TMREF; time from beginning of trajectory (sec)</li> <li>2) QCREF; hot wall convective heating rate (Btu/ft<sup>2</sup>sec)</li> <li>3) QRREF; radiative heating rate (Btu/ft<sup>2</sup>-sec)</li> <li>4) VELREF; vehicle velocity (ft/sec)</li> <li>5) RHOREF; free stream density (lbs/cu.ft)</li> <li>6) PREF; free stream pressure (in. of hg)</li> <li>7) if PCALC = 0; PDYNREF; dynamic wall pressure (lbs/ft<sup>2</sup>) if PCALC = 1; ALTITUDE (ft)</li> </ol>
M	m; Thermal analysis finite difference station number corresponding to the structural layer (thin sheet) or to the upper sandwich face (sandwich case).

TABLE D.1 (Continued)

Code Name	Description and/or report name
MAREF(R2,10)	<p>Reference matrix of thermal and mechanical properties for the ablator. The column entries are:</p> <ol style="list-style-type: none"> <li>1) TREF; ref. temperature (<math>^{\circ}\text{R}</math>)</li> <li>2) KA; conductivity (Btu/ft-sec <math>^{\circ}\text{R}</math>)</li> <li>3) CPA; specific heat (Btu/lb-<math>^{\circ}\text{R}</math>)</li> <li>4) ETA; Young's modulus-tension (ksi)</li> <li>5) ECA; Young's modulus-compression (ksi)</li> <li>6) STUA; Yield strength-tension (ksi)</li> <li>7) EPSTUA; Ultimate strain-tension</li> <li>8) SCUA; Yield strength-compression</li> <li>9) EPSCUA; Ultimate strain-compression</li> <li>10) ALPHAA; Coefficient of linear thermal expansion (<math>1/^{\circ}\text{R}</math>).</li> </ol>
MCREF(R2,6)	<p>Reference matrix of thermal and mechanical properties for the sandwich core. The column entries are:</p> <ol style="list-style-type: none"> <li>1) TREF; ref. temperature (<math>^{\circ}\text{R}</math>)</li> <li>2) KCORE; conductivity of core material (Btu/ft-sec-<math>^{\circ}\text{R}</math>)</li> <li>3) KAIR; conductivity of air in core (Btu/ft-sec-<math>^{\circ}\text{R}</math>)</li> <li>4) EMISSIVITY; emissivity of core material</li> <li>5) G; shear modulus (Ksi)</li> <li>6) SZXU; Yield stress-shear (Ksi)</li> </ol>
MSREF(R2,5)	<p>Reference matrix of thermal and mechanical properties for the structure (if sandwich, this matrix applies to the upper face). The column entries are:</p> <ol style="list-style-type: none"> <li>1) TREF; ref. temperature (<math>^{\circ}\text{R}</math>)</li> <li>2) CPS; specific heat (Btu/lb-<math>^{\circ}\text{R}</math>)</li> <li>3) ES; Young's modulus (Ksi)</li> <li>4) SUS; Yield strength (Ksi)</li> <li>5) ALPHAS; coefficient of linear thermal expansion (<math>1/^{\circ}\text{R}</math>)</li> </ol>
M4REF(R2,5)	<p>Reference matrix of thermal and mechanical properties for the lower sandwich face. The column entries are the same as for MSREF.</p>

TABLE D.1 (Continued)

Code Name	Description and/or report name
MIREF(R2,3)	Reference matrix of thermal properties for the insulator. The column entries are: 1) TREF; ref. temperature ( $^{\circ}\text{R}$ ) 2) KI; conductivity (Btu/ft-sec. $^{\circ}\text{R}$ ) 3) CPI; specific heat Btu/(lb- $^{\circ}\text{R}$ )
N	n; Thermal analysis finite difference station corresponding to the back wall of the insulator.
NDV	Number of design variables. Gives the dimensionality of the design space. The following values are possible: 1) Sandwich substructure case; a) NDV = 6 if FIX = 0 and $x_2 \neq x_4$ b) NDV = 5 if FIX = 1 and $x_2 \neq x_4$ c) NDV = 5 if FIX = 0 and $x_2 = x_4$ d) NDV = 4 if FIX = 1 and $x_2 = x_4$ 2) Thin sheet substructure case; a) NDV = 4 if FIX = 0 b) NDV = 3 if FIX = 1
PCALC	Program control integer: PCALC = 0 means that the values for dynamic wall pressure (pw) enter the program as input data. For this purpose the last column of LDREF is used. PCALC = 1 means that the dynamic wall pressure is calculated internal to the program using the vehicle velocity and atmospheric density information. In this case the last column of LDREF is filled with ALTITUDE values.
PRAT	Ratio of dynamic wall pressure at a vehicle location other than the stagnation point to the dynamic wall pressure at the stagnation point.
QRAT	Ratio of heating rate at a vehicle location other than the stagnation point to the heating rate at the stagnation point.
RI	Number of discrete trajectory times required to define adequately the trajectory. Gives number of row entries for LDREF.



TABLE D.1 (Continued)

Code Name	Description and/or report name
R2	Number of discrete temperature levels required to describe adequately the material properties. Gives the number of row entries for MAREF, MSREF, MCREF, M4REF, MIREF, and HWREF.
R	$r$ : Initial value of $r$ for the Fiacco-McCormick function.
RHOC	$\rho_3$ : core density (lbs/ft <sup>3</sup> )
RHOI	$\rho_5$ : insulator density (lbs/ft <sup>3</sup> )
RHOS	$\rho_2$ : structural density or upper sandwich face density (lbs/ft <sup>3</sup> )
RHO4	$\rho_4$ : lower sandwich face density (lb/ft <sup>3</sup> )
RHOAC	density of char. (lbs/ft <sup>3</sup> )
RHOAVP	$\rho_1$ : density of virgin ablator material (lbs/ft <sup>3</sup> )
SIGMA	$\sigma$ : Stephan-Boltzman constant
SR	$\Delta A/A$ : core solidity ratio
T	Estimated distance to the minimum along the current travel direction from current design point.
TBMAX	$\bar{T}_B$ : maximum backwall temperature (°R)
TSMAX	$\bar{T}_S$ : maximum structural temperature (°R)
TCURE	$T_0$ : panel cure temperature (°R)
TDMAX	Maximum allowable panel thickness (ft). By choosing an upper limit of TDMAX which is smaller than the thickness obtained from weight minimization, and then again minimizing weight subject to TDMAX as an additional side constraint, weight-thickness trade off studies can be made.
TINT(N)	initial temperature profile (°R)
TPLAS	temperature above which the ablator mechanical strength vanishes (°R)

TABLE D.1 (Continued)

Code Name	Description and/or report																
WGT	Program control integer. WGT = 1 means that minimum weight is the objective; WGT = 0 means that minimum thickness is the objective.																
WMAX	$\bar{w}$ ; maximum allowable panel midpoint deflection (ft)																
WSUP	$w_{sup}$ ; weight per unit panel perimeter of the panel support system																
X(7)	$\underline{x}$ ; vector of design variables (ft). The entries are: <table border="0" style="margin-left: 40px;"> <thead> <tr> <th>Sandwich case</th> <th>Thin Case</th> </tr> </thead> <tbody> <tr> <td>1) <math>x_1</math></td> <td>1) <math>x_1</math></td> </tr> <tr> <td>2) <math>x_2</math></td> <td>2) <math>x_2</math></td> </tr> <tr> <td>3) <math>x_3</math></td> <td>3) <math>x_5</math></td> </tr> <tr> <td>4) <math>x_4</math></td> <td>4) <math>x_6</math></td> </tr> <tr> <td>5) <math>x_5</math></td> <td>5) 0</td> </tr> <tr> <td>6) <math>x_6</math></td> <td>6) 0</td> </tr> <tr> <td>7) 0</td> <td>7) 0</td> </tr> </tbody> </table> <p>Note that the above entries pertain even when <math>x_2 = x_4</math> in the sandwich case, and when <math>x_6</math> is a constant. The rearrangement to account for these various situations is accomplished internally.</p>	Sandwich case	Thin Case	1) $x_1$	1) $x_1$	2) $x_2$	2) $x_2$	3) $x_3$	3) $x_5$	4) $x_4$	4) $x_6$	5) $x_5$	5) 0	6) $x_6$	6) 0	7) 0	7) 0
Sandwich case	Thin Case																
1) $x_1$	1) $x_1$																
2) $x_2$	2) $x_2$																
3) $x_3$	3) $x_5$																
4) $x_4$	4) $x_6$																
5) $x_5$	5) 0																
6) $x_6$	6) 0																
7) 0	7) 0																
XEM	Gives the scaled design point now occupied as the result of a successfully completed one-dimensional minimization.																
XMAX(7)	Upper side constraints on the design variables (ft). The entries parallel those for X(7) above.																
XMIN(7)	Lower side constraints on the design variables (ft). Again, the entries parallel those given for X(7) above.																
CC	C: Reduction factor used in Fiacco-McCormick Function ( $r_{i+1} = r_i/c$ ).																

DATA FOR AEROTHERMOELASTIC PANEL SYNTHESIS PROGRAM

NUMNER OF FINITE DIFFERENC F STATIONS IN ABLATOR=M= 15  
 TOTAL NUMBER OF FINITE DIFFERENCE STATIONS=N= 25  
 NUMBER OF TIME REFERENCE VALUES=R1= 17  
 NUMBER OF TEMP. REFERENCE VALUES=R2= 15  
 NUMBER OF REENTRY PATHS CONSIDERED=L= 1  
 THE NUMBER OF DESIGN VARIABLES=NDV= 4

LAM= 1.8750  
 RHOS= 172.80 LBS/CUBIC FOOT  
 ETA2= .60  
 RB= .400+05  
 EPS= .80  
 CE= .232  
 RHOAC= 20.00 LBS/CUBIC FOOT  
 TBMAX= 660.00 DEGREES RANKINE

RHOI= 6.00 LBS/CUBIC FOOT  
 ETA1= .60  
 AA= .447+05  
 SIGMA= .480-12 BTU/SQ-FT\*SEC\*(R\*\*4)  
 DHC= 2000.0 BTU/LB  
 RHOAVP= 36.00 LBS/CUBIC FOOT  
 TSMAX= 1200.00 DEGREES RANKINE  
 WMAX= .020 FEET

THE ALLOWABLE TOTAL WALL THICKNESS IS .10000+01 FT.  
 THE WEIGHT OF THE PANEL SUPPORT SYSTEM PER FOOT OF PERIMETER IS .10000+01 LBS.  
 THE GREATEST REAL NUMBER IS .10000+32

TCURE= .81000+03 DEGREES R  
 TPLAS= .90000+03 DEGREES R  
 DTIM= .10000+02 SEC.  
 GRAT= .10000+01  
 PRAT= .10000+01  
 CC= 100.00  
 FIX= 0  
 WGT= 1  
 PCALC= 0

THE INITIAL TEMPERATURE DISTRIBUTION (TINT) IS

.5400+03	.5400+03	.5400+03	.5400+03	.5400+03	.5400+03	.5400+03	.5400+03	.5400+03	.5400+03	.5400+03
.5400+03	.5400+03	.5400+03	.5400+03	.5400+03	.5400+03	.5400+03	.5400+03	.5400+03	.5400+03	.5400+03
.5400+03	.5400+03	.5400+03	.5400+03	.5400+03	.5400+03	.5400+03	.5400+03	.5400+03	.5400+03	.5400+03

THE INITIAL VALUE OF R IS .100-01  
 THE FIRST GUESS MOVE LENGTH=T= .50000-02

THE INITIAL DESIGN POINT IS .25000 .00520 .15000 1.00000 .00000 .00000 .00000

LOWER ROUNDS ON THE DESIGN VARIABLES ARE

.10000+00	.10000-02	.10000-01	.50000-00	.00000	.00000	.00000
-----------	-----------	-----------	-----------	--------	--------	--------

UPPER ROUNDS ON THE DESIGN VARIABLES ARE

.40000-00	.20000-01	.20000-00	.30000+01	.00000	.00000	.00000
-----------	-----------	-----------	-----------	--------	--------	--------

THE COORDINATE INCREMENTS ARE

.10000-01	.10000+00	.20000-00	.50000-01	.00000	.00000	.00000
-----------	-----------	-----------	-----------	--------	--------	--------

Table D.2 Sample Data Printout: Traj. II, LDPN ablator, aluminum thin sheet structure, microquartz insulation

THE REFERENCE MATRIX OF TRAJECTORY DEPENDENT THERMAL AND MECHANICAL LOADINGS (LDREF)

NO.	TMREF SECONDS	QCREF BTU/SQ-FT-SEC	QRREF BTU/SQ-FT-SEC	VELREF FT/SEC	RHOREF LBS/CU-FT	PREF IN.OF HG.	PDYNREF LBS/SQ-FT.
1.	.00	.00	.00	26500.0	.11640-08	.00000	.0
2	50.00	2.50	.00	26500.0	.45610-08	.00000	20.0
3	125.00	10.00	.00	26500.0	.23790-07	.00000	110.0
4	187.00	20.00	5.00	26500.0	.14880-06	.00000	100.0
5	250.00	40.00	7.50	26500.0	.61710-06	.00000	95.0
6	325.00	72.00	7.00	26500.0	.16300-05	.00000	80.0
7	500.00	62.00	6.00	26000.0	.16300-05	.00000	60.0
8	750.00	58.00	5.00	25500.0	.16300-05	.00000	50.0
9	875.00	56.00	4.80	25000.0	.16300-05	.00000	50.0
10	1000.00	61.00	4.50	24000.0	.16300-05	.00000	50.0
11	1250.00	78.00	3.00	22000.0	.65980-05	.00000	45.0
12	1375.00	80.00	2.50	20000.0	.97390-05	.00000	40.0
13	1500.00	70.00	2.40	18000.0	.16960-04	.00000	40.0
14	1750.00	48.00	1.00	14000.0	.35560-04	.00000	40.0
15	2000.00	23.00	.00	10000.0	.74710-04	.00000	40.0
16	2250.00	5.00	.00	5000.0	.33010-03	.00000	30.0
17	2400.00	.00	.00	.0	.76470-01	.00000	10.0

Table D.2 (Continued)

THE REFERENCE MATRIX OF THERMAL AND MECHANICAL PROPERTIES FOR THE ABLATOR (MAREF)

NO.	TREF DEGREES R	KA BTU/FT-SEC-R	CPA BTU/LB-R	ETA KSI	ECA KSI	STUA KSI	EPSTUA	SCUA KSI	EPSCUA	ALPHAA 1/R
1	360.0	.180-04	.240-00	160.0	240.0	1.3	.00870	5.08	.02500	.200-04
2	460.0	.200-04	.300-00	140.0	160.0	1.2	.00950	5.00	.04600	.300-04
3	560.0	.210-04	.360-00	100.0	110.0	1.1	.01600	3.70	.08000	.300-04
4	700.0	.210-04	.440-00	35.0	55.0	.7	.04500	3.00	.79000	.000
5	800.0	.210-04	.500-00	12.0	45.0	.3	.06000	2.70	.20000	.000
6	1000.0	.300-04	.600-00	3.0	12.0	.1	.05000	.50	.20000	-.300-04
7	1195.0	.400-04	.700-00	.0	6.0	.0	.07000	.06	.20000	-.300-04
8	1200.0	.400-04	.270+01	.0	6.0	.0	.07000	.00	1.00000	-.300-04
9	1400.0	.450-04	.280+01	.0	.0	.0	1.00000	.00	1.00000	-.400-04
10	1405.0	.450-04	.800-00	.0	.0	.0	1.00000	.00	1.00000	-.400-04
11	1460.0	.460-04	.800-00	.0	.0	.0	1.00000	.00	1.00000	-.400-04
12	2460.0	.290-03	.800-00	.0	.0	.0	1.00000	.00	1.00000	-.400-04
13	3460.0	.700-03	.800-00	.0	.0	.0	1.00000	.00	1.00000	-.400-04
14	3900.0	.100-02	.800-00	.0	.0	.0	1.00000	.00	1.00000	-.400-04
15	7000.0	.100-02	.800-00	.0	.0	.0	1.00000	.00	1.00000	-.400-04

Table D.2 (Continued)

THE REFERENCE MATRIX OF THERMAL AND MECHANICAL PROPERTIES FOR THE BACK-UP SHEET (MSREF)

NO.	TREF DEGREES R	CPS BTU/LR-R	ES KSI	SUS KSI	ALPHAS 1/R
1	360.0	.175-00	.114+05	45.0	.120-04
2	460.0	.195-00	.107+05	45.0	.120-04
3	560.0	.215-00	.102+05	45.0	.120-04
4	700.0	.225-00	.101+05	41.0	.120-04
5	800.0	.230-00	.980+04	38.0	.120-04
6	1000.0	.240-00	.790+04	18.0	.130-04
7	1195.0	.265-00	.570+04	6.8	.140-04
8	1200.0	.266-00	.550+04	6.7	.140-04
9	1400.0	.305-00	.000	.0	.150-04
10	1405.0	.306-00	.000	.0	.150-04
11	1460.0	.325-00	.000	.0	.150-04
12	2460.0	.325-00	.000	.0	.150-04
13	3460.0	.325-00	.000	.0	.150-04
14	3900.0	.325-00	.000	.0	.150-04
15	7000.0	.325-00	.000	.0	.150-04

Table D.2 (Continued)

THE REFERENCE MATRIX OF THERMAL AND MECHANICAL PROPERTIES FOR THE INSULATOR (MIREF)

NO.	TREF DEG. R	KI BTU/FT-SEC-R	CPI BTU/LB-R
1	360.0	.450-05	.400-00
2	460.0	.750-05	.400-00
3	560.0	.830-05	.400-00
4	700.0	.103-04	.400-00
5	800.0	.117-04	.400-00
6	1000.0	.400-04	.400-00
7	1195.0	.400-04	.400-00
8	1200.0	.400-04	.400-00
9	1400.0	.450-04	.400-00
10	1405.0	.450-04	.400-00
11	1460.0	.460-04	.400-00
12	2460.0	.290-03	.400-00
13	3460.0	.700-03	.400-00
14	3900.0	.100-02	.400-00
15	7000.0	.100-02	.400-00

Table D.2 (Continued)

## THE REFERENCE MATRIX OF WALL ENTHALPY VALUES

NO.	TREF DEG. R	HW BTU/LB
1	360.0	.69400+02
2	460.0	.10120+03
3	560.0	.13300+03
4	700.0	.16860+03
5	800.0	.19400+03
6	1000.0	.24210+03
7	1195.0	.29000+03
8	1200.0	.29300+03
9	1400.0	.34300+03
10	1405.0	.34600+03
11	1460.0	.36400+03
12	2460.0	.64500+03
13	3460.0	.95000+03
14	3900.0	.11400+04
15	7000.0	.18000+04

Table D.2 (Concluded)



DATA FOR AEROTHERMOELASTIC PANEL SYNTHESIS PROGRAM

NUMBER OF FINITE DIFFERENCE STATIONS IN ABLATOR=M= 15  
 TOTAL NUMBER OF FINITE DIFFERENCE STATIONS=N= 26  
 NUMBER OF TIME REFERENCE VALUES=R1= 25  
 NUMBER OF TEMP. REFERENCE VALUES=R2= 15  
 NUMBER OF REENTRY PATHS CONSIDERED=L= 1  
 THE NUMBER OF DESIGN VARIABLES=NDV= 5

LAM= 1.8750  
 RHOS= 110.00LBS/CUBIC FOOT  
 ETA2= .60  
 RB= .400+05  
 EPS= .80  
 CE= .232  
 RHOAC= 20.00LBS/CUBIC FOOT  
 TBMAX= 660.00DEGREES RANKINE  
 RHOI= 6.00LBS/CURIC FOOT  
 ETA1= .60  
 AA= .447+05  
 SIGMA= .480-12BTU/SQ-FT\*SEC\*(R\*\*4)  
 DHC= 2000.0BTU/LB  
 RHOAVP= 36.00LBS/CUBIC FOOT  
 TSMAX= 1200.00DEGREES RANKINE  
 WMAX= .020FEET

THE ALLOWABLE TOTAL WALL THICKNESS IS .10000+01 FT.  
 THE WEIGHT OF THE PANEL SUPPORT SYSTEM PER FOOT OF PERIMETER IS .10000+01 LBS.  
 THE GREATEST REAL NUMBER IS .10000+32  
 THE DENSITY OF THE CORE(RHOC)IS .60000+01 LBS/CU.FT.  
 THE CORE CELL DIAMETER(CELDIA)IS .20800-01 FT.  
 THE CORE SOLIDITY RATIO (SR) IS .10000+00  
 THE DENSITY OF THE LOWER SANDWICH FACE (RH04) IS .11000+03 LBS/CU.FT.  
 TCURE= .81000+03 DEGREES R  
 TPLAS= .90000+03 DEGREES R  
 NTIM= .50000+01 SEC.  
 GRAT= .10000+01  
 PRAT= .10000+01  
 CC= 100.00  
 FIX= 0  
 WGT= 0  
 PCALC= 1

THE INITIAL TEMPERATURE DISTRIBUTION (TINT) IS

.5400+03	.5400+03	.5400+03	.5400+03	.5400+03	.5400+03	.5400+03	.5400+03	.5400+03	.5400+03
.5400+03	.5400+03	.5400+03	.5400+03	.5400+03	.5400+03	.5400+03	.5400+03	.5400+03	.5400+03
.5400+03	.5400+03	.5400+03	.5400+03	.5400+03	.5400+03	.5400+03	.5400+03	.5400+03	.5400+03

THE INITIAL VALUE OF R IS .100-07  
 THE FIRST GUESS MOVE LENGTH=T= .10000-02

THE INITIAL DESIGN POINT IS .16773 .01301 .03625 .01301 .02144 .56138 -.00000  
 LOWER BOUNDS ON THE DESIGN VARIABLES ARE  
 .10000+00 .10000-02 .31250-01 .10000-02 .10000-01 .50000-00 .00000  
 UPPER BOUNDS ON THE DESIGN VARIABLES ARE  
 .40000-00 .40000-01 .30000-00 .40000-01 .20000-00 .30000+01 .10000+02

THE COORDINATE INCREMENTS ARE  
 .10000-01 .10000-01 .10000-01 .10000-01 .20000-01 .10000-01 .00000

Table D.3 Sample Data Printout: Traj. I, LDPN ablator, fiberglass, sandwich structure, microquartz insulator

THE REFERENCE MATRIX OF TRAJECTORY DEPENDENT THERMAL AND MECHANICAL LOADINGS (LDREF)

NO.	TMREF SECONDS	OCREF BTU/SQ-FT-SEC	BTU/SEC	VELREF FT/SEC	RHOREF LBS/CUFT	PREF IN.OF HG.	ALTITUDE FEET
1	.00	.00	.00	37000.0	.11640-08	.63050-06	40000.0
2	50.00	200.00	60.00	37000.0	.12460-04	.30550-03	262500.0
3	100.00	500.00	310.00	35000.0	.16960-04	.58460-02	200000.0
4	130.00	400.00	170.00	31000.0	.20470-04	.71400-02	195000.0
5	170.00	240.00	30.00	25700.0	.11750-04	.38790-02	210000.0
6	200.00	170.00	15.00	26500.0	.80300-05	.25230-02	220000.0
7	250.00	100.00	5.00	25500.0	.16350-05	.99550-03	240000.0
8	300.00	60.00	.00	25000.0	.12460-05	.30550-03	262500.0
9	350.00	40.00	.00	25000.0	.46610-06	.11430-03	280000.0
10	400.00	30.00	.00	25000.0	.26600-06	.65240-04	290000.0
11	450.00	25.00	.00	25000.0	.14880-06	.37370-04	300000.0
12	500.00	25.00	.00	25000.0	.14880-06	.37370-04	300000.0
13	550.00	30.00	.00	24900.0	.26600-06	.65240-04	290000.0
14	600.00	40.00	.00	24800.0	.40510-06	.99370-04	282500.0
15	650.00	60.00	.00	24500.0	.10820-05	.26550-03	265000.0
16	700.00	.00	.00	24000.0	.35350-05	.99550-03	240000.0
17	725.00	115.00	.00	23800.0	.65980-05	.20180-02	225000.0
18	750.00	135.00	.00	23000.0	.11750-04	.38790-02	210000.0
19	800.00	162.00	.00	22000.0	.49260-04	.18100-01	171000.0
20	800.00	175.00	.00	20000.0	.66680-04	.24980-01	162500.0
21	820.00	120.00	.00	16300.0	.16990-03	.59470-01	140000.0
22	840.00	70.00	.00	11500.0	.41510-03	.13570-00	120000.0
23	860.00	35.00	.00	6500.0	.10670-02	.32900-00	100000.0
24	880.00	.00	.00	3300.0	.30080-02	.90850-00	78000.0
25	900.00	.00	.00	1500.0	.57160-02	.16820+01	65000.0

Table D.3 (Continued)

THE REFERENCE MATRIX OF THERMAL AND MECHANICAL PROPERTIES FOR THE ABLATOR (MAREF)

NO.	TREF DEGREES R	KA BTU/FT-SEC-R	CPA BTU/LB-R	ETA KSI	ECA KSI	STUA KSI	EPSTUA	SCUA KSI	EPSCUA	ALPHAA 1/R
1	360.0	.180-04	.240-00	160.0	240.0	1.3	.00870	5.08	.02500	.200-04
2	460.0	.200-04	.300-00	140.0	160.0	1.2	.00950	5.00	.04600	.300-04
3	560.0	.210-04	.360-00	100.0	110.0	1.1	.01600	3.70	.08000	.300-04
4	700.0	.210-04	.440-00	35.0	55.0	.7	.04500	3.00	.79000	.000
5	800.0	.210-04	.500-00	12.0	45.0	.3	.06000	2.70	.20000	.000
6	1000.0	.300-04	.600-00	3.0	12.0	.1	.05000	.50	.20000	-.300-04
7	1195.0	.400-04	.700-00	.0	6.0	.0	.07000	.06	.20000	-.300-04
8	1200.0	.400-04	.270+01	.0	6.0	.0	.07000	.00	1.00000	-.300-04
9	1400.0	.450-04	.280+01	.0	.0	.0	1.00000	.00	1.00000	-.400-04
10	1405.0	.450-04	.800-00	.0	.0	.0	1.00000	.00	1.00000	-.400-04
11	1460.0	.460-04	.800-00	.0	.0	.0	1.00000	.00	1.00000	-.400-04
12	2460.0	.290-03	.800-00	.0	.0	.0	1.00000	.00	1.00000	-.400-04
13	3460.0	.700-03	.800-00	.0	.0	.0	1.00000	.00	1.00000	-.400-04
14	3900.0	.100-02	.800-00	.0	.0	.0	1.00000	.00	1.00000	-.400-04
15	7000.0	.100-02	.800-00	.0	.0	.0	1.00000	.00	1.00000	-.400-04

Table D.3 (Continued)

THE REFERENCE MATRIX OF THERMAL AND MECHANICAL PROPERTIES FOR THE UPPER SANDWICH FACE (MSHEF)

NO.	TREF DEGREES R	CPS BTU/LB-R	ES KSI	SUS KSI	ALPHAS 1/R
1	360.0	.190-00	.330+04	20.0	.510-05
2	460.0	.200-00	.330+04	20.0	.510-05
3	560.0	.210-00	.320+04	15.0	.510-05
4	700.0	.240-00	.300+04	13.0	.500-05
5	800.0	.270-00	.290+04	15.0	.450-05
6	1000.0	.280-00	.280+04	14.0	.400-05
7	1195.0	.300-00	.220+04	18.0	.350-05
8	1200.0	.300-00	.220+04	18.0	.350-05
9	1400.0	.300-00	.500+03	11.0	.300-05
10	1405.0	.300-00	.500+03	11.0	.300-05
11	1460.0	.300-00	.100+03	4.0	.300-05
12	2460.0	.300-00	.000	.0	.300-05
13	3460.0	.300-00	.000	.0	.300-05
14	3900.0	.300-00	.000	.0	.300-05
15	7000.0	.300-00	.000	.0	.300-05

Table D.3 (Continued)

THE REFERENCE MATRIX OF THERMAL AND MECHANICAL PROPERTIES FOR THE CORE (MCREF)

NO.	TREF DEGREES R	KCORE BTU/FT-SEC-R	KAIR BTU/FT-SEC-R	EMISSIVITY	G KSI	SZXU KSI
1	360.0	.100-03	.200-05	.70	.900+01	.10
2	460.0	.200-03	.360-05	.70	.800+01	.10
3	560.0	.250-03	.420-05	.70	.700+01	.10
4	700.0	.300-03	.500-05	.70	.700+01	.10
5	800.0	.200-03	.610-05	.70	.700+01	.08
6	1000.0	.150-03	.720-05	.70	.600+01	.06
7	1195.0	.100-03	.810-05	.70	.500+01	.05
8	1200.0	.100-03	.820-05	.70	.400+01	.05
9	1400.0	.600-04	.940-05	.70	.400+01	.03
10	1405.0	.500-04	.950-05	.70	.300+01	.03
11	1460.0	.100-04	.120-04	.70	.200+01	.02
12	2460.0	.100-04	.150-04	.70	.000	.00
13	3460.0	.100-04	.150-04	.70	.000	.00
14	3900.0	.100-04	.150-04	.70	.000	.00
15	7000.0	.100-04	.150-04	.70	.000	.00

Table D.3 (Continued)

THE REFERENCE MATRIX OF THERMAL AND MECHANICAL PROPERTIES FOR THE LOWER SANDWICH FACE (M4REF)

NO.	TREF DEGREES R	CP4 BTU/LR-R	E4 KSI	SU4 KSI	ALPHA4 1/R
1	360.0	.190-00	.330+04	20.0	.510-05
2	460.0	.200-00	.330+04	20.0	.510-05
3	560.0	.210-00	.320+04	15.0	.510-05
4	700.0	.240-00	.300+04	13.0	.500-05
5	800.0	.270-00	.290+04	15.0	.450-05
6	1000.0	.280-00	.280+04	14.0	.400-05
7	1195.0	.300-00	.220+04	18.0	.350-05
8	1200.0	.300-00	.220+04	18.0	.350-05
9	1400.0	.300-00	.500+03	11.0	.300-05
10	1405.0	.300-00	.500+03	11.0	.300-05
11	1460.0	.300-00	.100+03	4.0	.300-05
12	2460.0	.300-00	.000	.0	.300-05
13	3460.0	.300-00	.000	.0	.300-05
14	3900.0	.300-00	.000	.0	.300-05
15	7000.0	.300-00	.000	.0	.300-05

Table D.3 (Continued)

THE REFERENCE MATRIX OF THERMAL AND MECHANICAL PROPERTIES FOR THE INSULATOR (MIREF)

NO.	TREF DEG. R	KI BTU/FT-SEC-R	CPI BTU/LB-R
1	360.0	.450-05	.400-00
2	460.0	.750-05	.400-00
3	560.0	.830-05	.400-00
4	700.0	.103-04	.400-00
5	800.0	.117-04	.400-00
6	1000.0	.400-04	.400-00
7	1195.0	.400-04	.400-00
8	1200.0	.400-04	.400-00
9	1400.0	.450-04	.400-00
10	1405.0	.450-04	.400-00
11	1460.0	.460-04	.400-00
12	2460.0	.290-03	.400-00
13	3460.0	.700-03	.400-00
14	3900.0	.100-02	.400-00
15	7000.0	.100-02	.400-00

Table D.3 (Continued)

## THE REFERENCE MATRIX OF WALL ENTHALPY VALUES

NO.	TRFF DEG. R	HW BTU/LH
1	360.0	.69400+02
2	460.0	.10120+03
3	560.0	.13300+03
4	700.0	.16360+03
5	800.0	.19400+03
6	1000.0	.24210+03
7	1195.0	.29000+03
8	1200.0	.24300+03
9	1400.0	.34300+03
10	1405.0	.34600+03
11	1460.0	.36400+03
12	2460.0	.64500+03
13	3460.0	.95000+03
14	3900.0	.11400+04
15	7000.0	.18000+04

Table D.3 (Concluded)



```

A LIST
C      M      N      R1      R2      L      NDV      FIX      WGT      PCALC
      15      25      17      15      1      4      0      1      , 0
C      LAM      RHOI      RHOS      FTA1      ETA2      AA      RB
      1.875      6.0      172.8      0.6      0.6      4.47E4      4.0E4
C      SIGMA      EPS      DHC      CF      RHOAVP      RHOAC
      0.48E-12      0.8      2000.0      0.232      36.0      20.0
C      TSMAX      TRMAX      WMAX      TDMAX      GRN      WSUP      ORAT      PRAT      CC
      1200.0      660.0      0.02      1.0      1.0F31      1.0      1.0      1.0      100.0
C      LORFF
C      TMRFF      QRREF      VELREF      RHORFF      PREF      PDYNREF
      0.0      0.0      0.0      26500.0      1.164F-9      0.0      0.0
      50.0      2.5      0.0      26500.0      4.561E-9      0.0      20.0
      125.0      10.0      0.0      26500.0      2.379E-8      0.0      110.0
      187.0      20.0      5.0      26500.0      1.488E-7      0.0      100.0
250.0      40.0      7.5      26500.0      6.171F-7      0.0      95.0
      325.0      72.0      7.0      26500.0      1.630E-6      0.0      80.0
500.0      62.0      6.0      26000.0      1.630E-6      0.0      60.0
750.0      58.0      5.0      25500.0      1.630E-6      0.0      50.0
      875.0      56.0      4.8      25000.0      1.630E-6      0.0      50.0
      1000.0      61.0      4.5      24000.0      1.630E-6      0.0      50.0
      1250.0      78.0      3.0      22000.0      6.598E-6      0.0      45.0
      1375.0      80.0      2.5      20000.0      9.739E-6      0.0      40.0
      1500.0      70.0      2.4      18000.0      1.696E-5      0.0      40.0
      1750.0      48.0      1.0      14000.0      3.556E-5      0.0      40.0
      2000.0      23.0      0.0      10000.0      7.471F-5      0.0      40.0
      2250.0      5.0      0.0      5000.0      3.301F-4      0.0      30.0
      2400.0      0.0      0.0      0.0      7.647E-2      0.0      10.0
C      MARFF
C      TREF      KA      CPA      ETA      ECA      STUA      EPSTUA      SCUA      FPSCUA      ALPHA
360.0      1.8F-5      0.24      160.0      240.0      1.30      0.0087      5.08      0.025      20.0F-6
460.0      2.0E-5      0.30      140.0      160.0      1.20      0.0095      5.00      0.046      30.0E-6
560.0      2.1E-5      0.36      100.0      110.0      1.10      0.016      3.70      0.080      30.0E-6
700.0      2.1E-5      0.44      35.0      55.0      0.68      0.045      3.0      0.79      0.0
800.0      2.1E-5      0.50      12.0      45.0      0.32      0.060      2.7      0.20      0.0
1000.0      3.0E-5      0.60      3.0      12.0      0.13      0.050      0.5      0.2      -30.0F-6
1195.0      4.0E-5      0.70      0.0      6.0      0.05      0.07      0.06      0.20      -30.0E-6
1200.0      4.0E-5      0.70      0.0      6.0      0.05      0.07      0.06      1.0      -30.0E-6
1400.0      4.5E-5      0.80      0.0      0.0      0.01      0.01      1.0      0.0      -40.0F-6
1405.0      4.5E-5      0.80      0.0      0.0      0.01      0.01      1.0      0.0      -40.0F-6
1460.0      4.6E-5      0.80      0.0      0.0      0.01      0.01      1.0      0.0      -40.0E-6
2460.0      2.9E-4      0.80      0.0      0.0      0.01      0.01      1.0      0.0      -40.0E-6
3460.0      7.0E-4      0.80      0.0      0.0      0.01      0.01      1.0      0.0      -40.0E-6
3900.0      1.0E-3      0.80      0.0      0.0      0.01      0.01      1.0      0.0      -40.0E-6
7000.0      1.0E-3      0.80      0.0      0.0      0.01      0.01      1.0      0.0      -40.0E-6
C      MSKFF
C      TREF      CPS      ES      SUS      ALPHAS
360.0      0.175      11.4E3      45.0      12.0E-6
460.0      0.195      10.7E3      45.0      12.0E-6
560.0      0.215      10.2E3      45.0      12.0E-6
700.0      0.225      10.1E3      41.0      12.0E-6
800.0      0.230      9.8E3      38.0      12.0E-6
1000.0      0.240      7.9E3      18.0      13.0F-6

```

Table D.4 Actual Input Data (Corresponds to Table D.2)

```

1195.0 , 0.265 , 5.7E3 , 6.8 , 14.0E-6
1200.0 , 0.266 , 5.5E3 , 6.7 , 14.0E-6
1400.0 , 0.305 , 0.0 , 0.0 , 15.0E-6
1405.0 , 0.306 , 0.0 , 0.0 , 15.0E-6
1460.0 , 0.325 , 0.0 , 0.0 , 15.0E-6
2460.0 , 0.325 , 0.0 , 0.0 , 15.0E-6
3460.0 , 0.325 , 0.0 , 0.0 , 15.0E-6
3900.0 , 0.325 , 0.0 , 0.0 , 15.0E-6
7000.0 , 0.325 , 0.0 , 0.0 , 15.0E-6
C MIREF
C TREF KI CPT
360.0 , 0.45E-5 , 0.40
460.0 , 0.75E-5 , 0.40
560.0 , 0.83E-5 , 0.40
700.0 , 1.03E-5 , 0.40
800.0 , 1.17E-5 , 0.40
1000.0 , 0.40E-4 , 0.40
1195.0 , 0.40E-4 , 0.40
1200.0 , 0.40E-4 , 0.40
1400.0 , 0.45E-4 , 0.40
1405.0 , 0.45E-4 , 0.40
1460.0 , 0.46E-4 , 0.40
2460.0 , 0.24E-3 , 0.40
3460.0 , 0.70E-3 , 0.40
3900.0 , 0.10E-2 , 0.40
7000.0 , 0.10E-2 , 0.40
C HWKEF
69.4 , 101.2 , 133.0 , 168.6 , 194.0 , 242.1 , 290.0 , 293.0
343.0 , 346.0 , 364.0 , 645.0 , 950.0 , 1140.0 , 1800.0
C TINT
540.0,540.0,540.0,540.0,540.0,540.0,540.0,540.0,540.0,540.0,540.0,540.0
540.0,540.0,540.0,540.0,540.0,540.0,540.0,540.0,540.0,540.0,540.0
540.0,540.0
C TCURE TPLAS DTIM
810.0 , 900.0 , 10.0
C DX
0.01 , 0.10 , 0.10 , 0.05 , 0.0 , 0.0 , 0.0
C XMIN
0.1 , 0.001 , 0.01 , 0.5 , 0.0 , 0.0 , 0.0
C XMAX
0.4 , 0.02 , 0.2 , 3.0 , 0.0 , 0.0 , 0.0
C R T
1.0E-2 , 0.005
C X
0.25 , 0.0052 , 0.15 , 1.0
0.0 , 0.0 , 0.0
A FIN

```

Table D.4 (Concluded)

```

A LST
C M N R1 R2 L NDV FIX WGT PCALC
  15 , 26 , 25 , 15 , 1 , 5 , 0 , 0 , 1
C LAM RHO1 RHOS ETA1 ETA2 AA RB
  1.875 , 6.0 , 110.0 , 0.6 , 0.6 , 4.47E4 , 4.0E4
C SIGMA EPS DHC CF RHOAVP RHOAC
  0.48E-12 , 0.8 , 2000.0 , 0.232 , 36.0 , 20.0
C TSMAX TRMAX WMAX TDMAX GRN WSUP QRAT PRAT CC
  1200.0 , 660.0 , 0.02 , 1.0 , 1.0E31 , 1.0 , 1.0 , 1.0 , 100.0
C RHOC RHO4 CELDIA SR
  6.0 , 110.0 , 0.0208 , 0.10
C LDREF
C TMREF QCREF QRREF VELREF RHOREF PREF ALTITUDE
  0.0 , 0.0 , 0.0 , 37000.0 , 1.164E-9 , 6.305E-7 , 400000.0
  50.0 , 200.0 , 60.0 , 37000.0 , 1.246E-5 , 3.055E-4 , 262500.0
  100.0 , 500.0 , 310.0 , 35000.0 , 1.696E-5 , 5.846E-3 , 200000.0
  130.0 , 400.0 , 170.0 , 31000.0 , 2.047E-5 , 7.140E-3 , 195000.0
  170.0 , 240.0 , 30.0 , 25700.0 , 1.175E-5 , 3.879E-3 , 210000.0
  200.0 , 170.0 , 15.0 , 26500.0 , 8.036E-6 , 2.523E-3 , 220000.0
  250.0 , 100.0 , 5.0 , 25500.0 , 3.535E-6 , 9.955E-4 , 240000.0
  300.0 , 60.0 , 0.0 , 25000.0 , 1.246E-6 , 3.055E-4 , 262500.0
  350.0 , 40.0 , 0.0 , 25000.0 , 4.661E-7 , 1.143E-4 , 280000.0
  400.0 , 30.0 , 0.0 , 25000.0 , 2.660E-7 , 6.524E-5 , 290000.0
  450.0 , 25.0 , 0.0 , 25000.0 , 1.488E-7 , 3.737E-5 , 300000.0
  500.0 , 25.0 , 0.0 , 25000.0 , 1.488E-7 , 3.737E-5 , 300000.0
  550.0 , 30.0 , 0.0 , 24900.0 , 2.660E-7 , 6.524E-5 , 290000.0
  600.0 , 40.0 , 0.0 , 24800.0 , 4.051E-7 , 9.937E-5 , 282500.0
  650.0 , 60.0 , 0.0 , 24500.0 , 1.082E-6 , 2.655E-4 , 265000.0
  700.0 , 90.0 , 0.0 , 24000.0 , 3.535E-6 , 9.955E-4 , 240000.0
  725.0 , 115.0 , 0.0 , 23800.0 , 6.598E-6 , 2.018E-3 , 225000.0
  750.0 , 135.0 , 0.0 , 23000.0 , 1.175E-5 , 3.879E-3 , 210000.0
  775.0 , 162.0 , 0.0 , 22000.0 , 4.926E-5 , 1.810E-2 , 171000.0
  800.0 , 175.0 , 0.0 , 20000.0 , 6.668E-5 , 2.498E-2 , 162500.0
  820.0 , 120.0 , 0.0 , 16300.0 , 1.699E-4 , 5.947E-2 , 140000.0
  840.0 , 70.0 , 0.0 , 11500.0 , 4.151E-4 , 1.357E-1 , 120000.0
  860.0 , 35.0 , 0.0 , 6500.0 , 1.067E-3 , 3.290E-1 , 100000.0
  880.0 , 0.0 , 0.0 , 3300.0 , 3.008E-3 , 9.085E-1 , 78000.0
  900.0 , 0.0 , 0.0 , 1500.0 , 5.716E-3 , 1.682 , 65000.0
C MAREF
C TREF KA CPA ETA ECA STUA EPSTUA SCUA FPSCUA ALPHA
  360.0 , 1.8E-5 , 0.24 , 160.0 , 240.0 , 1.30 , 0.0087 , 5.08 , 0.025 , 20.0E-6
  460.0 , 2.0E-5 , 0.30 , 140.0 , 160.0 , 1.20 , 0.0095 , 5.00 , 0.046 , 30.0E-6
  560.0 , 2.1E-5 , 0.36 , 100.0 , 110.0 , 1.10 , 0.016 , 3.70 , 0.080 , 30.0E-6
  700.0 , 2.1E-5 , 0.44 , 35.0 , 55.0 , 0.68 , 0.045 , 3.0 , 0.79 , 0.0
  800.0 , 2.1E-5 , 0.50 , 12.0 , 45.0 , 0.32 , 0.060 , 2.7 , 0.20 , 0.0
  1000.0 , 3.0E-5 , 0.60 , 3.0 , 12.0 , 0.13 , 0.050 , 0.5 , 0.2 , -30.0E-6
  1195.0 , 4.0E-5 , 0.70 , 0.0 , 6.0 , 0.05 , 0.07 , 0.06 , 0.20 , -30.0E-6
  1200.0 , 4.0E-5 , 2.70 , 0.0 , 6.0 , 0.05 , 0.07 , 0.0 , 1.0 , -30.0E-6
  1400.0 , 4.5E-5 , 2.80 , 0.0 , 0.0 , 0.0 , 1.0 , 0.0 , 1.0 , -40.0E-6
  1405.0 , 4.5E-5 , 0.80 , 0.0 , 0.0 , 0.0 , 1.0 , 0.0 , 1.0 , -40.0E-6
  1460.0 , 4.6E-5 , 0.80 , 0.0 , 0.0 , 0.0 , 1.0 , 0.0 , 1.0 , -40.0E-6
  2460.0 , 2.9E-4 , 0.80 , 0.0 , 0.0 , 0.0 , 1.0 , 0.0 , 1.0 , -40.0E-6
  3460.0 , 7.0E-4 , 0.80 , 0.0 , 0.0 , 0.0 , 1.0 , 0.0 , 1.0 , -40.0E-6

```

Table D.5 Actual Input Data (Corresponds to Table D.3)

3900.0, 1.0E-3, 0.80, 0.0, 0.0, 0.0, 1.0, 0.0, 1.0, -40.0E-6  
 7000.0, 1.0E-3, 0.80, 0.0, 0.0, 0.0, 1.0, 0.0, 1.0, -40.0E-6

MSRFF					
C	TREFF	CPS	ES	SUS	ALPHAS
	360.0	0.19	3300.0	20.0	5.1E-6
	460.0	0.20	3300.0	20.0	5.1E-6
	560.0	0.21	3200.0	15.0	5.1E-6
	700.0	0.24	3000.0	13.0	5.0E-6
	800.0	0.27	2900.0	15.0	4.5E-6
	1000.0	0.28	2800.0	14.0	4.0E-6
	1195.0	0.30	2200.0	18.0	3.5E-6
	1200.0	0.30	2200.0	18.0	3.5E-6
	1400.0	0.30	500.0	11.0	3.0E-6
	1405.0	0.30	500.0	11.0	3.0E-6
	1460.0	0.30	100.0	4.0	3.0E-6
	2460.0	0.30	0.0	0.0	3.0E-6
	3460.0	0.30	0.0	0.0	3.0E-6
	3900.0	0.30	0.0	0.0	3.0E-6
	7000.0	0.30	0.0	0.0	3.0E-6
MCRFF					
C	TREFF	KCORE	KAIR	EMISS.	G SZXU
	360.0	1.0E-4	2.0E-6	0.7	9.0, 0.1
	460.0	2.0E-4	3.6E-6	0.7	8.0, 0.1
	560.0	2.5E-4	4.2E-6	0.7	7.0, 0.1
	700.0	3.0E-4	5.0E-6	0.7	7.0, 0.1
	800.0	2.0E-4	6.1E-6	0.7	7.0, 0.08
	1000.0	1.5E-4	7.2E-6	0.7	6.0, 0.06
	1195.0	1.0E-4	8.1E-6	0.7	5.0, 0.05
	1200.0	1.0E-4	8.2E-6	0.7	4.0, 0.05
	1400.0	0.6E-4	9.4E-6	0.7	4.0, 0.03
	1405.0	0.5E-4	9.5E-6	0.7	3.0, 0.03
	1460.0	0.1E-4	1.2E-5	0.7	2.0, 0.02
	2460.0	0.1E-4	1.5E-5	0.7	0.0, 0.0
	3460.0	0.1E-4	1.5E-5	0.7	0.0, 0.0
	3900.0	0.1E-4	1.5E-5	0.7	0.0, 0.0
	7000.0	0.1E-4	1.5E-5	0.7	0.0, 0.0
M4RFF					
C	TREFF	CP4	E4	SU4	ALPHA4
	360.0	0.19	3300.0	20.0	5.1E-6
	460.0	0.20	3300.0	20.0	5.1E-6
	560.0	0.21	3200.0	15.0	5.1E-6
	700.0	0.24	3000.0	13.0	5.0E-6
	800.0	0.27	2900.0	15.0	4.5E-6
	1000.0	0.28	2800.0	14.0	4.0E-6
	1195.0	0.30	2200.0	18.0	3.5E-6
	1200.0	0.30	2200.0	18.0	3.5E-6
	1400.0	0.30	500.0	11.0	3.0E-6
	1405.0	0.30	500.0	11.0	3.0E-6
	1460.0	0.30	100.0	4.0	3.0E-6
	2460.0	0.30	0.0	0.0	3.0E-6
	3460.0	0.30	0.0	0.0	3.0E-6
	3900.0	0.30	0.0	0.0	3.0E-6
	7000.0	0.30	0.0	0.0	3.0E-6
MIRFF					

Table D.5 (Continued)

```

C      TREF      KI      CPT
360.0 , 0.45E-5 , 0.40
460.0 , 0.75E-5 , 0.40
560.0 , 0.83E-5 , 0.40
700.0 , 1.03E-5 , 0.40
800.0 , 1.17E-5 , 0.40
1000.0 , 0.40E-4 , 0.40
1195.0 , 0.40E-4 , 0.40
1200.0 , 0.40E-4 , 0.40
1400.0 , 0.45E-4 , 0.40
1405.0 , 0.45E-4 , 0.40
1460.0 , 0.46E-4 , 0.40
2460.0 , 0.29E-3 , 0.40
3460.0 , 0.70E-3 , 0.40
3900.0 , 0.10E-2 , 0.40
7000.0 , 0.10E-2 , 0.40

C      HWKFF
69.4 , 101.2 , 133.0 , 168.6 , 194.0 , 242.1 , 290.0 , 293.0
343.0 , 346.0 , 364.0 , 645.0 , 950.0 , 1140.0 , 1800.0

C      TJNT
540.0,540.0,540.0,540.0,540.0,540.0,540.0,540.0,540.0,540.0,540.0,540.0,540.0
540.0,540.0,540.0,540.0,540.0,540.0,540.0,540.0,540.0,540.0,540.0,540.0
540.0,540.0,540.0

C      TCURE  TPLAS  DTIM
810.0 , 900.0 , 5.0

C      DX
0.01,0.01,0.01,0.01,0.02,0.01,0.0

C      XMIN
0.1 , 0.001 , 0.03125 , 0.001 , 0.01 , 0.5 , 0.0

C      XMAX
0.4 , 0.04 , 0.3 , 0.04 , 0.20 , 3.0 , 10.0

C      R      I
1.0E-8 , 0.001

C      X
0.16773245,0.01300506,0.03625361,0.01300506,0.026 , 0.56138
, 0.0

A FIN

```

Table D.5 (Concluded)

DATA FOR THE CURRENT DESIGN SPACE POINT  
 THE CURRENT VALUE OF R IS .10000-01  
 THE CURRENT VALUE OF T IS .50000-02

DESIGN POINT COORDINATES (FEET)

XMIN	X	XMAX
.10000	.24999999	.40000
.00100	.00520000	.02000
.01000	.14999999	.20000
.50000	1.00000000	3.00000

SYSTEM WEIGHT= .11799+02 LBS/50-FT  
 FIACCO MC-CORMICK FUNCTION VALUE= .33713+03

BEHAVIOR CONSTRAINT INFORMATION

NUMBER	TYPE OF BEHAVIOR, UNITS	CRITICAL VALUE	LIMITING VALUE	TIME AT CRIT. VALUE	NORMALIZED VALUE
1	TEMP. AT ARL.-STR. INTERFACE (R)	.77473+03	.12000+04	2400.00 SEC.	.35439-00
2	TEMP. AT BACK OF INSULATION (R)	.54517+03	.66000+03	2400.00 SEC.	.17398-00
3	DISPLACEMENT AT PANEL CENTER (FT)	-.12271-01	.20000-01	1470.10 SEC.	.38647-00
4	YIELD STRESS-STRUCTURE (KSI)	-.90249+01 -.19894+02	.45000+02	1.00 SEC.	.85851-00
5	YIELD STRESS-ARLATOR (KSI)	.69069-00 .68526-00	.11172+01 .39231+01	1318.05 SEC.	.82074-00
7	TENSILE STRAIN-ARLATOR	.45681-02	.14700-01	1.00 SEC.	.88925-00
8	COMPRESSIVE STRAIN-ARLATOR	-.11171-01	.20000-00	64.84 SEC.	.94414-00

TOTAL ARLATED DISTANCE IS .03963 FT.

TEMPERATURE DISTRIBUTION AT 2400.00 SECONDS

.1556+04	.1810+04	.1947+04	.2023+04	.2056+04	.2054+04	.2022+04	.1961+04	.1871+04	.1746+04
.1561+04	.1254+04	.1052+04	.8798+03	.7747+03	.7073+03	.6551+03	.6167+03	.5897+03	.5715+03
.5598+03	.5524+03	.5481+03	.5459+03	.5452+03					

Table D.6 Typical response output - thin substructure

DATA FOR THE CURRENT DESIGN SPACE POINT  
 THE CURRENT VALUE OF R IS .10000-07  
 THE CURRENT VALUE OF T IS .10000-02

DESIGN POINT COORDINATES (FEET)		
XMIN	X	XMAX
.10000	.16773245	.40000
.00100	.01300506	.04000
.03125	.03625361	.30000
.00100	.01300506	.04000
.01000	.02600000	.20000
.50000	.56138000	3.00000

SYSTEM THICKNESS= .25600-00 FT.

FIACCO MC-CORMICK FUNCTION VALUE= .25615-00

BEHAVIOR CONSTRAINT INFORMATION

NUMBER	TYPE OF BEHAVIOR UNITS	CRITICAL VALUE	LIMITING VALUE	TIME AT CRIT. VALUE	NORMALIZED VALUE
1	TEMP. AT ARL.-STR. INTERFACE (R)	.93752+03	.12000+04	900.00 SEC.	.21873-00
1	TEMP. AT BACK OF INSULATION (R)	.65225+03	.66000+03	900.00 SEC.	.11742-01
3	DISPLACEMENT AT PANEL CENTER (FT)	-.21306-02	.20000-01	56.50 SEC.	.89347-00
4	YIELD STRESS-ABLATOR (KSI)	.95429-00 .98414-00	.11181+01 .39351+01	347.49 SEC.	.24803-00
5	YIELD STRESS-UPPER SAND. FACE (KSI)	-.74434+01 -.59714+01	.16000+02	5.30 SEC.	.89556-00
6	INTERCELL FACE BUCKLING STRESS (KSI)	-.15390-00	.33204+04	884.62 SEC.	.99989-00
7	YIELD STRESS-LOWER SAND. FACE (KSI)	.38801+01 -.25725+01	.16000+02	5.30 SEC.	.87611-00
8	TENSILE STRAIN-ABLATOR	.61820-02	.14884-01	360.18 SEC.	.58466-00
9	COMPRESSIVE STRAIN-ABLATOR	-.11753-01	.20000-00	5.30 SEC.	.94124-00

TOTAL RELATED DISTANCE IS .05865 FT.

TEMPERATURE DISTRIBUTION AT 900.00 SECONDS.

.2185+04	.2418+04	.2558+04	.2636+04	.2669+04	.2665+04	.2629+04	.2563+04	.2465+04	.2334+04
.2170+04	.1967+04	.1698+04	.1269+04	.9375+03	.6936+03	.6858+03	.6788+03	.6726+03	.6673+03
.6627+03	.6589+03	.6560+03	.6539+03	.6527+03	.6523+03				

Table D.7 Typical response output (sandwich substructure)