

27. RESULTS FROM STUDIES OF HIGHWAY GROOVING AND TEXTURING BY SEVERAL STATE HIGHWAY DEPARTMENTS

By Larry G. Mosher
Clipper Manufacturing Company

SUMMARY

In an effort to combat the increasing rate of automobile accidents, several State highway departments have been evaluating the pavement grooving process to increase the safety of their highways. The process and results of pavement grooving being performed at several locations are discussed herein. At locations where accident data are available, this technique appears to be very effective in the prevention of wet-weather accidents; however, for most of the locations, accident data are not available.

INTRODUCTION

The commonly used "Slippery When Wet" sign is merely a temporary expedient for a correctable condition. The Special Traffic Safety Committee of the American Association of State Highway Officials has recommended skid-proofing slippery pavements to correct high-accident-rate locations (ref. 1). Several State highway departments have used pavement grooving for this purpose and it has proven very effective. Major reduction of accident rates immediately followed the grooving operations, as shown in this table:

Location	No. of accidents* and time period		Reduction (prorated), percent
	Before grooving	After grooving	
Georgia	66 (1 year)	46 (1 year)	30
Indiana	8 (1 year)	1 (4 months)	62
Minnesota	50 (1 year)	22 (9 months)	41
St. Louis Co.	8 (1 year)	4 (1 year)	50
Texas	120 (1 year)	(Significant reduction for 5 months; then accident rate increased)	

* For Georgia, number of accidents per 100 000 000 vehicle miles; for all locations, total number of accidents on both wet and dry pavement.

The reduction percentages have been calculated to represent the decrease in accidents for a full year of grooving-performance observation, even though information for

27

that length of time was not available for all the locations. The lack of effectiveness of the grooving in Texas was probably attributable to the very soft aggregate used in the concrete mixture. (See ref. 2.) Also, it should be noted that a closer groove pattern was used in Texas than was used in most projects.

It would not have been possible to prepare a paper of this scope without the cooperation of several people. Acknowledgment is hereby given to Christensen Diamond Services, Incorporated; Concut, Incorporated; and the several State highway departments that furnished much of the information.

DESCRIPTION OF PAVEMENT GROOVING PROCESS

Pavement grooving is the process of making several shallow cuts of a uniform depth, width, and shape in the surface of the pavement. For the studies contained in this report, nine different patterns of grooves have been used. (See fig. 1.) These patterns are produced by the use of cutting heads made of several diamond-impregnated saw blades (see fig. 2) or by the use of a diamond-impregnated cutting drum molded in the proper shape to cut the desired pattern. While there has been no definite indication of which pattern is the best suited, the one most commonly used on highway pavement grooving projects to date has been pattern "B" (see fig. 1) in the longitudinal direction. The speed of grooving is generally from 5 to 25 feet of forward progress per minute for a width of grooved pavement from 1 to 3 feet, depending on the type of material being cut and the grooving equipment being used.

Grooves placed in the longitudinal direction or parallel with the roadway have proven most effective in increasing directional control of the vehicle. The rubber tire on the automobile penetrates into the grooves forming a mechanical interlock that helps hold the vehicle in alignment with the roadway, much the same as tiny streetcar tracks. (See fig. 3 and ref. 3.) Longitudinal grooving is particularly effective in preventing hydroplaning accidents on curved sections of roadways, bridges, and tangent sections of roadways subject to high cross winds. During an emergency stop, the longitudinal grooves also help hold the vehicle within its own traffic lane, a factor which is extremely important on multiple-lane roadways. (See fig. 4 and ref. 2.)

Coefficient-of-friction measurements made with skid trailers may help identify dangerous pavements of the type described above, but do not necessarily indicate whether the grooves solve the problem. Pavements sometimes show a high value of coefficient of friction at speeds of 30 to 40 mph due to a good microtexture, but this effect may fall off rapidly with increased speed (ref. 4). Also, worn tires on vehicles may react differently than the tires used on the skid testing vehicle. If the skid trailer is equipped with its own watering device near the tire footprint, it may fail to indicate the improved drainage of the pavement that grooving normally provides. (See fig. 5.)

Most skid trailers today measure only braking coefficient of friction and do not indicate cornering traction. On high-speed roadways where stopping is generally not required, it would be advantageous to be able to measure side force. Tests at Wallops Island by NASA indicate that while longitudinal grooving may only increase the braking coefficient of friction a small amount, the cornering traction around a 500-foot-radius curve may be three to four times that for the ungrooved pavement. (See fig. 6.) The longitudinal grooves also provide low-pressure escape channels for the water, which will minimize or prevent dynamic hydroplaning. (See ref. 3 and fig. 7.)

Transverse grooving on highways has been used to a lesser extent than longitudinal grooving, partially because most grooving equipment available today lends itself more readily to placing grooves parallel to the roadway. Transverse grooving is most effective at high-accident-rate locations where vehicles make frequent stops such as intersections, crosswalks, and toll booths. The stopping distance for vehicles on slippery wet pavement at 30 mph has been reduced by 30 to 40 percent by the use of transverse grooves, as shown in the following table of results based on tests by the Louisiana Department of Highways at Baton Rouge:

Pavement	Pattern	Stopping distance, ft		Decrease, percent
		Before grooving	After grooving	
Concrete	"F"	76	52	31
Asphalt	"B"	74	45.5	40

If the pavement has a low coefficient-of-friction value prior to grooving, the value is generally increased significantly by placing transverse grooves. However, if the pavement shows a high coefficient-of-friction value prior to grooving, there is generally little, if any, increase after transverse grooving. Most of the studies reported herein indicate that the coefficient of friction on pavement with transverse grooves, although generally very high immediately following grooving operations, will tend to drop off as the pavement is subjected to traffic. This effect is apparently caused by a wearing down of the sharp edges of the grooves rather than any decrease in the groove size due to surface wear or deterioration. However, it must be remembered that conventional skid trailers may fail to indicate that transverse grooves provide improved drainage and escape channels for the water, particularly for worn or smooth tires.

Transverse grooves have been proven to reduce the hazards of hydroplaning by increasing the number of escape channels for water on both worn and good tires. (See fig. 7 and ref. 5.) They also greatly facilitate drainage by providing deeper channels for the water to run from the roadway, and as a result a much harder rainfall is required to cause hydroplaning problems. (See fig. 5.) The best pattern for transverse grooves has

not yet been determined. Tests at Wallops Island by NASA indicate that a 1 inch by 1/4 inch by 1/4 inch groove pattern gives the highest coefficient of friction of those patterns tested, but this pattern has not been tried on highways.

PROBLEMS ASSOCIATED WITH PAVEMENT GROOVING

There has been much concern about the effect that pavement grooving will have on the durability of the various pavement types in the various climates. The pavement grooving projects summarized in this report consist of various types and climatic conditions. One of the most frequent questions asked by highway engineers from the Northern States is "What will water freezing in the grooves do to the concrete pavement?" Laboratory tests have been made on 1/8-inch-wide grooves to a depth of $1\frac{3}{4}$ inches in concrete pavement, and even at this depth there was no deterioration resulting from a wedge action of ice within the grooves (ref. 6). An examination of grooved pavement in Minnesota, after it had been subjected to one winter of freeze-thaw cycles and studded tires, indicated no deterioration from the freeze-thaw cycles, but did show some wear in the wheel tracks, probably resulting from the use of studded tires. (See fig. 8.)

Much concern has been expressed about grooves in asphalt pavement losing their effectiveness by the flowing back together of this flexible material, particularly during hot weather. This result has been observed under certain conditions when a fairly new asphalt pavement or a pavement with a low aggregate content has been grooved. This condition seems predominant at locations subjected to power steering of the vehicle while it is stopped. Older asphalt pavement with high aggregate content seems to hold up very well. The pavement in St. Louis, Missouri, has been subjected to two summers and one winter of intersection traffic and looks almost as good as it did when the grooves were placed there 18 months ago. (See fig. 9.)

It appears that grooving may lose its effectiveness in 6 months when placed in concrete pavements containing extremely soft, fine and coarse aggregate. However, it must be remembered that in the one location where this loss in effectiveness was very obvious, pattern "D" was used; that pattern calls for a much closer spacing of the 1/8-inch-wide grooves than any other pattern. It is not known whether pattern "A" or "B" would hold up for a longer time in very soft material.

There have been some complaints that longitudinal grooving affects the steering of certain automobiles and motorcycles, but no severe problems have been encountered. However, when grooving pavement longitudinally, care should be taken to prevent any irregularities or "wiggles" in the pavement grooving pattern. Upon observing some early attempts of pavement grooving, it is noted that frequent variations in alinement can be found in the longitudinal grooves. (See fig. 10.) These variations may be attributed to

manual steering of the grooving equipment and the tendency for the equipment to slip downhill when working on a superelevation. Recent improvements in grooving equipment assure an alined grooving pattern parallel to the roadway. (See fig. 11.)

Another problem that has been noted, particularly during grooving operations, is the disposal of the water and the fine material cut from the grooves. Approximately 1 gallon of water per square foot of grooving is required to cool the cutting head. The resulting slurry can make the adjacent pavement very slippery, particularly if grooving begins on the high side of a multiple-lane roadway. (See fig. 12.) To avoid this situation and to facilitate cleaning up of the grooved area, a recent improvement in grooving equipment is a slurry pickup device. When a device of this type is used, the pavement is left free of dust or slipperiness and washed clean. (See fig. 13.)

SUMMARY OF PAVEMENT GROOVING PROJECTS IN SEVERAL STATES

The following results represent most of the work performed in the United States, with the exception of the State of California, on highway pavement grooving. The work in California has been reported in reference 7.

For simplification of reporting, the groove patterns have been referred to by letter and have been illustrated in figure 2. The dates given indicate when the work was performed.

Grooving in Concrete Pavement

Longitudinal grooving studies in concrete.- Longitudinal pavement grooving is seen to be very effective in eliminating wet-weather accidents where before and after records are available, even though the coefficient of friction is generally not significantly increased by this process. Longitudinal grooving in concrete pavement seems to hold up very well except in pavement where extremely soft, fine and coarse aggregate is used. A brief summary of projects at various locations follows:

COLORADO

LOCATION: I-25 southbound on Santa Fe Overpass in Denver

DATE: March 1968

PATTERN OF GROOVES: "B"

PURPOSE: To prevent hydroplaning accidents

DIMENSIONS: 12 feet wide; 325 feet long

COEFFICIENT OF FRICTION: Measurements were made with British Portable Tester.

	<u>Parallel to roadway</u>	<u>Transverse to roadway</u>
Before grooving:	60	60
After grooving:	60	85
8 months later:	60	80

ACCIDENT DATA: All accidents reported were on wet pavement.

	<u>Total no.</u>	<u>No. of injuries</u>
Before (4/1/67 to 10/1/67):	15	4
After (3/15/68 to 11/6/68):	0	0

COMMENTS: A 325-foot-long section of asphalt pavement was also grooved adjacent to this location. The accident data before grooving are for the total area (see data under studies on asphalt pavement).

GEORGIA

LOCATION: At a curve and tangent on I-20 between Decatur and Atlanta

DATE: May 1966

PATTERN OF GROOVES: "G" and another pattern similar to "G" but having grooves that are 3/16 inch wide at top with a 30° taper to a 1/8-inch width at bottom

PURPOSE: To prevent crossing-the-median accidents

DIMENSIONS: 12 feet wide; 9000 feet long (passing lane)

COEFFICIENT OF FRICTION: Measurements made with the Pennsylvania State University Drag Tester showed very little difference in skid resistance before and after grooving.

ACCIDENT DATA: All figures are based on 100 000 000 vehicle miles.

	<u>Total no.</u>	<u>Injury rate</u>	<u>Fatality rate</u>
Before (6 months):	66.0	70.8	14.1
After (6 months):	46.4	9.9	0

COMMENTS: Property damage was reduced 80 percent from the level before grooving. Grooves are holding up very well. Pavement consists of a good granite aggregate. The rectangular grooves of pattern "G" chip off at the edges to form shapes similar to the tapered grooves.

IDAHO

LOCATION: Twin bridges across the Snake River in Pocatello

DATE: August 1968

PATTERN OF GROOVES: "G"

PURPOSE: To prevent hydroplaning accidents

DIMENSIONS: Two wheel paths, each 3 feet wide and 800 feet long
(on each bridge)

COEFFICIENT OF FRICTION: The values 32 and 36 were obtained from measurements made with the Bureau of Public Roads skid trailer before grooving, no measurements were made after grooving.

ACCIDENT DATA:

January 1968 to August 1968: 12 total accidents
3 injuries
1 fatality

After-grooving data not yet available

COMMENTS: The grooves appear to help hold the vehicles in line with the roadway.

ILLINOIS

LOCATION: At intersection of State Route 48 on U.S. 66 south of Springfield

DATE: August 1966

PATTERN OF GROOVES: "I"

PURPOSE: To improve skid resistance

DIMENSIONS: 12 feet wide; 281 feet long (traffic lane)

COEFFICIENT OF FRICTION: Before grooving: 0.47
After grooving: .42

COMMENTS: Grooves are holding up very well. Accident data are not available. Grooving lowered the friction factor, but the method of testing was not given.

MINNESOTA - PROJECT #1

LOCATION: Curve on I-494 at Concord Street in South St. Paul

DATE: October 1967

PATTERN OF GROOVES: "B"

PURPOSE: To prevent wet-weather accidents

DIMENSIONS: 24 feet wide; approximately 1900 feet long; total area of 5000 square yards

ACCIDENT DATA:

	<u>Total no.</u>	<u>No. of injuries</u>	<u>No. of fatalities</u>
Before (1/1/67 to 12/31/67):	50	18	5
After (1/1/68 to 9/30/68):	22	5	0

COMMENTS: Grooves seem to be holding up well at this location. They seem to help hold the vehicles in line with the pavement.

MINNESOTA - PROJECT #2

LOCATION: Curve on I-94 in St. Paul

DATE: October 1967

PATTERN OF GROOVES: "B"

PURPOSE: As a precaution before opening to traffic

DIMENSIONS: 24 feet wide; total area of 3200 square yards

COMMENTS: This location is a tight curve where the speed limit reduces from 60 to 45 mph. Pavement grooving was done prior to opening the road to traffic in order to prevent spin-out of the vehicles during wet weather.

MINNESOTA - PROJECT #3

LOCATION: Curve on I-35W south of Minneapolis
DATE: October 1967
PATTERN OF GROOVES: "B"
PURPOSE: To prevent wet-weather accidents
DIMENSIONS: 24 feet wide; total area of 20 000 square yards
COEFFICIENT OF FRICTION: Portable skid tester indicated no improvements in coefficient of friction after grooving.
COMMENTS: There was a definite reduction in accident rate at this location after grooving; however, not enough data are available to attribute reduction completely to grooving. There is evidence of wear in the wheel paths, probably caused by the use of studded tires and an average daily traffic of approximately 50 000 vehicles.

MINNESOTA - PROJECT #4

LOCATION: Curve on I-90 near Austin
DATE: October 1968
PATTERN OF GROOVES: Similar to "I" with large grooves on 1-inch centers and only three small ridges between the grooves
PURPOSE: To prevent wet-weather accidents
DIMENSIONS: 24 feet wide; total area of 6488 square yards
COMMENTS: There were numerous wet-weather accidents at this location prior to grooving. It is too early to tell the results after grooving.

OHIO - PROJECT #1

LOCATION: At a curve and tangent on I-71 in Morrow County

DATE: Summer of 1966

PATTERN OF GROOVES: "B"

PURPOSE: To eliminate slippery pavement conditions in traffic lanes

DIMENSIONS: 9 feet wide; 2 miles long

COMMENTS: The grooving has substantially reduced the number of accidents, but exact data are not available. The grooving has not adversely affected pavement durability, but some wear is noticed in wheel path areas. Some automobile owners have complained about the poor handling of their vehicles over this section of pavement.

OHIO - PROJECT #2

LOCATION: Curve on I-270 exit ramp in Columbus

DATE: Summer of 1966

PATTERN OF GROOVES: "B"

PURPOSE: To eliminate slippery pavement conditions

DIMENSIONS: 12 feet wide; approximately 1500 feet long

COMMENTS: The grooving has proven very effective, but accident data are not available. There are no durability problems with the pavement, but some wear in the wheel paths is indicated.

OHIO - PROJECT #3

LOCATION: Ramp off I-75 at Lima
DATE: Summer of 1966
PATTERN OF GROOVES: "B"
PURPOSE: To eliminate slippery conditions on ramp
DIMENSIONS: 10 feet wide; 500 feet long
COMMENTS: The grooving has proven very effective, but accident data are not available. There are no durability problems with the pavement, but some wear in the wheel paths is indicated.

OHIO - PROJECT #4

LOCATION: Curve and tangent near Lima on I-75
DATE: May 1968
PATTERN OF GROOVES: "B"
PURPOSE: To eliminate slippery pavement conditions in traffic lane
DIMENSIONS: Two wheel paths, each 3 feet wide and 3 miles long
COMMENTS: It is too early to make any accurate judgment on effectiveness.

PENNSYLVANIA

LOCATION: Curve westbound on Hershey Road near Harrisburg

DATE: April 1967

PATTERN OF GROOVES: "B"

PURPOSE: To evaluate the feasibility of grooving pavement

DIMENSIONS: Two wheel paths, each 3 feet wide and 739 feet long

COEFFICIENT OF FRICTION: Skid numbers were obtained in accordance with ASTM E-274.

Before grooving: 27

After grooving: 30

12 months later: 28

COMMENTS: The Pennsylvania Department of Highways reports that 1/8-inch grooves were too shallow and are now practically nonexistent in some areas. No accident data were reported.

ST. LOUIS COUNTY ROAD DEPARTMENT

LOCATION: On ramp to Ashby Road at Midland Boulevard in St. Louis, Missouri

DATE: April 1967

PATTERN OF GROOVES: "C"

PURPOSE: To realine vehicle after turning on to a ramp

DIMENSIONS: 10 feet wide; 60 feet long

COMMENTS: This was a very polished concrete pavement. The grooves are holding up okay after 18 months. (For accident data at this intersection, see studies on asphalt pavement with transverse grooving.)

TEXAS

LOCATION: Curve and tangent on I-35 in San Antonio
DATE: August 1962
PATTERN OF GROOVES: "D"
PURPOSE: To prevent wet-weather accidents
DIMENSIONS: 48 feet wide; 1.2 miles long
COEFFICIENT OF FRICTION: Tests were made on wet pavement at 30 mph.

	<u>Stopping distance</u>	<u>Coefficient of friction</u>
Before grooving (measured by stopping car):	94 feet	0.32
After grooving (measured by stopping car):	72 feet	.42
6 months later (measured by skid trailer):	-----	.28

ACCIDENT DATA:

Before (1/1/61 to 1/1/62): 120 total (60 wet weather)
After: Significant reduction for 5 months; then accident rate increased

COMMENTS:

The loss in effectiveness was probably attributable to the very soft, fine and coarse aggregate. Sections of the grooved area were overlaid with type "D" asphaltic concrete in August 1963. In April 1964 the remaining grooved area was overlaid.

UTAH

LOCATION: On foothill overpass at I-80 in Salt Lake City
DATE: January 1967
PATTERN OF GROOVES: "G"
PURPOSE: To improve drainage of bridge deck
DIMENSIONS: 12 feet wide; 99 feet long
COEFFICIENT OF FRICTION: Measurements were made with Bureau of Public Roads skid trailer.

Before grooving (taken on adjacent deck):	0.30
7 months later:	.39

COMMENTS:

Accident data are not available. The Utah State Department of Highways reports that drainage is improved but grooves are wearing off.

WYOMING -- PROJECT #1

LOCATION: Entrances to tunnels at Green River
DATE: April 1968
PATTERN OF GROOVES: "B"
PURPOSE: To prevent wet- and icy-pavement accidents
DIMENSIONS:
 Westbound entrance: 24 feet wide; 300 feet long
 Eastbound entrance: 24 feet wide; 400 feet long
ACCIDENT DATA:
 Before (Nov. 1966 to May 1968): 3 icy; 1 wet
 After (May 1968 to Nov. 1968): 0 icy; 0 wet
COMMENTS: There have been no icy conditions since grooving, but the Wyoming Highway Department believes that this grooving should be an answer to the problem of tracking moisture into the tunnels, which causes the so-called "Black Ice" condition. The pavement is holding up very good.

WYOMING -- PROJECT #2

LOCATION: Archer overhead bridge 3 miles east of Cheyenne
DATE: June 1967
PATTERN OF GROOVES: "C"
PURPOSE: To reduce accidents caused by rain and frost on bridge deck
DIMENSIONS: 28 feet wide; 380 feet long
ACCIDENT DATA: Most accidents occurred on frost or wet pavement.
 Before (5 years to June 1967): 20 total
 After (June 1967 to Nov. 1968): 0 total
COMMENTS: Grooves are holding up very well.

WYOMING – PROJECT #3

LOCATION: I-25 on Central Avenue interchange bridge in Cheyenne

DATE: June 1967

PATTERN OF GROOVES: "C"

PURPOSE: To reduce minor fender-bender accidents during wet weather

DIMENSIONS: 28 feet wide; 300 feet long

COMMENTS: No specific accident data are available, but the frequency of minor accidents has been reduced sharply. The grooved pavement is holding up very good. The approaches to the structure will be grooved in the near future.

Transverse grooving studies in concrete. - Transverse grooves in concrete high-ways have been used primarily at intersections. They decrease the stopping distance on slippery pavement by improving drainage and by increasing the coefficient of friction. There is generally a decrease in coefficient of friction of the grooved pavement after a few months of traffic; however, the drainage improvement appears long lasting. A brief summary of several projects follows:

FLORIDA (ST. AUGUSTINE) - PROJECT #1

LOCATION: Intersection of King Street on State Route 5 in St. Augustine

DATE: August 1967

PATTERN OF GROOVES: "E"

PURPOSE: To reduce stopping distance on wet pavement

DIMENSIONS:

- 48 feet (four lanes) wide; 7-percent textured area 600 feet long
- 50-percent textured area 300 feet long
- 100-percent textured area 200 feet long

COEFFICIENT OF FRICTION: Measurements were made with Florida skid trailer with ASTM Test Tires at 40 mph.

	<u>December 5, 1967</u>		<u>August 6, 1968</u>	
	<u>Traffic lane</u>	<u>Passing lane</u>	<u>Traffic lane</u>	<u>Passing lane</u>
Control:	42	45	43	46
7-percent textured:	40	45	43	50
50-percent textured:	46	44	45	50
100-percent textured:	43	51	50	52

COMMENTS: The 7-percent textured area consists of a 3-foot textured area every 40 feet. The 50-percent textured area consists of a 3-foot textured area alternating with a 3-foot untreated area. No accident data are available. This pattern was not effective in increasing tire noise as a warning. (See fig. 14.)

FLORIDA (ST. AUGUSTINE) – PROJECT #2

LOCATION: On southbound lanes of State Route 5 in St. Augustine
DATE: August 1967
PATTERN OF GROOVES: "E"
PURPOSE: To reduce stopping distance on wet pavement
DIMENSIONS: Two lanes wide; 650 feet long
COEFFICIENT OF FRICTION: Measurements were made with Florida skid trailer.

	<u>December 5, 1967</u>		<u>August 6, 1968</u>	
	<u>Traffic lane</u>	<u>Passing lane</u>	<u>Traffic lane</u>	<u>Passing lane</u>
Control:	40	41	42	48
Textured:	43	43	52	54

COMMENTS: No accident information is available. The increase in coefficient of friction between December 1967 and August 1968 was not explained.

FLORIDA (ST. AUGUSTINE) – PROJECT #3

LOCATION: Approach to sharp curve on State Route 5 in St. Augustine
DATE: August 1967
PATTERN OF GROOVES: "T"
PURPOSE: To evaluate grooving
DIMENSIONS: Two lanes wide; 450 feet long
COEFFICIENT OF FRICTION: Measurements were made with Florida skid trailer.

	<u>December 5, 1967</u>		<u>August 6, 1968</u>	
	<u>Traffic lane</u>	<u>Passing lane</u>	<u>Traffic lane</u>	<u>Passing lane</u>
Control:	40	41	42	48
50-percent textured:	42	41	44	49

COMMENTS: The 50-percent textured area consists of a 3-foot grooved area alternating with a 3-foot ungrooved area. No accident data are available.

FLORIDA (MIAMI) - PROJECT #4

LOCATION: Approach to intersection on State Route 5 in Miami
DATE: August 1967
PATTERN OF GROOVES: "E"
PURPOSE: To reduce stopping distance on wet pavement
DIMENSIONS: Two lanes wide; 300 feet long
COEFFICIENT OF FRICTION: Measurements were made with Florida skid trailer.

	<u>January 10, 1968</u>		<u>August 14, 1968</u>	
	<u>Traffic lane</u>	<u>Passing lane</u>	<u>Traffic lane</u>	<u>Passing lane</u>
Control:	43	49	45	48
Textured:	47	50	44	50

COMMENTS: No accident data are available.

ILLINOIS

LOCATION: At intersection of State Route 48 on U.S. 66 south of Springfield
DATE: August 1966
PATTERN OF GROOVES: "I"
PURPOSE: To improve skid resistance at high-accident-rate location
DIMENSIONS: 12 feet wide; 240 feet long (passing lane)
COEFFICIENT OF FRICTION: Test method is not given.
Before grooving (in adjacent lane): 0.47
After grooving: .48
COMMENTS: Grooves are holding up very well. Accident data are not available.

LOUISIANA

LOCATION: Intersection in Baton Rouge
DATE: October 1966
PATTERN OF GROOVES: "F" and "G"
PURPOSE: To decrease stopping distance
COEFFICIENT OF FRICTION: Measurements were made by stopping a car at 30 mph.
on wet pavement.
Before grooving: 76 feet
After grooving: 52 feet
COMMENTS: Accident data are not available.

TEXAS

LOCATION: I-35 in downtown San Antonio
DATE: July 1966
PATTERN OF GROOVES: "F"
PURPOSE: To test effect of grooving on skid resistance
DIMENSIONS: 48 feet wide; 100 feet long
COEFFICIENT OF FRICTION: Measurements were made with skid trailer at 40 mph.
Before grooving: 0.25
After grooving: .58
45 days later: .38
10 months later: .30
COMMENTS: Accident data are not available. The Texas Highway Department believes the soft aggregate used in the pavement caused the loss of skid resistance after grooving.

UTAH

LOCATION: On foothill overpass at I-80 in Salt Lake City

DATE: January 1967

PATTERN OF GROOVES: "F" and "T"

PURPOSE: To improve drainage

DIMENSIONS: 12 feet wide; 181 feet long

COEFFICIENT OF FRICTION: Measurements were made with Bureau of Public Roads
skid trailer.

Before grooving (adjacent structures):	0.33 and 0.29
After grooving (pattern "F"):	.38
After grooving (pattern "T"):	.41

COMMENTS: No accident data are reported. Drainage of water is improved, but grooves are wearing off.

Grooving In Asphalt Pavement

Longitudinal grooving studies in asphalt. - The initial effectiveness of grooving asphalt pavement longitudinally is the same as for concrete pavement, but the durability is questionable if the pavement is highly flexible or has a low aggregate content. If the pavement is dense and has a high aggregate content, longitudinal grooves hold up well in asphalt pavement. A brief summary of a few projects follows:

COLORADO

LOCATION: I-25 on Santa Fe Overpass in Denver

DATE: March 1968

PATTERN OF GROOVES: "B"

PURPOSE: To prevent hydroplaning accidents

DIMENSIONS: 12 feet wide; 325 feet long

COEFFICIENT OF FRICTION: Measurements were made with British Portable Tester.

	<u>Parallel to roadway</u>	<u>Transverse to roadway</u>
Before grooving:	70	70
After grooving:	70	82
8 months later:	68	68

ACCIDENT DATA: All accidents reported were on wet pavement.

	<u>Total no.</u>	<u>No. of injuries</u>
Before (4/1/67 to 10/1/67):	15	4
After (3/15/68 to 11/6/68):	4	0

COMMENTS: A 325-foot-long section of concrete pavement was also grooved adjacent to this location. The accident data before grooving are for the total area (see data under studies on concrete pavement). The accidents occurred in late summer; the grooves were kneaded over by then. This was a thin asphalt overlay over an existing concrete pavement.

IDAHO

LOCATION: Pocatello

DATE: August 1968

PATTERN OF GROOVES: 'T'

PURPOSE: To eliminate slipperiness caused by bleeding asphalt

DIMENSIONS: 9 feet wide; $1\frac{1}{4}$ miles long

COEFFICIENT OF FRICTION: Measurements were made with Bureau of Public Roads
skid trailer
Before grooving: 36
After grooving: Not measured

COMMENTS: One fatality was reported for June 1968, but no other
accident data were reported. Grooving appears to be
standing up well, but more will be known after hot
weather next summer.

PENNSYLVANIA

LOCATION: Tangent on Hershey Road near Harrisburg

DATE: April 1967

PATTERN OF GROOVES: "B"

PURPOSE: To evaluate the feasibility of grooving pavement

DIMENSIONS: Two wheel paths, each 3 feet wide and 285 feet long

COEFFICIENT OF FRICTION: Skid numbers were obtained in accordance with
ASTM E-274.
Before grooving: Skid number 31
After grooving: Skid number 42
12 months later: Skid number 39

COMMENTS: The Pennsylvania Department of Highways reports that
1/8-inch grooves were too shallow and are practically
nonexistent in some areas. No accident data were
reported.

WYOMING

LOCATION: On a slight curve 1 mile east of Cheyenne

DATE: June 1967

PATTERN OF GROOVES: "A"

PURPOSE: To evaluate grooving asphalt pavement

DIMENSIONS: 4 feet wide; 100 feet long

COMMENTS: Pavement was constructed in 1958. The grooving is holding up very well after about 18 months of service.

Transverse grooving studies in asphalt.- Significant increases in coefficient of friction have been realized by transversely grooving slippery asphalt pavement. If the pavement is dense and has a high aggregate content, the grooves hold up well. Rear-end-collision skidding accidents have been substantially reduced by grooving asphalt pavement transversely at intersections. While some projects report a decrease in coefficient of friction after several months, the drainage is still improved. A brief summary of several projects follows:

FLORIDA (MIAMI) – PROJECT #1

LOCATION: Approach to intersection on State Route 5 near Miami
 DATE: July 1967
 PATTERN OF GROOVES: "E"
 PURPOSE: To improve skid resistance
 DIMENSIONS: Two lanes wide; 300 feet long
 COEFFICIENT OF FRICTION: Measurements were made with Florida skid trailer.

	<u>January 10, 1968</u>		<u>August 14, 1968</u>	
	<u>Traffic lane</u>	<u>Passing lane</u>	<u>Traffic lane</u>	<u>Passing lane</u>
Control:	32	37	28	34
Textured:	40	46	35	37

COMMENTS: Accident data are not available.

FLORIDA (MIAMI) – PROJECT #2

LOCATION: Intersection on N.W. 27th Avenue at 119th Street in Miami
 DATE: June 1967
 PATTERN OF GROOVES: "E"
 PURPOSE: To improve skid resistance
 DIMENSIONS: Two lanes wide; 300 feet long
 COEFFICIENT OF FRICTION: Measurements were made with Florida skid trailer.

	<u>January 10, 1968</u>		<u>August 14, 1968</u>	
	<u>Traffic lane</u>	<u>Passing lane</u>	<u>Traffic lane</u>	<u>Passing lane</u>
Control:	30	30	31	31
Textured:	48	45	37	37

COMMENTS: Accident data are not available.

FLORIDA (MIAMI) - PROJECT #3

LOCATION: Intersection on Biscayne Boulevard at N.E. 96th Street
in Miami

DATE: June 1967

PATTERN OF GROOVES: "E"

PURPOSE: To improve skid resistance

DIMENSIONS: Two lanes wide; 1300 feet long

COEFFICIENT OF FRICTION: Measurements were made with Florida skid trailer.

	<u>January 10, 1968</u>		<u>August 14, 1968</u>	
	<u>Traffic lane</u>	<u>Passing lane</u>	<u>Traffic lane</u>	<u>Passing lane</u>
Northbound roadway				
Control:	30	33	28	34
Textured:	46	43	38	40
Southbound roadway				
Control:	30	32	28	34
Textured:	42	45	38	40

COMMENTS: Accident data are not available.

ILLINOIS

LOCATION: Intersection approach on U.S. 66, 30 miles south of
Springfield

DATE: August 1966

PATTERN OF GROOVES: "I"

PURPOSE: To improve skid resistance

DIMENSIONS: Two lanes wide; 200 feet long

COEFFICIENT OF FRICTION:

	<u>Traffic lane</u>	<u>Passing lane</u>
Before grooving:	0.31	----
After grooving:	.34	0.35

COMMENTS: Accident data are not available. In less than 1 year the
the grooves were closed.

INDIANA

LOCATION: State Route 100 approaching intersection with State Route 67 in Indianapolis

DATE: April 1968

PATTERN OF GROOVES: "B"

PURPOSE: To reduce skidding accidents

DIMENSIONS: Three lanes wide; 310 feet long

ACCIDENT DATA:

 Before (4/24/67 to 4/24/68): 8 total (3 on wet pavement)

 After (4/24/68 to 8/23/68): 1 total (0 on wet pavement)

COMMENTS: Some closing of the grooves is reported.

LOUISIANA

LOCATION: At traffic light on Flores Road in Baton Rouge

DATE: September 1967

PATTERN OF GROOVES: "B"

PURPOSE: To prevent skidding accidents

DIMENSIONS: One lane wide; 120 feet long

COEFFICIENT OF FRICTION: Tests were made on wet pavement at 30 mph.

	<u>Stopping distance</u>	<u>Skid number</u>
Before grooving (measured by stopping car):	74 feet	--
After grooving (measured by stopping car):	45.5 feet	--
12 months later (measured by ASTM skid trailer):	-----	40

COMMENTS: No accident data are reported. Grooves are holding up very well after 1 year. Skid resistance dropped; however, a different test method was used.

ST. LOUIS COUNTY ROAD DEPARTMENT

LOCATION: On Midland Boulevard at Ashby Road in St. Louis,
Missouri

DATE: April 1967

PATTERN OF GROOVES: "C"

PURPOSE: To reduce skidding accidents

DIMENSIONS: Two 10-foot-wide lanes; 90 feet long

ACCIDENT DATA:
Year of 1966: 8 rear end
Year of 1967: 3 rear end; 1 left turn

COMMENTS: Shortly after grooving, the County Road Department
removed a stop sign at this location. Normally this
would have increased major rear-end accidents, but
actually they decreased 62.5 percent. Minor accidents
are not reported or filed.

Grooving Projects Underway or Recently Completed

Louisiana. - In August 1968 pattern "F" transverse grooves were placed at an intersection in Baton Rouge. For additional information, contact Verdi Adam of the Louisiana Department of Highways in Baton Rouge.

Minnesota. - During 1968 longitudinal grooves were placed at five locations on rural routes in Minnesota. These projects totaled 17 133 square yards of grooved pavement. The sections were 24 feet wide and varied in length from 1333 to 6400 feet. All except one location had a history of wet-weather accidents. One project was grooved before the pavement was open to traffic in an effort to prevent accidents. For additional information, contact C. K. Preus of the Minnesota Department of Highways in St. Paul.

Nebraska. - Pattern "B" grooves are currently being placed in concrete pavement on I-80 westbound near 42nd Street in Omaha. Three lanes are being longitudinally grooved for a distance of approximately 1 mile. For additional information, contact Robert Meyer, Traffic Engineer, Department of Roads, Lincoln, Nebraska.

New York. - In June 1968 longitudinal grooves were placed on Major Deegan Boulevard and Long Island Expressway in New York City. The groove pattern was the same as pattern "I" except that large grooves were 1/4 inch deep. The purpose of grooving was to improve directional control and decrease occurrences of hydroplaning. For additional information, contact Bob Murphy, City of New York, or R. Winton, Parks Department.

In June 1968 longitudinal pattern "B" grooves were placed on the Southern State Parkway at various entrance and exit ramps. The purpose of grooving was to increase traction on ramps to reduce skidding. For more information, contact the Jones Beach State Parkway Authority.

Wisconsin. - In October 1968 longitudinal pattern "B" grooves were placed on a 1200-foot curve on the North-South Freeway at Howard Avenue in Milwaukee. The grooving was done to prevent cars from skidding into the guardrail during wet weather. For more information, contact James E. Meier, District Engineer of Wisconsin State Highway Department at Milwaukee.

RECOMMENDATIONS

According to present indications, test equipment other than skid trailers must be used in order to give a proper evaluation of the effectiveness of pavement grooving. Stopping and cornering tests with a vehicle under artificially wet conditions would probably provide the most accurate information, but these tests are very impractical for use on highways under traffic. There is a need for a friction measuring device that would not

only indicate braking coefficient of friction but would also indicate hydroplaning conditions, vehicle cornering ability, pavement drainage, and the reaction to all these factors when contact is made with the pavement by worn or smooth tires.

If a test method could be devised that would indicate all or most factors related to vehicle performance before and after grooving, then it would be easier to determine which pattern of grooves is proper under the various conditions. This test method would indicate what pattern of grooves should be used under various conditions and to what limits the pavement grooving should extend.

Until a complete test procedure is available, accidents should be tabulated and analyzed prior to selecting a location for grooving. These analyzed results should be compared with results for a comparable period of time and traffic after grooving. While this paper indicates that grooves have failed to improve the coefficient of friction under certain conditions, there has been no report that grooving has failed to decrease the number of wet-weather accidents for a period of at least 5 months and in many cases much longer after grooving. Processes used for tabulating and analyzing accidents in most states are currently being updated.

While in most cases the initial effectiveness of pavement grooving is rather consistent, the life of this effectiveness is varied. Thus care must be taken in selecting pavement grooving as a corrective measure to wet-weather accidents. If new, very flexible asphalt pavement with a low aggregate content makes up the existing surface, the grooves are likely to close up after a period of time. If a very soft, fine and coarse aggregate is used in concrete pavement, the top surface may wear away causing a loss of effectiveness of the grooves. To date there has been no report of regrooving pavement after it appears to lose its effectiveness. More study is required to determine which pattern should be used in marginal pavements. Also, it should be determined if the pavement is actually becoming unsafe just because its coefficient of friction decreases from the value realized immediately following the grooving operations.

To date there has been no report of pavement deterioration as a result of grooving. In the one location where an overlay was placed on the grooved area, the grooves provided a good surface for bonding the overlay.

SAFETY FEATURES

Longitudinal grooves will prevent many accidents during wet weather and some accidents during dry weather by providing the pavement with the following safety features:

- (1) Directional stability for cornering through mechanical interlock of the rubber tire within the grooves

- (2) Low-pressure escape routes for the water beneath the tire to prevent hydroplaning
- (3) Directional control and resistance to cross wind through mechanical interlock of the rubber tire within the grooves
- (4) Directional stability during locked-wheel skidding through mechanical interlock of the rubber tire within the grooves
- (5) Frost or thin-ice interruptions that facilitate the dispersion of these materials from the tire track.

A typical section of pavement improved by longitudinal grooving is illustrated in figure 15. Curves, bridges, ramps, and open road subjected to frequent cross winds all benefit from longitudinal grooving.

Transverse grooves in pavement will reduce skidding accidents during wet weather by providing the pavement with the following safety features:

- (1) A desirable coefficient of friction
- (2) Reduction of 30 to 40 percent in the stopping distance of vehicles during wet weather at 30 mph on slippery pavements
- (3) Facilitation of drainage to allow faster drying of the pavement
- (4) Removal of oil, molten rubber, and so forth from the tire footprint to restore normal tire-pavement contact during a locked-wheel skid
- (5) Frost or thin-ice interruptions that facilitate the dispersion of these materials from the tire track.

Transverse grooves are usually most beneficial for reducing stopping distance at intersections, crosswalks, and toll booths. Some projects have used interrupted patterns, as illustrated in figure 14.

Sometimes both longitudinal and transverse grooves are used at the same location. (See fig. 16.) Transverse grooves are used to help vehicles stop, while longitudinal grooves are used to assist the vehicle in directional control.

Pavement grooving in either direction (longitudinal or transverse) reduces the hazards of hydroplaning. The grooves provide low-pressure escape routes for the water from the tire footprint area. A much greater water depth is required for hydroplaning to occur on grooved pavement than on smooth or fine textured pavement. A combination of speed and water depth sufficient to cause dynamic hydroplaning on properly grooved pavement is unlikely to occur on modern highways with present-day automobiles.

CONCLUDING REMARKS

In an effort to combat the increasing rate of automobile accidents, several State highway departments have been evaluating the pavement grooving process. At locations where accident data are available, this technique appears to be very effective in the prevention of wet-weather accidents. Curves, bridges, ramps, and open road subjected to frequent cross winds all benefit from longitudinal grooving. Transverse grooves are usually most beneficial for reducing stopping distance at intersections, crosswalks, and toll booths.

REFERENCES

1. Anon.: Highway Design and Operational Practices Related to Highway Safety. Amer. Ass. State Highway Officials, Feb. 1967, p. 62.
2. Nixon, John F.: Report on Concrete Pavement Grooving in Texas. Dep. Res. Rep. No. SS 8.0, Texas Highway Dep., Aug. 1968, pp. 10-11.
3. Horne, Walter B.: Skidding Accidents on Runways and Highways Can Be Reduced. Astronaut. Aeronaut., vol. 5, no. 8, Aug. 1967, pp. 48-55.
4. Sabey, Barbara E.: Road Surface Texture and the Change in Skidding Resistance With Speed. RRL Rep. No. 20, Brit. Min. Transp., 1966, p. 7.
5. Anon.: Hazards of Tire Hydroplaning – A Sequel. NASA Langley Research Center Film Serial No. L-957, 1968.
6. Perenchio, William: Effect of Surface Grinding and Joint Sawing on the Durability of Paving Concrete. J. PCA Res. Develop. Lab., vol. 6, no. 1, Jan. 1964, pp. 16-19.
7. Farnsworth, Eugene E.: Pavement Grooving on Highways. Pavement Grooving and Traction Studies, NASA SP-5073, 1969. (Paper No. 25 herein.)

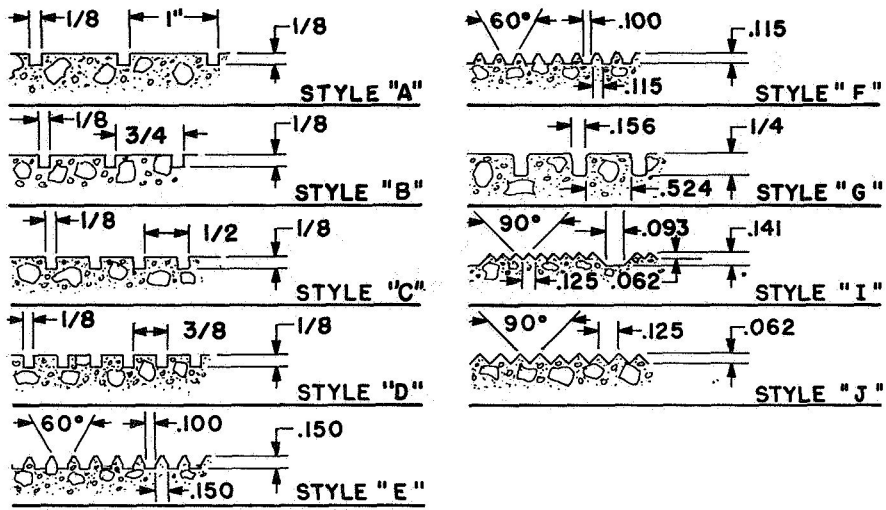

Figure 1.- Groove patterns.

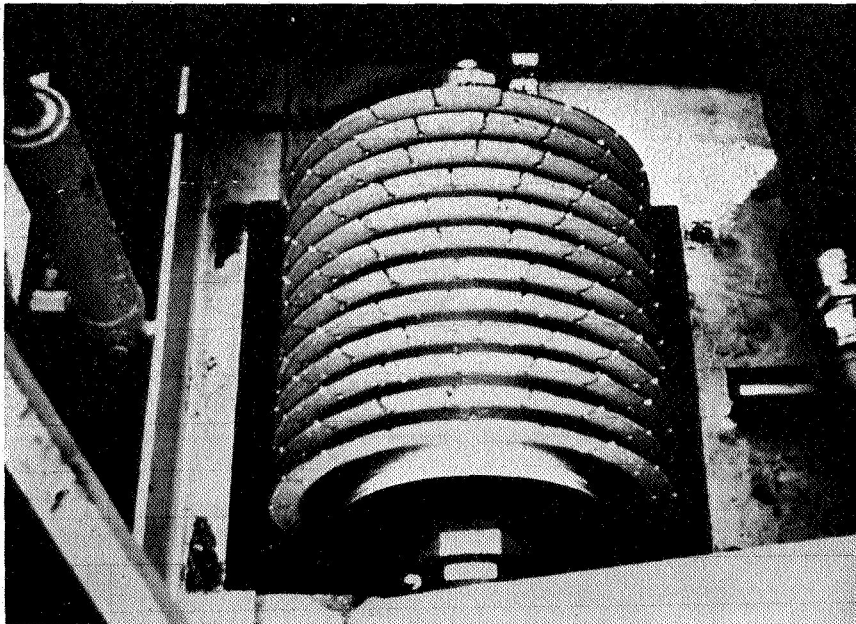

Figure 2.- Cutting head.

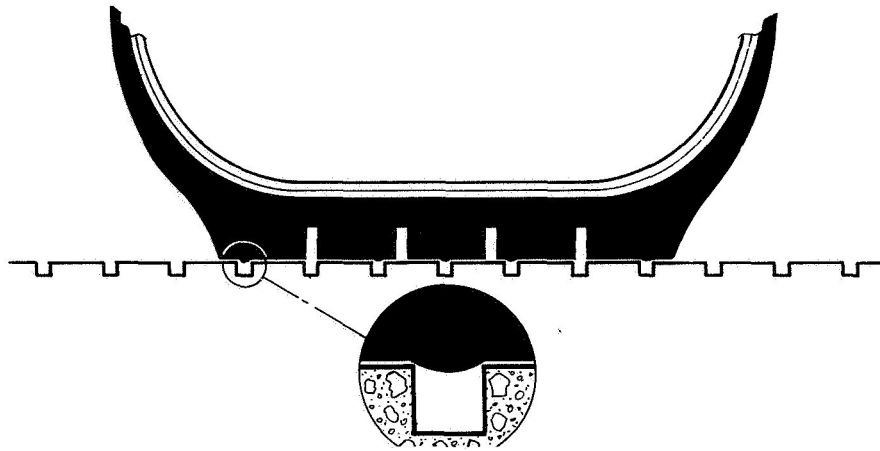

Figure 3.- Profile of a tire on longitudinal groove pattern.

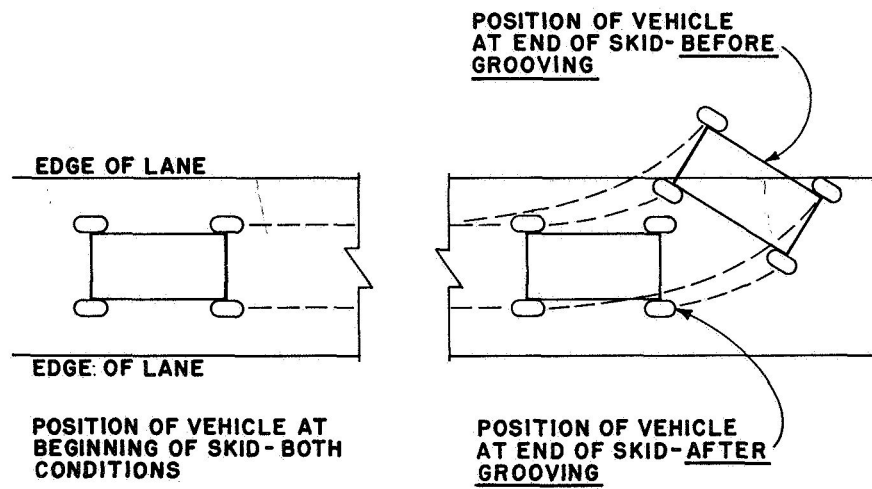

Figure 4.- Skid pattern before and after grooving.

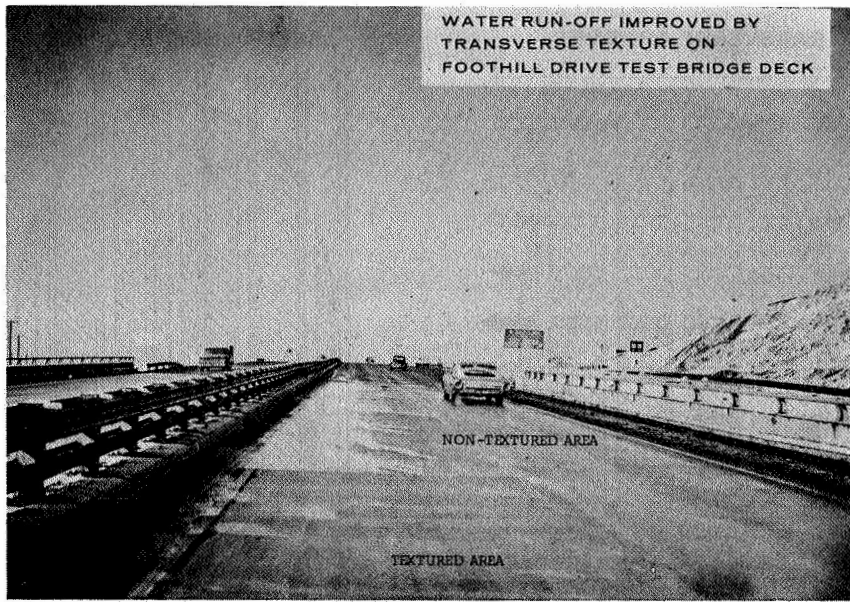

Figure 5.- Pavement drainage.

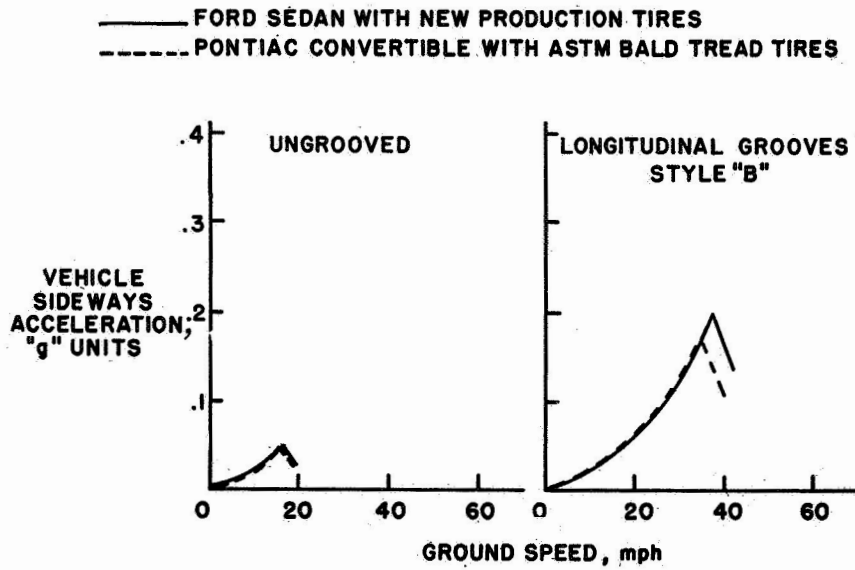

Figure 6.- Vehicle spin-out on 500-foot-radius road curve. Smooth Jennite surface; mixture of water and hydrolube.

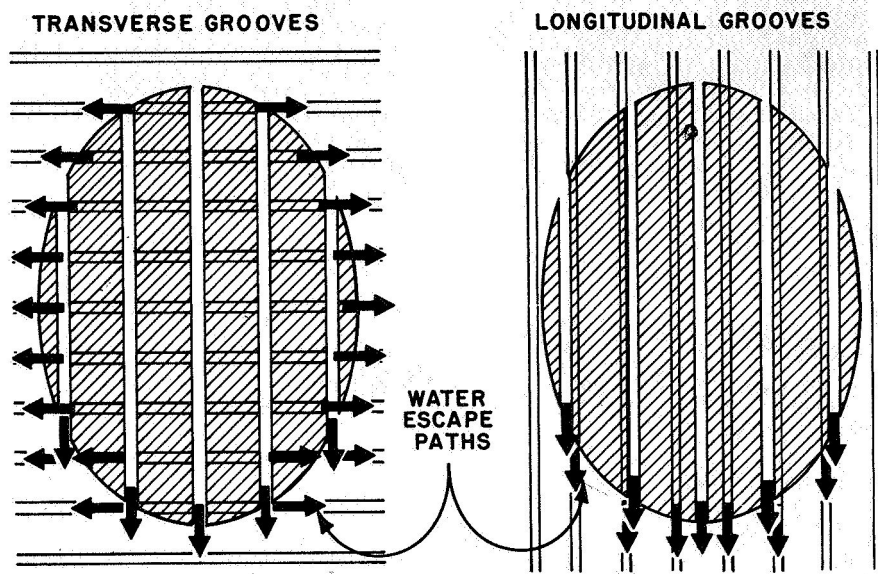

Figure 7.- Treaded footprint.

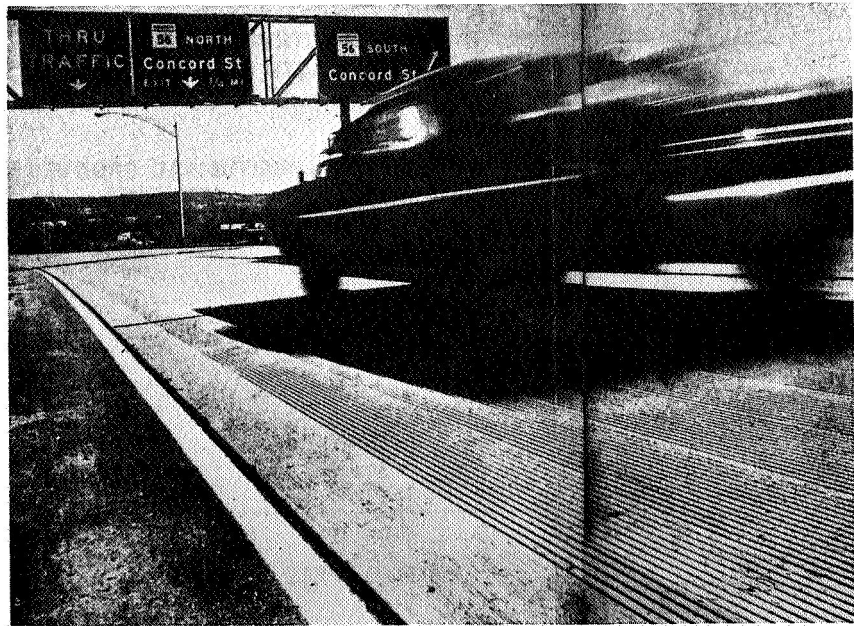

Figure 8.- Grooved pavement in St. Paul, Minnesota.

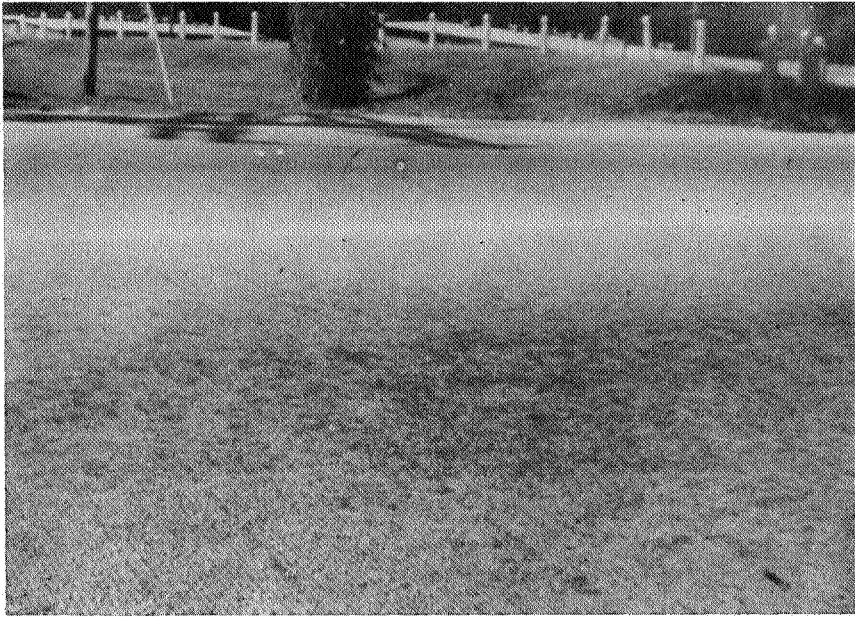

Figure 9.- Grooved pavement in St. Louis, Missouri.

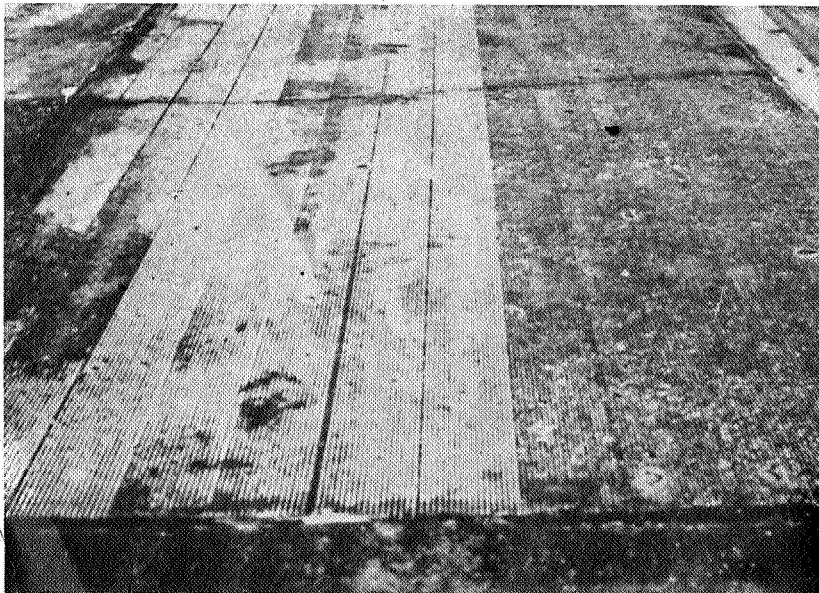

Figure 10.- Irregularities in longitudinal grooves.



Figure 11.- Alined grooving pattern.

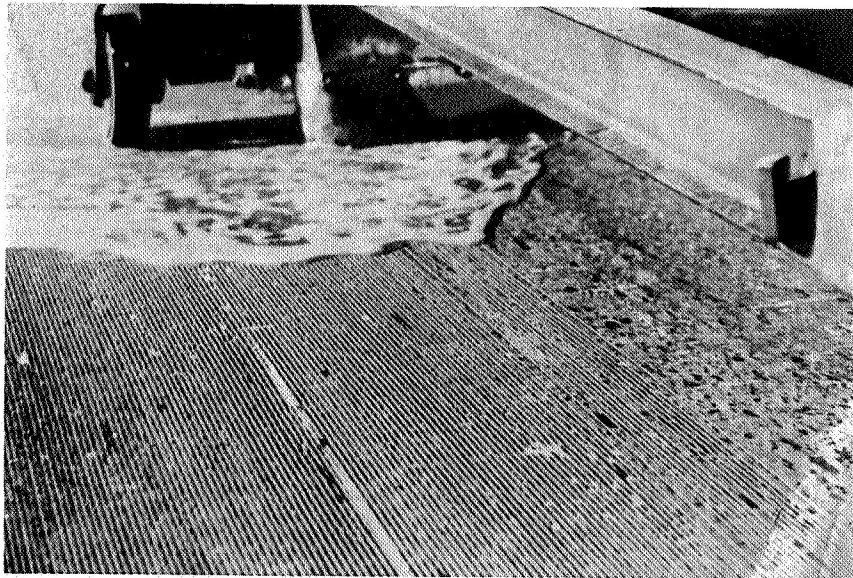

Figure 12.- Slurry.

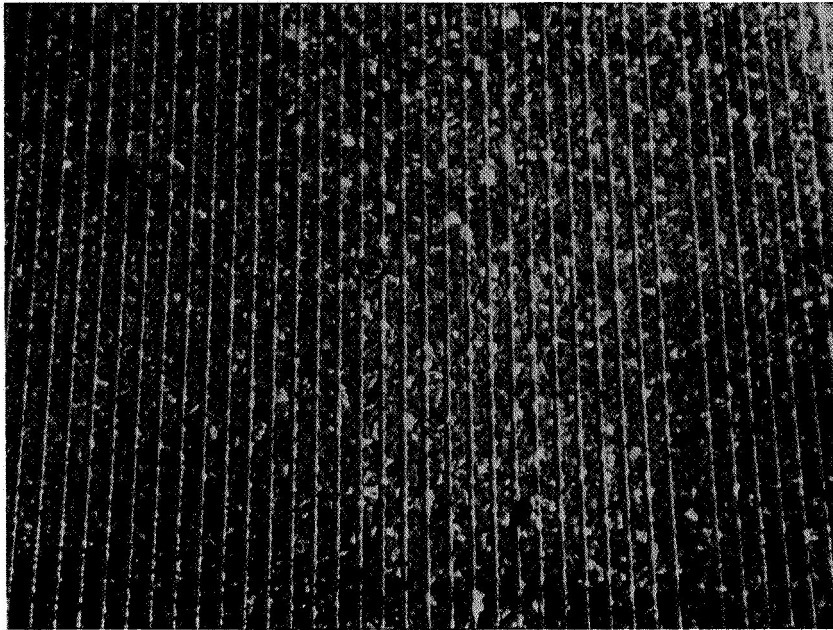

Figure 13.- Clean pavement.

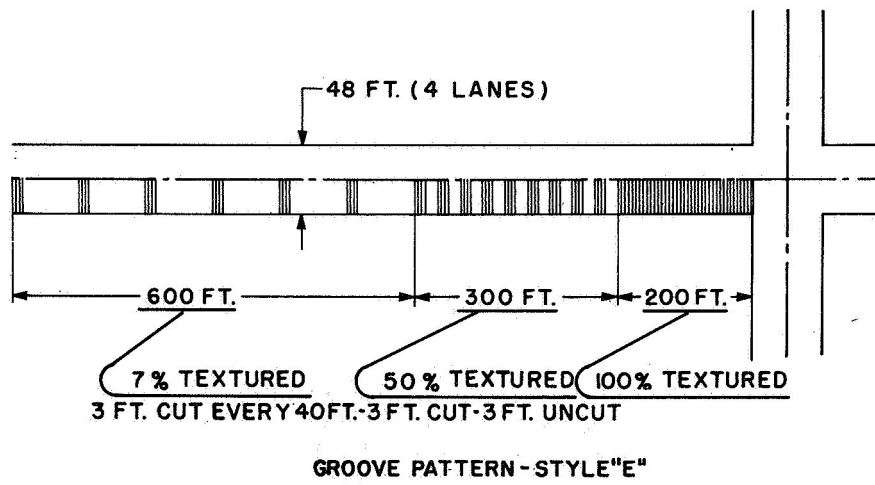

Figure 14.- King Street intersection in St. Augustine, Florida.

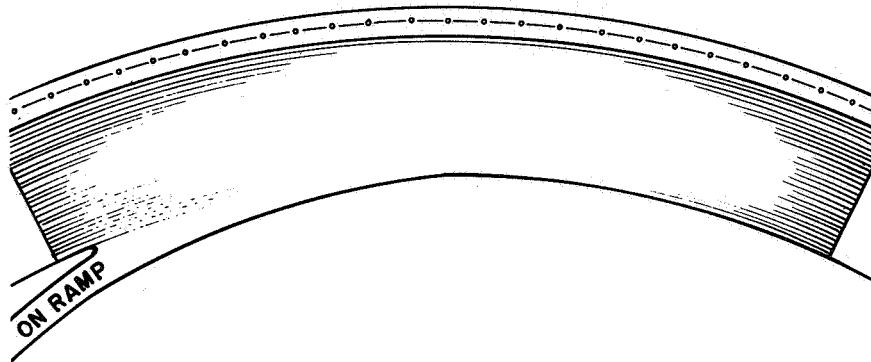

Figure 15.- Longitudinally grooved curve.

