

Ma. Vietnam
1969

N69-30820

NASA CR-66793

PROGRAM TO PRODUCE A FLIGHT PROTOTYPE
COLD CATHODE QUADRUPOLE MASS SPECTROMETER

By J. R. Roehrig

Distribution of this report is provided in the interest of information exchange. Responsibility for the contents resides in the author of organization that prepared it.

Prepared under Contract No. NAS1-5347 Task 14
NORTON RESEARCH CORPORATION
Cambridge, Massachusetts

for

NATIONAL AERONAUTICS AND SPACE ADMINISTRATION

**CASE FILE
COPY**



ABSTRACT

A complete cold cathode quadrupole mass spectrometer system has been constructed as a flight prototype. The spectrometer and electronics is packaged as a single unit and weighs four pounds 13 oz. The system operates from a 28 volts dc source at an average power of 5.25 watts with a mass range of 1 - 50 amu and a resolution of 1 amu in the pressure range of 10^{-8} to 10^{-4} Torr. The mass range may be scanned in five seconds or slower as required. Possible future improvements are also discussed.

TABLE OF CONTENTS

	Page
INTRODUCTION.....	1
SPECTROMETER TUBE.....	2
ELECTRONICS.....	9
RF Generator.....	9
RF and Sweep Control Circuits.....	11
DC to dc Converter.....	11
Logarithmic Electrometer.....	14
SYSTEM OPERATION.....	14
FUTURE DEVELOPMENT.....	21
Hardware Improvements.....	21
Advanced Operational Techniques.....	22

LIST OF FIGURES

Figure #	Title	Page
1	Prototype Quadrupole	3
2	Cold Cathode Ion Source - New Design	4
3	Exploded View of CCIS Quadrupole	6
4	CCIS Quadrupole Prototype on Vacuum System	7
5	Spectrum with Lab (EAI) Electronics	8
6	Schematic of rf Generator	10
7	Schematic of rf & dc Control Circuits	12
8	Schematic of dc to dc Converter	13
9	Prototype Quadrupole with Cover Removed	15
10	Prototype Quadrupole with Open Panel	16
11	Prototype Quadrupole Spectrum at 1×10^{-4} Torr - Air Leak	18
12	Prototype Quadrupole Spectrum at 7.5×10^{-6} Torr - Inert Gas Leak	19
13	Prototype Quadrupole Spectrum at 6.2×10^{-8} Torr - Residual Gases	20

PROGRAM TO PRODUCE A FLIGHT PROTOTYPE
COLD CATHODE QUADRUPOLE MASS SPECTROMETER

By J. R. Roehrig

Norton Research Corporation

INTRODUCTION

During 1967, Norton Research Corporation designed, fabricated and tested a miniature, light-weight cold-cathode source quadrupole mass spectrometer. This "in-house" work drew heavily on the results of Langley-sponsored research under NAS1-2691 in which a cold-cathode source was adapted to a commercial quadrupole spectrometer. Under Task 11 of Contract NAS1-5347 a breadboard miniature electronics package was developed for this spectrometer tube. With the exception of the power budget which was 10% over the required ten watts, this package with the spectrometer tube met or exceeded all of the design goals.

Task 14 under the same contract provided for the construction of a prototype instrument with further development of the electronics to reduce the power, and to redesign the ion source to permit the axial flow of the gases to be measured. The unit resulting from this program is shown and discussed in the following report.

The specifications are as follows:

Weight: 4 lbs. 13 oz.

Power: 5.25 watts (average)

Mass Range: 1 - 50 amu

Resolution: $\Delta m = 1$ amu 10% valley between adjacent peaks

Primary Power: 28 volts dc

Output: 0 - 5 V dc analog

Dynamic pressure range: 10^{-8} to 10^{-4} Torr N_2
equivalent

Sweep time: 5 seconds minimum to > 5 minutes

A photograph of the completed instrument is shown in Figure 1.

SPECTROMETER TUBE

Several major changes were made in the new spectrometer tube assembly. The contract required a change in the entrance port from the side of the tube to one that was coaxial with the spectrometer at the ion source end. Because this would involve some changes in the ion source design a complete redesign of the source was undertaken. Several factors contributed to this decision. A hollow cathode stub as developed under Task 8 of Contract NAS1-5347 would be very desirable to reduce the background noise. A new cylindrically shaped magnet would be very desirable, saving both volume and weight. However, in order to obtain the necessary magnetic field, larger internal pole pieces are required as well as a small reduction in the major diameter of the original ion source tube.

The new design, shown in Fig. 2, incorporates the new magnet and pole pieces, and permits the extraction of the source assembly thru the mouth of the quadrupole assembly. A further saving in volume and weight might be possible if the pole pieces and cathode were made from permanent magnets thus eliminating the external cylindrical magnet completely. This would require a further investigation to obtain the proper field but it looks promising and could save up to one half pound.

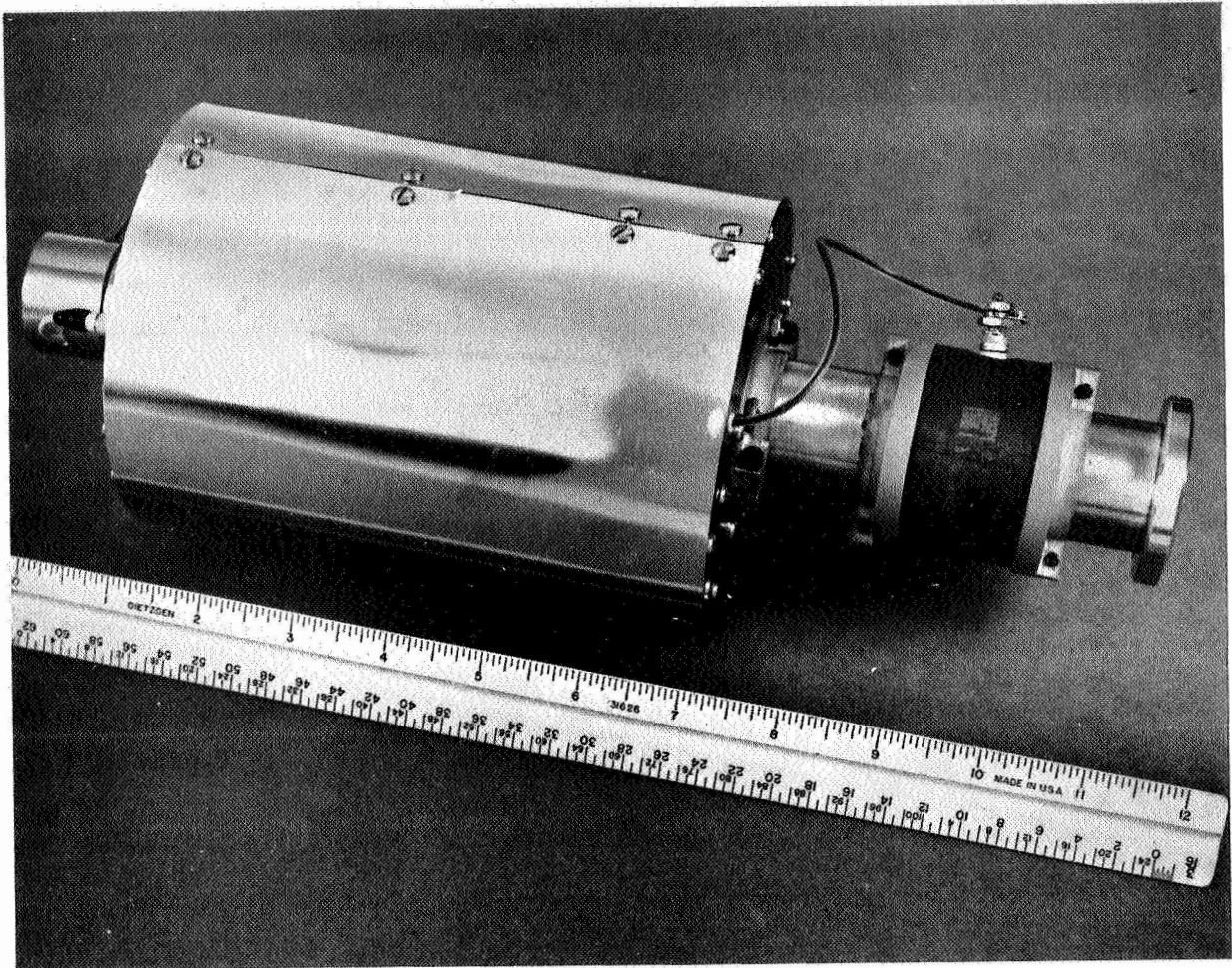

Figure 1. - Prototype Quadrupole

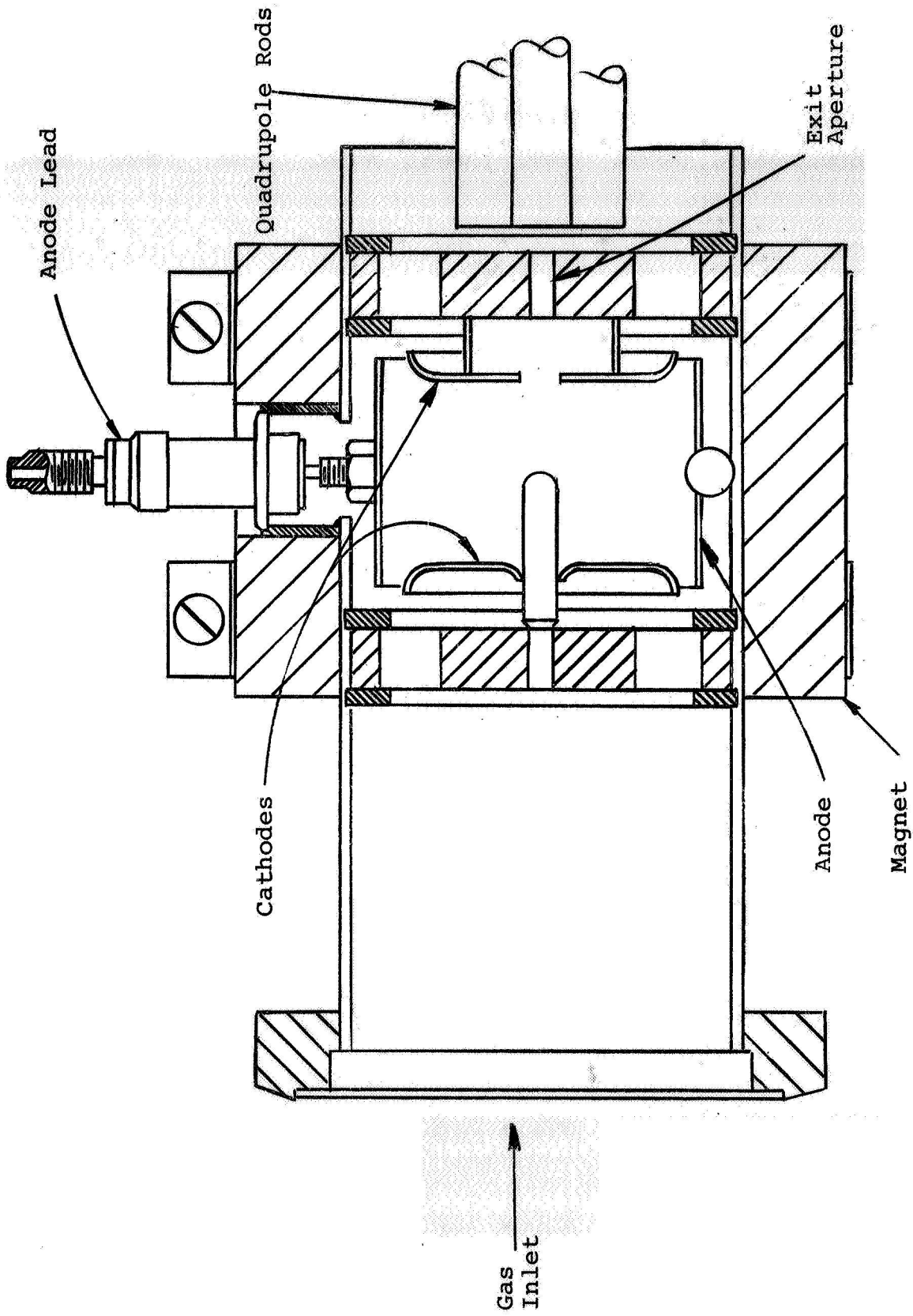

Figure 2. - Cold Cathode Ion Source - New Design

The rest of the spectrometer, the quadrupole and the electron multiplier are the same as in the previous model. The electrical feedthrus were rearranged to more easily mount the electronic package and a small shield cap was added to the electron multiplier end to shield the electrometer lead while bench testing the unit. The electron multiplier was also moved closer to the exit aperture to improve the ion collection at the first dynode. An exploded view is shown in Figure 3 and the assembly on a vacuum system is shown in Figure 4.

The entrance port is provided with a standard Varian conflat rotatable flange for mounting on a vacuum system for test. The large volt ring is cut in half so that it can be removed. This type of mounting would not be used in a spacecraft application so that the bolt ring is not included in the total weight.

The new spectrometer assembly was tested with the laboratory (E.A.I.) electronics on a small unbaked vacuum system. The performance proved even better than the original unit. A typical spectrum is shown in Fig. 5. The resolution peak width is a little less than 1 amu at the 10% valley point and the sensitivity is approximately one order of magnitude better. The noise background is also improved by at least a factor of ten. This is attributed to the hollow cathode stub included in the design.

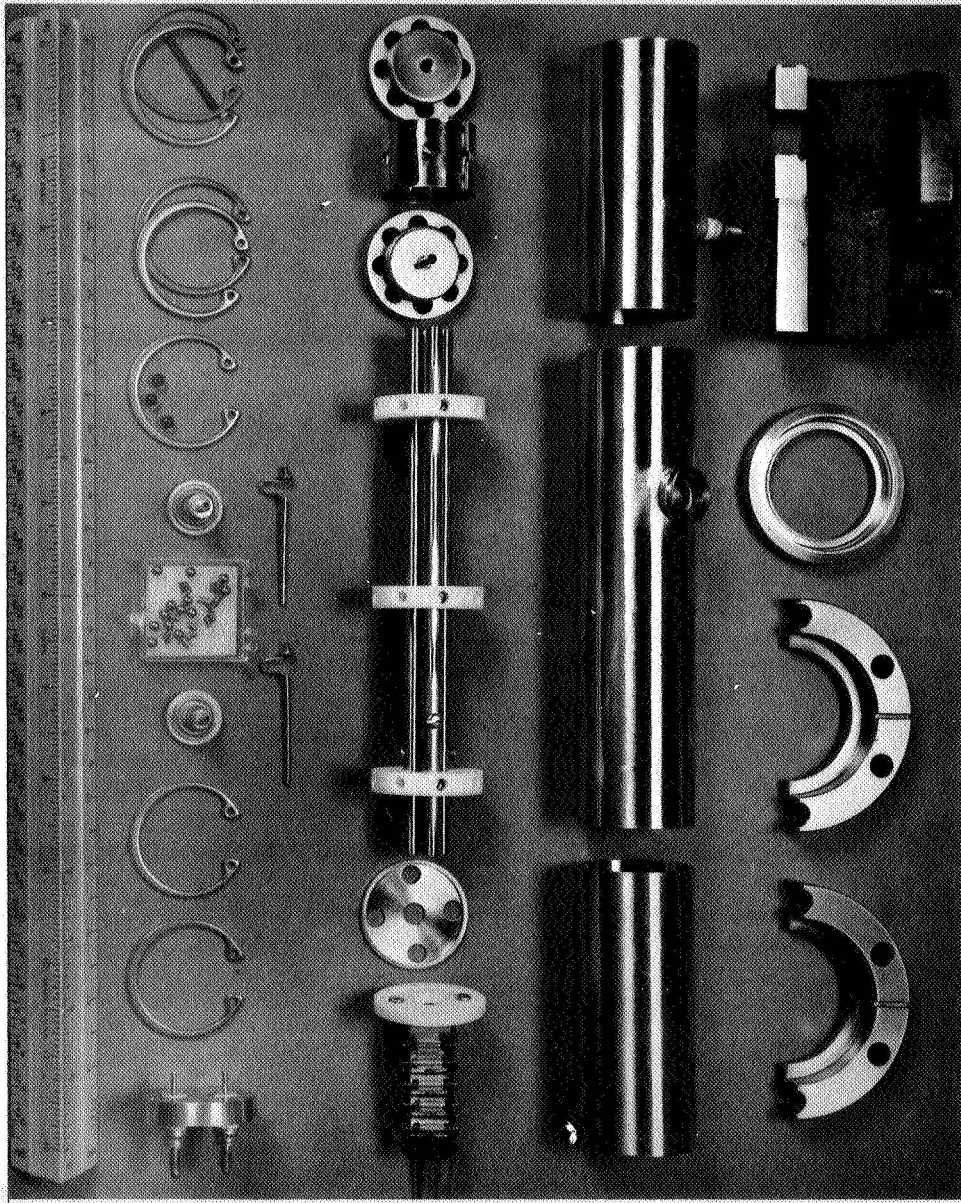

Figure 3. Exploded View of CCIS Quadrupole

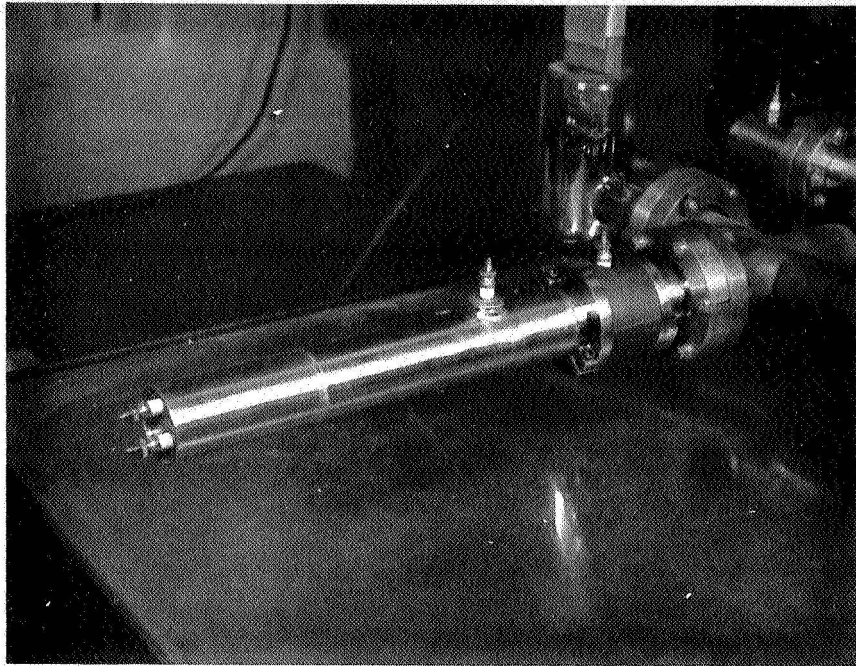

Figure 4. - CCIS Quadrupole
Prototype on Vacuum System

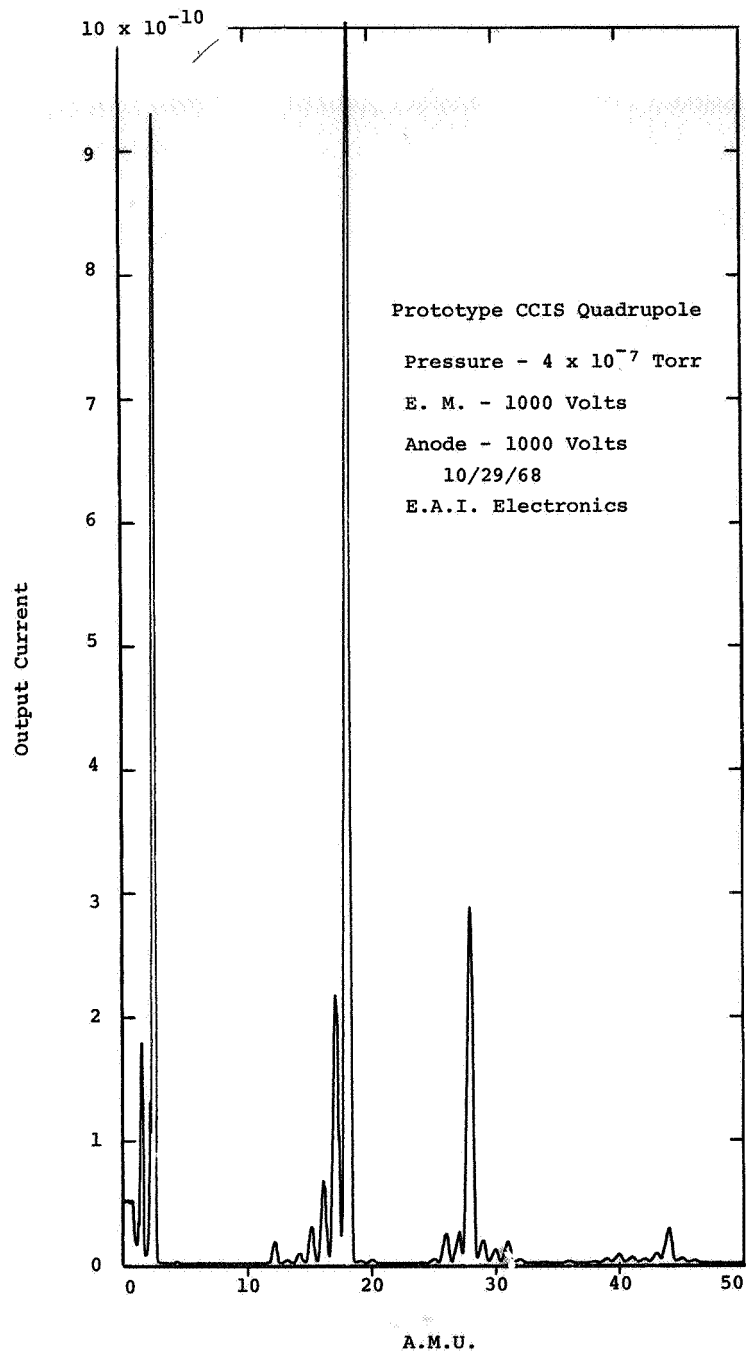

Figure 5. - Spectrum with Lab (EAI) Electronics

ELECTRONICS

Although the breadboard electronics developed under Task 11 operated satisfactorily, several areas were open for improvement, particularly from the standpoint of power. The rf generator appeared to be very inefficient as was the dc to dc converter-power supply. The control circuitry could also be improved by increasing the gain in the amplifiers for better stability.

RF Generator

The standard rf power calculation for the quadrupole predicts a requirement of about 5 watts at mass 50 with a tuned circuit Q of 200 and a frequency of 6 MHz. The breadboard model required an input power of 11 watts (average) to sweep to mass 50. Although the Hartley oscillator circuit is straightforward, the efficiency will depend on the impedance match to the tuned circuit, the feedback, and the tuned circuit Q. After experimenting with a ferrite core designed for 6 MHz, other cores were obtained and the Q's measured. A dramatic increase in Q was obtained with a core recommended for frequencies above 20 MHz. The measured value of the unloaded Q of the original core was 200 - 250, the new core measured 450. With the new core the rf generator required an input of only 3.5 watts to sweep to mass 50. This, of course, drastically cut the total power requirement. Some weight reduction was also obtained since a small core was found to be usable. The final circuit is shown in Figure 6.

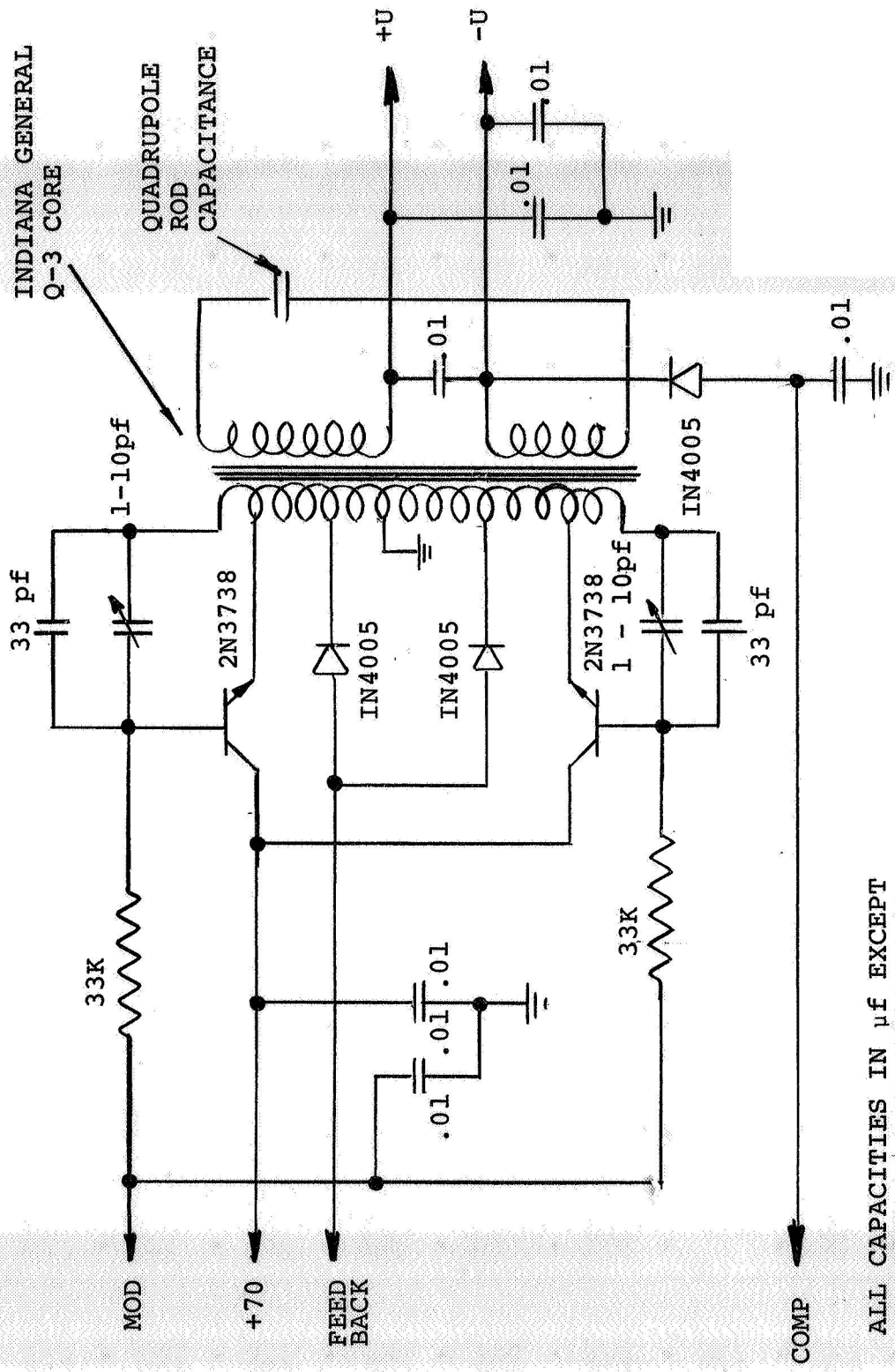

ALL CAPACITIES IN μ f EXCEPT AS NOTED ALL RESISTORS 1/8 WATT

Figure 6. - Schematic of rf Generator.

RF and Sweep Control Circuits

The major problems in the control and sweep circuits were power and stability. The main approach on stability is to increase the gain in the feedback loops for tighter control. If more stages are added to the present amplifier circuits, power and weight requirements will increase. The three discrete component amplifiers can be replaced with integrated circuit operational amplifiers with a dc voltage booster stage added. A large voltage gain is then obtained at low level, saving both power and weight. The circuits were completely redesigned to use Motorola IC operational amplifiers. Because the logarithmic electrometer operates from + and - 15 volt power the same regulated power supply can be used for these amplifiers. The new circuit shown in Figure 7 provides much improved tracking of the U/V ratio and dc balance with reduced power and weight.

Dc to dc Converter

In the breadboard model the electrometer amplifier operated directly from the 28 volt buss through its own dc to dc converter. This of course wasted some power and it was anticipated that this would be combined with the main power supply in a prototype model. Other areas for improvement were the starting circuit for the switching transistors and the voltage regulators. The final circuit which includes two integrated circuit voltage regulators is shown in Figure 8. Approximately one watt was saved in the redesign.

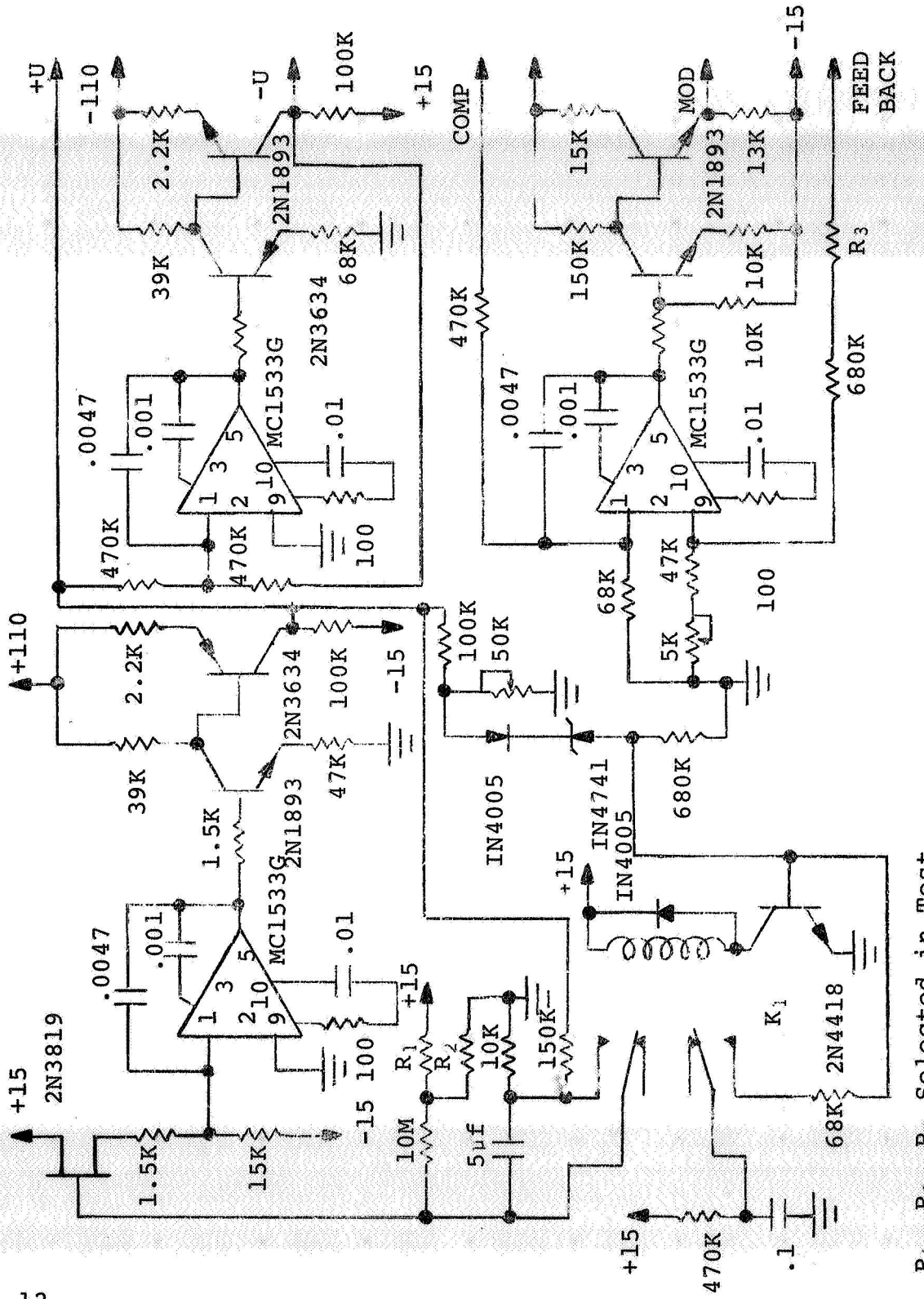
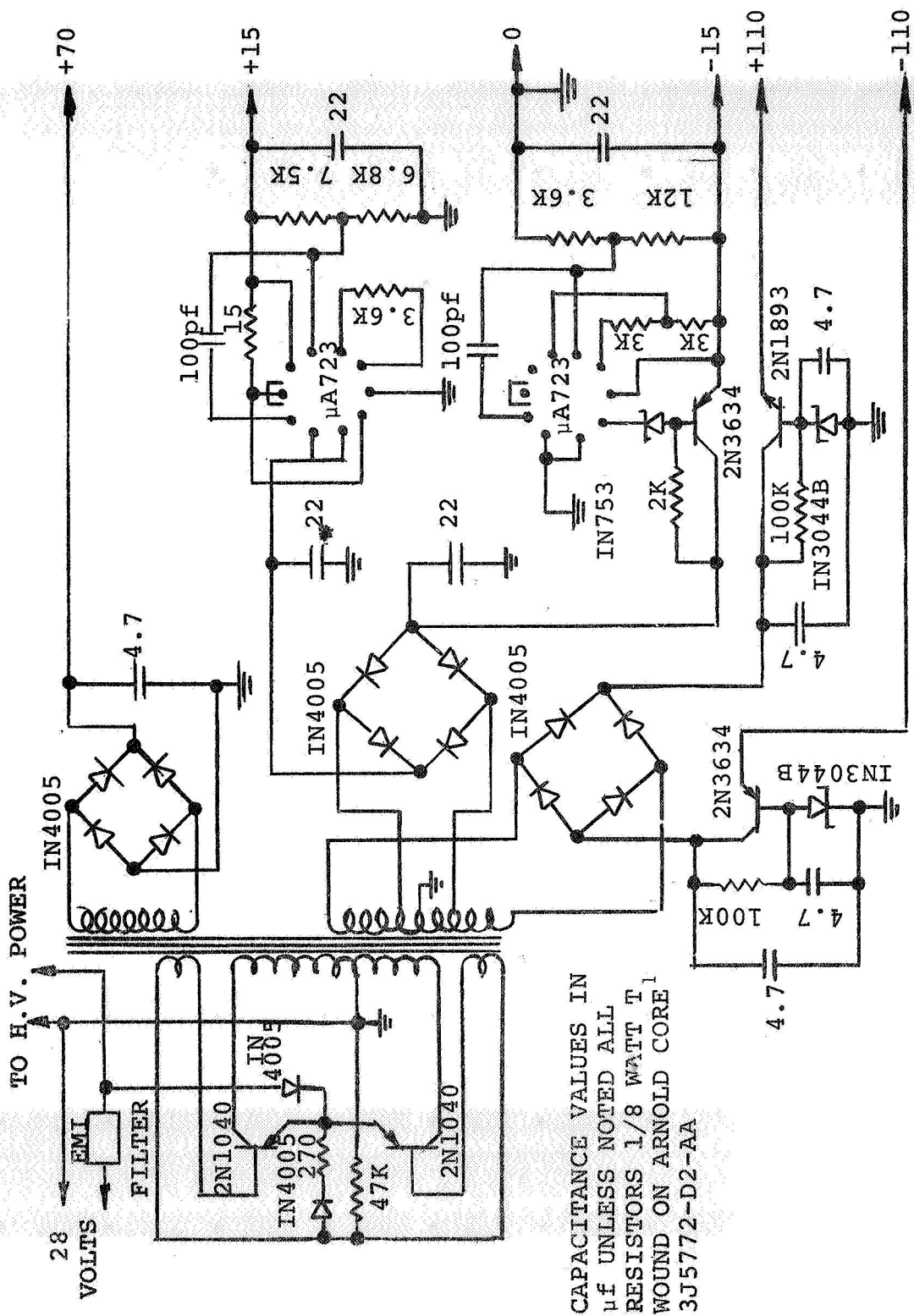

Figure 7. - Schematic of rf & dc Control Circuits

R_1 , R_2 , R_3 Selected in Test



CAPACITANCE VALUES IN
 µf UNLESS NOTED ALL
 RESISTORS 1/8 WATT T₁
 WOUND ON ARNOLD CORE
 3J5772-D2-AA

Figure 8. - Schematic of dc to dc Converter

Logarithmic Electrometer

The Keithley unit used in the breadboard is also used in the prototype. The circuit board was trimmed to fit a new shielding box in the electronics package. Capacitor type feedthrus were added to the power and output leads to prevent stray rf from entering the shield. The input lead is, of course, shielded and runs directly from the spectrometer to the coaxial plug on the electrometer housing.

SYSTEM OPERATION

The electronic system is mounted in a circular housing surrounding the spectrometer tube as shown in Figures 9 and 10. This provides short leads for the rf generator and the electrometer input and makes a reasonably compact package. Four struts support the four major subsystems and the two Velonex high voltage power supplies are mounted on the end plates. The end plates are clamped to the spectrometer with split ring clamps at either end for easy removal of the electronics. In a final flight model the end plates could be welded to the spectrometer body for better rigidity.

The only real problem encountered with the packaged electronics was the close association of the ion source magnet and the rf generator coil. The stray magnetic field saturated the core of the coil. This reduced the frequency and increased the power required to sweep mass numbers above mass 30. Although several types of magnetic shields were tried the best solution was found to be a small disk of magnetic material mounted near the coil. This distorted the stray field

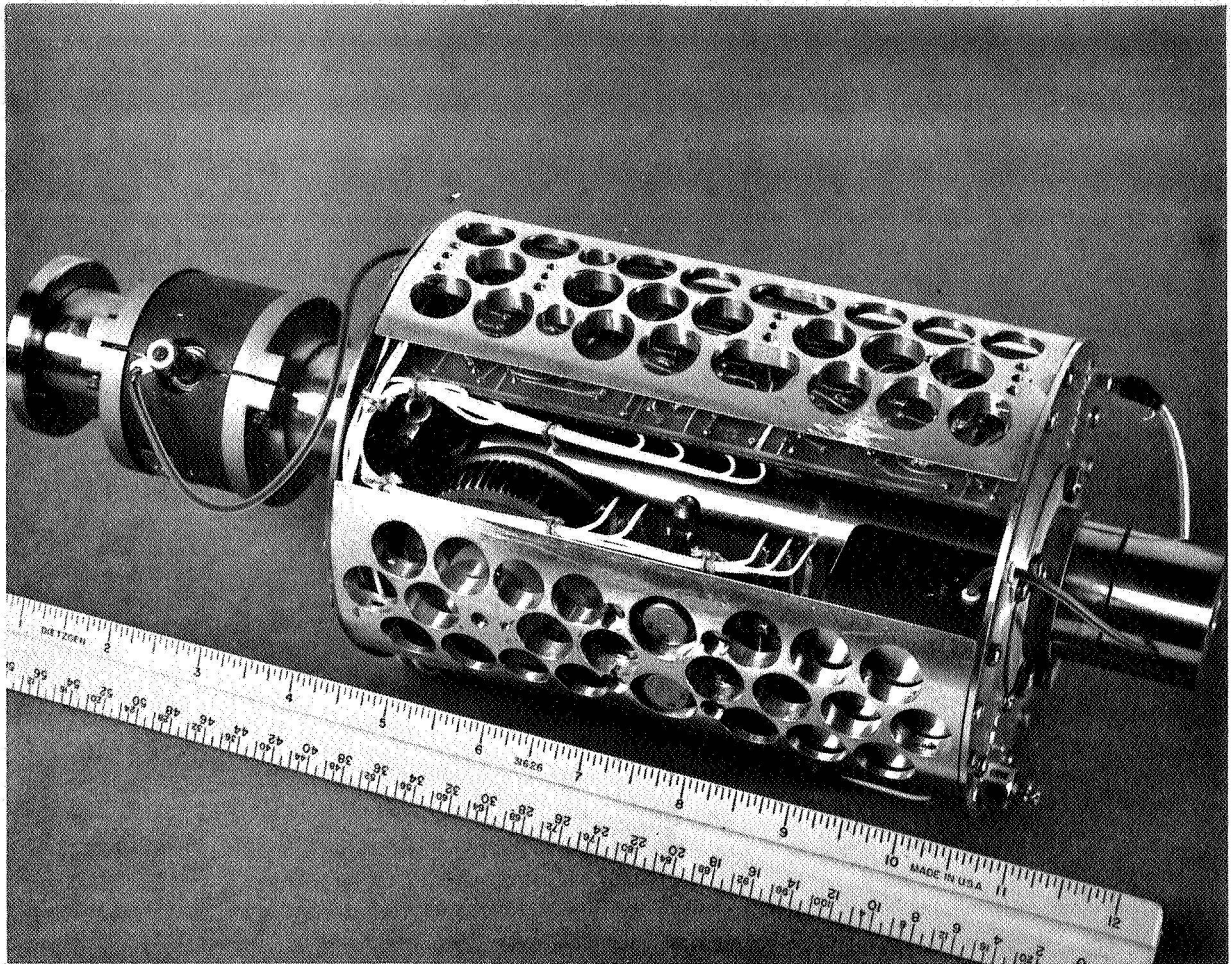

Figure 9. - Prototype Quadrupole
with Cover Removed

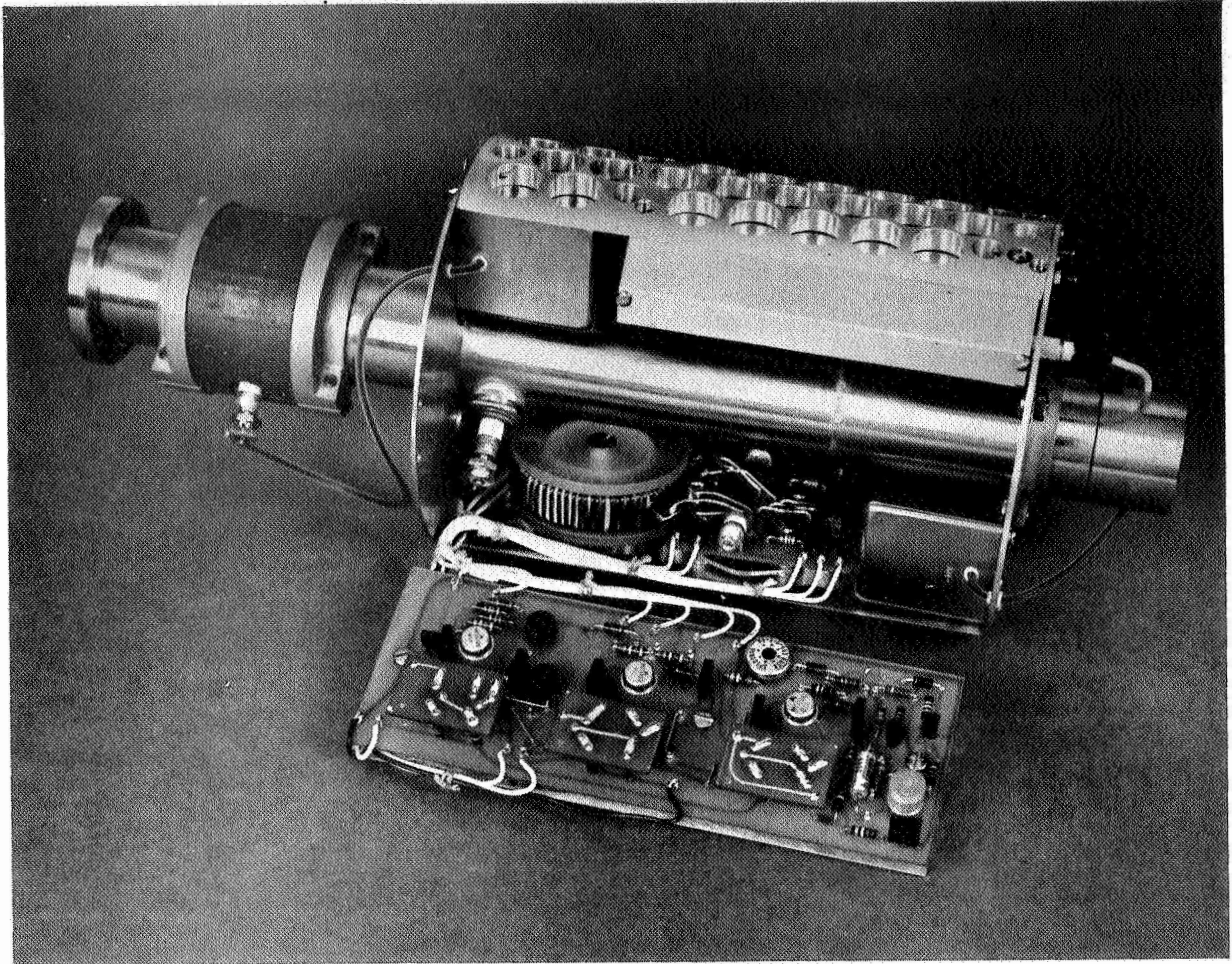

Figure 10. - Prototype Quadrupole
with Open Panel

enough so that the coil no longer saturated and the frequency returned to normal. In any future instrument the rf generator can be mounted further away from the magnet and the feedthrus to the quadrupole rods moved to the new coil location.

Typical spectra with a slow scan are shown in Figures 11, 12 and 13 over the operating pressure range. The display is logarithmic as opposed to the previously shown test of the quadrupole with the commercial electronics which is presented as a linear response. The logarithmic display presents greater information including many more peaks and the absolute background level. The resolution shown is better than 1 amu at the 10% valley point and the sensitivity is .01 amps/Torr for N₂. A typical 5 second scan is shown in the photograph of Figure 14 the vertical scale is one decade per division and the horizontal scale is 5 amu per division. It is somewhat compressed in the vertical scale compared to the recorder trace in the slow scan spectrum.

A significant power and weight reduction in power has been made. The average power has been reduced from 11 watts to 5.25 watts and the peak power from 20 to 7.5 watts. The weight improvement is not as large since the breadboard weight did not include the electronic packaging hardware. This addition compensated for the reductions obtained in the rest of the system. Total weight is 4 lbs. 13 ounces a reduction of 2 oz. from the breadboard model.

A complete set of specifications is given in Table 1.

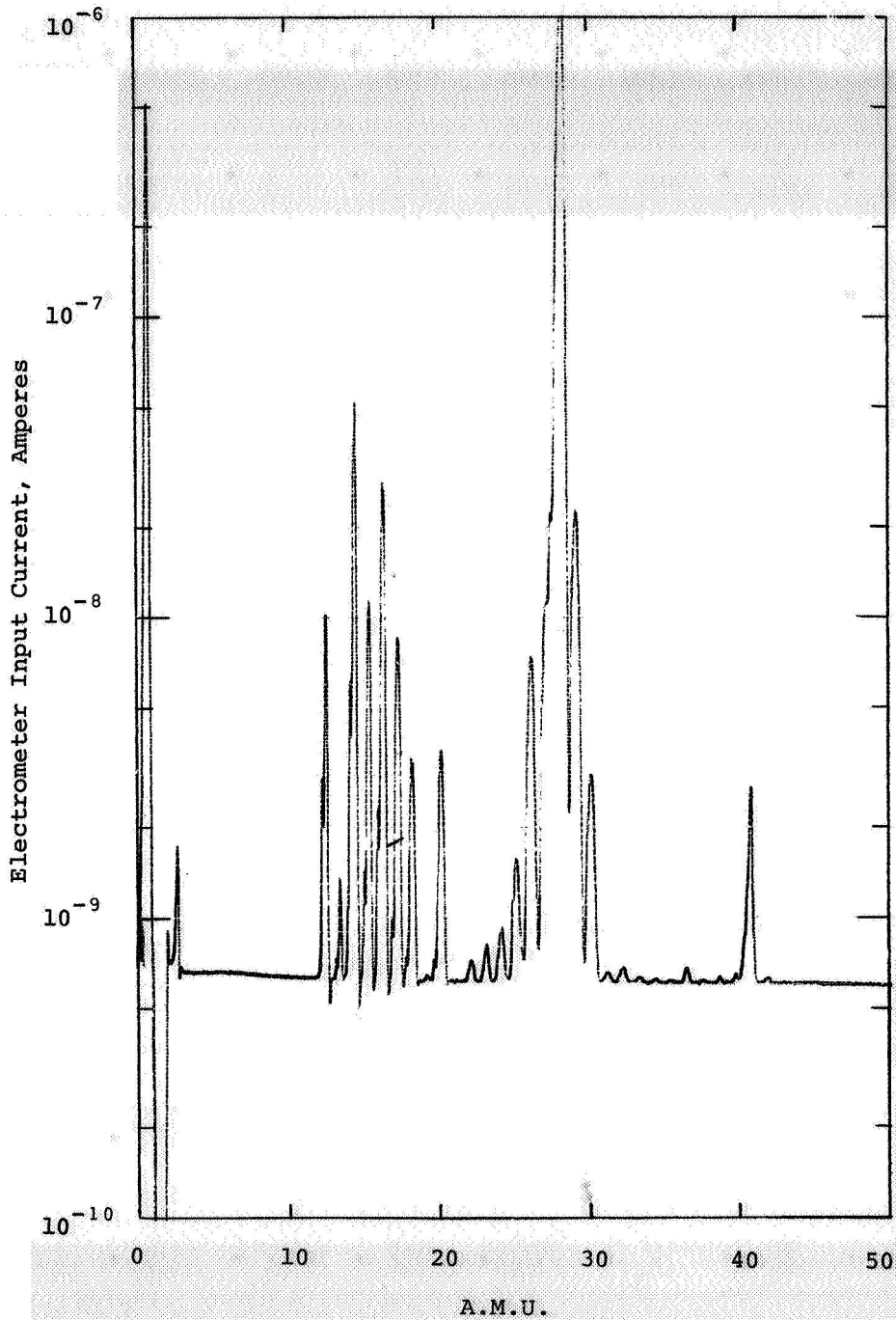

Figure 11. - Prototype Quadrupole Spectrum
at 1×10^{-4} Torr - Air Leak

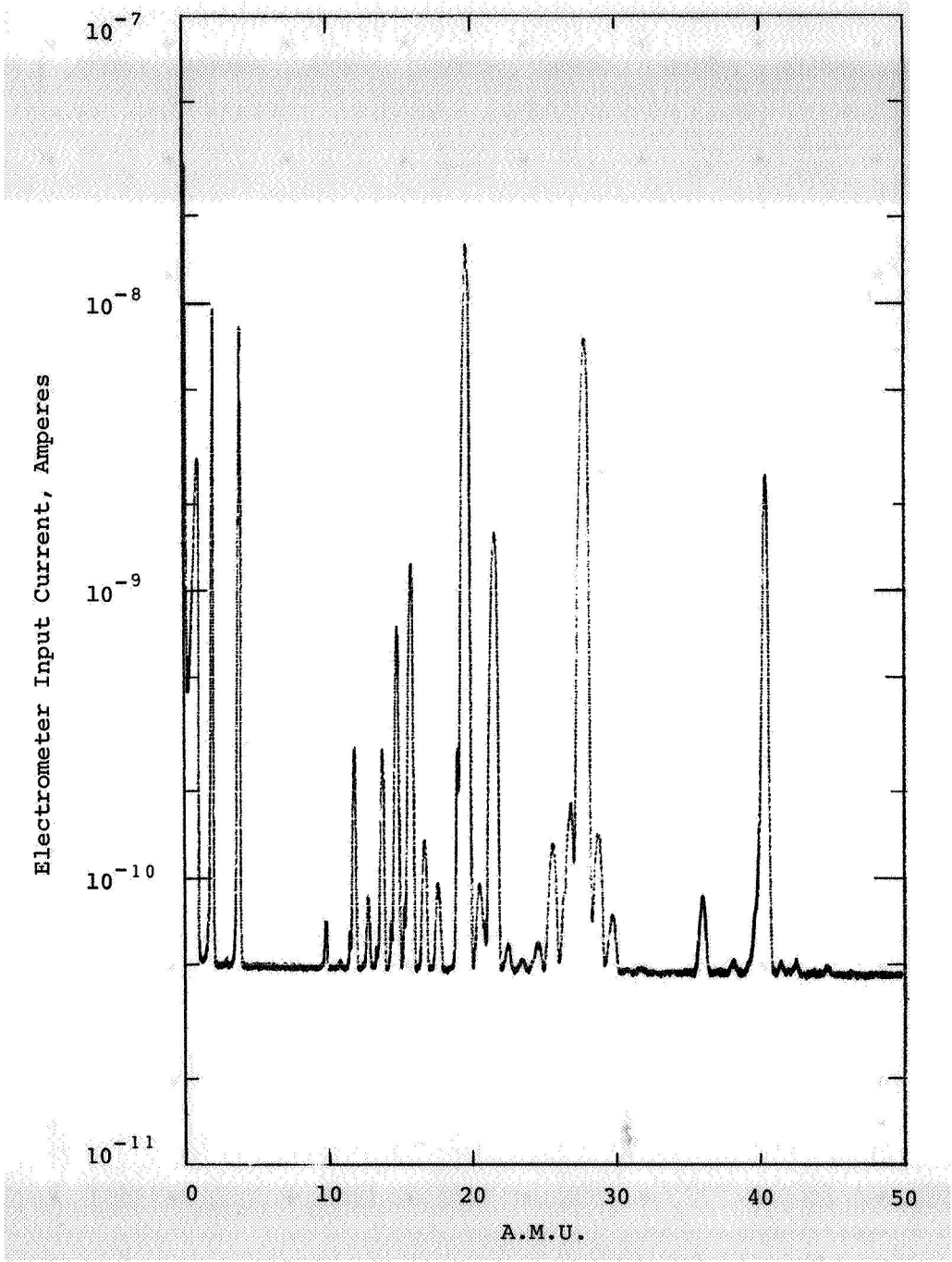

Figure 12. - Prototype Quadrupole Spectrum
at 7.5×10^{-6} Torr - Inert Gas Leak

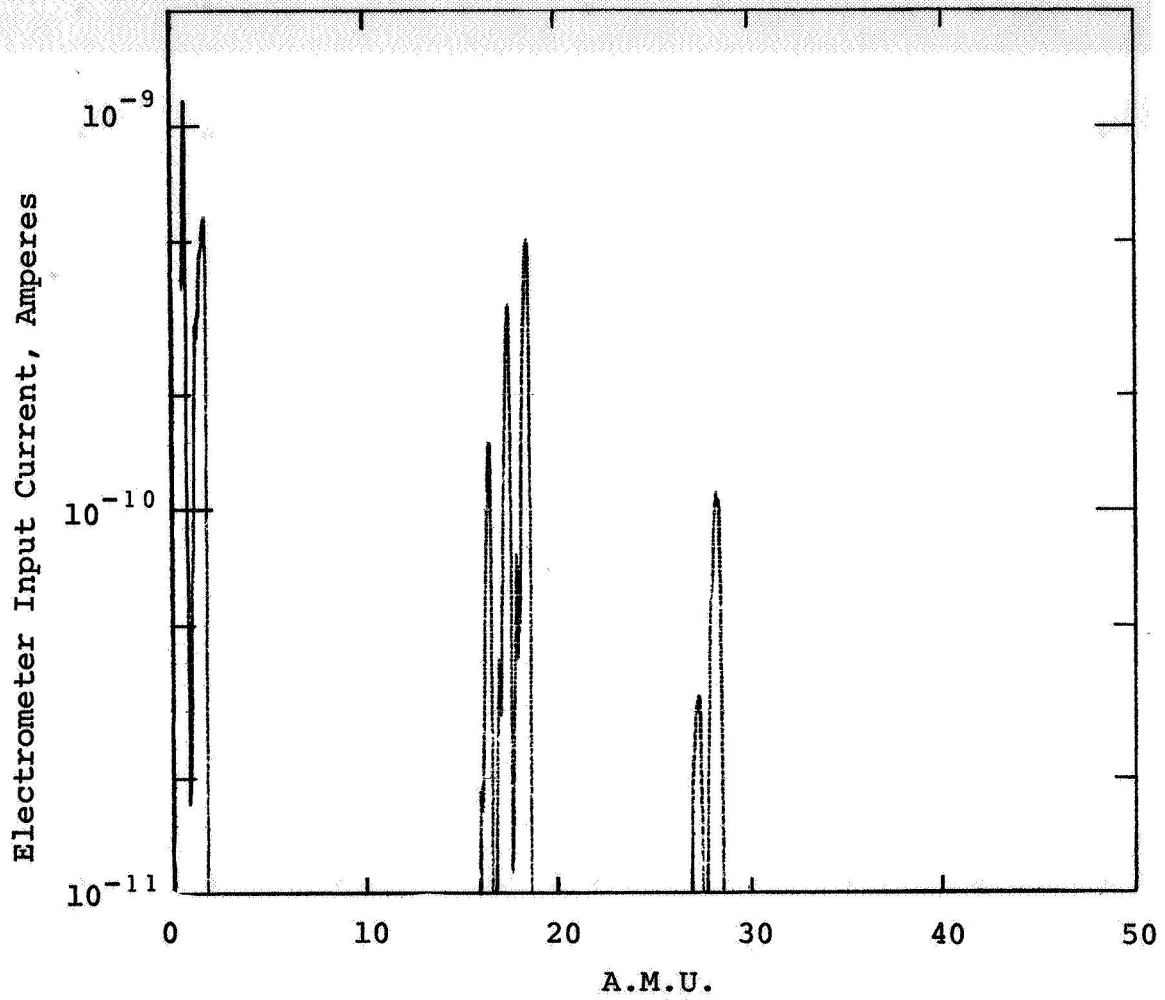

Figure 13. - Prototype Quadrupole Spectrum
at 6.2×10^{-8} Torr - Residual Gases

FUTURE DEVELOPMENT

Hardware Improvements

As with most developmental programs several new ideas for improvement grew out of this task which could not be foreseen at the beginning of a task whose development was limited by time and funds. It is an evolutionary process. There are a number of areas in which further work would bring improvements. As indicated previously the ion source magnet is the heaviest single item so that an investigation of the possibility of including the magnet in the internal structure where, because of the reduced air gap, the volume of the magnet could be reduced. The magnet now weighs 15 oz. with its mounting hardware. This could probably be reduced by 8 - 10 oz. Some of the sections of the spectrometer tube could be reduced in thickness without weakening the whole structure. The electronics package is also open to some weight reduction. Additional savings in weight in the electronics circuits would probably be small although the power transformer could be smaller and the high voltage power supply cases are unnecessary. In all a weight-improvement of about one pound could be made in another model.

Possibilities for power savings are not too extensive although a more intensive investigation of the power losses should be rewarding. Incorporating the two high voltage supplies into the main supply is one possibility. Better isolation of the components from the magnet (as previously discussed) and from the rf field will also help. In all it may be possible to save about one watt.

Many of these improvements can be incorporated in a succeeding model without too much trouble but others will require a more extensive development.

Advanced Operational Techniques

In a companion development program (Task 16) the use of ion counting techniques has been investigated in conjunction with a laboratory CCIS/Quadrupole spectrometer. This program, which emphasized S/N ratio and detector stability improvements, has been quite successful. Therefore, in considering future design improvements, the ion counting approach should be considered. The following discussions outline certain approach details and the advantages which could result therefrom.

The CCIS/Quad developed under Task 11 and 14 uses the multiplier on a dc analog basis. Under present circumstances the gain of the multiplier need only be of the order of 10^3 . In fact, if the gain were any higher, the output current in the multiplier would be so large at 10^{-4} Torr that fatigue of the multiplier would result. A gain of 10^3 is too low to employ counting techniques, because a gain of 10^6 or better is required to produce pulses large enough to count with 100% efficiency. In fact, to even consider a counting detector the sensitivity of the CCIS/Quad must be reduced by some 3 or 4 orders of magnitude to prevent complete fatiguing of the multiplier.

Since sensitivity and resolution are inversely related the excess sensitivity may be traded for improvements effecting resolution, power and/or transmission. For instance, if r_0 is reduced substantially, the power decreases as $(r_0)^4$ as shown by the following equation:

$$P = \frac{6.5 \times 10^{-4} \text{ CM}^2 v^5 r_0^4}{Q}, \text{ watts}$$

where C is the total rf tank circuit capacitance (in pf) including the quadrupole, M is the ionic mass in amu, v is the rf frequency in MHz, r_0 is the radius of the circle (in CM) inscribed within the rods and Q is the figure of merit of the tank circuit.

The reduction in r_0 has another very salutary effect in the reduction in the peak rf voltage (v held constant) as shown by:

$$V = 7.219 M v^2 r_0^2, \text{ volts}$$

where V is the peak value of rf required to scan mass M. As V is reduced, the corresponding dc rod potential, U, must also be reduced to maintain constant peak width, ΔM , since the resolving power ($\frac{M}{\Delta M}$) is defined

$$\frac{M}{\Delta M} = \frac{0.126}{0.16784 - U/V}$$

The reduction in the maximum values of U and V will be apparent in a reduction in size and weight of the dc to dc converter and rf output transformers.

Recognizing that a large amount of sensitivity must be traded off, the diameter of the quadrupole entrance aperture (d_o) will be reduced so that,

$$d_o = 0.8 \frac{\Delta m}{m} r_o, \text{ cm where } \frac{\Delta m}{m} = \frac{1}{50}$$

This will place the quadrupole in a 100% transmission mode so that the transmission of all ions from 1-50 amu is independant of mass. This important advantage will be discussed shortly, after considering one more important design change, namely the length L (in meters) of the quadrupole rods. It has been found experimentally that the maximum axial injection momentum U_a for proper mass selection is given by

$$U_a \approx 2.1 \times 10^2 v^2 L^2 m \left(\frac{\Delta m}{m} \right), \text{ volts}$$

Assume that the rod length L is reduced by a factor of two (from 6 inches to 3 inches). The advantage of size reduction is readily apparent. The above equation simply states that the reduction in length will require a reduction in maximum axial ion momentum by a factor of four if the peak width, Δm is to remain the same. The reduction in axial momentum can be obtained by reduction in anode voltage, by ion retardation and by reducing the ion exit aperture from the CCIS. Also, the ion energy decreases slightly with increasing pressure. In brief, the required reduction in U_a will probably result from the reduction in d_o suggested above. Alternate methods may also be chosen as noted.

The work performed under Task 16 has shown that an ion counting detector can be designed which is remarkably insensitive to large changes in multiplier gain. Moreover, the detector appears to be much less sensitive to ionic mass, species and other effects. If the quadrupole is operated in the 100% transmission mode as suggested above, the interpretation of peak height vs partial pressure data will only be a function of the ion source sensitivity since neither the analyzer or the detector will be mass sensitive.

The 100% transmission mode has other advantages particularly because of the trapezoidal peak shape. With the resultant flat-topped (nearly) peak, scanning of the entire peak is unnecessary in order to determine the full peak height. The bit rate requirements are therefore reduced and the scanning circuit merely steps over portions of the spectrum where no peaks are likely to be present.

Another advantage is the improved S/N ratio resulting from the Task 16 work. This relates to improved lower limits of detectability for very small concentrations of certain gases in the presence of much larger concentrations of other gases. Detectability of better than 100 parts per million appears possible with the use of counting techniques.

In summary, by purposely trading off sensitivity, a CCIS/Quadrupole spectrometer can be built with some remarkable properties such as:

1. Detector and analyzer will not contribute in any substantial way to the sensitivity vs mass. All ions entering the quad will be detected and counted.

2. Power and rf voltage can be reduced.
3. Size and weight can be reduced.
4. Mass scanning will not be required, so that bit rate requirements will decrease.
5. Improved lower limit of detectability through increased S/N ratio.
6. Log amplifier drift eliminated by counting vs dc detection.
7. The detector will be nearly insensitive to gain changes in the multiplier.

TABLE I

Typical Specifications

Low Voltage Power Supply

Input

Voltage	28 Vdc
Current	185 ma. Avg.

Outputs

+ dc sweep	+ 110 Vdc	
Inverter	- 110 Vdc	
RF control amp	± 15 Vdc	
RF generator	+ 70 Vdc	0-110 ma.
Anode HV supply	Input + 28 V	10 ma. Output + 1000 V
E/M HV supply	Input + 28 V	20 ma. Output - 1000 V

Sweep Generator

Supply Voltages

+ 110 Vdc

- 110 Vdc

Outputs

+ U 0 - +95 Vdc

- U 0 - -95 Vdc

0 - 20 Vdc

Sweep Ref

TO RESET CKT

Sweep Time

Variable <5 sec to 10 min.

RF Control Amplifier

Supply Voltages

± 15 Vdc

+ 110 Vdc

Output

0 - 45 V

RF Modulation Voltage

RF Generator

Supply Voltages

+ 70 Vdc 0 - 110 ma.

Output

0 - 50 V

RF Amplitude Det

+ (U + V cos ω t)

U = 0 - 95 V

- (U + V cos ω t)

V = 0 - 560 Vac pk
freq. 6 MHz.

Log Electrometer Amplifier

Supply Voltages	+ 15 Vdc	1.8 ma.
	- 15 Vdc	1.8 ma.
Range	10^{-11} to 10^{-5} ampere	
Output Resistance	< 1 K	
Response Speed	One millisecc for a step change from 10^{-9} to 10^{-8} ampere	
Output Voltage	0 - 5 Vdc	

Quadrupole

r_o	2 mm
rod length	15 cm
d	.089 in (2,26 mm)
Capacitance	22.5 pf
Q	\approx 200
Magnet	845 G
Weight	2 lb. 8 oz.