

GENERAL OCEANOLOGY, INC.

27 MOULTON STREET  
CAMBRIDGE, MASS. 02138  
TELEPHONE (617) 492-6300

GO REPORT NO. 9

*N69-35947  
NASA CR 101867*

GRAVITY GRADIENT PRELIMINARY INVESTIGATIONS  
FINAL REPORT ON EXHIBIT "A"  
CONTRACT NAS 9-9200

July 31, 1969

Prepared for

NATIONAL AERONAUTICS AND SPACE ADMINISTRATION  
MANNED SPACECRAFT CENTER  
Houston, Texas 77058

**CASE FILE  
COPY**

By

Lloyd G. D. Thompson  
Mark H. Houston  
Daniel A. Rankin



GO REPORT NO. 9

GRAVITY GRADIENT PRELIMINARY INVESTIGATIONS  
FINAL REPORT ON EXHIBIT "A"  
CONTRACT NAS 9-9200

July 31, 1969

Prepared for

NATIONAL AERONAUTICS AND SPACE ADMINISTRATION  
MANNED SPACECRAFT CENTER  
Houston, Texas 77058

By

Lloyd G. D. Thompson  
Mark H. Houston  
Daniel A. Rankin



## ABSTRACT

Preliminary laboratory experimentation with a modified off-the-shelf quartz microbalance and proof masses gave vertical gravity gradient measurements accurate to 90 Eötvös Units and an instrument resolution or sensitivity of 10 Eötvös Units. Most of the measurement error was found to be caused by known local disturbing environmental effects which could be readily eliminated. Improved instrumentation with 1 Eötvös Unit resolution and 5 to 10 E.U. accuracy for field surveys is considered achievable. Under quiet environmental conditions in a special laboratory facility or space vehicle, 0.1 Eötvös Unit resolution and 1 Eötvös Unit accuracy can be expected. This successful use of existing instrumentation for direct gradient measurements is cause for renewed interest in an orbital spacecraft experiment and lunar surface exploration. A portable exploration model gradiometer has immediate application for surface exploration of the earth and moon.

## TABLE OF CONTENTS

<u>Section</u>	<u>Title</u>	<u>Page</u>
I	INTRODUCTION	1
II	INSTRUMENTATION	
	A. The Basic Microbalance	3
	B. Modifications for Use as a Gradiometer	8
	C. Set-up and Operating Procedure	9
	D. Laboratory Test Set-up	16
III	ANALYSIS OF MICROBALANCE GRADIOMETER OPERATION USING PROOF MASSES	19
IV	EXPERIMENTAL PROCEDURES	25
V	RESULTS	
	A. Gradient Measurements	30
	B. Performance Evaluation of Gradiometer	41
	C. Disturbing Effects that Limit Sensitivity in the Laboratory	42
	D. Disturbing Effects Anticipated in the Field	43
	E. Disturbing Effects in Space Vehicle Environment	45
	F. Anomaly Detection Capability of Gradiometer	45
VI	PRELIMINARY CONSIDERATIONS OF MICROBALANCE GRADIOMETER FOR ORBITAL SPACE VEHICLE APPLICATIONS	
	A. General	55
	B. Orbital Operation of Microbalance	56
	C. Possible Instrument/Vehicle Configurations	60
	D. Lunar Surface Gravity Survey Applications	62
VII	CONCLUSIONS	63

## TABLE OF CONTENTS (Cont.)

<u>Section</u>	<u>Title</u>	<u>Page</u>
VIII	RECOMMENDATIONS	66
ACKNOWLEDGEMENTS		70
REFERENCES		71
APPENDIX A	Worden Auto-Null Microbalance Specifications	72
APPENDIX B	Formulas for Calculating Gravity and Gravity Gradient Anomalies	74
APPENDIX C	Gravity Gradient Derivation	77

## LIST OF ILLUSTRATIONS

<u>Figure</u>	<u>Caption</u>	<u>Page</u>
1	Worden Quartz Microbalance Basic Element	4
2	External View Showing Components of Basic Auto-Null Microbalance Assembly	5
3	Microbalance with Mu-metal Shielding and Long Tube Vacuum Enclosure	10
4	Microbalance with Electrostatic and Magnetic Shielding together with Vacuum System	12
5	Complete Microbalance with Fluke Digital Voltmeter Readout and Auto-Null Control Unit.	13
6	Auto-Null Microbalance System as Used for Final Gradient Measurements Showing Millivolt Recorder, Lead Proof Mass, and Gravity Meter	17
7	Microbalance System as Used During Laboratory Tests Showing Various Recording Systems: Millivolt Recorder, Digital Voltmeter, and Storage Oscilloscope.	18
8	Relative Scale of Gradiometer Size to a Geologic Structure and a Proof Mass	20
9	Vertical Gravity Gradient as a Function of Distance from a Sphere	21
10	Strip-Chart Recording of Instrument Response for Cubic Proof Mass Under Normal Observing Conditions.	32
11	Strip-Chart Recording of Measurements Over a Cubic Proof Mass Illustrating Repeatability of Microbalance Response	33
12	Gravity and Gravity Gradient Profiles over 12"x12"x12" Lead Cube and 18"x18"x6" Lead Slab Proof Masses	36
13	Vertical Gradient Anomaly Profile for 5 Subsurface Spheres (from Balavadze)	44

## LIST OF ILLUSTRATIONS (CONTINUED)

<u>Figure</u>	<u>Caption</u>	<u>Page</u>
14	Vertical Gradient Profile over a Two-Dimensional Trapezoidal Body. $h$ is the Height above Ground Level ( $Z = 0$ ).	48
15	Vertical Gradient Profile over a Horizontal Cylinder. $h$ is the Height above Ground Level.	49
16	Vertical Gradient Profile over a Buried Mountain Ridge. $h$ is the Height above Ground Level.	50
17	Vertical Gradient Profile over a Fault Structure. $h$ is the Height above Ground Level.	51
18	Vertical Gradient Profile over an Oceanic-Continental Transition Zone for a 65-km Lunar Orbit.	53
19	Axis Orientation for Orbital Space Vehicle Applications.	55
20	Possible Gradiometer Configurations for Space Vehicle Applications. a) -microbalance, b) -torsion balance, c) -semi-conductor crystal balance	58

## LIST OF TABLES

<u>Table</u>	<u>Title</u>	<u>Page</u>
1	Comparison of Gravity Anomaly, Vertical Gradient, and Gradient Curvature Between a Geologic Sized Mass and a Laboratory Proof Mass	23
2	Summary of Preliminary Gradient Measurements	34
3	Calibration of Microbalance Gradiometer	38



## I. INTRODUCTION

This report covers the results of preliminary experimentation with a microbalance gravity gradiometer performed under Exhibit "A" of the statement of work of Contract NAS 9-9200.

In simplest terms, this phase of the investigation was to modify an "off-the-shelf" quartz microbalance into a vertical gravity gradiometer, to demonstrate that the modified microbalance would respond to gradient anomalies over proof masses then to evaluate the gradiometer in terms of its application to orbital space vehicle experiments.

More particularly, this research was to (1) demonstrate the feasibility of using this type of device for vertical gradient measurements, (2) evaluate the device as a vertical gravity gradiometer, (3) obtain preliminary gravity gradient data and information on measurement techniques, (4) provide a simulation of gravity gradient effects over geologic and topographic features using laboratory proof masses, (5) evaluate disturbing effects that may affect gravity gradient measurements in the laboratory, field or on a space vehicle, (6) provide basic information on gravity gradient measurements to aid in future orbital space vehicle gravity gradient experiments and (7) assess the microbalance instrument for future orbital space vehicle experiments

This research program was based on the current availability of suitable instrumentation not hitherto available, namely, a modified quartz microbalance manufactured by Worden Quartz Products, Inc. (a subsidiary of Ruska Instrument Corporation). Of all the available microbalance instrumentation, this was the only one known which could be suitably modified to make vertical gravity gradient measurements. The application of this instrument to this program was based on previous proprietary research, knowledge, and experience of Dr. Lloyd G. D. Thompson in developing

and modifying this type of instrument as a vertical gravity gradiometer. This previous proprietary research successfully demonstrated that this device could make gravity gradient measurements to a sensitivity exceeding about 10 E.U.\* and, therefore, could be applied meaningfully to this program.

The results of this investigation are demonstratable evidence of the capability of the microbalance gradiometer to detect extremely minute differences in gravity and to measure vertical gravity gradients. No previous instrument has been capable of making measurements of such minute gravitational forces. These results are the first documented measurements of this kind.

The work described in this report satisfies all items of the Contract Statement of Work, Exhibit "A".

---

\* 1 Eötvös Unit = (E.U.) =  $1 \times 10^{-9}$  cm/sec<sup>2</sup>/cm =  $1 \times 10^{-12}$  g/cm  
 $= 3 \times 10^{-11}$  g/ft.

## II. INSTRUMENTATION

### A. THE BASIC INSTRUMENT

The microbalance used in this investigation is a modified Worden Quartz Products, Inc. model 4302 Auto-Null Vacuum Microbalance. Appendix A is the manufacturer's brochure for the conventional instrument available at the time of contract negotiation. The normal use of the microbalance is laboratory weighing of small masses or measuring small weight changes in sample materials.

The heart of the balance is an equal-arm bridge similar in function to the standard chemical balance. It is about five centimeters long and suspended at its center by two fine quartz fibers which serve as frictionless hinges as shown in Figure 1. Though the view of the bridge itself is blocked by the coils of wire, the chamber in which it is enclosed is shown in Figure 2. A hook is suspended from each end of the bridge to support the weights being compared. Following standard nomenclature, the right hand hook is called the "tare" hook and holds the standard weights while the left hand hook is named the "sample" hook and supports the unknown object being weighed. A third hook in the center supports the "sensitivity weight." Weights placed on this hook serve to provide a stabilizing influence on the bridge. As this weight is increased, the bridge goes from an unstable condition (resting against a stop) to a stable condition with, as more weight is added, a decreasing period of oscillation. It is called the sensitivity weight because it governs the sensitivity of the balance, which is defined as the angular change of rest position due to a given weight inequality between the masses being weighed. Each of these hooks is suspended by a fine quartz fiber and the balance bridge itself is constructed entirely of fused quartz.

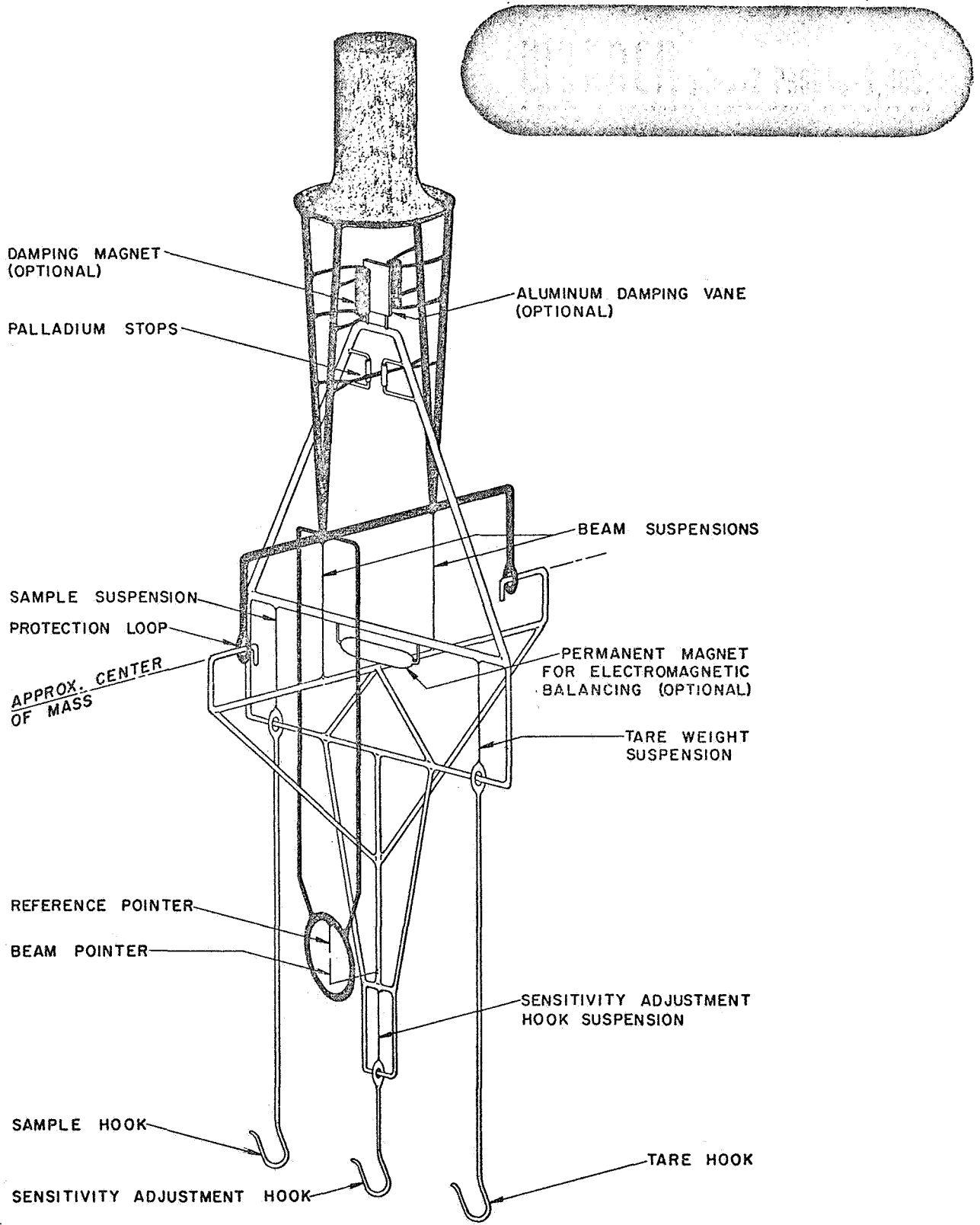

Figure 1. Worden Quartz Microbalance basic element.

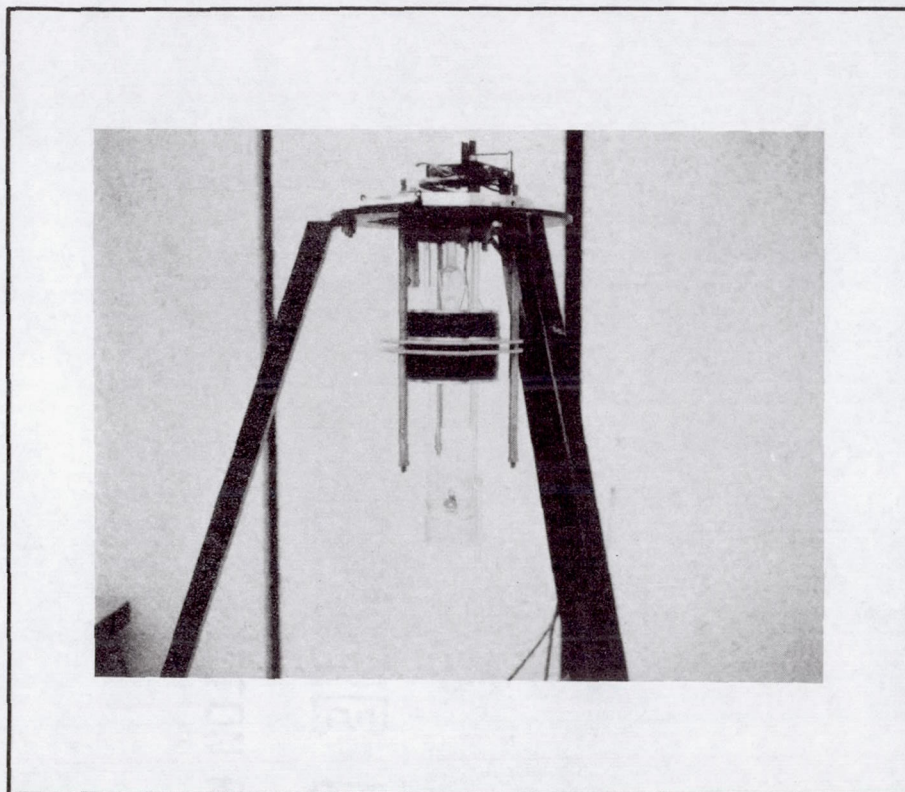

Figure 2. External view showing components of basic auto-null microbalance assembly

Fused quartz is a remarkable substance, its properties being essential to successful functioning of the microbalance hinges. Quartz is extremely strong when drawn into very fine fibers. Such fibers show very low internal friction, no hysteresis, and only slight changes with temperature. Quartz is light in weight, rugged, and has desirable working properties. Because of high strength, quartz balances can support heavy loads (in this case 10 grams on each side) while retaining better than microgram sensitivity.

The bridge and the three hooks are enclosed in a cylindrical pyrex chamber, which is shown in Figure 2. Mounted on the bridge are two objects, a mirror and a small permanent magnet. The mirror is part of an optical lever used to detect the tilt of the bridge. The top of the chamber is a flat plate of glass. A collimated light beam shines through the plate, is reflected from the mirror back through the plate, and falls onto a pair of photo-cells which are placed end-to-end in the arc struck by the reflected light beam. Electrically they are connected in opposition, resulting in zero voltage output when the light beam shines precisely on the junction. A voltage signal proportional to the deflection is produced when the light beam is off center.

Three coils of wire concentric with the chamber are also shown in Figure 2. Currents passing through these coils create magnetic fields which interact with the magnet on the bridge to exert small, controllable, and measurable forces on the bridge. The center coil is energized to dampen oscillations of the balance. The other two coils, the torque or nulling coils, carry a dc current to maintain a constant force as required to balance the bridge.

The output from the photocells, inputs to the coils, and readout information are handled by two, or optionally more, electronic units. The basic two are the Auto-Null unit, manufactured by Worden Quartz Products, and a slightly modified John Fluke nulling digital voltmeter (DVM). The Auto-Null (see block circuit diagram, Appendix A) interprets the signal from the photocells and supplies in response a fluctuating current to the damping coils and a steady dc current to the torque coils. A servo, controlled by the voltage signal from the photocells, drives a ten-turn potentiometer to adjust the torque current to the exact amount required to null the output from the photocells. This process is called "nulling the balance".

The signal sent to the nulling coils is also reported to the electrical output terminals on the Auto-Null as the voltage developed across a 5K-ohm resistor. The DVM (called the Readout Instrument in Worden literature) is connected to these terminals. Thus, the voltage it measures is directly proportional to the current in the torque coils and hence to the electromagnetic "lift" required to null the balance. After calibration, the appropriate constant multiplied by the change in voltage gives the weight, or change in weight, of the mass being weighed.

Outside the chamber is another small permanent magnet mounted horizontally in a worm gear driven shaft. As this magnet is rotated (by means of a knob near the top of the instrument) an adjustable force bias is put on the internal magnet. This allows rough balancing of the microbalance.

The cylindrical chamber containing the balance is sealed except for a full diameter opening at the bottom. This opening is fitted to a ground glass joint. A lower chamber, suitable to the needs of the user, can be equipped with a mating joint to provide a vacuum tight enclosure in which to operate the balance.

## B. MODIFICATIONS FOR USE AS A GRADIOMETER

The most fundamental "modification" is the alteration of the microbalance in such a way that it responds to changes in the local gravity gradient. Two equal masses placed in different positions in a gravity gradient field will have different apparent weights. Further, as the gravity gradient changes the apparent weight difference will change. To make the microbalance responsive to these forces, two 10 gram weights are suspended from the microbalance with a vertical separation of about 1 meter. Changes in the gravity gradient then cause changes in the null-point of the microbalance.

The earth has a "normal" gravity gradient of 3086 Eötvös Units (0.3086 milligals/meter or  $0.3086 \times 10^{-3}$  cm/sec<sup>2</sup> per meter). The deviations or anomalies from this "normal" value due to geologic features are on the order of tens or hundreds of Eötvös Units. To detect a change in gradient of 1 Eötvös Unit, assuming 10 gram masses with 1 meter separation, requires a balance with a force resolution of  $10^{-6}$  dynes. In more familiar terms, this is equivalent to a mass resolution of 1 milli-microgram (out of 10 grams) at earth "g".

The standard Worden Microbalance available prior to the start of this investigation had a specified resolution of 100 milli-micrograms. In order to make a useful gradiometer, the electronics were improved to reduce the nulling range by about 40 times to 5 milligrams which most importantly increased the resolution by 40 times to a nominal value of 2.5 milli-micrograms. This feature is now incorporated into all Worden microbalances.

Given the concept and an instrument theoretically capable of making the measurement, there remains a considerable gap to operational success. A large amount of effort was required to evolve an operating doctrine, shield the instrument from outside influences and generally smooth out difficulties. This work has



been accomplished and the instrument is now functional as a gradiometer. That this was possible is largely due to proprietary knowledge and prior research of Dr. Lloyd G. D. Thompson. Above and beyond the original stock microbalance, it was necessary to provide extra shielding of the electromagnetic components to suppress outside magnetic interference. The internal 10 gram masses were cast of lead to avoid magnetic attraction problems. All exposed glass parts were wrapped in aluminum foil to bleed off static electricity charges. A long pyrex lower chamber was fabricated to enclose the weights. A larger than normal tripod was necessary to hold the instrument at a suitable elevation. A vacuum pump and mercury manometer completed the vacuum system.

A variety of readout techniques was tried, including direct reading of the output of the photocells, A storage oscilloscope and a different digital voltmeter were also used at various times to sample the microbalance output. A most useful readout system was a strip chart recorder. The Fluke DVM provides an output of about  $\pm 0.5$  volts proportional to the deflection of its panel meter. This signal can be recorded on the strip chart to give a graph of nulling force versus time.

With the instrument so modified, successful gradient measurements over proof masses were made. The prototype unit used in this investigation appeared to be capable of measurement resolution of at least 10 Eötvös Units.

### C. SETUP AND OPERATING PROCEDURE

Figure 2 shows the microbalance element with the Mu-metal shielding removed. The coils which create the electromagnetic field can be seen. The optical components are mounted on the top plate. Figure 3 shows the tripod, the microbalance with the Mu-metal shielding in place, the lower glass tube which encloses the



Figure 3. Microbalance with Mu-metal shielding and long tube vacuum enclosure.

weights and the two cables which run from the instrument to the Auto-Null control unit. Figure 4 shows the addition of the vacuum pump, aluminum foil electrostatic shielding and, incidently, higher blocks under the tripod legs to permit moving the proof mass under the instrument. Figure 5 shows the completely assembled basic microbalance including the Fluke DVM (the left hand instrument) and the Auto-Null unit.

The instrument should be set up in a quiet location free from physical shocks or vibration, preferably on an isolated pier. The floor, if any, should be strong, as inflexible as possible, and well supported from below. The tripod legs should be placed on substantial blocks which will not yield with time. A table for the electronic units and convenient electric power must be provided. Since temperature changes can cause drift, the area should have good temperature regulation.

After a suitable site is selected, assemble the tripod and mount the instrument head. Align the head on the tripod so that the tilt plane of the bridge arm is parallel to the plane of the two foot screws. Initially level the tripod using a spirit level on the top plate. If necessary, put spacer blocks under one or more legs so the footscrews will be near the middle of their range of adjustment. Connect the electronic units, turn them on, and allow several hours for warmup. Some weight should be kept on the center hook (sensitivity hook) at all times to keep the suspension fibers taut. Five grams is the maximum capacity for the sensitivity hook while at least 200 milligrams is necessary to do any good.

A precise side-to-side leveling is now in order. The purpose is to adjust the frame, and hence to recover the manufacturer's original level position by means of the tripod footscrews. The photocells will report a null voltage when the balance bridge is

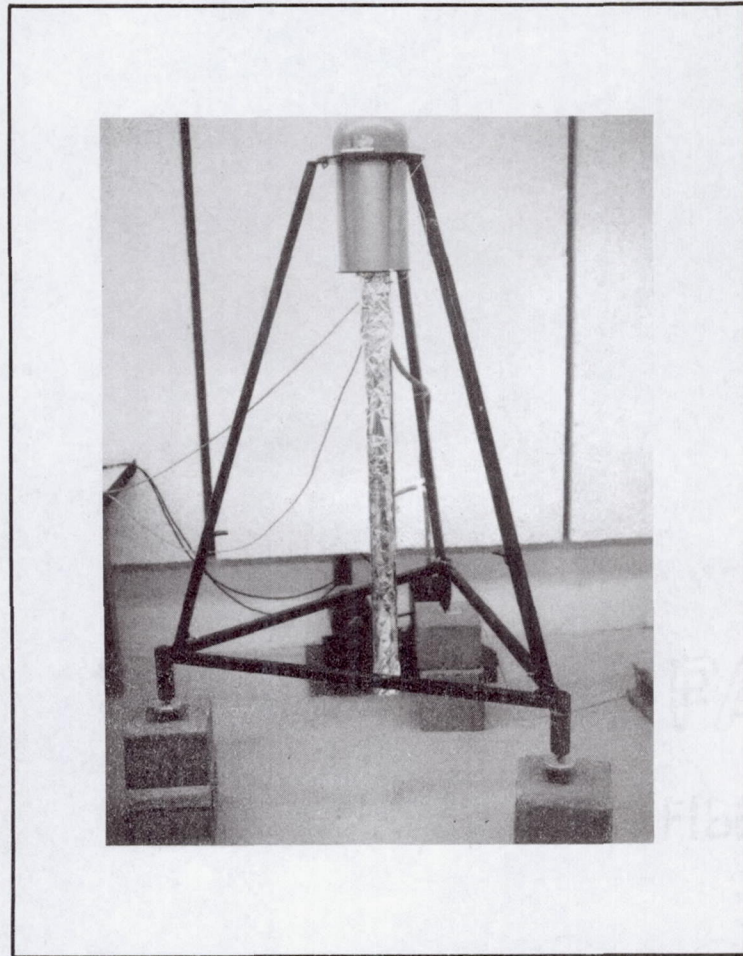

Figure 4. Microbalance with electrostatic and magnetic shielding together with vacuum system.

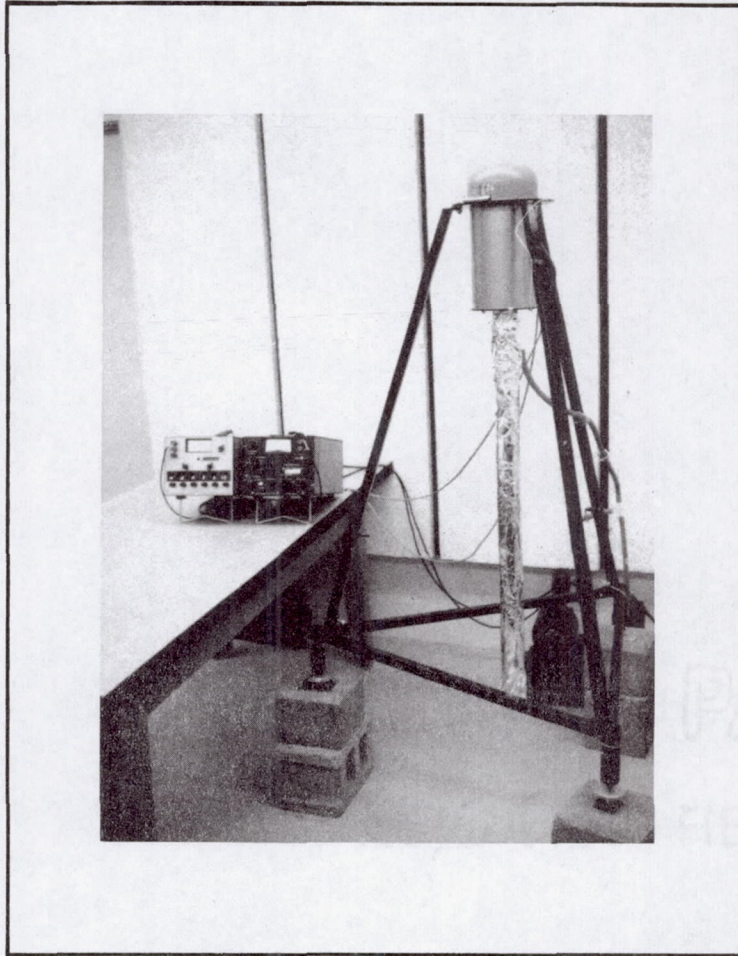

Figure 5. Complete microbalance with Fluke digital voltmeter readout and Auto-Null control unit.

precisely level (providing that the external magnet is not disturbed from its original condition). Disconnect the cable which supplies power to the damping and nulling coils. Put a 5 gram weight on the sensitivity hook with the side hooks empty. This comparatively heavy weight will cause the balance to be aligned in the local vertical and the bridge arm will be in a horizontal or level position. The panel meter on the Auto-Null unit reports the signal from the photocells, and thus the apparent tilt of the bridge. The footscrews are turned always as a pair in opposite directions to preserve fore-and-aft leveling, until the meter is nulled. Zero output from the photocells will then correspond to the level position of the bridge.

Proceed with the final assembly of the instrument in gradiometer configuration. Put the Auto-Null in manual mode, then adjust the MANUAL NULL control until the DVM reads zero volts. Reconnect the cable to the coils. Put a mass of about 200 milligrams on the sensitivity hook and one 10 gram weight on the tare hook, the hook on the right. Then hang the other 10 gram weight on a long quartz fiber on the sample side. Depending on the exact geometry of the location and tripod it may be necessary to lower the long fiber with the 10 gram weight into the bottom tube and move both into position below the bridge before hooking the fiber onto the sample hook. For the prototype unit it was found necessary to reverse the weights (put the fiber on the tare side) to prevent the lower weight from rubbing the inside wall of the tube. This is an unimportant change affecting only the sign of the readout.

Two adjustments must be made before sealing the system. The period of free swing must be adjusted to 5 to 7 seconds in air and the side masses must be adjusted within 2 milligrams of null balance. The Auto-Null panel meter indicates the heavier side of the balance by deflecting in that direction from null.

Using this as an indicator, add trim weights to the lighter side until the two sides are within 2 milligrams of a side-to-side balance. When this is achieved, turn the Auto-Null to SERVO. The servo will automatically adjust the nulling current to the value required to lift the balance bridge to a level position. The Fluke DVM will read a voltage proportional to the lift. Manually adjust the external magnetic biasing (by the knob on the top of the balance) to decrease the required amount of electromagnetic lift. Try to reduce the reading on the DVM to within  $\pm 0.5$  millivolt of zero voltage. Turn the Auto-Null to MANUAL or STANDBY and disconnect the cable to the coils. The balance will then oscillate freely at its natural period. This period, in air, should be about 5-7 seconds. If it is too short, remove some weight from the sensitivity hook. If too long, increase the weight slightly. If the balance slowly falls to one side or the other, it is unstable and requires a larger sensitivity weight. Small sensitivity weight changes produce large changes in stability or period of the balance. A satisfactory way to adjust the weight is to use a fine wire as part of the weight, then trim or file it to approach the proper period. The period will become somewhat longer when the chamber is evacuated due to the loss of atmospheric buoyancy on the various components.

Mount the lower tube, using plenty of vacuum grease on the O-ring and ground glass joint to prevent sticking and difficult removal. Attach the vacuum pump and evacuate the chamber. The unit should then be functional as a gradiometer, as shown in Figure 5.

Gravity gradient measurements are made by putting the Auto-Null into SERVO mode and observing the voltage change on the Fluke DVM or a strip chart recorder connected to the DVM. The absolute value of the voltage is not significant, but as proof

masses are placed under the gradiometer or as the gradiometer is moved to a region with a different gradient, the voltage reading should change. The prototype unit is configured in such a way that an increase in voltage indicates that the sample side is heavier. If the lower mass is on the tare side, as it is in the prototype, then a decrease in voltage indicates a greater "pull" on the lower mass (relative to the upper mass) corresponding to an increase in the gravity gradient.

#### D. LABORATORY TEST SET-UP

The microbalance was first assembled as described in Section C. above and put into operation in the General Oceanology laboratory as shown in Figure 5. For actual gravity gradient measurements, additional equipment was required. Figure 6 shows the microbalance and other equipment as it was used for the final and most successful series of measurements. Included in this picture are a strip chart recorder, lead proof mass and its transport device, and a gravity meter. Figure 7 shows all of the instrumentation and equipment used throughout the laboratory tests including a storage oscilloscope and a second digital voltmeter which were used to measure different output signals of the microbalance.



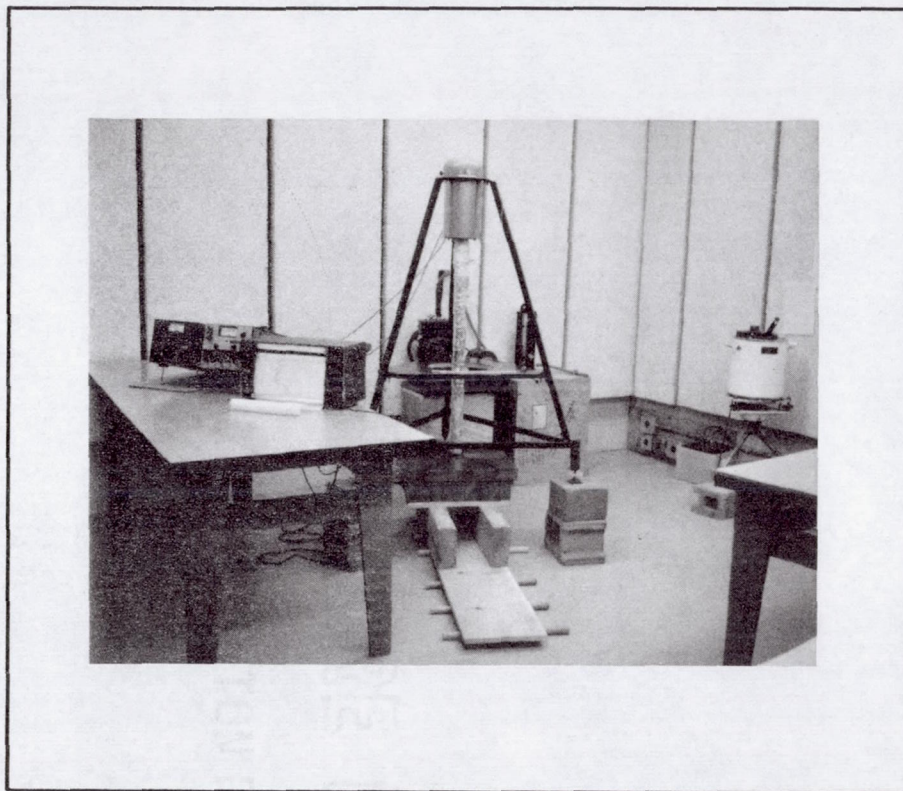

Figure 6. Auto-Null Microbalance system as used for final gradient measurements showing millivolt recorder, lead proof mass, and gravity meter.

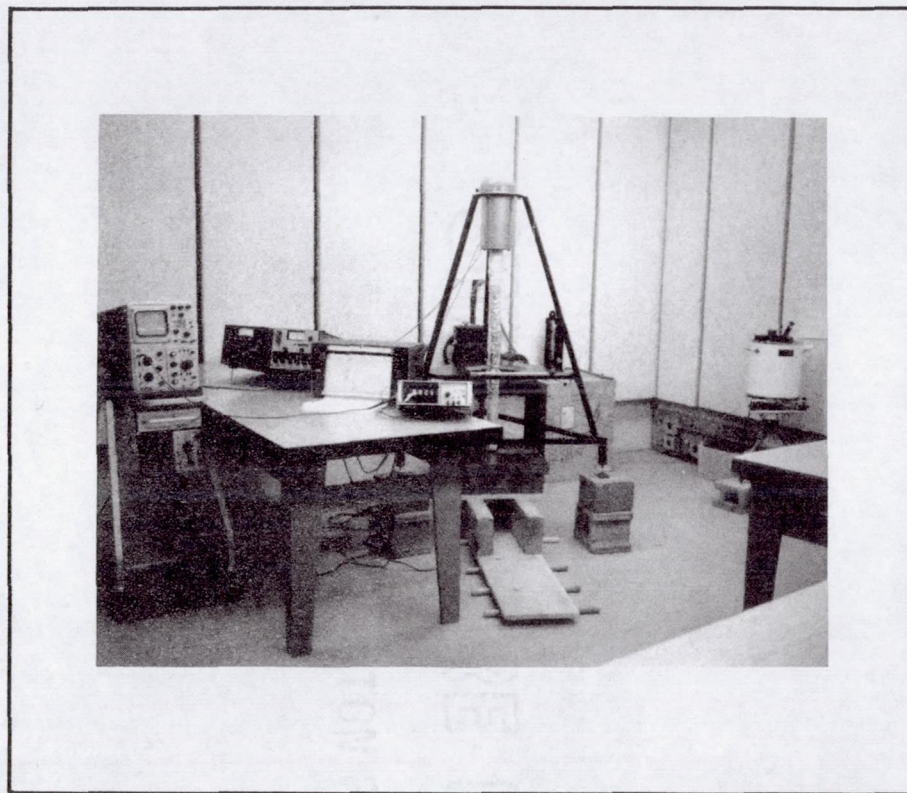

Figure 7. Microbalance system as used during laboratory tests showing various recording systems: millivolt recorder digital voltmeter, and storage oscilloscope.

### III. ANALYSIS OF MICROBALANCE GRADIOMETER OPERATION USING PROOF MASSES

The instrument measures "average" vertical gravity gradients over proof masses in the laboratory exactly as it measures "average" vertical gravity gradients over geologic structures in the field. However, the interpretation of these two measurements is somewhat different.

Figures 8a and 8b illustrate the relative scale of the instrument size to a geologic structure and a proof mass respectively. In the field over geologic structures, the gradient remains constant over a vertical distance comparable to the instrument's height: the gradiometer measures the gradient at the mid-point between the two masses. In the laboratory a proof mass is small compared to the instrument's sensor-mass separation. The vertical gradient changes significantly over the instrument's height as shown in Figure 9: in this case the gradient at the mid-point is not equal to the average gradient. This figure shows the vertical gradient ( $\partial\Delta g/\partial z$ ) of a constant density sphere versus the normalized distance from the center of the sphere. The gradient decays very rapidly with distance from the surface of the sphere and is nearly zero at three times the radius.

Thus, over a small proof mass, the microbalance really acts like a gravity meter. The gravity anomaly at the lower weight times the mass of the lower weight is essentially the unbalancing force. The gravity anomaly at the top mass is small compared to the anomaly at the bottom mass and can usually be neglected. The "equivalent" gradient measured by the gradiometer is the gravity anomaly difference between the two masses divided by their vertical separation.

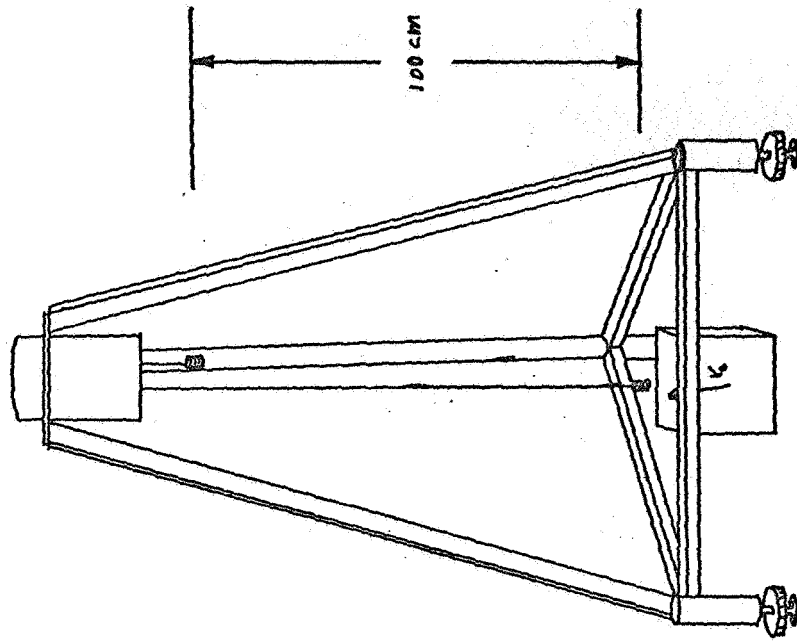

a)

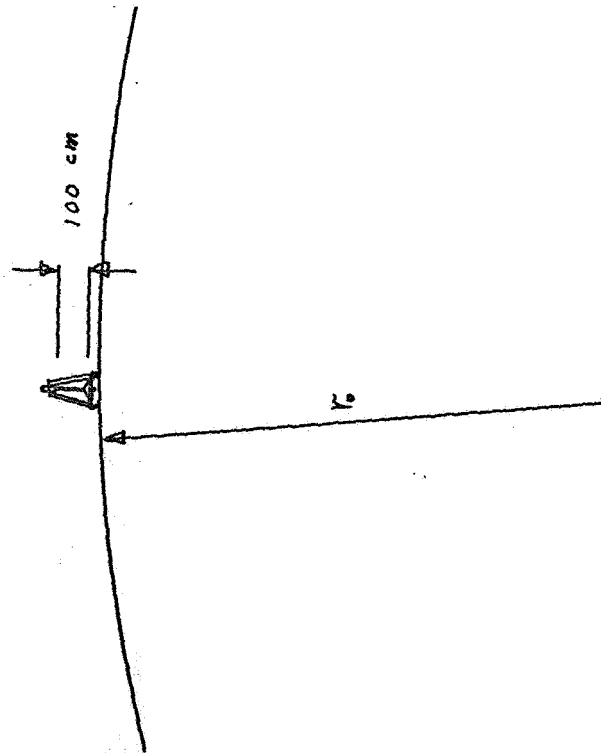

b)

Figure 8. Relative Scale of Gradiometer Size to a Geologic Structure and a Proof Mass

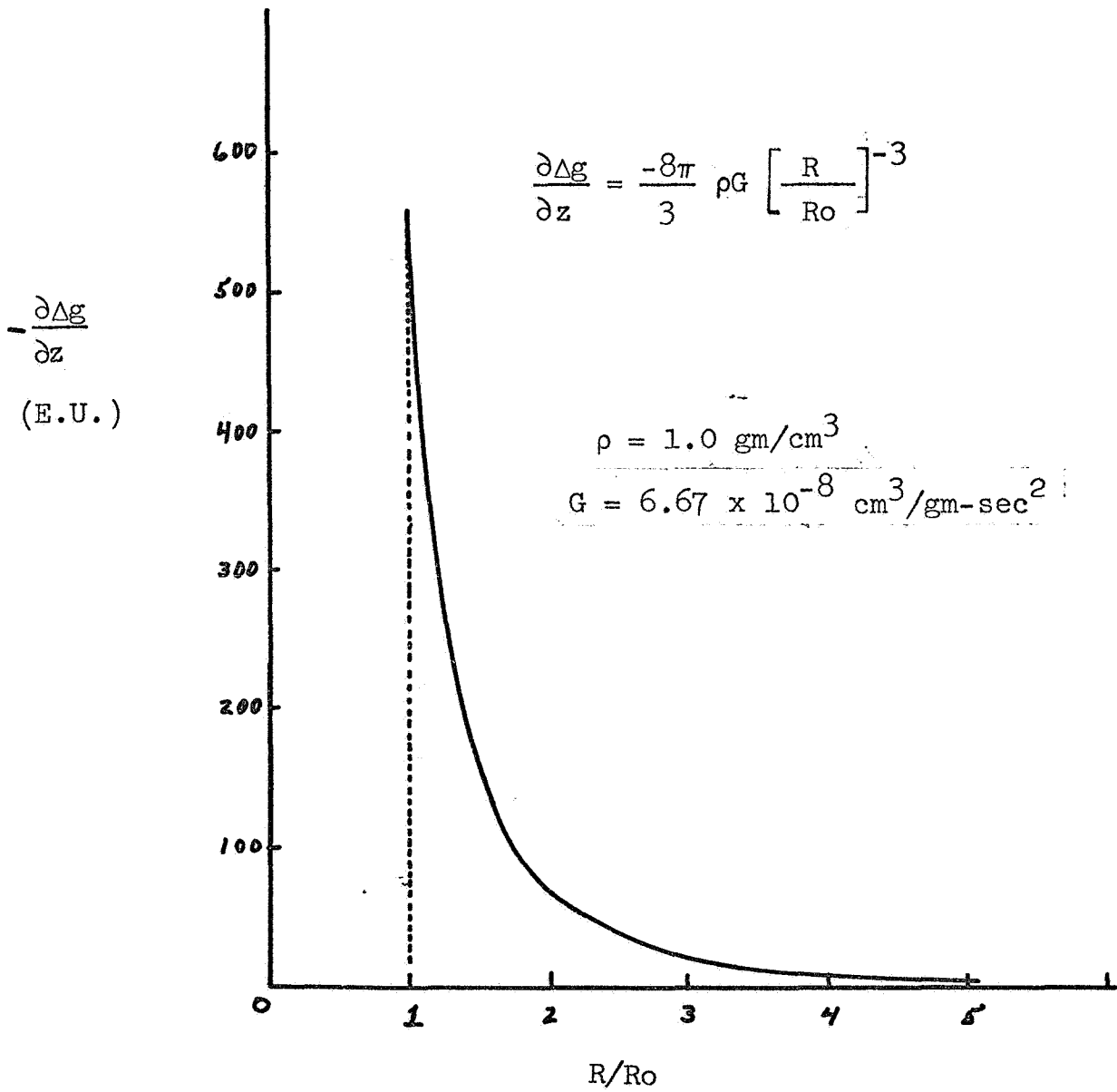

Figure 9. Vertical Gravity Gradient as a Function of Distance from a Sphere

This "equivalent" gradient is the weighted average of the vertical gravity gradient of the proof mass over the separation interval. As seen by Figure 9, this is the value of the proof mass gradient at a short distance above the lower mass and not at the mid-point between the masses. The equivalency of the gradients is shown by the following equations:

$$\overline{\frac{\partial \Delta g}{\partial z}} = \frac{\int_{R_1}^{R_2} \frac{\partial \Delta g}{\partial z} dz}{\int_{R_1}^{R_2} dz}$$

$$\overline{\frac{\partial \Delta g}{\partial z}} = \frac{(\Delta g|_{R_2} - \Delta g|_{R_1})}{R_2 - R_1}$$

Therefore, the microbalance gradiometer measures a true "average" gradient in both the laboratory and the field, but it doesn't make sense to talk about an "average" gradient over a small proof mass.

Laboratory proof masses may be used very effectively to calibrate the microbalance gradiometer with a high order of accuracy. Calibration of the instrument is achieved by using proof masses whose gravity anomaly can be easily calculated. The shape of the proof mass doesn't much matter since the instrument is most sensitive to the gravity anomaly of a small body and not its gradient.

As an illustration of the above points, Table 1 lists examples of the gravity anomaly and the gravity gradient at the surface of both a laboratory proof mass and a geologic mass. The vertical derivative of the gravity gradient has also been included to show how the gradient changes with height for different sized masses. The equivalent gradient for the proof mass in Table 1 for a 100 cm mass separation would be 470 E.U. as follows:

TABLE 1  
 COMPARISON OF THE GRAVITY ANOMALY, VERTICAL GRADIENT,  
 AND GRADIENT CURVATURE BETWEEN A GEOLOGIC-SIZED MASS AND A LABORATORY PROOF MASS

	Case I	Case II
Vertical Gravity Anomaly	15 cm radius lead sphere $\rho = 11.3 \text{ gm/cm}^3$	1 km radius sphere with density contrast $\rho = 1.0 \text{ gm/cm}^3$
	$\Delta g = \frac{GMZ}{R^3}$	$47 \times 10^{-6} \text{ gals}$
Vertical Gravity Gradient	$\frac{\partial \Delta g}{\partial z} = \frac{GM}{R^3} \left[ 1 - 3 \frac{z^2}{R^2} \right]$	- 558 E.U.
Vertical Gravity Curvature	$\frac{\partial^2 \Delta g}{\partial z^2} = \frac{36MZ}{R^5} \cdot \left[ \frac{5z^2}{R^2} - 3 \right]$	1260 E.U./cm
		0.016 E.U./cm

$$\frac{\Delta g}{d} = \frac{-47 \times 10^{-6} \text{ gals}}{100 \text{ cm}}$$

$$\frac{\Delta g}{d} = -470 \text{ E.U.}$$

Note the effectiveness with which a small proof mass may be used to simulate a large geologic structure such as a 1 km radius sphere. The lead proof mass near its surface has a very large vertical gravity gradient (6300 E.U.) which changes rapidly with vertical distance (1200 E.U./cm). At a distance of 100 cm or about 7 radii above the surface of the mass (Figure 9) the gradient is negligible; however, the average gradient is the equivalent gradient calculated from the vertical gravity anomaly or 470 E.U. Demonstration of the ability of the instrument to measure equivalent gradients over proof masses in the laboratory establishes the capability of the instrument to measure desired vertical gradients over geologic structures in the field.



#### IV. EXPERIMENTAL PROCEDURES

Much of the experimental work involved investigating disturbing effects and establishing proper operating procedures to be sure that only gravitational effects were measured by the microbalance. The system output which indicates a gravity gradient change is a voltage change. However, and not completely unexpectedly, there are also other environmental influences which can cause a change in output voltage. Much of the work effort was directed toward isolating and removing, if possible, these outside influences. A variety of things were learned and appropriate changes made. Initial tests were made with the internal gradiometer masses at the same elevation (with the weights level, vertical gravity gradient changes should cause no changes in output reading) to check the normal function of the balance, determine the extent of outside influences, and generally become familiar with this particular equipment. Extensive gradient data were then taken with the balance in gradiometer configuration. A final test was made with the weights at the same level to confirm that gravity gradients had indeed been observed.

Discussions of some of the disturbing effects and efforts to deal with them follow:

##### 1. Tilt Effects

The unit operates by measuring the extra force exerted by the electromagnetic system required to hold the balance beam at a certain position, nominally level, such that the photocell output is nulled. The balance beam is acted on by many torques and forces which arise in several ways. If the position of the photocells change, as by a change in the tripod frame to which they are attached, then a different electromagnetic torque will be required. This will cause a change in output voltage which could be confused with a gravity gradient change. Therefore, at least two anti-tilt precautions are indicated. The tripod should be physically sturdy and the foot pads must not rest on a surface subject to tilt.

The first condition, a sturdy tripod, was marginally met with the tripod supplied by the manufacturer.

For this preliminary investigation, the problem of floor tilt could only be tested and held to a minimum by experimental procedures. From the configuration of the balance bridge suspension (two fibers supporting the shaft which forms the axis of rotation) it is clear that tilt parallel to the rotational axis is much less serious than tilt perpendicular to that axis. It was found in early testing that the weight of a man shifted from leg to leg of the tripod perpendicular to the rotational axis would cause a tilt which was reported as a voltage change on the order of half as large as the eventual change caused by the genuine gradient of the proof masses. However, changes in a man's position along the rotational axis seemed to cause changes no larger than those of the background noise. The original plan was to use proof masses on the order of 25-50 kilograms moved along the axis so that no tilt problems were anticipated. However, the proof masses eventually used were nearly 300 kilograms. They were sufficiently heavy to introduce a small tilt error when moved along the axis. To check this, the final tests were performed with the gradiometer masses at the same level. It was found that the instrument readings were being contaminated by a slight tilt effect. The readings were corrected for this effect.

In reviewing the data, it appeared that the tilt or yielding of the floor was not strictly predictable or constant with time. On some occasions, insertion or removal of the proof mass caused little or no tilt effect while at other times (most times) there was a significant change. Partly, the amount of change depended on how far the mass was withdrawn from the tripod, that is, as the relative positions of the mass, tripod, and floor supports changed. Beyond that, however, the floor did not necessarily yield immediately with time. Changes were often not uniform but rather proceeded in steps or sudden jumps.

## 2. Local Ground Disturbances

Related to tilt, in the sense that it is a physical change in position transmitted by the floor, is the problem of vibration. It was easily demonstrated that a jolt to the floor, such as a heavy footfall, would cause a transient deflection in this extremely sensitive unit. Similarly, street traffic or persons walking and working in the building caused a background of less dramatic but more serious disturbances.

To minimize this noise in the data, it was necessary to make measurements early in the morning when environmental conditions were quiet. The hours between 0200 and 0500 were most satisfactory. At these times, the vibrational noise was a minimum and the signal (gravity gradient change) was more distinct.

## 3. The Internal Weights

The original internal 10 gram masses were "non-magnetic" class S brass laboratory balance weights. It was discovered, however, that they had sufficient residual magnetism to deflect a compass needle. Because the balance functions with electromagnetic forces and these weights introduced the possibilities of magnetic effects from ferrous objects outside the balance and from the earth's magnetic field, they were not acceptable. Early tests confirmed this. New weights of  $9.5585 \pm 0.0002$  gms were cast using tin-lead solder as a material. These have been used successfully together with lead proof masses.

## 4. The Proof Masses

Original plans were to use proof masses of iron or brass. However, due to cost, availability of material, ease of handling, and primarily magnetic effects, it became apparent that the most satisfactory material would be lead. Consequently, forty 2"x4"x8" lead bricks weighing 26 pounds each were acquired. These were configured into two proof masses: a 12" cube and an 18"x18"x6" slab. To facilitate ease of handling, the models were constructed on a wooden platform supported with wooden rollers (See Figures 6 and 7). It was a simple matter to roll the lead masses under and away from the gradiometer.

## 5. Electrostatic Charges

The glass and quartz components used in the construction of the gradiometer tended to acquire and hold electrostatic charges. Rapid movement of persons or objects across the tile floor near the unit was enough to cause the build-up of an electrostatic charge. Wool suit coats and silk ties also could induce gross charges, with resulting forces acting on the system. A reasonably effective solution was to enclose all exposed glass parts with aluminum foil grounded to the tripod frames.

## 6. Magnetic Disturbances

The balance bridge and its electromagnetic nulling components were enclosed in a double Mu-metal shield. The proof masses and internal gradiometer weights were carefully chosen to be non-magnetic. However, there continued to be problems with magnetic interference. Probably this was due to outside influence on the magnet on the balance bridge, in spite of the shielding. The most dramatic demonstration of this problem was initiated by the movement and rotation of an iron laboratory stool (which was found to have a high residual magnetism) from ranges in excess of three meters. This produced large, immediate effects on the microbalance output. These changes were several times larger than the gradient effects of the proof masses. To avoid data contamination from this cause, care was used during measurements to avoid bringing iron objects near the instrument. More generally, no objects likely to cause any disturbance were moved during the tests.

## 7. Temperature Effects

On several occasions during measurements or when overnight records were taken, long-term drifts were apparent. These seemed to be correlated with temperature changes during those times. Worden lists a temperature coefficient of 1 microgram per degree centigrade for the original, unmodified instrument. A large temperature effect was therefore anticipated for the higher sensitivity of the modified instrument. However, due to the vacuum system, general enclosure of the instrument, and generally

steady room temperature in the laboratory during measurements, this was not a serious problem. When there was drift, it was reasonably slow and steady and as such could be distinguished from gravity gradient changes in the record.

#### 8. Pressure (Vacuum) Effects

Quartz structures like the microbalance function much more sensitively in a vacuum than at atmospheric pressure. There are two pressure regions that give good results, one between 0.1-3 Torr (1 Torr = 1 millimeter mercury) and the other the high vacuum region below  $10^{-5}$  or  $10^{-6}$  Torr (Robens, 1969). The intermediate vacuum range is unsatisfactory as thermal currents of the residual gas in the chamber cause physical disturbance to the balance. The prototype was operated in the first pressure range, as determined by a mercury manometer, because (1) previous experience of Dr. Lloyd G. D. Thompson had shown that, with care, the balance could be operated satisfactorily at this pressure, and (2) for these tests the instrument could not readily be connected to a high vacuum pumping system. Tests were made throughout the pressure range of 0.1 to 3 Torr with no discernable dependence of the results on pressure.

#### 9. Line Voltage Fluctuations

On several occasions large excursions were observed on the strip chart which had no apparent correlation to physical shocks or other obvious cause. It was concluded from various evidence, including the behavior of other electronic equipment in the laboratory, that the problem was bursts of energy or sharp voltage transients coming over the power line. The problem was particularly severe during one data recording session.

#### 10. Gravity Tide Effects

A gravity meter was operated near the gradiometer during measurement periods to determine if gravity tides had any effect on the gradiometer readings. Observation periods were short (a few hours) and there was no apparent correlation of the records over this time span.

## V. RESULTS

### A. GRADIENT MEASUREMENTS

#### 1. Initial Tests

An important part of this investigation was the development of an instrument configuration and measurement procedures which left no doubt as to the fact that the instrument was sensing and measuring gravitational effects distinct from other effects. The first conclusive demonstration of this capability was possible only after the isolation of disturbing effects and after the introduction of lead weights both in the microbalance and as proof masses. In a series of preliminary measurements, the instrument definitely and repeatedly responded to gradient changes (measured by the Fluke DVM as a voltage change in microvolts) over the lead proof mass configured as a vertical cylinder. These results were referenced in the Mid-term Report (Thompson, 1969). With more carefully controlled conditions and procedures, another series of preliminary measurements were made over a 12" x 12" x 12" lead cube. In this case, an amplified output signal in millivolts was measured on a second DVM and the long term variations in the output were monitored on a storage oscilloscope. These encouraging results (which gave the same results as later tests) prompted a new series of tests and measurements. Still further improvements in procedures were made and an output signal compatible with a millivolt strip chart recorder was selected.

#### 2. Final Measurements over Proof Masses

A final series of tests and measurements were made in late June and early July with the microbalance gradiometer in its optimum configuration as shown in Figure 6. The output signal was recorded on a strip chart recorder for maximum resolution (sensitivity) and the microbalance was operated in its normal SERVO mode for automatic force-balance nulling. Measurements were made during early morning hours between 2 and 5 o'clock when ambient vibrations and electrical noise were at a minimum. These are believed to be the most accurate and most reliable measurements

obtained in this investigation and are, therefore, the only results presented in this report. They illustrate the measuring capability of the microbalance in its present form.

The final tests were performed using two lead proof masses: a 12" x 12" x 12" cube and an 18" x 18" x 6" slab. Repeated measurements were made both during the same observation period and on different days with the proof masses in three positions as follows:

a) The center of the proof mass directly under the lower weight of the microbalance. (This was taken as the reference position).

b) The edge of the proof mass directly under the lower weight of the microbalance.

c) The proof mass completely removed.

Figure 10 is a portion of the strip chart record obtained on June 26. This shows the distinct response of the microbalance (as a voltage change in millivolts) to the gravitational effect of the lead cube proof mass. It also shows the electronic and ambient vibration noise in the output signal under good environmental conditions. Figure 11 is a portion of a similar record obtained on July 2 which shows the repeatability of the instrument response to the presence of the cubic proof mass. A summary of the results of all such measurements made during the final test series is presented in Table 2. The measurement of interest is the instrument output which is given as the voltage change ( $\Delta V$ ) in millivolts from that when the proof mass is directly under the microbalance to that when the mass is moved to the side or completely removed. This procedure was adopted to minimize floor tilt in the edge measurements and to be compatible with measuring changes from the peak anomaly over the proof mass. The measurements are corrected for tilt effect. The results of a final tilt calibration test for a lead slab proof mass are also given in Table 2. In view of the

26 June 1969

0450 (EDT)

0500

100

80

60

40

20

0

Relative Output (mV)

$\Delta V = 60 \text{ mV}$

PROOF MASS AWAY FROM BALANCE

PROOF MASS UNDER BALANCE

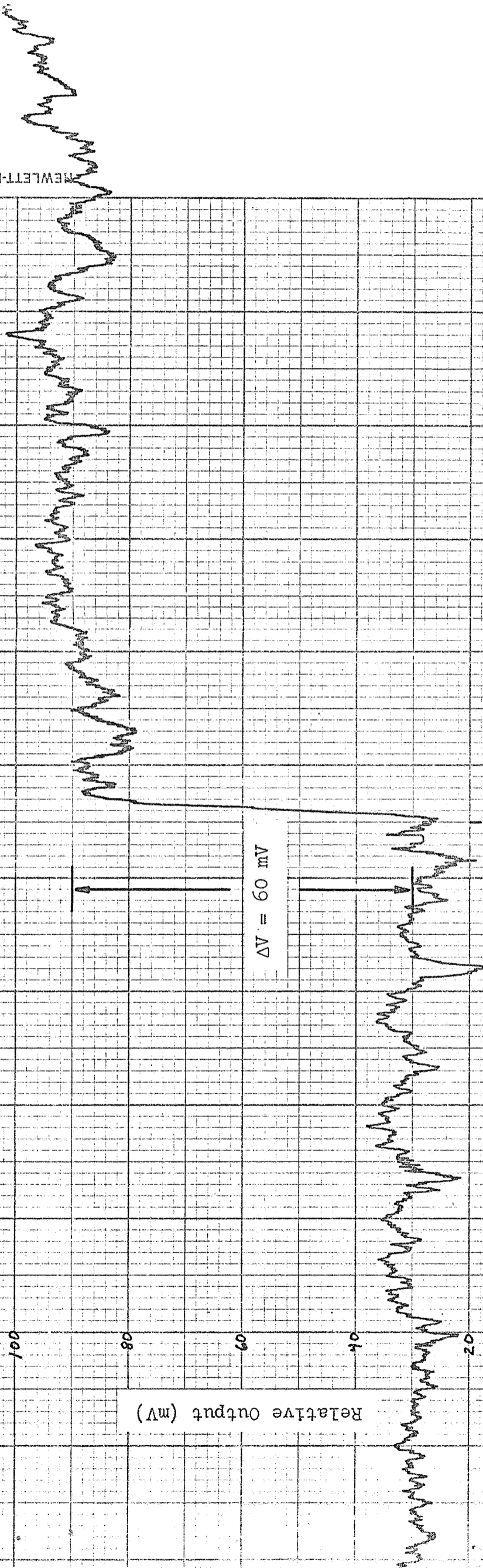

HEWLETT-PACKARD/MOSELEY  
9270-1053

Figure 10. Strip-Chart Recording of Instrument Response for Cubic Proof Mass Under Normal Observing Conditions



2 July 1969

0330 (EDT)

0340

0350

Relative Output (mV)

100

80

60

40

20

0

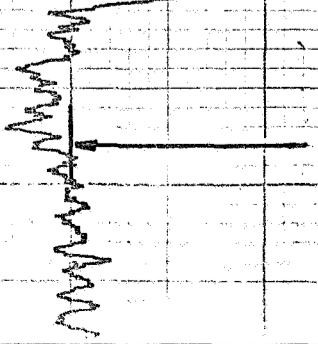

PROOF MASS UNDER BALANCE

$\Delta V = 54 \text{ mV}$

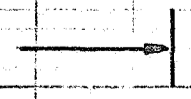

PROOF MASS AWAY FROM BALANCE

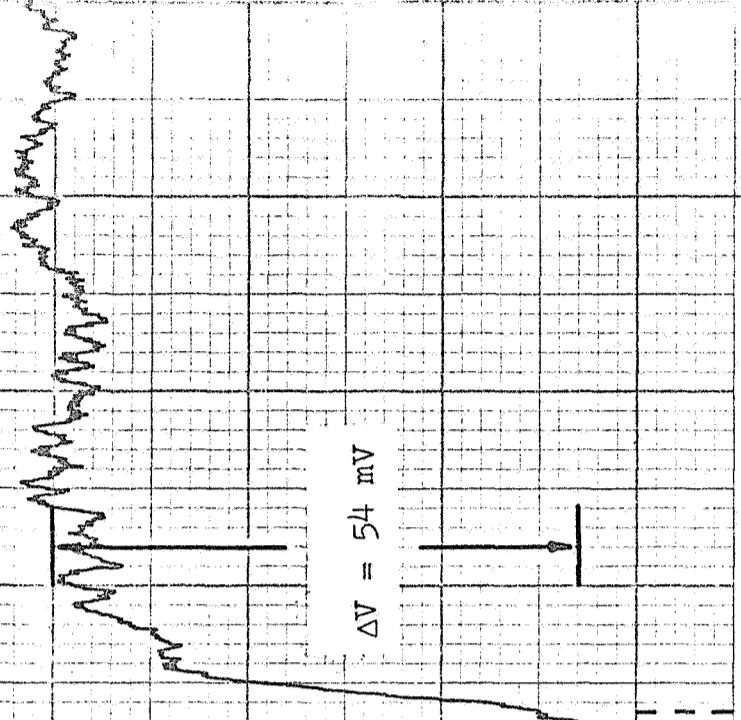

PROOF MASS UNDER BALANCE

$\Delta V = 54 \text{ mV}$

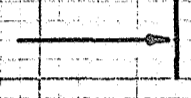

Figure 11. Strip-Chart Recording of Measurements Over a Cubic Proof Mass Illustrating Repeatability of Microbalance Response

TABLE 2 - SUMMARY OF PRELIMINARY GRADIENT MEASUREMENTS

<u>Date</u>	<u>Proof Mass Position Change</u>	<u>No. of Trials</u>	<u>Average Instrument Output (mV)*</u>	<u>RMS Error (mV)</u>
<u>CUBE</u>				
6/26	center to out	3	49	1.6
6/27	center to out	5	57	11.0
6/27	center to edge	5	30	6.5
7/1	center to out	7	57	7.3
7/2	center to out	5	47	6.3
7/2	center to edge	6	21	8.8
TOTAL	center to out	20	53	8.9
	center to edge	11	25	8.5
<u>SLAB</u>				
7/3	center to out	5	61	7.8
7/3	center to edge	4	42	6.6
<u>TILT CALIBRATION</u> /				
7/8	center to out /	6	11	5.4
7/8	center to edge	1	0	-

---

\* Corrected for floor tilt

/ Both masses suspended at same height on short fibers

/ Includes one "edge to out"

disturbing effects discussed earlier under Section IV on Experimental Procedures, the variations in the measured output voltages are not unexpectedly or unduly large. The only discrepancy appears to be in the measurement over the edge of the slab where the value seems particularly low. This may reflect an occasion when floor tilt did not occur as anticipated but, in general, edge measurements are not as reliable because a slight variation in proof mass position causes a large change in the gravity effect.

It has previously been explained (Section III) that the microbalance gradiometer does not measure gradients over proof masses in the laboratory the same as it measures gradients over large geologic structures in the field. It is not appropriate to speak of a gradient profile over a proof mass because it is not obtainable per se in the laboratory with a microbalance type gradiometer. What the microbalance actually sees and measures is an "average" gradient determined by the difference in the gravitational attraction ( $\Delta g$ ) of the proof mass acting on the two weights in the microbalance divided by the distance (vertical separation) between these weights. This is illustrated in Figure 12 which shows gravity anomaly profiles and "equivalent" vertical gradient profiles over a lead cube and a lead slab for the instrumentation configuration used in these tests. The gravity anomaly profiles are for a height of 1.27 centimeters above the surface of the proof mass (the distance to the center of mass of the lower gradiometer weight) and have been calculated by the method of Grant and West (1965), pp. 225-227. The "equivalent" gradient profiles are derived by taking the gravity anomaly (less a small amount for the effect on the upper microbalance weight) and dividing by the distance between the gradiometer weights, in this case 92.8 cms. This equivalent gradient profile can be used to calibrate the gradiometer and conversely, once calibrated, the gradiometer will measure this profile. By necessity, the calculated and measured average gradients over a proof mass must be identical.

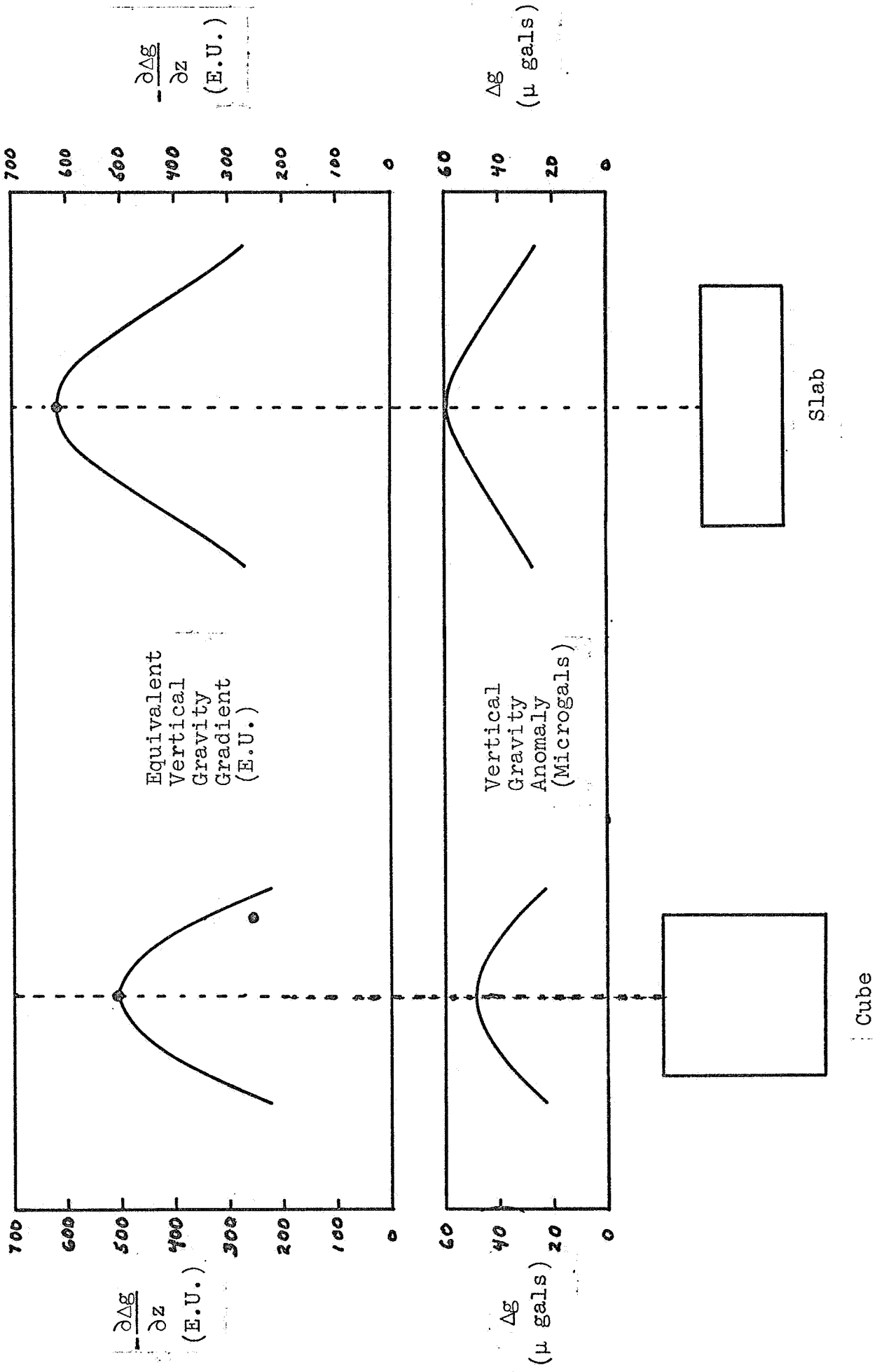

Figure 12. Gravity and Gravity Gradient Profiles over 12" x 12" x 12" Lead Cube and 18" x 18" x 6" Lead Slab Proof Masses

With a little thought, one can see that the measurement of a complete profile over a proof mass is not necessary for calibration purposes or for subsequently determining the profile because a measurement at a single point (say the peak) completely defines the curve. Thus, in these tests there was not much point in making observations at a great number of points on the profile. In fact, the entire instrument test and calibration can be accomplished by simply making repeated measurements with one proof mass in one position (that is, one  $\Delta g$  value). This demonstrates the significant advantage of this type of instrument.

The microbalance can be effectively calibrated by measurements made by placing the lead cube and/or slab directly under the instrument. In the case of the lead cube, the calculated gravity anomalies acting on the two microbalance weights are as follows:

$$\begin{aligned}\Delta g \text{ at lower weight} &= 48.2 \times 10^{-6} \text{ gals} \\ \Delta g \text{ at upper weight} &= 1.8 \times 10^{-6} \text{ gals} \\ \text{Difference} &= 46.4 \times 10^{-6} \text{ gals}\end{aligned}$$

With a vertical separation between the microbalance weights of 92.8 cms this gives:

$$\text{equivalent vertical gradient} = \frac{46.4 \times 10^{-6}}{92.8} = 500 \text{ E.U.}$$

(Note: This is the same calculation for deriving the equivalent gradient curves in Figure 12.)

The average output voltage change measured by the microbalance with the lead cube directly under it is given in Table 2 as 53 millivolts. Therefore:

$$\text{Calibration Factor} = \frac{500}{53} = 9.4 \text{ E.U./mV}$$

Similarly, the calibration factor using the slab is 10.1 E.U./mV. These data are summarized in Table 3. The agreement of the two values is remarkably good so that the mean value of 9.8 E.U./mV appears to be reliable.

TABLE 3 - CALIBRATION OF MICROBALANCE GRADIOMETER

<u>Proof Mass</u>	<u>Calibration Position</u>	<u>Calibration Factor (E.U./mV)</u>
Cube	Center	9.6
Slab	Center	10.1
	AVERAGE	9.8

At these calibration points, the "measured" equivalent gradients necessarily fall exactly on the peaks of the gradient curves in Figure 12. An attempt to illustrate the comparison of a measured equivalent gradient profile and a calculated profile can be made using data for the edges of the lead cube or slab. In the case of the lead cube, the measured output voltage for a change in proof mass position from the center to the edge is given in Table 2 as 25 mV. Using a calibration factor of 9.8 E.U./mV gives a change in the equivalent gradient from the center to the edge of 245 E.U. This point is shown on the gradient profile in Figure 12. The value is lower than the calculated curve and just at the limit of the experimental error. This is significant particularly in view of the more unreliable nature of edge measurements.

The limited average gradient measurements made in these tests are all that are practical or necessary to determine the capability of the microbalance gradiometer to determine "gravity gradient profiles" over simple proof masses. The measurement of equivalent gradient profiles is meaningful only if desired for an irregular proof mass of particular interest. This is a further application of a calibrated gradiometer.

### 3. Discussions

Clarification of the meanings of the terms "sensitivity and accuracy" as referred to herein is in order. Sensitivity of the instrument is considered to be the same as its resolution and is the minimum change in the balance bridge arm position that is detected by the readout system (e.g., a strip chart recorder). The measurement accuracy includes errors from all disturbing sources as well as zero drift and calibration. As an example, the operation of a conventional gravity meter illustrates the meaning of these terms. By means of a visual readout, a gravity change of  $1 \times 10^{-5}$  cm/sec<sup>2</sup> (or an equivalent rotation of the measuring dial) is detectable by the instrument. This is its resolution or sensitivity.

However, under unstable ground conditions, the sensing element moves continually by a small amount and it is difficult to determine the true null position with the visual readout. This introduces an error in the dial reading. In addition, the reading must be corrected for instrument drift and gravity tide effect. A further error arises from the instrument calibration error and perhaps other errors (e.g., pressure, temperature, tares) are present. The summation of all of these errors determines the measurement accuracy. In a series of independent measurements, the accuracy may be indicated by the RMS error.

With due consideration of this particular version of the microbalance and the limiting conditions under which the tests were performed (which are reflected in the RMS errors), the results are remarkably good and show great potential for the device as a gradiometer. The overall accuracy of the measurements is indicated by an RMS error of 9mV (Table 2) which is equivalent to about 90 E.U. by calibration. The resolution (or sensitivity) of the microbalance with a strip chart recorder readout is 1mV or about 10 E.U. This was taken as the least amount (1/2 small chart division for 200mV full scale on the chart) that could meaningfully be attributed to a change in the pen trace under the operating conditions.

Nearly all of the measurement error can readily be attributed to various disturbing effects. The floor tilting effect itself introduces an RMS error of about 5mV (50 E.U.) because the tilt is neither uniform and predictable nor steady with time. Electrical and vibrational noise also contribute a large error. From the chart records shown in Figures 10 and 11, it appears that during quiet times the noise level is about 5mV (50 E.U.) and is much higher at other times. In addition, there is an error of one or two millivolts (10 to 20 E.U.) in determining the mean position of the pen trace. Since these errors can readily be eliminated or minimized by state-of-the-art improvements, it is evident that the



measuring accuracy could be improved to 1 or 2mV (10 or 20 E.U.) and the sensitivity to 0.1 to 1mV (1 to 10 E.U.) under the same operating conditions.

#### B. PERFORMANCE EVALUATION OF GRADIOMETER

The fact that the microbalance could measure the minute forces associated with the gravitational effects of a proof mass, attests highly to its performance capability. The measurements made in these preliminary tests were not of particularly high accuracy in view of disturbing environmental conditions. This should not, however, reflect on the microbalance because the contract funding and work effort was not sufficient to prepare and operate the microbalance under the most favorable and ideal conditions of quietness (which is achieved only under very special circumstances). Further, a main objective was to investigate disturbing effects on the microbalance and to configure it to make gradient measurements in the presence of minor disturbances. This was accomplished and the results were, in fact, surprisingly good and significant improvements can be foreseen.

Under the limiting electronic and environmental conditions in the General Oceanology, Inc. laboratory, the present version of the microbalance has an output resolution or sensitivity of a nominal 10 E.U. Its overall measuring accuracy is about 90 E.U. By eliminating major disturbing effects, an improved version of the microbalance operating under the same limiting environmental conditions should achieve a resolution of 1 to 5 E.U. and a measuring accuracy of 10 to 20 E.U. If this improved instrument were to be used in an ideal quiet isolated environment, a resolution of 1 E.U. or better and an accuracy of 10 E.U. or better should be achievable.

## C. DISTURBING EFFECTS THAT LIMIT SENSITIVITY IN THE LABORATORY

For this preliminary investigation, the microbalance was used in its simplest primitive form for gravity gradient measurements and was, of course, subject to disturbing effects from many sources as discussed in a previous section on Experimental Procedures. Design and engineering improvements will obviously eliminate most, but not all, of the disturbing effects. Effects from temperature, pressure, electrostatics, floor tilt (from proof mass transport system) and external magnetic fields can readily be eliminated and will not be a problem.

The ultimate limitations to the sensitivity of the present gradiometer reside (1) in the nature of the electromagnetic force-balance readout system, and (2) in the presence of seismic and local ground disturbances (accelerations or vibrations).

The force-balance readout system is susceptible to small magnetic field variations and power supply voltage fluctuations which can cause variations in the output signal equivalent to many Eötvös Units. Adequate Mu-metal shielding can remove the effects of external magnetic fields and a high stability power supply can reduce voltage fluctuations. However, small voltage fluctuations and electronic "noise" in the gradiometer electronics will always be present even with the best stabilized power supplies and will be a limiting factor in instrument sensitivity.

Vibrations from seismic and local ground activity cause the microbalance to tremble and oscillate slightly so that a steady null position is not achieved and "noise" is introduced in the output signal. In the laboratory, seismic and local ground disturbances can be substantially reduced by an isolated pier and/or operation in a seismically quiet location. Previous research and experience has indicated that a reduction in the noise level by a factor of at least ten is possible. This level will be a limiting factor in the gradiometer sensitivity.

The ultimate sensitivity of an improved instrument operated in a seismically quiet environment should certainly be of the order of 1 E.U.

#### D. DISTURBING EFFECTS ANTICIPATED IN THE FIELD

A portable field gradiometer can be expected to incorporate improvements to eliminate or minimize most disturbing effects. These disturbances are not likely to be as severe in the field as in a laboratory. Variable electromagnetic fields are not likely to be encountered and magnetic anomalies are not expected to cause trouble. The battery power supply of a portable instrument will present a lower level of voltage fluctuations than the line voltage in a laboratory. In remote areas where surveys are usually made, the local seismic activity is generally low. The vibration level is expected to be significantly lower than the best conditions experienced in the General Oceanology laboratory, but not as good, of course, as on an isolated pier. The gradiometer should have a sensitivity resolution approaching 1 E.U. which is the limiting sensitivity indicated in Section C above. The measurement accuracy may be an order of magnitude less because of disturbing environmental factors.

Disturbing effects on a field gravity gradient survey are not limited to seismic, electrical, etc. disturbances. Small variations in nearby topography, small nearby buried masses or a small error in leveling may have large effects on the local gradient. These local variations will appear as "noise" on a gradient profile over a larger geological structure. Figure 13 shows that a small nearby mass may have more of an effect on the local gradient than a large distant mass (Balavadze, 1955). In gradient surveying, a limiting factor for the accuracy of gradient measurements will be the precision with which the average gradient can be extracted from the gradient noise.

Considering all factors, an accuracy of 5 to 10 E.U. is anticipated for land gradient surveys.

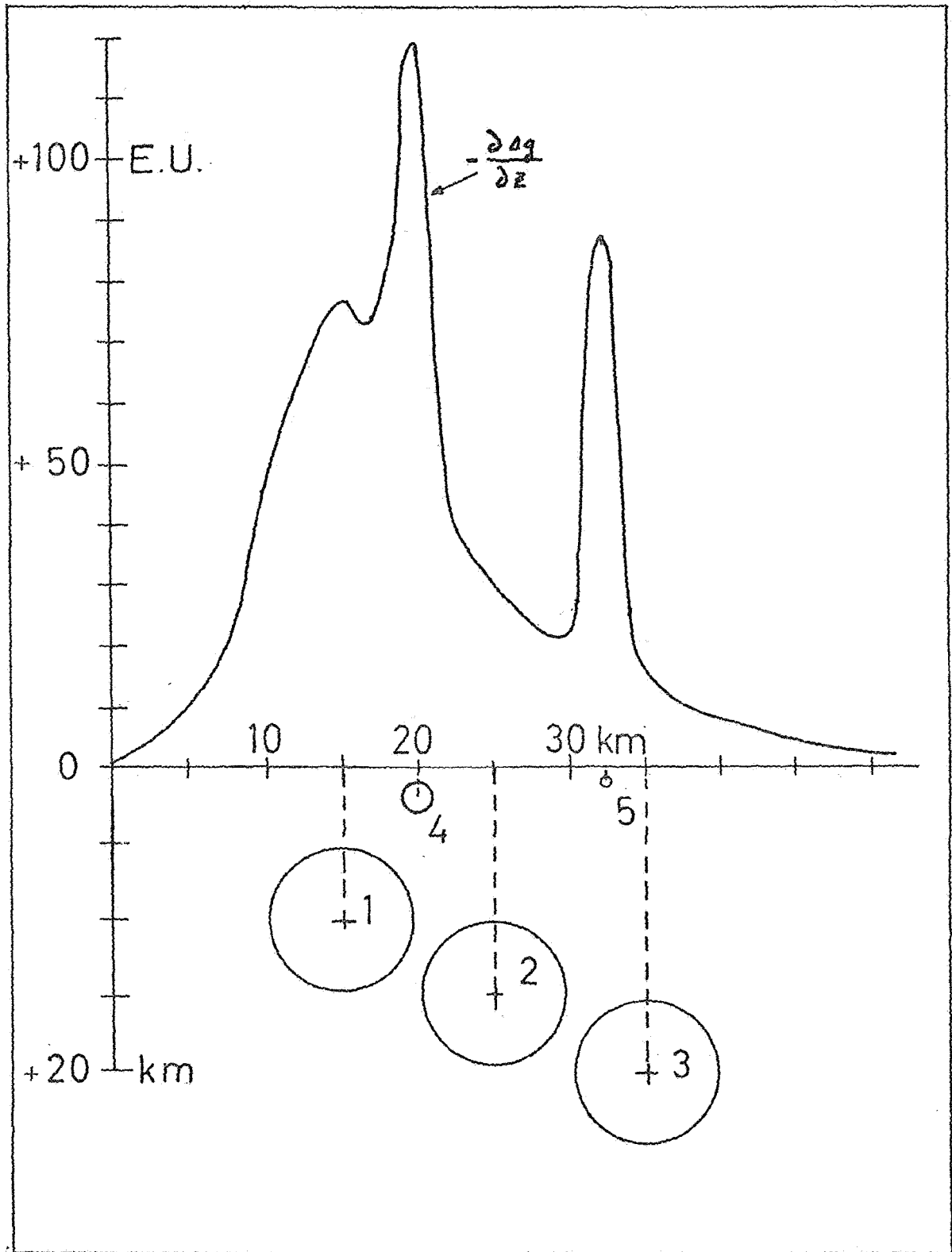

Figure 13. Vertical Gradient Anomaly Profile for 5 Subsurface Spheres (from Balavadze)

## E. DISTURBING EFFECTS IN A SPACE VEHICLE ENVIRONMENT

Problems of seismic, geologic and topographic noise that plague land gradient measurements disappear in a space vehicle environment. However, other serious effects are introduced by reason of orbital angular acceleration gradients and centrifugal acceleration gradients from vehicle rotation. The orbital application and operation of a microbalance type gradiometer is discussed in more detail in a following section. The significant point of interest here is that in the extremely quiet environment of space, an improvement in instrument sensitivity by a factor of at least ten can be expected. Sensitivities of 0.5 to 1.0 E.U. or better should be possible.

## F. ANOMALY DETECTION CAPABILITY OF GRADIOMETER

### 1. General

Since the gravity coverage of the world is still very incomplete, it is difficult to find many examples of large topographic and geologic features that have adequate surface gravity data over them for gravity gradient calculation purposes. Therefore, model cases have been used to calculate gravity effects over geologic features.

Geologic structures equivalent to the observed proof mass gradients have been examined to illustrate the effectiveness of using a small proof mass to represent a large geologic feature. Using model cases, the magnitude and character of vertical gradients are presented for representative geologic structures. Finally, given the expected measurement sensitivity of the instrument for earth-land and moon-orbital surveying, the resolution capability of the microbalance gradiometer is discussed.

### 2. Geologic Structures Equivalent to Proof Mass Anomalies

Several geophysical models are used to calculate the mass and depth of burial of a body necessary to produce gradient

anomalies equivalent to those measured over the proof mass, and to suggest corresponding geologic structures. Appendix B gives the equations for calculating gravity and gravity gradient anomalies for simple shapes. For more complicated shapes, the two-dimensional polygon method and computer program of Talwani (Talwani et al, 1959) is used.

The equivalent vertical gradients measured over the two experimental proof masses, the cube and the slab, have peak values of 500 E.U. and 617 E.U. respectively. For a density contrast of  $1.0 \text{ gm/cm}^3$ , a spherical mass of 1 km radius buried 37 meters below the surface would give a peak vertical gravity gradient of 500 E.U. The gradient would increase with decreasing distance from the surface of the mass, finally reaching a maximum of about 560 E.U. at the surface. The gradient rapidly decreases with increasing distance from the sphere and reaches a value at two radii of  $1/8$  of the gradient value at the surface of the sphere. (See Figure 9). A 500 E.U. vertical gradient could also be generated by a similar, but cubic, mass measuring 1.6 km on a side and lying 230 meters below the surface. A vertical right circular cylinder of approximately the same dimensions as the cube, buried 240 meters below the surface would also produce a 500 E.U. vertical gradient. A horizontal cylinder with a radius of 1 km could be buried 320 meters and yield a similar gradient.

In geologic terms, the proof mass measurements are equivalent to mapping the vertical gradient over a 1 km-radius spherical ore body buried 100 feet below the surface. The case of the vertical cylinder is equivalent to measuring gradients over the top of a large granite plug or over the top of a seamount. The horizontal cylinder model may be interpreted as the equivalent of detecting an anticline or syncline buried nearly 1,100 feet below the surface.

### 3. Typical Geologic Structures

500 E.U. must be considered a large gradient anomaly for most geologic structures. The expected range of gradient anomalies for surface-land surveying would be 20 to 100 E.U. for typical geologic features. Figures 14 through 17 illustrate the dependence of the magnitude and character of the vertical gradient on height and horizontal distance from various shaped bodies. The calculations assume that the anomalous mass is of infinite extent along the axis perpendicular to the body outline.

Figure 14 shows the vertical gradient over a trapezoidal body buried 1/2 km below the surface level. Note that for a surface traverse the gradient maximum is not associated with the center of mass. However, for increasing heights above the body, the peak value migrates toward the center of mass. For a horizontal cylinder, illustrated in Figure 15, the peak value does indicate the location of the center of mass. Figure 16 presents profiles of the vertical gradient caused by a buried peak. The magnitude of the gradient on the surface of the ridge-peak is about 360 E.U. Figure 17 shows the calculated profile of the vertical gradient across a fault structure, which in this case represents the transition from the ocean basin to the continental platform. The vertical gradient is antisymmetric with respect to the line of strike, is zero at the line of strike, and reaches a maximum near the edge of the structure.

### 4. Resolution of Gradient Anomalies for Earth-Surveying

In view of the limiting accuracy of 5 to 10 E.U. expected for field operation of the gradiometer, the minimum detectable gradient anomaly would be 20 to 30 E.U. With a detection capability of this magnitude, a spherical mass 1 km in radius with a density contrast of  $1.0 \text{ gm/cm}^3$  would be detectable at a depth of 1-1/3 km. A vertical cylinder of the same total mass would be detectable at a 3 km depth. In terms of geologic features, (See Figures 14 through 17) a salt dome, a mafic intrusion, a large fault structure, and a mid-oceanic ridge would all be detectable features.

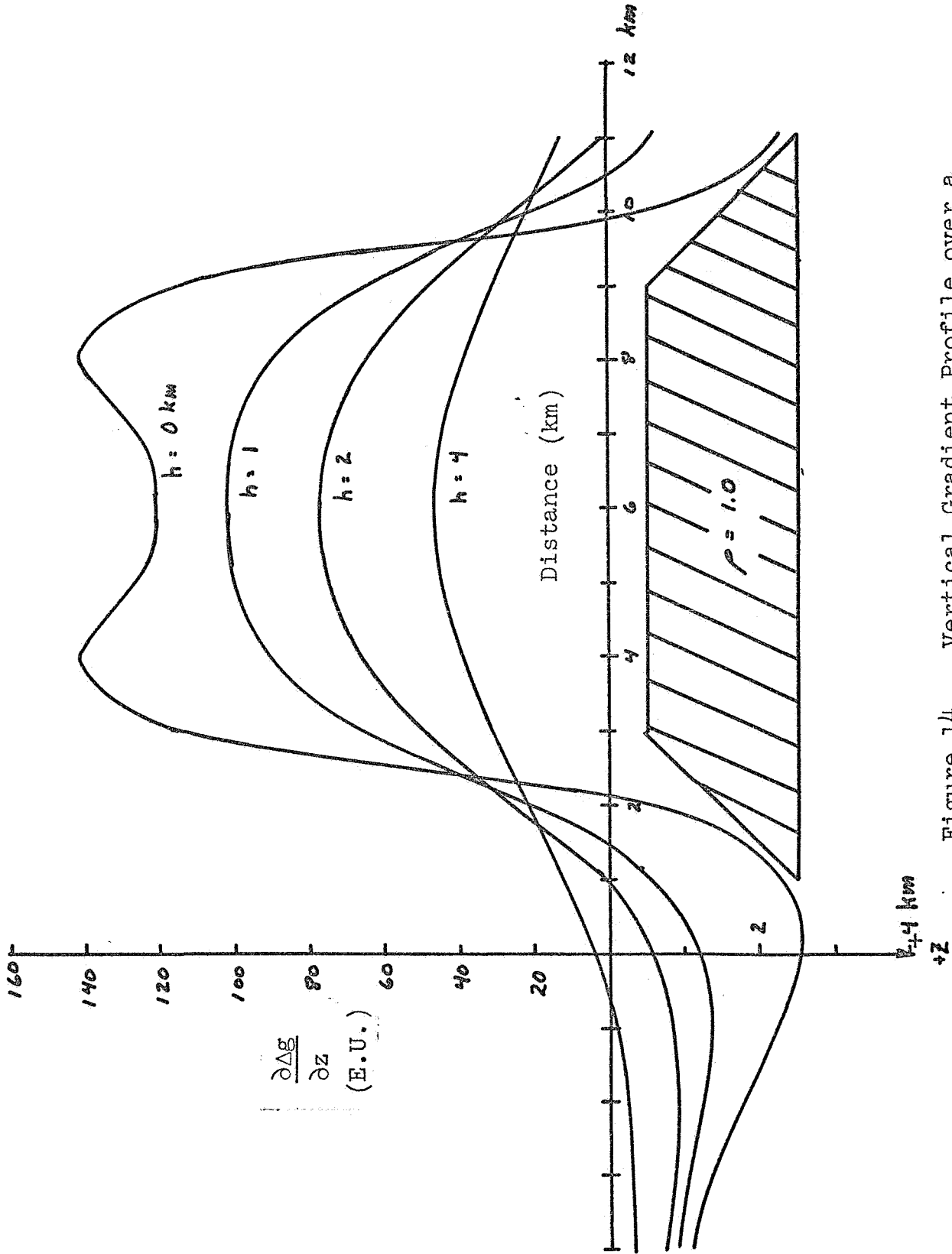

Figure 14. Vertical Gradient Profile over a Two-Dimensional Trapezoidal Body.  $h$  is the Height above Ground Level ( $Z = 0$ ).



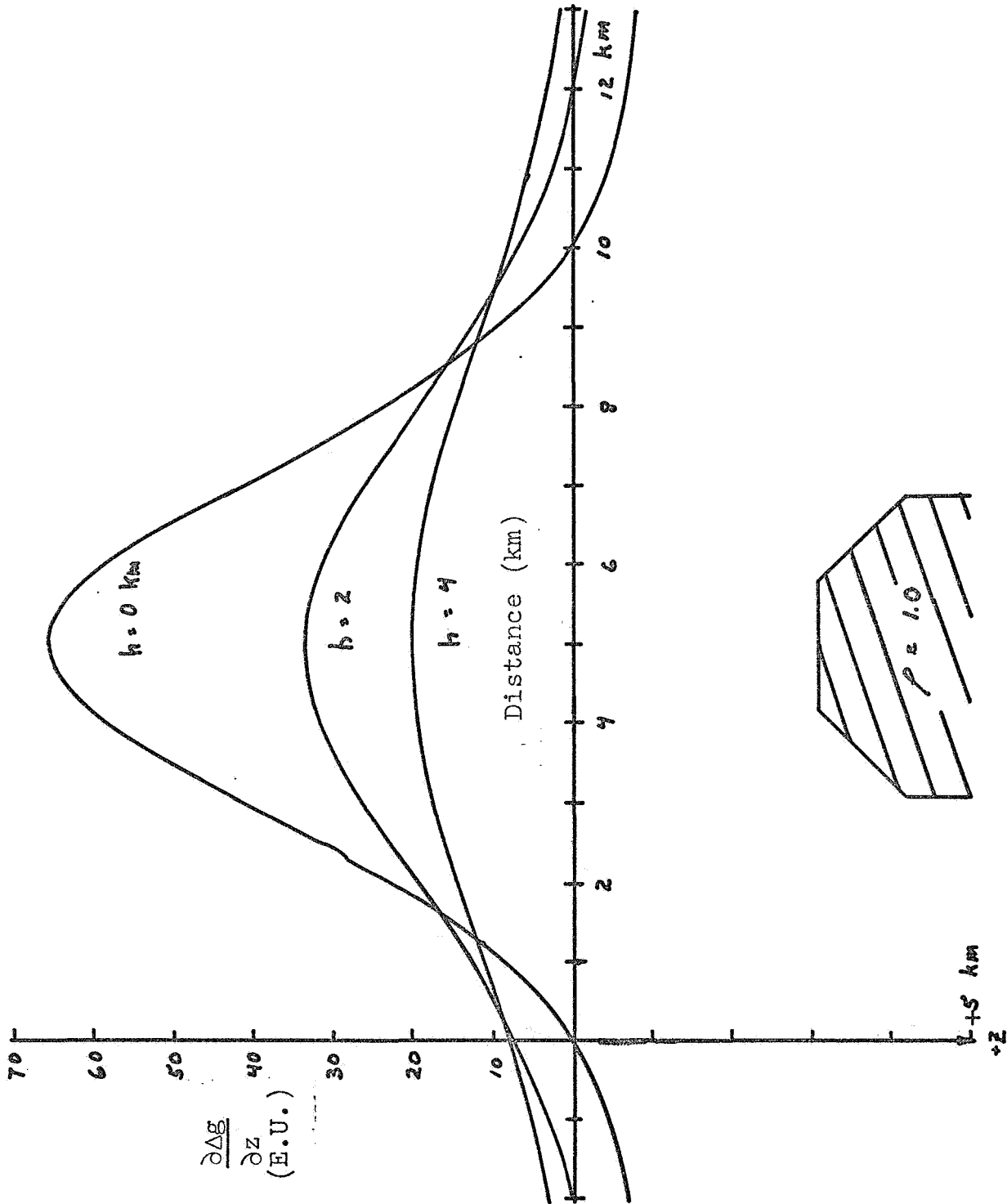

Figure 15. Vertical Gradient Profile over a Horizontal Cylinder.  $h$  is the Height above Ground Level.

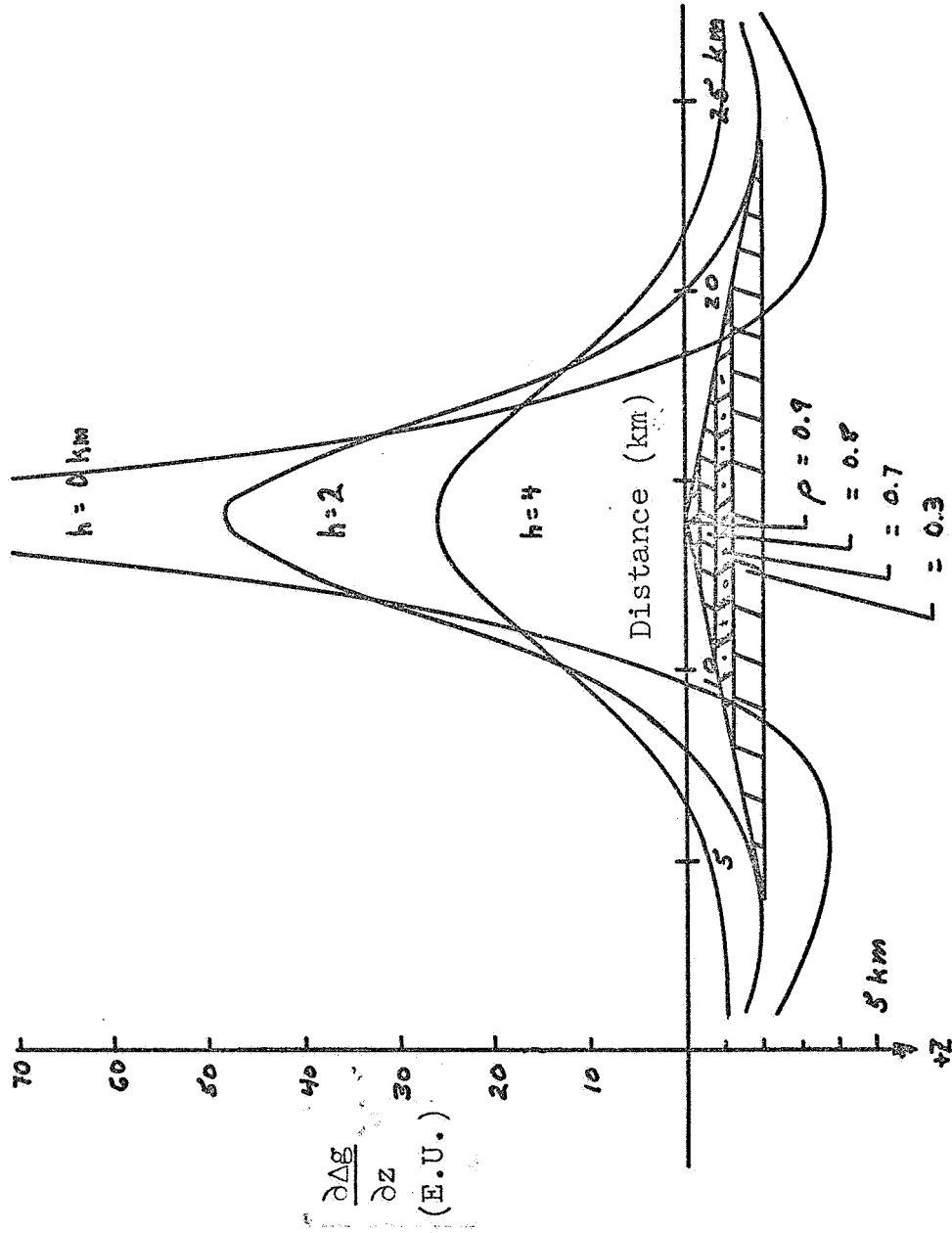

Figure 16. Vertical Gradient Profile over a Buried Mountain Ridge.  $h$  is the Height above Ground Level.

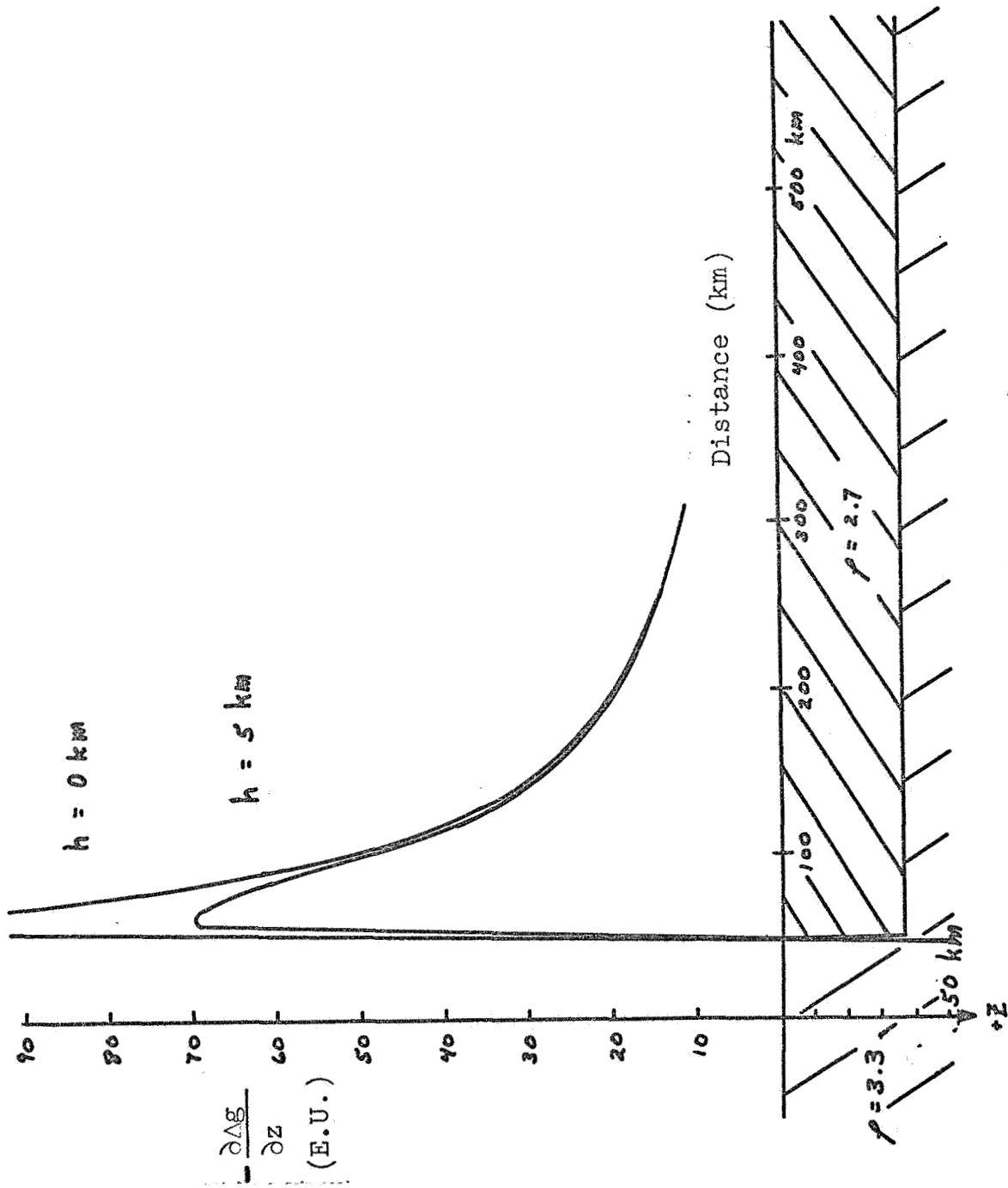

Figure 17. Vertical Gradient Profile over a Fault Structure.  $h$  is the Height above Ground Level.

## 5. Resolution of Gradient Anomalies from a Lunar-Orbiting Vehicle

For a moon orbit with gravity gradient instrumentation capable of an accuracy of 0.5 to 1.0 E.U., the minimum amplitude of gradient anomaly which will be detectable is on the order of 3 E.U. The resolution capability for an orbital instrument depends not only on the magnitude of the smallest detectable anomaly, but also on the minimum integration time of the instrument.

The orbital velocity of a vehicle in a 65 km orbit about the moon is approximately 3 km/sec. Given an integration period for the gravity gradiometer of ten seconds, at least 30 seconds are required for the detection of a minimum anomaly. In a moon orbit at 65 km, this means that the anomaly must be at least ninety kilometers wide and have an amplitude of 3 E.U. This indicates that anomalies from most sources, except the smallest features which may be encountered in mining, will be detectable in orbit around the moon.

The major topographic and geologic features of the moon are the maria, the mountains, and the craters. These features have sufficient physical extent to be detected as anomalies in gravity gradient at orbital altitudes providing they are associated with density contrasts comparable to those found associated with such features on earth. The maria seem to correspond to our oceans except that they lack water. If the maria and non-maria areas are geologic analogs to oceanic and continental areas on the earth, there should be an expected density contrast similar to that observed on passing from oceanic areas to continental areas.

Figure 18 illustrates the gradient profile at a 65 km orbital height over an oceanic to continental transition zone.

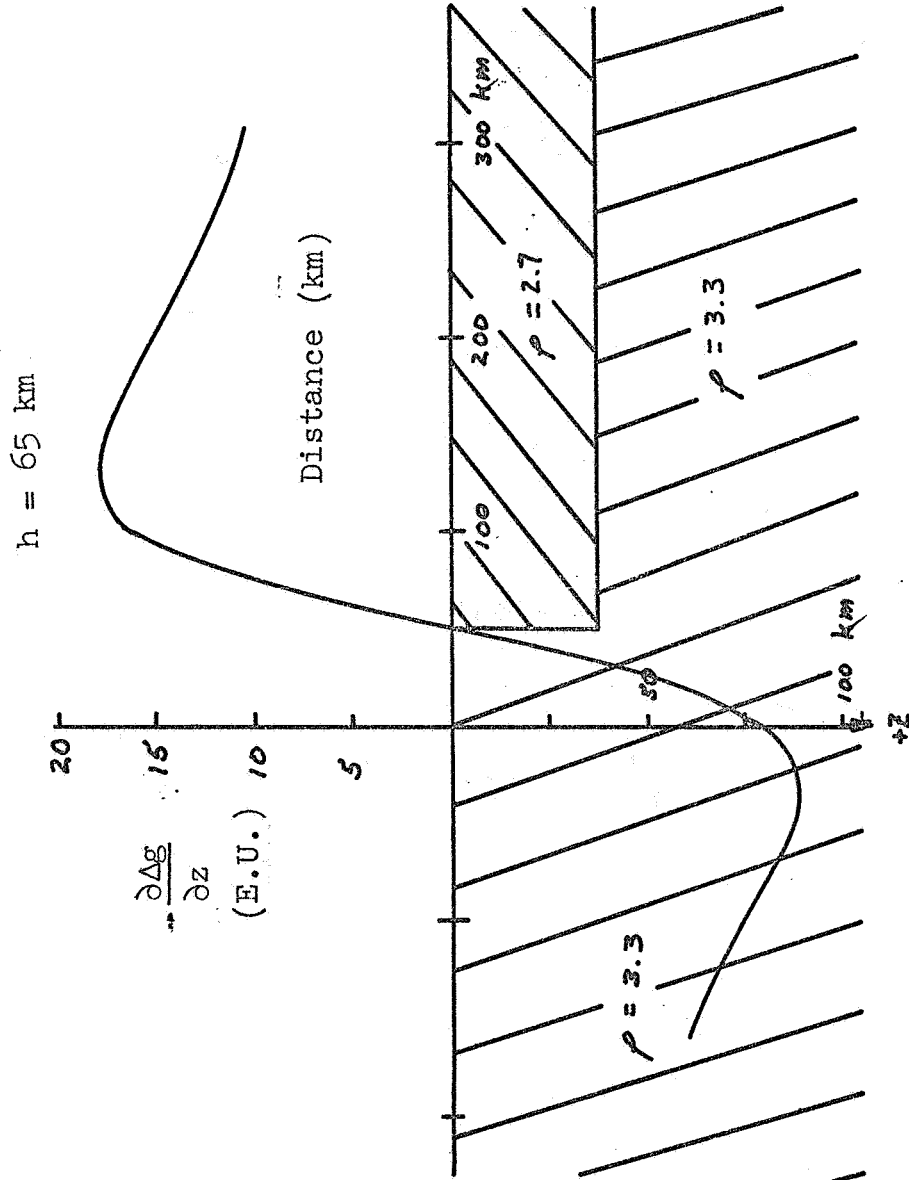

Figure 18. Vertical Gradient Profile over an Oceanic-Continental Transition Zone for a 65-km Lunar Orbit

An upward continuation of previously considered gravity gradient anomalies to orbital altitudes for large geologic features on the earth indicates that the anomalies on the moon have amplitudes of 3 to several tens of E.U. at an orbital altitude of 65 km. Assuming a gradiometer accuracy of 1.0 E.U. and an integration time of ten seconds, such anomalies are detectable in an orbit about the moon providing that density contrasts comparable to those found on earth exist on the moon. Mountain ranges and large crater relief, density contrasts within the moon's crust, continental versus maria masses (if a density contrast exists), and undulations in the Moho (if present) all constitute detectable features for a moon orbit.

## VI. PRELIMINARY CONSIDERATIONS OF MICROBALANCE GRADIOMETER FOR ORBITAL SPACE VEHICLE APPLICATIONS

### A. GENERAL

A serious problem is posed by the conflict between the selection of the most desirable gravity gradient quantities to be measured on a space vehicle (for the simplest measurement and interpretation) and the ability to do so because of instrumentation difficulties and disturbing orbital acceleration effects. The fact that the complete "gradient of gravity" is represented by a tensor with nine second-partial derivatives (terms or quantities) of the gravity potential is well known. The derivation and geophysical meaning of the terms is briefly presented in Appendix C. The difficulty of measuring any or all of these quantities on an orbiting vehicle has been previously analyzed (Arma, 1966). The significant point here is that the vertical gravity gradient,  $U_{zz}$ ,

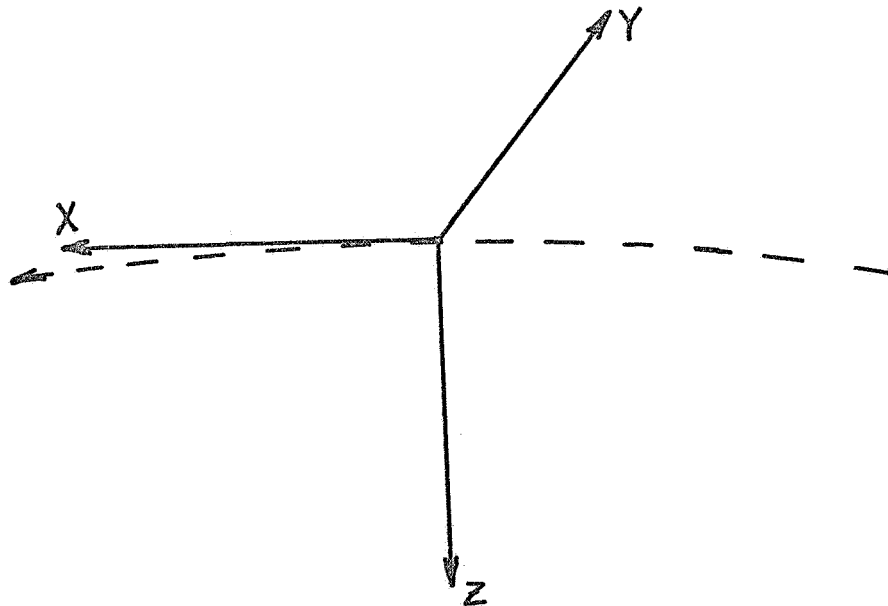

Figure 19. Axis Orientation for Orbital Space Vehicle Applications

(See Figure 19 for the orientation of axes) is the preferred quantity to measure because it is a simple quantity to measure and is the only quantity required for simple and direct interpretation of anomalies. Thus, the potential application of the microbalance vertical gravity gradiometer, which has been shown to work well on earth, is of particular interest.

It must be emphasized that the following discussions are only preliminary in nature. A detailed analysis of a space instrument system based on the microbalance gradiometer was not a part of this investigation.

#### B. ORBITAL OPERATION OF MICROBALANCE

Any orbital gradiometer (or gradiometer system composed of a number of sensors) is subject to measurement errors from orbital angular acceleration gradients and centrifugal acceleration gradients induced by vehicle rotation. In studying the feasibility of orbital gradiometer measurements Arma (1966) has concluded that:

(1) "In order that meaningful measurements of the gravity gradient may be made, the use of a platform stabilized in inertial space will probably be required.

(2) It is feasible to measure only the longitudinal components of the gravity gradient. These are the principal diagonal terms of the gradient tensor. The off-principal diagonal or cross-gradient terms are not readily susceptible to physical measurement because of their associated errors produced by extremely low angular accelerations in inertial space."

The operation of a microbalance gradiometer in orbit involves additional problems peculiar to this type of device. The microbalance gradiometer has several masses hanging freely on the ends of flexible quartz fibers and the balance arm itself is hanging from a pair of hinge fibers. The operation of the microbalance is best considered for both vertically stabilized and space stabilized cases. Since the microbalance is truly a vertical gravity gradient



measuring device, a vertically stabilized instrument is a logical first choice for consideration. Neglecting for the moment the instrument rotation caused by constant torquing to hold it in the local vertical and assuming the instrument is aligned in the local vertical, the balance mechanism proper must be positioned some distance below the center of mass of the complete instrument package in order that sufficient force be created by the gravity gradient of the planet being orbited to stretch the supporting fibers. The balance mechanism then hangs and operates as it does on earth. A simplified diagram of such an instrument package is shown in Figure 20-a. The force acting on the balance mechanism and its masses would be quite small compared to that at the surface of the earth. In particular, the gravitational acceleration acting on the masses would be equal to the existing gravity gradient times the distance of the mass under consideration from the center of mass of the instrument package. This is equivalent to using very small masses in a microbalance on earth. This does not affect the operation of the microbalance and does not change the calibration or sensitivity of the instrument.

For an orbital application where 10 gm masses do not cause a "heavy" loading of the suspension fibers, an alternative design would be to use a torsion fiber suspension as illustrated in Figure 20-b (based on previous proprietary research of Dr. Lloyd G. D. Thompson). In this case, the center of mass would be at the center of the instrument system and the upper mass would be level with the center of mass or could even be on a fiber extending upwards a distance equal to that of the lower mass. The masses would remain extended by reason of the gravity gradient and the balance arm would be rotated proportional to the opposing moments of forces created by the gravity gradient.

Theoretically, in the case of perfect vertical stabilization in a circular orbit, the gravity gradiometer should work perfectly and the centrifugal acceleration gradient due to instrument

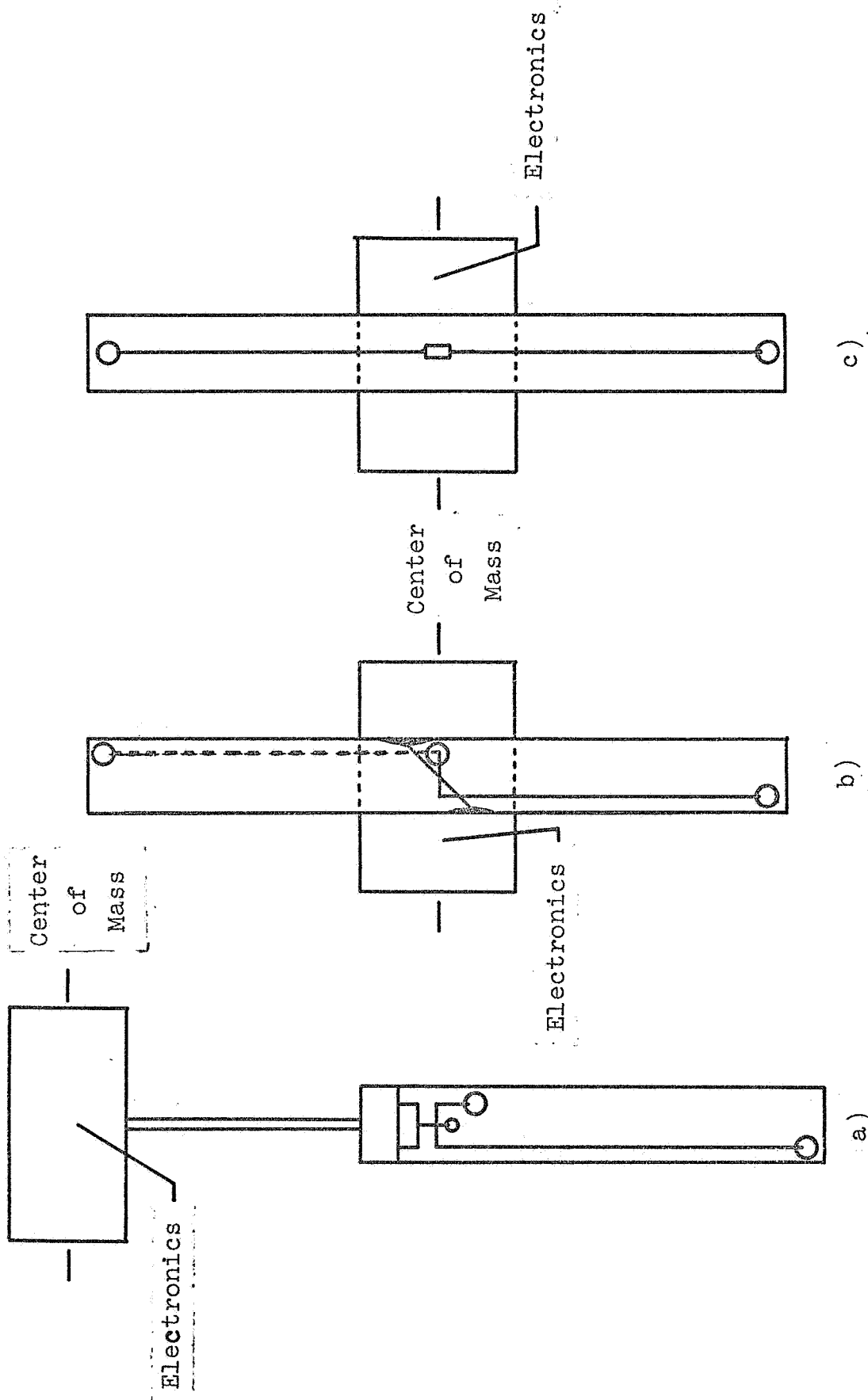

Figure 20. Possible Gradiometer Configurations for Space Vehicle Applications.  
a) - microbalance, b) - torsion balance, c) - semi-conductor crystal balance

rotation and the orbital angular acceleration gradient would be constant and would be sensed as a fixed DC signal bias in the gradiometer output. Short period gravity gradient anomalies would be measured as changes from this level. However, it is quite evident that in a vertically stabilized instrument, the instrument rotation and its variability will cause disturbing effects and errors which leave some doubt as to the behavior of the freely hanging fibers and masses. Thus, the proper operation of the balance becomes speculative. Further consideration of this type of instrumentation at this time leads to an improbable, although not impossible, situation.

Although a space stabilized vehicle is considered the best environment for the operation of gradiometers, (Arma, 1966) continuous measurement of the vertical gravity gradient is not possible without a set of properly aligned sensors. If a single gradiometer were adequately stabilized in the orbital plane, it would be in the local vertical twice each orbit at which time it would measure the vertical gravity gradient, while at two other points it would be perpendicular to the vertical at which time it would read zero (Arma, 1966). At other points in the orbit, it would measure a combination of the gradient components. With the microbalance gradiometer, an added problem arises from the freely hanging fibers and masses. In the presence of the gravity gradient of a planet, the masses will tend to align themselves in the local vertical (i.e. the principal of gravity gradient stabilization). When the gradiometer is horizontal, the fibers and masses are particularly free to move since the fibers cannot withstand a compressional force. Thus, without further knowledge as to the behavior of a microbalance system under these conditions, the instrument design appears to be incompatible with the space stabilized case.

Another gradiometer of fundamental design which is also the result of previous proprietary research and development of Dr. Lloyd G. D. Thompson, appears, however, to be appropriate for a space stabilized system. As shown in Figure 20-c, the gradiometer is a dumbbell consisting of two large masses separated by a rigid rod with a specially developed semi-conductor crystal at its center to measure minute tensional and compressional forces. Large masses with a large separation can be used to give increased sensitivity. It is also possible to "fold" this device into a microbalance for calibration and use on the earth in a one-g field.

In summary, the microbalance gradiometer appears to be a simple, potential instrument for measuring the vertical gravity gradient in an adequately vertically stabilized orbital mode. In view of present technology which does not permit extremely accurate vertical stabilization, however, the microbalance gradiometer does not appear to be useful in its present simple form. This does not preclude the development of a modified design of the gradiometer with more rigid construction having application for either space stabilized or vertically stabilized cases. Two suggested designs of proprietary development of Dr. Lloyd G. D. Thompson have been presented here. Other proprietary designs of a rigid nature have also been considered which may be more suitably applied. The development of a design of the microbalance gradiometer for orbital space applications was not a subject of this investigation but should be an area for further investigation in view of the successful demonstration of the instrument as a gradiometer.

### C. POSSIBLE VEHICLE/INSTRUMENT CONFIGURATIONS

Although the application of the microbalance gravity gradiometer to orbital flight has its own peculiar problems, certain other features of orbital flight pertain to any vertical gradiometer and influence the ways in which an experiment can be carried out. Assuming an Apollo mission to the moon, there are three possible ways which may be considered whereby a vertical gravity gradiometer

may be used in orbit, namely, (1) on the manned spacecraft, (2) tethered to the manned spacecraft, and (3) as a separate probe or package which could be cast off from the manned spacecraft to orbit independently.

The manned spacecraft approach has the disadvantage of disturbing gravity fields and gravity gradients from the vehicle mass distribution, astronaut movement, fuel depletion, etc. But it also has several advantages. The space vehicle attitude control and central data recording, storing and transmitting equipment would not have to be duplicated in the gradiometer package so that a simpler instrument could be used. A simplified experiment could be performed because the astronaut could perform sequential steps to put the gradiometer into operation, check its performance, and make measurements at opportune times. The instrument could be located in a remote position on the spacecraft to minimize gravitational disturbance.

The separate satellite package is perhaps the best approach for gradiometer operation but this necessarily includes problems of stabilization, data telemetry, remote operation, packaging, etc. This package could be cast off from a manned vehicle under opportune or ideal conditions and monitored while in a nearby position to check its performance. This approach has the distinct advantage of continuous operation (assuming a suitable gradiometer is available) by leaving it in orbit to eventually obtain full coverage of the moon. The data would be telemetered to the command spacecraft for storage and later transmission to earth or to similar central data receiving and storage equipment on the lunar surface.

The tethered concept lies somewhere between the other two concepts. It is an attempt to eliminate the environmental disturbances within the spacecraft but does not achieve the full freedom of an independent satellite because of the tether. Unless there is a

particular importance attached to the recovery of the gradiometer package (which is doubtful for a relatively inexpensive instrument), the tethered concept has little to offer.

#### D. LUNAR SURFACE SURVEY APPLICATIONS

The successful operation of the microbalance gradiometer depends on its being stabilized in the local vertical (with little or no translational velocity relative to the anomalous mass being detected). The achievement of this condition in orbit seems unlikely with present technology, but the development of a portable surface gradiometer is clearly merely a question of time. Hopefully, a prototype of such a field exploration instrument will be developed as a continuing effort of this research program.

A vertical gradiometer has several advantages over a regular gravity meter for exploration purposes. The most significant are:

1. The gradiometer is insensitive to linear inertial accelerations that disturb a gravity meter.
2. Precise elevations are not necessary as in normal gravity surveys, because the vertical gravity gradient changes very slowly with altitude and is essentially constant over several feet or even tens of feet.
2. Gradient surveying removes regional trends and therefore provides high resolution of local anomalies of interest.

These advantages, particularly the elimination of the need for precise leveling which simplifies the survey procedures, are strong support for the use of a gradiometer for surface surveying on the moon. It would be of particular benefit and use for the planned mobile vehicle traverses.

## VII. CONCLUSIONS

From the preliminary laboratory experimentation performed with the microbalance gravity gradiometer, the following conclusions can be drawn:

1. An available off-the-shelf quartz microbalance can be modified in design and sensitivity to make vertical gravity gradient measurements.

2. A suitably modified version of the currently available microbalance, but without improvements to overcome undesirable disturbing environmental effects, has a resolution of about 10 E.U. and an overall measuring accuracy of about 90 E.U. Most of the error in measurement is directly attributable to errors caused by disturbing environmental effects. The modified microbalance, as used in this experimentation, is the first instrument of this type to make vertical gradient measurements.

3. With improvements to eliminate or minimize disturbing environmental effects, the resolution of the microbalance gradiometer can be increased to about 1 E.U. and the measurement accuracy to 5 to 10 E.U. under quiet conditions. The required improvements can easily be made. Added experimentation with the higher measurement accuracy would be meaningful and significant.

4. Microbalance vertical gradient measurements over proof masses in the laboratory are not exactly the same as vertical gradient measurements in the field because of the size relationship of the instrument and the anomalous mass. However, the successful performance of the instrument in one case, verifies its performance in the other. "Equivalent" gradient measurements with the microbalance gradiometer were made over lead cube and lead slab proof masses to an accuracy of 90 E.U. and with an instrument resolution of 10 E.U. The measured gradients agreed with calculated values within the experimental error. The tests simulated gravity and gravity gradient effects over geologic structures such as salt domes, intrusive plugs, lenticular lava flows, faults and concentrated heavy mineral deposits. This is the first time that such vertical gravity gradient measurements have been documented using a modified commercially available microbalance.

5. A microbalance gradiometer can be calibrated easily and accurately in the laboratory using proof masses. For example, if vertical gradients can be calculated to 1 E.U., a 12" lead cube can give an equivalent vertical gradient of 500 E.U. or a calibration accuracy of 1 part in 500. A similar proof mass with a 3" hole through its center could give a total differential gradient of about 1,000 E.U. or an accuracy of 1 in 1,000. Calibration accuracies of 1 in 3,000 are possible with larger proof masses.

6. A portable field exploration microbalance gradiometer can readily be designed and fabricated having a resolution of about 1 E.U. and a measuring accuracy of 5 to 10 E.U. This instrument would permit field test measurements over typical geologic structures.

7. The basic microbalance is sensitive to many disturbing environmental effects. State-of-the-art improvements can easily eliminate or minimize most of the disturbing effects caused by variations of temperature, pressure, magnetic fields, electromagnetic fields, power fluctuations and tilt. The most significant disturbing effects that limit the resolution (sensitivity) of the laboratory microbalance are: (1) "noise" in the electronics and power supply voltage fluctuations both of which cause variations in the force-balance output signal, and (2) vibrations from seismic and local ground activity which cause the balance to oscillate about its null position and increase the "noise" level in the output signal.

8. In the field, there is an added problem which affects the survey accuracy. High amplitude, high frequency gradient anomalies from local nearby small masses are likely to be encountered. These nearby masses will cause large variations in the gradient from point to point which would appear as large spikes on a broader anomaly. This "gradient noise" might make it difficult to determine the average gradient representing the anomaly of interest.

9. For orbital spacecraft applications, the microbalance gradiometer in its present configuration is not particularly suitable for vertical gravity gradient measurements unless it can be adequately stabilized in the local vertical. Other similar alternate designs may, however, prove more applicable.



10. A portable microbalance gradiometer, which is the next logical design step, has immediate and important applications for surface exploration of the moon.

11. The successful use of existing off-the-shelf instrumentation for vertical gravity gradient measurements is significant cause to reconsider vertical gravity gradiometers for geophysical exploration and, in particular, for lunar surface exploration within the Apollo Applications Program. The preliminary results of this experimentation will aid in defining a future orbital spacecraft gravity gradient experiment.

VIII. RECOMMENDATIONS

As a result of the successful gradient measurements performed under this preliminary task, additional work areas for a follow-on program are recommended as follows:

1. Advanced Gradiometer Laboratory Experimentation

In view of the recognized potential superior performance capability of the microbalance gradiometer, it is recommended that the work program with the microbalance be extended for six months to one year to permit additional advanced experimentation and laboratory model tests with the microbalance configured and set up to minimize disturbing environmental effects and to give optimum measuring sensitivity and accuracy. Proper preparation of the microbalance would include such pertinent features as (1) isolation from local seismic disturbances (an isolated pier or seismically quiet laboratory facility), (2) shielding from magnetic and electromagnetic fields, (3) constant temperature environment, (4) high vacuum capability (Vac-Ion System), (5) elimination of line voltage fluctuations (constant voltage power supplies), (6) improved integral balance system of weights, fiber element, (7) use of potentiometer strip chart recorder for output, and (8) a displacement measuring technique for the output instead of a force method. Some other modifications to the hardware will, of course, be necessary.

At the high sensitivity of this improved instrument, effects from gravity tides may be noticeable. It would, therefore, be desirable to have a recording earth tide gravity meter set up in the laboratory to monitor tidal variations during this experimental period. This earth tide meter could also be used beneficially in any gravity field test program.

All of these modifications could be readily accomplished. The added research would represent a significant improvement in gradiometer capability which should be capitalized upon throughout the future gravity gradient research program. The results of

additional laboratory model studies and measurements would be much more accurate and significant for application to a space flight gradiometer experiment. This added research is considered very worthwhile and, in fact, is a logical second phase of the overall program. With the increased reliability and stability achieved by this improved instrumentation, it will also be possible to perform an experiment (after Jolly) to determine the actual total vertical gravity gradient of the earth at the laboratory site. This also offers the possibility of relating relative gradient measurements to the total earth's gradient.

The microbalance gradiometer is now operating extremely well (but within its limited capability), therefore, it would be advantageous and beneficial to start the added research and laboratory model studies as soon as possible to take advantage of the current operating state of the microbalance.

## 2. Prototype Transportable Field Gradiometer

An important follow-on phase of this laboratory experimentation is the design, development and fabrication of a prototype transportable field gradiometer. This is justified and definitely recommended in view of the successful laboratory demonstration of the microbalance as a gradiometer. Additional experimentation is required for the establishment of design parameters and the subsequent development of a portable instrument. This work could be done beneficially in conjunction with the advanced experimentation recommended in Item 1 above. The latter, in itself, would aid in the development of the required design features. The portable field gradiometer would be a completely new instrument fabricated according to the resulting design specifications. Fabrication of the gradiometer element and other appropriate parts of the instrument would necessarily be done by Worden Quartz Products, Inc., according to the design specified by Dr. Lloyd G. D. Thompson.

3. Gravity Gradiometer Field Test Survey

A logical and desirable continuing part of the gravity gradient program would be to first test the portable field gradiometer both in the laboratory and on short field trials, then perform a vertical gravity gradient field survey over a known geologic feature on the earth's surface. This test survey should be done over an area for which gravity data is already available for comparison purposes. This could be the same area surveyed as another part of the work under this contract or could be any other suitable area of interest. If gravity data are not available, they could be readily obtained during the same survey.

For this gravity gradient survey, it would be desirable to have a recording earth tide gravity meter to provide a record of the daily gravity variations.

This work could be done in conjunction with and in support of the NASA MSC mobile-van seismic field program.

4. Analysis of Gradiometer Applied to Orbital Instrumentation System

Although the microbalance gradiometer has proven successful, present preliminary investigations did not permit serious consideration of the application of this type of instrument to orbital conditions. Therefore, it is recommended that a follow-on program include a more detailed analysis of the microbalance instrument design applied to orbital instrumentation systems for vertical gravity gradient measurements.

5. Analysis of Gradiometer for Lunar Surface Exploration

The microbalance gradiometer in its forthcoming portable field version can be seen to have immediate and important applications for lunar surface gravity exploration. Both hand-carried and mobile versions can be considered. The instrument's availability is a

completely new basis for considering it for lunar surface exploration. It is, therefore, recommended that new work include a detailed analysis of this type of instrumentation design applied to lunar surface exploration surveys.

6. Development of Simplified Gravity Gradient  
Space Flight Experiment

Notwithstanding the problems involved in recommendation above, it is evident that instrument technology has advanced to the state where earth-based instruments can be considered for space orbital applications. It is, therefore, appropriate and recommended that the next phase of the work under this gravity gradient program include the development of what might be best termed a "simplified gravity gradient spaceflight experiment" under the Apollo Applications Program. The sponsor of this program would logically be the Geophysics Branch, MSC. Dr. Lloyd G. D. Thompson, who originally suggested this experiment to NASA, would serve as principal investigator under contract.

## ACKNOWLEDGEMENTS

The pertinent discussions and contributions of William B. Chapman, Contract Technical Monitor, are gratefully acknowledged.

REFERENCES

1. Arma Division, American Bosch Arma Corporation, Gravity Gradient Instrument Study, Final Report, NASA 1328, August 1966.
2. Balavadze, B.K., *Izvestiya Akademiya Nauk USSR Seriya Geofizicheskaya*, No. 5, Moscow, 1955.
3. Grant, F.S. and West, G.F., *Interpretation Theory in Applied Geophysics*, McGraw-Hill, 1965.
4. Robens, E., The Effect of Thermal Gas Flow on Microbalance Measurements, paper presented at Eighth Conference on Vacuum Microbalance Techniques, Wakefield, Mass., June 1969.
5. Thompson, Lloyd G.D., Gravity Gradient Preliminary Investigations, Mid-Term Report, NASA Contract NAS9-9200, July 1, 1969.



## AUTO-NULL MICRO-BALANCE

MODEL 4302

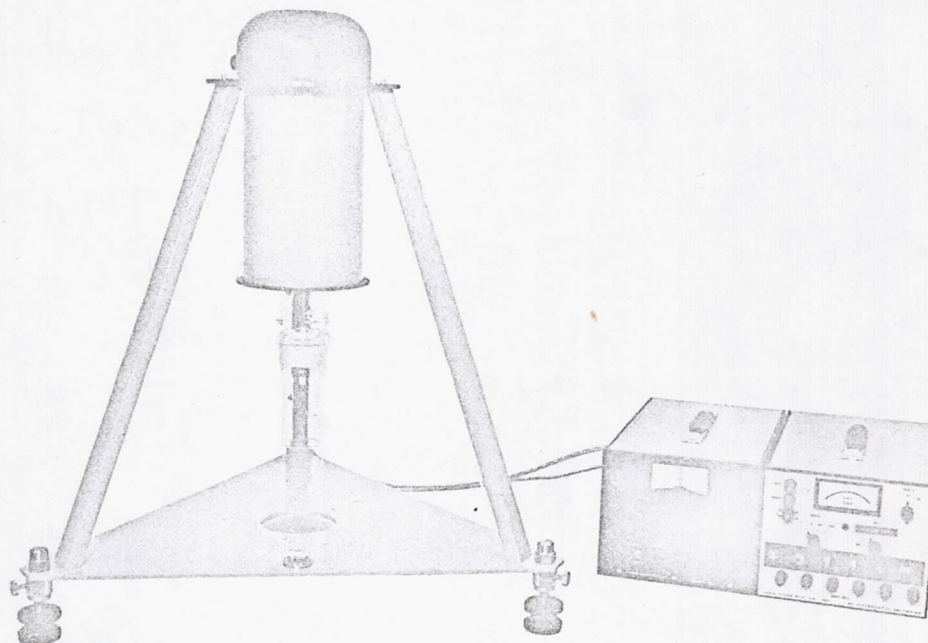

Precision weighing systems are comprised of combinations of balance elements and displays. The Worden Model 4302 balance system is of two-pan, equal-arm design combined with digital display and recorder output. Balance null position is maintained constantly through use of an electronic servo circuit that controls the torquing current in a pair of field coils on the balance.

The balance system enables the scientist to measure accurately small weight gradients in samples under investigation.

Thermo gravimetric analyses, mass sorption studies, and magnetic susceptibility<sup>1</sup> investigations are readily achieved using the Worden system. The Model 4302 also lends itself to mass comparisons and general analytical work. With special accessories, the system can be easily adapted for gas density measurements.

The balance element is fabricated from fused quartz, assuring long term stability. Vertical fused

quartz flexure hinges are used in place of knife edges, eliminating pivotal friction. Mechanical sensitivity is adjustable. Chamber configuration and O-ring seals are designed for high vacuum environment.

The Model 4302 is supplied complete with a solid state electronic nulling circuit for automatically maintaining balance null position. A two-position switch selects "MANUAL" or "SERVO" mode. Operation in the "MANUAL" mode is accomplished by rotating the null control knob until a null or zero reading is indicated on the panel meter of the control box. In the "SERVO" mode, nulling is accomplished automatically; i.e., the panel meter is maintained at the null position when weight changes occur by automatically controlled current in the field coils on the balance.

Microvolt/microgram readout is provided in a manually-operated digital display counter. Provision is also made for output to a recorder.

<sup>1</sup> Mulay, L. N., "Magnetic Susceptibility", Interscience Publication, John Wiley & Sons, New York, New York, 1966.



# AUTO-NULL MICRO-BALANCE

CONTINUED

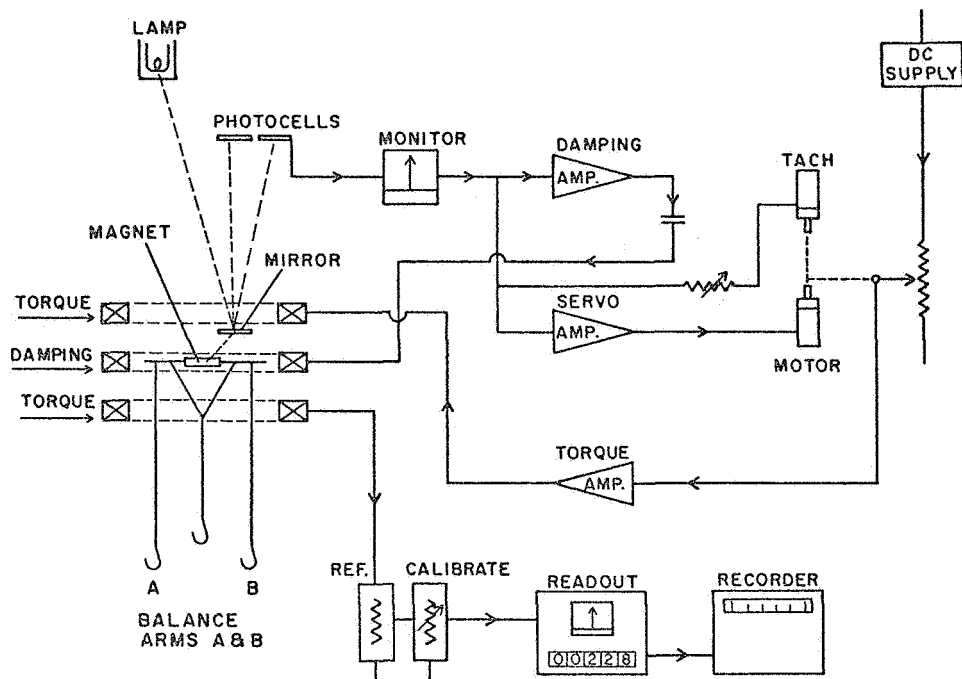

Maximum Sample Weight	10 gms
Minimum Sample Weight	0.1 gms
Total Delta Weight Range of Servo Controller	0-200 mg
Resolution	0.1 $\mu$ g (1 part in $10^8$ of maximum sample)
Precision (Standard Deviation)	0.7 $\mu$ g
Temperature Coefficient	1 $\mu$ g/ $^{\circ}$ C (under normal laboratory conditions)
Slew Rate	900 $\mu$ g/second maximum
Calibration	Microvolt readout instrument may be calibrated by user to read directly in micrograms.
Mechanical Sensitivity of Balance Element	Adjustable to infinity
Readout	Manual null of microvolt instrument with digital display. Potentiometric recorder (option).
Recorder Output	0-0.25 Volt (adjustable)
Materials Exposed in Chamber	Pyrex, quartz, Viton, gold, and palladium.
Power Requirements	110 Volt - 60 Hz

## OPTIONS

Cat. No. 4301-005-00 Sample Heater 110 volt 350 watts	Constant Voltage Transformer
Cat. No. 15-009 Temperature Controller with thermocouple	Potentiometric Recorder
	250 volt 50 Hz electrical service

APPENDIX B

Formulas for Calculating Gravity and Vertical Gravity Gradient Anomalies

1. Sphere or Point Mass: For a sphere or point mass the gravi-

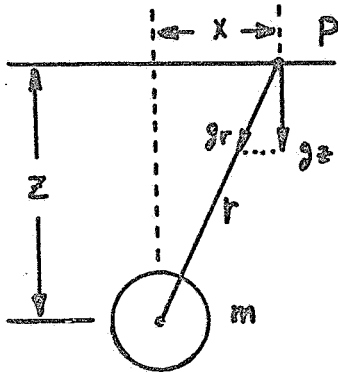

tational potential is  $U=Gm/r$  where G is the gravitational constant, m is the mass, r is the distance from the point of observation to the center of the sphere and z is the depth to the center of the sphere along the local vertical.

Gravity is 
$$U_z = \frac{-Gma}{r^3} = \frac{-Gmz}{(x^2 + y^2 + z^2)^{3/2}}$$

since 
$$r = (x^2 + y^2 + z^2)^{1/2}$$

and the vertical gravity gradient is 
$$U_{zz} = Gm \frac{(2z^2 - x^2 - y^2)}{(x^2 + y^2 + z^2)^{5/2}}$$

2. Horizontal Cylinder or Line of Elements: Using the same diagram and notation as for the case of the sphere we have:

$$U_z = 2Gm \frac{z}{r^2} = -2Gm \frac{z}{(x^2 + z^2)}$$

where  $m = \text{mass/unit length}$   
 $= \pi R^2 \sigma$

where  $R = \text{radius of the cylinder}$   
 $\sigma = \text{density contrast}$

also 
$$U_{zz} = +2Gm \frac{(z^2 - x^2)}{r^4} = +2Gm \frac{(z^2 - x^2)}{(x^2 + z^2)^2}$$

3. Infinite Horizontal Slab or Fault: A good approximation

method assumes that the material of the slab is condensed on a thin sheet at the mean depth of the slab as shown in the diagram.

For this case:

$\sigma$  = density contrast of slab

$\sigma t$  = density per unit area of thin sheet

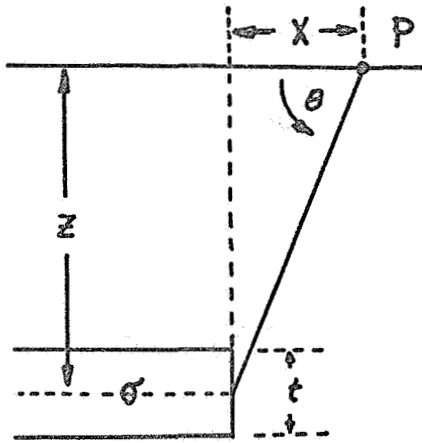

$$U_z = 2G\sigma t \left( \frac{\pi}{2} - \tan^{-1} \frac{x}{z} \right)$$

$$U_{zz} = -U_{xx} = -2G\sigma t \frac{x}{x^2 + z^2}$$

The exact formulas for these quantities are:

$$U_z = -2G\sigma \left[ x \ln \frac{r_2}{r_1} + \pi t - (t+d)\theta_2 + d\theta_1 \right]$$

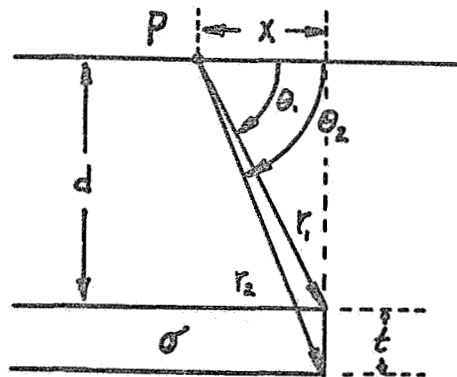

$$U_{zz} = -2G\sigma \left( \tan^{-1} \frac{x}{d} - \tan^{-1} \frac{x}{d+t} \right) = -2G\sigma (\theta_2 - \theta_1)$$

4. Vertical Cylinder: The following case is a good approximation for a position on the axis of a vertical cylinder.

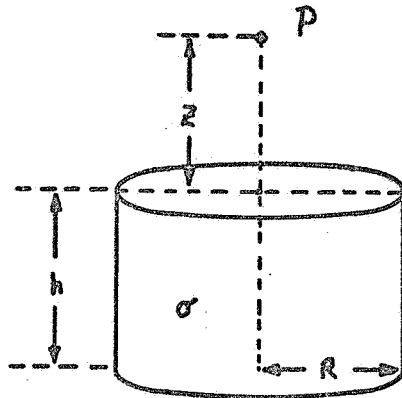

$\sigma$  = density contrast

$$U_z = -2\pi G\sigma \left[ h + (R^2 + z^2)^{1/2} - (R^2 + (h+z)^2)^{1/2} \right]$$

and

$$U_{zz} = -2\pi G\sigma \left[ \frac{z}{(R^2 + z^2)^{1/2}} - \frac{z(h+z)}{(R^2 + (h+z)^2)^{1/2}} \right]$$

## APPENDIX C

Gravity Gradient Derivation

The commonly used term "gravity gradient" is somewhat of a misnomer since "gradient" generally refers to a derivative, but a vector per se has no gradient. To clarify this situation, consider the gravitational potential,  $U$  at a point as a function of position, so that

$$U = U(x, y, z) .$$

The potential,  $U$  is a scalar function of position so that its first derivative of the potential is the gravitational field strength  $\bar{g}(x,y,z)$  vector or  $\bar{g} = -\nabla U$  whose components may be defined by

$$\begin{aligned} g(x) &= -\frac{\partial U}{\partial x} = -U_x \\ g(y) &= -\frac{\partial U}{\partial y} = -U_y \\ g(z) &= -\frac{\partial U}{\partial z} = -U_z \end{aligned}$$

The space rate of change of gravitation or the second derivative of the potential is  $\frac{d\bar{g}}{d\bar{R}}$  (where  $\bar{R}$  represents the position vector of a point in the field) which is a tensor function of position and is specified by nine components which may be written in matrix form as follows:

$$\frac{d\bar{g}}{d\bar{R}} = \begin{vmatrix} \frac{\partial g(x)}{\partial x} & \frac{\partial g(x)}{\partial y} & \frac{\partial g(x)}{\partial z} \\ \frac{\partial g(y)}{\partial x} & \frac{\partial g(y)}{\partial y} & \frac{\partial g(y)}{\partial z} \\ \frac{\partial g(z)}{\partial x} & \frac{\partial g(z)}{\partial y} & \frac{\partial g(z)}{\partial z} \end{vmatrix}$$

The above matrix components of the potential  $U$  which constitute the so-called "gravity gradient" can also be written as:

$$\frac{d\bar{g}}{d\bar{R}} = \begin{vmatrix} -U_{xx} & -U_{yx} & -U_{zx} \\ -U_{xy} & -U_{yy} & -U_{zy} \\ -U_{xz} & -U_{yz} & -U_{zz} \end{vmatrix}$$

Of these nine derivatives, only five are independent. It has been shown by Crowley, et al<sup>(1)</sup> that the Laplace equation which is valid for all points of the field not occupied by mass is specified

$$\nabla^2 U = U_{xx} + U_{yy} + U_{zz} = 0$$

Hence, of the principal diagonal terms, only two are independent. Crowley, et al,<sup>(1)</sup> also show that for any scalar function of position

$$\text{curl } (\nabla U) = 0$$

$$\text{curl } (\nabla U) = \hat{i} (U_{zy} - U_{yz}) + \hat{j} (U_{xz} - U_{zx}) + \hat{k} (U_{yx} - U_{xy})$$

so that

$$U_{xy} = U_{yx}$$

$$U_{yz} = U_{zy}$$

$$U_{zx} = U_{xz}$$

since each component of a zero vector must be equivalent to zero. From the above, it can be seen that the previous matrix is symmetric.

The principal diagonal terms of the matrix are longitudinal in nature and represent the rate of change of the gravity

- 
1. Crowley, J.C., Kolodkin, S.S. and Schneider, A.M., "Some Properties of the Gravitational Field and Their Possible Application to Space Navigation," Inst. Radio Eng. Trans. on Space, Electronics and Telemetry, Vol. 5 (March, 1959).

vector in the direction of the vector itself. The remaining terms of the matrix are cross-product or transverse quantities and represent the rate of change of the gravity vector in a direction perpendicular to the vector itself.

In the earlier days of geophysical exploration (torsion balance surveys), the term "gravity gradient" or "gradient" referred to the "horizontal gravity gradient" which in turn referred to the derivative of gravity in the x and/or y direction, namely  $U_{xz}$  and/or  $U_{yz}$ .  $U_{xz}$  was taken as the north derivative of gravity and  $U_{yz}$  was taken as the east derivative of gravity. The torsion balance provided measures of the cross-gradient terms  $U_{xz}$ ,  $U_{yz}$ , and  $2U_{xz}$  and the differential curvature expressed by  $(U_{yy} - U_{xx})$ .

For geophysical applications, the customary "vertical gravity gradient" term refers to the quantity  $U_{zz}$  of the matrix. For measurements on an orbiting spacecraft this is the preferred quantity to measure because it is the only one required, if it can be measured, and direct and simple interpretation methods can be applied.