

N70-15200
NASA CR-107622

NAMI-1090

OFF-VERTICAL ROTATION: A CONVENIENT PRECISE MEANS OF EXPOSING
THE PASSIVE HUMAN SUBJECT TO A ROTATING LINEAR ACCELERATION VECTOR

Ashton Graybiel and Earl F. Miller II

**CASE FILE
COPY**

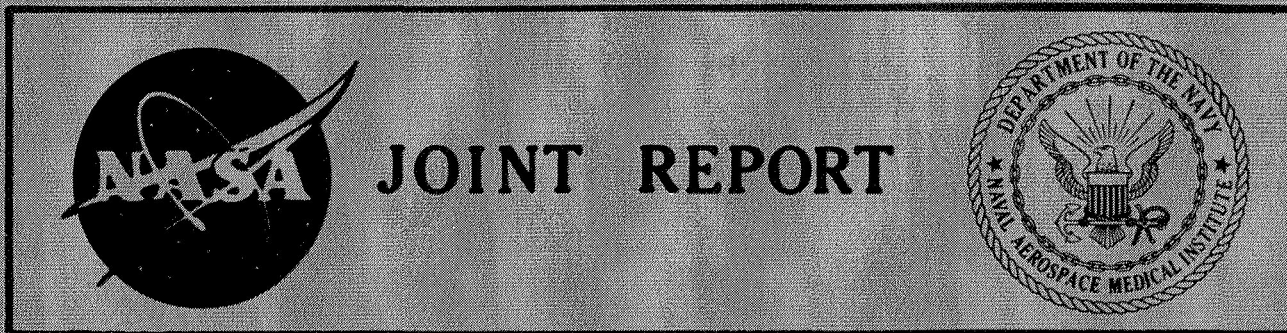

NAVAL AEROSPACE MEDICAL INSTITUTE
NATIONAL AERONAUTICS AND SPACE ADMINISTRATION

October 1969

This document has been approved for public release and sale; its distribution is unlimited.

This document has been approved for public release and sale;
its distribution is unlimited.

OFF-VERTICAL ROTATION: A CONVENIENT PRECISE MEANS OF EXPOSING
THE PASSIVE HUMAN SUBJECT TO A ROTATING LINEAR ACCELERATION VECTOR*

Ashton Graybiel and Earl F. Miller II

Bureau of Medicine and Surgery
MR005.01.01-0120B

NASA Order R-93

NASA Order T-81633

Released by

Captain M. D. Courtney, MC USN
Commanding Officer

17 October 1969

*This research was conducted under the sponsorship of the Office of Advanced Research and Technology, and the Biomedical Research Office, Manned Spacecraft Center, National Aeronautics and Space Administration.

NAVAL AEROSPACE MEDICAL INSTITUTE
NAVAL AEROSPACE MEDICAL CENTER
PENSACOLA, FLORIDA 32512

SUMMARY PAGE

THE PROBLEM

The study of disturbances of vestibular origin comprising the clinical picture of motion sickness and resulting from exposure to a rotating linear acceleration vector was carried out with a rotating chair modified to permit tilting up to 20° away from the upright. While rotating at constant velocity at a given angle of tilt, the subject was thus exposed to a continual change with reference to the gravitational upright. Stepwise increases in the level of stress were effected through automatic programming of the chair's angular velocity. Subjects were exposed until either they experienced mild motion sickness (the predetermined endpoint), or the cut-off point, a terminal velocity of 25 rpm at 10° tilt, was reached.

FINDINGS

Of the group of 100 healthy men, 88 reached the predetermined endpoint; all but 5 of the remainder reached it only when the angle of tilt was increased to 20° . Thus, the scores ranked 95 subjects in terms of their susceptibility to this unusual gravito-inertial force environment and demonstrated that 5 were highly insusceptible. The accuracy and flexibility of the method should prove it to be useful, not only as a provocative test of susceptibility to motion sickness but also a means of studying the symptomatology and underlying mechanisms.

INTRODUCTION

In a previous report (7) mention was made of a tilt chair device which, when rotating at constant velocity, exposed the subject to an unusual gravito-inertial force in the nature of a rotating linear acceleration vector (RLAV). The use of this type of stimulation has a brief history (2,3,6,9) which is notable for the discussion aroused as to whether the sensory receptors in the semicircular canals are stimulated in addition to those in the otolith organs. The fact that nystagmus is evoked at critical temporal and spatial patterns of stimulation implicates the canals by "association," although the mode of stimulation must be other than the manner in which the cupula-endolymph mechanism functions in response to angular or Coriolis accelerations. In view of the uncertainties regarding the possibility of canalicular stimulation, the combining term "vestibular" rather than otolithic stimulation will be used.

When a person is exposed to a RLAV, the disturbances of vestibular origin which are evoked fall into two main categories (4). One comprises reflex phenomena which constitute perturbations in or perversions of normal vestibular functions, e.g., inappropriate eye motions. The other comprises a wide variety of responses including the clinical picture of motion sickness with which this report is concerned.

PROCEDURE

SUBJECTS

One hundred volunteer male subjects 17 to 32 years of age participated. The majority, 58, were naval flight personnel, and all but three of the remainder were also in the Navy. All were healthy, and a medical evaluation revealed no significant defect, disorder, or disease. The sensory organs of the inner ear were evaluated with the aid of audiometry, ocular counterrolling, and the threshold oculogyral illusion (OGI) test.

Audiometric findings were within normal limits. The ocular counterrolling index (11), a test of otolith function, ranged from 133 to 573 minutes of arc; there were three values below 200, usually taken as the lower end of the normal range. The oculogyral illusion (OGI) test, described in detail elsewhere (5), required the subject to indicate rightward or leftward apparent movement of a dimly illuminated target while he was subjected to clockwise or counterclockwise angular accelerations. This procedure is a test of semicircular canal function, and the values obtained ranged from $< 0.113^\circ$ per sec^2 (the lowest obtainable with present equipment) to 0.821° per sec^2 . The upper normal threshold value is not firmly established; in any case, only five values were above 0.475° per sec^2 . Inasmuch as considerable practice is sometimes required before the lowest values are regularly obtained, the likelihood is that none was abnormal.

APPARTUS AND METHOD

A Stille rotating chair, model RS-3, was modified (Figure 1) for use as an off-vertical rotation (OVR) chair. It was mounted on a platform which could be tilted up to 20° either by a hand crank or by an electric motor, and the degree of tilt could be read from a large protractor. The subject's head was held rigidly against the headrest by adjustable straps across his forehead. The top of the subject's head could be centered precisely over the center of rotation, and smooth rotation was ensured by proper counterbalancing. The rotation was programmed on a time axis involving periods of acceleration at 0.5° per sec^2 for 30 seconds, followed by periods of constant velocity for 6 minutes until either the endpoint, described below, was reached or 6 minutes were completed at 25 rpm, the cut-off point. In effect, this program represented unit increases of 2.5 rpm every 6.5 minutes after the initial step. The endpoint could be expressed in terms of elapsed time at terminal velocity or as total elapsed time which served as an index of susceptibility to motion sickness.

With each revolution of the OVR device the subject continually changed position with respect to the gravitational upright. Thus, receptors in the paired maculae of utricle and saccule and nonvestibular proprioceptors were continually exposed to an unusual stimulus pattern. The uncertainty whether the semicircular canals also were stimulated by RLAV has been mentioned in the Introduction.

The subject was carefully instructed in the best manner of cooperating with the observer in estimating the endpoint termed "moderate Malaise A" (M II A) and scored by the diagnostic criteria previously described (8). The M II A level constitutes "very mild" motion sickness, and subjects may be exposed repeatedly without their complaining. Although overt symptoms soon disappear, a second trial was never undertaken the same day.

In conducting the tests, the subject's eyes were covered with a padded shield. The appraisal of the symptomatology was made during the run and recorded on a printed form (12). When the endpoint was reached, the chair was quickly tilted to the upright to abolish the stressful stimuli, and deceleration was accomplished at the same rate as acceleration.

RESULTS AND DISCUSSION

MOTION SICKNESS

During the period of exposure to the stressor, overt symptoms of motion sickness were usually absent or minimal until shortly before the endpoint was reached. Consequently, to avoid overshooting the endpoint, close attention was required on the part of subject and observer.

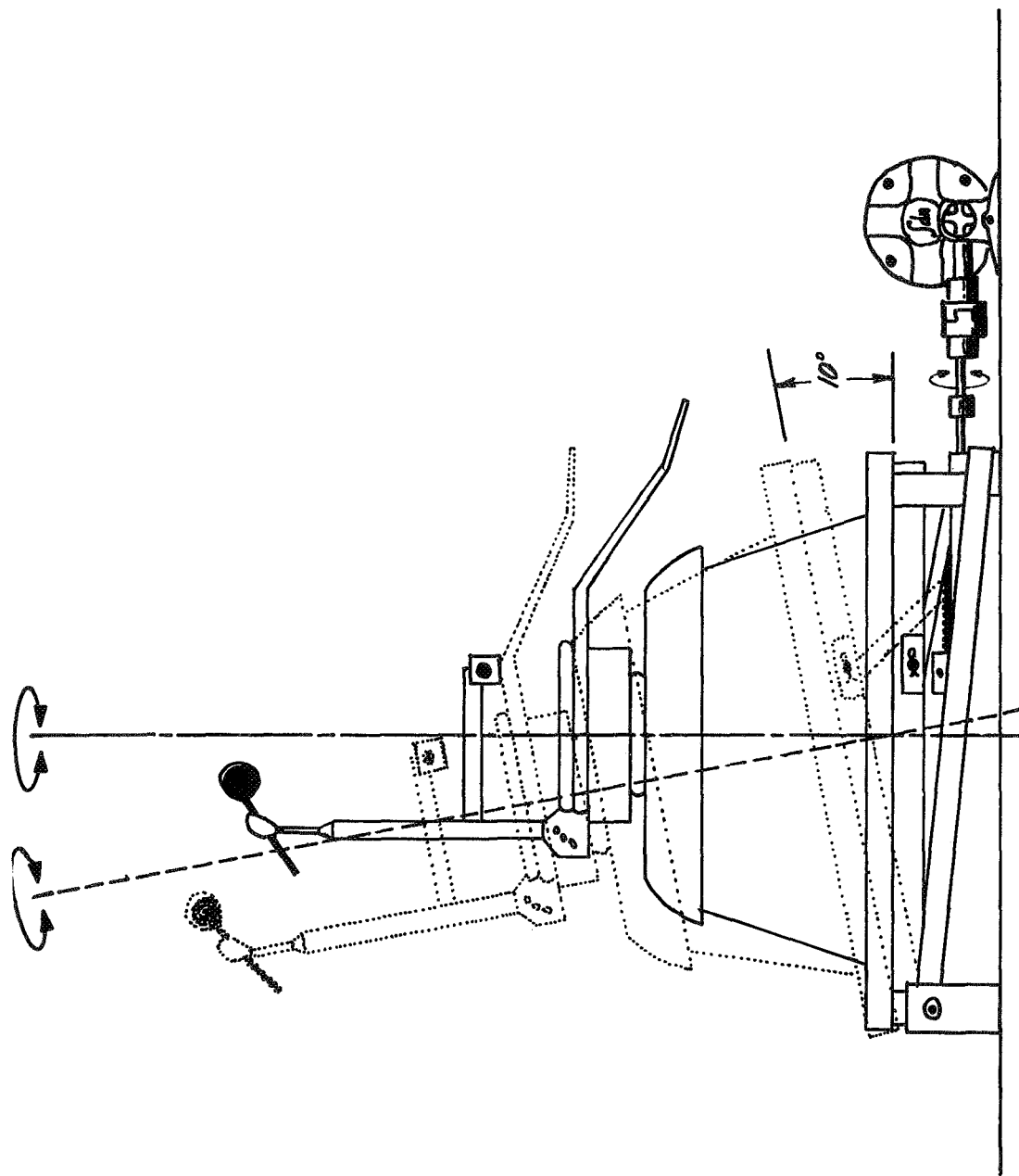

Figure 1

Off-vertical Rotating Chair Device
Slide mechanisms for positioning subject not shown.

In Figure 2 is shown the susceptibility index for 95 subjects; 88 reached the endpoint during the first run at 10° tilt, and 7 of the remaining 12 reached the endpoint in a second trial at 20° tilt (broken lines). The frequency distribution is heavily skewed in the positive direction, with the majority of subjects falling within the more "susceptible" half of the range.

Indubitably, adaptation was occurring during the entire period of rotation, and when symptoms appeared, they signalled that the adaptation was insufficient to prevent a failure in homeostatic adjustment, which led to the manifestation of motion sickness. Thus, especially when the exposure period was long, a significant but unknown amount of adaptation had taken place which might have accounted for the absence of symptoms, especially among those subjects who did not manifest symptoms until the angle of tilt was increased. This possibility is lent credence by the fact that, in another provocative test using a constant level of stimulation (Coriolis accelerations), very mild symptoms were evoked on occasion only to disappear with continuation of rotation (personal observations).

Figures 3 and 4 are plots comparing susceptibility to motion sickness with scores obtained in testing, respectively, the function of the semicircular canals and otolith organs. Although it appears that significant relationships were not found between functional test scores and susceptibility to motion sickness, it is worth adding that when extreme values are compared, susceptibility was higher in subjects with low rather than high OGI threshold test values, and susceptibility was lower in subjects with high rather than low values for the counterrolling index. Inasmuch as one would predict the contrary, these few extreme values support the conclusion that functional test scores within the normal range have no value in predicting susceptibility to motion sickness.

An unselected portion of the group (N = 38) were also ranked in their susceptibility to motion sickness using another provocative test (12) in which the subjects, while rotating at constant velocity in an upright Stille chair, were required to rotate their head out of the plane of passive rotation, thus generating Coriolis accelerations which stimulated the vestibular organs, notably, the semicircular canals. Although the programmed stimulus pattern was different in the two tests, and a common unit of stress was impossible to attain, the comparative rankings in Figure 5 are of interest. The majority of subjects demonstrated similar susceptibility in the two different gravitoinertial force environments whether their basic susceptibility was high or low. The minority, about 20 per cent, demonstrated striking differences in susceptibility, most likely attributable to differences in the accelerations to which they were exposed.

SENSATIONS DURING ROTATION

No attempt was made to obtain data on the complex pattern of "sensations" experienced by any of the 100 subjects during OVR. A few such observations had been made previously on other subjects (7). Normal subjects felt as if they were revolving, not rotating, and that the upper part of their body was continually, but to a variable degree, tilted away from the upright. Characteristically, except momentarily at onset,

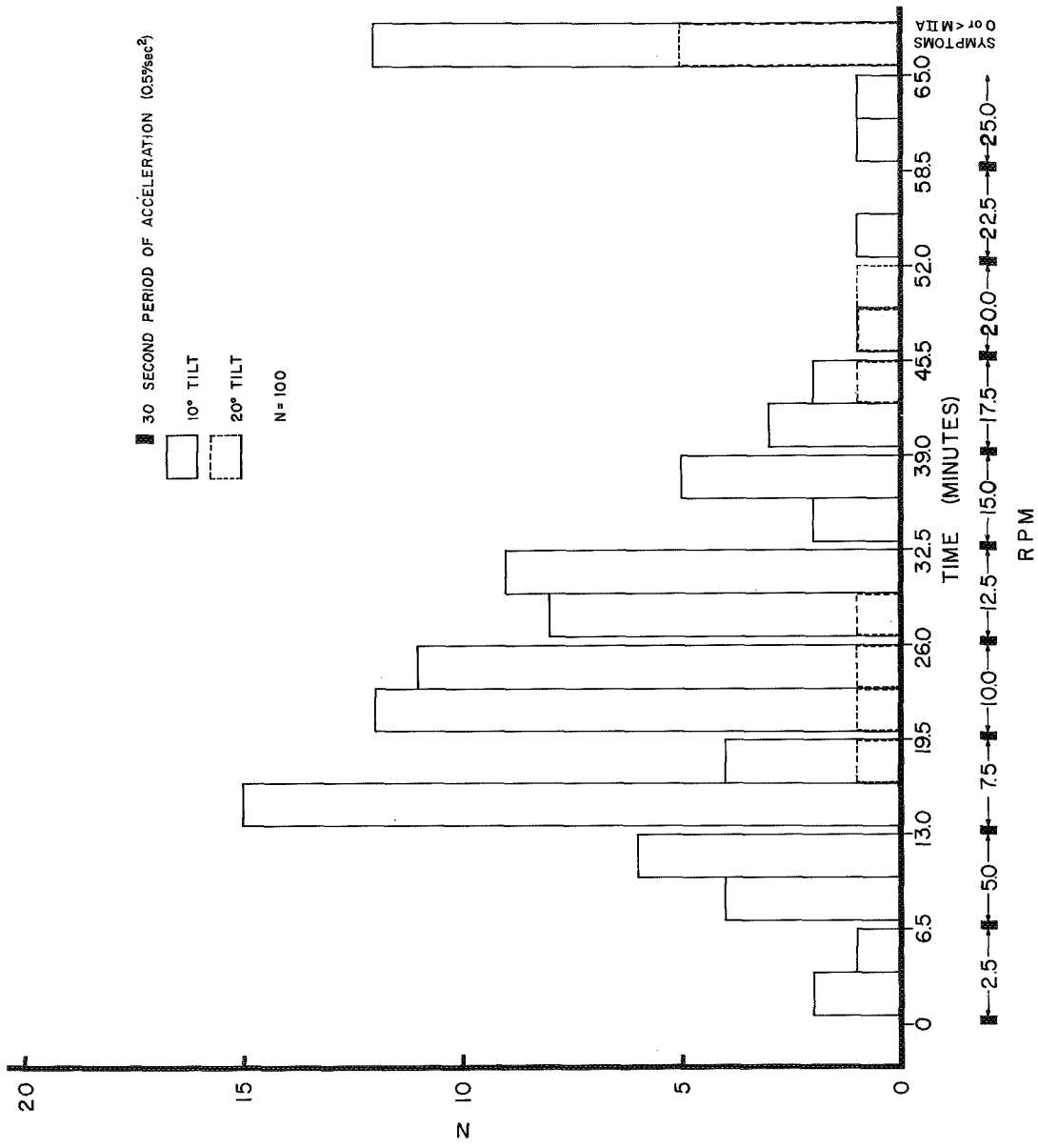

Figure 2

Susceptibility Index in Subjects Exposed to Off-vertical Rotation According to Programmed Stress Indicated on Abscissa. See text.

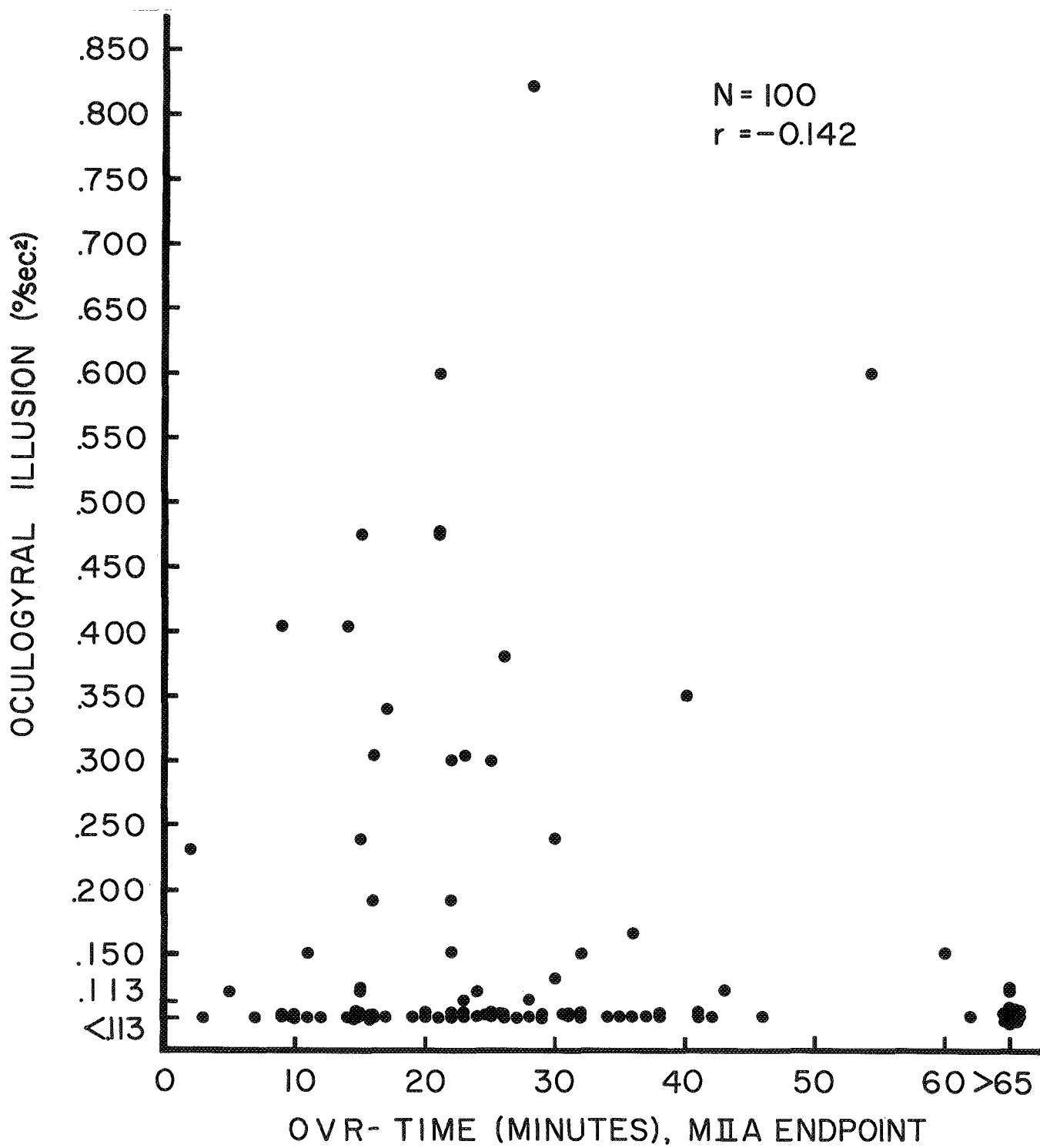

Figure 3
Comparison of Motion Sickness Susceptibility with Scores on Test of Semicircular Canal Function (the Oculogyral Illusion).

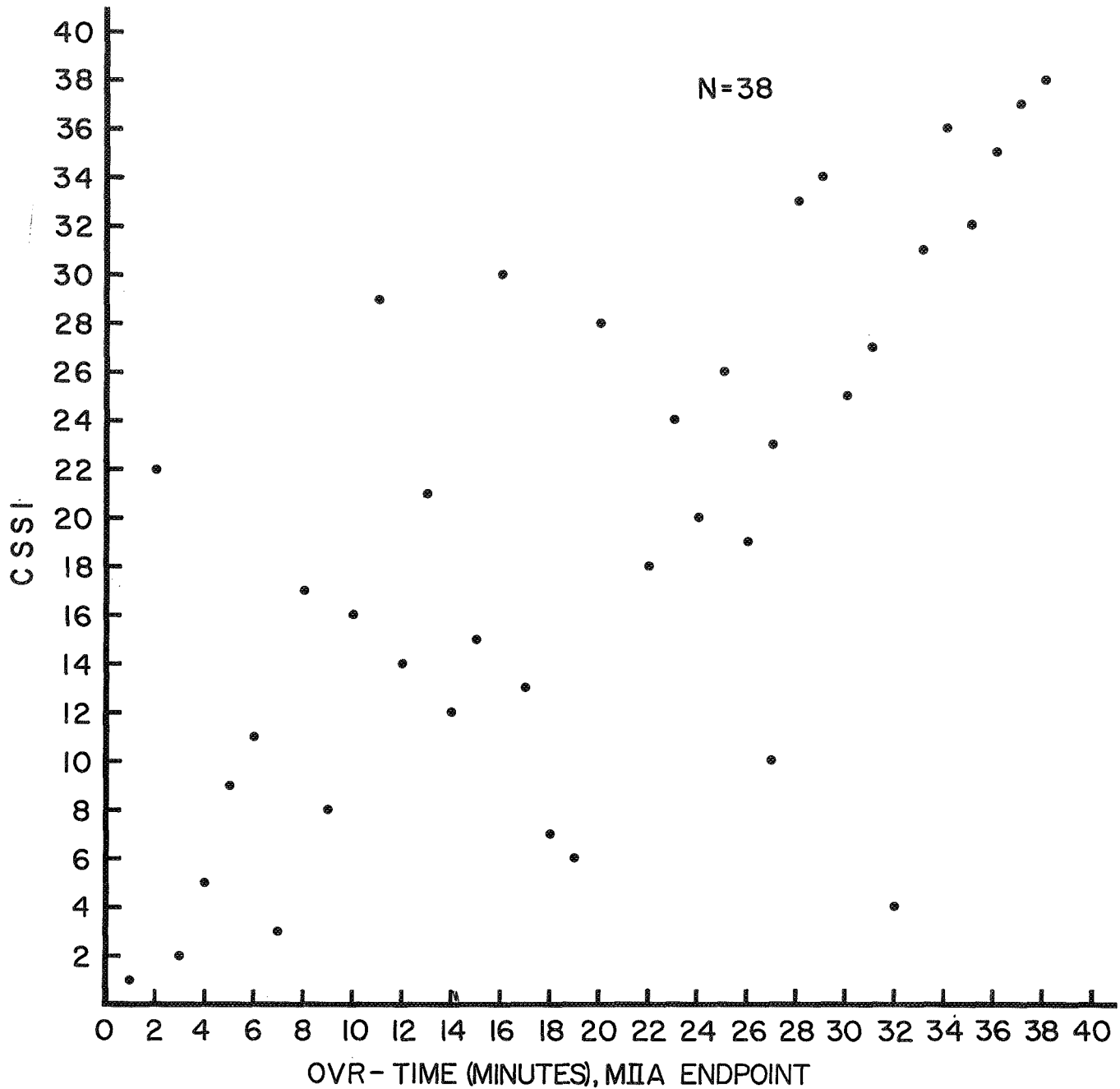

Figure 5

Comparative Ranking Among 38 of the 100 Subjects in Two Tests of Motion Sickness Susceptibility.

CSSI=^{Dispersed}Coriolis Susceptibility Index, a product of the average stressor effect of a single head movement by the number of head movements required to reach the predetermined endpoint (ref. 12).

they felt they were revolving in the direction opposite to that in which they were rotating. The differences between the normal and labyrinthine-defective subjects were mainly of a quantitative nature.

CONCLUSIONS

The OVR device, considered as a means of investigating the effects of "disturbing" the vestibular systems, has important advantages and some disadvantages. Its cardinal advantages include: 1) the effectiveness of this bizarre stimulus in evoking unusual responses; 2) the precision with which the stimulus can be controlled and manipulated; 3) the passive participation of the subject; and 4) the relatively low "cost" in terms of equipment, space, and technical skill. The disadvantages include: 1) uncertainty whether the semicircular canals as well as the otolith apparatus are stimulated; 2) limited direct accessibility to the subject during rotation; 3) the abnormal visual environment unless the subject's eyes are closed or covered; and 4) the impossibility of exposing more than one subject at a time.

From the practical standpoint, the OVR device is useful as a means of determining susceptibility to motion sickness using precise and reproducible stimulation. This permits individual ranking of subjects or placing them in graduated ranges of susceptibility. There is evidence that susceptibility to motion sickness may have value in predicting success in flight training (1), and the Soviet investigators (10) consider it to have value in predicting susceptibility to what we term aviator's vertigo. The method is a useful means of investigating the role of "secondary influences," including physiological and environmental variables and antimotion sickness drugs.

From the theoretical standpoint, the device has many uses in studying the symptomatology of motion sickness and such derived phenomena as individual differences, the time course of adaptation, and transfer of adaptation effects.

*

REFERENCES

1. Ambler, R. K., and Guedry, F. E., Jr., The validity of a brief vestibular dis-orientation test in screening pilot trainees. Aerospace Med., 37:124-126, 1966.
2. Benson, A. J., and Bodin, M. A., Interaction of linear and angular accelerations on vestibular receptors in man. Aerospace Med., 37:144-154, 1966.
3. Correia, M. J., and Guedry, F. E., Jr., Modification of vestibular responses as a function of rate of rotation about an Earth-horizontal axis. Acta otolaryng., Stockh., 62:297-308, 1967.
4. Graybiel, A., Structural elements in the concept of motion sickness. Aerospace Med., 40:351-367, 1969.
5. Graybiel, A., and Hupp, D. I., The oculogyral illusion: A form of apparent motion which may be observed following stimulation of the semicircular canals. J. aviat. Med., 17:3-27, 1946.
6. Graybiel, A., and Johnson, W. H., A comparison of the symptomatology experienced by healthy persons and subjects with loss of labyrinthine function when exposed to unusual patterns of centripetal force in a counterrotating room. Ann. Otol., 72:357-373, 1963.
7. Graybiel, A., and Miller, E. F. II, The otolith organs as a primary etiological factor in motion sickness: With a note on "off-vertical" rotation. In: Fourth Symposium on the Role of the Vestibular Organs in Space Exploration. NASA Special Publication. Washington, D. C.: U. S. Government Printing Office. In press.
8. Graybiel, A., Wood, C. D., Miller, E. F. II, and Cramer, D. B., Diagnostic criteria for grading the severity of acute motion sickness. Aerospace Med., 39:453-455, 1968.
9. Guedry, F. E., Jr., Orientation of the rotation-axis relative to gravity: Its influence on nystagmus and the sensation of rotation. Acta otolaryng., Stockh., 60:30-48, 1964.
10. Khilov, K. L., Function of the vestibular analyzer in space flights. Arch. Otolaryng., 90:152-160, 1969.
11. Miller, E. F. II, Counterrolling of the human eyes produced by head tilt with respect to gravity. Acta otolaryng., Stockh., 54:479-501, 1961.
12. Miller, E. F. II, and Graybiel, A., A simple laboratory means of determining the index of susceptibility to Coriolis (motion) sickness. NAMI-1058. NASA Order Nos. T81633 and R-93. Pensacola, Fla.: Naval Aerospace Medical Institute, 1969.

Unclassified

Security Classification

DOCUMENT CONTROL DATA - R & D		
<i>(Security classification of title, body of abstract and indexing annotation must be entered when the overall report is classified)</i>		
1. ORIGINATING ACTIVITY (Corporate author) Naval Aerospace Medical Institute Pensacola, Florida 32512		2a. REPORT SECURITY CLASSIFICATION Unclassified
		2b. GROUP N/A
3. REPORT TITLE OFF-VERTICAL ROTATION: A CONVENIENT PRECISE MEANS OF EXPOSING THE PASSIVE HUMAN SUBJECT TO A ROTATING LINEAR ACCELERATION VECTOR		
4. DESCRIPTIVE NOTES (Type of report and inclusive dates)		
5. AUTHOR(S) (First name, middle initial, last name) Ashton Graybiel and Earl F. Miller II		
6. REPORT DATE 17 October 1969	7a. TOTAL NO. OF PAGES 11	7b. NO. OF REFS 12
8a. CONTRACT OR GRANT NO. NASA R-93 and NASA T-81633	9a. ORIGINATOR'S REPORT NUMBER(S) NAMI-1090	
b. PROJECT NO. BuMed MR005.01.01-0120B	9b. OTHER REPORT NO(S) (Any other numbers that may be assigned this report) 1	
c.		
d.		
10. DISTRIBUTION STATEMENT This document has been approved for public release and sale; its distribution is unlimited.		
11. SUPPLEMENTARY NOTES		12. SPONSORING MILITARY ACTIVITY
13. ABSTRACT <p>A rotating chair modified to permit tilting of a subject up to 20° from the upright was used to expose 100 normal men to an unusual vestibular stimulus, eliciting manifestations including the clinical picture of motion sickness. Through stepwise increases in angular velocity of the chair, subjects were rotated at 10° tilt until they experienced mild motion sickness (a predetermined endpoint) or until a terminal velocity of 25 rpm was reached. Eighty-eight men reached the predetermined endpoint; seven additional men reached it only when the tilt angle was increased to 20°; the remaining five men were shown to be highly insusceptible. The accuracy and flexibility of the method should prove to be useful in ranking persons according to their susceptibility to motion sickness and in studying the symptomatology, including the underlying central nervous system mechanisms.</p>		

Unclassified

Security Classification

14. KEY WORDS	LINK A		LINK B		LINK C	
	ROLE	WT	ROLE	WT	ROLE	WT
Motion sickness susceptibility						
Vestibular apparatus disturbances						
Vestibular apparatus tests						
Stress						
Acceleration stress						
Gravitation effects						