

N 70 28 28

CR-102648



Contract Number NAS8-21151 1968 August 28

FOREWORD

REVIEW

EXPERIMENTAL

STUDY OF
TECHNIQUES
FOR THE REDUCTION OF CREEP
IN PLATED WIRE MEMORIES
FINAL REPORT

CASE FILE
COPY

Honeywell

AEROSPACE DIVISION
ST. PETERSBURG, FLORIDA

Contract Number NAS8-21151

1968 August 28

STUDY OF
TECHNIQUES
FOR THE REDUCTION OF CREEP
IN PLATED WIRE MEMORIES
FINAL REPORT

Prepared for: George C. Marshall Space Flight Center
Huntsville, Alabama

Prepared by: M. E. Petersen / for
W. A. England
Technical Director

M. E. Petersen
M. E. Petersen
Project Engineer

Approved: B. B. Winterbottom / for
A. W. Sullivan
Chief Engineer
Computer Group

Honeywell

AEROSPACE DIVISION
ST. PETERSBURG, FLORIDA

TABLE OF CONTENTS

	<u>Page</u>
List of Illustrations	iii
 <u>Section</u>	
1 FOREWORD	1-1
2 REVIEW OF OBJECTIVES	2-1
3 EXPERIMENTAL PROGRAM	3-1
3.1 Introduction	3-1
3.2 Experimental Approach	3-7
3.3 Memory System Considerations	3-28
4 CONCLUSIONS	4-1
5 SUGGESTIONS FOR FURTHER WORK	5-1
 <u>Appendix</u>	
A WIRE PLATING AND TESTING	A-1
B TUNNEL STRUCTURE FABRICATION	B-1

LIST OF ILLUSTRATIONS

<u>Figure</u>	<u>Title</u>	<u>Page</u>
3-1	Stoner-Wohlfarth Astroid	3-2
3-2	Discrete Bands of Film	3-3
3-3	Cylindrical Thin Film Storage Element	3-5
3-4	Demagnetization Versus Bit Length	3-6
3-5	Flash Heating Fixture	3-8
3-6	Photo-Etch Mask Holding Fixture	3-9
3-7	Photo-Etched Plated Wires	3-11
3-8	Outputs From Etched Wires	3-12
3-9	Zero Point Versus Bit Length	3-13
3-10	Operating Points For 2 Mil Wire - 2μ Ni-Fe Film	3-17
3-11	Operating Points For 2 Mil Plated Wire	3-19
3-12	Adjacent Bit Interference Versus Spacing	3-19
3-13	Word Strap Test Patterns - 10, 15, and 20 Mil Centers	3-21
3-14	Cross Section of Plated Wire Test Fixture	3-22
3-15	Plated Wire Operating Points	3-23
3-16	Plated Wire Test Fixture For Reduced Diameter Wires	3-24
3-17	Two-Turn Test Fixture For Testing 0.5 Mil Wire	3-26
3-18	Drive and Output Waveforms	3-27

21151-FR

Section 1

FOREWORD

This is the final report for work performed under Contract Number NAS-8-21151 covering the period beginning 1967 June 28 and ending 1968 August 28.

Section 2

REVIEW OF OBJECTIVES

The objective of this contract was the modification of the geometry of the 5 mil diameter plated wire (which had recently been developed) to reduce creep and drive requirements.

The goal of this effort was the development of a new memory element permitting design of a memory system with the following criteria:

High density with bits on ten mil centers.

Word currents of 100 milliamperes.

No bipolar digit currents.

Useful lifetime of five years at 85°C.

Cycle time of one microsecond or less for a 10^6 word memory.

System cost of one cent per bit or less.

System power less than 10 watts.

Section 3

EXPERIMENTAL PROGRAM

3.1 INTRODUCTION

Development of plated wire memory elements has been underway for about ten years. When this program began the major development was centered on films one micron thick which were plated on wire 5 mils in diameter. Considerable analytical work on this memory element had been done.

Magnetization reversal in planar or closed flux path thin films having uniaxial anisotropy had been described⁽¹⁾ in terms of the orthogonal fields necessary to produce switching.

The astroid-shape curve describing this reversal is shown in Figure 3-1. The hard axis in our case is the axial direction, while the easy axis is the circumferential direction. Generally, the curve indicates that if the magnetization vector lies inside the astroid, reversible change of magnetization occurs; while if it is outside the astroid, destructive readout occurs. The wall motion critical curve is shown with the maximum value equal to the coercivity H_c . This is the field required for reversal of magnetization along the easy axis.

Writing into the element is performed by the coincident application of an axial and circumferential field. The magnitude of the axial field may exceed the anisotropy field, but the circumferential field must obviously be less than the coercivity. For readout, only the axial field is used. If the field is in excess of the anisotropy a destructive readout occurs; if the field is less than the anisotropy, a nondestructive readout results. It has been found in practice that the magnetization can be disturbed by combinations of fields in the circumferential and axial directions having amplitudes whose vector sum is within the astroid. This type of change in magnetization has been designated as creep. That is, word and unipolar bit write fields when applied respectively to the same addressed bit, will gradually produce disturbance on the adjacent bits (ABI), even though the disturbing fields are within the critical threshold for static fields. Thus,

(1) E. C. Stoner and E. P. Wohlfarth, Philadelphia Transactions Royal Society, A 294, 599, 1948.

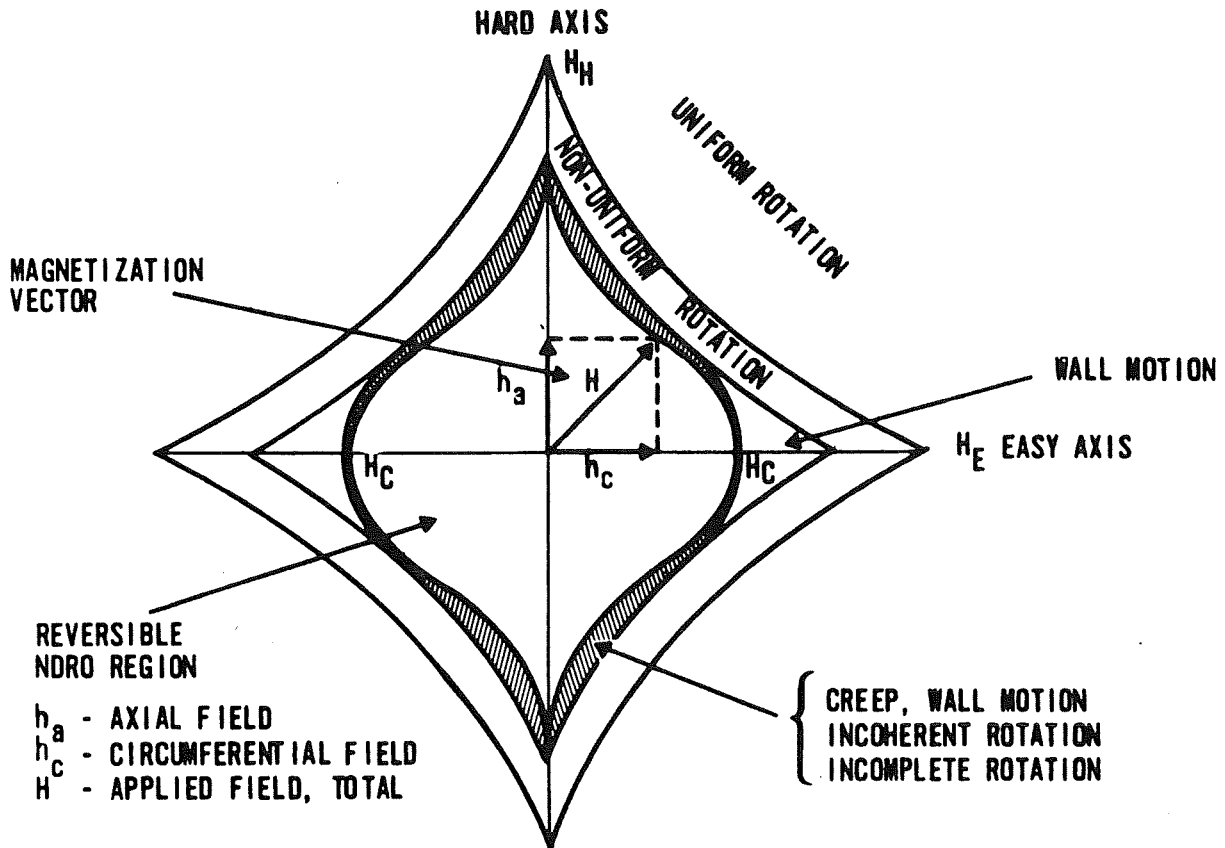

FIGURE 3-1. STONER-WOHLFARTH ASTROID

creep reduces the effective working area within the astroid and therefore can impose severe restrictions on the operating currents.

It has been shown that creep is associated with bit packing density (since it is produced by fields associated with currents along adjacent word lines), effect of stray word currents on the bit in question, and external unwanted fields. The first obvious approach to reduce creep is to remove the ferromagnetic material between bits, so that each bit is both physically and electrically discrete. That is, to have discrete bands of a magnetic film separated by a nonferromagnetic material as shown in Figure 3-2.

0367-649A

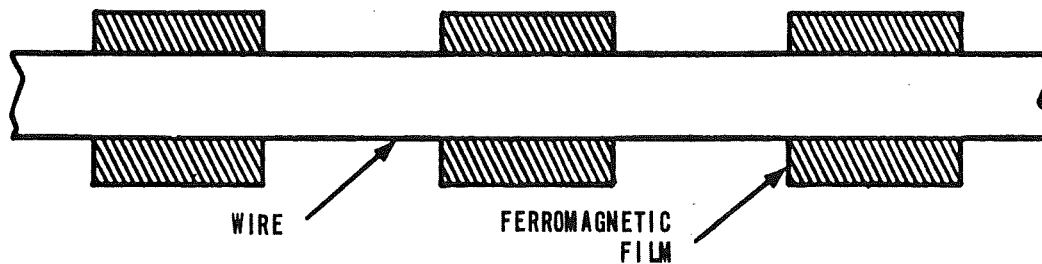

FIGURE 3-2. DISCRETE BANDS OF FILM

While discrete bands will minimize creep, they do introduce disadvantages other than those involved in fabrication. The principal difficulty arises from the shape anisotropy which introduces a demagnetization term which increases greatly as the bit length is shortened.

In an uniaxial, cylindrical thin ferromagnetic film (as is approached by a one micron thick film on a five mil wire substrate) the hard direction is considered along the axis of the wire, and the easy direction is circumferential. The switching behavior of the film is analogous to that of planar films and, in general, the simple Stoner-Wohlfarth model seems to apply. In the circumferential, closed-flux path direction the magnetization path is closed and reversal of magnetization can take place without the formation of free poles. However, in the axial direction magnetization reversal leads to the formation of free poles which results in a demagnetizing field.

As the magnetization vector (Figure 3-3A) in the easy, circumferential direction (M_c) is reversed in an element, it will rotate into the axial direction. This rotation will create poles at the ends of the element producing a demagnetizing field. The demagnetizing field, since it is only in the axial direction, effectively adds an anisotropy term to that already existing. The total anisotropy, H_k , is the sum of the original anisotropy (H_k) and the demagnetization (H_D):

$$H'_k = H_k + H_D \quad (3-1)$$

Analytical methods for calculating the magnitude and extent of the demagnetizing field have been developed^(2, 3). The demagnetization (H_D) may be expressed⁽²⁾ in the form of

$$H_D = \frac{\delta M}{b} - \left[D(Z/a, b/a) \right] \quad (3-2)$$

The terms are defined in Figure 3-3B. In Equation 3-2, $D(Z/a, b/a)$ can be expressed and evaluated in the form of an elliptical function. For a one micron thick 80/20 permalloy film on a 5 mil diameter wire, the demagnetizing field will vary with bit length as shown in Figure 3-4.

For a typical film having an H_k of about 3 oersteds, the demagnetizing field contribution to the anisotropy for a bit length of 50 mil, is already about 0.5 oersted. For decreasing bit lengths, the demagnetizing field increases exponentially. For high packing densities, bit lengths of about 5 mils are desirable, thus a reduction in wire diameter for these high packing densities is required.

(2) T. H. O'Dell, The Magnetic Excitation Inside a Cylindrical Thin Film Ferromagnetic, Monograph 396M, IEE, 1960.

(3) H. J. Kump and T. G. Greene, Magnetization of the Universal Cylindrical Thin Films, I. B. M. Journal, 130, 1963.

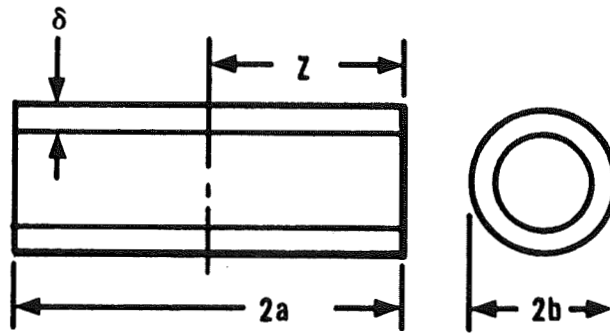
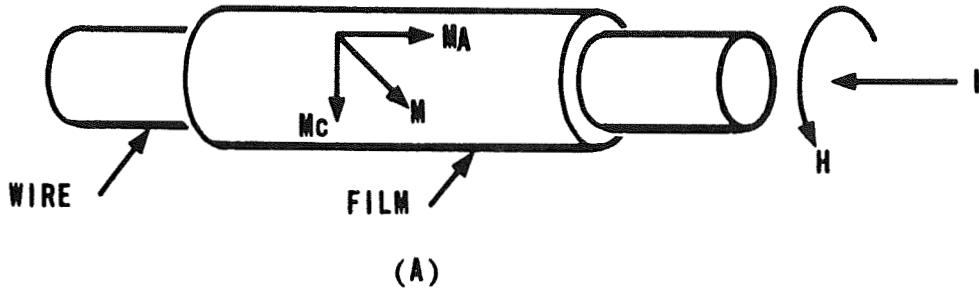

(B)

δ : FILM THICKNESS
 $2a$: LENGTH OF WIRE
 $2b$: DIAMETER OF WIRE

FIGURE 3-3. CYLINDRICAL THIN FILM STORAGE ELEMENT

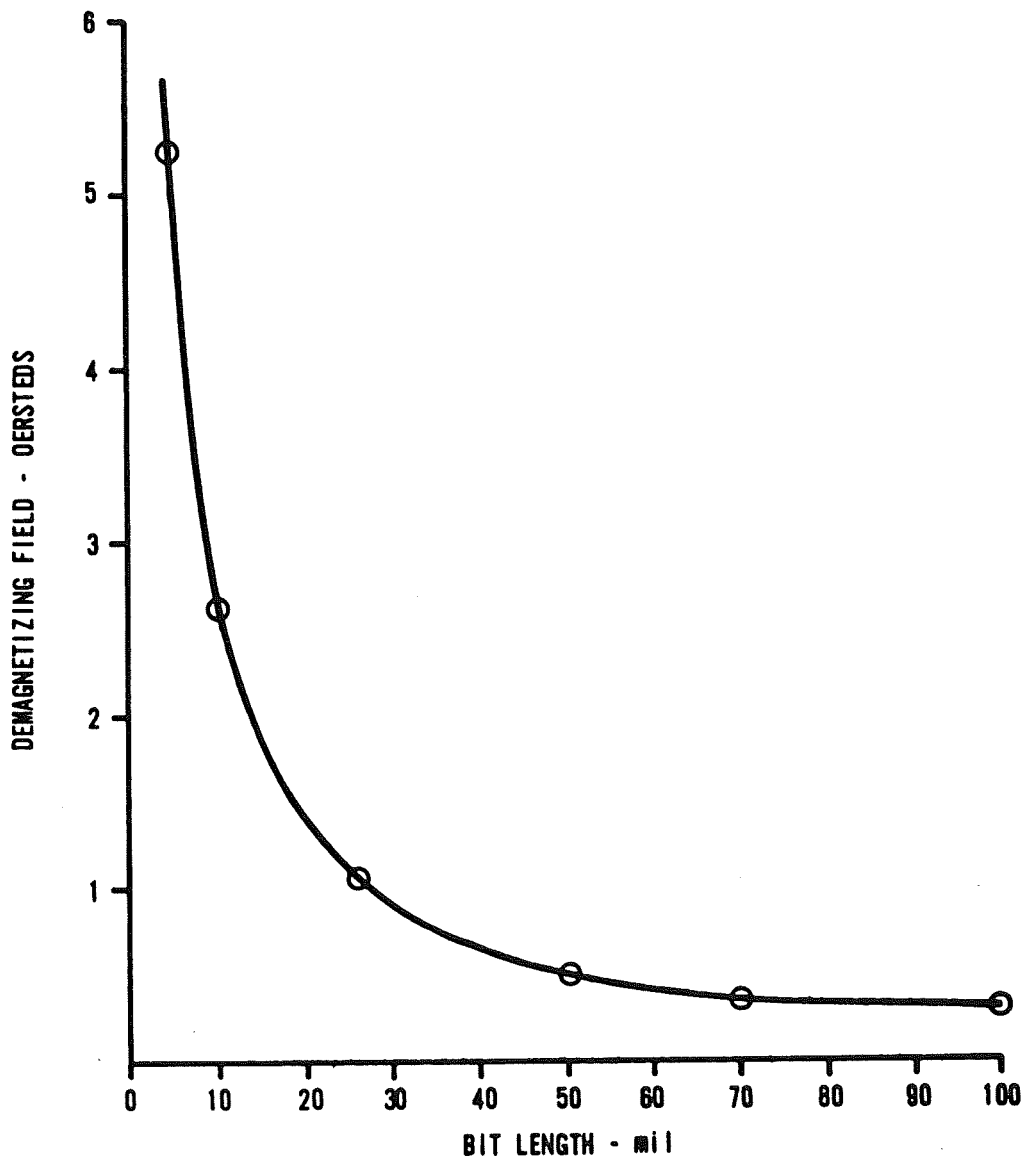

FIGURE 3-4. DEMAGNETIZATION VERSUS BIT LENGTH

3.2 EXPERIMENTAL APPROACH

The analytical work done on plated wire memory elements indicated two possibilities:

The bits could be made shorter without getting an excessive demagnetizing field during read and write operations. Figure 3-4 shows that the bit density could be raised to 40 bits per inch before the demagnetizing field reaches one oersted near the end of the bit.

Using discrete bits instead of a continuous plated film would eliminate the possibility of domain wall movement from bit to bit and possibly permit higher packing densities.

Thus it appeared that higher packing density might be possible on 5 mil wire. The first approach to creating discrete bits was use of a fixture permitting flash heating of short sections of the permalloy film. The fixture used is shown in Figure 3-5. Basically, it consists of two mercury contacts separated by a thin dielectric pierced by a small hole. In operation, a plated wire is passed through the hole to connect the two mercury contacts. A pulse of current is then used to heat the short section of wire completing the circuit from contact to contact.

Operation of the device depends on the altering of magnetic characteristics of the film at the high temperature produced by the current pulse. Grain growth, recrystallization and diffusion rapidly modify the magnetic characteristics of the heated material.

This technique was tested with 5 mil wire and produced excellent bit isolation when the correct heating cycle was used. The problems with this method were:

The optimum duration of the current pulse was two seconds-- too long for any practical production application. Shorter pulses at higher power levels heated the BeCu substrate excessively, resulting in deformation of the wire.

Minor variations in the wire surface caused larger variations in the optimum heat cycle.

While these problems were not insoluble, the probable cost of developing this technique led to the use of the photo-etch process developed by Mo.⁽⁴⁾ A mask and mask holding fixture (see Figure 3-6) were designed and

(4) R.S.Y. Mo., Doctoral Thesis, Electrical Engineering Department, Northeastern University, 1967

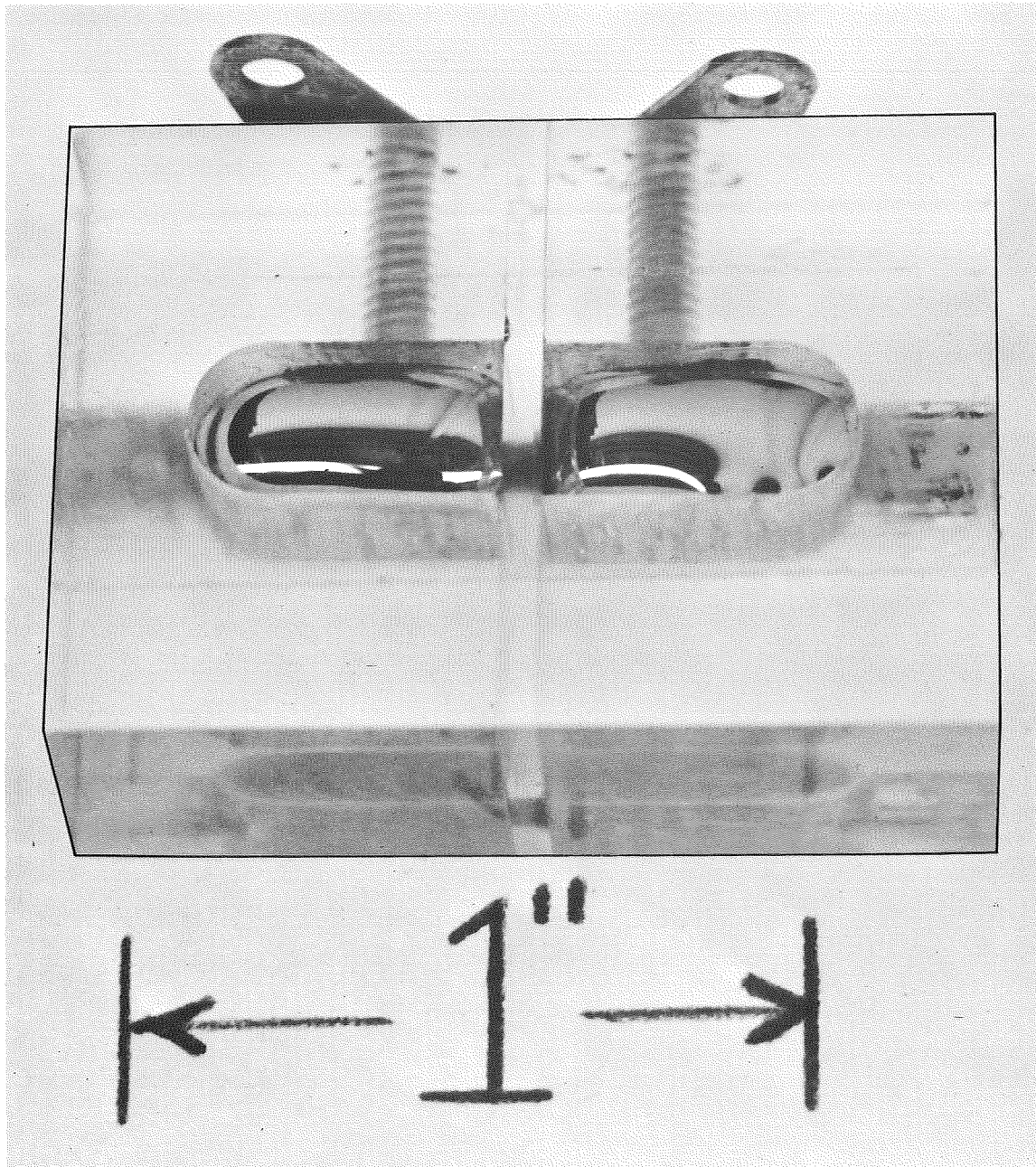

FIGURE 3-5. FLASH HEATING FIXTURE

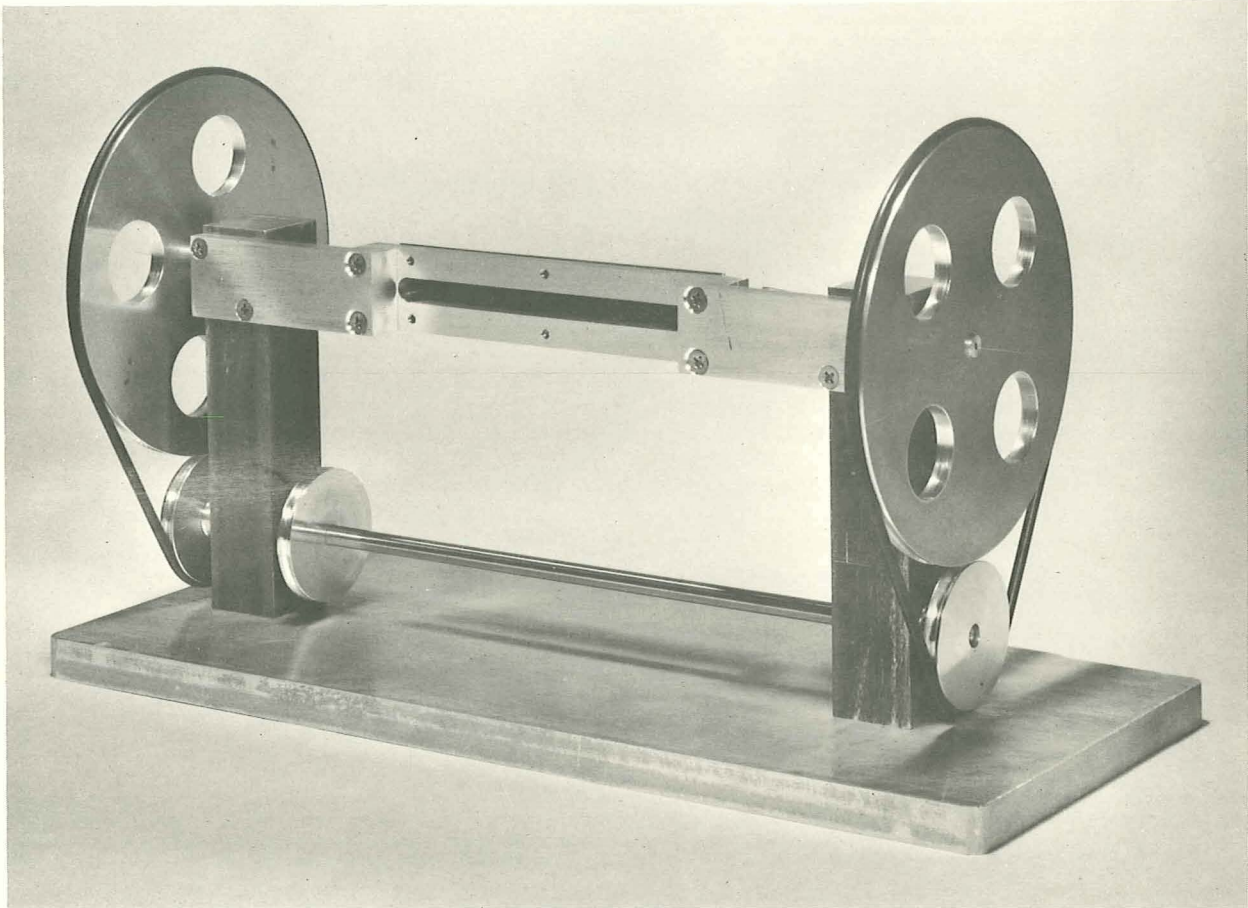

FIGURE 3-6. PHOTO-ETCH MASK HOLDING FIXTURE

fabricated. In operation, the photosensitized wire is held by the clamps and rotated in front of a series of apertures spaced 10, 20, and 40 mils apart in the photographic mask. Using this fixture, bits on 5 mil diameter wire were isolated on 10, 20, and 40 mil centers as shown in Figure 3-7. The area of maximum reflection is the NiFe plating. These bits were then scanned with a test program of 10^4 history, 1 write and read with a word current, I_w , of 940 milliamperes and a digit current, I_D , of 40 milliamperes by pulling the wire through a test fixture consisting of a tunnel structure with 5 mil wide single turn, unkeepered word straps. Outputs are shown in Figure 3-8. Each cycle of the output represents the readout signal of a single bit as it was moved past the word strap.

Several interesting effects were noted:

The amplitude of the readout signal dropped to a lower level between bits for the bits on 20 and 40 mil centers than for the bits on 10 mil centers. This is probably due to the greater isolation distances shown in Figure 3-1.

The peak amplitudes for 20 and 40 mil bits are higher than the peak amplitude for the 10 mil bit. This is most likely due to the greater effective bit length. The non-zero output for etched areas indicated the effective bit length was greater than 5 mils, since the word strap was reading film not covered by the 5 mil wide strap.

A modulation of the output of the 40 mil bits exists. The cause of this variation was not isolated.

The bits were then subjected to the "zero point" test where the minimum word current, applied simultaneously with a standard digit current, required to reverse 50 percent of previously stored flux is measured. This test gives a measure of the demagnetizing field of the bit since shorter bits with higher demagnetizing fields will require higher word current to switch. Results of the test are shown in Figure 3-9.

While the demagnetizing field is evidently rising as the bit length is reduced, the rise is not as rapid as expected. This indicates the physically isolated bit is being magnetically coupled.

Work by Mo.⁽⁴⁾ had indicated that the coupling by an internal field in the film could be reduced by use of a keeper over the word straps. Perm-alloy keepers were installed over the word straps in the test fixture. These keepers reduced word current requirements from 940 milliamperes to 650 milliamperes for standard 5 mil wire.

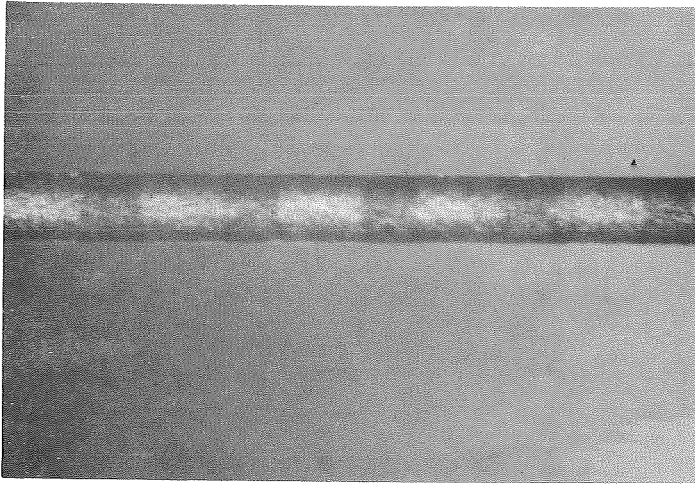

a. Bits on 10 mil centers

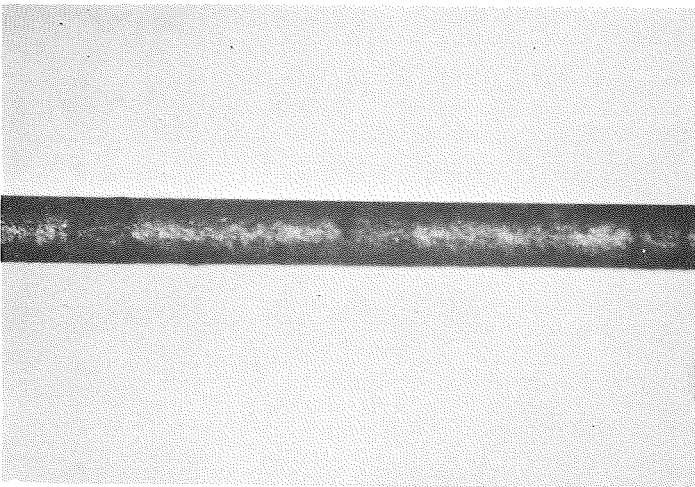

b. Bits on 20 mil centers

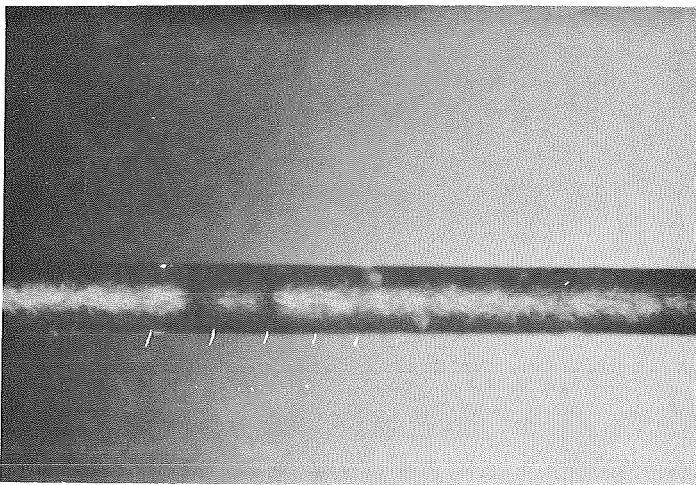

c. Bits on 40 mil centers

FIGURE 3-7. PHOTO-ETCHED PLATED WIRES

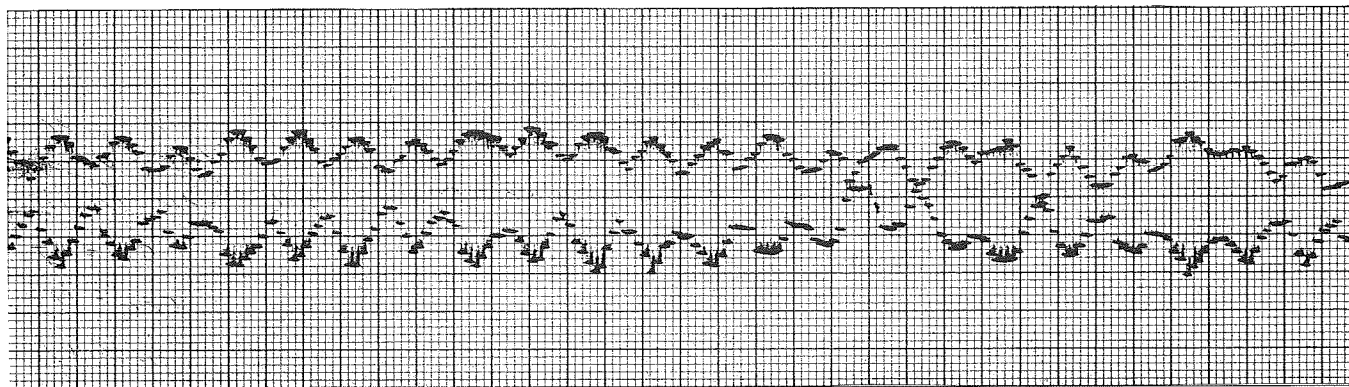

a. Bits on 10 mil centers

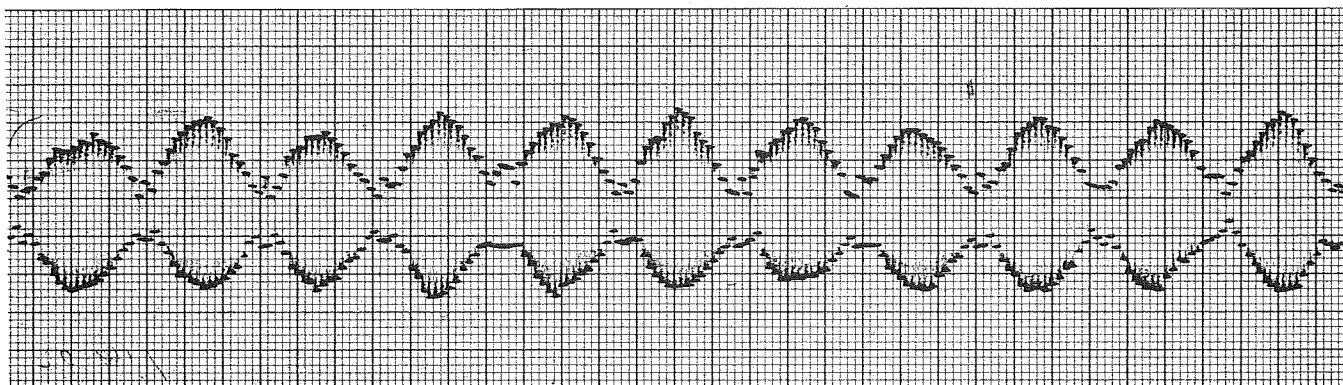

b. Bits on 20 mil centers

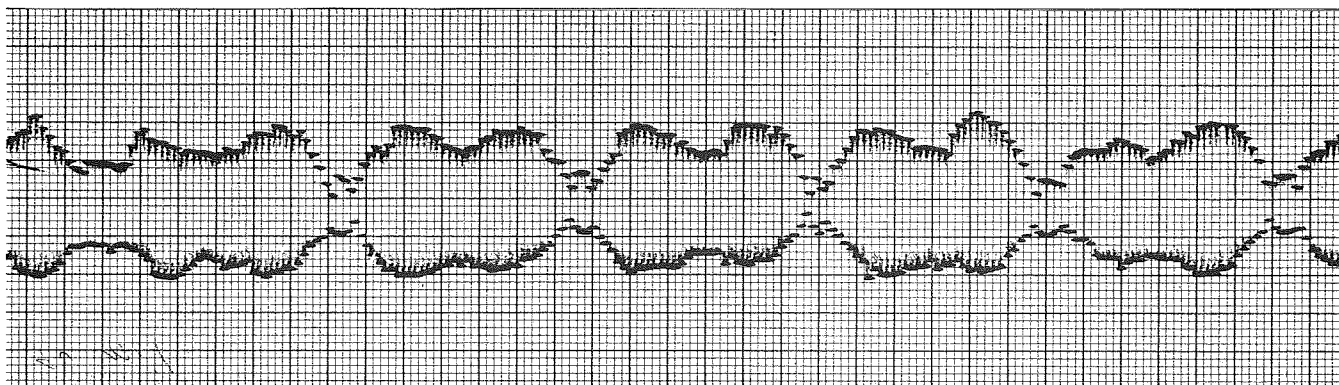

c. Bits on 40 mil centers

FIGURE 3-8. OUTPUTS FROM ETCHED WIRES

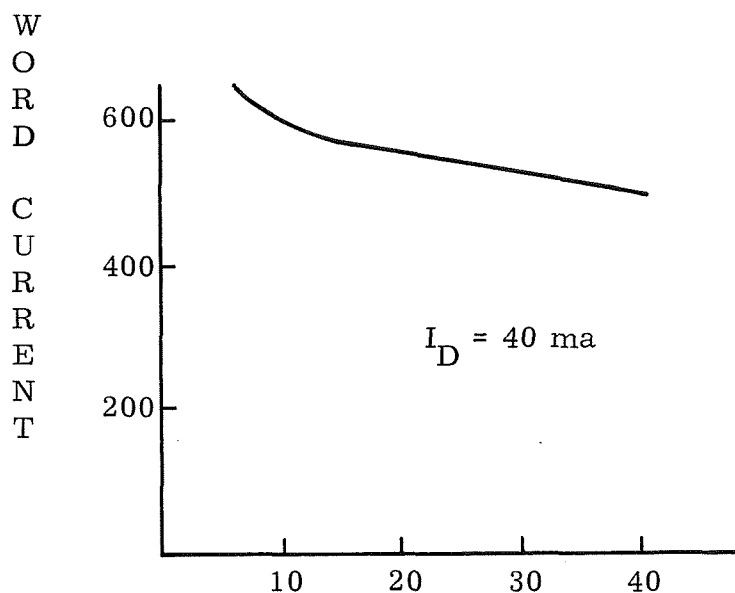

FIGURE 3-9. ZERO POINT VERSUS BIT LENGTH

Testing of isolated bits on 10, 20, and 40 mil centers was then started. Reference data on a standard 5 mil wire was first collected using word straps on 20 mil centers. This wire was subjected to several programs consisting of the following:

Program A - Read Disturb

10^4 x history, 1 x write, 10^4 x read.

Program B - Digit Disturb

10^4 x history, 1 x write, 10^4 x digit disturb, 10^4 x read.

Program C - Left Interleaved Disturb

10^4 x history, 1 x write, 10^4 x (write left, read), 10^4 x read.

Program D - Right Interleaved Disturb

10^4 x history, 1 x write, 10^4 (read, write right), 10^4 x read.

Program E - Full Interleaved Disturb

10^4 x history, 1 x write, 10^4 x (write left, read, write right),
 10^4 x read.

Program F - Left Burst Disturb

10^4 x history, 1 x write, 10^4 x write left, 10^4 x read.

Program G - Right Burst Disturb

10^4 x history, 1 x write, 10^4 x write right, 10^4 x read.

Program H - Full Burst Disturb

10^4 x history, 1 x write, 10^4 x write left, 10^4 x read, 10^4 x write
right, 10^4 x read.

Word and digit currents for all programs were 650 and 40 milliamperes,
respectively. Outputs are as shown in Table 3-1.

TABLE 3-1. PULSE OUTPUTS OF 5 MIL WIRE AFTER DISTURBING

Program	Output	
	0	1
A	-10.5 mv	+9.0 mv
B	-10.5 mv	+9.0 mv
C	- 3.0 mv	+4.5 mv
D	- 1.0 mv	+5.0 mv
E	+ 9.0 mv	-1.0 mv
F	- 1.5 mv	-4.0 mv
G	- 1.0 mv	+6.0 mv
H	+ 4.0 mv	+1.0 mv

Except for a small amount of skew, "0" and "1" outputs are symmetrical. It can be seen that creep severely affected the stored information in all test programs using word current in adjacent straps. In Programs E and H, creep reversed the polarity of the center bit.

To get a more quantitative measure of this effect, Programs C and D were repeated using adjacent word current sufficient enough to reduce the output by 50 percent. The results of this test are shown in Table 3-2.

TABLE 3-2. MAXIMUM WORD CURRENTS
FOR 50 PERCENT DISTURBANCE

	Disturb Current	
	Left	Right
Bit 1	400 ma	500 ma
Bit 2	400 ma	450 ma

The results of this test agree very well with the original Programs C and D test results. The tests were then repeated with bits on 20 mil centers isolated by etching as shown in Figure 3-7. Results are shown in Table 3-3.

TABLE 3-3. PULSE OUTPUT OF ISOLATED BIT
ON 5 MIL WIRE AFTER DISTURBS

Program	Output	
	0	1
A	-8.0 mv	+9.5 mv
B	-9.0 mv	+9.5 mv
C	-3.0 mv	+3.5 mv
D	-1.0 mv	+2.5 mv
E	+3.0 mv	-4.0 mv
F	-3.0 mv	+4.0 mv
G	-3.0 mv	+2.0 mv
H	+1.0 mv	-4.0 mv

These results are essentially the same as the results shown in Table 3-1. The threshold disturb test was also repeated with results shown in Table 3-4.

TABLE 3-4. MAXIMUM WORD CURRENT
FOR 50 PERCENT DISTURB

	Disturb Current	
	Left	Right
Bit 1	380 ma	450 ma
Bit 2	430 ma	450 ma

The results of these tests indicate that mechanically isolating the bits has negligible effect on the creep sensitivity. Thus, in these films, continuity of material has no effect on the energy required to propagate a domain wall through adjacent bits.

Work on the reduced diameter wires was then begun. The same type of magnetic film was plated on BeCu wire 2 mils in diameter. The word current was set at 500 ma \pm 15 percent and the digit current was 40 ma \pm 25 percent. A number of tests were then performed to characterize this wire.

The first test was a pulse program consisting of

10^4 x history, 1 x write and 10^4 x read

with a word current of 500 ma and digit current of 40 ma using the standard 5 mil wire test fixture. Outputs were \pm 11.5 mv. This output compared very favorably with the output of Program A in Table 3-1.

Next, a unipolar threshold write test using the program below was performed.

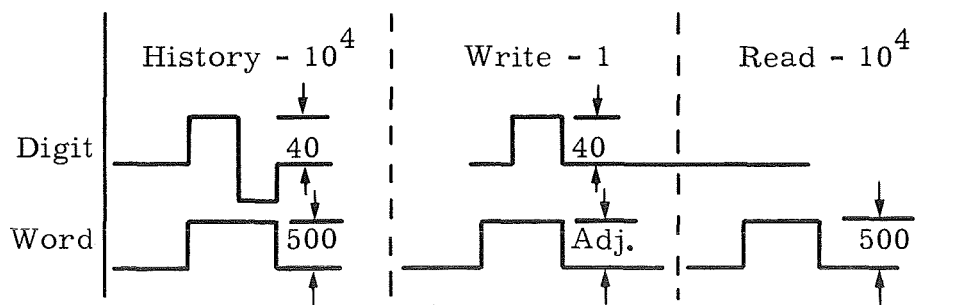

During the write cycle, an adjustable amplitude of word current was increased until 50 percent of the stored flux was reversed to give a zero output during the read cycle. For this wire in this test fixture, the required current was 170 milliamperes. Next, a bipolar digit current was used during the write cycle with results in various tests as shown in Figure 3-10.

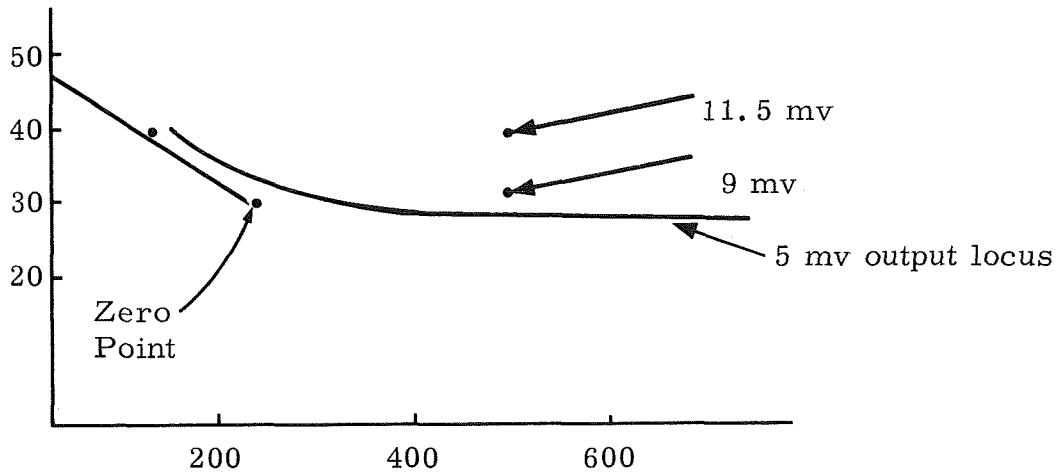
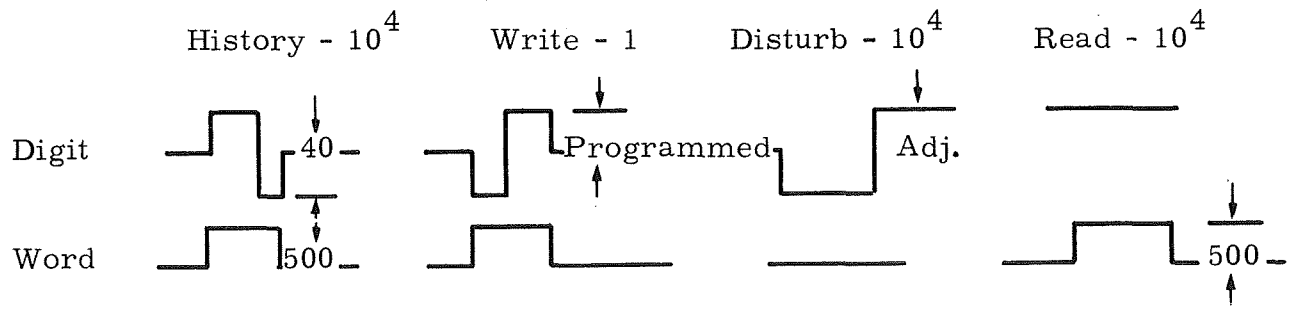

FIGURE 3-10. OPERATING POINTS FOR 2 MIL WIRE - 2μ Ni-Fe FILM

Note that the bipolar zero point is nearly the same as the unipolar zero point. An interesting feature of the 5 millivolt operating line is that word current requirements are approximately 200 milliamperes lower than for 5 mil wire.

The possibilities of using unipolar digit currents with this 2 mil wire were then investigated. The pulse program shown below was used.



Results are as shown in Table 3-5.

TABLE 3-5. UNIPOLAR DIGIT DISTURB THRESHOLDS

Write Digit Current	Disturb Digit Current
50 ma	20 ma
40 ma	18 ma
30 ma	17 ma
20 ma	Did not write

These results indicate that this film will not work in the unipolar mode. A number of these tests were repeated using tunnel structure with 3 mil holes versus the 7 mil holes of the standard test fixture. Differences in the operating current requirements were negligible.

It appeared that further changes must be made in the film geometry to move the operating points closer to contract objectives. At this point, reduction of the wire diameter and film thickness appeared the most promising moves.

Substrate beryllium copper wires having diameters of 0.5, 1 and 2 mils were plated at the Honeywell Corporate Research Center. This was done because mechanical problems made it impossible to continuously plate wires having diameters less than 2 mils on the Aero-Florida production wire plater. Work was concentrated on reduction of the wire size and film thickness since work by Pearl⁽⁵⁾ corroborated Mo's⁽⁴⁾ finding that the demagnetizing field of the bit is a major factor affecting allowable packing density.

Pearl has derived the expression

$$\lambda = (d t \chi)^{1/2}$$

for λ , a characteristic natural length or shortest length within which the magnetization can be localized. Here d is the wire diameter, t the film thickness and χ the hard axis susceptibility.

Thus reducing the wire diameter from 5 mils to one mil should permit increasing the packing density by $\sqrt{5}$ or going from bits on 50 mil centers to bits on 22 mil centers. Further reduction in bit length can be made by reducing t and χ . Chow⁽⁶⁾ shows that reducing χ by increasing H_k

(5) J. Pearl, 1968 Intermag Conference

(6) W. F. Chow, 1968 Intermag Conference

is effective. Unfortunately, word current requirements will also increase. Thickness reductions are limited by increases in dispersion as the thickness is reduced.

Testing was planned to determine the limits of packing density of reduced diameter wire with film parameters optimized for the objectives of this program. First, the 2 mil wires were tested in a fixture having 5 mil kept flat straps. Typical operating points are shown in Figure 3-11.

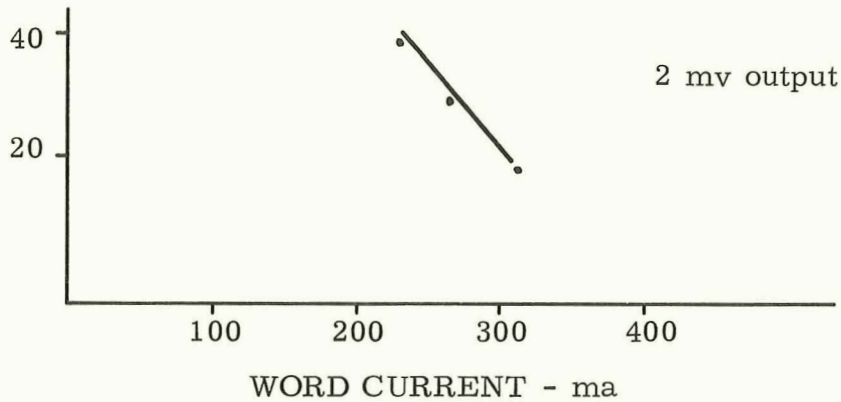

FIGURE 3-11. OPERATING POINTS FOR 2 MIL PLATED WIRE

For this wire, the unipolar digit disturb current was 40 milliamperes and so operating in a unipolar mode was possible. This wire was also tested for packing density by raising the word current in adjacent straps until 25 percent of the stored flux was reversed. Results are shown in Figure 3-12.

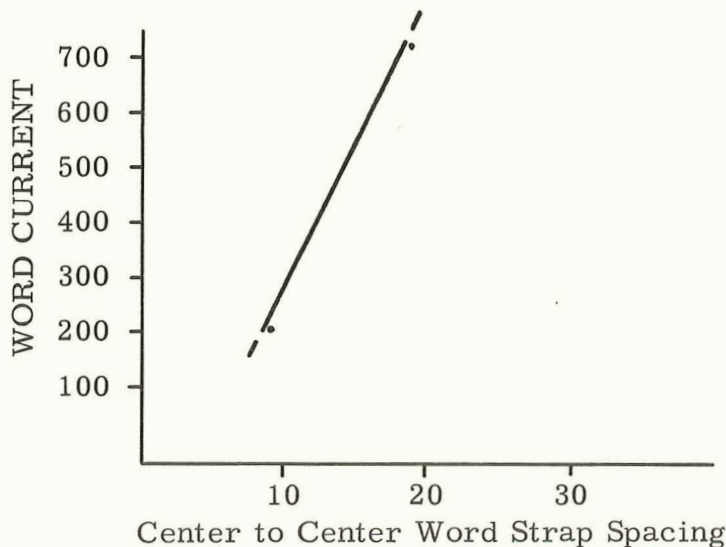

FIGURE 3-12. ADJACENT BIT INTERFERENCE VERSUS SPACING

Since the wire can operate with word currents in the range 300-400 milliamperes as shown in Figure 3-11, Figure 3-12 shows a possible packing density of 70 bits/inch using bipolar digit currents. Wires of smaller diameter would permit similar packing density using unipolar digit current.

To reduce word current requirements, two turn word straps, arranged as shown in Figure 3-13, were fabricated. These straps were assembled into a test fixture as shown in Figure 3-14.

Samples of 1.7 and 22 mil wire were characterized in the test fixture. Results are plotted in Figure 3-15. As can be seen by comparison with Figure 3-11, significant reductions in the required word current were possible with the two turn straps. However, Table 3-6 shows that creep again limits the packing density to approximately 70 bits/inch.

TABLE 3-6. ADJACENT BIT INTERFERENCE VERSUS SPACING

Bit Spacing	Wire Diameter	Output	
		Without ABI	With ABI
20 mils	2.2 mils	2.0 mv	1.4 mv
	1.7	2.5	1.7
15	2.2	2.0	0
	1.7	2.2	0.5

21151-FR

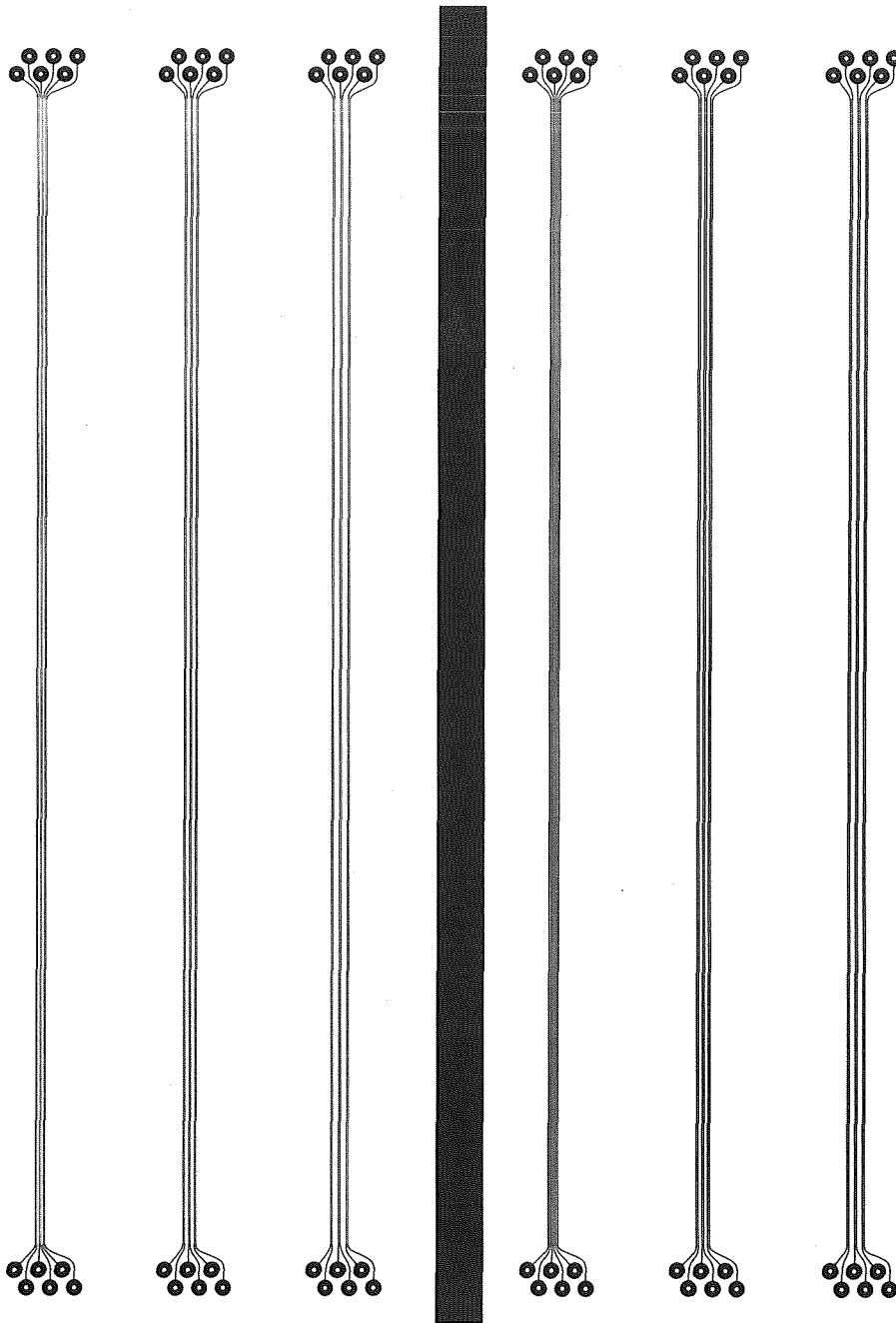

FIGURE 3-13. WORD STRAP TEST PATTERNS
10, 15, AND 20 MIL CENTERS

Strap - Space Widths in mils are: Left 2-2-2
Right 3-2-3

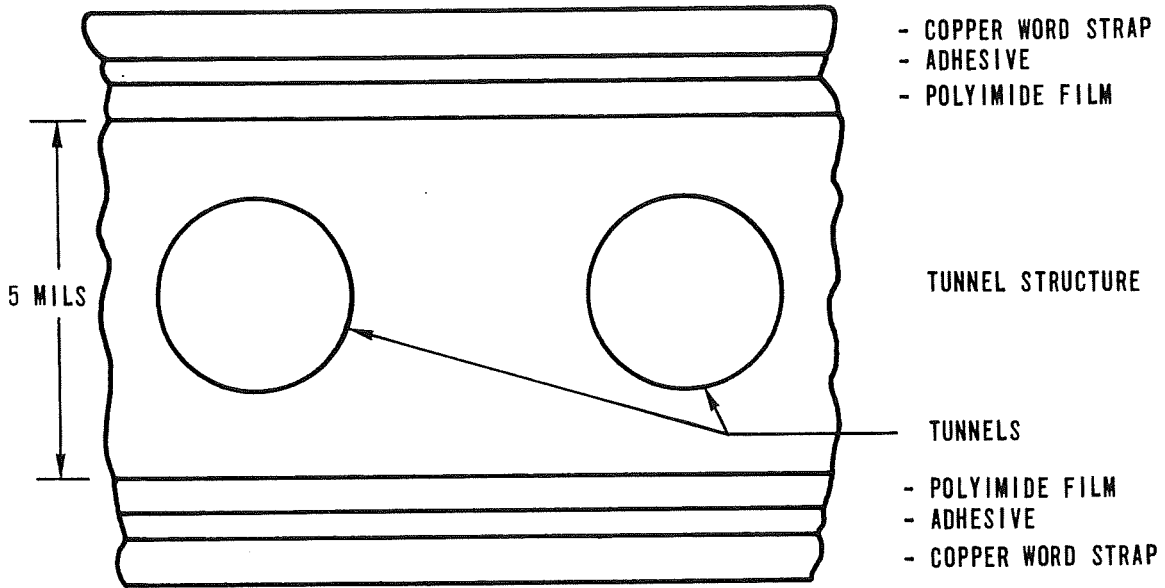

FIGURE 3-14. CROSS SECTION OF PLATED WIRE TEST FIXTURE

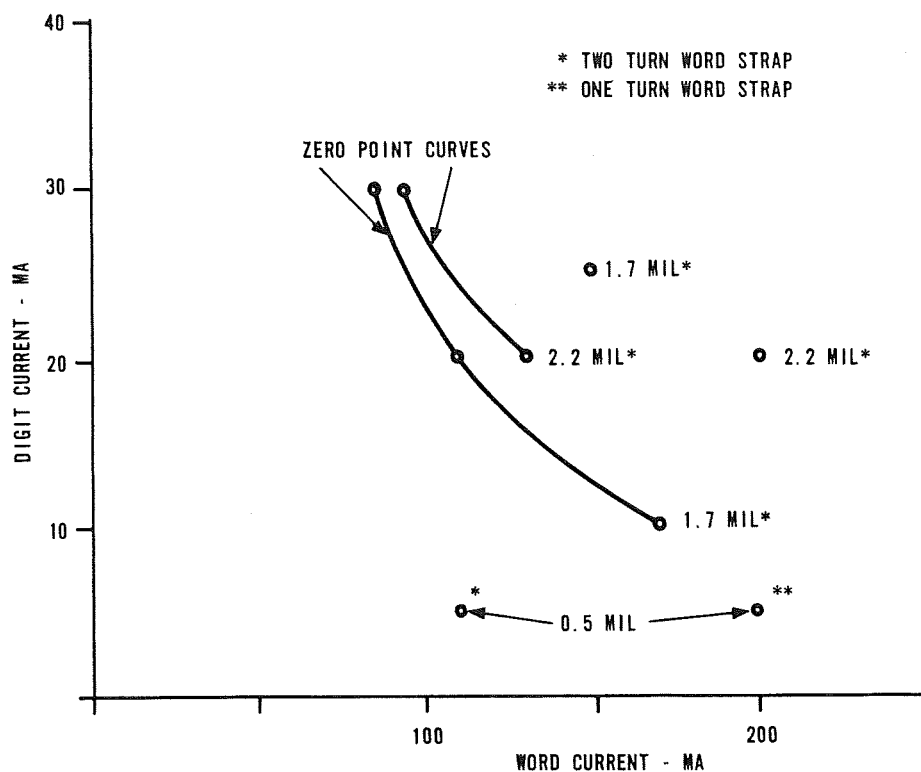

FIGURE 3-15. PLATED WIRE OPERATING POINTS

A sample of 0.5 mil diameter plated wire was then tested in the fixture using word straps on 10 mil centers. Creep reduced the output to zero. A repetition of the test with a single turn 2 mil word strap produced the same result. It was concluded that the separation between straps was too great.

Thus, a fixture as shown in Figure 3-16 was fabricated to reduce the spacing. Testing 1.7 mil wire in the fixture gave results as shown in Table 3-7. While information remains after the ABI program, creep has evidently seriously reduced the width and therefore the output of the bit.

TABLE 3-7. OUTPUT OF PLATED WIRE BITS ON 10 MIL CENTERS

Test Fixture	Wire Diameter	Drive		Output	
		I _o	I _w	Without ABI	With ABI
Figure 3-16	1.7 mils	16 ma	250 ma	0.9 mv	0.2 mv
	0.5	5	200	0.55	0.4
Figure 3-17	0.5	5	110	0.6	0.4

0868-44B

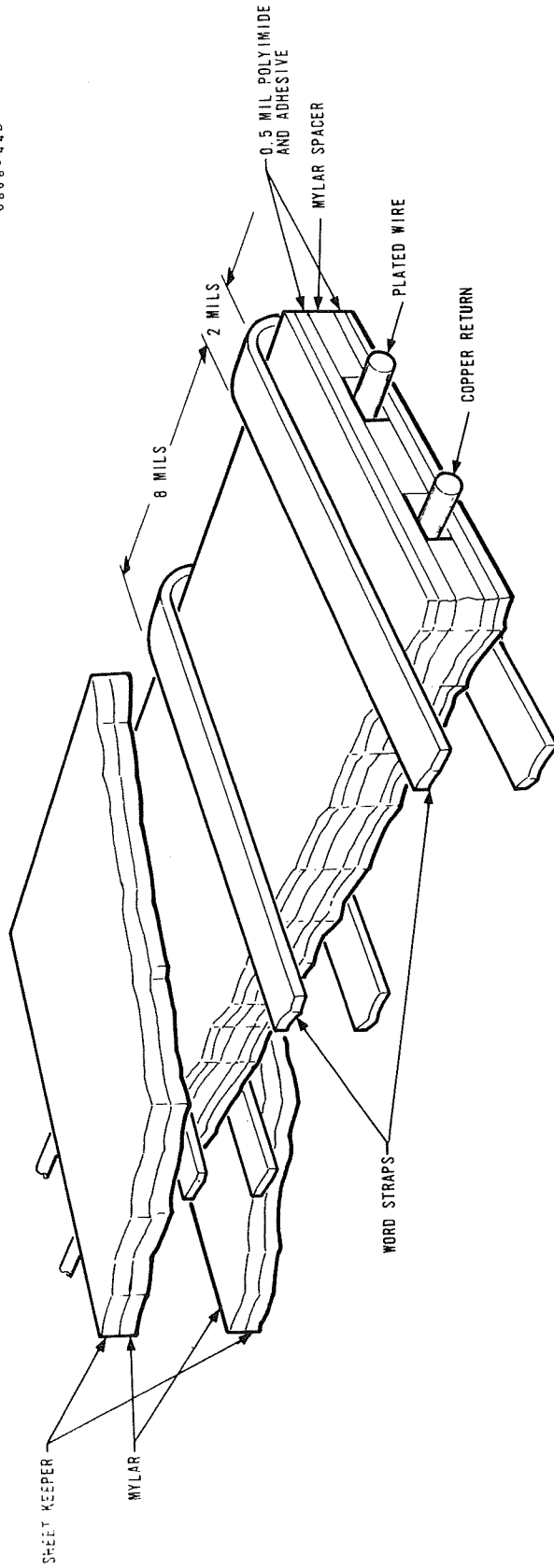

FIGURE 3-16. PLATED WIRE TEST FIXTURE FOR REDUCED DIAMETER WIRES

Reducing the wire diameter would reduce the demagnetizing field and thus the required word current which is partially responsible for creep, therefore the test was repeated with an 0.5 mil wire. Results of this test are also shown in Table 3-7. Waveforms are shown in Figure 3-18. The relatively minor disturb of the stored information indicates the program goal of 100 bits per inch is attainable with this wire.

To attain the same result with a lower word current, a two-turn word strap was fabricated as shown in Figure 3-17 and was used. Test results are shown in Table 3-7.

The value of 110 millamperes word current compatible with LSIC technology is in line with the program goal of 100 milliamperes word current.

Thus, it is evident that high density, LSIC compatible, plated wire memories are possible.

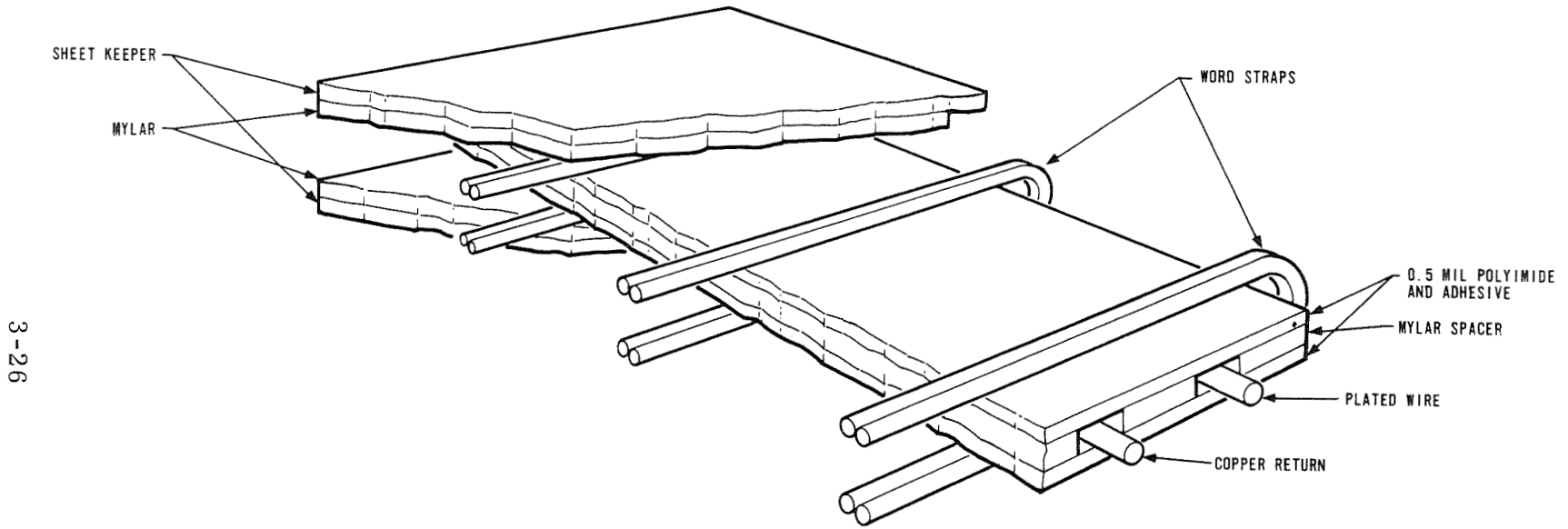

3-26

21151-FR

FIGURE 3-17. TWO-TURN TEST FIXTURE FOR TESTING 0.5 MIL WIRE

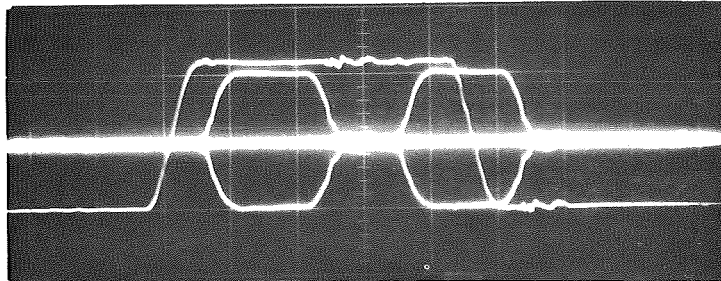

→ | | ← 100NS/CM

WORD/DIGIT OVERLAP

I_D 5MA/CM

I_w 50MA/CM

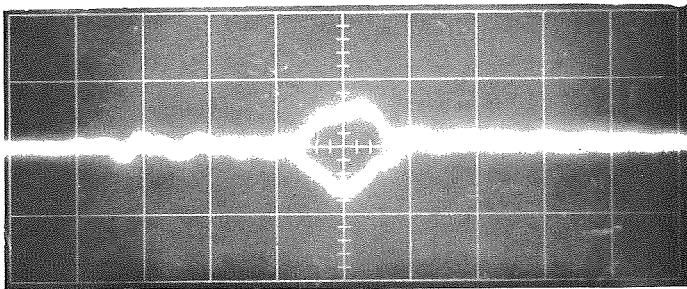

→ | | ← 50NS/CM

UNDISTURBED

"1" AND "0" OUTPUT

1MV/CM

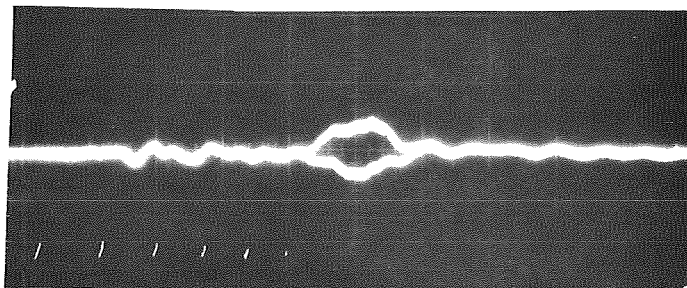

→ | | ← 50NS/CM

ABI DISTURBED

"1" AND "0" OUTPUT

1MV/CM

FIGURE 3-18. DRIVE AND OUTPUT WAVEFORMS

3.3 MEMORY SYSTEM CONSIDERATIONS

The availability of a plated wire suitable for high density packaging makes it possible to consider the other goals of this contract.

No Bipolar Digit Currents

While it was not possible to achieve 100 bits per inch on the 0.5 mil wire using unipolar digit current in the test fixture, it is possible to operate any diameter plated wire with unipolar digit current as long as the digit disturb current threshold is higher than the digit current required for writing.

The trade-off for utilizing the bipolar current is a reduction in the packing density for the specific wire diameter in the particular package. Thus, to recover the packing density of 100 bits per inch, reduction of wire diameter and/or improvement of the magnetic coupling between the wire and the word strap is necessary.

Since digit currents of both polarities must always be generated in a plated wire memory system, it is felt that the small amount of additional logic required for bipolar digit pulses is more than offset by the increased packing density possible.

Useful Lifetime of Five Years at 85°C

Lifetime of 0.5 mil wire is expected to be similar to that of 5 mil wire since the plating process is identical. By extensive testing Lutes and Cebulla ⁽⁷⁾ have shown 5 mil wire to have a lifetime in excess of five years.

Cycle Time One Microsecond or Less for A 10^6 Word Memory

Since reading and writing are by rotational switching, the element is very fast, essentially controlled by eddy currents. Proper film thickness will permit switching in the 10 nanosecond region.

Thus cycle time will be controlled by propagation delays and digit recovery time. For a 10^6 word memory, it was assumed 64 modular packages of 16K words would be used. To limit digit line length, the stack word would contain 16 computer words of 24 bits each, giving a stack organization of 1K x 384. The state of the art will permit read and write in this module in less than 1 microsecond. Thus time is available for operation of module selection circuitry.

⁽⁷⁾O. S. Lutes, T. J. Cebulla, 1968 Intermag Conference.

System Power Less Than 10 Watts

The basic power requirements for the memory are for word and digit drive and sense amplifiers. Assuming a word drive of 100 milliamperes and digit drive of 5 milliamperes, basic power requirements are:

$$\begin{aligned}
 0.100 \times 20 \times 0.4 &= 0.80 \text{ (Word)} \\
 0.005 \times 24 \times 20 \times 0.3 &= 0.72 \text{ (Digit)} \\
 0.150 \times 24 &= 3.00 \text{ (Sense Amplifiers)} \\
 \text{TOTAL} &= 5.12 \text{ watts}
 \end{aligned}$$

where

$$\begin{aligned}
 \text{Supply voltage} &= 20 \text{ volts} \\
 \text{Word duty factor} &= 0.4 \\
 \text{Digit delay factor} &= 0.3 \\
 \text{Word length} &= 24 \text{ bits.}
 \end{aligned}$$

Power consumption of the logic is dependent on the type of logic used, amount of power gating and access requirements. For example, it has been estimated that the standby power of a module using LSIC logic will be 5 watts. Thus, if only one module must be on at a time, system power can be approximately 10 watts.

System Cost of One Cent per Bit or Less

Packing densities of 100 bits per inch reduce the cost per bit of plated wire to the order of 0.1 cent. The use of LSIC for logic and drivers should bring the cost of memory system electronics to this same order of magnitude.

The major remaining cost is in assembly. Printed circuit techniques have dramatically reduced costs but major costs are incurred in inserting the plated wires into planes, interconnecting planes and completing the electronics assembly. Present trends indicate that in the near future, costs will be approximately 3 cents per bit.

Section 4

CONCLUSIONS

The operational demonstration of plated wire memory elements with bits on 10 mil centers at low power levels significantly broadens the range of applications for plated wire memories.

The packing density makes plated wire very competitive with ferrite cores, and the low power level insures compatibility with LSIC technology.

Effective use of smaller diameter wires will depend on development of compatible packages. Availability of these packages will probably dictate a step-wise increase in packing density, with modifications in presently available packages first being used for wires having diameters ranging from 1 to 3 mils.

Section 5

SUGGESTIONS FOR FURTHER WORK

The present techniques of packaging plated wire-tunnel structures, woven wire, etc. - are relatively costly operations. To achieve costs in the one cent per bit area, plane fabrication must be automated.

While it is conceivable that this operation can be automated for wires down to 2 mils in diameter using present types of plane structures, a new approach will be necessary for the finer wires.

Thus, it would be desirable to study packaging approaches permitting automated, batch fabrication of planes.

Another area deserving attention is the design of low cost sense amplifiers having higher gain than those presently available. Present types are adequate for the 5 to 10 millivolt signals available from 5 mil plated wire, but will not be adequate for signals in the order of 1 millivolt expected from the smaller plated wire memory elements.

Appendix A

WIRE PLATING AND TESTING

PLATING (See Figure A-1)

The process of plating wire inherently results in continuous memory element fabrication and testing. This technique does not exhibit the yield problems attendant with batch fabrication of entire bit arrays, i. e., fabrication of whole planes in one process. Memory element fabrication by

AG610-39-1

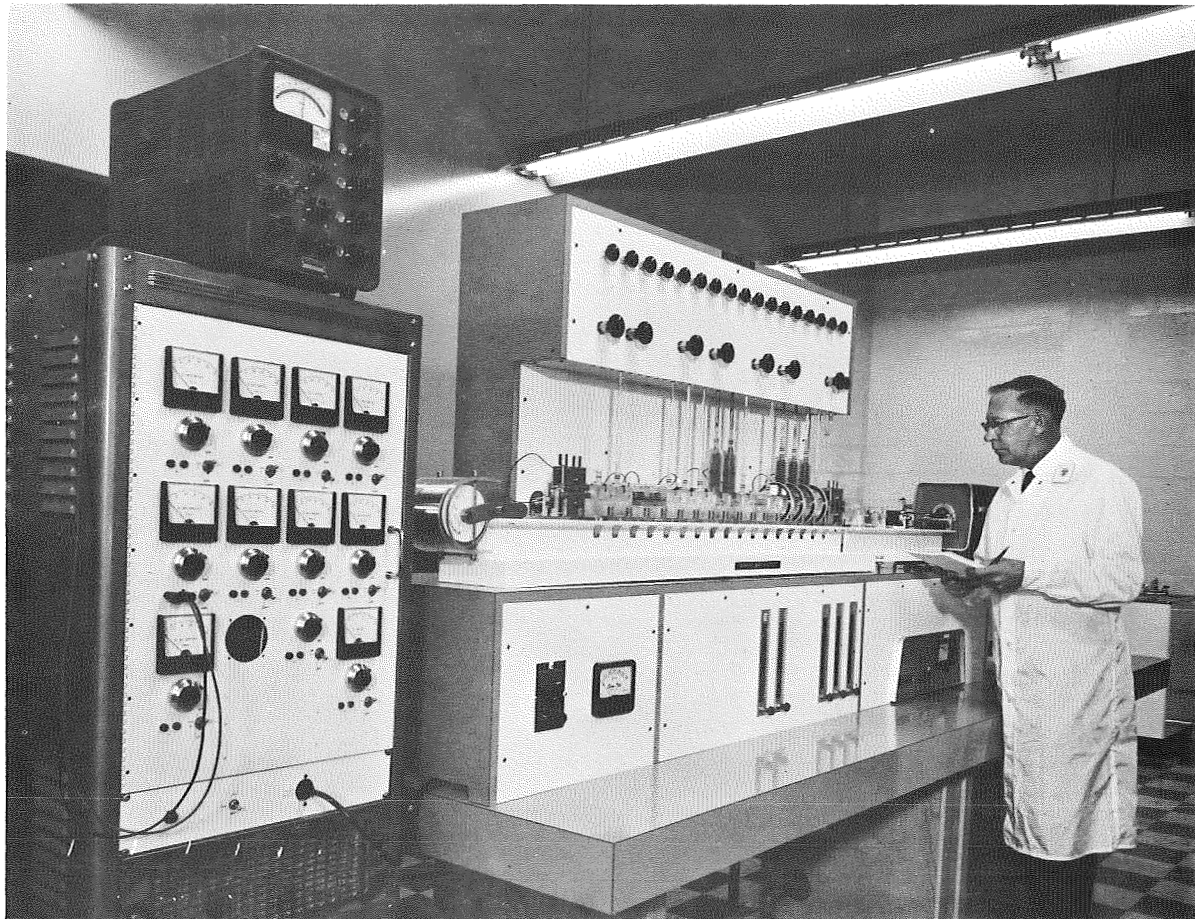

FIGURE A-1. WIRE PLATER

continuous plating, coupled with continuous testing immediately following deposition, lends itself to closed loop control.

The plater (Figure A-1) presently in operation at Aero-Florida is a product of extensive research by Honeywell's Corporate Research Center. This equipment performs all the necessary process steps to continuously produce plated wire.

Significant steps in the plating operation are shown in Figure A-2.

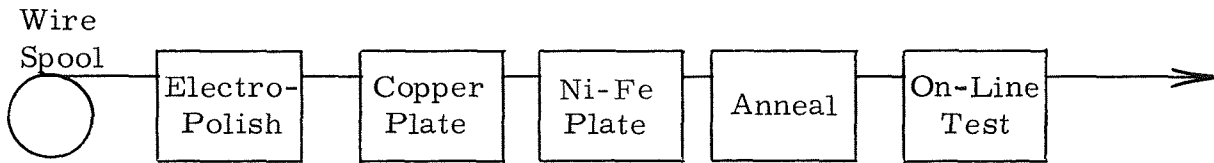

FIGURE A-2. MAGNETIC FILM PLATER
OPERATIONAL BLOCK DIAGRAM

Substrate wire is processed as follows:

Electro-polishing. This operation electrochemically removes contaminating films and minor surface imperfections from the substrate wire.

Copper Plating. A film of copper is plated on the wire to provide the proper substrate for the nickel-iron film.

Nickel-Iron Plating. This operation produces an anisotropic nickel-iron alloy film with an easy axis of magnetization along the circumference of the wire.

Annealing. This operation stabilizes the characteristics of the magnetic film.

Following these operations, the wire then moves to the on-line test station.

ON-LINE TESTS

During the time the wire moves 0.0025 inch, the following test sequence takes place:

1. Write "zero" under center strap 10^3 times in maximum current mode.
2. Write "one" under center strap once in minimum current mode.
3. Write disturb with "zero" under left strap, then read disturb under center strap, then write disturb with "zero" under right strap, continuing these three substeps for 10^3 times in maximum current mode.
4. With minimum word current read information under center strap and check for output.
5. Repeat steps 1 through 4 with complementary data.

The high and low tolerance current values used at this station are determined by the combination of the capability of the plater and the capability of the memory system into which the wire will finally be placed in use. Step number 1 maximally sets the magnetic film into the state opposite the test state. The test state element is then minimally set at step 2. Step 3 combines "creep" testing with interleaved high tolerance read disturbing the test element flux. Creep is defined here as the effect seen on the test element as a function of repeated write operations on adjacent elements. The final test is then performed by interrogating the test element once with a low tolerance current pulse.

Discriminator electronics sense the output of the element to determine if it is above the acceptable level. If the output is not acceptable, a cutter is signaled to cut the wire as a reject. The sequence of events which takes place while the wire moves 0.0025 inch constitutes 100 percent on-line testing.

OFF-LINE TESTS

The pulse tests described above omit testing a number of static parameters including:

Easy axis coercivity (H_c)

Hard axis break point (H_k)

Skew (β)

Dispersion (α)

Magnetostriction (η)

Lifetime.

These parameters are monitored with off-line tests and (together with on-line test data) are used for process control.

Appendix B

TUNNEL STRUCTURE FABRICATION

Testing of plated wire has repeatedly shown that the part of the magnetic circuit formed by the structure around the plated wire is a significant part of the memory design.

Much work to date has revolved around the use of multi-layer printed circuit board techniques which can produce structures such as that shown in Figure B-1.

The basic carrier structure is a simple sandwich of plated wires inserted between the two surfaces of a printed circuit board.

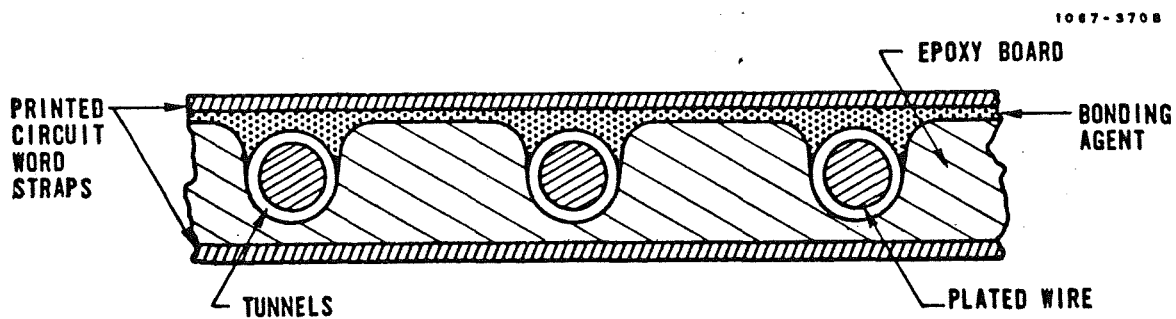

FIGURE B-1. BASIC CARRIER STRUCTURE

The tunnels provided for the wire at regular intervals are oversized to prevent stressing the film. Positioning the wire at an exact midpoint between the printed circuit word straps is not critical due to the low field gradient in that direction. Design of the word strap geometry is a trade-off of word power versus signal output. Maintaining this geometry is well within the limits of present day printing and etching techniques.

If desired, magnetic keepers can be added over the word straps to reduce word current requirements and increase permissible packing density. Since the effectiveness of the keeper depends on effectively closing the word current flux path, the thickness of the basic carrier structure should be consistent with the wire diameter.