

N70-30072
NASA-CR-102731

Westinghouse Research Laboratories
Pittsburgh, Pennsylvania 15235

ZERO GRAVITY CRYSTAL GROWTH

M. Rubenstein, C.S. Duncan, R. Mazelsky

FINAL REPORT

NAS 8-24509

April 29, 1970

Prepared for George C. Marshal Space Flight Center
Marshal Space Flight Center, Alabama

CASE FILE
COPY

Westinghouse Research Laboratories
Pittsburgh, Pennsylvania 15235

ZERO GRAVITY CRYSTAL GROWTH

M. Rubenstein, C.S. Duncan, R. Mazelsky

FINAL REPORT

NAS 8-24509

April 29, 1970

Prepared for George C. Marshall Space Flight Center
Marshall Space Flight Center, Alabama

TABLE OF CONTENTS

	<u>Page</u>
I. INTRODUCTION.....	1
II. DESCRIPTION OF SYSTEM	
A. General Design Features.....	4
B. Apparatus Design.....	5
C. Ampoule Design.....	7
III. ASSEMBLY OF SYSTEM	
A. Ampoule Assembly	
1. Materials Preparation.....	9
2. Loading and Sealing.....	12
B. Apparatus Assembly	
1. Crystal Growing Chamber.....	15
2. Instrument Package.....	19
IV. OPERATIONAL RESULTS	
A. Power and Temperature Relationship.....	22
B. Voltage Requirement.....	22
C. Heating and Cooling Rates.....	22
D. Crystal Growth.....	23
V. CONCLUSIONS AND RECOMMENDATIONS.....	27

I. INTRODUCTION

The availability of a zero gravity environment for extended periods of time permits the control of an additional parameter in scientific experimentation. The processes in which the zero gravity environment can have the most dramatic effect are those which involve the presence of a liquid in which density variations are present as a result of which, convective currents are formed. Many of processes concerning materials involve the liquid state and, as such, are subject to the effects of convection resulting from gravity. One of the most important of these is the solidification of a liquid in a controlled manner to produce a desired solid. Crystal growth is a technique that is quite sensitive to the effects of convection during the solidification process. As a result it is one of the phenomena most suited for examining the potential beneficial effects of a zero gravity environment.

The number of experiments in crystal growth that can be conceived is almost limitless. One can design many variations of experiments utilizing different growth techniques to synthesize any one of many possible crystals. Most of these would yield valuable scientific information and would demonstrate what advantages may be derived from zero gravity growth. However, space technology is still in its infancy and the weight, equipment complexity, and power requirements are limiting factors in any experiment to be conducted. In addition it is of importance to consider the level of training required of the operator as well as the time demands of a given experiment in order to determine the feasibility

of conducting a worthwhile study in an area which too often depends on the skill of an operator.

When these considerations are totaled solution growth becomes a very attractive process for the early experiments in crystal growth at zero gravity. This is true for several reasons:

1. It is fundamentally a relatively low temperature process. It depends on the solubility of a given material in a solvent and not on the melting point of the material. As a result problems associated with high temperature operation such as equipment deterioration, high power requirements, and high vapor pressure are minimized.
2. The successful growth of crystals is not as dependent on variables such as minor temperature transients and vibration as other forms of growth which depend on direct solidification from the melt.
3. Solution growth is an old and versatile technique. It has general applicability to many compounds and with proper equipment design, can be used to grow a variety of compounds with only minor modifications to the equipment. In addition it is a technique that is particularly sensitive to convection and as such can yield data applicable to determining the effect of zero gravity on crystal growth.
4. It is a relatively simple method to operate and, as a result, requires a minimum of operator time during the experiment. Since complex equipment is not required and no moving mechanical components are needed, the reliability of equipment is enhanced and the probabilities of a successful run are greater.

The boundary conditions set on the early crystal growth experiments are that

1. weight of the experimental package should not exceed 10 lbs.
2. power requirements should not exceed 150 watts
3. safety standards should not be compromised
4. the astronaut should not have to devote an excessive amount of time to the experiment during operation.

We have met these standards and have successfully demonstrated the growth of crystals in our experimental package. Although the package is designed to grow experimental crystals of gallium arsenide from a gallium solvent, other crystals and different solvents may be used routinely with minor variations in the package.

II. DESCRIPTION OF SYSTEM

A. General Design Features

The boundary conditions listed in the Introduction were of necessity the first requirements which had to be satisfied. An additional prime requirement was to accommodate the crystal growing ampoules which are essentially of slender cylindrical shape. The final package which evolved, shown in Drawing 4857D32, is therefore cylindrical, being $11\text{-}\frac{7}{16}$ inches long by 4 inches in diameter, excluding the flanges which are $5\text{-}\frac{1}{4}$ inches in diameter. The longer cylinder, $8\text{-}\frac{3}{16}$ inches comprises the crystal growing chamber whereas the shorter cylinder, $3\text{-}\frac{1}{4}$ inches, houses an instrument package supplemental to the crystal growing.

It was decided at the outset that the necessary ampoule temperature gradient would be achieved by applying a single electrical heating element to the high-temperature end in conjunction with a heat sink of designed thermal resistance applied to the lower-temperature end of the ampoule. This arrangement is in contrast with usual laboratory practice which utilizes a multiple winding furnace to provide two temperatures necessary to produce a desired gradient.

A completely hermetic design with a high vacuum valve was chosen in order that all storage and transportation of the apparatus could be done while the system was hermetically closed. The valve is required in order that the apparatus may be opened to space and thus have the advantage of vacuum insulating properties during the crystal growing experiment.

A large area flange is provided at the cold end of the crystal growing chamber in order to serve as a thermal conduction interface with an appropriate heat sink to be provided in the space vehicle. The instrument package housing is located on the axially-opposite side of the flange in order to provide it with a minimum temperature. The flange of the crystal growing chamber is constructed with two interspaced sets of eight mounting holes, one set of eight for mounting to the heat sink and the other set for mounting to the instrument housing.

B. Apparatus Design

The main housing for the crystal growing chamber is shown in Drawing 253C464. The outer stainless steel can contains a built-in radiation shield which in turn accepts the three heating elements and three heat source shields as shown in Drawing 4857D32. The construction utilizes mounting pins and fingers located in such a manner as to maximize the length of path of conducted heat from the heat source to the outer housing. In addition, thin wall construction sections have been used in order to further limit the flow of conducted heat. Two radiation shields are located between the heat sources and the cold ends of the ampoules. No radiation shields are provided at the cold ends of the ampoules since a substantial amount of thermal conduction is purposely designed into the mechanical support members which connect the flange to the cold ends of the ampoules.

The Nichrome V heating elements are wound directly onto the hot ends of the ampoules. Windings are 16 turns of 1/16 inch wide ribbon

with the thickness selected to match the desired supply voltage when consuming the required power. In order that the heating ribbon may be safely held at the desired spacing on the ampoule it was necessary to grind an accommodating helical groove into the outer wall of the ampoule hot ends, as shown in Drawing 253D438. Two quartz loops are fused onto the ampoule walls near the inward end of the ground helix to serve as tie points for the ends of the heating element. At the opposite end of the ground helix a 0.075 inch diameter hole is located to serve as a tie point and as a route for the return power lead for the end of the ribbon which is wound to the extreme end of the ampoule. Two concentric quartz cups fit over each heating element with the return power lead passing between them as shown in Drawing 4857D32. Small bore quartz tubes enclose the ribbon power leads starting at the termination at the quartz loops previously mentioned and extending to the terminal tie points located in the instrument housing. Quartz fibre batting (felt) is fitted between the two quartz cups on each ampoule and also between the outer quartz cups and the inside of each of the three stainless steel cups of the tube support assembly, Drawing 721B942, which holds the three hot ends of the ampoules. The quartz batting serves the dual purpose of acting as a mechanical cushion while also providing added thermal radiation shielding.

The clamping arrangement for the cold ends of the ampoule must serve not only to mount and align the ampoule but must also provide a prescribed amount of thermal conduction to the flange and heat sink. This construction is shown in Drawings 4857D32, 253C465 and 253C466. The conduction is largely determined by the geometry selected in

items 1 and 2 of Drawing 253C465 and item 13 of Drawing 253C466. Final minor adjustments of conduction may be made if desired, in selection and forming of the packing medium fitted between the cold end of the ampoule and the cold-end clamp, and additionally in selection of the conduction rod diameter. To serve the purpose of this experiment it is desirable to 1) fill the entire area between the clamp and the ampoule with tightly compacted grade 000 steel wool and 2) use a 1/4 inch diameter nickel conduction rod.

Numerous items are housed in the instrument package: 6 thermocouple reference junctions, 2 thermostatic elements, high vacuum valve, hermetic electrical receptacle, and mechanical tie points for 6 thermocouples and 6 power leads from the heating elements. This arrangement is shown in Drawing 4857D32. The electrical wiring connections are shown in Drawing 253C951. The complete list of all design drawings is given in Design Specification D763614.

C. Ampoule Design

The ampoule used in these crystal growing experiments during the course of this investigation was made up of several components:

- (1) a quartz tube, (2) a quartz disk, (3) a quartz plug and fingers,
- (4) source GaAs, (5) seed GaAs, and (6) gallium metal.

The quartz tube is 19 mm O.D. and 13 mm I.D. A tube with 3 mm wall thickness is used both for strength and so that a spiral groove could be ground into the wall in order to wind a heating ribbon on the ampoule. The heat source is described in Section IIB.

The closed end of the quartz tube is a disk (see Fig. 253C438) 1/4" thick which is sealed on the end of the quartz tube. Grooves are ground on this closed end of the quartz tube to a depth of 0.030" in the wall of the 3 mm quartz tube. These ground grooves are then fire polished to remove small cracks and strains. The grooves are ground 8 threads per inch, each groove is 0.060" wide, and the length of the grooved area is 2-1/4". A hole 0.075" diameter is cavitared 0.12" from the very end of the tube, through the 1/4" thick plate sealed over the end of the tube. At a distance of 2.781" from the closed end of the quartz tube are two loops, labeled "3" in Drawing 253C438 sealed onto the quartz tube. The loops consist of quartz tubes cut in half axially. They are then heat sealed on the opposite sides of the quartz tube lined up with the 0.075" diameter hole cavitared through the closed end of the quartz tube. This hole and two loops are used to help wind and hold the nichrome ribbon in position.

The three indentations at section "A"- "A" in Fig. 253C438 are used to position the quartz disk (see Fig. 860A032) until the disk is sealed into place. The purpose of the quartz disk is to contain the GaAs source material in the hot section, or GaAs source section, of the ampoule. Originally, we used a disk with holes cavitared through the disk, however, we found that the cut-out version of the disk better served our purposes. Cavitating many large holes through the disk resulted in a high rejection rate of the disks because of cracking and chipping during cavitation. By going to a cut-out disk as shown in Fig. 860A032 the rejection rate was very low, the ease of increasing the ratio of

open to closed portion of the disk was increased, and the chance of the openings being clogged by GaAs crystals was decreased.

The set of indentations of "B"- "B" closest to the closed end of the tube was to position the GaAs seed. The purpose of the next set of indentations at "B"- "B" was to position the quartz plug and fingers. The fingers rested on one side of the seed and the other indentations (closest to the closed end of the tube) supported the other side of the seed 90° from the fingers support (see Fig. 722B216).

The use of the plug and fingers was decided as an excellent way to seal a tube while the GaAs and gallium were under vacuum, and help hold the seed at the same time. The distance between the seed and the beginning of the seal could be varied by simply changing the distance between the positioning of the two sets of indentations at section "B"- "B" (Fig. 253C438) and the length of the fingers of the quartz plug and fingers. The use of the plug for sealing is a technique which causes less strain and greater wall strength. The plug is hollow which allows us to use a heat sink to unidirectionally remove heat from the ampoule.

III. ASSEMBLY OF SYSTEM

A. Ampoule Assembly

1. Materials Preparation

The components necessary to assemble the ampoule for crystal growing are: quartz tube with ground spiral, quartz disk, quartz plug and fingers, source (gallium arsenide), seed (gallium arsenide), and

gallium. They are prepared prior to final assembling by a variety of techniques.

The quartz pieces of this assemblage were all boiled in concentrated nitric acid for one hour, cooled, washed three times with demineralized water, drained, heated overnight in a clean oven maintained at 250°C, and cooled to room temperature. All quartz pieces were stored after cleaning in flat polyethylene tubing.

The gallium metal (99.9999% gallium) was melted into 8 mm I.D. quartz tubes. The tubes filled with liquid gallium were cooled in liquid nitrogen until the difference of coefficients of contraction between quartz and gallium cracked the tubes. With the judicious use of a small hammer the quartz was removed from the cast gallium ingots and the gallium ingots were placed in a covered beaker in a refrigerator until ready for use. Approximately 75 grams of gallium were used per run.

The GaAs source material consisted of pieces approximately 6 x 6 x 10 mm in size cut from sound polycrystalline material. The GaAs was mounted with bees wax and rosin for cutting. The mounting wax was removed by boiling with trichlorethylene, acetone, and then with methanol. The GaAs was then boiled with demineralized water twice, boiled with concentrated hydrochloric acid for 15 minutes, and finally rinsed with demineralized water six times. The final water washing was then decanted off and the GaAs was placed in a vacuum oven at room temperature overnight. Approximately 10 grams of GaAs were used per run.

The GaAs seed material was from an undoped single crystal ingot of high electron mobility ($> 8,000 \text{ cm}^2/\text{volt sec}$) at room temperature.

This would correspond to a purity of greater than 99.9999% GaAs. This material was nominally grown in a $\langle 111 \rangle$ orientation. Using x-ray diffraction Laue patterns, the $\langle 111 \rangle$ orientation was ascertained $\pm 1/2^\circ$ and slices cut. The thickness of these slices after cutting was about 1.5 mm. Disks were then cavitated (using an ultrasonic vibrator with abrasive) so that a disk was obtained with a 12 mm diameter.

These disks were then cleaned with trichlorethylene and etched with a solution of H_2SO_4 , H_2O_2 , H_2O (5,1,1) to remove any damaged layer caused by the diamond saw and cavitating.

The disks were mounted on lapping block and lapped smooth on a Mazur lapping machine using 305 lapping powder (5 micron diameter abrasive). They were then mechanically polished on a Syntron polishing machine using Linde "A" abrasive ($.1\mu$ diameter) for about 5 hours. The mounted disk was then given several quick cleanings with trichlorethylene to remove the abrasive particle. The last cleaning was in an ultrasonic vibrator. The mounted disks were then placed in a flat bottomed jar with a very smooth flat teflon disk at the bottom of the jar. The jar was mounted at a 45° angle from the horizontal. The mounted disks of GaAs were placed upon the teflon disk and a solution of H_2SO_4 and H_2O_2 (16:1) was introduced so that the solution level was above the GaAs. The jar was then rotated to give motion between the flat teflon and the GaAs seed with a thin fresh layer of etchant. This was the chemical polishing phase of this seed surface preparation.

If the face that is exposed to the polishing is the (111) or gallium face, the surface takes on a very good mirror polish. However,

if the same technique is used on a ($\bar{1}\bar{1}\bar{1}$) or arsenic face, the surface takes on a matte appearance.

After the chemical polishing the disks were dismounted with boiling trichlorethylene and treated in the same manner as the GaAs source material was as described above.

The final size of the $\langle 111 \rangle$ oriented GaAs seeds after polishing and cleaning was approximately 12 mm in diameter x 1.2 mm in thickness. The weight of these seeds was approximately 0.8 grams. Growth was attempted with either the (111) face (gallium) toward the hot end of the ampoule or with the ($\bar{1}\bar{1}\bar{1}$) face (arsenic) toward the hot end of the ampoule.

2. Loading and Sealing

The quartz tube (Drawing 253C438) was weighed, a weighed amount of GaAs source material was placed in the bottom (closed off portion of the tube) and the quartz disk (Drawing 860A032) was placed in position so that the three indentations at Section "A"- "A", Drawing 253C438, were immediately below the non cut-out portions of the quartz disk. When the tube was in a vertical position with the open end at the top, the quartz disk rested on the 3 indentations at Section "A"- "A". The tube was placed on a vacuum system in this same vertical mode and evacuated to a pressure of less than 10^{-5} torr. By using a hand torch (oxygen-hydrogen) heat was applied to the three areas immediately above the 3 indentations of the quartz tube so that the quartz tube wall flowed to the non cut-out portions of the quartz disk. The quartz disk was

sealed to the quartz wall of the tube at 3 positions. The sealing operation was performed under vacuum to prevent the formation of amorphous quartz which is apt to form when heating quartz to the yield point in the presence of moisture and/or oxygen. In addition the vacuum is necessary during this operation to prevent oxidation of the GaAs source material. To prevent the GaAs from becoming overheated, a wet paper towel was positioned around the lower portion of the quartz tube, beginning immediately below the 3 indentations. In this way the GaAs was not only not subject to oxidation but was prevented from even being heated during the sealing of the quartz disk to the quartz tube wall.

The cast gallium ingots (8 mm diameter) were removed from the refrigerator and placed in a vacuum oven at room temperature to remove any moisture. Approximately 75 grams of this cast gallium were placed in a beaker with a watch plate cover and the ingots were covered with liquid nitrogen. If an ingot of gallium at room temperature were allowed to slide down the side of the quartz tube, the ingot would leave a smear of gallium on the wall of the tube because of the malleability of gallium at room temperature. At lower temperatures no such problem arose.

Ingots of gallium were loaded (handled with teflon coated forceps) into the quartz tube within 1/2" of the top of the quartz tube. These ingots should pass through the indentations at sections "B"- "B" (Drawing 253C438) and the bottom ingot should rest on the quartz disk sealed to the ampoule wall just above section "A"- "A". This loading should proceed quickly and the quartz tube should then be evacuated to a pressure of about 10^{-5} torr.

Heat was applied to the bottom gallium ingot around the disk to melt the ingot. This heating was done with a relatively cool flame. When all the gallium was melted, the temperature was allowed to cool to room temperature, while the quartz tube was still under vacuum. The liquid gallium was then heated to about 50°C and the quartz tube was removed from the vacuum system. More gallium ingots were loaded in the tube, the tube was evacuated, the gallium was melted. This operation was repeated until the liquid level of the gallium was about even with the top of the lower set of the indentations at "B"- "B" (see Fig. 253C438). The reason for heating the liquid gallium to 50°C was to prevent the gallium from freezing in the tube while adding additional cooled gallium ingots.

The GaAs seed (previously weighed) was then positioned, past the top set of indentations at "B"- "B", resting on top of the lower set of indentations at "B"- "B". The quartz plug and fingers (Drawing 860A250) was then lowered into position with the fingers resting on or almost resting on the GaAs seed. The top of the fingers had to go in between the upper set of indentations. The assembled tube was then evacuated. When the pressure was less than 10^{-5} torr, the gallium was heated using a hand torch to about 300°C to remove most of the gas entrapped by the gallium. Gentle tapping helped the entrapped gas leave the tube. The tube remained on the vacuum system overnight. By morning the pressure was usually less than 10^{-6} torr.

A wet paper towel was draped around the tube immediately below the upper set of indentations at "B"- "B" to prevent heating of the seed and gallium. By carefully heating the quartz tube wall immediately above

the upper set of indentations at "B"- "B", the quartz tube wall was collapsed on the outer wall of the plug of the quartz plug and fingers. The hand torch was used to make this seal-off around the entire circumference and then around the rest of this plug. This is critical since, if too much heat is applied in making this seal, the inner wall of the quartz plug will deform and even collapse. If even appreciable deformation occurs in this inner wall of the plug, the heat sink cannot be set. When the sealed off tube cooled to room temperature, it was removed from the vacuum system. A measurement was made from the bottom of the quartz tube to a point 6-7/8" up, since the apparatus which is designed to hold this tube during the crystal growth runs can use a tube no longer than 7". At this mark of 6-7/8" the end of the tube was cut off on a silicon carbide cut-off wheel. The tube which had its end cut-off was then fire polished to seal up all microcracks which developed during the cut-off. This sealed tube comprises our crystal growth ampoule. In Drawing 722B216 we can see the sketch of the quartz tube (1), the quartz disk sealed in place (2), the GaAs seed (4), held by the fingers (3) of the plug and fingers and by the lower set of indentations called "B"- "B" in Drawing 253C438.

The ampoule must be maintained at a temperature in excess of 30°C to prevent the gallium from freezing and thereby cracking the ampoule.

B. Apparatus Assembly

1. Crystal Growing Chamber

The bench assembly fixture, Drawing 253C505, is essential to

assembly of the crystal growing apparatus. With this fixture, all mounting and alignment of the ampoules and accessory parts may be carried out completely independently of the housings for the crystal growing compartment and the instrument package. It would otherwise be very difficult if not impossible to properly assemble the system.

Prior to assembly of the ampoules in the apparatus, the heating elements must be wound onto the ampoules and affixed at the quartz termination loops. To do this a single thickness of ribbon should be passed with a single full turn through one termination loop, wound along the ground helical groove, fed through the 0.075 inch diameter hole at the end of the helix, passed through the hole in the quartz cup, Drawing 721B919, and finally returned along the outside wall of the quartz cup to the return quartz termination loop to which it should be affixed with a single full turn. From the termination loops three thicknesses of heating element ribbon, for reduced heat production should be attached for later connection to the heating element tie points, Drawing 4857D32, item 15, in the instrument package.

In order that the ampoules may be mounted, it is first necessary to mount the alignment plate sub-assembly, Drawing 253C465 into item 3 of the fixture assembly, Drawing 253C505. After the heat shield sub-assembly, Drawing 721B960, is affixed to the alignment plate sub-assembly the first ampoule may be mounted into the split tube, Drawing 253C465, item 2. Preparatory to mounting the ampoule, the split tube should be lined with a suitably pre-formed cylinder of pre-cleaned grade 000 steel wool. The ampoule must be oriented such that the heating element return

ribbon, which passes axially along the quartz cup, is facing the outside wall of the crystal growing housing. After the ampoule has been fitted into the steel-wool-lined split tube, the 120° spaced set screws, item 9, Drawing 253C466, may be tightened lightly. It is necessary to satisfy two requirements in tightening the set screws, 1) the ampoule must be aligned exactly as subsequently required for fitting to the tube support sub-assembly, Drawing 721B942, and 2) sufficiently tightened in order to be rigid and to provide good thermal conduction through the compacted steel wool. To obtain proper alignment with the tube support sub-assembly a cut-and-try procedure must be made by temporarily placing the tube support sub-assembly into item 2 of the fixture assembly, taking care that the key and keyway are mated. By careful adjustment of the set screws the ampoule hot end must be made to center exactly into the proper cup of the tube support sub-assembly. The remaining two ampoules should be mounted in a like manner. These steps must be made with the stop, Drawing 859A983, removed from the bench assembly fixture.

Next the three longer thermocouples must be fed through the center line thermocouple holes and formed to lie, one to each ampoule, against the outer wall of the smaller quartz cup at a position nearest to and parallel to the center axis of the assembly. Thus they will be 180° opposite the heating element return ribbons on each ampoule. The junctions of the thermocouples should be positioned one inch inward from the end of each ampoule. The handling of the thermocouples in the instrument package will be described later in these instructions.

The larger quartz cups, Drawing 721B920, should be completely lined, bottom and side, with pre-formed quartz batting and then slipped onto the three smaller quartz cups, Drawing 721B919, which had previously been mounted onto the ampoule hot ends. Care should be taken to enclose the three thermocouples in this step. The three stainless steel cups of the tube support sub-assembly should be similarly lined with quartz batting in preparation for it to be slipped as a unit, onto the three ampoule hot ends. Before this step is taken, it should be determined that the ampoules are axially positioned accurately such that the ends of the ampoules are equally spaced to extend exactly, with some compression of the quartz batting, to the bottom of each of the cups of the tube support sub-assembly. For this fitting the bench fixture stop must be mounted in its normal position.

The three nickel heat conducting rods, item 13, Drawing 253C466, and the cups, item 8, may next be approximately fitted to the three ampoules. After the approximate fitting the nickel rods should be cut to appropriate lengths to fit the ampoule cold-end cavities. The ends of the nickel rods should be wetted by being mechanically abraided with liquid gallium. A gallium-wetted nickel wool pad should next be placed into position in the bottom of each ampoule cold-end cavity. The nickel rods may then be permanently mounted and tightened against the nickel pads by screwdriver adjustment. The nut and lock washer should finally be applied in order to lock the position.

Quartz tubing 2.35 mm bore X 4.80 mm O.D. should next be slipped over the heating elements. This tubing may be cut to convenient lengths for this purpose making certain that no ribbon is allowed to be exposed

at any point where electrical contact may occur.

The three shorter thermocouples may now be fed in through the center hole and gently bent into a 180° curve such that they will lie flatly against the ampoules with their junctions exactly adjacent to the seeds. The first ampoule and thermocouple should then be wrapped with an overlapped full turn of full thickness batting and tied in place with two or three turns of quartz cordage. This wrapped area should then be drawn tightly by the thermocouple clamp, Drawing 861A149. The remaining two ampoules and thermocouples should be prepared in a like manner.

The cylindrical portion of the tube support sub-assembly, Drawing 721B942, should then be wrapped with quartz batting between the end plates and tied with quartz cordage. In a similar manner, quartz batting and cordage should be applied to the ampoules, 1) in the region between the tube support sub-assembly and the first baffle, 2) between the two baffles, item 6, Drawing 253C466, and 3) between the second baffle and the split-tube clamp.

2. Instrument Package

One lead from each of the heating elements should be combined into a single lead and spot-welded to provide good contact. The other three leads from each heater should then be combined similarly. The two new leads should be looped through the most convenient holes in the termination plug, Drawing 861A030, and silver brazed to the final two leads for subsequent connection to the hermetic electrical receptacle, pins 21 and 24 as shown in the Wiring Diagram, Drawing 253C951.

Before their assembly into the crystal growing chamber, the thermocouples should be mounted and brazed into the thermocouple plate,

Drawing 861A047, such that the sheaths project approximately 1/2 inch beyond the plate. Also prior to their assembly into the crystal growing chamber, a one turn loop should be formed in each thermocouple such that the loop will occur between the mounting plate, item 16, Drawing 4857D32, and item 7, Drawing 253C466 when they are mounted in their final positions. The loops should be of roughly one inch diameter with their axes parallel to the ampoule axis.

The storage thermostats, item 28, Drawing 4857D32 may now be installed on the mounting plate. These thermostats are required in order to prevent freezing of the gallium during storage periods. One serves to control a low voltage electrical power in order to maintain a safe temperature and the other is designed to activate an alarm in the event that the temperature should approach the freezing point of gallium. The circuit arrangement is shown in Drawing 253C951. Next the spacers, item 6, Drawing 4857D32, may be installed and the mounting plate, item 16, positioned onto them. This being done, the thermocouple plate and termination plug will be in approximate alignment with the mounting plate and should be moved into exact position and permanently fixed. The thermocouple reference junctions, item 9, Drawing 4857D32, should then be mounted onto the thermocouple reference junction mounting plate, item 13, and item 13 should then be mounted to item 16 by means of the spacers, item 12. The hermetic electrical receptacle, item 18, Drawing 4857D32, should then be wired according to the Wiring Diagram, Drawing 253C951. The wiring should be done with sufficient slack that the receptacle may later be pushed inward temporarily to allow the instrument housing, item 3, Drawing 4857D32, to be passed over the instrument package.

The assembly may next be removed from the bench assembly fixture and mounted in the crystal growing housing, item 1, Drawing 4857D32, with care being taken to align the keyway of the tube support sub-assembly with the key of the crystal growing housing. The instrument package housing may then be mounted flange-to-flange with the crystal housing. The assembly is completed by pulling the hermetic receptacle into its mounting hole and tightening the mounting nut.

The completed assembly, including the instrument package and ampoules, has a total weight of 8 pounds, 13 ounces.

IV. OPERATIONAL RESULTS

A. Power and Temperature Relationship

Power and temperature values as observed will vary somewhat from sample to sample because of small but unavoidable variations in ampoule dimensions and because the temperatures are measured at points lying within regions having considerable temperature gradients. In one typical experimental run, a constant power level of 31.5 watts for a given ampoule produced steady-state source-end and seed-end temperatures of 718°C and 488°C, respectively. The source-end thermocouple junction was located approximately 3/4 inch inward from the hot end of the ampoule and the seed-end thermocouple was located axially adjacent to the seed location. The source-end thermocouple was situated between the two quartz cups whereas the seed-end thermocouple was strapped directly against the ampoule by means of an insulated clamp, Drawing 861A149.

B. Voltage Requirement

The heating elements of the delivered apparatus have been designed to require 23 volts in order to consume approximately 89 watts which is necessary in order to provide the intended ampoule temperatures.

C. Heating and Cooling Rates

The rates of heating in the above-mentioned example are shown in Fig. 1 and the rates of cooling are shown in Fig. 2. All tests were

conducted in a bell jar with vacuum maintained at approximately 10^{-6} torr. The entire unit was mounted on a heat sink which was in turn mounted on a water-cooled post.

D. Crystal Growth

A number of experiments have been conducted utilizing the ampoule as described above with a nichrome heating element as well as an ampoule without a spiral but using a vertical two-zone furnace as a heat source.

In most cases the temperature gradient was 700°C at the GaAs source end of the ampoule and 500° at the seed end. The furnace gradient was set so that the upper furnace controlled the source end of the ampoule.

The results obtained using the nichrome ribbon heat were the same as those obtained using the vertical two-zone furnace.

The early experiments were made using a polycrystalline seed and all the more recent experiments were made using single crystal seeds with the (111) orientation (gallium surface) facing the hot end of the ampoule or with the $(\bar{1}\bar{1}\bar{1})$ orientation (arsenic surface) facing the hot end of the ampoule. Although the number of experiments performed has not been large, considering the variables which have been changed, we feel we can make certain conclusive statements, and certain other statements that seem reasonable, but are not verified.

The first conclusive statement is that GaAs has been grown by solution growth in a thermal gradient using the techniques outlined in this report. The GaAs crystals grown in these experiments were:

1. epitaxial on the $(\bar{1}\bar{1}\bar{1})$ surface (the arsenic surface)
of the GaAs seeds
2. non-epitaxial on the (111) surface (the gallium surface)

of the GaAs seeds

3. self-nucleated GaAs nucleated on the quartz wall of the ampoule and on the seed.

Most of the experiments were conducted for 100 hours, however, the last two experiments were run for 200 hours. There was significantly more epitaxial growth on the 200 hour experiments than on the 100 hour experiments, confirming that the amount of epitaxial growth is a function of time.

The self-nucleated growth also is a function of time. Crystallites approximately 2 mm cubed were quite common, 3 mm cubed were not unusual, and some 4 mm cubed crystallites were obtained. A difference between a 100 hour experiment and a 200 hour experiment was the number of 3 and 4 mm cubed crystallites were greater for the longer runs.

In all experiments there was obvious attack on the surface facing the cold end of the ampoule. The attack on this surface is most probably explained by solute transport from the seed through the solution to the coldest portion of the ampoule. This volume between the seed and the coldest portion of the ingot (about 1 cm long) contains a convection cell in which the cold surface of the seed acts as a source of solute and the coldest end of the ampoule acts as a nucleation site.

Since heat is flowing from the hotter portion of the solution in front of the seed to the cooler portion in back of the seed, one might expect an attack at some portion of the seed to reduce the impediment to heat flow: the seed would have a much lower thermal conductivity than the liquid solution. In all experiments a hole developed in the seed

which encompassed between 10-30% of the growing surface. It was noted that this hole developed next to one of the fingers of the plug and fingers. The reason for this is not completely understood.

There is also a definite difference in the observed growth on a (111) surface (the gallium face), and the ($\bar{1}\bar{1}\bar{1}$) surface (the arsenic face). Very little growth was even observed on the (111) surface and this material was non-epitaxial and usually could be scraped off easily. However, the growth on the ($\bar{1}\bar{1}\bar{1}$) surface was usually epitaxial and often smooth and shiny. We have not achieved uniform growth over the entire surface of the seed, but this may be due to convection currents causing temperature and solute concentration differences over the surface.

A note should be made here concerning the non-growth on the (111) or gallium surface. In the case of GaP, GaAs and also in the case of II-VI compounds (including CdS) we have observed that when self-nucleated crystals are grown from metallic solutions one face (the (111) surface) is usually smooth and planar, whereas the opposite side of the crystal has steps, other epitaxial crystals and even exhibits hopper growth.

This observation together with the observation of the difference in growth on a (111) surface and a ($\bar{1}\bar{1}\bar{1}$) surface in these ampoule experiments would indicate that the (111) surface is a very slow growing surface compared to the ($\bar{1}\bar{1}\bar{1}$) surface. It is possible that the crystal energy of the (111) surface subjected to a gallium environment is so different from that of the ($\bar{1}\bar{1}\bar{1}$) surface subjected to a gallium environment, that growth under the near equilibrium conditions of solution growth does not take place on this (111) surface. There may be another explanation for this observation of the difference in growth on a (111) surface and a ($\bar{1}\bar{1}\bar{1}$) surface. The (111) surface when polished gave a mirror like surface and the ($\bar{1}\bar{1}\bar{1}$) surface gave a matte finished surface (see bottom of page 11 and top of

page 12, toward the end of III, A, 1). Growth on a matte surface would present many re-entrant angles for growth to be initiated whereas a very smooth polished surface would not present many re-entrant angles.

V. CONCLUSIONS AND RECOMMENDATIONS

This report and the accompanying hardware comprise an operational unit including details of assembly and operation. The crystal growth ampoules include single crystal seeds, two of which have a $(\bar{1}\bar{1}\bar{1})$ surface and one with a (100) face.

As a result of experiments done in this apparatus at one gravity, it is clear that although convection currents have been greatly reduced in our mode of operation, convection does exist. As a result interpretation of the results obtained is not clear cut. Among the points that can be resolved by growth under zero gravity conditions are the surface finish of grown crystal and the effect of convection, the rate of heat and solute transfer unaided by convection, the rate and mechanism of seed dissolution in the cold portion of the ampoule, and the effect on growth of both self-nucleated and seeded crystals in a convectionless environment. Although definitive answers cannot be expected in a single experiment, much valuable information on the way crystals grow and how more perfect crystals can be made can be expected.

This project up to this time presents a versatile package for a number of different types of solution growth which can be carried out within the present limitations of power and temperature. Not only can GaAs be grown from gallium, but GaAs could be grown from other metallic solvents such as tin, indium, bismuth, and lead. All of the II-VI compounds of zinc and cadmium could be grown not only from their parent metallic

element but also from tin, lead, bismuth, gallium and indium. There is no reason even more complicated crystals couldn't be grown, such as solid solutions of III-V compounds, ternary compounds, such as ZnSnP_2 and even heterojunctions such as CdS on ZnSe. Indeed, without extensive modification, experiments in directional solidification of materials having moderate melting points can be performed.

ROUTING	FIREPROOF VAULT					

DRAWING LIST

INDEX	LINE	TITLE OF DRAWING	DRAWING NO.	MULTI-PLIER	ITEMS OR STYLE NO.	CHECKED	DATE CHECKED
	1	Spacer Pin	859A780				
	2	Housing Cap Detail	859A781				
	3	Enclosure Cap Detail	859A782				
	4	Flange Detail	859A804				
	5	Cap Detail	859A806				
	6	Key Detail	859A833				
	7	Heat Shield Detail	859A834				
	8	Support Rod Detail	859A835				
	9	Guide Detail	859A982				
	10	Stop Detail	859A983				
	11	Captive Screw Det	860A130				
	12	Captive Washer	860A131				
	13	Det	860A235				
	14	Plug Detail	860A250				
	15	Body Detail	861A024				
	16	Socket Detail	861A025				
	17	Nozzle Detail	861A026				
	18	Spacer Detail	861A027				
	19	Spacer Detail	861A028				
	20	Cap Detail	861A029				
	21	Plug Detail	861A030				
	22	Mounting Plate	861A031				
	23	Quartz Disk	861A032				
	24	Plate Detail	861A047				
	25	Insul Cap Detail	721B919				
	26	Thermal Cap Detail	721B920				
	27	Spacer Detail	721B921				
	28	Alignment Tube Detail	721B922				
	29	Split Tube Detail	721B926				

STOCK ORDER (1ST S.O. ON WHICH INF. HAS BEEN SENT TO SHOP) IDENTIFYING DATA: IN SPECIFYING THIS D NO. ON A STOCK ORDER THE ENGINEER MUST GIVE: -

NAME OF APPARATUS **Zero Gravity Crystal Growing**

C.S. Duncan-Engineer

CHECKED BY AND DATE H. Ryden 2-19-70	SUB. LETTER A	SUB. LETTER	SUB. LETTER	SUB. LETTER	SUB. LETTER
DESIGN SPEC. D 763614 (NASA)	SUB. LETTER	SUB. LETTER	SUB. LETTER	SUB. LETTER	SUB. LETTER

WESTINGHOUSE FORM 6541 J

PAGE **4**
OF **5**

ROUTING	FI EPROOF VAULT				

DRAWING LIST

INDEX	LINE	TITLE OF DRAWING	DRAWING NO.	MULTI-PLIER	ITEMS OR STYLE NO.	CHECKED	DATE CHECKED
	1	Housing Detail	721B928				
	2	Tube Enclosure Detail	721B932				
	3	Front Tube Sup Detail	721B940				
	4	Rear Tube Sup Detail	721B941				
	5	Tube Support Sub Ass'y	721B942				
	6	Flange Detail	721B948				
	7	Alignment PL Detail	721B952				
	8	Heat Shield Sub Assembly	721B960				
	9	Alignment Tube Det	722B004				
	10	Alignment R Det	722B005				
	11	Flange Detail	722B061				
	12	Quartz Tube Ass'y	722B216				
	13	Base Detail	722B238				
	14	Mounting Plate	722B239				
	15	Quartz Tube Detail	253C438				
	16	Housing Sub Assembly	253C464				
	17	Alignment PL Sub Ass'y	253C465				
	18	Quartz Capsule Sub Ass'y	253C466				
	19	Fixture Ass'y	253C505				
	20	Base Plate Detail	253C506				
	21						
	22	General Assembly	4857D32				
	23	Thermocouple Clamp	861A149				
	24	Wiring Diagram	253C951				
	25						
	26						
	27						
	28						
	29						

STOCK ORDER (1ST S.O. ON WHICH INF. HAS BEEN SENT TO SHOP) IDENTIFYING DATA: IN SPECIFYING THIS D NO. ON A STOCK ORDER THE ENGINEER MUST GIVE: —

NAME OF APPARATUS **Zero Gravity Crystal Growing**

CHECKED BY AND DATE	H. Ryden	2-19-70				
DESIGN SPEC.	D	763614 (NASA)	SUB. LETTER	SUB. LETTER	SUB. LETTER	SUB. LETTER
			A			
WESTINGHOUSE FORM 6541 J	PAGE 5	OF 5	SUB. LETTER	SUB. LETTER	SUB. LETTER	SUB. LETTER

SUB. S.O.	D.763614				
1	8-11 1969	C.W.L.	CSD		

WESTINGHOUSE ELECTRIC CORPORATION RESEARCH LABORATORIES CHURCHILL BORO. PITTSBURGH 35. PA., U.S.A.

TITLE ZERO GRAVITY CRYSTAL GROWING
SPACER PIN DETAIL

DWG. A SUB. 1 FINISH CHART

SYM.	ITEM	DESCRIPTION - MATERIAL DIMENSIONS IN INCHES	PAT. NO. OR REF. DWG.	FIN. CH. LINE NO.	STYLE NO.	SYM.					R & D		
						GR.	1	2	3	4	5	STK.	NO
	1	.50 OF. 125 DIA. SST. ROD	TYPE-304				1					35	20
	2	.43 OF. 125 DIA. SST. ROD	TYPE-304				1					35	20

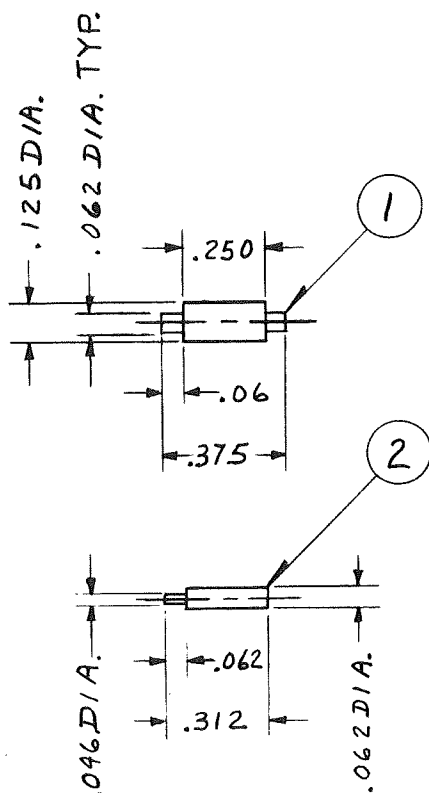

REF. DWG. 253C464

TOLERANCES		
UNLESS OTHERWISE SPECIFIED		
2 PL. DEC.	3 PL. DEC.	ANGLES
± .02	± .005	± 0.5°

859 A 780

SUB. S.O.	D-763619						
1	8-11 CWL						
	1943						
	25D						

WESTINGHOUSE ELECTRIC CORPORATION RESEARCH LABORATORIES CHURCHILL BORO. PITTSBURGH 35. PA., U.S.A.

TITLE ZERO GRAVITY CRYSTAL GROWING
HOUSING CAP DETAIL

DWG. A SUB. 1 FINISH CHART

SYM.	ITEM	DESCRIPTION - MATERIAL DIMENSIONS IN INCHES	PAT. NO. OR REF. DWG.	FIN. CH. LINE NO.	STYLE NO.	SYM.					R & D		
						GR.	1	2	3	4	5	STK.	No.
	1	4.25 x 4.25 OF .125 THK. SSH	SH. TYPE-304				1					37	04

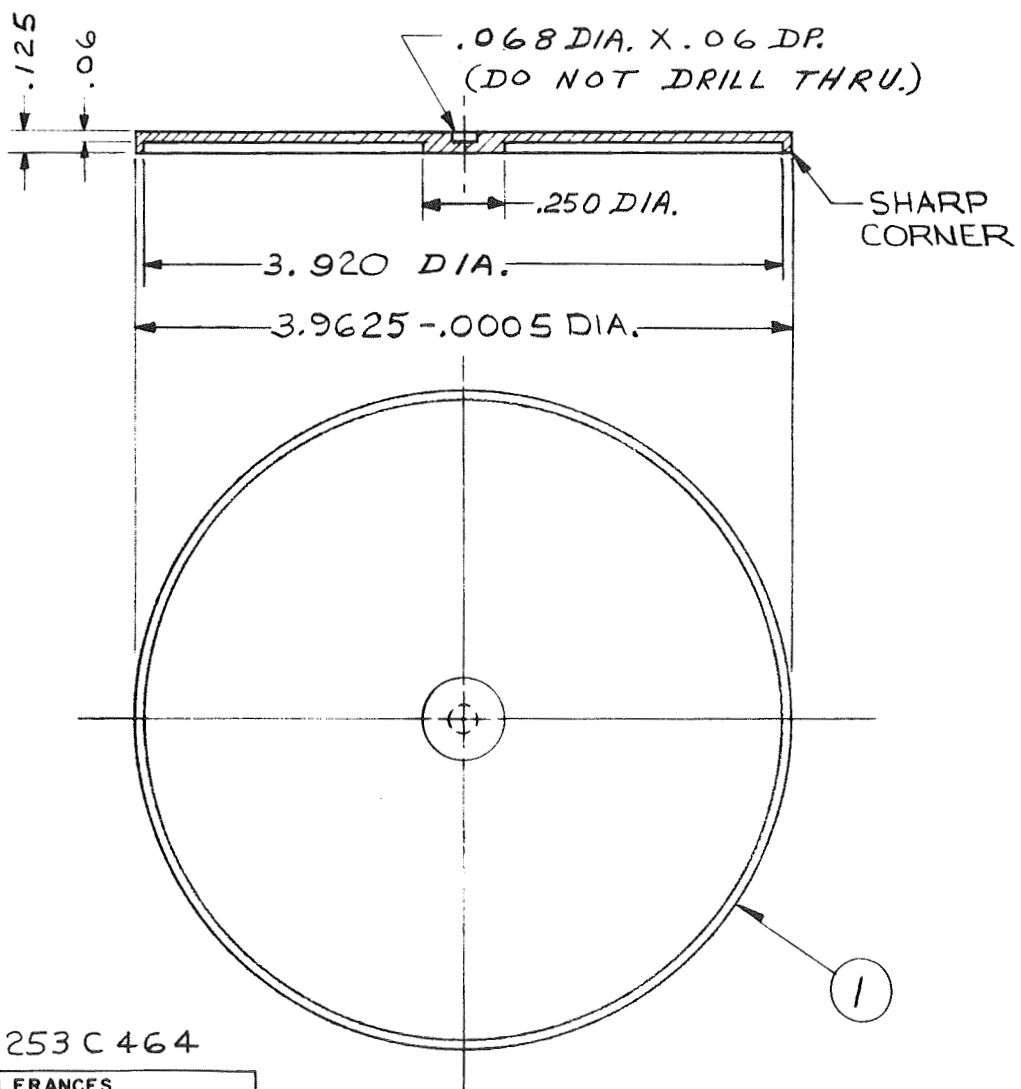

REF. DWG. 253 C 464

TOLERANCES		
UNLESS OTHERWISE SPECIFIED		
2 PL. DEC.	3 PL. DEC.	ANGLES
± .02	± .005	± 0.5°

859 A 781

SUB.	S.O.	D.763614						
1	8-11	CWL						
	263	05D						

WESTINGHOUSE ELECTRIC CORPORATION RESEARCH LABORATORIES CHURCHILL BORO. PITTSBURGH 35, PA., U.S.A.

TITLE ZERO GRAVITY CRYSTAL GROWING
ENCLOSURE CAP DETAIL

DWG. A SUB. 1 FINISH CHART

SYM.	ITEM	DESCRIPTION - MATERIAL DIMENSIONS IN INCHES	PAT. NO. OR REF. DWG.	FIN. CH. LINE NO.	STYLE NO.	SYM. GR.						R & D	
							1	2	3	4	5	STK	No.
1		3.500 DIA. OF .031 THK. SST. R. TYPE 304					1					37	00

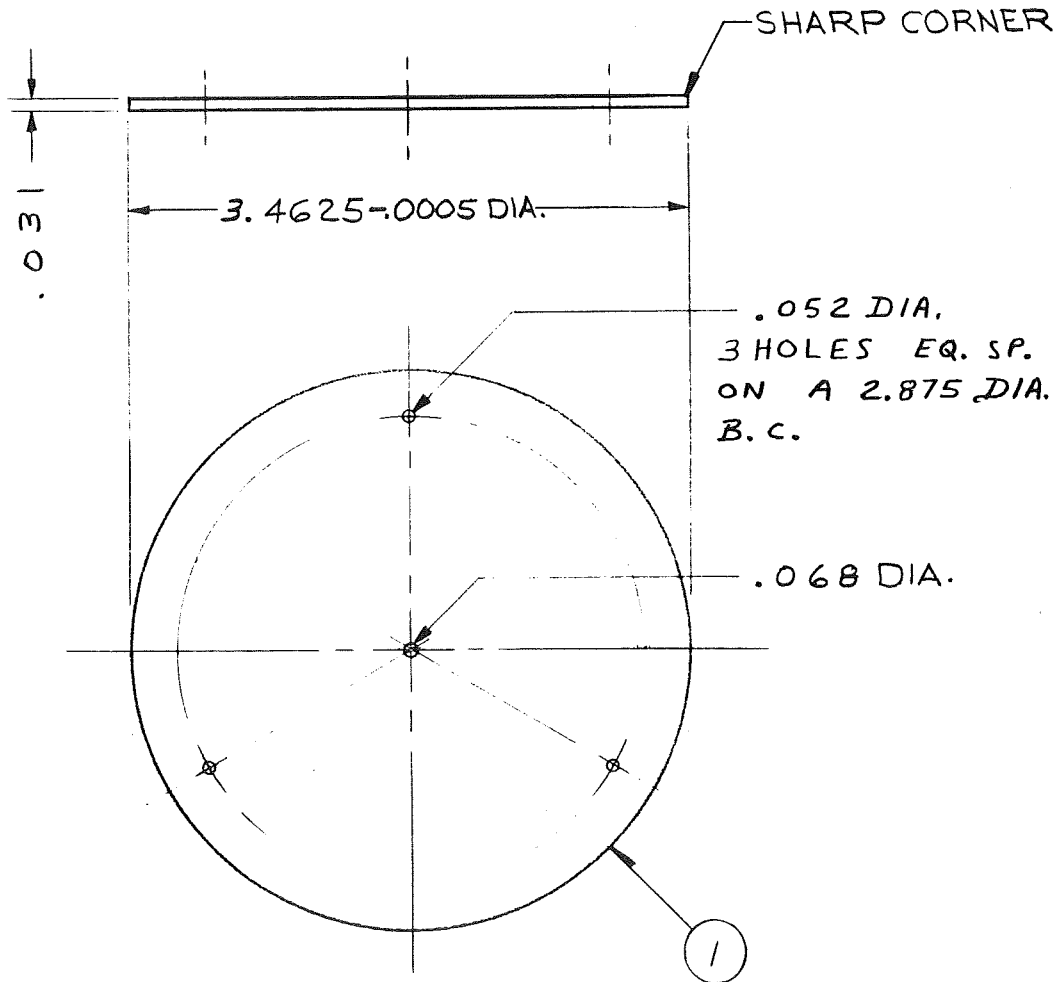

REF. DWG. 253C 464

TOLERANCES		
UNLESS OTHERWISE SPECIFIED		
2 PL. DEC.	3 PL. DEC.	ANGLES
± .02	± .005	± 0.5°

859A782

SUB. S.O.	D. 763614				
1	8-15 1961	CWL			
		0.50			

WESTINGHOUSE ELECTRIC CORPORATION RESEARCH LABORATORIES CHURCHILL BORO. PITTSBURGH 35. PA., U.S.A.

TITLE ZERO GRAVITY CRYSTAL GROWING
FLANGE DETAIL

DWG. A SUB. 1 FINISH CHART

SYM.	ITEM	DESCRIPTION — MATERIAL DIMENSIONS IN INCHES	PAT. NO. OR REF. DWG.	FIN. CH. LINE NO.	STYLE NO.	SYM.					R & D STK. NO.	
						GR.	1	2	3	4		5
	1	4.25 X 4.25 OF .50 THK.	304 SST. PLATE.				1					3709

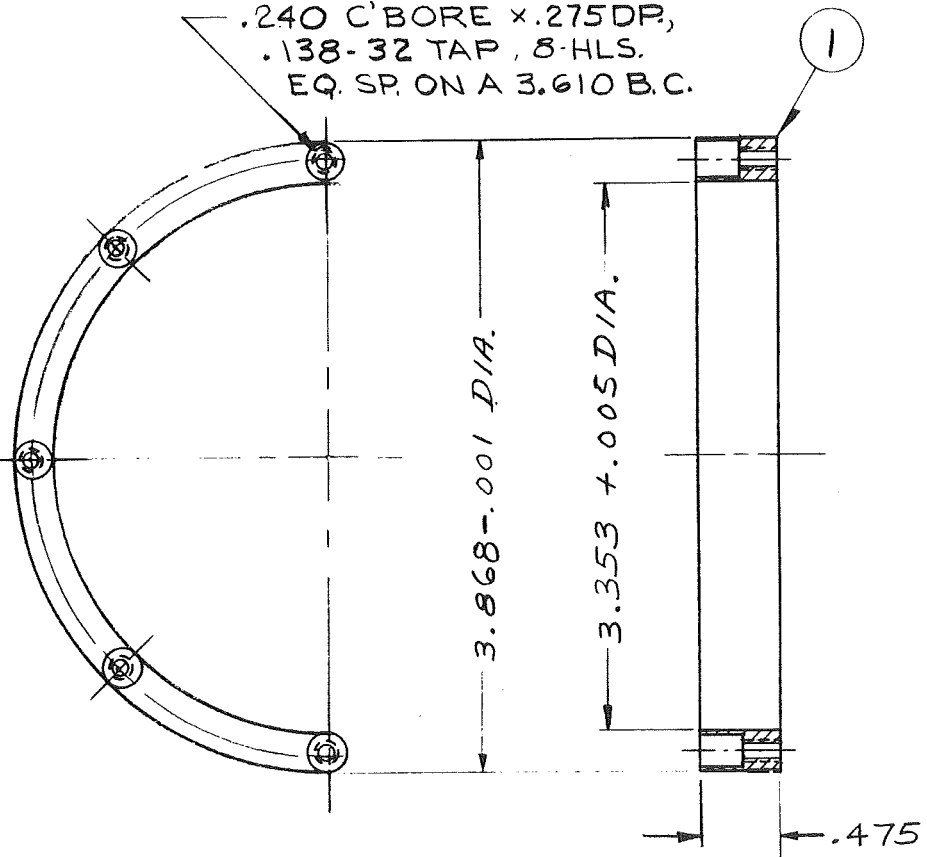

REF. DWG. 253C 464

TOLERANCES		
UNLESS OTHERWISE SPECIFIED		
2 PL. DEC.	3 PL. DEC.	ANGLES
± .02	± .005	± 0.5°

859A804

SUB.	S.O.					
1	D.763614					
B-15	CWL					
	CSD					

WESTINGHOUSE ELECTRIC CORPORATION RESEARCH LABORATORIES CHURCHILL BORO, PITTSBURGH 35, PA., U.S.A.

TITLE ZERO GRAVITY CRYSTAL GROWING
CAP DETAIL

DWG. A SUB. 1 FINISH CHART

SYM.	ITEM	DESCRIPTION - MATERIAL DIMENSIONS IN INCHES	PAT. NO. OR REF. DWG.	FIN. CH. LINE NO.	STYLE NO.	SYM. GR.						R & D		
							1	2	3	4	5	STK.	NO.	
	1	.250 OF 1.375 DIA. SST. ROD TYPE 304					1						35	37
*	2	4.25 OF .375 DIA. NICKEL ROD					1							

* ITEM 2 TO BE CUT TO SUITABLE LENGTH

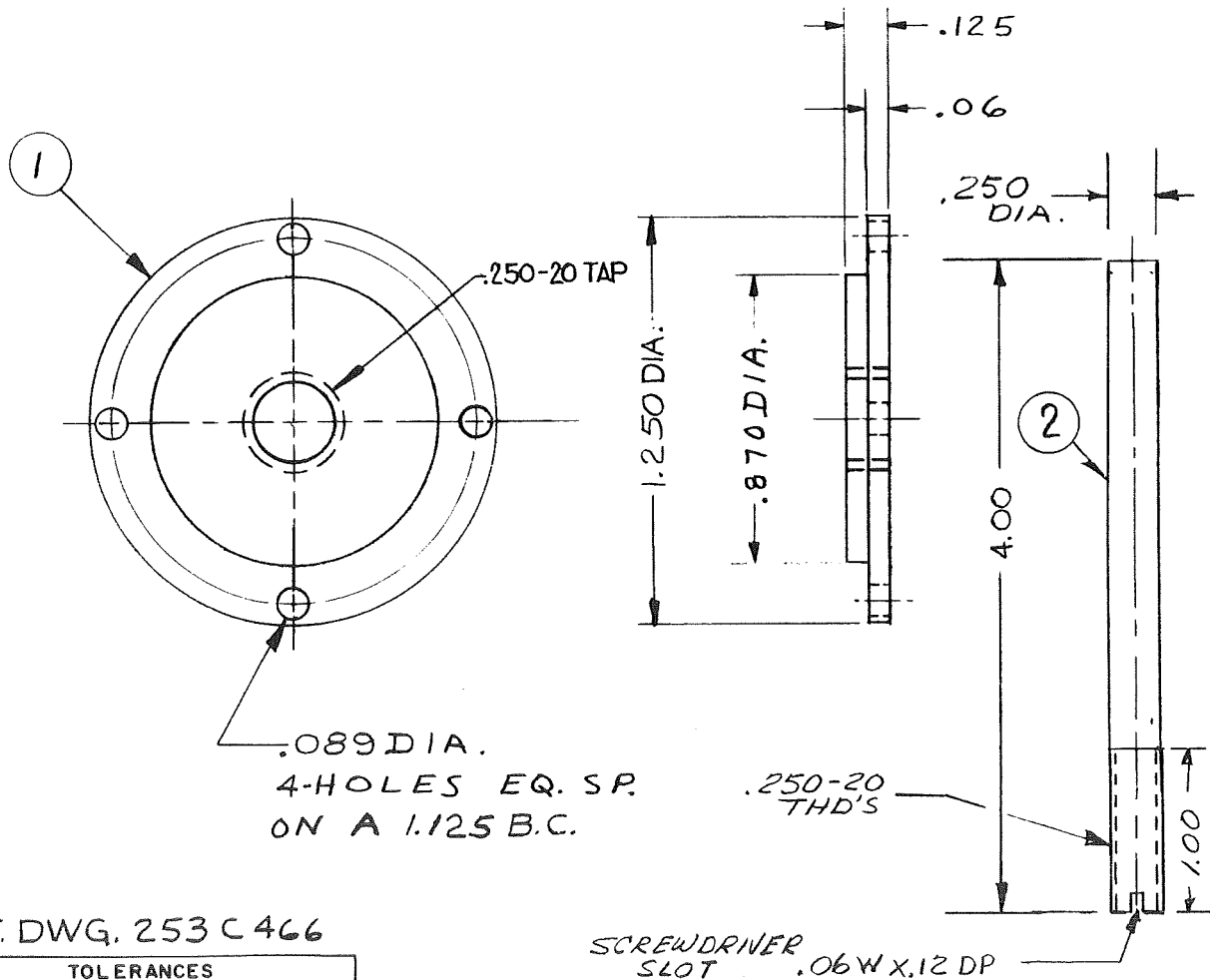

REF. DWG. 253 C 466

TOLERANCES		
UNLESS OTHERWISE SPECIFIED		
2 PL. DEC.	3 PL. DEC.	ANGLES
± .02	± .005	± 0.5°

SCREWDRIVER
SLOT .06W X .12 DP

859A806

SUB.	S.O.				
1	D763614				
6-19-62	W.C.S.				
	03D				

WESTINGHOUSE ELECTRIC CORPORATION RESEARCH LABORATORIES CHURCHILL BORO. PITTSBURGH 35. PA., U.S.A.

TITLE ZERO GRAVITY CRYSTAL GROWING
KEY DETAIL

DWG. A SUB. 1 FINISH CHART

SYM.	ITEM	DESCRIPTION - MATERIAL DIMENSIONS IN INCHES	PAT. NO. OR REF. DWG.	FIN. CH. LINE NO.	STYLE NO.	SYM.					R&D STK. NO.	D. NO.	
						GR.	1	2	3	4			5
	1	4.875 OF .125 THK. SST. PL. TYPE 304					1					37	04

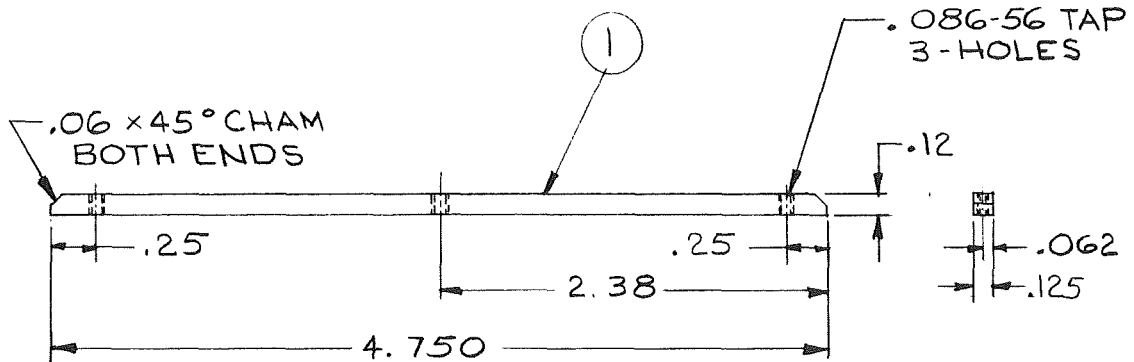

REF. DWG 253C464

TOLERANCES		
UNLESS OTHERWISE SPECIFIED		
2 PL. DEC.	3 PL. DEC.	ANGLES
±.02	±.005	±0.5°

859 A 833

SUB. S.O.	1	D.763614							
	819	W.C.S.	CSD						

WESTINGHOUSE ELECTRIC CORPORATION RESEARCH LABORATORIES CHURCHILL BORO. PITTSBURGH 35, PA., U.S.A.

TITLE ZERO GRAVITY CRYSTAL GROWING
HEAT SHIELD DETAIL

DWG. A SUB. 1 FINISH CHART

SYM.	ITEM	DESCRIPTION - MATERIAL DIMENSIONS IN INCHES	PAT. NO. OR REF. DWG.	FIN. CH. LINE NO.	STYLE NO.	SYM.					R. & D. STK. NO.	
						GR.	1	2	3	4		5
	1	3.343 DIA. OF .03 THK. S.S. PL. TYP. 304					1					37 02

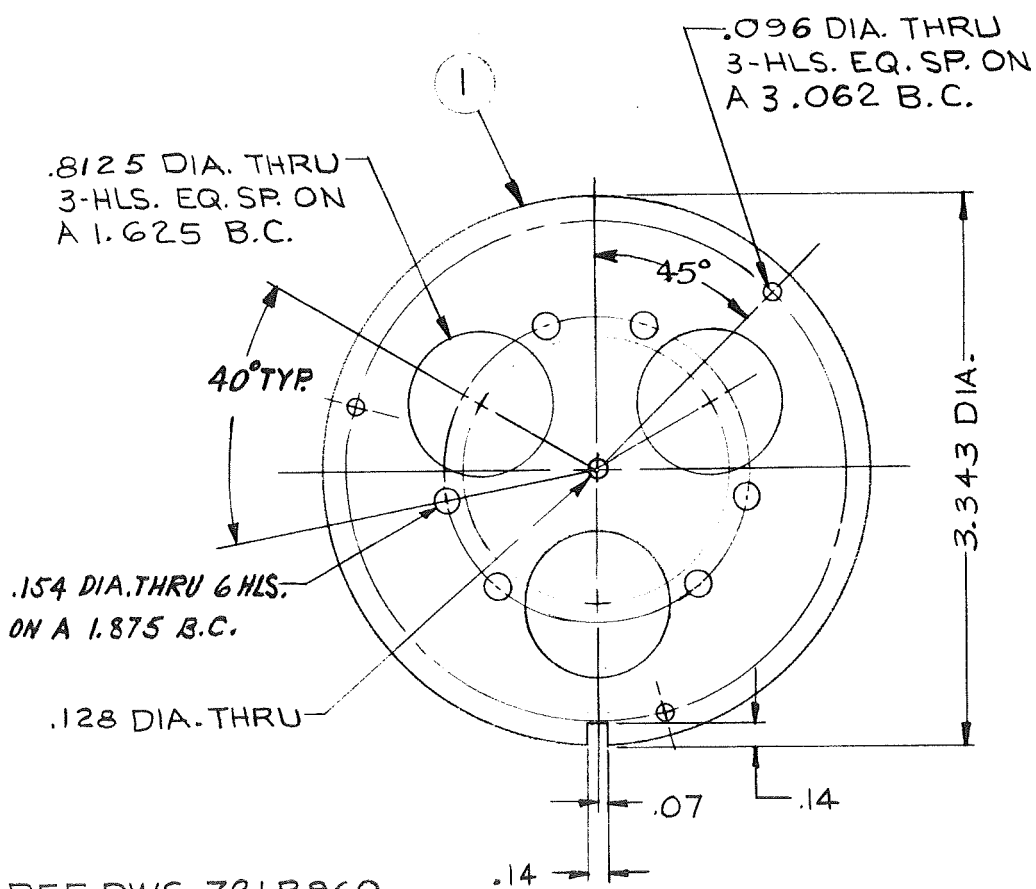

REF. DWG. 721B960

TOLERANCES		
UNLESS OTHERWISE SPECIFIED		
2 PL. DEC.	3 PL. DEC.	ANGLES
± .02	± .005	± 0.5°

859 A834

SUB. S.O.	1	D763614	L. CAROTHERS					
-----------	---	---------	--------------	--	--	--	--	--

WESTINGHOUSE ELECTRIC CORPORATION RESEARCH LABORATORIES CHURCHILL BORO. PITTSBURGH 35. PA., U.S.A.

TITLE ZERO GRAVITY CRYSTAL GROWING
SUPPORT ROD DETAIL

DWG. 859A835 SUB. 1

FINISH CHART

SYM.	ITEM	DESCRIPTION - MATERIAL DIMENSIONS IN INCHES	PAT. NO. OR REF. DWG.	FIN. CH. LINE NO.	STYLE NO.	SYM.					R	D	
						GR.	1	2	3	4			5
	1	4.03 OF .125 DIA. S.S.T. ROD TYPE 304					1					35	20

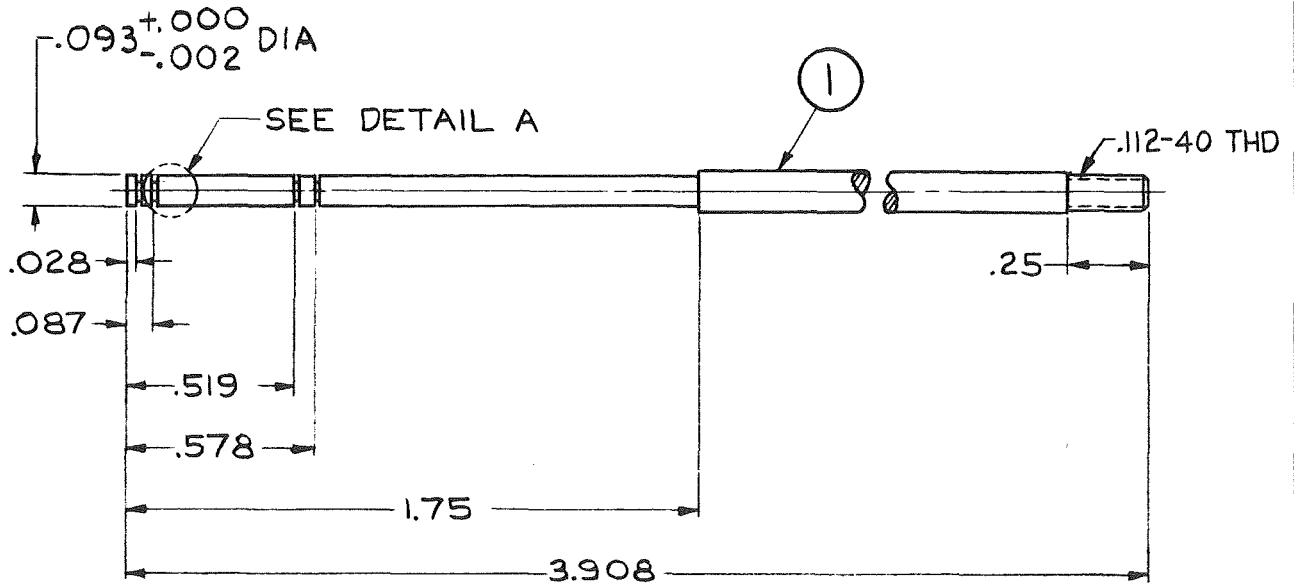
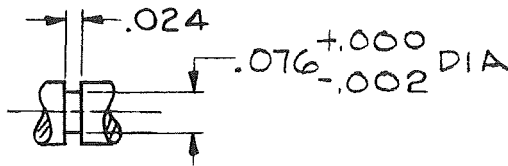

REF. DWG. 721B960

TOLERANCES		
UNLESS OTHERWISE SPECIFIED		
2 PL. DEC.	3 PL. DEC.	ANGLES
± .02	± .005	± 0.5°

859A835

SUB.	1					
S.O.	D763614	W.C.S.				
	0.4-					
	69					

WESTINGHOUSE ELECTRIC CORPORATION RESEARCH LABORATORIES CHURCHILL BORO. PITTSBURGH 35, PA., U.S.A.

TITLE ZERO GRAVITY CRYSTAL GROWING
GUIDE DETAIL

DWG. A SUB. 1 FINISH CHART

SYM.	ITEM	DESCRIPTION - MATERIAL DIMENSIONS IN INCHES	PAT. NO. OR REF. DWG.	FIN. CH. LINE NO.	STYLE NO.	SYM.					R E D STK No.	No.	
						GR.	1	2	3	4			5
	1	4.12 OF .12 SQ SST BAR TYPE		303			1					34	50

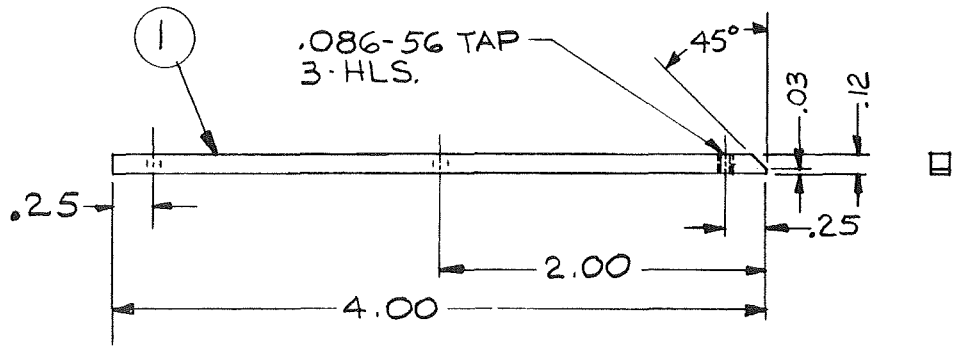

REF. DWG. 253C505

TOLERANCES		
UNLESS OTHERWISE SPECIFIED		
2 PL. DEC.	3 PL. DEC.	ANGLES
±.02	±.005	±0.5°

859A982

SUB. S.O.	1	0763614					
	9-25	W.C.S.					
	49	CSJ					

WESTINGHOUSE ELECTRIC CORPORATION RESEARCH LABORATORIES CHURCHILL BORO. PITTSBURGH 35, PA., U.S.A.

TITLE ZERO GRAVITY CRYSTAL GROWING
CAPTIVE SCREW DETAIL

DWG. A SUB. 1 FINISH CHART

SYM.	ITEM	DESCRIPTION - MATERIAL DIMENSIONS IN INCHES	PAT. NO. OR REF. DWG.	FIN. CH. LINE NO.	STYLE NO.	SYM.					R & D STK.	D NO.
						GR.	1	2	3	4		
	1	.138-32 X .50 LG. HEX. HD. CAP SCR. SST.					1					36-08-1408
	2	.190-32 X .50 LG. HEX. HD. CAP SCR. SST.					1					36-08-2420

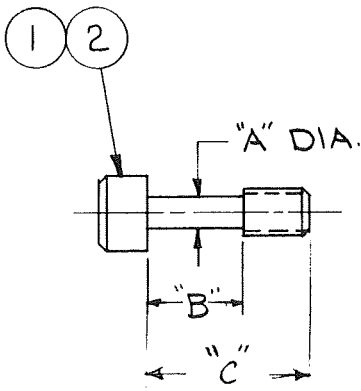

IT. NO.	"A"	"B"	"C"
1	.098	.312	.500
2	.125	.300	.4375

REF. DWG. 4857D32

TOLERANCES		
UNLESS OTHERWISE SPECIFIED		
2 PL. DEC.	3 PL. DEC.	ANGLES
±.02	±.005	±0.5°

860 A 130

SUB.	1	D.763614				
S.O.	9.25	W.C.S.				
	6.2					

WESTINGHOUSE ELECTRIC CORPORATION RESEARCH LABORATORIES CHURCHILL BORO. PITTSBURGH 35. PA.. U.S.A.

TITLE ZERO GRAVITY CRYSTAL GROWING
CAPTIVE WASHER DETAIL

DWG. A SUB. 1 FINISH CHART

SYM.	ITEM	DESCRIPTION - MATERIAL DIMENSIONS IN INCHES	PAT. NO. OR REF. DWG.	FIN. CH. LINE NO.	STYLE NO.	SYM. GR.						R & D STK NO.
							1	2	3	4	5	
	1	.112 FLAT WASHER S.S.T.					1					36-95-3440
	2	.164 FLAT WASHER S.S.T.					1					36-95-3480

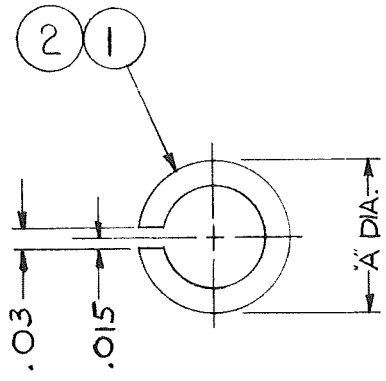

IT. NO.	"A"
1	.230
2	.312

REF. DWG. 4857 D 32

TOLERANCES		
UNLESS OTHERWISE SPECIFIED		
2 PL. DEC.	3 PL. DEC.	ANGLES
± .02	± .005	± 0.5°

860A131

SUB.	S.O.
1	D. 763614
	K. SCHERMM
	25D

WESTINGHOUSE ELECTRIC CORPORATION RESEARCH LABORATORIES CHURCHILL BORO. PITTSBURGH 35. PA., U.S.A.

TITLE ZERO GRAVITY CRYSTAL GROWING
DETAIL

DWG. 860 A 235 SUB. 1

FINISH CHART

SYM.	ITEM	DESCRIPTION - MATERIAL DIMENSIONS IN INCHES	PAT. NO. OR REF. DWG.	FIN. CH. LINE NO.	STYLE NO.	SYM.					R. & D. STOCK	
						GR.	1	2	3	4		5
	1	4.25 x 4.25 OF. 125 THK.	SST. SH. - TYPE		304		1					37 04

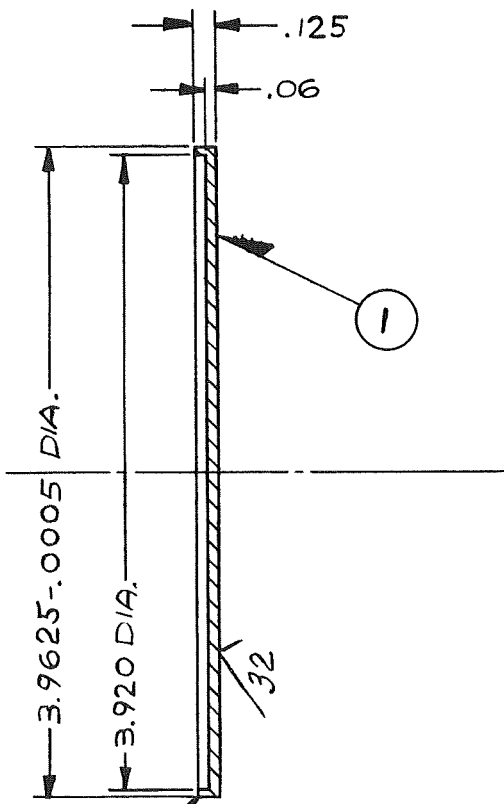

SHARP CORNER

TOLERANCES		
UNLESS OTHERWISE SPECIFIED		
2 PL. DEC.	3 PL. DEC.	ANGLES
± .02	± .005	± 0.5°

860 A 235

S.O.	D-763614				
SUB.	1	HR	ASD		

WESTINGHOUSE ELECTRIC CORPORATION RESEARCH LABORATORIES CHURCHILL BORO. PITTSBURGH 35, PA., U.S.A.

TITLE ZERO GRAVITY CRYSTAL GROWING
PLUG DETAIL

DWG. A SUB. 1 FINISH CHART _____

SYM.	ITEM	DESCRIPTION - MATERIAL DIMENSIONS IN INCHES	PAT. NO. OR REF. DWG.	FIN. CH. LINE NO.	STYLE NO.	SYM.					
						GR.	1	2	3	4	5
/		2.75 OF 12 MM O.D. x 8 MM I.D. QUARTZ TUBING				/					

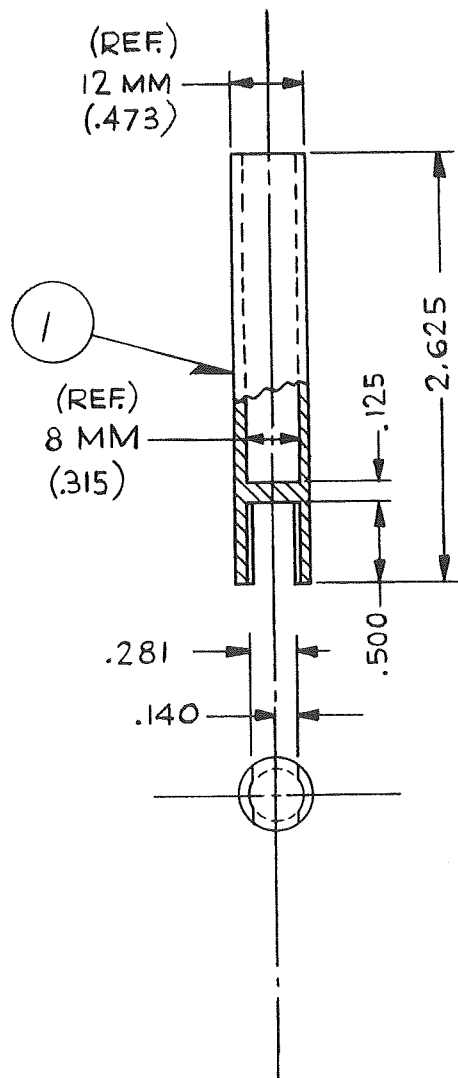

TOLERANCES		
UNLESS OTHERWISE SPECIFIED		
2 PL. DEC.	3 PL. DEC.	ANGLES
± .02	± .005	± 0.5°

860 A 250

SUB.	S.O.						
1	D.7636/14	AR	CSJ				

WESTINGHOUSE ELECTRIC CORPORATION RESEARCH LABORATORIES CHURCHILL BORO. PITTSBURGH 35, PA., U.S.A.

TITLE ZERO GRAVITY CRYSTAL GROWING
BODY DETAIL

DWG. **A** SUB. 1 FINISH CHART

SYM.	ITEM	DESCRIPTION - MATERIAL DIMENSIONS IN INCHES	PAT. NO. OR REF. DWG.	FIN. CH. LINE NO.	STYLE NO.	SYM.					R E D STK. NO.
						GR.	1	2	3	4	
	1	3.38 OF 4.000 O.D. X .120 WALL SST TUB #304				1					37 91

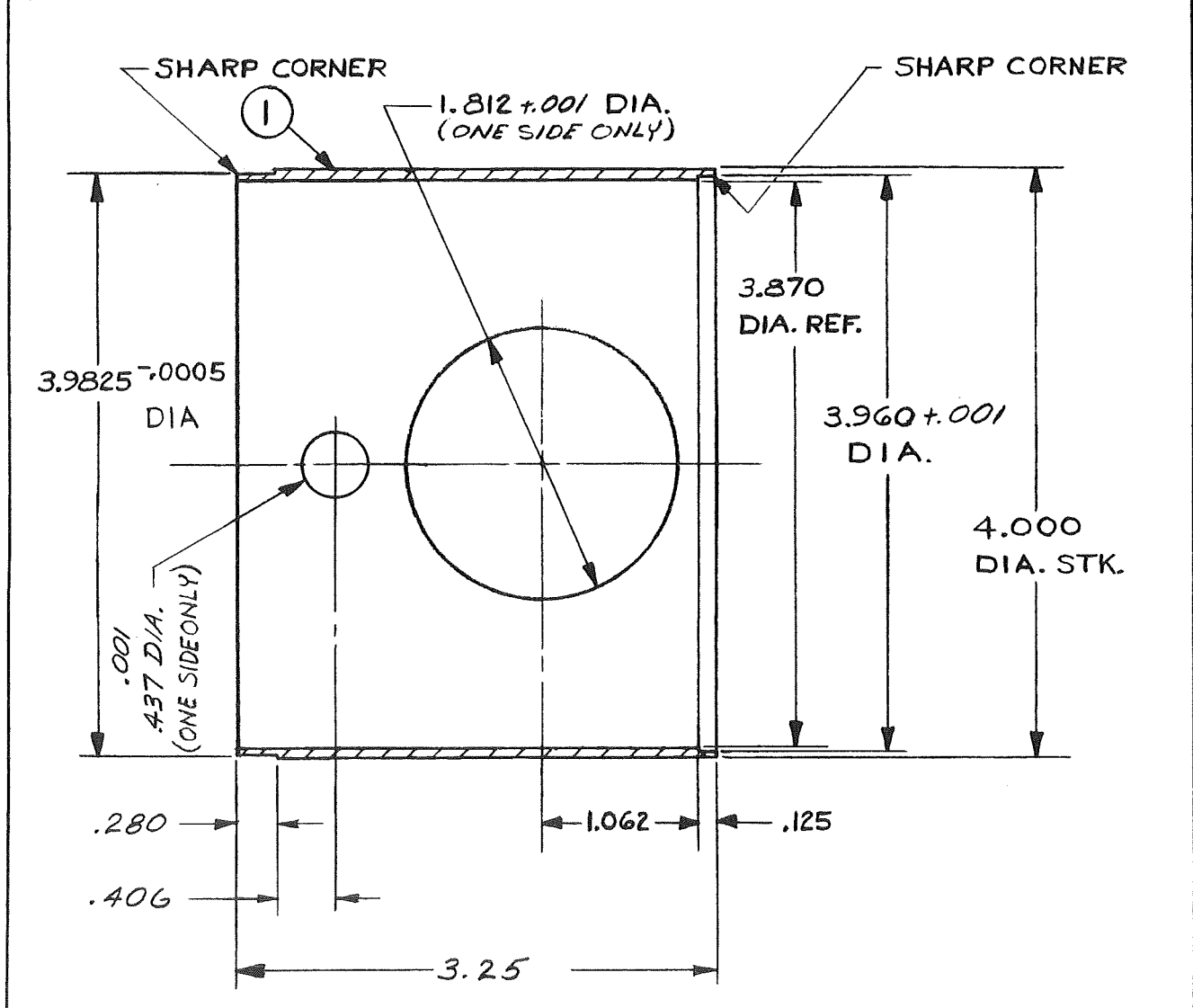

TOLERANCES		
UNLESS OTHERWISE SPECIFIED		
2 PL. DEC.	3 PL. DEC.	ANGLES
± .02	± .005	± 0.5°

861 A024

SUB.	S.O.						
1	D.76361A	HR	20D				

WESTINGHOUSE ELECTRIC CORPORATION RESEARCH LABORATORIES CHURCHILL BORO. PITTSBURGH 35. PA., U.S.A.

TITLE ZERO GRAVITY CRYSTAL GROWING
SOCKET DETAIL

DWG. A SUB. 1 FINISH CHART

SYM.	ITEM	DESCRIPTION - MATERIAL DIMENSIONS IN INCHES	PAT. NO. OR REF. DWG.	FIN. CH. LINE NO.	STYLE NO.	SYM.					R&D STK. NO.	
						GR.	1	2	3	4		5
	1	.50 OF 2.000 DIA. 55T. ROD #304					1					35 41

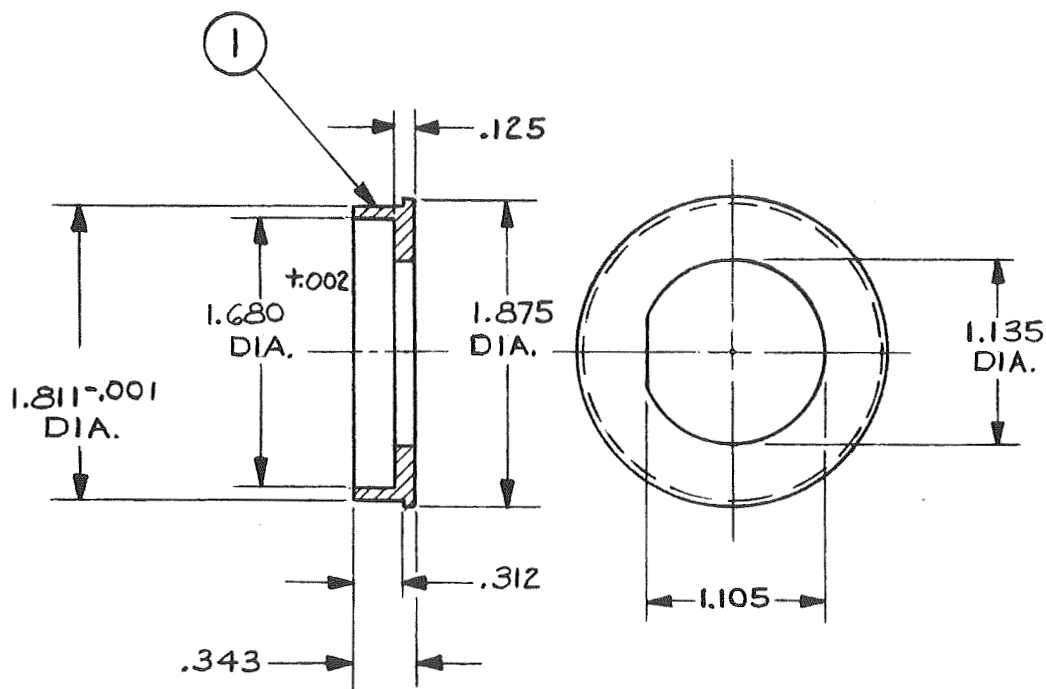

TOLERANCES		
UNLESS OTHERWISE SPECIFIED		
2 PL. DEC.	3 PL. DEC.	ANGLES
± .02	± .005	± 0.5°

861A025

S.O.	D.763614						
SUB.	1	HR	5-D				

WESTINGHOUSE ELECTRIC CORPORATION RESEARCH LABORATORIES CHURCHILL BORO, PITTSBURGH 35, PA., U.S.A.

TITLE ZERO GRAVITY CRYSTAL GROWING
NOZZEL DETAIL

DWG. A SUB. 1 FINISH CHART

SYM.	ITEM	DESCRIPTION - MATERIAL DIMENSIONS IN INCHES	PAT. NO. OR REF. DWG.	FIN. CH. LINE NO.	STYLE NO.	SYM.					RF STK.	D NO.	
						GR.	1	2	3	4			5
	1	1.38 OF .875 DIA. SST ROD # 304					1					35	32

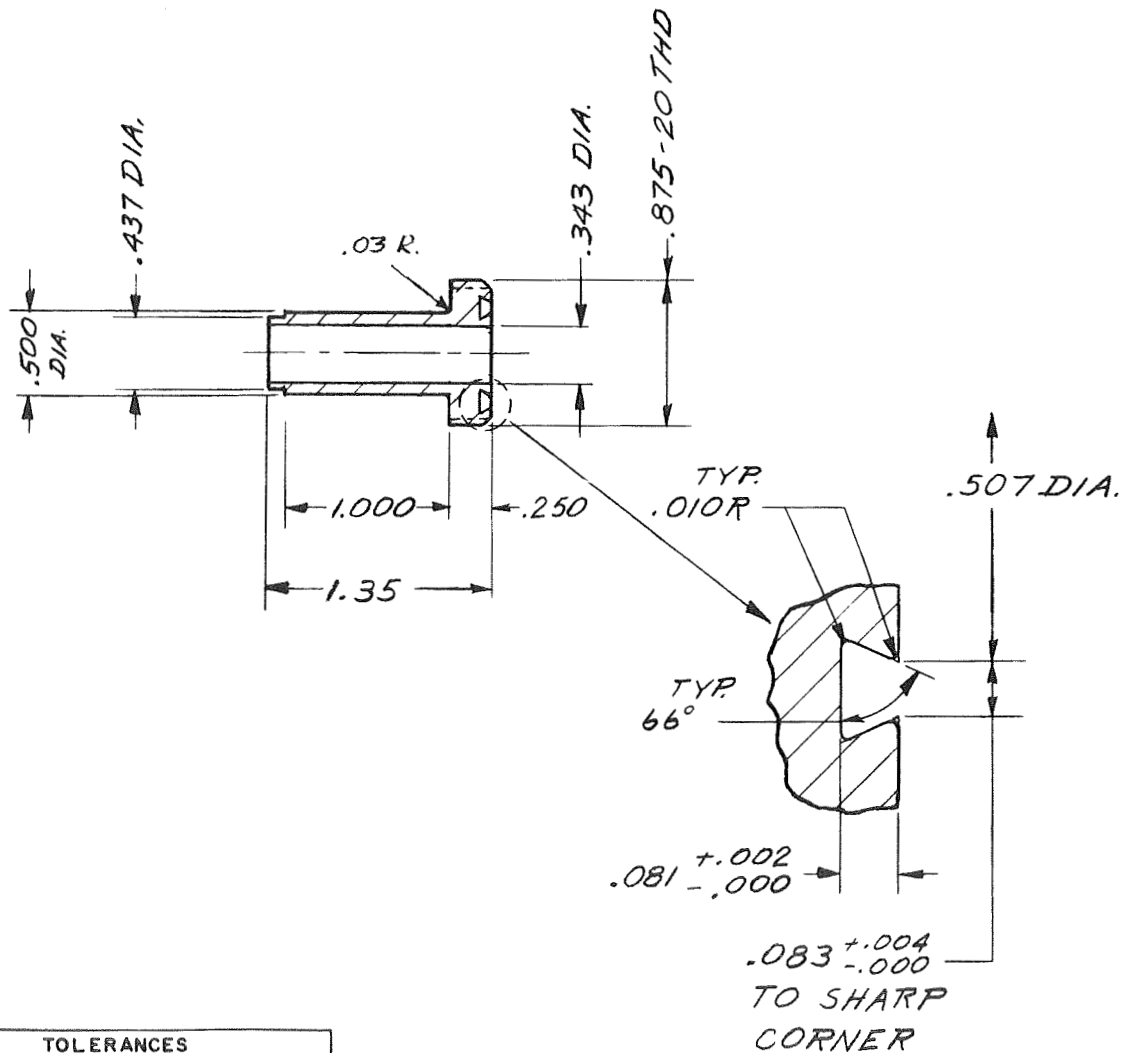

TOLERANCES		
UNLESS OTHERWISE SPECIFIED		
2 PL. DEC.	3 PL. DEC.	ANGLES
± .02	± .005	± 0.5°

861 A026

SUB.	S.O.							
1	D.763614	HR	1.25					

WESTINGHOUSE ELECTRIC CORPORATION RESEARCH LABORATORIES CHURCHILL BORO, PITTSBURGH 35, PA., U.S.A.

TITLE ZERO GRAVITY CRYSTAL GROWING
SPACER DETAIL

DWG. A SUB. 1

FINISH CHART

SYM.	ITEM	DESCRIPTION - MATERIAL DIMENSIONS IN INCHES	PAT. NO. OR REF. DWG.	FIN. CH. LINE NO.	STYLE NO.	SYM.					R&D		
						GR.	1	2	3	4	5	STK	NO
	1	1.50 OF .187 DIA SST ROD # 303					1					34	02

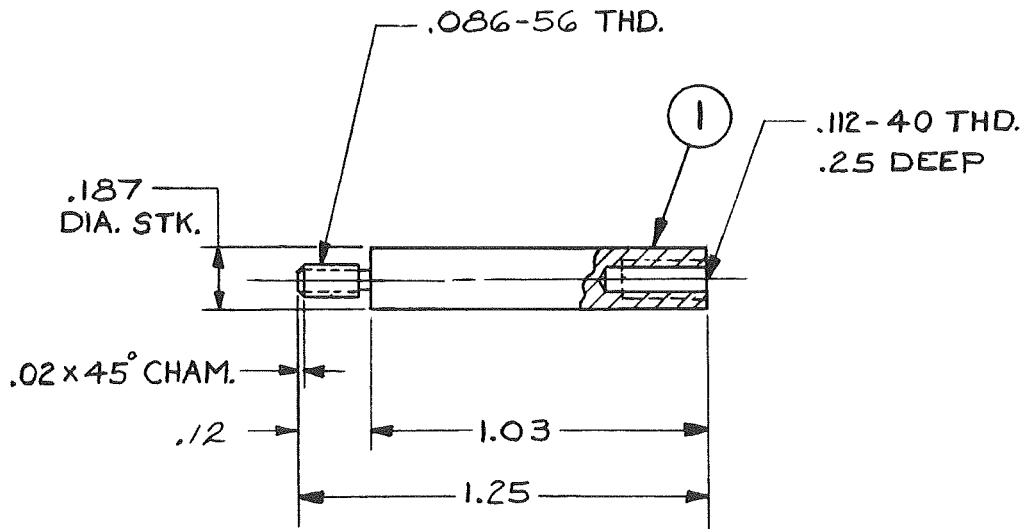

TOLERANCES		
UNLESS OTHERWISE SPECIFIED		
2 PL. DEC.	3 PL. DEC.	ANGLES
± .02	± .005	± 0.5°

861 A 027

SUB.	1						
S.O.	D.76361A	HR	CLK				

WESTINGHOUSE ELECTRIC CORPORATION RESEARCH LABORATORIES CHURCHILL BORO. PITTSBURGH 35, PA., U.S.A.

TITLE ZERO GRAVITY CRYSTAL GROWING
SPACER DETAIL

DWG. A SUB. 1 FINISH CHART

SYM.	ITEM	DESCRIPTION - MATERIAL DIMENSIONS IN INCHES	PAT. NO. OR REF. DWG.	FIN. CH. LINE NO.	STYLE NO.	SYM.					R & D STK. NO
						GR.	1	2	3	4	
	1	2.12 OF .187 DIA. S5T ROD.	#303			1					34 02

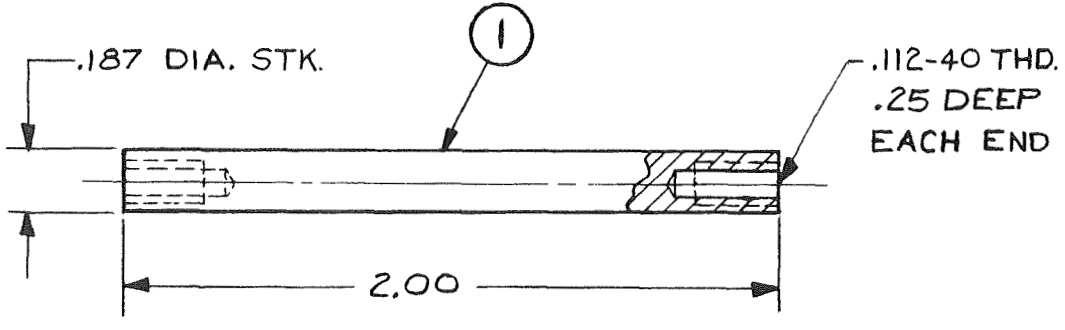

TOLERANCES		
UNLESS OTHERWISE SPECIFIED		
2 PL. DEC.	3 PL. DEC.	ANGLES
±.02	±.005	±0.5°

861A028

SUB.	S.O.						
1	D.763614	HR	CSO				

WESTINGHOUSE ELECTRIC CORPORATION RESEARCH LABORATORIES CHURCHILL BORO. PITTSBURGH 35, PA., U.S.A.

TITLE ZERO GRAVITY CRYSTAL GROWING
CAP DETAIL

DWG. A SUB. 1 FINISH CHART

SYM.	ITEM	DESCRIPTION - MATERIAL DIMENSIONS IN INCHES	PAT. NO. OR REF. DWG.	FIN. CH. LINE NO.	STYLE NO.	SYM.					R & D STK. NO.	
						GR.	1	2	3	4		5
	1	.62 OF 1.125 DIA SST ROD 303					1					34 16

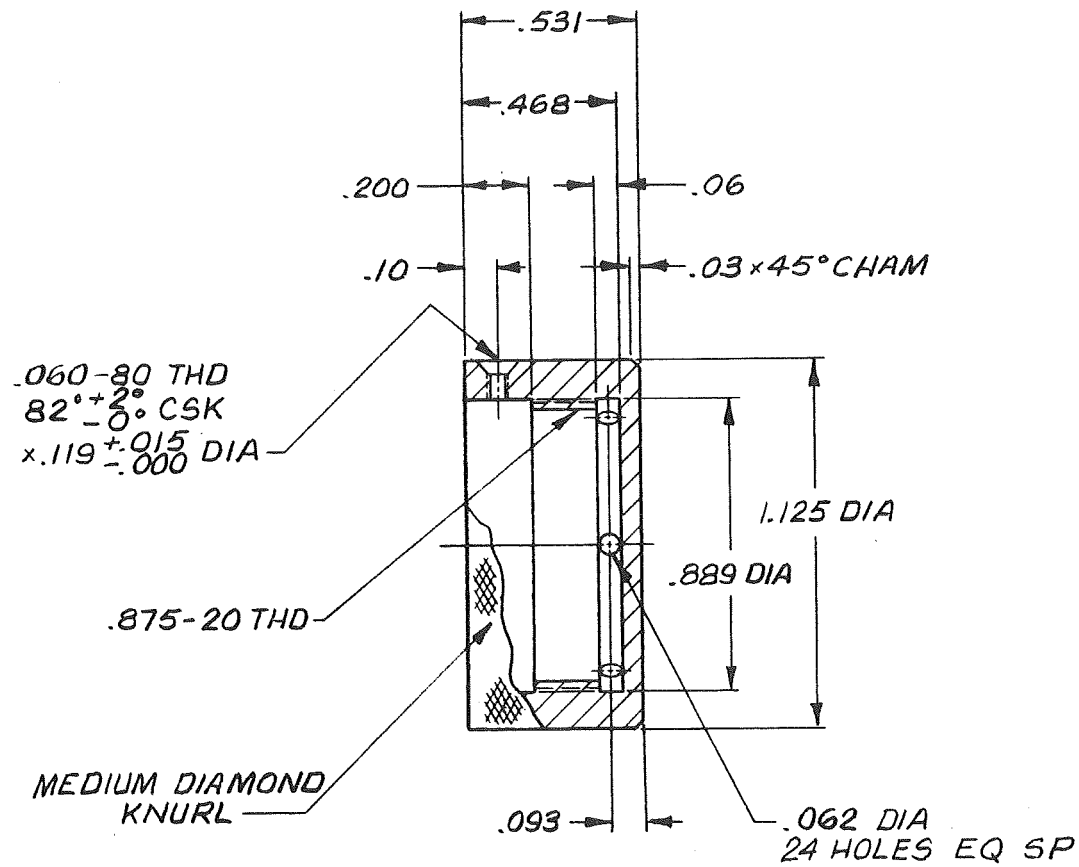

TOLERANCES		
UNLESS OTHERWISE SPECIFIED		
2 PL. DEC.	3 PL. DEC.	ANGLES
± .02	± .005	± 0.5°

861A029

SUB. S.O.	D. 763614	HR	1.0					
SUB. 1								

WESTINGHOUSE ELECTRIC CORPORATION RESEARCH LABORATORIES CHURCHILL BORO. PITTSBURGH 35, PA., U.S.A.

TITLE ZERO GRAVITY CRYSTAL GROWING
MOUNTING PLATE DETAIL

DWG. A SUB. 1 FINISH CHART

SYM. ITEM	DESCRIPTION - MATERIAL DIMENSIONS IN INCHES	PAT. NO. OR REF. DWG.	FIN. CH. LINE NO.	STYLE NO.	SYM. GR.						R&D STK NO.
						1	2	3	4	5	
1	4.0 X 4.0 OF .032 SST SH #304					1					37 00

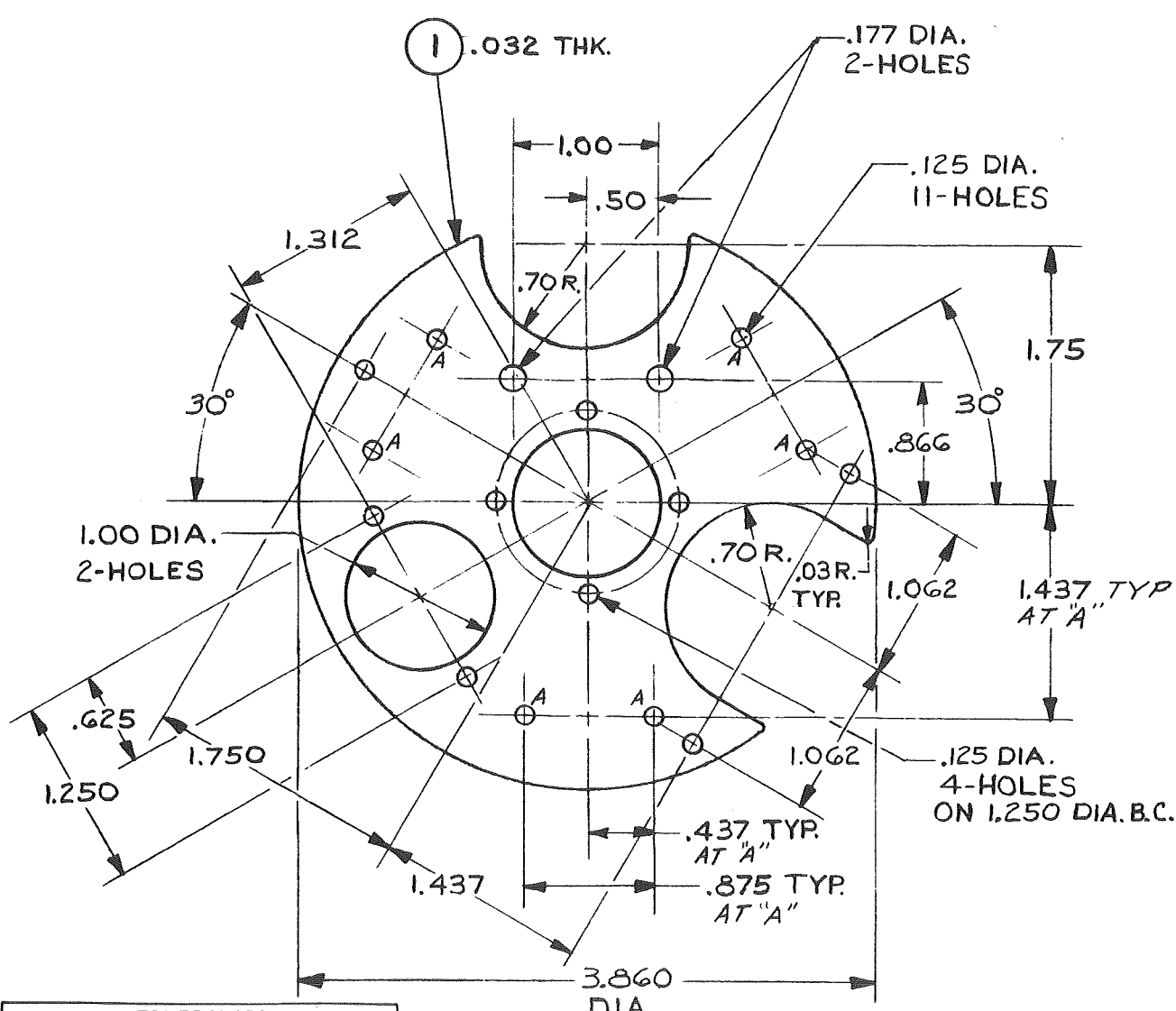

TOLERANCES		
UNLESS OTHERWISE SPECIFIED		
2 PL. DEC.	3 PL. DEC.	ANGLES
± .02	± .005	± 0.5°

861 A031

SUB.	S.O.								
1	D.763614	AR	WED						

WESTINGHOUSE ELECTRIC CORPORATION RESEARCH LABORATORIES CHURCHILL BORO, PITTSBURGH 35, PA., U.S.A.

TITLE QUARTZ DISK

DWG. A SUB. 1 FINISH CHART _____

SYM.	ITEM	DESCRIPTION — MATERIAL DIMENSIONS IN INCHES	PAT. NO. OR REF. DWG.	FIN. CH. LINE NO.	STYLE NO.	SYM.					
						GR.	1	2	3	4	5
/						/					

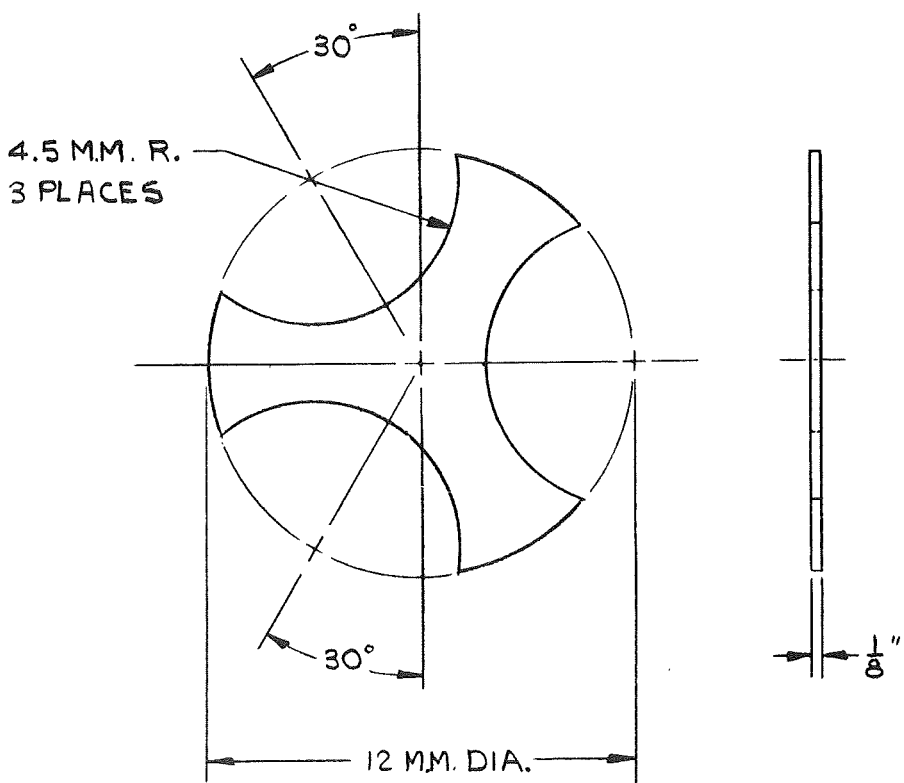

TOLERANCES		
UNLESS OTHERWISE SPECIFIED		
2 PL. DEC.	3 PL. DEC.	ANGLES
± .02	± .005	± 0.5°

861A032

S.O.	D.7636/4						
SUB.	1	HR	CSD				

WESTINGHOUSE ELECTRIC CORPORATION RESEARCH LABORATORIES CHURCHILL BORO, PITTSBURGH 35, PA., U.S.A.

TITLE ZERO GRAVITY CRYSTAL GROWING
PLATE DETAIL

DWG. A SUB. 1

FINISH CHART

SYM.	ITEM	DESCRIPTION - MATERIAL DIMENSIONS IN INCHES	PAT. NO. OR REF. DWG.	FIN. CH. LINE NO.	STYLE NO.	SYM.					R&D STR. NO.	
						GR.	1	2	3	4		5
	1	1.75 X 1.75 OF .062 SST SH #304					1					37 02

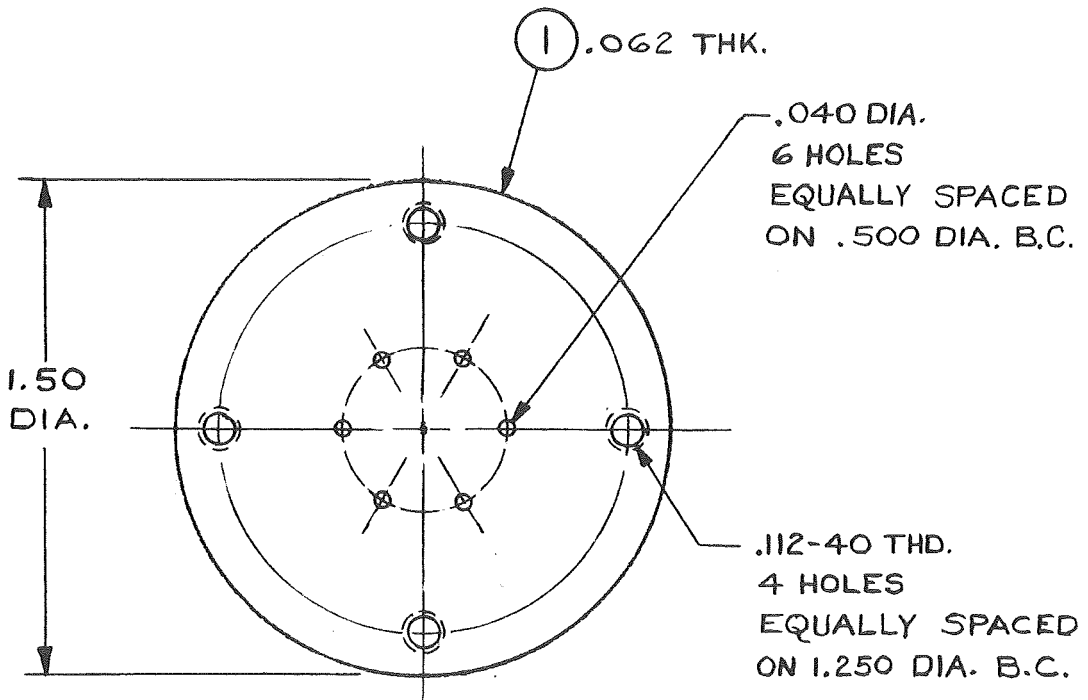

TOLERANCES		
UNLESS OTHERWISE SPECIFIED		
2 PL. DEC.	3 PL. DEC.	ANGLES
± .02	± .005	± 0.5°

861 A047

TITLE _____

DWG. B SUB. 1 FINISH CHART

SYM. ITEM	DESCRIPTION - MATERIAL DIMENSIONS IN INCHES	PAT. NO. OR REF. DWG.	FIN. CH. LINE NO.	STYLE NO.	SYM. GR.	FINISH CHART				
						1	2	3	4	5
* 1	22 MM O.D. X 20 MM I.D. QUARTZ TUBE					/				
* 2	FROM QUARTZ					/				

* FURN BY ENQ'R

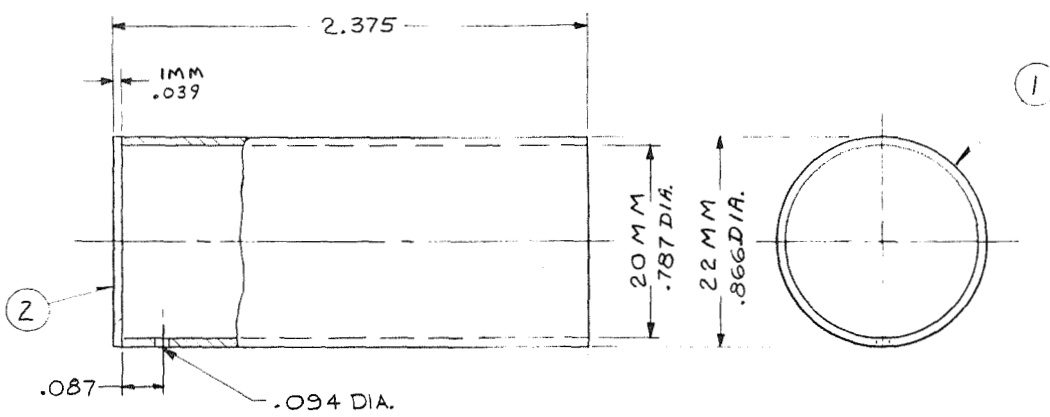

S.O. 1
D. 763614
IT. CHANGE

TOLERANCES		
UNLESS OTHERWISE SPECIFIED		
2 PL. DEC.	3 PL. DEC.	ANGLES
±.02	±.005	±0.5°

FINISH TO BE ✓ UNLESS OTHERWISE SPECIFIED

REV. 253 C 46

WESTINGHOUSE ELECTRIC CORPORATION

TITLE ZERO GRAVITY CRYSTAL GROWING
INSULATING CAP DETAIL

DIMENSIONS IN INCHES—DO NOT SCALE DRAWING SUB. 1

DFTM. CWL	8-4 1963	APPD. <u>LD</u>		
CHKD. HR	5-26 63	APPD.		
SUPV.		APPD.		

721 B 919

RESEARCH LABORATORIES CHURCHILL BORO, PITTSBURGH 35, PA., U.S.A.

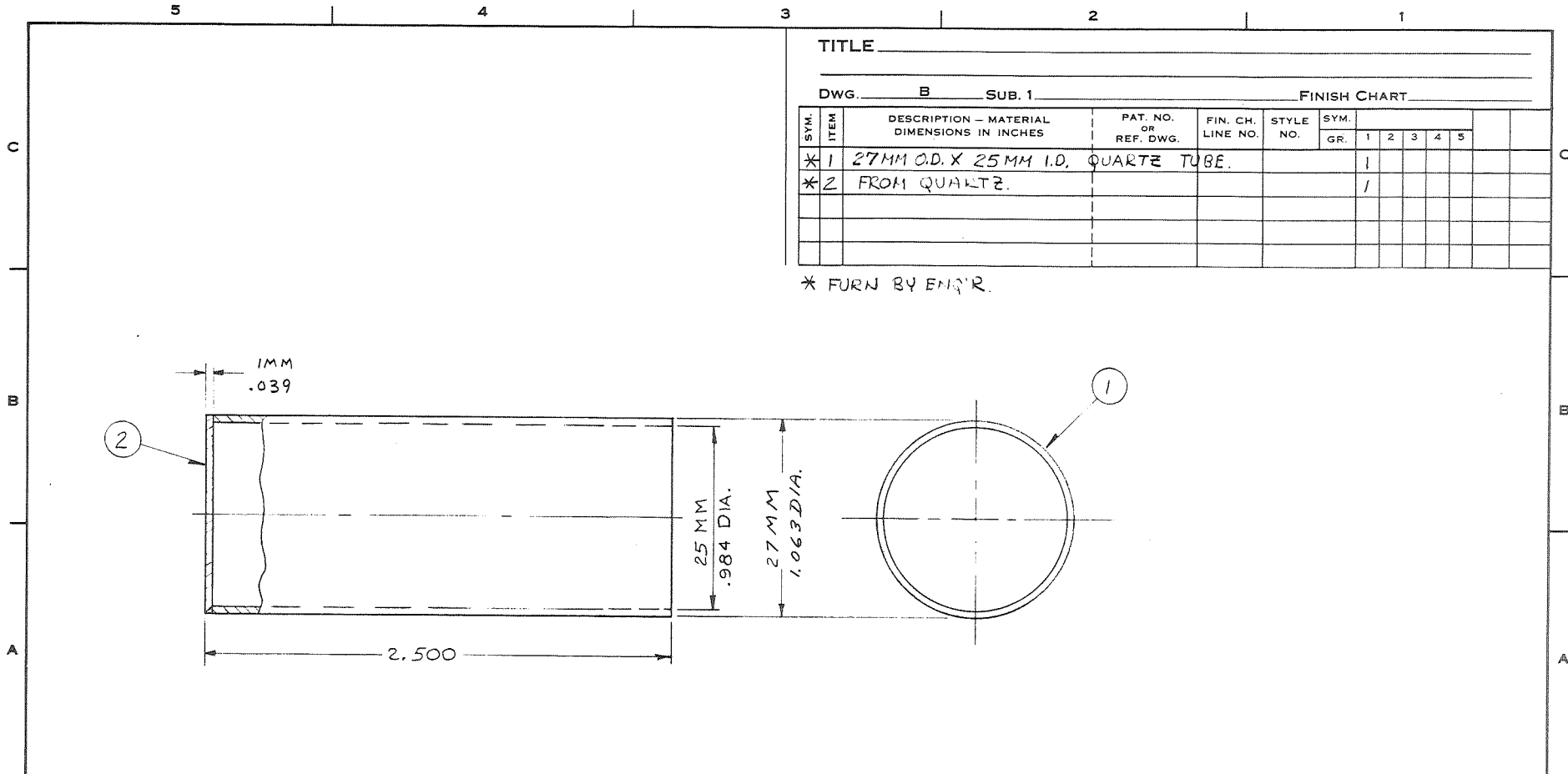

TITLE _____										
DWG. <u>B</u> SUB. 1 _____ FINISH CHART _____										
SYM. ITEM	DESCRIPTION - MATERIAL DIMENSIONS IN INCHES	PAT. NO. OR REF. DWG.	FIN. CH. LINE NO.	STYLE NO.	SYM. GR.					
						1	2	3	4	5
*1	27MM O.D. X 25MM I.D. QUARTZ TUBE.				1					
*2	FROM QUARTZ.				1					

* FURN BY ENGR.

S.O. 1
 D. 763614
 CHANGE
 IT.

TOLERANCES		
UNLESS OTHERWISE SPECIFIED		
2 PL. DEC.	3 PL. DEC.	ANGLES
±.02	±.005	±0.5°

FINISH TO BE ✓ UNLESS OTHERWISE SPECIFIED

REV. 253C466

WESTINGHOUSE ELECTRIC CORPORATION

TITLE ZERO GRAVITY CRYSTAL GROWING THERMAL CAP DETAIL

DIMENSIONS IN INCHES—DO NOT SCALE DRAWING				SUB. 1	
DFTM. <u>CWL</u>	<u>8-5</u> <u>1969</u>	APPD. <u>[Signature]</u>			
CHKD. <u>H.R.</u>	<u>8-26</u> <u>69</u>	APPD.			<u>721 B 920</u>
SUPV.		APPD.			

RESEARCH LABORATORIES CHURCHILL BORO. PITTSBURGH 35. PA., U.S.A.

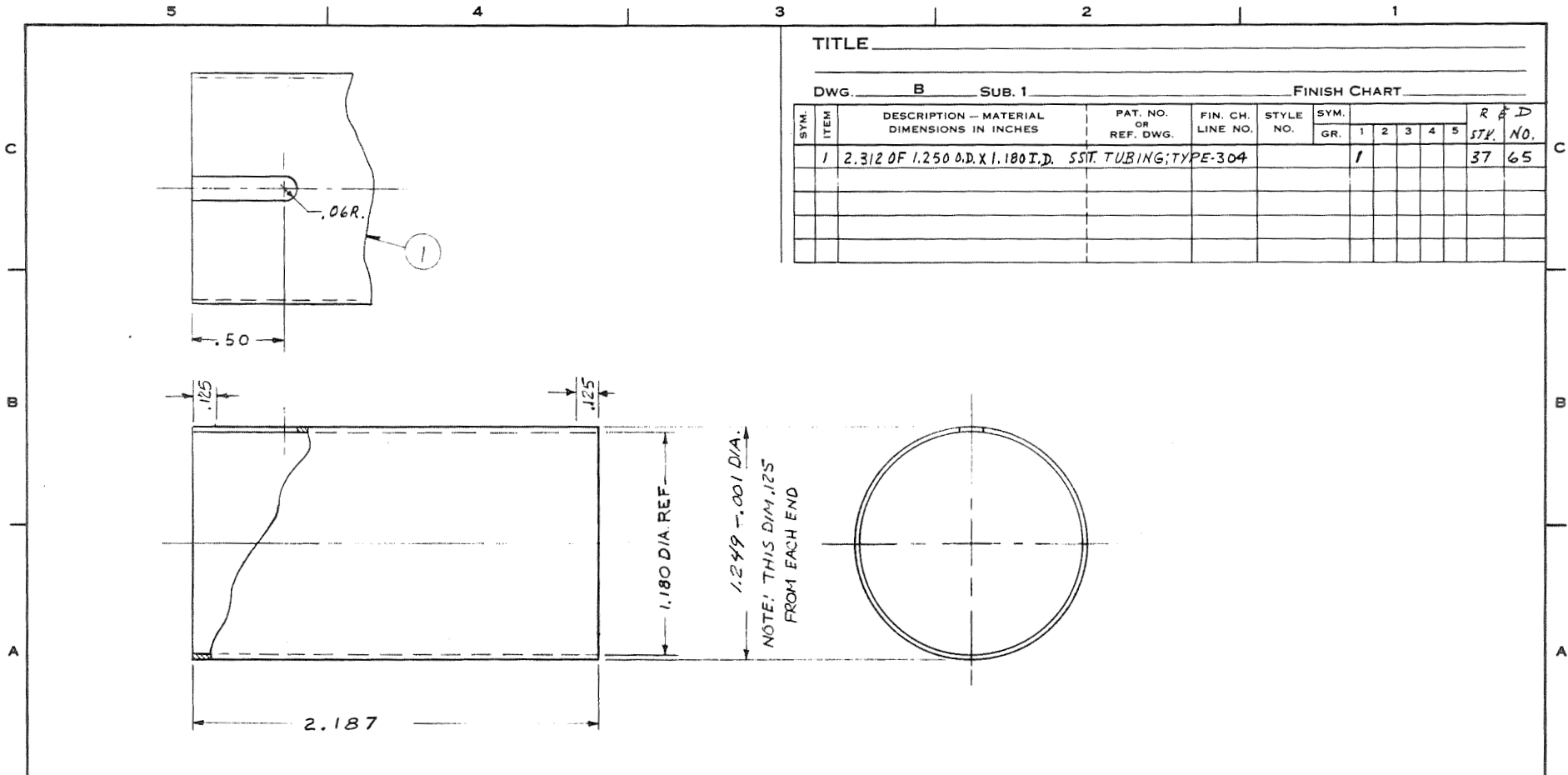

TITLE _____

DWG. B SUB. 1 FINISH CHART

SYM. ITEM	DESCRIPTION - MATERIAL DIMENSIONS IN INCHES	PAT. NO. OR REF. DWG.	FIN. CH. LINE NO.	STYLE NO.	SYM. GR.	FINISH CHART					R & D	
						1	2	3	4	5	SYM. NO.	DWG. NO.
1	2.312 OF 1.250 O.D. X 1.180 I.D. SST. TUBING; TYPE-304					1					37	65

TOLERANCES UNLESS OTHERWISE SPECIFIED		
2 PL. DEC.	3 PL. DEC.	ANGLES
±.02	±.005	±0.5°

FINISH TO BE ⁶³ UNLESS OTHERWISE SPECIFIED

WESTINGHOUSE ELECTRIC CORPORATION

TITLE ZERO GRAVITY CRYSTAL GROWING SPACER DETAIL

DIMENSIONS IN INCHES—DO NOT SCALE DRAWING SUB. 1

DFTM. <u>CWL</u>	<u>B-6</u> <u>1269</u>	APPD. <u>C.D.</u>
CHKD. <u>H.R.</u>	<u>B-26</u> <u>63</u>	APPD.
SUPV.		APPD.

721 B 921

RESEARCH LABORATORIES CHURCHILL BORO. PITTSBURGH 35, PA., U.S.A.

S.O. 1
D. 763614
IT. CHANGE

REF. DWG. 721 B 942

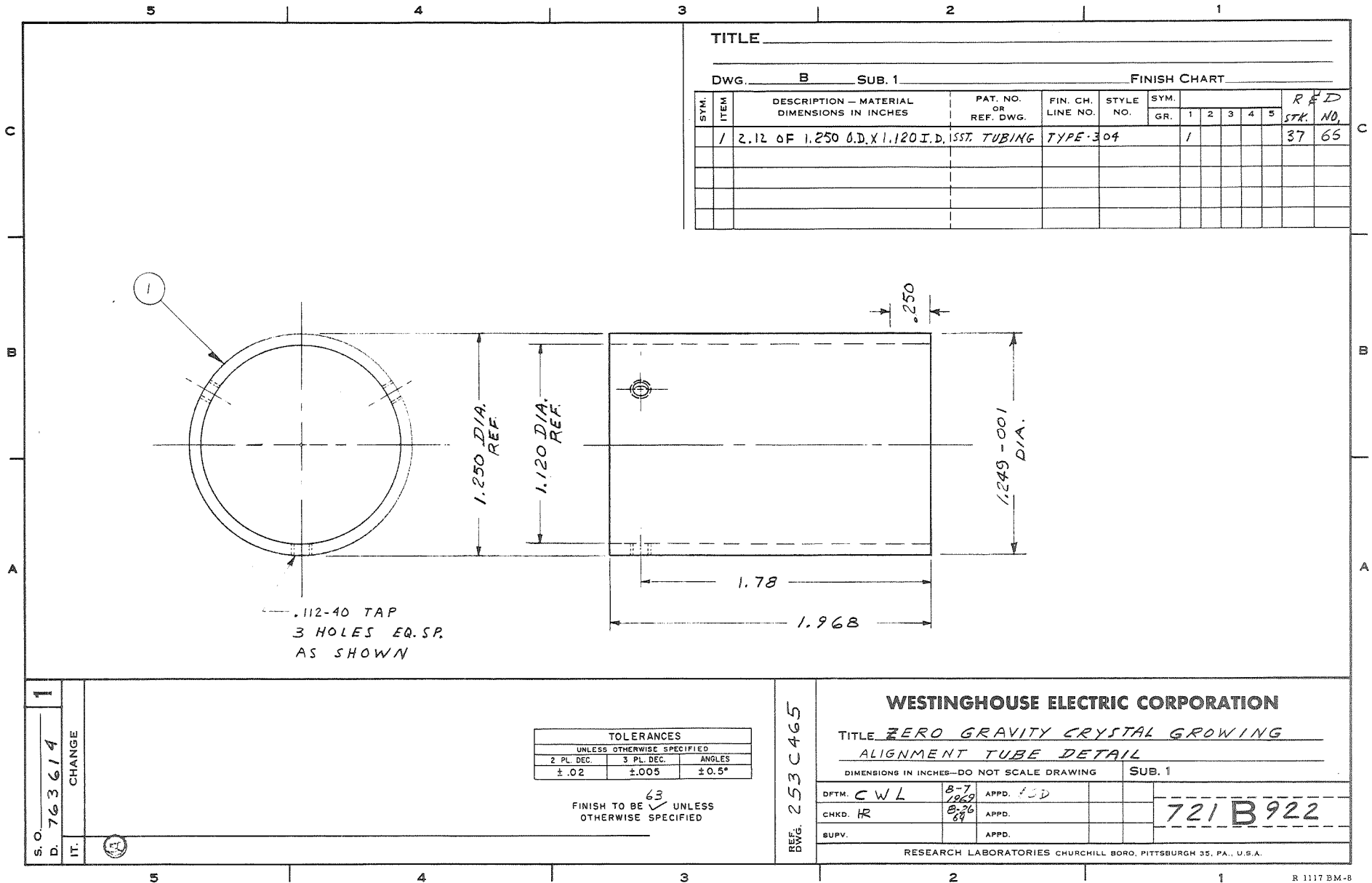

TITLE _____											
DWG. <u>B</u> SUB. 1 FINISH CHART											
SYM. ITEM	DESCRIPTION - MATERIAL DIMENSIONS IN INCHES	PAT. NO. OR REF. DWG.	FIN. CH. LINE NO.	STYLE NO.	SYM. GR.	R & D					
						1	2	3	4	5	
/	2.12 OF 1.250 O.D. X 1.120 I.D. SST. TUBING			TYPE-304		1					STK. NO. 37 65

S. O. 1
 D. 763614
 IT. CHANGE

TOLERANCES		
UNLESS OTHERWISE SPECIFIED		
2 PL. DEC.	3 PL. DEC.	ANGLES
± .02	± .005	± 0.5°

FINISH TO BE ⁶³ ✓ UNLESS OTHERWISE SPECIFIED

WESTINGHOUSE ELECTRIC CORPORATION

TITLE ZERO GRAVITY CRYSTAL GROWING
ALIGNMENT TUBE DETAIL

DIMENSIONS IN INCHES—DO NOT SCALE DRAWING SUB. 1

DFTM. <u>CWL</u>	<u>B-7</u> <u>1969</u>	APPD. <u>FSD</u>		
CHKD. <u>IR</u>	<u>B-36</u> <u>64</u>	APPD.		
SUPV.		APPD.		

721 B 922

RESEARCH LABORATORIES CHURCHILL BORO, PITTSBURGH 35, PA., U.S.A.

TITLE _____

DWG. B SUB. 1 FINISH CHART

SYM. ITEM	DESCRIPTION - MATERIAL DIMENSIONS IN INCHES	PAT. NO. OR REF. DWG.	FIN. CH. LINE NO.	STYLE NO.	SYM. GR.					STK. No.	REF. No.
					1	2	3	4	5		
1	2.12 OF 1.00 O.D. X .870 I.D. SST. TUBING TYPE -304				1					37	6!

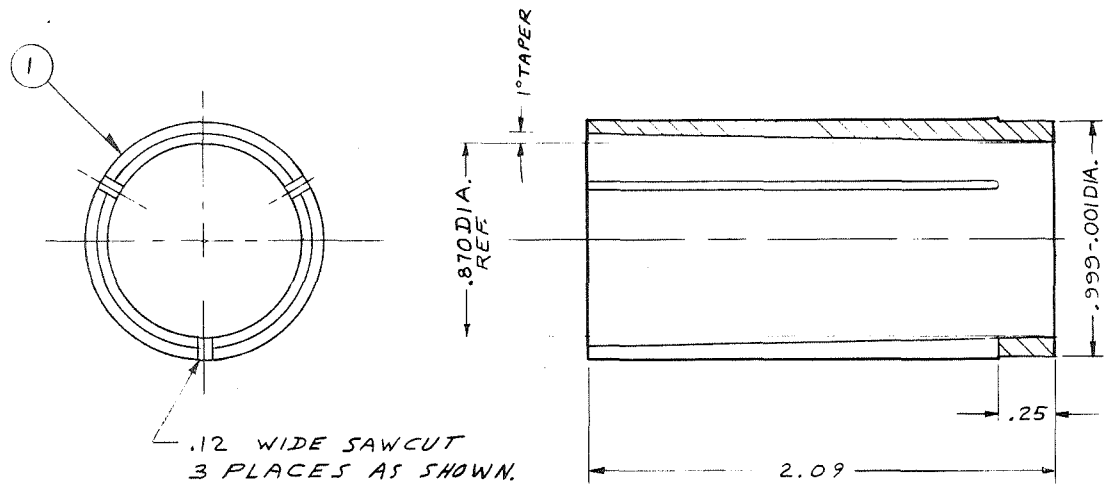

.12 WIDE SAWCUT
3 PLACES AS SHOWN.

S.O. 1
D. 763 614
IT. CHANGE

TOLERANCES		
UNLESS OTHERWISE SPECIFIED		
2 PL. DEC.	3 PL. DEC.	ANGLES
± .02	± .005	± 0.5°

FINISH TO BE 63 UNLESS OTHERWISE SPECIFIED

DWG. 253 C 465

WESTINGHOUSE ELECTRIC CORPORATION

TITLE ZERO GRAVITY CRYSTAL GROWING
SPLIT TUBE DETAIL

DIMENSIONS IN INCHES—DO NOT SCALE DRAWING SUB. 1

DFTM. <u>CWL</u>	<u>8-7 1965</u>	APPD. <u>60D</u>		
CHKD. <u>HR</u>	<u>8-26 69</u>	APPD.		
SUPV.		APPD.		

721 B 926

RESEARCH LABORATORIES CHURCHILL BORO, PITTSBURGH 35, PA., U.S.A.

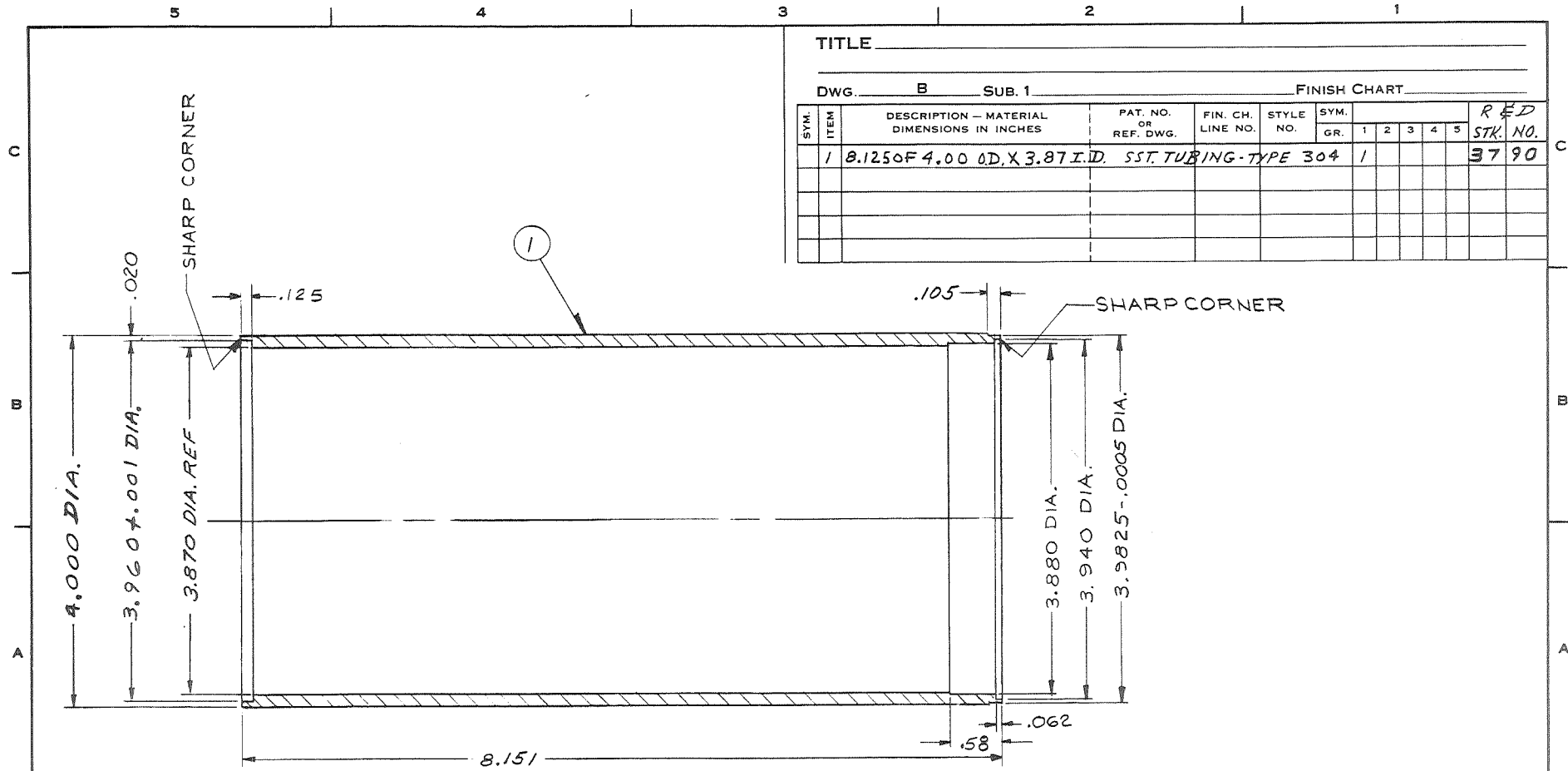

TITLE _____										
DWG. <u>B</u> SUB. 1					FINISH CHART _____					
SYM. ITEM	DESCRIPTION - MATERIAL DIMENSIONS IN INCHES	PAT. NO. OR REF. DWG.	FIN. CH. LINE NO.	STYLE NO.	SYM. GR.	RED STRK. NO.				
						1	2	3	4	5
1	8.1250F 4.00 OD, X 3.87 I.D.	SST. TUBING - TYPE 304			1					3790

S. O.	1
D.	763614
IT.	CHANGE

TOLERANCES		
UNLESS OTHERWISE SPECIFIED		
2 PL. DEC.	3 PL. DEC.	ANGLES
± .02	± .005	± 0.5°

FINISH TO BE $\sqrt{3}$ UNLESS OTHERWISE SPECIFIED

REV. 253C464

WESTINGHOUSE ELECTRIC CORPORATION

TITLE ZERO GRAVITY CRYSTAL GROWING HOUSING DETAIL

DIMENSIONS IN INCHES—DO NOT SCALE DRAWING

SUB. 1	
DFTM. C.W.L.	8-7 1960 APPD. OSD
CHKD. HR	8-26 63 APPD.
SUPV.	APPD.

721 B 928

RESEARCH LABORATORIES CHURCHILL BORO, PITTSBURGH 35, PA., U.S.A.

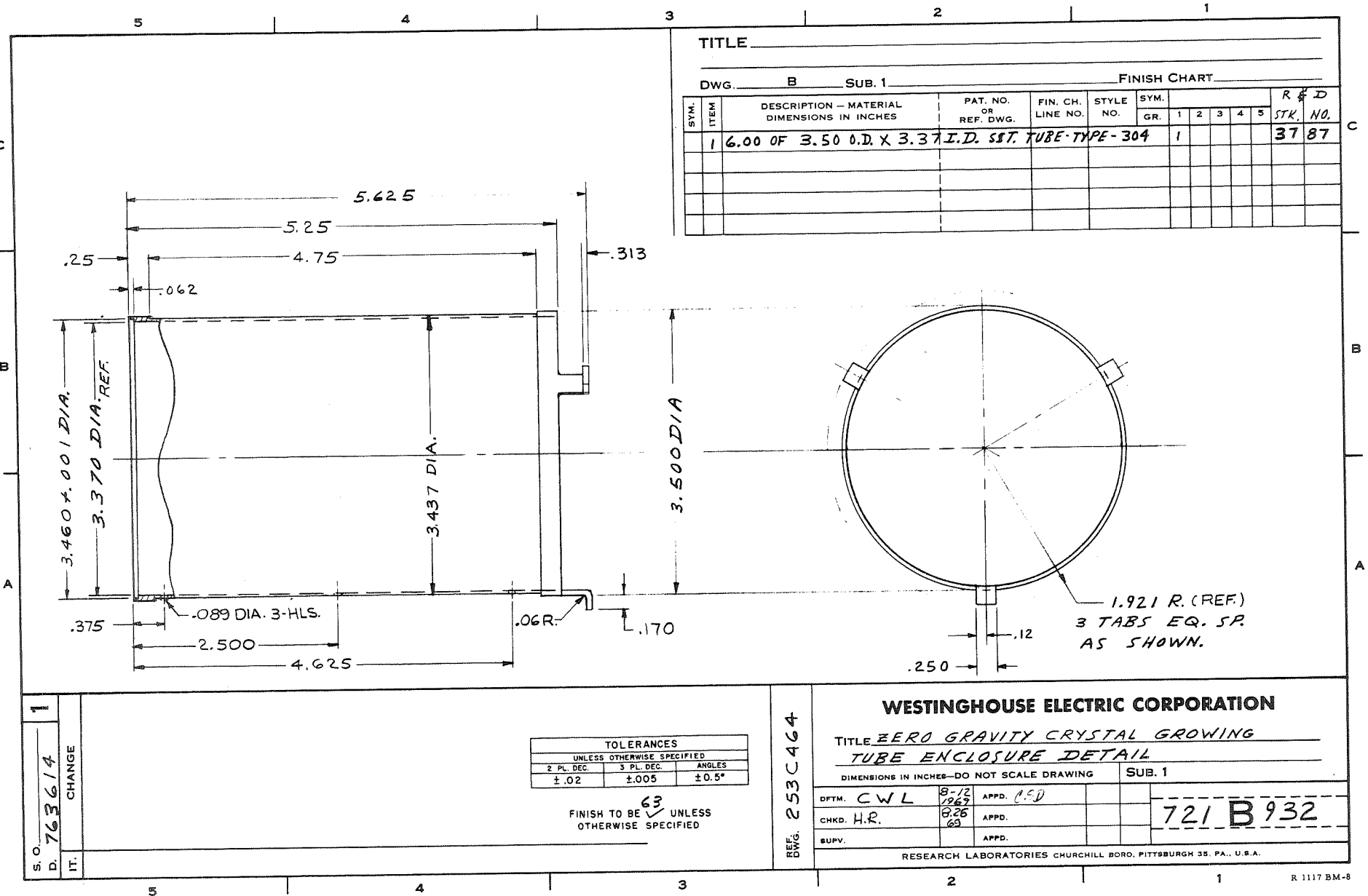

TITLE _____											
DWG. B SUB. 1					FINISH CHART						
SYM. ITEM	DESCRIPTION - MATERIAL DIMENSIONS IN INCHES	PAT. NO. OR REF. DWG.	FIN. CH. LINE NO.	STYLE NO.	SYM. GR.	R & D					
						1	2	3	4	5	
1	6.00 OF 3.50 O.D. X 3.37 I.D. SST. TUBE TYPE-304				1						3787

S.O. 1
D. 763614
IT. CHANGE

TOLERANCES		
UNLESS OTHERWISE SPECIFIED		
2 PL. DEC.	3 PL. DEC.	ANGLES
±.02	±.005	±0.5°

FINISH TO BE $\sqrt{63}$ UNLESS OTHERWISE SPECIFIED

REF. DWG. 253C464

WESTINGHOUSE ELECTRIC CORPORATION

TITLE ZERO GRAVITY CRYSTAL GROWING
TUBE ENCLOSURE DETAIL

DIMENSIONS IN INCHES—DO NOT SCALE DRAWING SUB. 1

DFTM. CWL	8-12 1967	APPD. C.S.D.			
CHKD. H.R.	8-26 69	APPD.			721 B 932
SUPV.		APPD.			

RESEARCH LABORATORIES CHURCHILL BORO, PITTSBURGH 35, PA., U.S.A.

5 4 3 2 1

TITLE _____

DWG. B SUB. 1 FINISH CHART

SYM. ITEM	DESCRIPTION - MATERIAL DIMENSIONS IN INCHES	PAT. NO. OR REF. DWG.	FIN. CH. LINE NO.	STYLE NO.	SYM.					R # D STK. NO.	
					GR.	1	2	3	4		5
1	3.468 DIA. OF .062 THK. SST. PL. TYPE 304					1					37 02

C
B
A

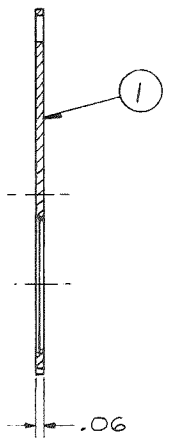
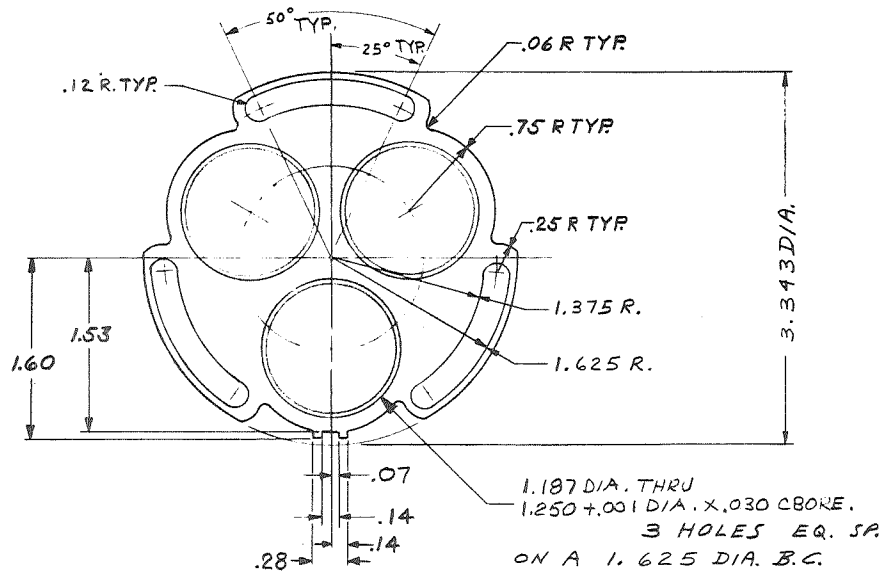

C
B
A

S. O. D. 763614
IT. CHANGE

TOLERANCES		
UNLESS OTHERWISE SPECIFIED		
2 PL. DEC.	3 PL. DEC.	ANGLES
± .02	± .005	± 0.5°

FINISH TO BE \checkmark 63 UNLESS OTHERWISE SPECIFIED

REF. DWG. 721 B 942

WESTINGHOUSE ELECTRIC CORPORATION

TITLE ZERO GRAVITY CRYSTAL GROWING
FRONT TUBE SUPPORT DETAIL

DIMENSIONS IN INCHES—DO NOT SCALE DRAWING SUB. 1

DFTM. CWL	8-9 1969	APPD. <i>C.S.D.</i>					
CHKD. H.R.	9-26 69	APPD.					
SUPV.		APPD.					

721 B 940

RESEARCH LABORATORIES CHURCHILL BORO, PITTSBURGH 35, PA., U.S.A.

5 4 3 2 1

TITLE _____

DWG. B SUB. 1 FINISH CHART

SYM. ITEM	DESCRIPTION - MATERIAL DIMENSIONS IN INCHES	PAT. NO. OR REF. DWG.	FIN. CH. LINE NO.	STYLE NO.	SYM. GR.	R & D					
						1	2	3	4	5	STK. NO.
1	3.50 DIA. OF .062 THK. SST. PL. TYPE 304					1					37 02

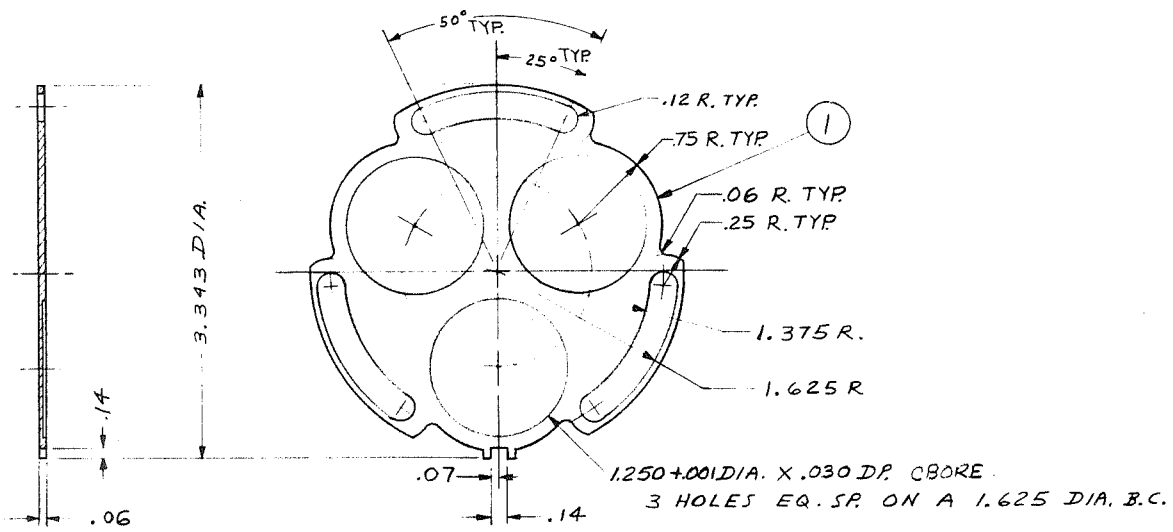

S.O. 1
D. 763614
IT. CHANGE

TOLERANCES		
UNLESS OTHERWISE SPECIFIED		
2 PL. DEC.	3 PL. DEC.	ANGLES
± .02	± .005	± 0.5°

FINISH TO BE 63 UNLESS OTHERWISE SPECIFIED

REF. DWG. 721B942

WESTINGHOUSE ELECTRIC CORPORATION

TITLE ZERO GRAVITY CRYSTAL GROWING REAR TUBE SUPPORT DETAIL

DIMENSIONS IN INCHES—DO NOT SCALE DRAWING SUB. 1

DFTM. <u>CWL</u>	<u>8-9 1965</u>	APPD. <u>BSD</u>		
CHKD. <u>H.R.</u>	<u>9-26 68</u>	APPD.		<u>721 B 941</u>
SUPV.		APPD.		

RESEARCH LABORATORIES CHURCHILL BORO, PITTSBURGH 35, PA., U.S.A.

TITLE _____

DWG. B SUB. 1 FINISH CHART

SYM. ITEM	DESCRIPTION - MATERIAL DIMENSIONS IN INCHES	PAT. NO. OR REF. DWG.	FIN. CH. LINE NO.	STYLE NO.	SYM. GR.					
						1	2	3	4	5
1	17.1 - 721B941				1					
2	17.1 - 721B940				1					
3	17.1 - 721B921				3					

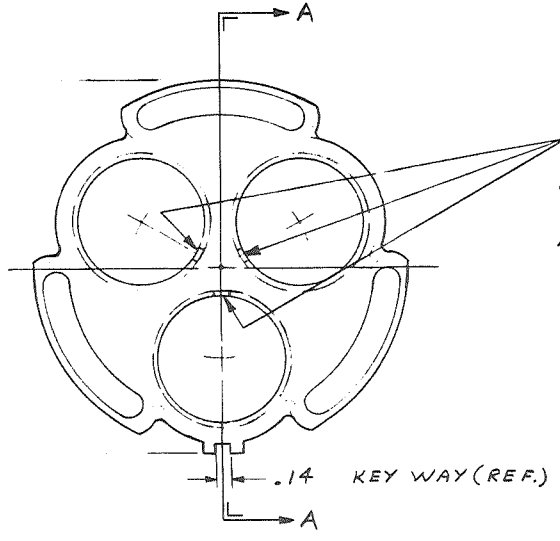
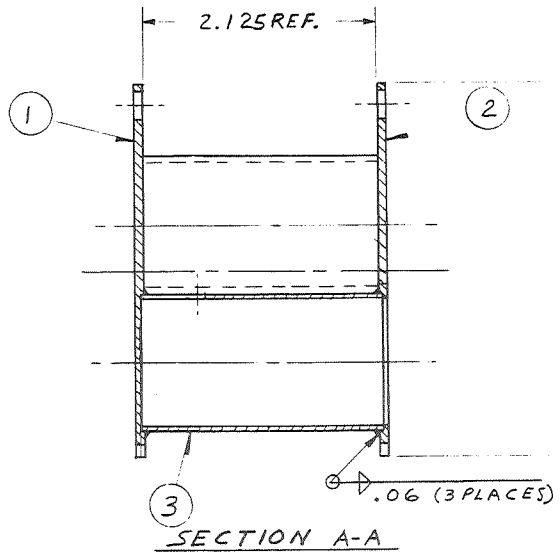

S.O. 1
D. 763614
IT. CHANGE

TOLERANCES		
UNLESS OTHERWISE SPECIFIED		
2 PL. DEC.	3 PL. DEC.	ANGLES
±.02	±.005	±0.5°

FINISH TO BE ✓ UNLESS OTHERWISE SPECIFIED

REV. 253 C466

WESTINGHOUSE ELECTRIC CORPORATION

TITLE ZERO GRAVITY CRYSTAL GROWING TUBE SUPPORT SUB-ASSY.

DIMENSIONS IN INCHES—DO NOT SCALE DRAWING SUB. 1

DFTM. <u>CWL</u>	<u>8-9</u> <u>1969</u>	APPD. <u>CSD</u>				
CHKD. <u>H.R.</u>	<u>9-26</u> <u>1969</u>	APPD.				
BUPV.		APPD.				

721 B 942

RESEARCH LABORATORIES CHURCHILL BORO. PITTSBURGH 35, PA., U.S.A.

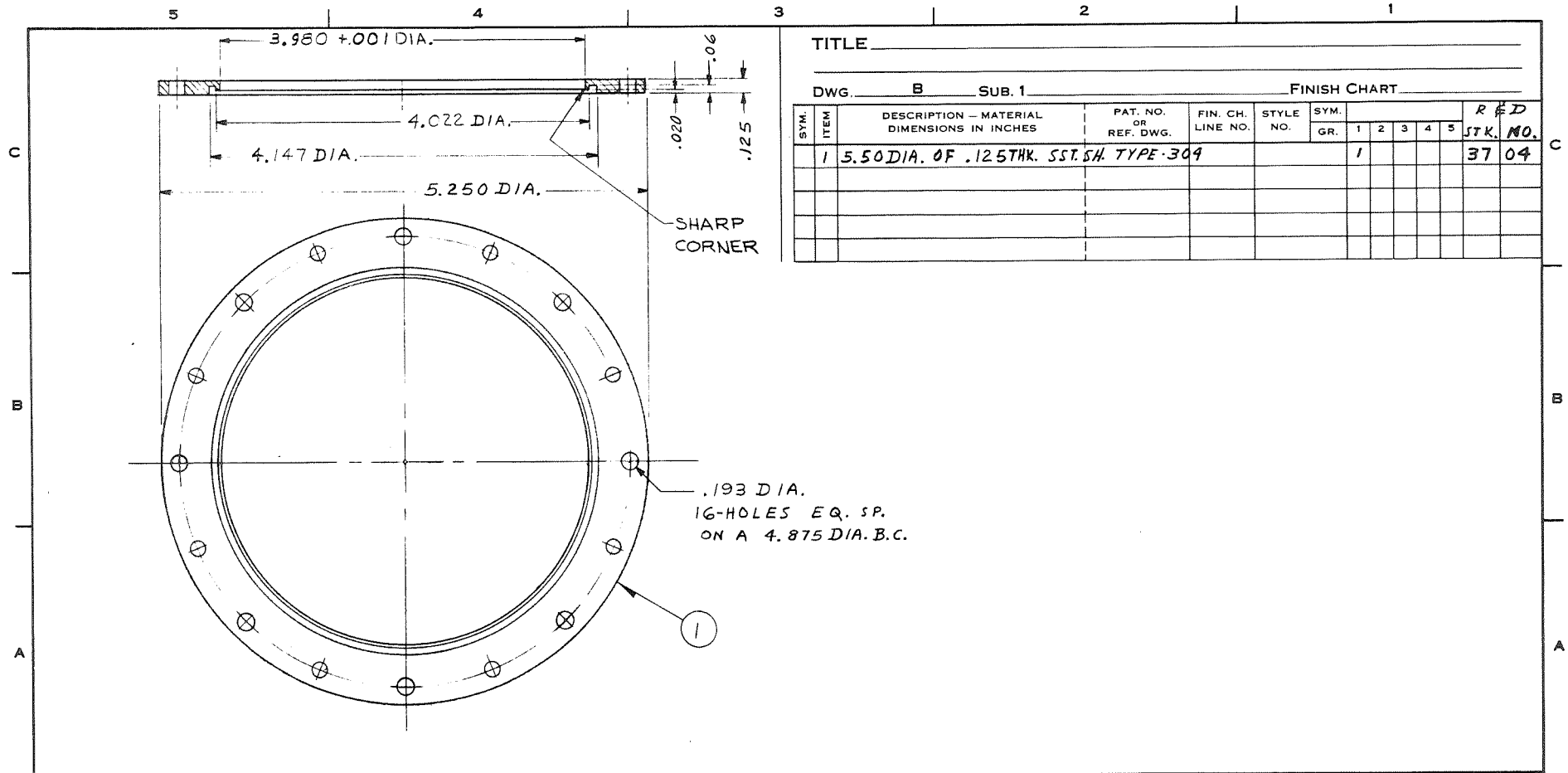

TITLE _____										
DWG. B SUB. 1					FINISH CHART					
SYM. ITEM	DESCRIPTION - MATERIAL DIMENSIONS IN INCHES	PAT. NO. OR REF. DWG.	FIN. CH. LINE NO.	STYLE NO.	SYM. GR.					R & D STK. NO.
					1	2	3	4	5	
1	5.50 DIA. OF .125 THK. SST. SH. TYPE 304				1					37 04

.193 DIA.
16-HOLES EQ. SP.
ON A 4.875 DIA. B.C.

SHARP CORNER

S.O. **1**
D. **763614**
IT. CHANGE

TOLERANCES		
UNLESS OTHERWISE SPECIFIED		
2 PL. DEC.	3 PL. DEC.	ANGLES
±.02	±.005	±0.5°

FINISH TO BE **62** UNLESS OTHERWISE SPECIFIED

REF. DWG. **253C464**

WESTINGHOUSE ELECTRIC CORPORATION

TITLE *ZERO GRAVITY CRYSTAL GROWING*
FLANGE DETAIL

DIMENSIONS IN INCHES—DO NOT SCALE DRAWING SUB. 1

DFTM. <i>C. W. L</i>	<i>8-19</i>	APPD. <i>WSD</i>	
CHKD. <i>H.R.</i>	<i>8-23</i>	APPD.	
SUPV.		APPD.	

721 B 948

RESEARCH LABORATORIES CHURCHILL BORO, PITTSBURGH 35, PA., U.S.A.

5 4 3 2 1

TITLE _____

DWG. B SUB. 1 FINISH CHART

SYM. ITEM	DESCRIPTION - MATERIAL DIMENSIONS IN INCHES	PAT. NO. OR REF. DWG.	FIN. CH. LINE NO.	STYLE NO.	SYM.					R. # D.		
					GR.	1	2	3	4	5	STK. NO.	No.
1	.437 OF 4.00 DIA. SST. ROD - TYPE - 304										35	48

.112-40 TAP X .25 DP
3-HLS. EQ. SP. ON
A 3.062 B.C.

.140 DIA.
8-HOLES EQ. SPACED
ON A 3.610 B.C.

.086-56 TAP X .125 DP
4-HOLES EQ. SPACED ON
A 1.125 B.C. - 3 PLACES.

15°
1.612 R
.687 R.
.16 R.
TYP.

.875 DIA. ±
1.000 +.001 C'BORE X .25 DP,
1.250 +.001 C'BORE X .12 DP.
3-HLS. EQ. SP. ON A 1.625 B.C.

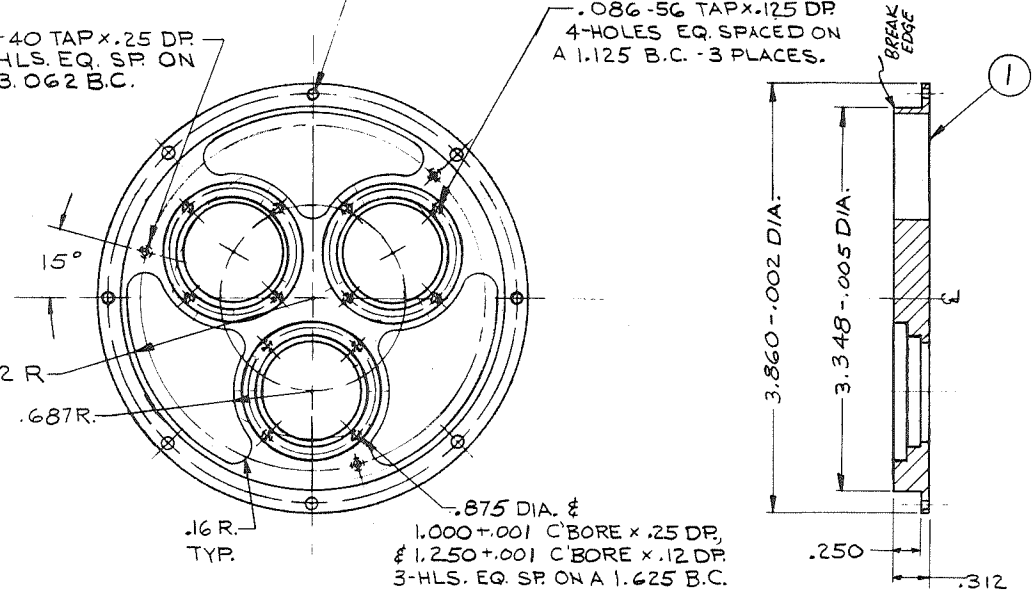

S. O. 1
D. 763614
IT. CHANGE

TOLERANCES		
UNLESS OTHERWISE SPECIFIED		
2 PL. DEC.	3 PL. DEC.	ANGLES
± .02	± .005	± 0.5°

FINISH TO BE ✓ UNLESS OTHERWISE SPECIFIED

REV. 253 C 466

WESTINGHOUSE ELECTRIC CORPORATION
TITLE ZERO GRAVITY CRYSTAL GROWING
ALIGNMENT PLATE DETAIL
DIMENSIONS IN INCHES—DO NOT SCALE DRAWING SUB. 1

DFTM. <u>C. W. L</u>	8-15 1969	APPD. <u>JOD</u>		
CHKD. <u>HR</u>	8-26 69	APPD.		
SUPV.		APPD.		

721 B952

RESEARCH LABORATORIES CHURCHILL BORO, PITTSBURGH 35, PA., U.S.A.

5 4 3 2 1

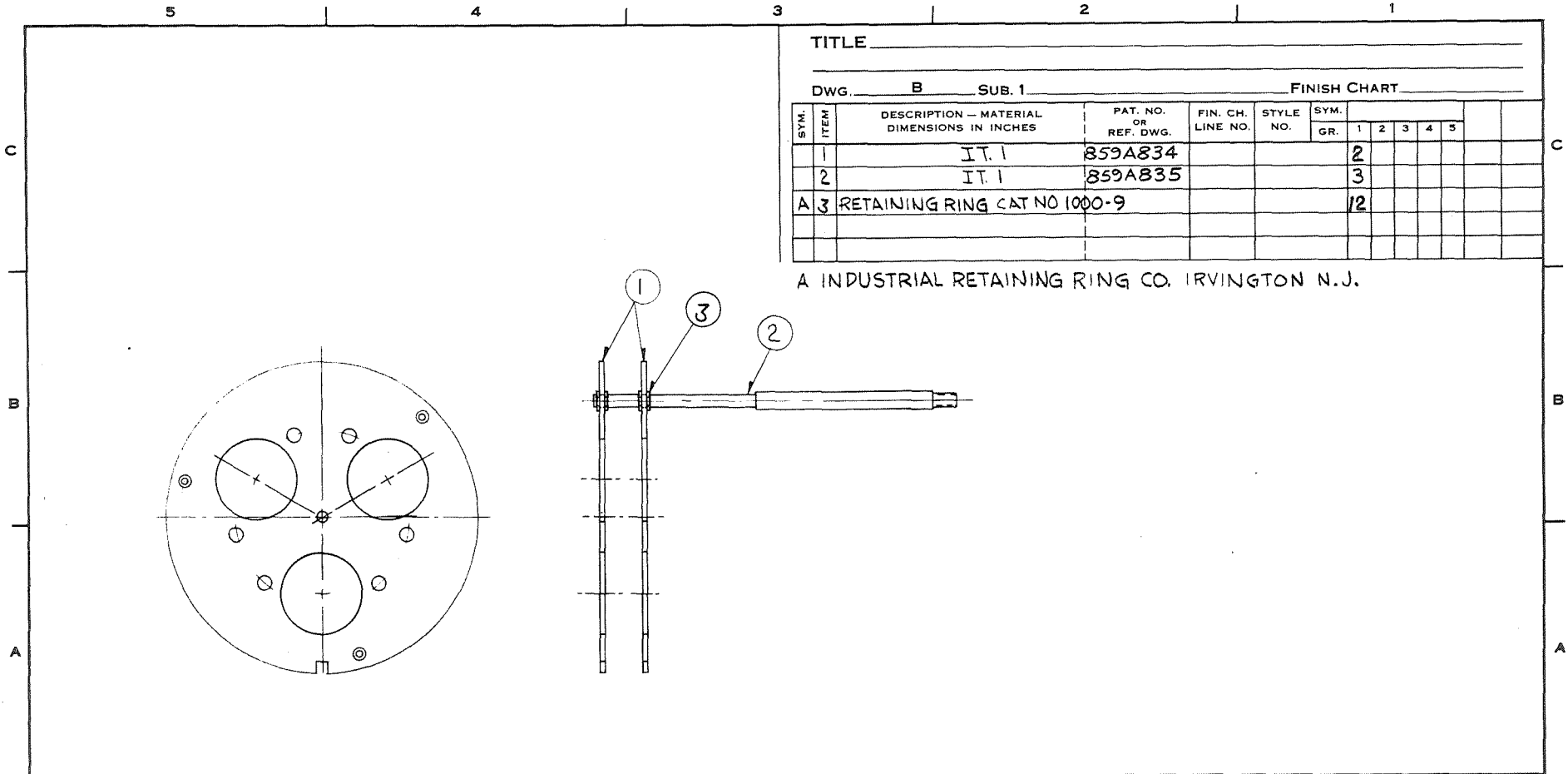

TITLE _____										
DWG. <u>B</u> SUB. <u>1</u> FINISH CHART										
SYM. ITEM	DESCRIPTION - MATERIAL DIMENSIONS IN INCHES	PAT. NO. OR REF. DWG.	FIN. CH. LINE NO.	STYLE NO.	SYM. GR.	FINISH CHART				
						1	2	3	4	5
1	IT. 1	859A834			2					
2	IT. 1	859A835			3					
A 3	RETAINING RING CAT NO 1000-9				12					

A INDUSTRIAL RETAINING RING CO. IRVINGTON N.J.

S.O. 1
D. 763614
IT. CHANGE

TOLERANCES		
UNLESS OTHERWISE SPECIFIED		
2 PL. DEC.	3 PL. DEC.	ANGLES
±.02	±.005	±0.5°

FINISH TO BE ✓ UNLESS OTHERWISE SPECIFIED

REF. 253C466

WESTINGHOUSE ELECTRIC CORPORATION

TITLE ZERO GRAVITY CRYSTAL GROWING
HEAT SHIELD SUB-ASS'Y.

DIMENSIONS IN INCHES—DO NOT SCALE DRAWING SUB. 1

DFTM. W.C.S.	8-16	APPD. <i>SD</i>		
CHKD. HR	8-26	APPD.		
BUPV.	69	APPD.		

721 B960

RESEARCH LABORATORIES CHURCHILL BORO, PITTSBURGH 35, PA., U.S.A.

5 4 3 2 1

TITLE _____

DWG. B SUB. 1 FINISH CHART

SYM. ITEM	DESCRIPTION - MATERIAL DIMENSIONS IN INCHES	PAT. NO. OR REF. DWG.	FIN. CH. LINE NO.	STYLE NO.	SYM.					
					GR.	1	2	3	4	5
* 1	4.12 OF 4.50 OD. X 3.38 ID. ST. TUBING SEAMLESS				1					

* RYERSON STEEL, CARNEGIE, PA.

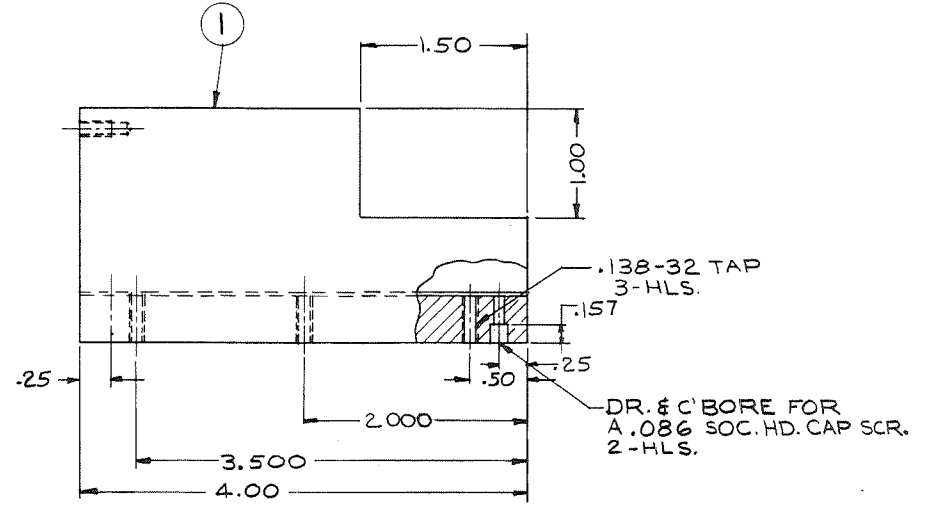
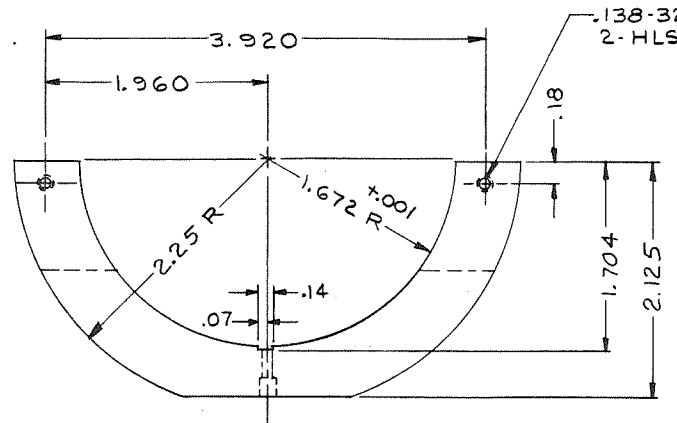

1
S. 9763614
D. 763614
CHANGE
IT.

TOLERANCES		
UNLESS OTHERWISE SPECIFIED		
2 PL. DEC.	3 PL. DEC.	ANGLES
± .02	± .005	± 0.5°

FINISH TO BE ✓ UNLESS OTHERWISE SPECIFIED

REF. 253C505

WESTINGHOUSE ELECTRIC CORPORATION

TITLE ZERO GRAVITY CRYSTAL GROWING
ALIGNMENT TUBE DETAIL

DIMENSIONS IN INCHES—DO NOT SCALE DRAWING SUB. 1

DFTM. W.C.S.	9-4-65	APPD. <i>ESD</i>	
CHKD. <i>HR</i>		APPD.	
SUPV.		APPD.	

722 B 004

RESEARCH LABORATORIES CHURCHILL BORO, PITTSBURGH 35, PA., U.S.A.

5 4 3 2 1

TITLE _____										
DWG. B SUB. 1 FINISH CHART										
SYM. ITEM	DESCRIPTION - MATERIAL DIMENSIONS IN INCHES	PAT. NO. OR REF. DWG.	FIN. CH. LINE NO.	STYLE NO.	SYM. GR.					RE D STK. NO.
					1	2	3	4	5	
1	4.62 x 4.50 OF .25 THK. TOOL ST.			OIL HARD.						40 16

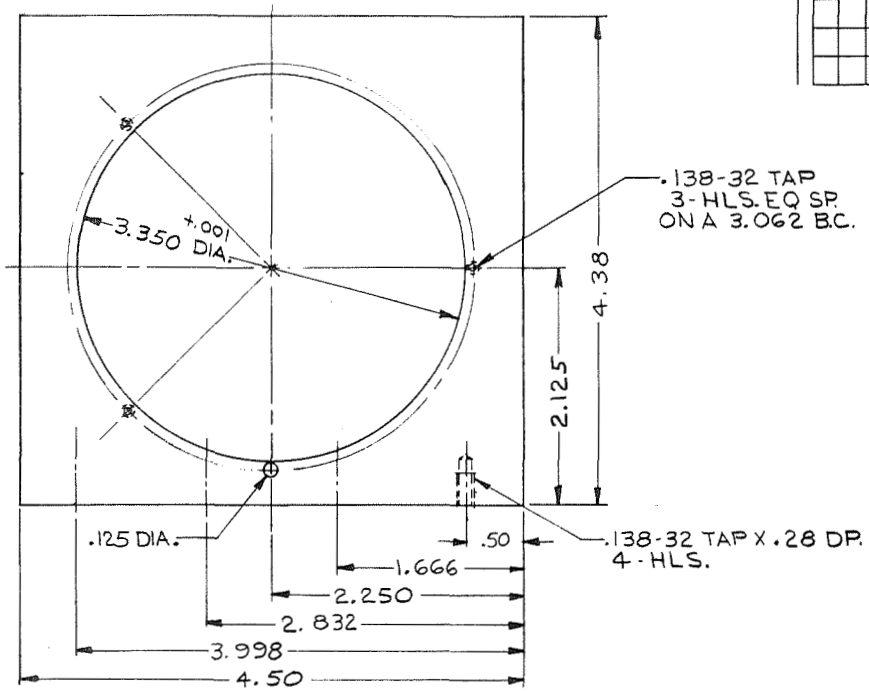

1
S. O. CHANGE
D. 763614
IT.

TOLERANCES		
UNLESS OTHERWISE SPECIFIED		
2 PL. DEC.	3 PL. DEC.	ANGLES
±.02	±.005	±0.5°

FINISH TO BE ✓ UNLESS OTHERWISE SPECIFIED

WESTINGHOUSE ELECTRIC CORPORATION
 TITLE ZERO GRAVITY CRYSTAL GROWING
ALIGNMENT PLATE DETAIL
 DIMENSIONS IN INCHES—DO NOT SCALE DRAWING SUB. 1

DFTM. W.C.S.	9468	APPD. CSD		
CHKD. HR		APPD.		
SUPV.		APPD.		

722 B 005

RESEARCH LABORATORIES CHURCHILL BORO, PITTSBURGH 35, PA., U.S.A.

REV. 253 C 505

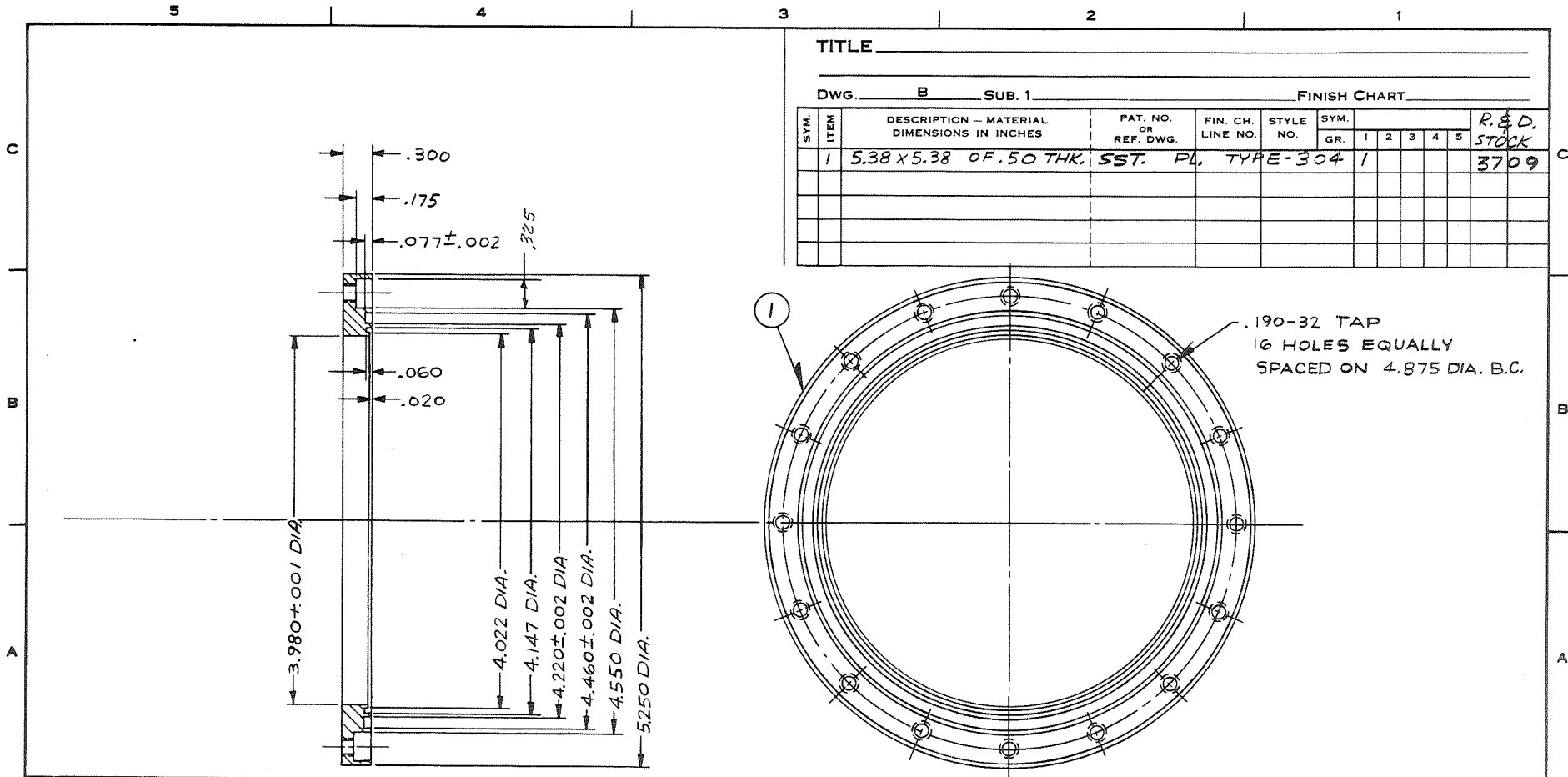

TITLE _____										
DWG. <u>B</u> SUB. 1					FINISH CHART					
SYM. ITEM	DESCRIPTION - MATERIAL DIMENSIONS IN INCHES	PAT. NO. OR REF. DWG.	FIN. CH. LINE NO.	STYLE NO.	SYM.					R. & D. STOCK 3709
					GR.	1	2	3	4	
1	5.38 x 5.38 OF .50 THK. SST. PL. TYPE-304				1					

S. O. 1
D. 763614
IT. _____

CHANGE

TOLERANCES UNLESS OTHERWISE SPECIFIED		
2 PL. DEC.	3 PL. DEC.	ANGLES
± .02	± .005	± 0.5°

FINISH TO BE UNLESS OTHERWISE SPECIFIED

WESTINGHOUSE ELECTRIC CORPORATION

TITLE ZERO GRAVITY CRYSTAL GROWING

DETAIL

DIMENSIONS IN INCHES—DO NOT SCALE DRAWING SUB. 1

DFTM. <u>K. SCHRIMM</u>	APPD. <u>[Signature]</u>	722 B 061
CHKD. <u>[Signature]</u>	APPD.	
SUPV.	APPD.	

RESEARCH LABORATORIES CHURCHILL BORO, PITTSBURGH 35, PA., U.S.A.

REF. DWG.

TITLE _____

DWG. B SUB. 1 FINISH CHART

SYM. ITEM	DESCRIPTION - MATERIAL DIMENSIONS IN INCHES	PAT. NO. OR REF. DWG.	FIN. CH. LINE NO.	STYLE NO.	SYM. GR.	FINISH CHART				
						1	2	3	4	5
1	QUARTZ TUBE GR. 1	253C438				/				
2	DISC IT. 1	860A032				/				
3	PLUG & FINGERS IT. 1	860A250				/				
4	SEED					/				

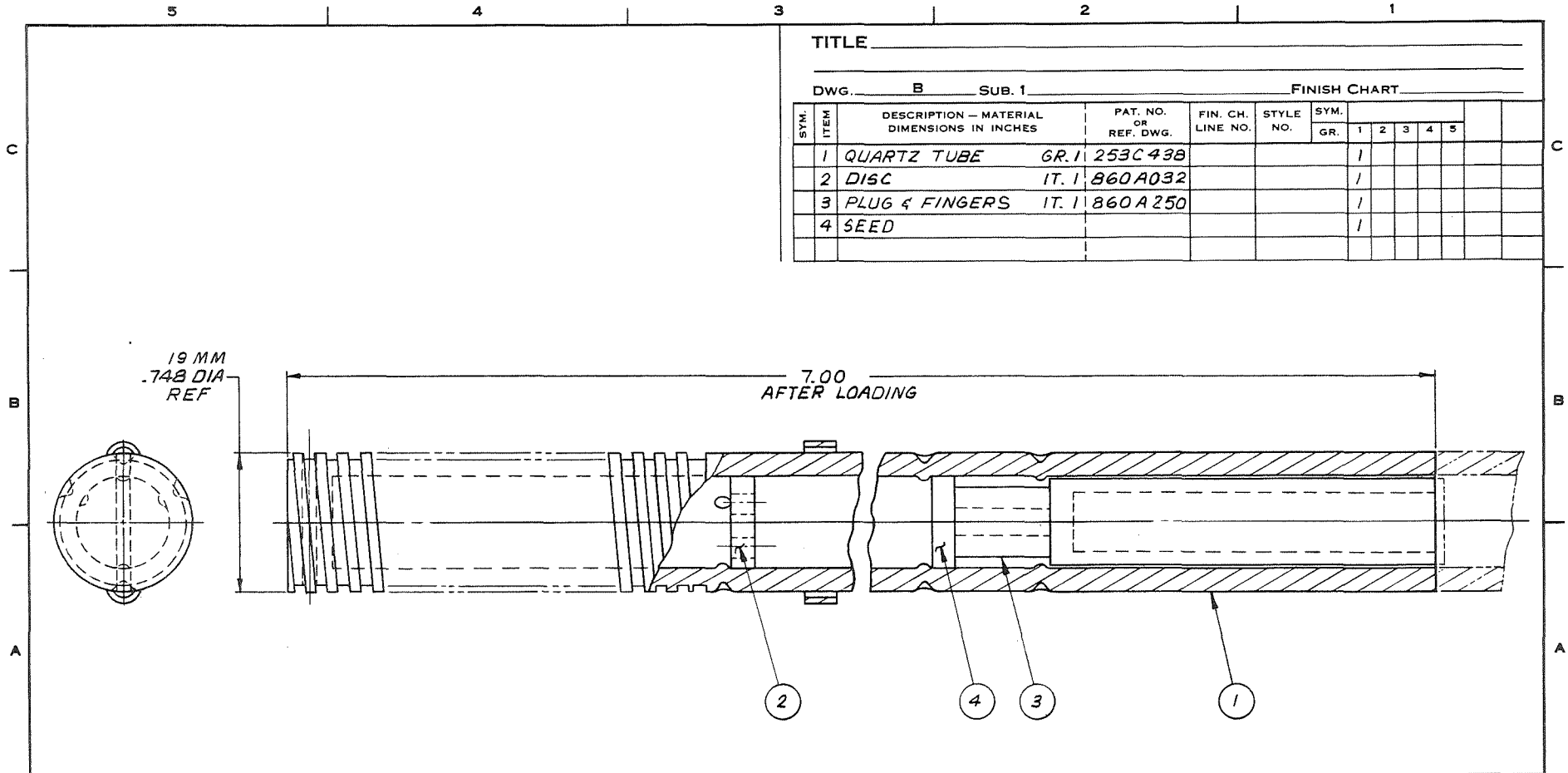

1
S. O. CHANGE
D. 763614
IT.

TOLERANCES UNLESS OTHERWISE SPECIFIED		
2 PL. DEC.	3 PL. DEC.	ANGLES
±.02	±.005	±0.5°

FINISH TO BE ¹²⁵ UNLESS OTHERWISE SPECIFIED

DWG. 253 C 466

WESTINGHOUSE ELECTRIC CORPORATION

TITLE ZERO GRAVITY CRYSTAL GROWING TUBE ASSEMBLY

DIMENSIONS IN INCHES—DO NOT SCALE DRAWING SUB. 1

DFTM. H. DUMAS	1-12-70	APPD. <i>SD</i>	
CHKD. EZEGLER	1-13-70	APPD.	
SUPV.		APPD.	

722 B216

RESEARCH LABORATORIES CHURCHILL BORO. PITTSBURGH 35, PA., U.S.A.

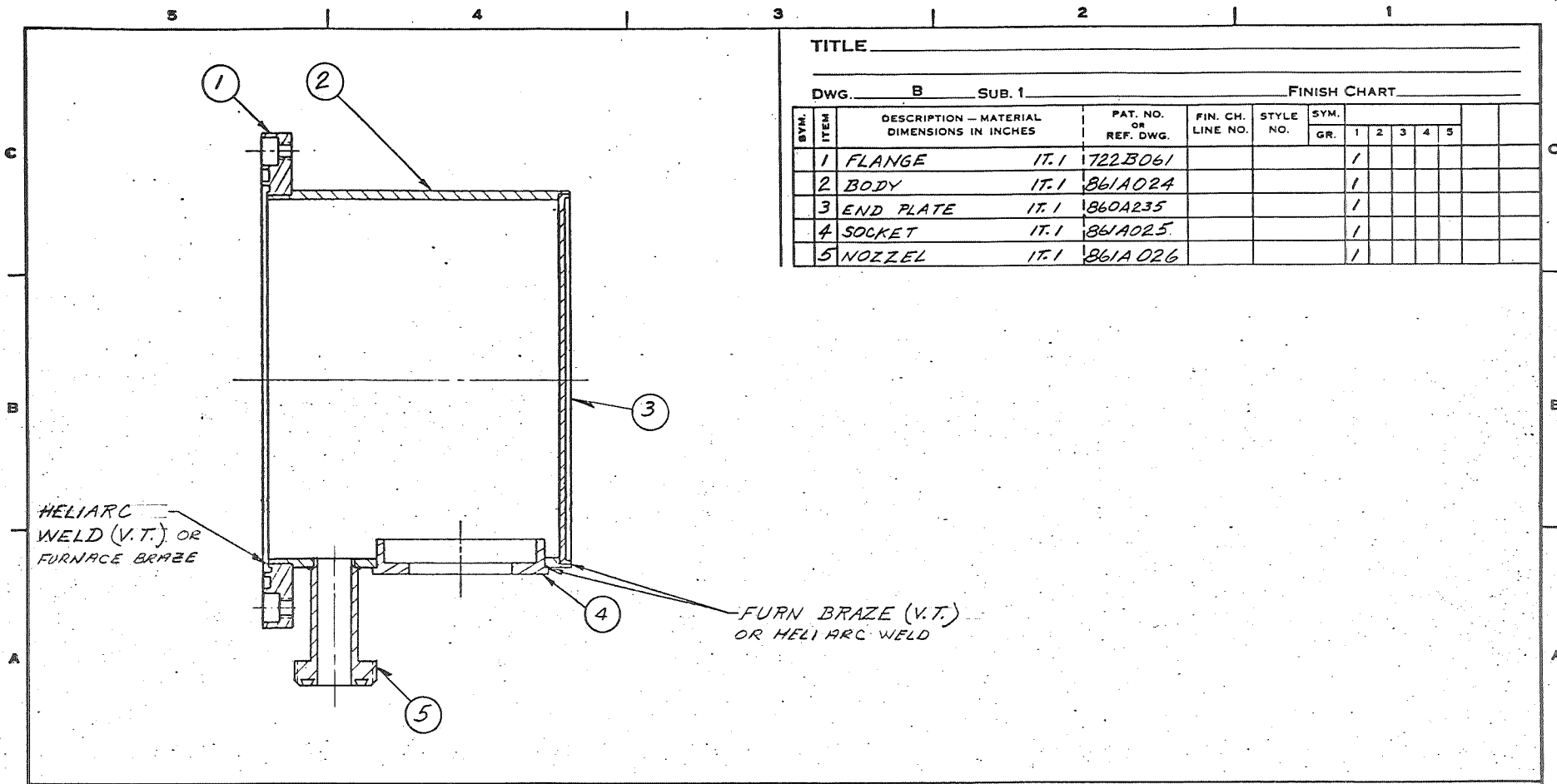

TITLE _____

DWG. B SUB. 1 FINISH CHART

SYM. ITEM	DESCRIPTION - MATERIAL DIMENSIONS IN INCHES	PAT. NO. OR REF. DWG.	FIN. CH. LINE NO.	STYLE NO.	SYM.					
					GR.	1	2	3	4	5
1	FLANGE	IT.1 722B061			/					
2	BODY	IT.1 861A024			/					
3	END PLATE	IT.1 860A235			/					
4	SOCKET	IT.1 861A025			/					
5	NOZZEL	IT.1 861A026			/					

HELIARC
WELD (V.T.) OR
FURNACE BRAZE

FURN BRAZE (V.T.)
OR HELI ARC WELD

1
S.O. D. 76361A
CHANGE
IT.

TOLERANCES		
UNLESS OTHERWISE SPECIFIED		
2 PL. DEC.	3 PL. DEC.	ANGLES
±.02	±.005	±0.5°

FINISH TO BE ✓ UNLESS
OTHERWISE SPECIFIED

REV. 4857 D32

WESTINGHOUSE ELECTRIC CORPORATION

TITLE ZERO GRAVITY CRYSTAL GROWING
BASE ASSEMBLY

DIMENSIONS IN INCHES-DO NOT SCALE DRAWING SUB. 1

DTM. <u>T. Quagliari</u>	2-2 1970	APPD. <u>(SD)</u>
CHKD. <u>H. Ryden</u>	2-3 1970	APPD.
BUPV.		APPD.

722 B 238

RESEARCH LABORATORIES CHURCHILL BORO. PITTSBURGH 35, PA., U.S.A.

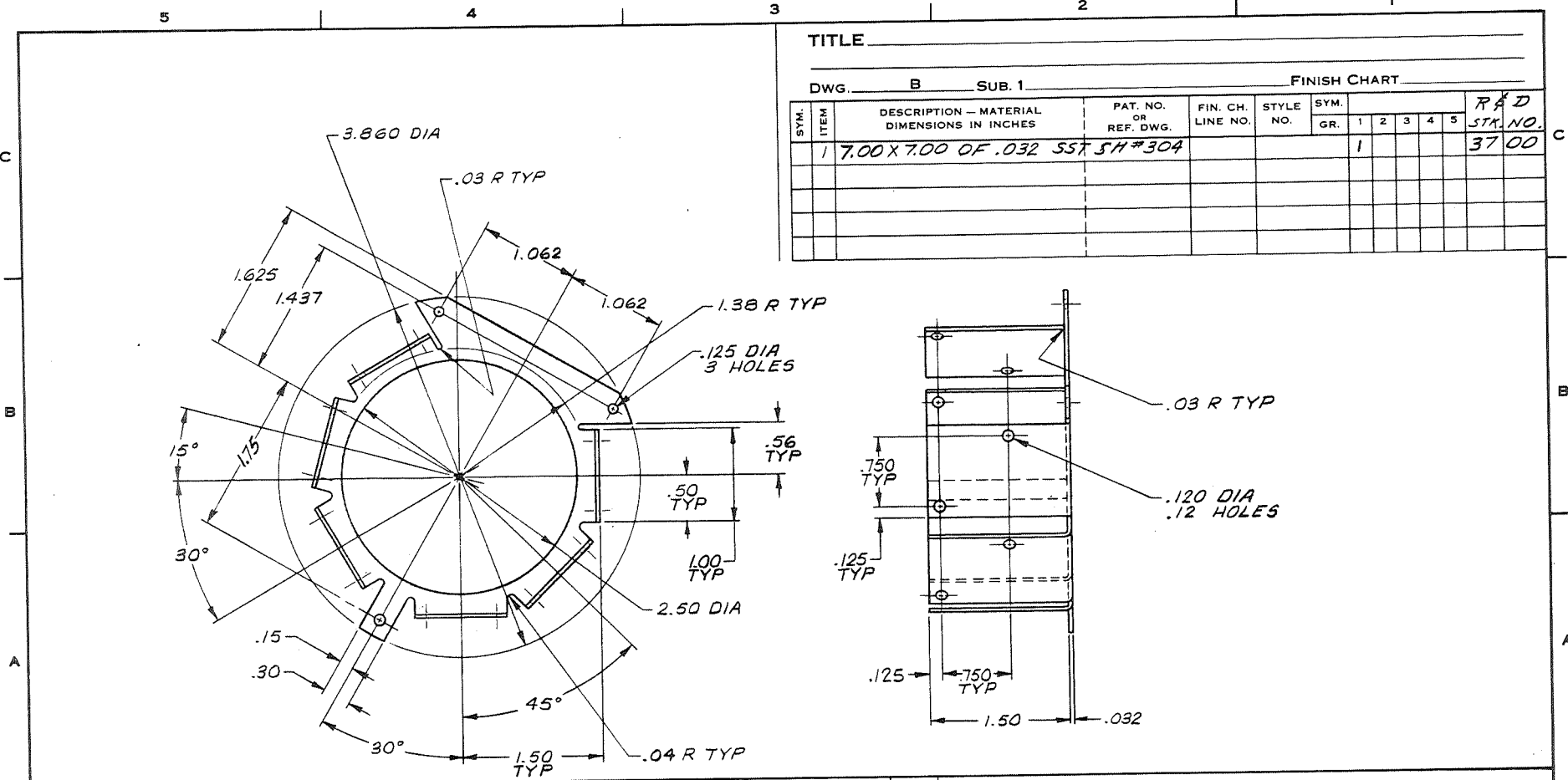

TITLE _____											
DWG. B SUB. 1 _____ FINISH CHART											
SYM. ITEM	DESCRIPTION - MATERIAL DIMENSIONS IN INCHES	PAT. NO. OR REF. DWG.	FIN. CH. LINE NO.	STYLE NO.	SYM. GR.	PAD					
						1	2	3	4	5	STR. NO.
1	7.00 X 7.00 OF .032 S57 SH #304				1						37 00

1	CHANGE
S.O. 7636/H	
D.	
IT.	

TOLERANCES		
UNLESS OTHERWISE SPECIFIED		
2 PL. DEC.	3 PL. DEC.	ANGLES
± .02	± .005	± 0.5°

FINISH TO BE ¹²⁵ UNLESS OTHERWISE SPECIFIED

WESTINGHOUSE ELECTRIC CORPORATION

TITLE ZERO GRAVITY CRYSTAL GROWING
MOUNTING PLATE DETAIL

DIMENSIONS IN INCHES—DO NOT SCALE DRAWING SUB. 1

DFTM. H. DUMAS	1/21/70	APPD. (LSD)			
CHKD. EZIGLER	1/22/70	APPD.			
SUPV.		APPD.			

722 B 239

RESEARCH LABORATORIES CHURCHILL BORO, PITTSBURGH 35, PA., U.S.A.

TITLE

DWG. C SUB. 1		FINISH CHART								
SYM. I.T.	DESCRIPTION - MATERIAL DIMENSIONS IN INCHES	PAT. NO. OF REF. DWG.	FIN. CH. LINE NO.	STYLE NO.	SYM. GR.					
					1	2	3	4	5	
1	I.T. 1	721 B928								
2	I.T. 1	859A781								
3	I.T. 1	859A780								
4	I.T. 1	721 B948								
5	I.T. 1	859A833								
6	I.T. 2	859A780					3			
7	I.T. 1	859A782								
8	I.T. 1	721 B932								
9	I.T. 1	859A804								
10. 086-56 x .12 LG. PAN HD. MACH. SCR. SS T.										3

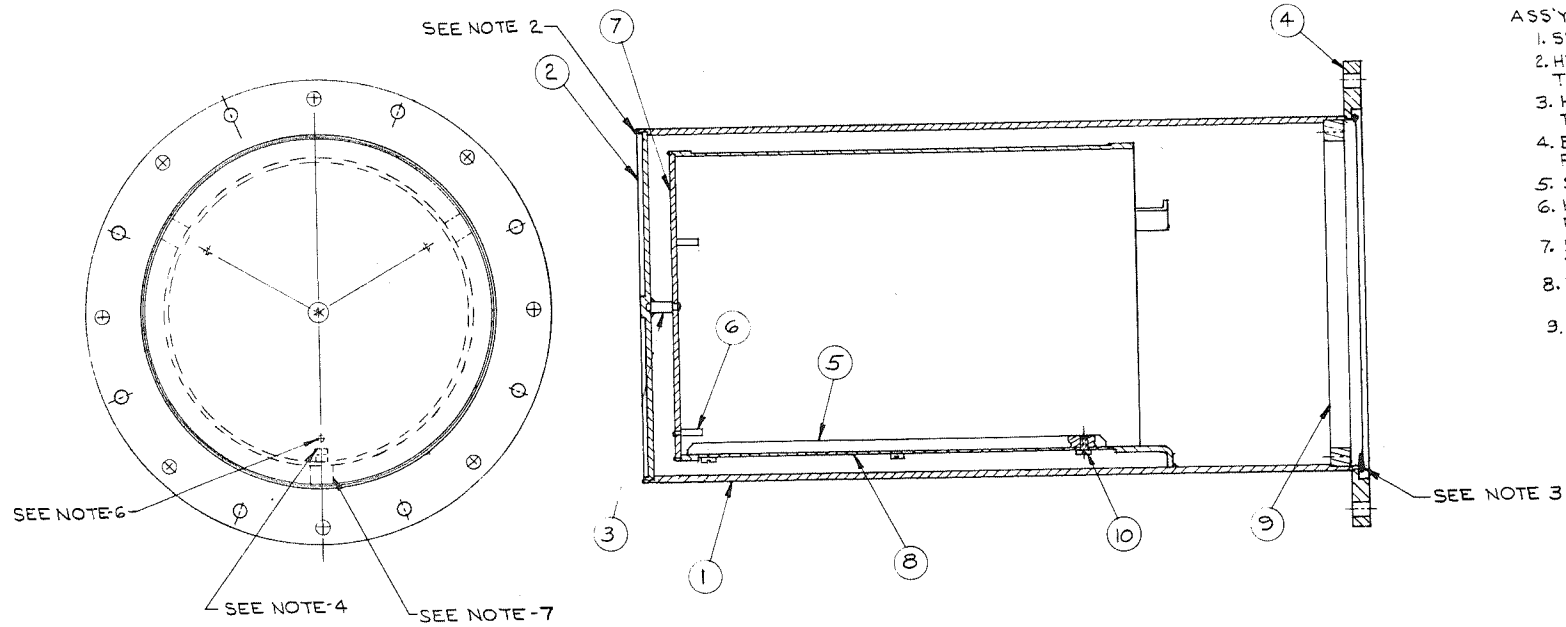

- ASS'Y. NOTES:
1. SPOT WELD I.T. 3 TO I.T. 2
 2. HELI-ARC I.T. 2 TO I.T. 1, WELD TO BE VACUUM TIGHT.
 3. HELI-ARC I.T. 4 TO I.T. 1, WELD TO BE VACUUM TIGHT.
 4. BRAZE I.T. 5 TO I.T. 8 IN POSITION AS SHOWN.
 5. SPOT WELD I.T. 6 TO I.T. 7.
 6. HELI-ARC I.T. 7 TO I.T. 8 IN POSITION AS SHOWN.
 7. BRAZE I.T. 8 TO I.T. 1 IN POSITION AS SHOWN.
 8. FURNACE BRAZE I.T. 9 TO I.T. 1 AS SHOWN.
 9. TACK WELD ITEM 10 TO ITEM 8 AFTER ASSEMBLY

1
S. O. CHANGE
D. 763614
I.T.

TOLERANCES UNLESS OTHERWISE SPECIFIED		
± PL. DEC.	± PL. DEC.	ANGLES
± .02	± .005	± 0.5°

FINISH TO BE ✓ UNLESS OTHERWISE SPECIFIED

REV. 4857D 32

WESTINGHOUSE ELECTRIC CORPORATION

TITLE ZERO GRAVITY CRYSTAL GROWING HOUSING SUB-ASS'Y

DIMENSIONS IN INCHES—DO NOT SCALE DRAWING SUB. 1

DFTM. W.C.S.	8206	APPD. <i>CS</i>	
CHKD. H.R.	82663	APPD.	253 C 464
SUPV.		APPD.	

RESEARCH LABORATORIES CHURCHILL BOND, PITTSBURGH 33, PA., U.S.A.

7 6 5 4 3 2 1

TITLE _____

DWG. **C SUB. 1** FINISH CHART

SYM.	IT.	DESCRIPTION - MATERIAL DIMENSIONS IN INCHES	PAT. NO. OR REF. DWG.	FIN. CH. LINE NO.	STYLE NO.	SYM. GR.				
						1	2	3	4	5
1		IT.1	721 B952			1				
2		IT.1	721 B926			3				
3		IT.1	721 B922			3				

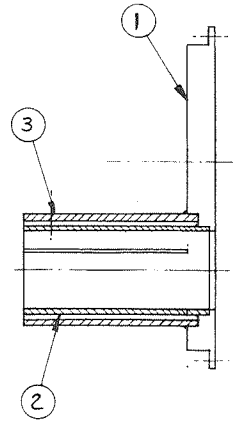
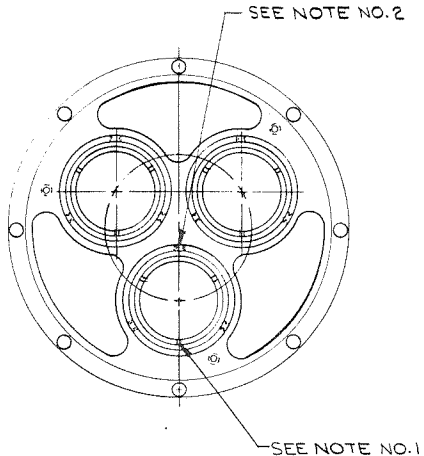

BRAZE NOTES:
 1. SLOT IN IT.2 TO BE POSITIONED AS SHOWN.
 2. TAPPED HOLE IN IT.3 TO BE LOCATED OPPOSITE SLOT IN IT.2 AS SHOWN.

SO. CHANGE
 D. 763614
 IT. 1

TOLERANCES		
UNLESS OTHERWISE SPECIFIED		
2 PL. DEC.	3 PL. DEC.	ANGLES
± .02	± .005	± 0.5°

FINISH TO BE ✓ UNLESS OTHERWISE SPECIFIED

DWG. 253 C 466

WESTINGHOUSE ELECTRIC CORPORATION

TITLE **ZERO GRAVITY CRYSTAL GROWING ALIGNMENT PLATE SUB-ASS'Y.**

DIMENSIONS IN INCHES—DO NOT SCALE DRAWING

SUB. 1

DTM. W.C.S.	8-19-69	APPD. <i>PSD</i>
CHRD. H.R.	8-26-69	APPD.
SUPV.		APPD.

253 C 465

7 6 5 4 3 2 1

7

6

5

4

3

2

1

TITLE

DWG. C SUB. 1 FINISH CHART

SYM. ITEM	DESCRIPTION - MATERIAL DIMENSIONS IN INCHES	PAT. NO. OR REF. DWG.	FIN. CH. LINE NO.	STYLE NO.	SYM. GR.	FINISH CHART				
						1	2	3	4	5
1	GR. 1	722B216			3					
2	GR. 1	721B919			3					
3	GR. 1	721B920			3					
4	GR. 1	721B942			1					
5	I.T. 1	860A250			3					
6	GR. 1	721B960			1					
7	GR. 1	253C465			1					
8	I.T. 1	859A806			3					
9	.112-40 X .375 LG. OVAL PT. SOC. SET SCR. S.S.T.				3					
*10	HEATER WIRE				1					
11	.086-56 X .187 LG. RD. HD. MACH SCR. S.S.T.				9					

12. QUARTZ FELT INSULATION

13. HEAT CONDUCTING ROD

14. .250 S.S.T. LOCKWASHER

15. .250 STD. S.S.T. HEX NUT

* TO BE SUPPLIED BY ENGINEERING

359 A 906

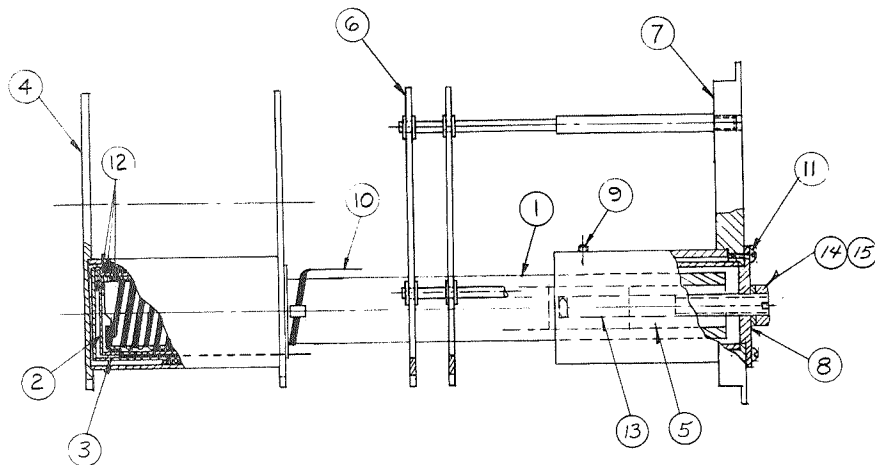

1

S. O.
D. 763614
CHANGE
IT.

TOLERANCES		
UNLESS OTHERWISE SPECIFIED		
2 PL. DEC.	3 PL. DEC.	ANGLES
±.02	±.005	±0.5°

FINISH TO BE ✓ UNLESS OTHERWISE SPECIFIED

REV. 4857D.32

WESTINGHOUSE ELECTRIC CORPORATION

TITLE ZERO GRAVITY CRYSTAL GROWING
QUARTZ CAPSULE SUB-ASS'Y.

DIMENSIONS IN INCHES-DO NOT SCALE DRAWING SUB. 1

DPTH. Y.C.S.	8-20	APPD.	CSJ	
CHKD. HR.	5-20	APPD.		253 C 466
SUPV.	69	APPD.		

RESEARCH LABORATORIES CHURCHILL BORO. PITTSBURGH 35, PA., U.S.A.

R 1722 DM-3

7 | 6 | 5 | 4 | 3 | 2 | 1

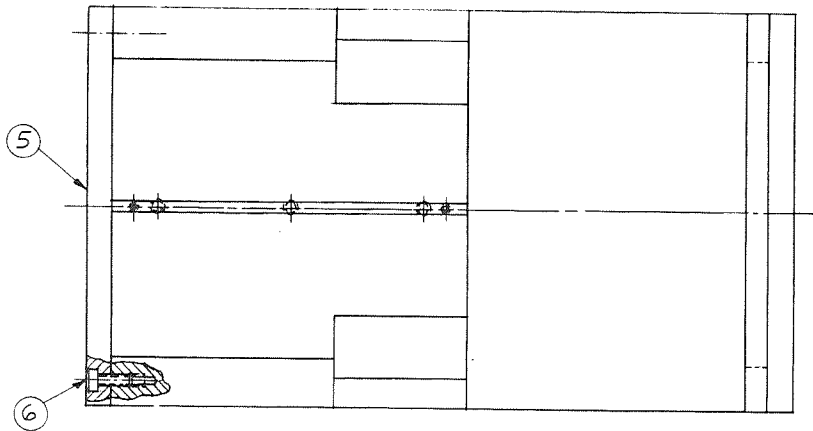

1	IT. 1	253C506	
2	IT. 1	722B004	
3	IT. 1	722B005	
4	IT. 1	859A982	
5	IT. 1	859A983	
6	.138-32 x .38 LG. SOC. HD. CAP SCR. ST.		9
7	.086-56 x .38 LG. SOC. HD. CAP SCR. ST.		2
8	.125 DIA. x .38 LG. DOWEL PIN ST.		1

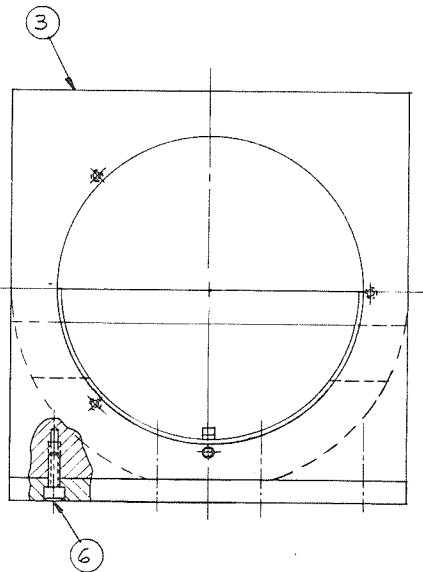
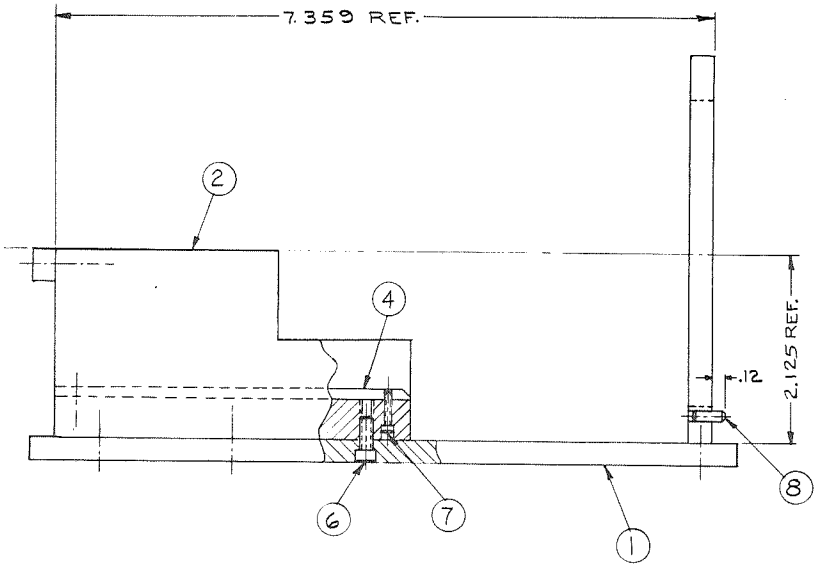

SO. 1
D. 763614
IT. CHANGE

WESTINGHOUSE ELECTRIC CORPORATION
TITLE ZERO GRAVITY CRYSTAL GROWING
FIXTURE ASSEMBLY

DIMENSIONS IN INCHES—DO NOT SCALE DRAWING		SUB. 1
DFTM. W.C.S.	9469	APPD. JLD
CHKD. R		APPD.
SUPV.		APPD.
		253C505

1 4.62 x 8.12 OF .25 THK. TOOL ST. OIL HARD 1

REF ID
STK NO.
40 16

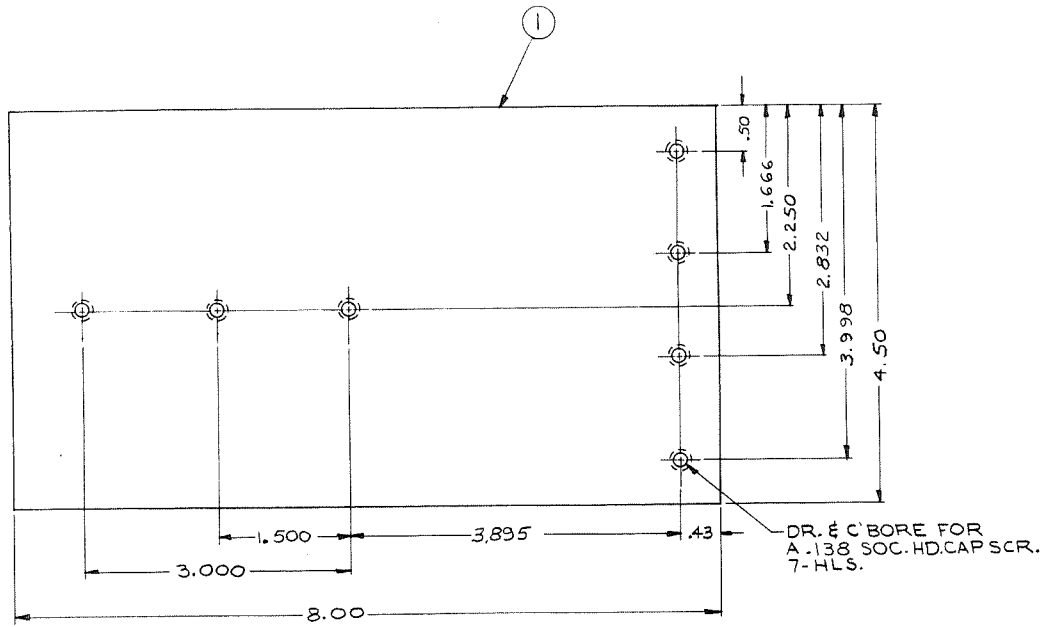

1
S. O.
D. 763614
CHANGE
II.

REF. 253C505

WESTINGHOUSE ELECTRIC CORPORATION

TITLE ZERO GRAVITY CRYSTAL GROWING
BASE PLATE DETAIL

DIMENSIONS IN INCHES—DO NOT SCALE DRAWING		SUB. 1	
DPTM. W.C.S.	D. 46	APPD. J. D.	
CHKD. R		APPD.	253C506
BUFV.		APPD.	

RESEARCH LABORATORIES CHURCHILL BORO. PITTSBURGH 39, PA., U.S.A.

7

6

5

4

3

2

1

R 1722-8

PARKER SEAL CO LEXINGTON KENTUCKY
 * GEO. C MARSHALL SPACE FLIGHT CENTER
 O TEXAS INSTRUMENT CO.

TITLE											
DWG. D SUB. 1 FINISH CHART											
SYM	LINE NO.	QTY	1	2	3	4	5	6	7	8	9
1	GR. 1	253C464									
2	GR. 1	253C464									
3	BASE ASSY	GR. 1 722B238									
4	PLATE	IT-1 861A047									
5	CAPTIVE SCR.	IT# 1 860A130									
6	CAPTIVE SCR.	IT# 2 860A130									
7	CAPTIVE WASHER	IT# 1 860A131									
8	CAPTIVE WASHER	IT# 2 860A131									
9	O-RING CAT NO 2-156	VITON (77545 COMPOUND)									
10	O-RING CAT NO 2-112	VITON (77545 COMPOUND)									
11	SPACER	IT-1 861A027									
12	SPACER	IT-1 861A028									
13	MTG PLATE	IT-1 722B239									
14	CAP	IT-1 861A029									
15	PLUG	IT-1 861A030									
16	MTG PLATE	IT1 861A031									
17	THERMOSTAT TEXAS INST. NO. 11041-32										
18	RECEPTACLE AMPHENOL #48-13H16-24PN-N										
19	REF JUNCTION										
20	MACH SCR .112-40 X .12 LG PAN HD S5T										
21	250-80 X .12 LG PAN HD S5T MACH SCP										
22	MACH SCR .112-40 X .25 LG PAN HD S5T										
23	MACH SCR .112-40 X .42 LG PAN HD S5T										
24	NUT .112-40 HEX S5T										
25	MACH SCR .112-40 X .25 LG PAN HD S5T										
26	NUT .112-40 HEX S5T										
27	WASHER .112 REG										
28	NUT .138-92 HEX S5T HEX NUT STD										

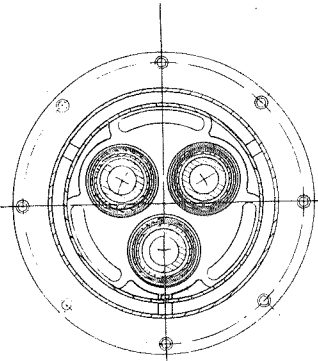

SECTION A-A

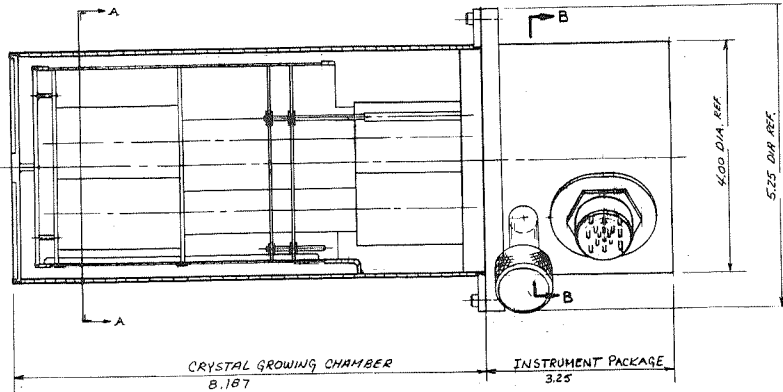

CRYSTAL GROWING CHAMBER 8.187
INSTRUMENT PACKAGE 3.825

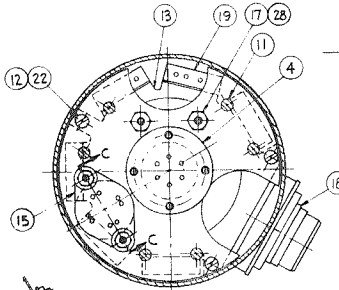

SECTION B-B

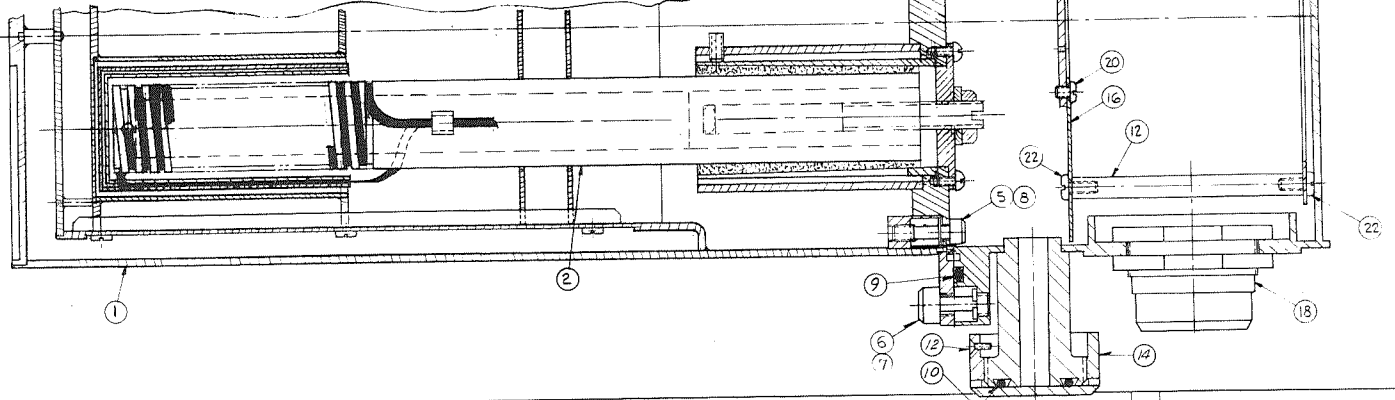

SECTION C-C

1
 1763 674
 CHANGE

TOLERANCES		
UNLESS OTHERWISE SPECIFIED		
1/16" TO 1/8"	±.005	±0.01"
1/8" TO 1/4"	±.003	±0.005"

FINISH TO BE UNLESS OTHERWISE SPECIFIED

WESTINGHOUSE ELECTRIC CORPORATION
 TITLE ZERO GRAVITY CRYSTAL GROWING
 GENERAL ASSEMBLY
 DIMENSIONS IN INCHES - DO NOT SCALE DRAWING
 SUB. 1
 DESIGNED BY C.W.L. CHECKED BY H.K.
 DRAWN BY H.K.
 4857D 32
 RESEARCH LABORATORIES, PITTSBURGH, PENNSYLVANIA, U.S.A.

SUB. S.O.	1	D-763614	AR	CSD					
-----------	---	----------	----	-----	--	--	--	--	--

WESTINGHOUSE ELECTRIC CORPORATION RESEARCH LABORATORIES CHURCHILL BORO. PITTSBURGH 35, PA., U.S.A.

TITLE THERMOCOUPLE CLAMP.

DWG. A SUB. 1 FINISH CHART

SYM.	ITEM	DESCRIPTION - MATERIAL DIMENSIONS IN INCHES	PAT. NO. OR REF. DWG.	FIN. CH. LINE NO.	STYLE NO.	SYM.				
						GR.	1	2	3	4
	1	FROM .005 THK 304 SST.				1				
	2	.086-56 X 1" LG SST FIL HD. MCH. SCR.				2				
	3	.086-56 SST HEX NUT				2				

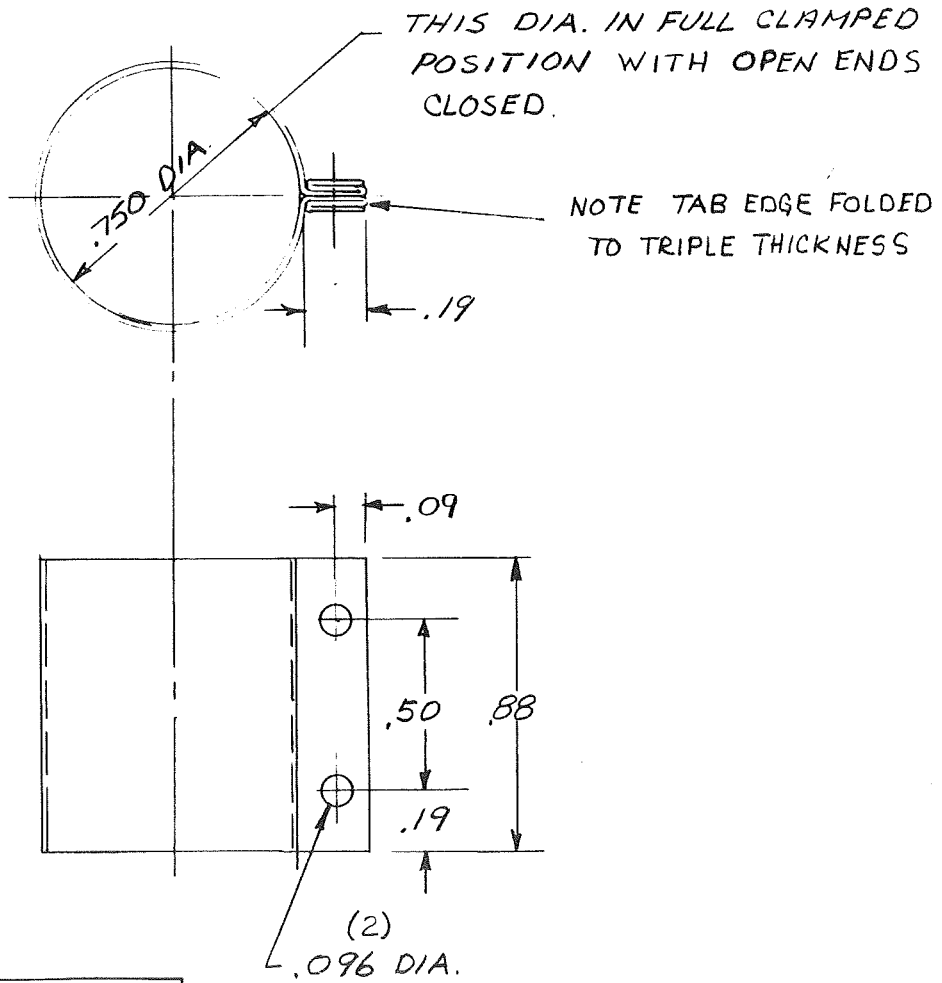

TOLERANCES		
UNLESS OTHERWISE SPECIFIED		
2 PL. DEC.	3 PL. DEC.	ANGLES
±.02	±.005	±0.5°

861 A 149

Curve 592548-B

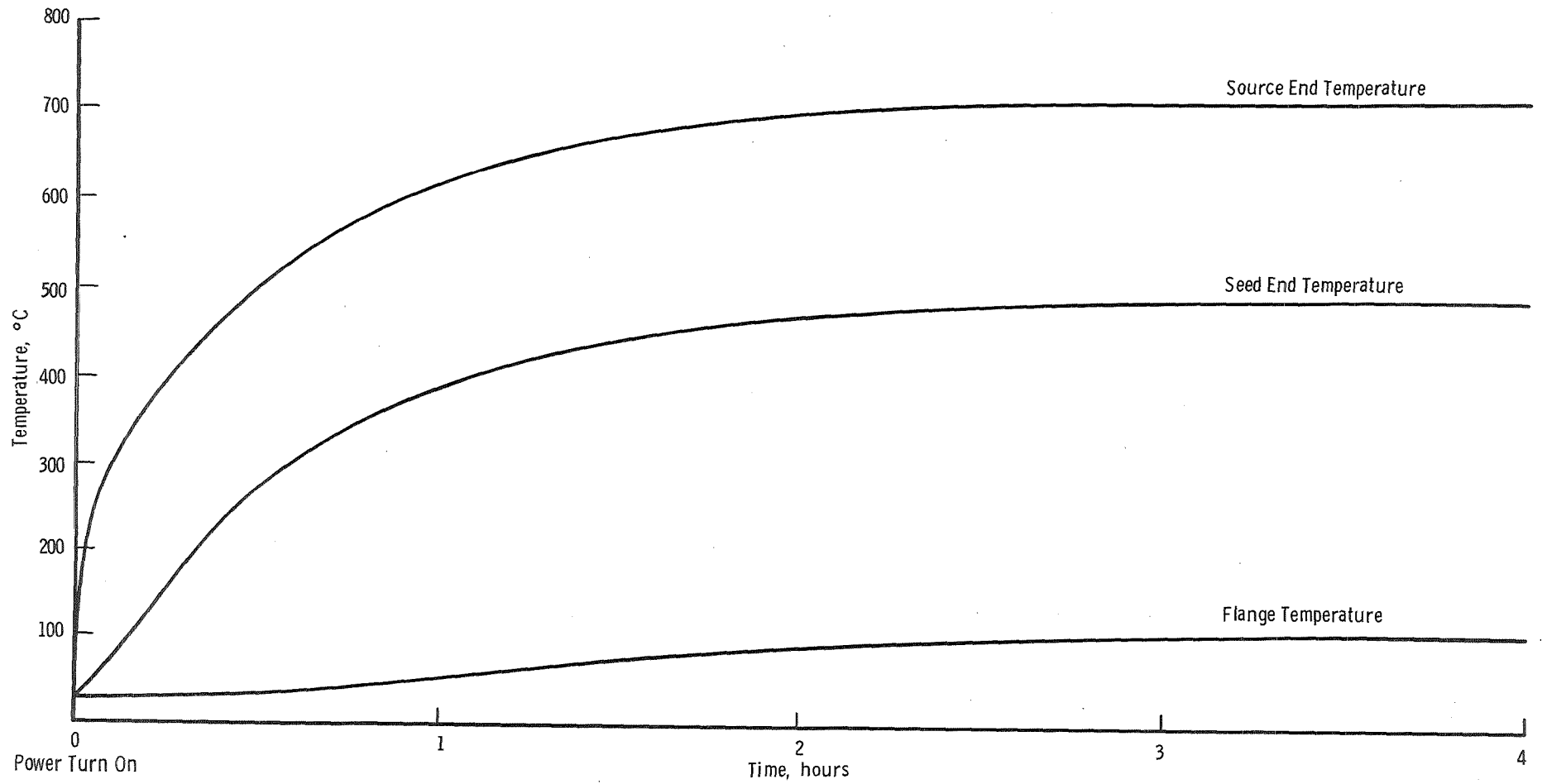

Fig. 1—Rate of heating

Curve 592549-B

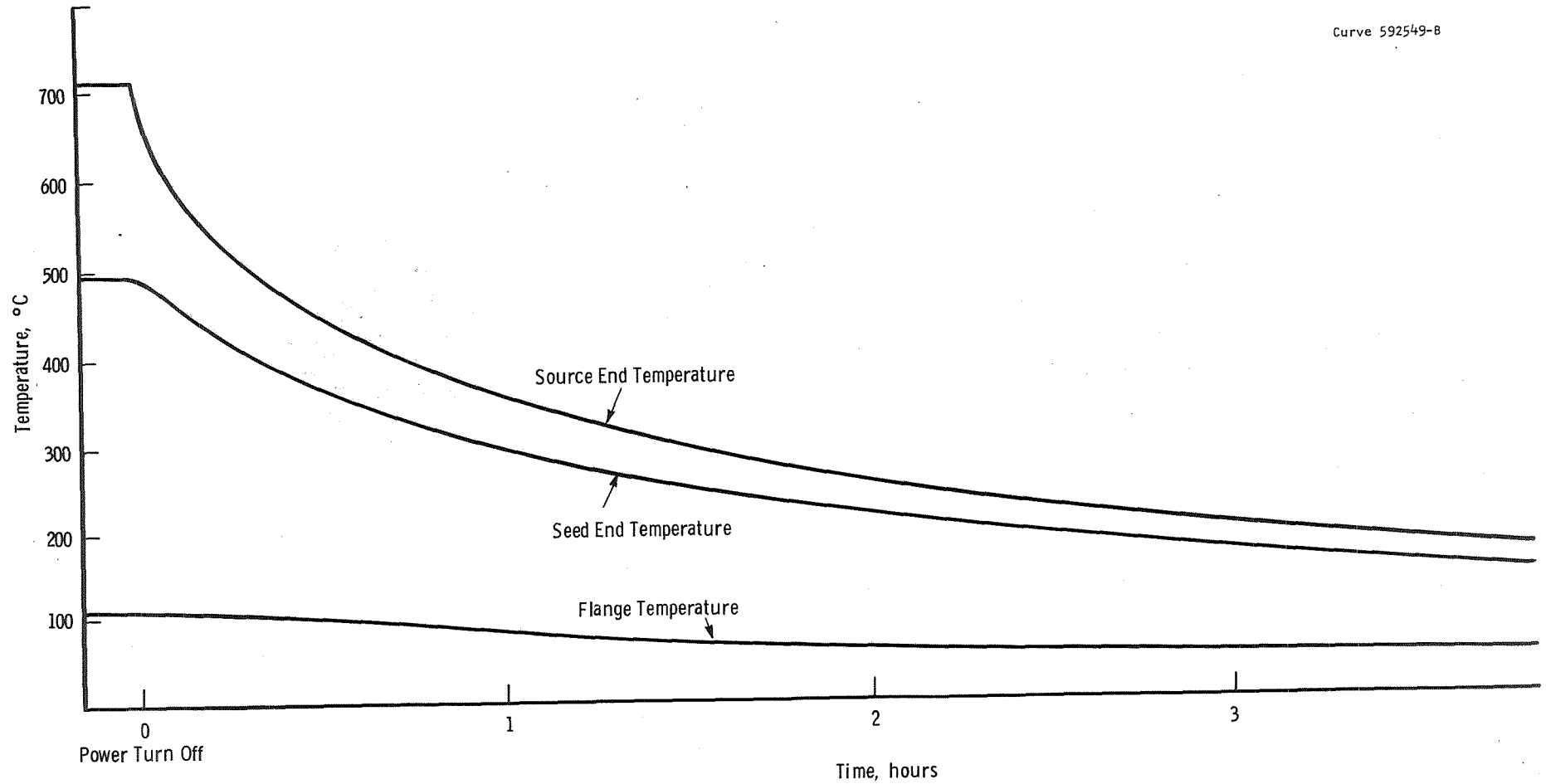

Fig. 2—Rate of cooling