

STUDY OF LONG-TERM ATMOSPHERIC TRACE CONTAMINANT MONITORING AND CONTROL

Final Report to

NASA MANNED SPACECRAFT CENTER
HOUSTON, TEXAS

NAS 9-10434

C-72206

by

Philip L. Levins
James E. Oberholtzer

May 24, 1970

FACILITY FORM 602	N70-34327	(ACCESSION NUMBER)	(THRU)
	91	(PAGES)	1
	CR-108507	(NASA CR OR TMX OR AD NUMBER)	05
			(CATEGORY)



Arthur D Little, Inc.

Reproduced by
**NATIONAL TECHNICAL
 INFORMATION SERVICE**
 Springfield, Va. 22151

PRECEDING PAGE BLANK NOT FILMED.

FOREWORD

This project was initiated in the Crew Systems Division because of the need for information on spacecraft atmospheric quality during projected long-term missions. We wish to acknowledge the helpful assistance of Mr. Stanley Luczkowski of the Biomedical Instrumentation group, who was the technical monitor for this project. We also wish to acknowledge the guidance provided in many interesting discussions with Dr. Elliott Harris, Mr. Wayland Rippstein, Mr. Noel Willis, and Mr. Robert Cusik — all of NASA, Houston.

Dr. James E. Oberholtzer assumed principal responsibility at Arthur D. Little, Inc., for accomplishing the objectives of this program. The project was under the program management of Dr. Philip L. Levins. Major contributions to this report were made by Dr. James R. Aronson, Mr. Laurence Lorah, Dr. Robert C. Reid, Dr. Alfred E. Wechsler, and Dr. Laurence R. Young.

TABLE OF CONTENTS

	Page
List of Figures	ix
List of Tables	xi
I. PURPOSE AND SCOPE	1
II. CONCLUSIONS AND RECOMMENDATIONS	3
III. SOURCES OF TRACE CONTAMINANTS	5
IV. STRUCTURE AND POTENTIAL SOURCES OF CONTAMINATION OF THE BASELINE ETC/LSS	7
A. ATMOSPHERIC REVITALIZATION GROUP	7
B. THERMAL CONTROL GROUP	11
C. WATER AND WASTE MANAGEMENT GROUP	11
V. PHILOSOPHY OF TRACE CONTAMINANT MONITORING	13
A. OVERALL AIR QUALITY	13
B. RAPID MEASUREMENT OF SELECTED SPECIES	14
VI. DETECTION TECHNIQUES	17
A. GAS CHROMATOGRAPHY	18
B. MASS SPECTROMETRY	18
C. OPTICAL SPECTROMETRY	19
1. General Principles	19
2. Ultraviolet-Visible	19
3. Infrared	21
4. Microwave	23

TABLE OF CONTENTS (Continued)

	Page
VI. DETECTION TECHNIQUES (Continued)	
5. Raman	24
6. Emission	25
D. ELECTROCHEMICAL DETECTORS	26
1. Conductometry	26
2. Potentiometry	27
3. High-Temperature Concentration Cell	27
4. Polarographic Sensors	28
5. Conclusions	28
VII. DETAILED CONSIDERATION OF RECOMMENDED TECHNIQUES	29
A. GAS CHROMATOGRAPHY-MASS SPECTROMETRY (GCMS)	29
1. Gas Chromatography (GC)	30
2. GCMS Interface	37
3. Mass Spectrometer	39
4. Data Collection and Processing	51
5. Conclusions	52
B. INFRARED CORRELATION SPECTROMETRY/ INTERFEROMETRY	52
1. Principles of Correlation	52
2. Methods of Correlation Spectrometry/ Interferometry	53

TABLE OF CONTENTS (Continued)

	Page
VII. DETAILED CONSIDERATION OF RECOMMENDED TECHNIQUES (Continued)	
3. Sensitivity	57
4. Spectral Considerations	59
5. Conclusions	67
VIII. EXTENDING THE LIFETIME OF THE CANDIDATE TECHNIQUES	69
IX. METHODS OF PRESENTING INFORMATION TO THE CREW	71
A. DESCRIPTION OF THE ONBOARD CHECKOUT SYSTEM	71
B. TASKS TO BE PERFORMED BY THE ONBOARD CHECKOUT SYSTEM	71
1. Automatic Checkout of the Trace Contaminant Monitoring System (TCM)	73
2. Logging and Manipulation of TCM Measurements	73
3. Crew Information Presentation	75
X. FEEDBACK OF INFORMATION FOR CORRECTIVE ACTION	79
REFERENCES	81

PRECEDING PAGE BLANK NOT FILM'D.

LIST OF TABLES

Table No.		Page
1	Potential Contaminants of High Toxicity	15
2	Electromagnetic Energy Spectrum	20
3	Boiling Points and MAC's of Contaminants Observed in Spacecraft Atmospheres	32
4	Mass Spectrometry Characteristics of High-Molecular-Weight Contaminants	40

LIST OF FIGURES

Figure No.		Page
1	Contaminant Control Subsystem	9
2	Ultraviolet Spectrum of Sulfur Dioxide	20
3	Infrared Spectrum of Methane	22
4	Schematic Representation of a Gas Chromatograph-Mass Spectrometry System	30
5	Electron Impact and Field Ionization Spectra of n-Heptane	42
6	Schematic Drawing of Quadrupole Filter	45
7	Single-Focusing Magnetic Sector Analyzers	46
8	Double-Focusing Ion Optics	48
9	Comparison of Single- and Double-Focusing Spectrometers with the Same Dispersion	50
10	Schematic of Correlation Spectrometer	55
11	Schematic of Correlation Interferometer	58
12	Infrared Spectrum of HCl	64
13	Infrared Spectra of COF ₂ and COCl ₂	65
14	Infrared Spectrum of Human-Expired Air	68
15	Simplified Diagram of the OCS	72
16	Prediction of Trace Contaminant Concentration	74
17	Calculation of Body Concentrations of a Contaminant	76

I. PURPOSE AND SCOPE

As space missions of longer duration become feasible, the safety of the crew is a matter of growing concern because of the possible effect of trace contaminants in the spacecraft atmosphere. Vehicle leakage rates to space are being reduced to satisfy the requirements of longer missions, but as a result the likelihood of trace contaminant buildup has become markedly greater. The fact that the crew will be exposed to the spacecraft atmosphere continuously for 90 and perhaps eventually 1000 days makes it imperative that trace contaminants be properly controlled and monitored.

To meet the needs of future extended missions, the NASA Manned Spacecraft Center has an ongoing program for the development of a Baseline Environmental/Thermal Control and Life Support System (ETC/LSS) which will maintain a habitable atmosphere and process waste materials. Included in the ETC/LSS is a subsystem for controlling trace contaminants in the spacecraft atmosphere.

The operation of the trace contaminant control system must be monitored by instruments that measure the amount of contaminants in the atmosphere during the mission. The specific purpose of this program was to study devices and/or techniques that can perform this function. The specific tasks involved in the program were to:

- Review the proposed MSC Baseline ETC/LSS to identify potential contaminants.
- Survey existing detection methods or instrumentation capable of monitoring atmospheric trace contaminants.
- Review problems associated with the extension of the lifetime of candidate existing devices.
- Consider improved methods of presenting contaminant monitor information to the crew.
- Review and recommend approaches for interfacing the detection devices with the ETC/LSS to provide positive corrective action.

This report describes the findings and recommendations which resulted from performing the above tasks. These results delineate further research effort which is needed to define the requirements for future hardware development to provide trace contaminant monitoring.

II. CONCLUSIONS AND RECOMMENDATIONS

We have concluded that at the present state of knowledge of spacecraft contaminants, their long-term toxicity, and the environmental control subsystems, a complete analysis of the spacecraft atmosphere is required to provide an adequate measure of atmospheric quality.

Ideally, a trace contaminant monitor (TCM) would provide continuous, instantaneous information on all contaminants in the spacecraft atmosphere. Rapid response is necessary to provide sufficient warning if dangerous contamination occurs, and a complete absolute analysis is required because of the great number of known and unknown trace contaminants present in the spacecraft atmosphere.

Unfortunately, at the present stage of development of analytical techniques it is impossible to obtain the ability for both rapid response and a complete analysis of all contaminants in a single instrument. Therefore, we recommend that two independent subsystems be developed for analysis — an intermittent contaminant monitor (ICM) and a continuous contaminant monitor (CCM). Each would complement the other.

The ICM should be capable of measuring the level of each trace contaminant and identifying and measuring unexpected, unknown contaminants which might appear.

A CCM is required because of the present limitations with respect to response time and number of locations that can be sampled. It should perform its measurement at or near the suspected source of the given contaminant. The CCM should provide fast-response measurements for a few preselected contaminants associated with specific hazards or malfunctions, particularly the following:

- Component overheating and/or incipient fire,
- Failure of an onboard experiment, and
- Malfunction of the catalytic oxidizer system.

Within the present state of the art, the only device which appears capable of serving as an ICM is a gas chromatograph-mass spectrometer (GCMS). We recommend that the GCMS developed by the Jet Propulsion Laboratory for the Viking mission be adapted to, and optimized for, this application. In particular, the following areas should be studied:

- (1) *Sample Introduction*— The possibility of thermoelectrically cooling the beginning of the gas chromatograph column should be studied to improve sample collection and enhance resolution.
- (2) *Gas Chromatograph Column Selection*— Particular emphasis should be placed on the type of column and the nature of the stationary phase and support.
- (3) *Gas Chromatograph-Mass Spectrometer Interface*— Consideration should be given to contamination problems, throughput, and retention of sample integrity.
- (4) *Mass Spectrometry*— The dual ionization and chemical ionization sources should be fully evaluated. A detailed trade-off study should be made of single- and double-focusing and quadrupole analyzers.

With regard to the CCM, infrared correlation spectrometry is the most promising method now available. It has a rapid response time and can be used for remote detection. It appears to have the best potential for measuring the kinds of chemical species that indicate the quality of the spacecraft atmosphere. Additional theoretical and experimental studies should be performed to determine:

- Whether dispersive or interferometric correlation should be used,
- The specificity and sensitivity of the technique,
- The extent of interference by other gases present in normal and emergency atmospheres, and
- The feasibility of using new correlation approaches to minimize interference problems.

III. SOURCES OF TRACE CONTAMINANTS

The trace contaminant monitoring system should warn of an ETC/LSS malfunction and, if possible, provide information for corrective action. To truly safeguard the crew, however, its role should be broader than this; it should indicate the presence of dangerous levels of any potential contaminants, not only those associated with the ETC/LSS but also those from the following two sources:

- (1) *Fires and Overheatings:* Although fire detection *per se* is not within the scope of this work, a number of highly toxic compounds (CO, COF₂, COCl₂, HCl, and HF) can originate from fires or overheating of materials in contact with organic compounds. Large quantities could be produced in a short time, so it is imperative that they be detected quickly at their source before the entire cabin becomes contaminated. In effect, then, the detection of incipient fires and the monitoring of trace contaminants are quite inseparable.

- (2) *On-Board Experiments:* Some very toxic species might arise from possible on-board experiments[1]. We have not been able to determine whether experiments that could release species such as the hydrazines, HCl, HF, and SO₂ are still planned for the orbiting laboratory; but if the possibility of producing such highly toxic compounds remains as the experiments are more clearly defined, facilities for monitoring those species at their potential source should be implemented. It would be highly desirable to pipe ventilation directly through the contaminant control system.

IV. STRUCTURE AND POTENTIAL SOURCES OF CONTAMINATION OF THE BASELINE ETC/LSS

The MSC Baseline Environmental/Thermal Control and Life Support System consists of three major subsystems: an atmospheric revitalization group, a thermal control group, and a water and waste management group. For this study, we have considered in detail only those components which can directly affect the production or removal of trace contaminants from the spacecraft environment. There is a minor chance of contamination from the thermal control group, and a definite problem arises in the collection of feces and urine on the waste management group; but the major source of contaminants is from the atmospheric revitalization group.

This section describes the functions and structure of the three subsystems and examines the ways in which they might contaminate the cabin atmosphere.

A. ATMOSPHERIC REVITALIZATION GROUP

The atmospheric revitalization group consists of six principal subsystems, one for each of the following functions:

- Atmospheric supply
- Pressure control
- Contaminant control
- Carbon dioxide removal
- Water electrolysis
- Sabatier reaction

The *atmospheric supply subsystem* controls the amount of oxygen and nitrogen in the spacecraft environment. It makes up losses due to leakage or depressurization and provides long-term storage of the atmospheric constituents. Nitrogen for atmospheric supply will be stored as a sub-critical fluid outside the spacecraft cabin. Oxygen will be stored under high pressure and also made by the electrolysis of water. Unless contaminants find their way into the N₂ and O₂ supplies, the operation of this subsystem has little effect on trace contamination of the cabin environment.

The *pressure control subsystem* provides for proper partial pressure of oxygen in the cabin environment over the range of total gas pressure from 5 to 14.7 psia. This subsystem also has little effect on the trace contaminants in the cabin environment.

The *contaminant control subsystem* (Figure 1) is the most important part of the baseline system from the standpoint of trace contaminants. It has two major

components, a charcoal absorber and a catalytic oxidizer system; these two components are in separate flow circuits and are supplied with separate blowers.

In the charcoal sorption circuit, air from the cabin and gases evolved from the waste water management group pass first through a debris filter to remove large particles which may be suspended in the gas stream. The gas flow rate through the filter is approximately 370 cfm under the design pressure of 10 psi. The gas is then drawn through an activated charcoal bed, which removes most of the trace contaminants. The charcoal is impregnated with phosphoric acid to promote ammonia removal and is replaced by the astronaut at predetermined maintenance intervals. The gas then passes through a biological filter designed to remove particles as small as 0.3 micron. The filtered gas flows through a humidity and heat exchanger, which adjusts the gas stream to the desired humidity and temperature. Most of the gas then re-enters the cabin environment, and the rest goes to the carbon dioxide removal subsystem.

The flow path for the catalytic oxidizer circuit is currently being redesigned. Previously (as shown by the dashed lines in Figure 1), the catalytic oxidizer system flow was taken from the input to the CO₂ removal system and returned via the charcoal sorber inlet. Now, to permit variable flow through the oxidizer without upsetting flows in the remainder of the system, it has been isolated and provided with its own blower. Flowing at approximately 3 to 5 cfm, the air passes first through a small phosphoric-acid-impregnated charcoal bed, which removes ammonia and most halogenated hydrocarbons. (The presence of this bed is not definite, to our knowledge; but since NH₃ is susceptible to oxidation to N₂O and/or NO₂ in the oxidizer[2] and halocarbons poison the catalyst[3], its presence is highly desirable. The gas then enters a pre-absorbent bed of LiOH/Li₂CO₃, which removes acid gases that could poison the catalyst. It then enters a catalytic burner containing a supported palladium catalyst maintained at about 600°F. The primary role of the oxidizer is to remove H₂, CH₄, and CO by oxidation to H₂O and CO₂; however, sulfur-, nitrogen- and halogen-containing compounds that reach the oxidizer may also be oxidized, forming corrosive acid gases in the process. The effluent from the oxidizer passes through a second LiOH/Li₂CO₃ sorber prior to re-entering the cabin atmosphere.

Failure of the charcoal sorption circuit would result in a general increase in trace contaminant level, but no new toxic species would be produced. Failure modes for the catalytic oxidizer system are more complex and, unfortunately, are not completely understood because of insufficient experimental testing. Some possible cause-effect relationships are the following:

- If a halogenated compound or NH₃ passes through the proposed small charcoal bed preceding the oxidizer, it may reversibly poison the catalyst and/or produce toxic combustion products.

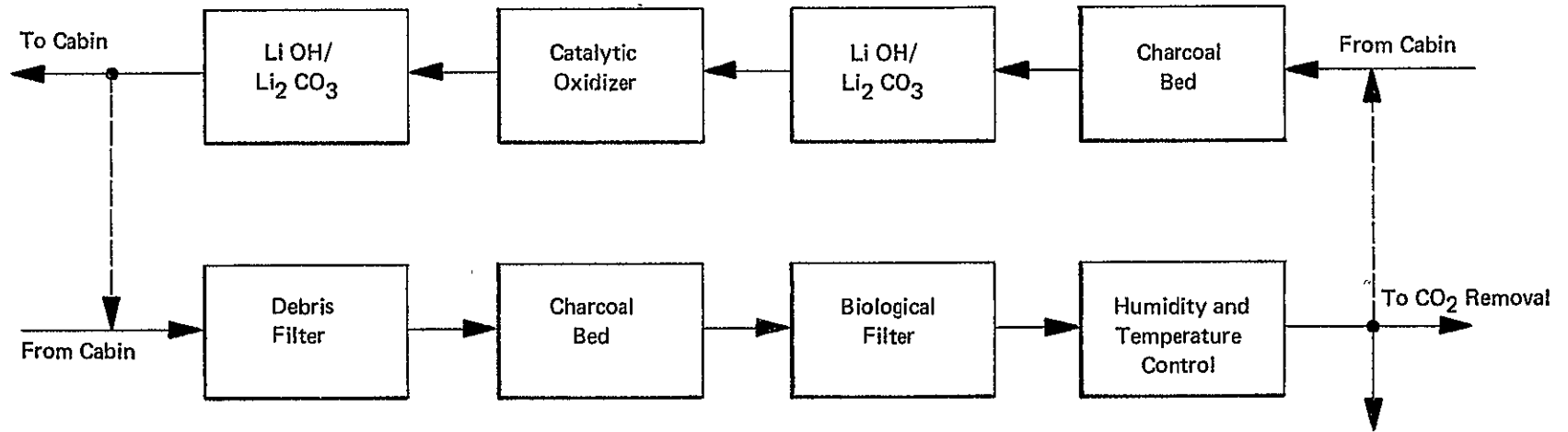

FIGURE 1 CONTAMINANT CONTROL SUBSYSTEM

- If sulfur- and nitrogen-containing compounds are not removed by the pre-chemisorbent, they may irreversibly poison the catalyst and necessitate its replacement; toxic oxidation products can result.
- Loss of oxidizer efficiency due to low temperature or catalyst poisoning may lead to formation of highly toxic, non-acid species that are not removed by the post-chemisorbent.[4]
- The most marked effect of a loss in oxidizer efficiency is a sharp drop in methane conversion.[3]
- Excessively high oxidizer temperatures can lead to the formation of NO_2 .[2]
- Failure of the post-chemisorbent bed would allow any toxic acid gases formed in the oxidizer to go directly into the cabin atmosphere.

The flow that enters the *carbon dioxide removal subsystem*, about 20 to 30 lb/hr, passes first through a silica gel bed to remove moisture and then through a molecular sieve bed to remove carbon dioxide; the conditioned air then re-enters the cabin. These beds may be thermally regenerated as part of the overall system operation. The carbon dioxide which is desorbed from the molecular sieve is stored in an accumulator for subsequent decomposition in the Sabatier reactor.

The *electrolysis subsystem* converts water from the waste water management systems to hydrogen and oxygen. The oxygen is used for the spacecraft atmosphere, and the hydrogen is reused in the Sabatier reactor. Leaks in the electrolysis cells or associated plumbing which contains hydrogen could produce potentially dangerous levels of hydrogen.

The carbon dioxide from the accumulator and hydrogen from the electrolysis unit enter a *Sabatier reactor subsystem*, where they are converted to water and methane. The water is condensed and returned to the waste water management system. Other products from the Sabatier reaction, including methane and residual carbon dioxide, may be either vented or used elsewhere in the spacecraft system. The Sabatier reactor has several heat exchangers, which use either water or the cabin environment gas as the heat exchange fluid. Leaks in the Sabatier reactor could increase methane levels.

Other components of the atmospheric revitalization group, such as heat exchangers, humidifiers, and pressure regulators, are of little importance as

sources of trace contaminants. Facilities to monitor temperature, humidity, total cabin pressure, oxygen partial pressure, and carbon dioxide partial pressure are included in the baseline environmental control system. Thus, carbon dioxide is not considered a trace contaminant in our analysis.

B. THERMAL CONTROL GROUP

The thermal control group regulates the temperature of the cabin atmosphere and many of the spacecraft components by means of heat exchange with water at various controlled temperatures. A solar absorber and space radiator on the exterior of the craft provide the heat source and sink, respectively. Heat exchangers outside the cabin compartment transfer heat from the organic liquids used in the radiators to water, which is the only heat transfer fluid used within the cabin itself.

The design of the thermal control group to permit the use of water as the only heat transfer fluid within the cabin compartment makes it highly unlikely that trace contaminants could be produced by this group. Non-aqueous fluids would be used in the solar collector and space radiator circuits, but they would be kept outside of the cabin proper. However, pumps in the collector and radiator circuits may need to be maintained periodically from within the cabin, and the fluids that they contain could cause trace contamination of the atmosphere at such times. Although we believe that final selection of these non-aqueous coolants has not been made, a type of freon has been proposed for the space radiator circuit.

C. WATER AND WASTE MANAGEMENT GROUP

The water and waste management group (WWMG) consists of components for collecting and processing feces, urine, wash water, and humidity condensate. Water reclamation is accomplished by distillation and reverse osmosis. Facilities for the sterilization and storage of reclaimed water and non-degradable solid wastes are provided.

An important feature of the WWMG is the use of positive gas flow to entrain feces and thereby permit defecation in a zero-g environment. This gas is separated from the feces and flush water, and subsequently passes to the trace contaminant control system for purification and release into the cabin atmosphere.

Significant amounts of gaseous contaminants, including ammonia and organic nitrogen and sulfur compounds, are associated with the collection of feces and urine. These contaminants are of particular importance, since the gas flows associated with excreta collection pass into the contaminant control system and then into the cabin atmosphere. It seems possible that during defecation, for example, the high concentrations of gaseous contaminants might not be completely removed by the contaminant control system.

V. PHILOSOPHY OF TRACE CONTAMINANT MONITORING

The primary role of a trace contaminant monitoring system is to ensure crew safety and performance by detecting the presence of any contaminant before it reaches potentially harmful levels. A representative sample of the cabin air would, of course, be analyzed; however, additional valuable information can be obtained by monitoring selected species in the vicinity of important sources and sinks of known contaminants. This supplementary information can be quite useful for predicting potentially rapid contaminant buildups and for suggesting corrective measures that need to be taken.

A. OVERALL AIR QUALITY

Some two hundred possible trace contaminants have been identified in various closed atmospheres.[1,5] On the basis of toxicity, the maximum allowable concentrations (MAC) vary by more than four orders of magnitude, from 1000 to well under 0.1 mg/m^3 . The contaminants exist in an atmosphere of air containing water vapor and several torr of CO_2 .

Under these conditions, a rapid and continuous measurement of the concentration of every trace contaminant present might appear to be virtually impossible. Two alternatives present themselves:

- First, one could select a few species which were "representative" of the overall air quality and devise methods to measure them. We believe that this approach is a good first step, but by itself it is not completely adequate. Far too little is known to be able to predict accurately what contaminants will indeed be present 80 days into a mission. The appearance of an unexpected contaminant would go undetected and could either harm the crew or cause a panic abort that might be otherwise eliminated by proper corrective action. The classic example of this case is the abort of the MESA experiment[4], where dichloroacetylene was finally identified as the unexpected toxic contaminant that formed in the control system.
- A second possible solution is to attempt to devise monitors for classes of compounds. At least two previous attempts have been made by others to assign a single MAC to each of a number of logical groupings of contaminants – groupings by chemical functionality (halocarbons, aromatics, ketones, aldehydes, etc.)[6] and grouping by toxic effect (irritant, narcotic, asphyxiant, etc.).[7] These approaches suffer from the difficulty of devising transducers that distinguish between the different groups.

Therefore, we conclude that a complete analysis of contaminants in the atmosphere must be performed, by whatever means are necessary. Each chemical species should be measured individually. The capability for detecting, identifying, and quantifying an unexpected contaminant *must* be included. Coping with the unknown is particularly important, because the mission duration will far exceed the duration of realistic, manned ground simulations.

Fortunately, barring a catastrophic event, the demands on the overall air quality monitoring system are eased to some extent by the fact that trace contaminant buildup is normally slow. Analyses at intervals of 6-12 hours will probably provide adequate warning of the approach of a contaminant to its MAC. This analysis interval might have to be somewhat shorter[8]; a more definite decision awaits additional experiments on contaminant production rates.

B. RAPID MEASUREMENT OF SELECTED SPECIES

As pointed out earlier, rapid measurement of selected species near their sources would help to detect and locate dangerous, rapid buildups of toxic species due to pyrolysis or failure of an experiment. Another reason for more frequent analysis is that some highly toxic contaminants may be near the threshold of detectability of the total atmospheric monitor. By increasing the frequency of measurement, greater confidence might be placed in the contaminant level trends derived from the analytical measurements.

As a point of departure for selecting a group of compounds that should be continuously monitored, Table 1 contains a list of the more toxic species ($MAC < 10 \text{ mg/m}^3$) found in enclosed atmospheres.[1,5] (although somewhat less toxic, CO was included because of its important long-term toxicity.[5] Interestingly, virtually every contaminant that warrants frequent analysis near its source as a performance or hazard indication is included in the list of the most toxic species. It should also be noted that a large number of species on the list are highly reactive and would be difficult to measure in a total-atmosphere monitor which required sampling and separation.

TABLE 1
POTENTIAL CONTAMINANTS OF HIGH TOXICITY*

Contaminant	SMAC (mg/m ³)	Source		
		Oxidation Product	On-Board Experiment	Fire or Overheating
Acetic Acid	2.5			
Acetonitrile	7.0			
Acrolein	0.25			
Allyl Alcohol	0.5			
Ammonia	3.5			
Benzene	8.0			
Carbon Disulfide	6.0			
Carbon Monoxide	29.0	X		X
Carbon Tetrachloride	6.5			
Carbonyl Fluoride	66.0*	X		X
Carbonyl Chloride	99.0*	X		X
Chlorine	1.5	X	X	X
Decalin	5.0			
Dimethyl Furan	3.0			
Dimethyl Hydrazine	0.1		X	
Ethyl Mercaptan	2.5			
Formaldehyde	0.6			
Furan	3.0			
Furfural	2.0			
Hydrogen Chloride	0.15	X	X	X
Hydrogen Fluoride	0.08	X	X	X
Hydrogen Sulfide	1.5			
Methyl Furane	3.0			
Mesitylene	2.5			
Monomethyl Hydrazine	0.035		X	
Methyl Mercaptan	2.0			
Naphthalene	5.0			
Nitrogen Tetroxide	1.8		X	
Nitrogen Dioxide	0.9	X		
Pyruvic Acid	0.9			
Phenol	1.9		X	
Sulfur Dioxide	29.0	X	X	

* From Ref. [5], MAC values (submarine) for 60-min. exposure.
24-hr MAC for carbonyl fluoride not available.
24-hr MAC for carbonyl chloride is 9.9 mg/m³.

Source: Adapted from Ref. [1], Appendix A.

VI. DETECTION TECHNIQUES

For one to reach meaningful conclusions from a survey of trace contaminant detection techniques, the criteria to be used in evaluating the suitability of a technique must first be established. Obviously, for space flight application, reliability, weight, space, and power requirements are of great importance. One must also consider whether or not the technique is basically appropriate for the intended application. Listed below are the fundamental criteria which determine how well a technique meets the requirements for the two types of contaminant monitors.

Intermittent Contaminant Monitor (ICM)	Continuous Contaminant Monitor (CCM)
Adequate sensitivity	Adequate sensitivity
Selectivity	Selectivity
Universal detection	Fast response
Identification of unknown	Remote sensing desirable
Slow response tolerable	Nonuniversal detection
Captured sample permissible	Identification capability not required

Adequate sensitivity is a first consideration in the evaluation of a measurement technique. The technique must be able to measure reliably a given contaminant at a concentration below its MAC. For techniques in which an atmospheric sample is taken, preconcentration by trapping and eliminating most of the air in the sample is a permissible way to increase effective sensitivity.

Selectivity must be adequate to insure that the measurement of a given contaminant is not influenced significantly by the presence of varying amounts of other species in the atmosphere. Requirements for selectivity become especially difficult to meet when the contaminant of interest is at a very low concentration in the presence of higher concentrations of other species.

To cope with the appearance of an unexpected contaminant, the ICM must be able to respond to all possible contaminants. The previously defined role of the ICM would permit a single analysis of overall atmosphere quality to be performed over a relatively long period of time. With the present state of the art in analytical techniques, relaxation of the time constraint is a major requirement if each contaminant is to be selectively measured. Since the purpose of the ICM is to determine total atmospheric quality, a single representative sample of the atmosphere could be taken for subsequent analysis. Sample-taking permits the use of preconcentration techniques to reduce the requirements on instrument sensitivity.

The CCM is, by definition, required to detect previously defined contaminants, so it should respond only to those contaminants. Limiting the CCM response in this way makes the task of selective measurement significantly easier. Its response must be as fast as possible, so that it can provide adequate warning of hazards that develop rapidly. For a number of reasons it is also highly desirable that the CCM be capable of sensing the contaminants remotely. Remote sensing reduces the delay between the first production of contaminant and its arrival at the sensor. In addition, many of the species which should be monitored continuously are highly reactive and corrosive; attempting to sample and preconcentrate such species often leads to significant loss of the contaminant during the sampling step.

The major instrumental analytical techniques will be discussed briefly and evaluated with respect to their suitability as ICM's and/or CCM's. Gas chromatography, mass spectrometry, and infrared spectrometry will be discussed only very briefly, since they are the preferred techniques and are treated in detail in Section VII.

A. GAS CHROMATOGRAPHY

By using ionization detectors and/or sample concentration steps prior to introduction into the column, gas chromatography (GC) can detect extremely small amounts of material. Measurements in the sub-ppm range are routinely achieved. Selectivity can be enhanced by use of a selective detector and/or a high-resolution separating column.

Gas chromatography has only a limited ability to deal with unexpected species. Some information about the nature of an unknown can be obtained by noting the time at which it appears at the exit of the column. Retention time on a single column provides only one piece of information, for example, an approximate boiling point, which is insufficient to identify an unknown molecule.

Because of its relatively long response time, particularly when used with high-resolution columns, GC is best suited for use as an ICM. GC alone is a less-than-ideal ICM, however, because of its inability to cope with an unknown contaminant and its potential lack of complete selectivity in analyzing trace contaminants in a very complex mixture, especially when a universal detector is used.

B. MASS SPECTROMETRY

The mass spectrometer (MS) is a highly sensitive and virtually universal detector. Molecules to be analyzed are ionized by one of a number of types of ionization sources. The initial molecular ion decomposes into a series of fragment

ions whose abundance versus mass is subsequently determined. The fragmentation pattern which is observed usually permits identification of the unknown.

A fundamental limitation of mass spectrometry is its inherent lack of selectivity when analyzing a complex mixture. Because it is a universal detector, a mass spectrum of the complex mixture found in a spacecraft atmosphere would be completely unintelligible. Selectivity can be increased to some extent by first trapping the trace contaminant on a selective absorbent.[9] If the trap is then heated slowly, only a few constituents enter the mass spectrometer concurrently. However, as the number of contaminants to be analyzed increases, it becomes increasingly likely that severe interferences will exist even with such a programmed elution technique.

The ultimate solution to this problem is to precede the MS measurement with a high-resolution GC separation. Extremely complex mixtures can be separated on a high-resolution capillary GC column and presented one (or, at worst, a few) at a time to the MS for identification and quantification. The combined GC/MS technique meets well the fundamental requirements of an ICM.

C. OPTICAL SPECTROMETRY

1. General Principles

Empirical observations and theoretical calculations show that a molecule will behave in a manner specific to its structure when it absorbs a quantum of energy. This principle has led to the development of a series of analytical methods using various parts of the electromagnetic energy range. Table 2 lists the most common techniques and the portion of the electromagnetic spectrum which they use. The energy associated with the particular quantum transitions are also listed. As the energy becomes smaller (as in microwave and nuclear magnetic resonance spectrometry), the experimental requirements for observing the transitions become much more exacting.

While of significance in structure determination and some quantitative measurement areas, nuclear magnetic resonance does not have the proper characteristics (especially sensitivity) to be considered for trace monitoring. The other techniques are discussed below.

2. Ultraviolet-Visible

Absorption in the ultraviolet-visible portion of the spectrum is due to transitions between various molecular electronic energy levels. Superimposed on these broad electronic bands are vibrational and rotational fine structure. Figure 2 is an example of a well resolved spectrum of SO₂.

TABLE 2
ELECTROMAGNETIC ENERGY SPECTRUM

Spectrometric Technique	Wavelength	Frequency (Hz)	Wave Number (cm ⁻¹)	Energy (Kcal)
Ultraviolet	0.2 - 0.4 μm	10 ¹⁵	10 ⁶	100
Visible	0.4 - 0.7 μm	10 ¹⁴	10 ⁵	50
Infrared	2.5 - 40 μm	10 ¹³	10 ² - 10 ³	5
Microwave	0.1 - 20 cm	10 ¹⁰	10	10 ⁻⁴
Nuclear Magnetic Resonance	100 cm	10 ⁸	10 ⁻¹	10 ⁻⁷

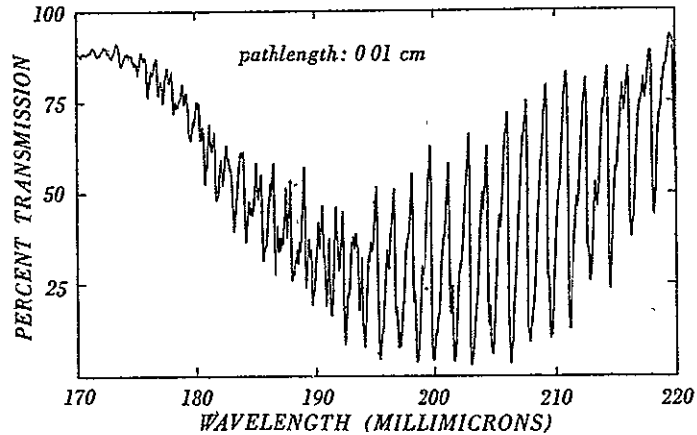

FIGURE 2 ULTRAVIOLET SPECTRUM OF SULFUR DIOXIDE

Specific measurements of the concentration of contaminants in this region of the energy spectrum would be difficult because of the broad-band nature of the electronic transition. Some measurements would be possible using the vibrational-rotational fine structure, and these are discussed in greater detail in Section VII-B.

While some species, such as SO_2 , NO_2 , Cl_2 , Br_2 , and some of the aromatic contaminants, have transitions between 220 and 700 nm, many of the species of interest such as HF, HCl, butanol, methane, and CO have transitions at shorter wavelengths. Unfortunately, the region below 220 nm is cut off from use, because oxygen begins to absorb at that point. This atmospheric cut-off minimizes the possibilities of utilizing the ultraviolet-visible region for either trace contaminant monitoring task.

3. Infrared

Infrared spectrometry measures the absorption of energy associated with molecular vibration-rotational transitions. All species (except for symmetrical ones such as H_2 and Cl_2 , which undergo a dipole moment change during vibration) have infrared absorption spectra. A typical infrared spectrum — in this case, of methane — is shown in Figure 3. The position (cm^{-1} or μm) of absorption in the infrared depends upon the change in dipole moment during the vibrational transition. Because many structural elements such as C-H, -OH, =CO, - NO_2 , and C-Cl normally absorb in a particular region, infrared spectra are very useful in qualitative analysis.

It would be difficult to utilize infrared spectrometry for the ICM, since it has a limited ability for absolute analysis of unknowns; such an analysis normally requires a reference spectrum for comparison. The task would be particularly difficult in the complex mixture of spacecraft contaminants, since many of the bands which could serve to differentiate isomers or members of a homologous series might be obscured by bands from other molecules.

Infrared spectrometry does appear to be especially promising for the CCM task. Most of the species which it seems reasonable to monitor on a continuous basis are small, and their rotational-vibrational transitions are easy to resolve on existing spectrometers. Utilizing the rotational fine structure, it is, for instance, a simple matter to measure methane in the presence of ethane. The specific measurement of trace quantities can be carried out more reliably with correlation techniques. A detailed description of these techniques and our recommendations for criteria to be determined to evaluate its full potential as a CCM are given in Section VII-B.

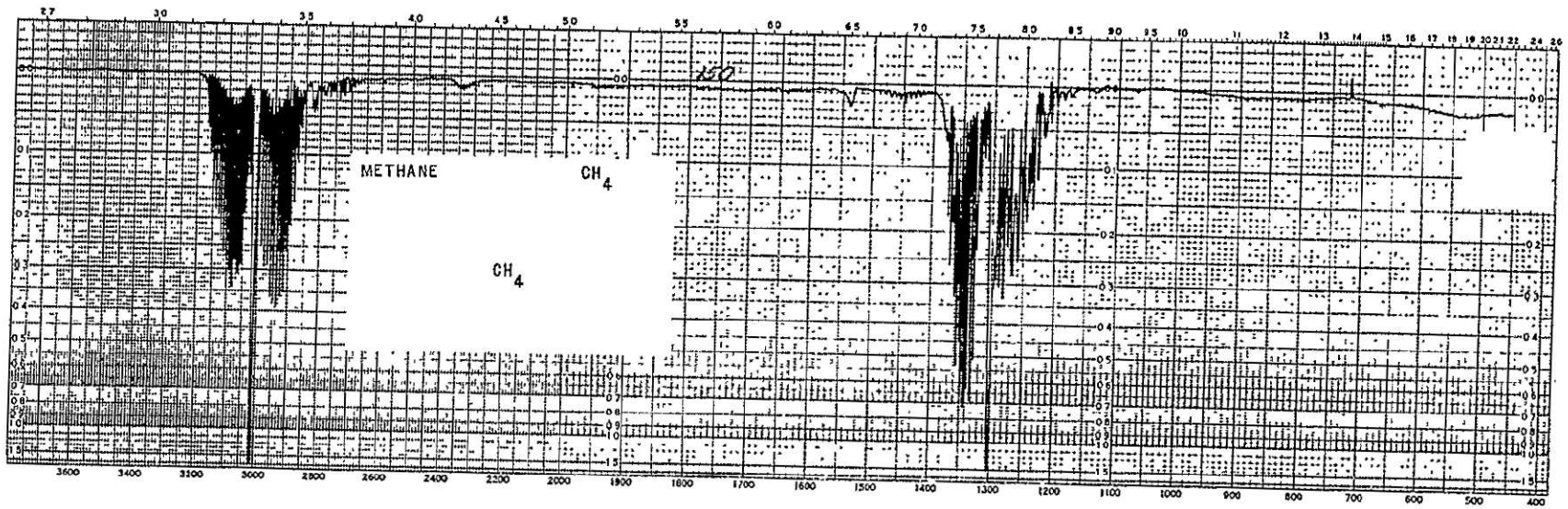

FIGURE 3 INFRARED SPECTRUM OF METHANE

4. Microwave

Microwave spectrometry has high potential for trace contaminant analysis. The spectral absorption bands arise from the absorption of energy due to transition from one molecular rotational energy level to another. The technique therefore studies properties that are characteristic of the entire molecular structure rather than of functional groups as in infrared spectrometry.

Microwave spectrometry has just begun to be developed as a tool for the analytical chemist. Although it has been used by the physicist, spectroscopist, and physical chemist for studies on molecular bond angles, bond distances, and dipole moments, available instrumentation was too complex for routine use. Recent developments in research instrumentation have encouraged more practical application of the method.[10, 11]

For a measurement to be possible, the molecule must have a dipole moment, be in the gas phase, and be at reduced pressure (1-100 microns) to permit optimum rotation and energy transfer. Also, because the absolute amount of energy absorbed during a rotational transition is very small, normal approaches to absorption spectrometry cannot be utilized. Therefore, one has to employ a modulation technique which permits distinguishing a small signal in the presence of large ones. The most frequently used modulation technique is the Stark effect, whereby a d-c field alternating between a few and 4000 volts/cm is applied to the sample. This field is applied at a rate generally between 5 and 100 kHz, so that any molecule with a dipole moment will find itself alternately in a field/no-field situation. At the resonance frequency for a rotational transition, the difference in the signal between the two situations is detected, amplified, and recorded as an absorption line.

Although a dipole moment is required, the polarity of the compound need not be large. For example, propane (whose dipole moment is 0.01 Debye units) exhibits strong microwave resonance lines.

Another possible constraint is that the molecules cannot be "too large." As the molecule becomes larger, the number of rotational energy levels increases; because the total energy available is fixed by the temperature (kT), the number of molecules in any one rotational state decreases, and the signal intensity is diminished. Currently, a rough index of "usable" molecular size is up to C_{12} . As instrumentation improves, this will undoubtedly be extended to larger molecules. At the present time, small polar molecules such as NH_3 , SO_2 , and $HCHO$ can be detected at concentrations of fractions of a part per million. Sensitivity generally varies inversely with size and directly with dipole moment.

The major attractiveness of microwave spectrometry arises from its very high resolution capability. In the 10-20 micron pressure range, absorption bandwidth ranges from 0.1 to 0.5 mHz. Since current instrumentation provides a microwave range of 8 – 40 GHz with an instrumental resolution of less than 0.1 mHz, between 60,000 and 100,000 resolution elements are available for information storage and utilization. Thus, even though a single molecule may have hundreds of lines, the chances for complete overlap, even in a complex mixture, are remote. Therefore, positive identification for qualitative purposes can be made on the original unseparated sample using only a few high-resolution frequency measurements. If desired, quantitative analysis can easily be made using a single line, and the precision and accuracy will be equal to that obtainable by other instrumental techniques.

The microwave spectrometer is probably most immediately applicable to continuous contaminant monitoring (CCM). Many of the compounds selected for continuous monitoring, including NH_3 , COF_2 , COCl_2 , HCl , and HF , have small, polar molecules and are thus ideally suited to this form of analysis. Given the development of suitable instrumentation for single-component monitoring, the high resolution capability of this technique makes it very attractive for reliable and accurate monitoring of a specific compound in a complex mixture. Unfortunately, no such instruments are available currently, so the demonstration of this presumed capability will have to wait. We believe that a number of groups are working on the development of such instruments, so the picture should change within a few years.

The high resolution obtainable with microwave spectrometry suggests that it would make an ideal technique for total contaminant analysis in the ICM. This characteristic, coupled with the fact that the molecular absorption lines are highly specific, would make the presence of a new and unexpected molecule easy to detect. Unfortunately, only about 50 molecules have been catalogued sufficiently well to be useful in the identification of unknowns. Therefore, a great deal of effort is needed in developing microwave spectral data for hundreds of additional compounds before the technique could be seriously considered for the ICM.

5. Raman

The recent development of reliable laser light sources has made it possible to put Raman spectroscopy on the same basis as infrared spectroscopy in the laboratory.

Raman spectroscopy is based upon the quantitative changes in frequency which occur when light is scattered by molecules. Most light is scattered by a molecular system with the same energy as the incident photons (Rayleigh scattering). However, when using a monochromatic light source, one can observe a

gain or loss in energy of a small portion of the photons. This difference is known as Raman scattering, and the increase and decrease in light energy is referred to as anti-Stokes and Stokes lines, respectively.

The light sources normally used are in the visible region, and the frequency shift corresponds to the same energies as the infrared region. The Raman spectra are normally recorded as frequency shifts, Δcm^{-1} . The selection rules are different for Raman spectroscopy than for infrared: a change in dipole moment is required for infrared activity, but for Raman activity there must be a change in the induced dipole resulting from a change in polarizability of the molecule.

The advantages of Raman spectroscopy are that conventional optics may be used and that water vapor has a very weak Raman spectrum. On the other hand, it uses only a small amount of the scattered light, and interference from extraneous light is more serious than in infrared spectroscopy, where a higher level of energy is measured; however, these disadvantages have been largely overcome by the use of laser light sources. Raman spectra are generally much simpler than infrared spectra, so the problem of interferences would be minimized.

The basic limitation with Raman spectroscopy at the present time is that its full analytical value has not been shown. While the spectra of some gases have been observed at the ppm level, the detection sensitivity varies with the molecular species. Many of those that satisfy the Raman selection rules have very low absorptivity. Reference spectra are now available for only a few species, but a considerable number should be available in 1–3 years.

Development of instrumentation is just at the stage where large research models have been scaled down to bench-top instrument size. It will probably be some time before all of the required information is available to assess the potential of Raman spectrometry for trace contaminant analysis and for the development of flight-qualified hardware.

6. Emission

Emission spectrometry is discussed briefly here because of its potential if future requirements for trace contaminant monitoring differ from those now assumed.

Emission spectrometry involves raising dissociated atoms (or sometimes groups of atoms) to an electronically excited state and then observing their emission spectrum. Flames, arcs, and sparks have all been used as excitation sources.[12] The line spectra obtained are quite specific for the element: the spectra of sodium (sodium D line) and mercury (lamps) are classic examples.

More recently, Cooke[13] and West[14] have used radio-frequency (30 MHz) and microwave (2450 MHz) plasmas on the effluent from a gas chromatograph and have been able to detect from 0.1-100 parts per billion of elements in the gas phase. This suggests the possibility of direct detection of F, Cl, S, N, C, etc. at the ppb level in the spacecraft atmosphere. The detection would, of course, be nonspecific; all fluorine-containing species, for instance (such as both HF and Freon 113) would give a positive signal.

Since some species will always be present in the cabin atmosphere, the trace contaminant monitor must be highly specific; however, should it be possible to achieve a state where all contaminants would be held below some set level and a rise above that level of any contaminant would constitute an alert, then an emission spectrometer could function as a very sensitive total contaminant monitor of low specificity.

The potential of this approach should be considered when the control of contaminants reaches an appropriate stage.

D. ELECTROCHEMICAL DETECTORS

Methods based on electrochemical measurements are widely used for terrestrial monitoring of air pollutants, particularly the oxides of sulfur and nitrogen. Since they are small, lightweight, and require very little power, they are potentially attractive as CCM's. The three primary techniques for making electrochemical measurements of pollutants are described below.

1. Conductometry

Conductometric analyses involve the absorption of a gaseous species into an appropriate solvent/reactant mixture. If the compound of interest dissociates to form ions in solution, the conductivity of the solution changes; this change can be measured and related to the concentration of the species sought. The method is inherently nonspecific, since any soluble gas that forms a strong electrolyte in the particular solution used will cause a change in conductivity. Interfering species are either scrubbed out chemically before the gas reaches the conductivity cell, or the solvent in the cell is chosen so that interfering species do not dissociate.

Conductivity measurements are used to determine SO_2 in ambient air at levels as low as 0.1 ppm. The procedure of measurement involves passing the sample gas through a very dilute solution of H_2SO_4 containing about 3% H_2O_2 . The SO_2 dissolves to form sulfuric acid, which increases the conductivity of the solution. Fresh solvent must be put into the cell prior to each analysis. Because of the difficulties in handling liquids in the absence of gravity, a conductometric measurement would be most unwieldy.

2. Potentiometry

Potentiometry involves the measurement of the EMF of a galvanic cell at essentially zero current flow. The gas or liquid sample is placed on one side of an outer, nonspecific membrane. The contaminant of interest passes through the membrane and creates a concentration of related ions in the anode or cathode chamber. A standard solution containing a known amount of the same ion is contained in another chamber, which forms the opposite pole of the cell. The difference in the activities of the ions in the two chambers causes an EMF to be developed which is measured and related to concentrations. If the membrane separating the chambers is sensitized so that only a single ionic species can permeate it, the EMF developed is related only to the concentration of that species. This principle is the basis for the ion-selective electrodes now widely available for measuring various ions in solutions. [15]

A specific ion electrode might be suitable for measuring a given species such as HCl or HBr. But as in the case of conductometric measurement, the gas would have to be passed through a liquid in which the species of interest dissolved to produce the ions that are subsequently detected. The requirements for storage and manipulation of solvent liquids make this approach undesirable.

3. High-Temperature Concentration Cell

Since ionic species are involved in electrochemical measurements, the presence of a liquid is required to permit ionic transport at low temperatures. However, at elevated temperatures ionic conduction can occur in solids. Oxide ion transport through zirconia heated to a temperature of at least 500°C is the basis of an oxygen monitor capable of measuring oxygen partial pressures ranging from 1 to 10^{-3} atmospheres. [16] The cell is similar to the potentiometric electrode: a difference in oxygen concentration between the reference side and the unknown side of the electrode generates an EMF across the zirconia, which is permeable to oxide ions. Platinum electrodes deposited on both sides of the zirconia are attached to a potentiometer, and the resulting EMF can be related to the difference in oxygen concentration.

Development of the high-temperature concentration cell detector has been quite recent. It might be possible to use a different material, perhaps a chloride, as the active ingredient in such a cell to permit the monitoring of chlorine, for example. Nevertheless, the requirement that the cell be heated to a very high temperature would make such a technique undesirable from the standpoint of power requirements.

4. Polarographic Sensors

Electrochemical transducers based on polarography have recently become commercially available.[17] The gaseous species to be measured diffuses through a membrane and a thin layer of electrolyte to reach a sensing electrode, where charge transfer takes place. The electrode reaction results in a current flow which is proportional to the partial pressure of the gas being measured.

The electrode does not require the presence of a liquid outside the outer membrane; the gaseous species to be monitored travels directly from the gas phase through the membrane into the electrolyte. Versions of this electrode are available which will reportedly monitor either SO_2 , NO_2 , or NO_x at a low-ppm level with high specificity. Response time to reach 90% of a final steady state reading ranges from 10 to 35 seconds.

A device of this type has potential applications as a CCM — particularly in the catalytic oxidizer, where the presence of SO_2 and NO_2 are of particular importance; but one of the major problems with devices of this type is that, like most electrochemical transducers, they require frequent maintenance and/or replacement.

5. Conclusions

In spite of some interesting future possibilities, it does not appear appropriate at this time to consider using electrochemical sensors for trace contaminant monitoring, even as part of the CCM. The space environment/maintenance characteristics pose special burdens on solution approaches, the present devices are not sufficiently specific, and the present state of the art in solid-state methods precludes development of suitable sensors in the immediate future.

VII. DETAILED CONSIDERATION OF RECOMMENDED TECHNIQUES

We concluded earlier that trace contaminant monitoring (TCM) requires both intermittent (ICM) and continuous (CCM) monitors with different tasks and requirements; our review of instrumentation available to accomplish this task in the spacecraft environment (Section VI) led to the choice of combined gas chromatography-mass spectrometry and infrared spectrometry (particularly with correlation) to satisfy the respective requirements. Although we have not yet been able to reach sufficiently definite conclusions to permit the description of a specific choice of hardware for the chosen analytical methods, we have explored in some detail those portions of the instrumentation which are most important to consider. A detailed discussion of these aspects is given in this section.

A. GAS CHROMATOGRAPHY-MASS SPECTROMETRY (GCMS)

The intermittent contaminant monitor (ICM) must measure the quality of the spacecraft atmosphere and be able to recognize more than 200 known compounds. Furthermore, until extensive ground tests and analyses have been carried out, it must also be able to detect the presence of new or unexpected species.

The only known technique which will satisfy the need of the unexpected event is a combination of gas chromatography (GC) and mass spectrometry (MS). GCMS techniques were recently reviewed by Updegrave and Haug.[18] The latter particularly emphasized the advantages obtained in designing an integral analytical instrument that makes optimum use of the combined gas chromatograph-mass spectrometer. Reliable laboratory instrumentation has recently been developed to take maximum advantage of the combination, namely, the series of GCMS computer-controlled instruments introduced by Finnigan Instruments Corporation.[19]

The basic configuration of an optimized GCMS system is shown in Figure 4. The order of emphasis in a combined system is to rely on the GC primarily for separation of the mixture and to depend on the MS for identification of the resolved components.

Because the GC sampling and sample introduction mode into the MS allows the sample to be concentrated in time, the overall detection sensitivity of a combined system is greater than that of an MS alone.

Each of the basic components of a GCMS system is discussed below.

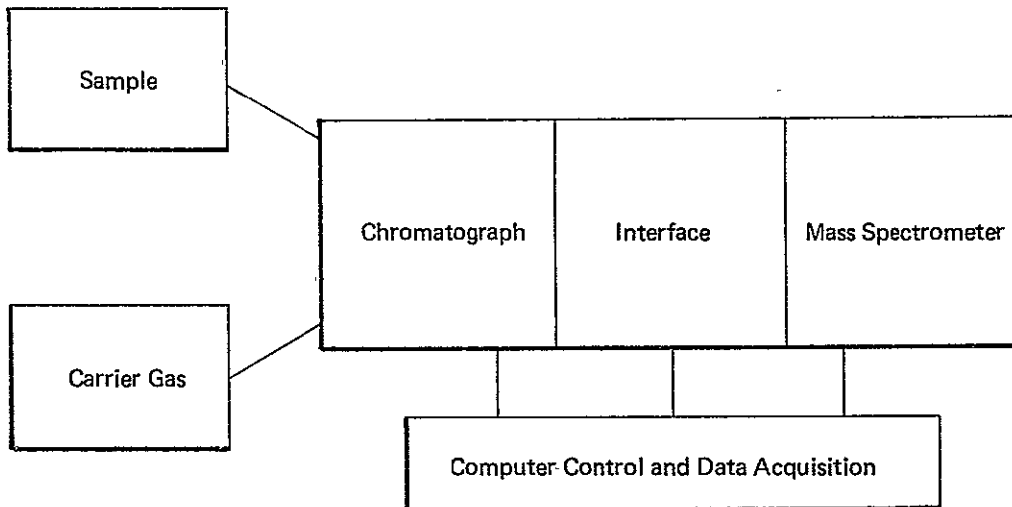

FIGURE 4 SCHEMATIC REPRESENTATION OF A GAS CHROMATOGRAPH – MASS SPECTROMETRY SYSTEM

1. Gas Chromatography (GC)

The two primary components of the GC are the sample introduction system and the chromatographic column on which the separation is performed. In addition, a carrier gas supply system provides a gas flow to sweep the injected sample over the chromatographic column. Programmed elution devices for increasing the column temperature and/or carrier gas flow rate as the analysis proceeds are useful in reducing the analysis time for mixtures of widely differing species. The MS is, of course, the primary detector for species emerging from the column. One or more conventional GC detectors may be operated in series or parallel with the MS to provide additional information and reliability through redundancy.

Although the GC is a simple and sturdy device, a number of parameters affect its performance and may be varied to optimize the separation of a given mixture. As a result, there is no single, best set of operating conditions to effect the separation of even a simple, well-defined mixture. For a task as complex as the complete analysis of a dynamically changing background of trace contaminants in a spacecraft atmosphere, optimization is even more difficult.

Nevertheless, the basic requirement remains quite clear: the GC should have maximum capability for a high-resolution separation of a wide variety of species. In the paragraphs that follow, we shall evaluate the basic GC components in an attempt to arrive at a baseline configuration which can be subjected to further experimental modification.

a. Chromatographic Column

The two primary considerations in choosing the type of chromatographic column are the nature of the stationary material and its method of deployment in the column. The former governs the order in which a series of compounds will elute from the column, while the latter is the major contributor to column efficiency.

A further important consideration is the reactivity of the active species (HF, SO₂, etc.) with the stationary phase. For this reason the roles of the ICM and CCM become interdependent for a total atmosphere analysis.

(1) Nature of the Stationary Phase. Stationary phases may be broadly divided in two classes — selective and nonselective. Selective stationary phases show a high affinity for compounds with a particular characteristic such as polarity or unsaturation. Nonselective phases generally produce a separation that corresponds with boiling point: lower boiling species elute before those with higher boiling points.

For the separation of a wide range of compounds such as may be encountered in a spacecraft atmosphere, the use of a nonselective stationary phase is to be recommended. While excellent separations of closely boiling alcohols, for example, can be achieved with a polar, selective phase, the overall separation of a wide range of differing compounds on the same column is difficult to predict and is usually less than ideal. Table 3 lists the boiling points and MAC values of compounds reported in enclosed atmospheres; these data allow one to evaluate the GC column performance required to achieve a separation of the species.

The use of a nonselective phase offers the additional advantage in that when an unknown species appears in the chromatograph output, its boiling point can be estimated from its elution time. This information could be useful in resolving an ambiguity in the MS identification of the species.

A second important consideration with respect to choice of stationary phase is its thermal stability. The decomposition of the phase should be held to a minimum to avoid the generation of detectable volatile products. This phenomenon, commonly termed "column bleed," interferes with the mass spectra of the sample peaks being eluted and contributes to contamination of the ionization

TABLE 3
BOILING POINTS AND MAC'S OF CONTAMINANTS
OBSERVED IN SPACECRAFT ATMOSPHERES

Compound	Boiling Point (°C)	Maximum Allowable Concentration (mg/m ³)
Hydrogen	-252	215
Carbon Monoxide	-171	29
Methane	-161.6	1720
Nitric Oxide	-150	32
Ethylene	-102.5	180
Nitrous Oxide	- 89.8	47
Ethane	- 88.6	180
Acetylene	- 83.6	180
Freon 23	- 82.2	12
Tetrafluoroethylene	- 78.4	205
Hydrogen Sulfide	- 60.2	1.5
Carbonyl Sulfide	- 50	25
Propylene	- 47.8	180
Propane	- 44.5	180
Freon 22	- 40.8	350
Chlorine	- 34.5	1.5
Ammonia	- 33.5	3.5
Cyclopropane	- 33	100
Freon 12	- 29.8	500
Methyl Chloride	- 23.7	21
Methyl Acetylene	- 23.1	165
Formaldehyde	- 21	0.6
Vinyl Chloride	- 13.9	130
Isobutane	- 11.7	180
Sulfur Dioxide	- 10	0.8
Chlorofluoromethane	- 9.1	24
Isobutylene	- 6.9	180
Butene-1	- 6.3	180
1,3-Butadiene	- 4.4	220
n-Butane	- 0.5	180
Methyl Acetate	56.3	61
1, 1-Dichloroethane	57.3	40
Chloroform	61.1	24
Dimethyl Hydrazine	63	0.1
3-Methyl Pentane	63.3	295
Hexene-1	63.5	180
Methyl Furan	64	3
Tetrahydrofuran	64	59
Methyl Alcohol	64.5	26
Isopropyl Ether	67.5	120
n-Hexane	68.7	180
Butyraldehyde	74.8	70

TABLE 3 (Continued)

Compound	Boiling Point (°C)	Maximum Allowable Concentration (mg/m ³)
Methyl Chloroform	75	190
Carbon Tetrachloride	76.7	6.5
Ethyl Acetate	77.1	140
Ethyl Alcohol	78.3	190
Methyl Ethyl Ketone	79.6	59
Propyl Mercaptan	65-80	82
Benzene	80.1	8
Cyclohexane	80.7	100
Acetonitrile	81.6	7
tert-Butyl Alcohol	82.3	30
Isopropyl Alcohol	82.4	98
Cyclohexene	82.6	100
Ethylene Dichloride	83.5	40
Trichloroethylene	87.2	52
Monomethyl Hydrazine	87.5	0.035
Ethyl Sulfide	92	97
Ethyl Butyl Ether	92.2	200
Methyl Isopropyl Ketone	93	70
Dimethyl Furan	94	3.0
Aliyl Alcohol	97	0.5
n-Propyl Alcohol	97.1	75
Heptane	98.4	200
Isobutyl Alcohol	99.5	30
Methyl Cyclohexane	100.9	200
Methyl Methacrylate	101	41
1,4-Dioxane	101.3	36
n-Propyl Acetate	101.5	84
Methyl Butyrate	102	30
Valeraldehyde	102	70
Propylene Aldehyde	104	10
Toluene	110.6	75
Methyl Isobutyl Ketone	115.8	41
Acetic Acid	117.7	2.5
n-Butyl Alcohol	117.7	30
Chloroacetone	119	100
1,1-Dimethyl Cyclohexane	119.2	120
Tetrachloroethylene	121.2	67
trans-1, 2-Dimethyl Cyclohexane	122.8	120
Octane	125.6	235
Butyl Acetate	126.1	71
Chlorobenzene	131.7	35
Ethyl Benzene	136.2	44
Amyl Alcohol	137.3	36
p-Xylene	138.3	44

TABLE 3 (Continued)

Compound	Boiling Point (°C)	Maximum Allowable Concentration (mg/m ³)
m-Xylene	139.1	44
Cyanamide	140	45
Propionic Acid	140.8	15
o-Xylene	144.4	44
Styrene	145.2	42
Amyl Acetate	149.2	53
Cumene	152	25
n-Propyl Benzene	159.2	44
Cyclohexanol	161.1	20
Furfural	161.7	2
Butyric Acid	163.2	14
Mesitylene	164.6	2.5
Diisobutyl Ketone	168.1	29
1,2,4-Trimethyl Benzene	168.9	49
Phenol	181.7	1.9
trans-Decalin	185.5	5.0
Valeric Acid	186.3	110
cis-Decalin	195	5.0
Ethylene Glycol	197.2	114
Naphthalene	210.8	5.0
Caprylic Acid	239.3	155
Indole	254	126
Skatole	265	141

source of the MS. Over extended periods of time, column bleed results in a degradation of column performance.

On the basis of the criteria of nonselectivity and thermal stability, the silicones SF-96 and SE-30 are the stationary phases of choice. For the Viking Project GCMS, SF-96 was found to be useful over the temperature range of -50 to 220°C.[20] Columns using SE-30 have an even higher upper temperature limit, but the liquid solidifies and is unusable near ambient temperature. A new phase, OV-1, is reported to be even more stable than SE-30.[21]

Two other approaches to a stable stationary phase deserve mention. The "brush" columns of Halasz[22] consist of particles of silica chemically bonded to an organic stationary phase. The bonding process involves an esterification to the Si-OH groups on the solid, however, and in the presence of even traces of water, the bond is hydrolyzed at elevated temperatures, leading to column bleed. The porous polymer bead packings (e.g., Porapak), which have recently received a great deal of attention, have been found to be stable thermally. However, they are primarily valuable for separating materials with low molecular weights [23]; thus, they are not suitable for a single column in the GCMS.

(2) *Stationary Phase Support and Type of Column.* The diameter of the column used and the manner in which the stationary phase is dispersed within the column are important in determining column efficiency. A commonly used measure of column efficiency is the height (H) equivalent to a theoretical plate, which is equal to L/N, where L is the column length and

$$N = 16 \left(\frac{x}{y} \right)^2$$

where x = component retention distance. y = width of the eluting component at the base of the peak.

Since a highly efficient column should produce a narrow peak at even long retention times, one seeks to minimize H in an efficient column. Alternatively, N, the number of theoretical plates (N=L/H) in a given column is maximized.

Best separating efficiencies are obtained with narrow-bore (0.01-0.02 in. ID) columns. The well-known Golay column is simply a long capillary tube containing a thin film of stationary phase on its inner surface. A column of this type is employed in the Viking GCMS; it is 200 feet long and has 50,000 theoretical plates.[20] The high efficiency of the Golay column has been widely utilized in separations of complex mixtures. For example, over 240 components of gasoline were separated in a single run[24]; the individual hydrocarbons had boiling points ranging from -42°C to 216°C.

The extremely thin film of stationary phase on the Golay column limits the amount of sample that can be separated. To accommodate larger samples, more stationary liquid phase must be used, but thick films are deleterious to separating efficiency. Larger amounts of liquid phase are accommodated by dispersing the liquid phase on a finely divided, inert solid support, as in the support-coated open tubular (SCOT) column. The SCOT column is difficult to prepare, and tests by JPL[20] did not indicate a significant capacity difference between it and the Golay column. It would appear that development and test of a Golay capillary and a packed capillary column would offer the most promise for meeting the needs of the proposed GCMS system.

b. Sampling and Sample Introduction

The design of the sample introduction system is of vital importance in maintaining high overall chromatographic efficiency. If the sample is not injected as a sharp, narrow slug, efficiency will be markedly degraded.[25] An atmospheric sample of 1-10 ml will be required to meet the sensitivity requirements of the MS. At a typical capillary column flow rate of about 2ml/min, the peak for a weakly retained species would be up to 5 min wide due to injection broadening alone. Clearly, a trapping step is required to reduce the sample volume prior to injection. By passing them through a cooled, low-volume trap, one can concentrate even low-boiling gases for subsequent introduction into capillary chromatographic columns.[26,27] An alternative is to cool the first few inches of the capillary column itself.[28] The air passes through the cold zone and continues down the column. The trace gases are concentrated in a sharp band at the head of the column and begin to migrate as a sharp band when that zone is quickly warmed.

The use of a subambient temperature trapping technique for concentrating the sample prior to chromatography should receive detailed attention. A cursory evaluation at JPL[20] indicated that about 10-20W would be required to thermoelectrically cool to -70°C a trap weighing a few grams.

c. Carrier Gas and Supply System

The carrier gas is usually hydrogen or helium. Both can be obtained in very high purity. Because of its inert character, helium should be the gas of choice, but certain GCMS configurations will demand another gas. The JPL palladium transmodulator[29] requires the use of hydrogen. The potentially important chemical ionization sources for MS (see VII.3.a) can operate with methane as the GC carrier gas.

The carrier gas will be stored in a high-pressure cylinder. A titanium sphere capable of storing about 250 SCF of helium at 6000 psi was developed for the NASA/MSC chromatograph [30]; at a typical capillary column flow rate of 2 ml/min, this volume of carrier gas would permit 6000 hours of GCMS operation.

d. Programmed Elution

When a complex mixture of compounds having widely differing boiling points is chromatographed at a fixed column temperature, the peaks which appear first are quite sharp, but those eluting later become progressively wider. By systematically increasing the temperature either stepwise or continuously, one can minimize peak width increases during the analysis.

Temperature programming has two important benefits in the proposed GCMS. First, it decreases the analysis time. Second, and more important, it permits greater overall detection sensitivity. The sensitivity of the MS can be rated in terms of g/sec; the less diffuse the peak, the smaller the total amount of material the MS can detect.

The JPL Viking GCMS[20] employs a temperature-programmed column. This temperature, initially maintained at 50°C, is programmed to rise 7.5°C/min to 180°C. While only 2-3 watts are required for the 50°C isothermal hold, the heating requires 20-30 watts. In spite of this power requirement, programmed heating is a requirement for total contaminant analysis by GCMS because of the widely diverse range of chemical species.

e. Detector

Obviously, the MS is the prime detector in a GCMS system. There is some merit, however, in retaining an auxiliary detector in the system. The cross-section ionization detector, which is extremely rugged and quite sensitive, was the detector of choice in both chromatographs designed for space application.[20,30] Inclusion of a cross-section ionization detector between the GC and MS could provide valuable information for dynamically checking the MS performance. In the event of MS failure, the auxiliary detector could supply at least some information with regard to atmosphere quality.

2. GCMS Interface

The early research in coupling the output from a GC to a MS basically worked with instruments designed to be operated independently; various means were developed for joining the two instruments.

The ideal interface would be one in which the GC output went directly and entirely to the MS. However, the basic problem in coupling the instruments is that the GC column exit is normally about 1 atm, while the MS ion source pressure is about 10^{-5} torr. Thus a pressure differential of about 10^6 is required. It is impractical to accomplish this through a high pumping speed in the MS itself; furthermore, such an approach would seriously decrease the system sensitivity, since most of the sample would be lost along with the carrier gas.

The interface chosen for a particular application depends somewhat on GC carrier gas flow rate and sample quantity. The following basic interface types have been developed:

- splitters
- carrier gas diffusion
- carrier gas solubility
- sample solubility

The stream splitter, which directs only a portion of the GC effluent to the MS, is one of the simplest interface approaches. However, the method suffers from the main disadvantage of low sensitivity.

Several interface devices have been constructed which utilize the fact that helium has a higher diffusivity than the sample. These devices usually allow the GC effluent to pass through a region which contains a section of porous material. One of the first of these was built by Watson and Biemann[31] using a porous glass tube. This basic enricher has since been improved to minimize its volume and contamination potential, and a miniature version was recently described by Markey.[32] The enrichment and throughput characteristics of these enrichers are generally good, but they require careful pressure control, they are fragile, and they introduce contamination problems.

A variation of the porous glass enricher are the devices constructed by Krueger and McClosky,[33] Bendix,[34] and General Electric.[35] The Krueger and McClosky device is a straight analog of the Watson-Biemann glass enricher but is constructed of stainless steel, which can be treated to minimize reactivity problems. The devices constructed by Bendix and General Electric use porous silver discs and suffer from the general disadvantage of chemical reactivity. The primary advantage of all of these devices is their mechanical ruggedness.

An interesting jet separator, developed by Ryhage and LKB,[36] causes the GC effluent to flow through a small jet toward an orifice. Both single- and double-stage versions of these separators have achieved high enrichment and throughput factors. In addition, surface catalytic effects and dead volume are minimized. These separators have been used more consistently to solve the

difficult GCMS analyses than any other type of interface. Although its design is critical and it cannot handle a wide range of applications, it probably offers the greatest advantage for optimizing a GCMS system package for a specific analytical task and instrument configuration.

Another helium carrier gas diffusion device is the separator developed by Lipsky, Horvath, and McMurray.[37] This enricher utilizes the fact that helium has an appreciable diffusion rate through Teflon and that this rate varies with temperature. The device consists simply of a short coil of 1/16 in. OD Teflon tubing and has a low dead volume. As the practical problems of fabricating separators of this type without leaks are overcome, it could offer particular advantages in low reactivity.

Several other interfaces based on solubility phenomena have been developed. The palladium transducer[29] developed at the Jet Propulsion Laboratory removes hydrogen carrier gas by diffusion (reactive) through a palladium/silver alloy tube. While there are some advantages associated with its size and efficiency, the catalytic effect of palladium is an obvious disadvantage. An alternative approach, developed by Llewellyn and Littlejohn,[38] uses a silicone membrane to dissolve and transfer the sample to the MS on the basis of a partial pressure difference driving force, while rejecting the insoluble helium carrier gas. The device is unique in providing perhaps the lowest MS operating pressure while maintaining the GC exit at normal pressure. The behavior of the interface depends on its temperature and the type of sample. Its disadvantages are principally in sample discrimination and somewhat in its dead volume.

Final selection of the preferred interface depends to a large extent on the total GCMS system design. Factors such as GC resolution and MS ion source operating pressures will affect the potential selection. A jet separator specifically engineered for a particular system seems to offer the greatest advantage.

3. Mass Spectrometer

The basic requirements for mass analysis depend on the sample characteristics. We have reviewed the expected contaminants in the Baseline ETC/LSS to ascertain the upper limits for mass analysis; Table 4 lists the higher molecular weight contaminants, their molecular weights, and some prominent fragment ions. In some cases, as for carbon tetrachloride and chloroform, the molecular ion is very weak, and the compound is characterized primarily by examination of its fragmentation pattern.

TABLE 4

**MASS SPECTROMETRY CHARACTERISTICS OF HIGH-
MOLECULAR-WEIGHT CONTAMINANTS**

	MW	Major Fragment Peak(s)
Carbon Tetrachloride	152	117/119 (isotope pattern)
Chloroform	118	83/85 (isotope pattern)
Chlorobenzene	112	77, 51
Caprylic Acid	144	129, 127
Decalin	138	96, 67
Freon 113	186	151, 116
Freon 114	168	133, 98
Indole	117	90, 89
Naphthalene	128	127, 64
Silicone (hexamethyltrisiloxane)	222	207, 147, 73
Skatole	131	130, 77
Tetrachloroethylene	164	129, 47
Trichloroethylene	130	95

From the data in Table 4, one can see that an upper mass range of about MW 200 (m/e 200) would suffice for all of the presently identified contaminants. Since hydrogen will be monitored continuously by the CCM, a lower mass limit of m/e 12 is set by the organic compounds. Therefore, a usable mass range for the known contaminants would be m/e 12-200. Actually, we expect that as the analyses are done "on-line" in an actual spacecraft atmosphere and after components have been outgassing for longer periods of time, contaminants of higher molecular weight will be observed at trace levels. A practical upper limit will be set by the vapor pressure of the contaminants. We believe that a desirable mass range would be m/e 12-300. One may refine the requirements as test data (such as from the upcoming McDonnell-Douglas 90-day chamber test) are made available.

The mass spectrometer portion of the GCMS system comprises an ion source, an analyzer, and a detector. Many combinations of the various types of each component have successfully been assembled into research and commercial mass spectrometers. Some of the more appropriate choices for this particular contaminant analysis task are discussed in the following paragraphs.

a. Ion Source

The ion source used almost universally in (organic) structure analysis mass spectroscopy is the electron bombardment source patterned after the Nier type.[39] The key element in this source design is a heated cathode which emits electrons used in ionizing and fragmenting the molecular species for subsequent

ion analysis. Emission current is normally controlled by the filament temperature, while the electron energy is determined by the filament potential. Tungsten filaments are frequently used for the emission source, but they require care in conditioning, since it is the detailed tungsten carbide composition of the filament which determines its emission characteristics. The lifetime of a filament is determined primarily by its vaporization rate and has been quite variable in the laboratory. Bailey and Narcisi[40] have incorporated a 0.003-inch circular tungsten filament in their upper atmosphere spectrometers which has lasted up to 15 months (end of mission) in satellite orbit.

Rhenium has frequently been used for the filament, because its higher operating temperature minimizes conditioning problems. However, the higher temperature also increases the evaporation rate and decreases the lifetime. It is uncertain whether a rhenium filament would last for six months. Thoriated filaments have been used for lower operating temperatures and increased lifetime, but the contamination problems encountered with these filaments make them undesirable for this application.

The Nier source is the only design for which sufficient information is known to include in a GCMS system in the near future. Large libraries of reference spectra, all obtained with electron bombardment sources, are available for the identification of unknowns.

Two other means of ion formation are presently being developed which might be appropriate to consider at a later date when more is known about them. These are the field ionization and the chemical ionization sources.

The field ionization source forms ions by passing the molecules through a region of very high (about 10,000 volts) potential gradient in a source which can operate at ambient temperatures. While a high-voltage power supply is required, the current demand is low. The technique was first developed by Beckey[41] and his colleagues. The ions formed by this method have very little excess energy, and the relative abundance of the molecular ion is much greater than in most electron impact spectra. A comparison of spectra for n-heptane from the two sources is shown in Figure 5.

The primary advantage of the field ionization technique is the greater simplicity of the spectra, which aids considerably in the analysis of mixtures associated with unresolved GC peaks. The greater abundance of the molecular ion also aids positive identification but some information is lost due to the low abundance of fragment ions. Various researchers have worked on the technique in the last few years. Some of the main difficulties still encountered are in reliably and reproducibly obtaining the same results and in achieving sensitivities equal to the Nier source.

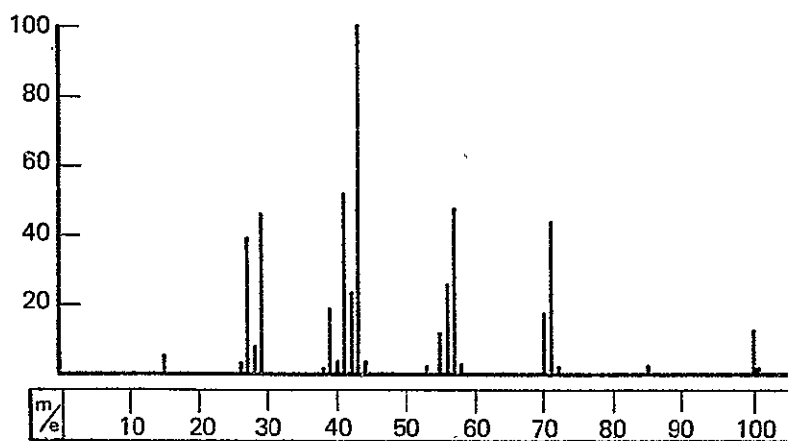

Electron Impact

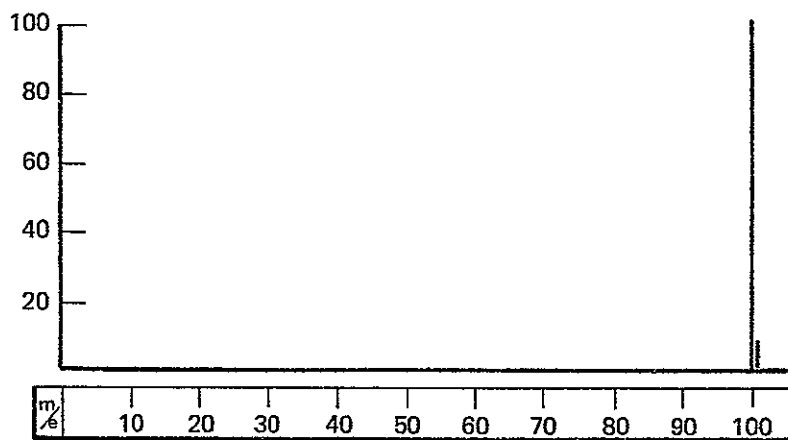

Field Ionization

FIGURE 5 ELECTRON IMPACT AND FIELD IONIZATION SPECTRA OF n-HEPTANE

Sources have been designed using both wires and blades for field ionization. Bryant[43] is currently developing a carbon filament source whose sensitivity promises to be similar to that of electron bombardment sources. One filament has been operating for six months.

The chemical ionization source stems from the work of Field and co-workers at Esso Research and Engineering Laboratories.[44] Ionization is achieved in this source by creating essentially a glow discharge in the source chamber using a gas such as methane at 1-5 torr under high-density electron bombardment. After equilibria are established, the basic ionization mechanisms are

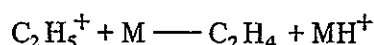
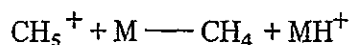

with the first reaction predominating.

The simplicity in mass spectra obtained is similar to that observed by field ionization, except of course for a MH^+ rather than M^+ parent ion, but the sensitivity is substantially better. Because the source operates at higher pressures (1-5 torr vs 10^{-5} torr) and the ionization process is more efficient, the sensitivity of this source may be 100 to 1000 times greater than for the electron bombardment source.

Perhaps one of the more exciting potentials for the chemical ionization source is the possibility of developing a new type of GCMS system using methane as the carrier gas in a high-resolution GC and eliminating the need for an interface, since this ion source can operate at a much higher pressure. Finnigan Instruments Corporation has just announced a commercial GCMS system based on this approach,[45] and several others are conducting research in the area.

Norton Research Corporation has developed an upper atmosphere analyzer utilizing their cold cathode source[46]; this offers yet another means of ion formation, but little is known of its potential for organic analysis. The cold cathode source may have greater lifetime possibilities, but its energy spread limits its usefulness in sector spectrometers.

Our basic conclusion is that a system developed at this time should use an electron bombardment source. As the other source types develop, one may wish to consider dual sources. It will only be after substantial background information and spectra are available that one will be able to consider using the field ionization or chemical ionization source alone. Because it is likely that many

unresolved peaks will be encountered in the GC effluent, it would be highly desirable to have a dual source. Reliability and ease of maintenance of electron bombardment sources has been achieved in commercial residual gas analyzers through redundancy by having two filaments in place and a simple plug-in replacement method.

b. Analyzer

Of the various ion analyzer types available, only the quadrupole and sector-type analyzers are appropriate for practical consideration for the GCMS system task. Flight-qualified hardware has been developed and flown in each category. For many of the space applications for which the spectrometers were developed, there has not been a clear-cut choice between the two basically different types of analyzers. A brief description of them follows.

(1) *Quadrupole Analyzers.* Radio-frequency spectrometers have been built using both a monopole and quadrupole analyzer. Insufficient information is known about the monopole analyzer for us to consider it at this time, so we will restrict our attention to the quadrupole analyzer.

In contrast to the sector spectrometers, which achieve their mass separation by a combination of mass and energy (momentum) resolution, the quadrupole separates ions only according to their mass-to-charge ratio and is not restricted to monoenergetic sources. The quadrupole filter is usually a symmetrical arrangement of conducting circular rods, as shown in Figure 6. Equal and opposite potentials are applied to the two opposite pairs of surfaces. Each potential has a d-c and RF voltage component. When an ion of particular mass-to-charge ratio is injected into the filter, it acquires an oscillation which allows it to be transmitted through the filter at a particular value of the RF and d-c voltage. A mass spectrum is normally obtained by scanning the RF and d-c voltages simultaneously. Narrow mass ranges (1-50, 12-200, 100-300) may be scanned at a single frequency, but wider ranges (12-300) are normally covered in a series of steps at different frequencies. This is principally because of the demands on the RF-dc power supply.

One of the main advantages of the quadrupole over most sector spectrometers is the possible scan time. Scan rates of over 1000 atomic mass units/sec are realistic, while most sector spectrometers will not scan faster than about 200 amu/sec. This factor is most important in GC analysis, but only if the GC peak widths are less than about 1 sec. A major disadvantage of the quadrupole analyzer is its performance deterioration due to contamination build-up of insulating layers on the analyzer rods; this one factor more than any other is the cause for greatest concern in a GCMS system, particularly because there would probably be a regular load on the analyzer due to GC column bleed.

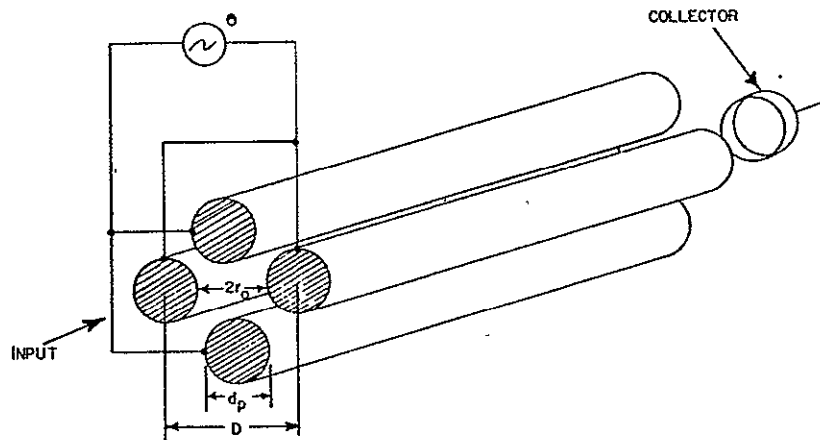

FIGURE 6 SCHEMATIC DRAWING OF QUADRUPOLE FILTER

Many quadrupole spectrometers have been developed and flown in upper atmosphere and space analysis. We have already referenced the work of Narcisi and associates at the Air Force Cambridge Research Laboratories.[40]-In conjunction with Dr. George Carignan, Perkin-Elmer Aerospace Systems has developed a quadrupole spectrometer,[47] that is presently flying in the OGO experiment series. The Norton Research Corporation spectrometer[46] falls in the same category as these instruments, which have a generally usable m/e range of 1-50. Perkin-Elmer has proposed, in conjunction with Bendix as part of the Viking back-up program, to build a flight-qualified quadrupole with a mass range of about 300 and unit resolution at mass 200.

(2) *Sector Analyzers.* Sector analyzers may be divided into two sub-categories — single- and double-focusing.

The single-focusing magnetic sector analyzer has the general configuration shown in Figure 7a. The sector angle, θ , is usually 60 or 90°, although the Dempster spectrometer uses an angle of 180°. Direction (momentum) focusing is achieved in the sector spectrometer when an ion is injected into the magnetic field with a certain velocity. The radius of its path is described by

$$R = \left(\frac{2V}{H^2} \frac{e}{m} \right)^{1/2}$$

where V is the accelerating voltage and H is the magnetic field strength.

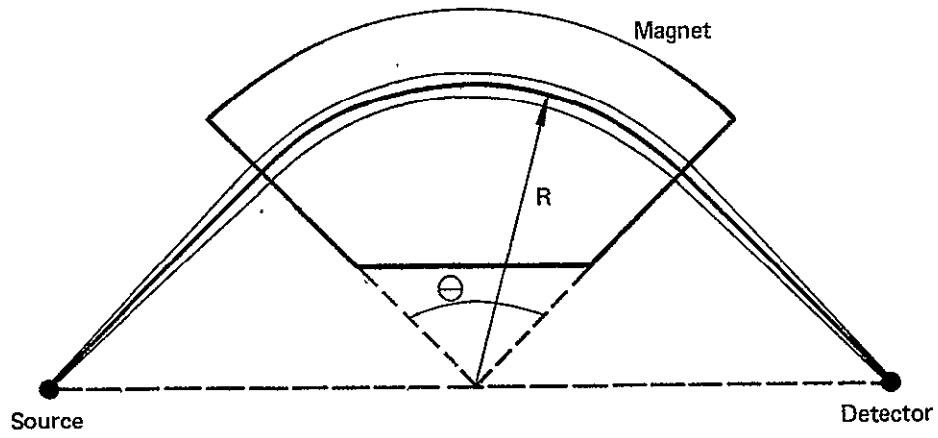

A. General Configuration

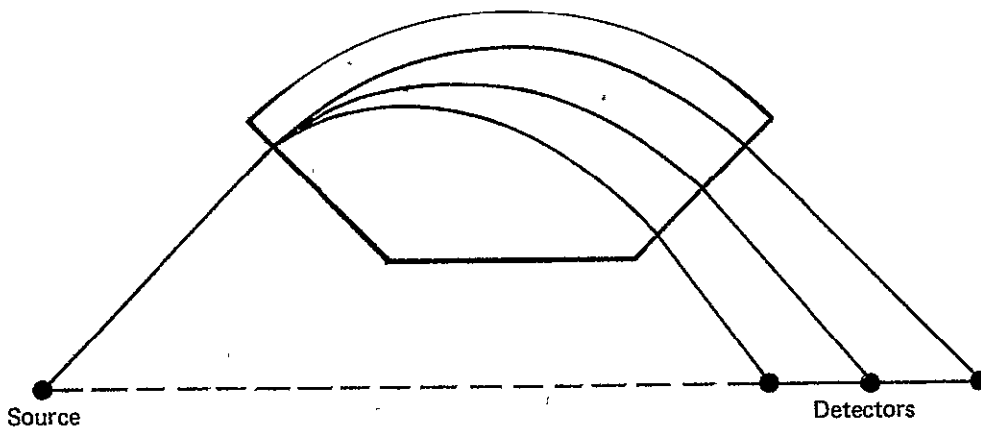

B. Three-Radius Analyzer

FIGURE 7 SINGLE-FOCUSING MAGNETIC SECTOR ANALYZERS

A particular m/e value may be brought into focus at the detector by varying either the field strength or the accelerating voltage. Most laboratory spectrometers scan the field strength using an electromagnet, but instruments developed for space flight scan the accelerating voltage because of the lower overall power requirements.

One disadvantage of scanning the voltage is that the sensitivity varies over a wide mass range. To overcome this problem Hoffman[48] has developed a magnetic sector spectrometer (for lunar atmospheric analysis) with both two and three separate radii and detectors associated with a single magnet. A three-radius analyzer is depicted in Figure 7b. With this configuration, mass ranges 1-4, 12-48, and 40-160 may be observed in the separate detectors. The instrument uses a magnet with a maximum radius of 2-1/2 inches and has unit resolving power at m/e 135 (1% cross talk definition).

Perkin-Elmer has developed a simple atmosphere sensor[49] for measuring the ambient cabin composition including water, nitrogen, oxygen, and carbon dioxide. The instrument monitors the gases continuously (with a 1-second response time) in a non-scanning mode. The detector package weighs 6 pounds and has a power consumption of 3.7 watts (150 ma at 28vdc).

Although the performance of the single-focusing instrument is theoretically independent of the sector angle, the practical aspects of fringe fields, etc., indicate that better performance is obtained from the larger 90° sector.

The main advantage of a single-focusing magnetic analyzer over the quadrupole and double-focusing sector instruments is in its simplicity. A minimum of electronics is required, and one needs to scan only a single voltage. The disadvantage of the single-focusing sector is that the weight requirements increase markedly when one attempts to cover an extended mass range with unit resolution at the high-mass end. At the present time the double-focusing approach is indicated to cover extended mass ranges of 12-200 or 12-300. However, because of the greater electronic simplicity inherent in the single-focusing approach, we would recommend that a careful trade-off study be conducted between the two methods.

Two principal geometries are used for double-focusing spectrometers, one by Mattauch and Herzog, the other by Nier and Johnson. These are represented in Figure 8. Each of the spectrometers utilizes energy and mass direction focusing in the electrostatic (ESA) and magnetic analyzer sections respectively. The main difference in the two is that while the Nier-Johnson optics have only a focal point as a detector, the Mattauch-Herzog optics have a focal plane where all masses are simultaneously in focus at a given magnetic field setting. The Nier-Johnson

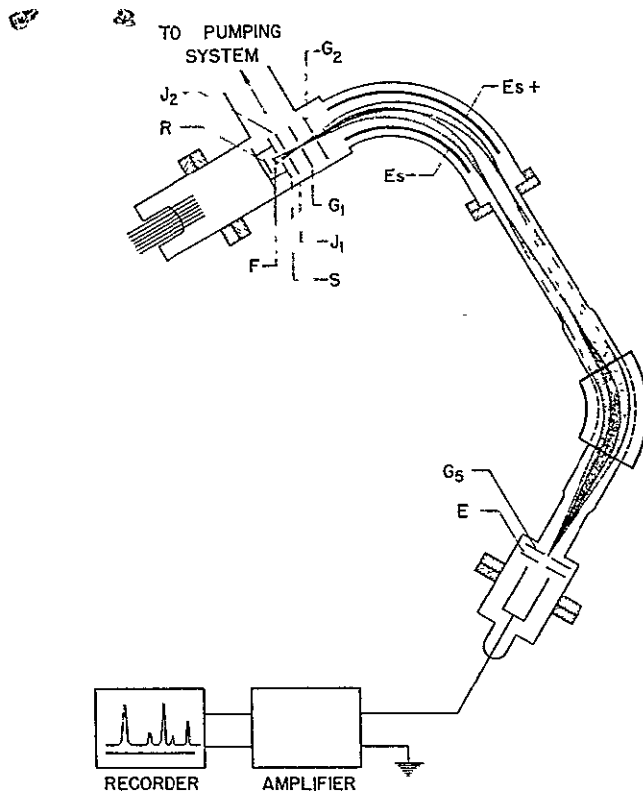

a. Nier-Johnson

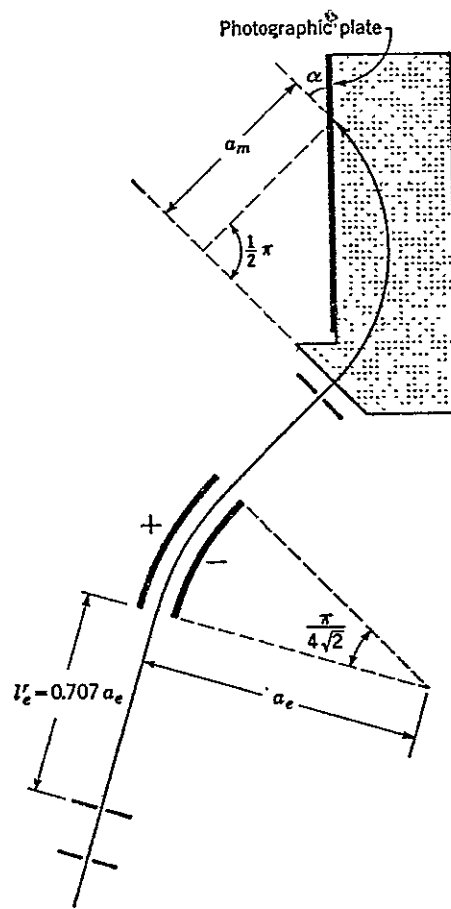

B. Mattauch-Herzog

FIGURE 8 DOUBLE-FOCUSING ION OPTICS

spectrometer must be operated in a scanning mode (for more than one species), while the Mattauch-Herzog spectrometer may be fitted with several detectors in the focal plane for continuous recording of several peaks, or may also operate in the scanning mode.

On an in-house program, the Flight Research Center has continued the development of the Consolidated Electrodynamics Corporation (Bell and Howell) miniaturized Mattauch-Herzog spectrometer for airplane flight.[50] The instrument was designed for ambient atmosphere analysis. It has five channels for recording H_2O , N_2 , O_2 , CO_2 and hydrocarbons by scanning m/e 47-200. It has about a 10-ppm sensitivity using electrometer detection, a mass range of m/e 200, and a 1% valley resolution at m/e 60. Its weight is about 39 pounds, and its power requirement is 35 amperes at 28 vdc. This particular instrument would require a substantial improvement in capabilities before it would be acceptable for the GCMS system.

We believe that the Nier-Johnson geometry is inherently the more desirable of the two approaches for the GCMS system. Nier first published a miniature version of the high resolution Nier-Johnson spectrometer in 1960.[51] The specific initial emphasis in the instrument design was for space analysis. The resolution advantages obtained from a double-focusing instrument compared with a single-focusing instrument with the same mass dispersion are shown in Figure 9.

Since that time, both Perkin-Elmer and the Jet Propulsion Laboratory (JPL) have carried forward the development of the double-focusing Nier spectrometer for deep space exploration. JPL is currently optimizing the design of a package for the Viking mission.[52] The present state of development has achieved a spectrometer with resolution of between 1/200-1/330 over a mass range of 12-200. The spectrometer utilizes a 1.5 in 90° magnet and 1.86 in ESA. It is expected that a version operating with the ion source at $200^\circ C$ will require about 15 watts and weigh about 9 pounds. About 6 watts is required just for the source heating. The instrument has a detection sensitivity of 2.5×10^{-8} amp/nanogram/sec with a minimum detectable signal of 10^{-11} amp, resulting in a net sensitivity of 4×10^{-4} nanogram/sec and an estimated requirement for 4×10^{-2} nanogram/sec for usable spectra. With GC peak widths of 5 seconds for the GCMS TCM, it would mean a minimum detectability of 1 nanogram, which would correspond to a sample requirement of about 1 cc of atmosphere containing 1 mg/m^3 of contaminant.

We recommend that careful consideration be given to modifying the JPL design to satisfy the trace contaminant analysis needs, particularly in view of its present advanced state of development. The one complication in the double-focusing design is that the accelerating voltage and + and - plates of the ESA must all be scanned synchronously.

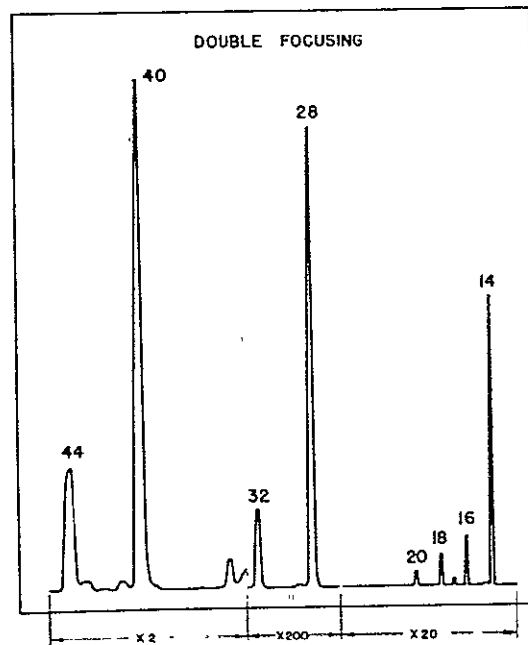
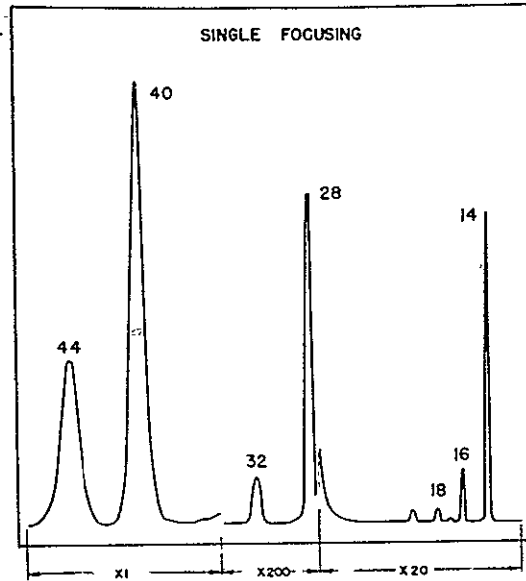

FIGURE 9 COMPARISON OF SINGLE- AND DOUBLE-FOCUSING SPECTROMETERS WITH THE SAME DISPERSION

4. Data Collection and Processing

a. Collection

Of all of the techniques developed in the past few years, perhaps the best means of acquiring the basic GCMS data is in the manner described by Hites and Biemann.[53] In their approach, the raw data is collected in the digital mode under computer control by automatically scanning the MS at a regular frequency while the GC run is in progress. Using their Hitachi spectrometer, scan times of 3 seconds cover a mass range of 10-600. The individual spectra are then summed for total ion intensity, and a plot of total ion intensity versus spectrum number (time) gives a gas chromatographic elution profile. The approach has the basic advantage of being simple and reliable and less likely to miss valuable information than other approaches. It has been adopted in the JPL design, with further modification for simplicity in transmission of the basic data.

b. Processing

The spectra obtained from the GCMS can be evaluated by first comparing them against a reference file of known contaminants stored in the on-board computer. File searching can be achieved by several means, and a detailed study will have to be carried out to determine the most appropriate method. The basic objective is to use the minimum amount of data needed to positively identify a compound.

A first criteria could be that it must satisfy a certain elution region from GC. Then the appropriate range of MS file spectra would be searched. The methods developed by the group in Aldermasten[54] have been successful in identifying compounds from reference spectra by looking only for the "goodness" of fit of either the 5 or 10 most intense peaks in the spectrum. Biemann and co-workers[55] have developed an alternative, also successful, method by comparing the single most intense peak in regions of 14 mass unit increments.

When a known compound was identified, the reference files would then direct the appropriate use of the information. If a compound was not identified, all of the available data would be transmitted to ground stations for interpretation. On the ground, higher intelligence programs, such as those being developed by Morrison,[56] might be able to solve the problems in conjunction with an analyst, or the problem might be best solved by an analyst experienced in the details of the spacecraft.

5. Conclusions

The GCMS presently under development at JPL represents the best state-of-the-art development of a system suited for the task of total spacecraft contaminant analysis as the ICM. We recommend that the JPL system be accepted as a baseline reference for a detailed trade-off and optimization study for a system designed for the specific task of an ICM. In particular, the following areas should be studied:

- Potential of thermoelectrically cooled sample trapping.
- GC column optimization — type of column, nature of stationary phase and support.
- Optimum GCMS interface.
- MS ion source — particular attention to dual-purpose source and/or chemical ionization.
- MS analyzer — weight, power, performance, state of development trade-off — single and double focusing and quadrupole.

B. INFRARED CORRELATION SPECTROMETRY/INTERFEROMETRY

As discussed in Section VI-C, infrared analysis utilizing correlation techniques in either a dispersive (spectrometric) or interferometric mode appears to be one of the most practical and promising means of satisfying the needs of a CCM. A detailed discussion of these methods is given in the following sections.

1. Principles of Correlation

There are several ways in which conventional spectroscopic methods can be used to detect and measure trace atmospheric contaminants or fire precursors. In general, the straightforward spectroscopic methods have serious practical shortcomings — e.g., the need for a skilled operator, long measurement times, lack of sensitivity, and temperamental equipment. Many of these difficulties stem from the excess of information produced by the sensor subsystem. Since the trace gas contaminants to be measured in a CCM are predetermined, it seems desirable to limit the flow of information to that required to detect and measure the gases of interest.

Correlation spectrometry and correlation interferometry are techniques to limit data flow by selecting the most useful data. In correlation spectrometry,

substantial signal processing is accomplished in the optical system, and a minimum of information is delivered to the electronic/logic subsystem and subsequently analyzed. In correlation interferometry, the burden on the electronic system is reduced by placing an electro-optic processor between the primary sensor and the main electronic system. The common feature of the two systems is that the spectral information (deployed in space in one case and in time in the other) is compared with the predetermined spectral signature of the gases of interest. The degree of correlation between the unknown and the reference signatures is used to indicate the presence and quantity of gas.

It is important to recognize that the use of correlation methods does not change the basic electro-optical tools for spectral analysis — rather, correlation uses signal processing techniques which will enhance the utility of the basic tools by offering simpler, more reliable, faster performance for a specific problem.

In a strict sense, the term “correlation” could be applied to a system in which complete spectral data are obtained (i.e., *all* the data are collected) and a sophisticated computer program would correlate the data with a catalog of reference data. Although this approach is workable in principle, the practical difficulties and complexities of processing large quantities of data make it less desirable than one using more subtle, if less universal, electro-optical strategies to process the data. Preliminary evaluation also suggests that simpler, more reliable methods may achieve the desired goals of the CCM. A computer-based system, however, could be a convenient standard against which other approaches might be measured, and might ultimately be required if the interference problem becomes too serious for the simpler methods.

The correlation techniques require that the trace gas contaminants to be measured be identified in advance. In actual spacecraft applications, there may also be a need to monitor constituents of previously unrecognized importance. Implementation of a new correlation data channel during a mission is very unlikely; however, an instrument configuration which allows an astronaut to circumvent the correlation process and use the sensor and electronic system in a more conventional spectroscopic mode has a significant advantage.

2. Methods of Correlation Spectrometry/Interferometry

At this time two fundamental instrument concepts have been demonstrated for correlation analysis: dispersive spectrometry and interferometric spectrometry. Although both are suited to the CCM task, they offer quite different features and capabilities. These differences are most important in a final detailed instrument design.

On the basis of the limited information available at present, dispersive spectrometry seems to have a slight advantage for the CCM subsystem. However, the selection of the method must await detailed examination of trace contaminant spectra, evaluation of the interference problem, and the results of engineering trade-off studies and analyses. Both techniques are discussed below along with some of the criteria one would use to select the preferred technique.

a. Correlation Spectrometer

The most convenient type of dispersive spectrometer to be used is probably a grating monochromator of the Ebert type. The monochromator design is straightforward and is described in standard texts[57]; here we will discuss only the correlation and electronic signal processing methods.

The basic layout of the spectrometer is shown in Figure 10. The spectrum is presented in the image plane, and the absorption lines of the gases of interest are arranged to correspond to the open slits of the correlation mask in the neutral position. Each absorption line has its own slit if there is no interfering absorption line from another possible atmospheric constituent. The spectrum is made to oscillate about this neutral position with an amplitude of approximately the width of an absorption line at a convenient frequency, say 100 Hz. The detector, located behind the mask, sees alternately high and low radiation levels as the absorption line alternates off then on the slit.

This spatial scanning is conveniently accomplished by placing an optical flat in the path near the spectrometer entrance slit. When this plate is oscillated, as shown in Figure 10, the apparent position of the slit moves, and thus the spectrum (i.e., the monochromatic images of the entrance slit) is scanned across the correlation mask. Angular amplitudes of plate movement of 10° to 15° can cause the necessary movement of the spectrum — a few thousandths of an inch.

Multiple gases can be detected simultaneously by providing an array of correlation masks. If the absorption bands fall at separate wavelengths, masks and detectors are placed in the proper location in the spectral plane for each gas of interest. If the absorption bands overlap but the fine structures of the absorption lines do not interfere, a beam splitter could be used to obtain two spectral planes, or masks, and detectors could be placed one “above” the other, each using only part of the entrance slit.

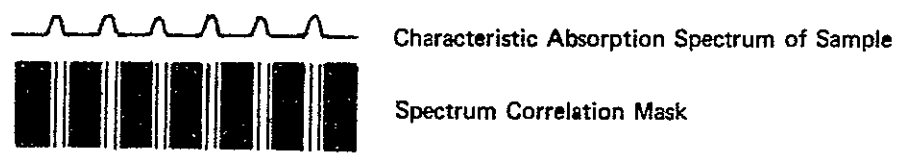
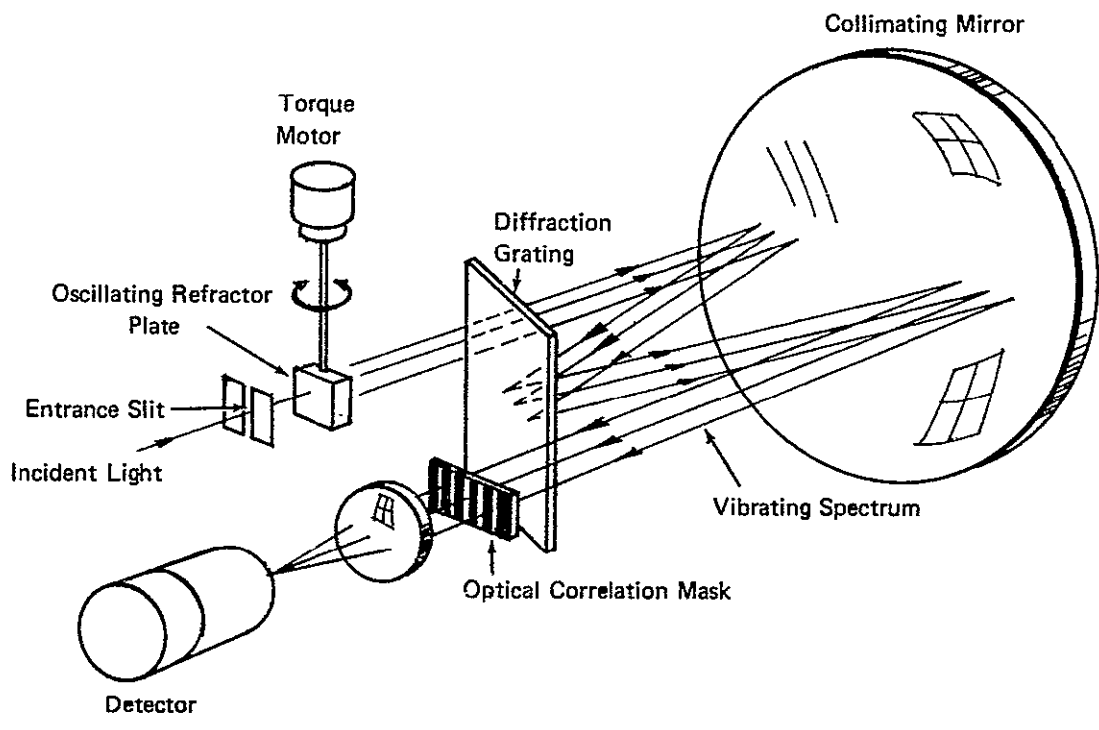

FIGURE 10 SCHEMATIC OF CORRELATION SPECTROMETER

An important feature of this approach is the high degree of specificity which has been observed. Only the gas which has exactly the right fine structure in its absorption spectrum to match the mask will cause maximum modulation of the signal. Further rejection of stray and unwanted signals (as well as system noise) is provided by phase-sensitive amplification of the detector output. The desired modulation is in exact phase with the plate rotation, and the torque motor drive can be used as a reference for synchronous detection. Interference may be further minimized by eliminating known interfering regions from the correlation mask.

The optical masks reject most of the energy of the source. Each slit in the mask should be matched to the resolved absorption line, and scanning should move the spectrum only far enough to take the absorption line off the slit. Since information is taken from a small part of the spectrum i.e., just where it is changing – the system looks only at the important features of the absorption signature and not the vast uninformative region between the lines. The system is responsive to the *differences* in spectral regions, and it operates in a way which maximizes those differences.

b. Correlation Interferometer

The Michelson configuration has become the standard for interferometric spectroscopic measurements. This device has been adequately described in the literature.[57] Here, we will discuss the methods of implementing correlation.

It seems clear that correlation should be attempted on the interferogram directly, because there is no apparent gain in recovering the total spectrum. Information in the interferogram is produced as a function of time; for convenience, the reference interferogram should be stored in such a fashion that it can be recovered and manipulated in synchronism with the newly generated interferogram of the unknown gases. Mechanical coupling of the scanning mechanism and the reference interferogram is probably the best approach.

Scanning requires that the effective optical path length in one arm of the interferometer be regularly, accurately, and reliably changed. This is conventionally done by moving the return mirror in this arm, which is a satisfactory method for the instrument we are considering. Another method[58] is to place an optical flat in the variable arm and rotate it to vary its thickness along the optical axis; although this is a more convenient configuration, it is potentially hazardous because of the reflection losses at the two extra surfaces and the dispersion in the flat. Detailed engineering analysis would suggest the most useful design.

The storage medium for the reference interferogram(s) is very important in the instrument design. Magnetic tape or disc memories coupled to the mechanical scanning assembly are two possible approaches. However, the linear velocity requirements for high-fidelity recording and playback place additional constraints on the scanning rates. Furthermore, the magnetic memory is subject to deterioration and accidental erasure. An optical memory would be speed-insensitive and possibly more stable. Figure 11 is a highly schematic representation of a possible configuration. A photographically generated mask attached to the scanning mechanism is moved past a light source and detector system so that the reference interferogram is reproduced in synchronism with the scan.

c. Nondispersive Correlation

Another system that makes use of correlation techniques is based on a cell filled with the gas to be analyzed. There are a number of schemes for carrying out the required modulation,[59] but a simple conceptualization would be to alternate the instrument's optical path between an empty cell and one containing the gas in question; radiation that has the spectral characteristics of the appropriate gas changes the signal in the empty cell but not in the full cell, providing the required modulation. Most other radiation produces identical effects in both cells, thus providing no modulation.

This correlation technique requires no dispersive device and possesses the spectral resolution of the gases of interest, but it has serious limitations due to absorption by other interfering species. Another disadvantage is the need to keep samples of the gases of interest onboard the spacecraft.

3. Sensitivity

We have made a series of calculations to estimate the approximate sensitivity which a correlation spectrometer might have for a particular gas of interest. The calculations used the following basic assumptions:

- Gas — Carbon monoxide
- Spectrometer — Ebert
PbSe detector
16 cm focal length
3000°K tungsten filament source
- Sampling — Folded reflecting telescope, 38 cm focal
length, 10.8 cm aperture

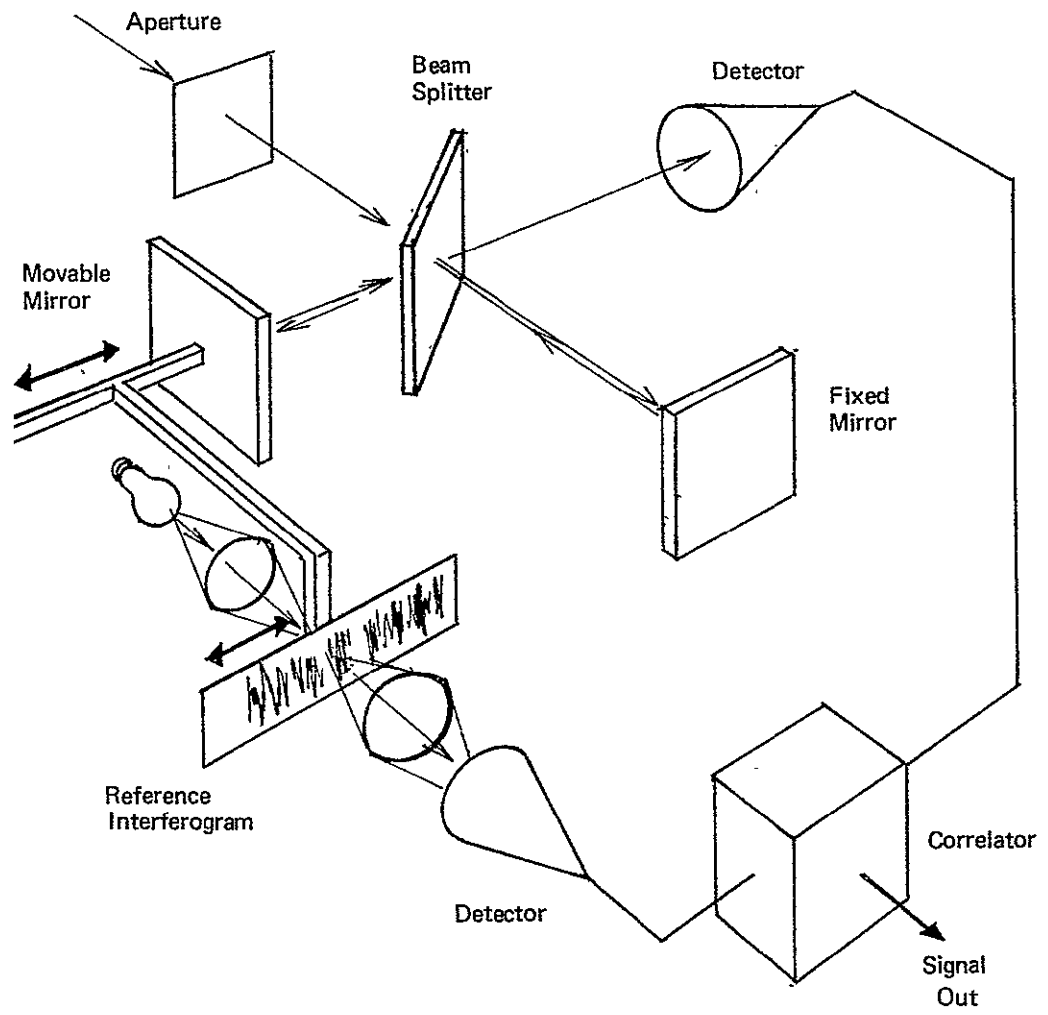

FIGURE 11 SCHEMATIC OF CORRELATION INTERFEROMETER

A minimum detectable concentration of 2×10^{-6} atm/cm (~ 2 mg/m³/cm) of carbon monoxide was calculated using the absorption in the region of 2.4μ . For any optical path length longer than 20 cm, the minimum detectable concentration is well below 1 mg/m³ (in a 15-psi atmosphere), even if the detector noise is higher than assumed and the detector/mask configuration is less than optimum.

4. Spectral Considerations

a. Selection of a Spectral Range

The feasibility of using an optical correlation instrument as a CCM in monitoring trace gas contaminants will be determined in part by the spectra of the gases to be measured and the interference from background gases. The requirement for successful discrimination is the presence of recognizable features in the spectrum of the gas to be measured that are not significantly obscured by the spectra of interfering species.

Selection of the preferred spectral range for the construction of a single correlation device depends upon several interdependent considerations, such as source optics and detector characteristics, resolution, and the nature of the spectra of the species selected for monitoring. The ultraviolet, visible, and infrared regions are available for the development of an optical correlation CCM based upon absorption phenomena.

The probability of designing a successful correlation instrument is partly proportional to the number of absorption features examined. Therefore, the broadest spectral range and the smallest resolution element possible are desired. Broad spectral resolution elements effectively smear the spectral lines; this reduces specificity as well as intensity, because broadened absorption features are more likely to be overlapped by interferences than are narrow lines. When the spectra consist of broad bands with unresolvable fine structure, correlation spectrometry using a relatively small mask may be less desirable than correlation interferometry, because the interferogram contains information on all the frequencies within the pass band at every point. Thus, widely spaced broad bands may provide correlatable structure in the interferogram.

While some gases of interest such as sulfur dioxide, nitrogen dioxide, and chlorine have absorption bands and fine structure (vibrational and rotational) in the usable ultraviolet-visible (UV-Vis) range, many of the other gases such as HCl, HF, CO, and NH₃ that must be monitored by the CCM do not possess sufficiently intense absorption bands in the practically accessible region of the UV-Vis spectrum. Furthermore, it is more difficult to resolve the rotational fine structure in this spectral range than in the infrared, and a system developed for the UV-Vis would probably utilize only the vibrational fine structure. The vibrational line

widths in the UV-Vis range for sulfur dioxide are about 2 nm, which leads to only about 250 resolution elements in the available 250-750 nm range.

In contrast, almost all of the species of interest have absorption and rotational fine structure with sufficient spacing ($<0.1 \text{ cm}^{-1}$) in the infrared region of the spectrum to allow one to accomplish the desired correlation task. If we consider the potential information content, with a line spacing of 1 cm^{-1} , 3600 resolution elements are available in the $4000\text{-}400 \text{ cm}^{-1}$ infrared range, making this a potentially more useful region in which to work.

Nevertheless, the generally higher extinction coefficients and, therefore, greater detection sensitivity associated with the UV-Vis vibrational transitions justify careful consideration of all the tradeoffs involved before a final choice is made.

b. Absorption Spectra of Trace Contaminants

Our initial evaluation suggests that the normal infrared region ($2.5\text{-}40 \mu\text{m}$, $4000\text{-}400 \text{ cm}^{-1}$) possesses the highest potential for the development of an effective CCM. Therefore, we have examined the spectra of several selected species in detail to assess more accurately the ultimate potential for the development of a reliable, practical correlation instrument and to determine the frequency range which must be analyzed in order to measure all of the selected trace contaminants.

The literature was examined for data on CO, HCl, HF, COF_2 , COCl_2 , CH_4 , NH_3 , SO_2 , NO_2 , $\text{C}_3\text{H}_4\text{O}_3$, CH_2O , N_2H_4 , $(\text{CH}_3)_2\text{N}_2\text{H}_2$ (sym. and unsym.), C_2HCl and C_2Cl_2 . The quality of the spectra varied considerably, for a variety of reasons. A summary of the observations for each gas is given below:

- *Carbon Monoxide (CO)*. This can best be detected in the $4.6 \mu\text{m}$ region ($2000\text{-}2250 \text{ cm}^{-1}$). [60] This is the fundamental stretching region and has excellent rotational fine structure well suited to dispersive optical correlation with a minimum of atmospheric interference. A spectral resolution of 1 cm^{-1} is appropriate.
- *Hydrogen Chloride (HCl)*. Like CO, the most useful structure of HCl is in the region of the fundamental vibration near $3.5 \mu\text{m}$ ($2650\text{-}3050 \text{ cm}^{-1}$, see Figure 12), again in a region of relative atmospheric transparency. [60] The fine structure can be easily observed with a 10 cm^{-1} resolution element, and the lines of $\text{H}^3\text{7Cl}$ can be distinguished from $\text{H}^3\text{5Cl}$, effectively doubling the number of useful lines if a

resolution element of ca. 0.7 cm^{-1} is used. Again, dispersive optical correlation is an excellent choice.

- *Hydrogen Fluoride (HF)*. The similar fundamental for HF near $2.5 \mu\text{m}$ ($3500\text{-}4300 \text{ cm}^{-1}$)[61] is seriously overlapped by atmospheric H_2O and CO_2 . However, the higher frequency part of the HF fine structure between ca. 4000 and 4300 cm^{-1} could be utilized. Alternatively, the first overtone near $1.3 \mu\text{m}$ ($7300\text{-}8000 \text{ cm}^{-1}$), which is of course not as strong a band but is completely free of atmospheric interference, could be used. Relatively low resolution (ca. 20 cm^{-1}) is all that is required, but, as in all these cases, higher resolution improves the selectivity and sensitivity of the system by sharpening the lines. Dispersive optical correlation is again a good possibility.
- *Carbonyl Fluoride and Chloride (COF_2 and COCl_2)*. The spectra of COF_2 and COCl_2 have been measured under prism resolution.[62] (See Figure 13.) They show many vibrational absorption bands spread out over the infrared region between 300 and 4000 cm^{-1} . Under this relatively low resolution most bands show some structure. Under higher resolution, Nielsen[63] was able to resolve the rotational lines only for the band between 740 and 800 cm^{-1} for COF_2 . The line spacing was ca. 0.7 cm^{-1} , so this band is the best candidate for dispersion optical correlation and, fortunately, is one of the stronger bands of the material. However, there are several strong bands, so a filter radiometer and complete spectral analysis may be more sensitive than optical correlation. CoCl_2 will clearly have higher moments of inertia than COF_2 with correspondingly smaller line spacings, so dispersion optical correlation is not a likely choice except under exceedingly high resolving power. Correlation interferometry, by utilizing more of the spectral data, is a possibility here. Complete spectral analysis, filter radiometers, and nondispersive infrared techniques are alternatives.
- *Methane (CH_4)*. The strongest bands of methane are in the $7.5 \mu\text{m}$ ($1200\text{-}1400 \text{ cm}^{-1}$) and $3.3 \mu\text{m}$ ($2900\text{-}3150 \text{ cm}^{-1}$) regions.[60] Both bands provide excellent rotational structure for correlation spectrometry and are only moderately troubled by water vapor absorption. A resolution element of 2 cm^{-1} is more than adequate for much of the structure, although another factor of about 5

to 10 is required to make the most of the structure in the 7.5 μm region. A combination band near 2.3 μm that is reasonably strong is also available[64] and has essentially no atmospheric interference.

- *Ammonia (NH₃)*. The strongest band of ammonia extends from about 8 to 14 μm (750-1200 cm^{-1}).[60] It is an ideal candidate for correlation spectrometry, having not only ample structure that is readily available, but being precisely situated in the best atmospheric window in the infrared region of the spectrum. A 2 cm^{-1} resolution element is again ample to provide considerable structure. As before, a considerable improvement in sensitivity and specificity can be obtained by using higher resolving power. A suitable combination band which is somewhat weaker is available near 2.3 μm .
- *Sulfur Dioxide (SO₂)*. The spectrum of sulfur dioxide shows the strong fundamental ν_1 absorption near 9 μm (1110-1190 cm^{-1}). This band is a good candidate for correlation spectroscopy, as it is relatively free from atmospheric interference. A moderately strong combination tone near 4 μm with even less atmospheric interference is also available. Considerable rotational structure has been observed for the bands of this molecule.[65] We would recommend the ν_1 fundamental, for which a resolution element of about 1 cm^{-1} is adequate.
- *Nitrogen Dioxide (NO₂)*. The spectrum of NO₂ is complicated by the equilibrium involving N₂O₄. The amount of interference is a function of concentration and temperature and would have to be considered in an experiment where there is overlap between the spectra of the two molecules. The strong bending fundamental of NO₂ near 13 μm (650-900 cm^{-1}) has an easily resolvable structure[66] that could be used in a correlation spectrometry experiment. The required resolution is only on the order of 5-10 cm^{-1} . The higher frequency portion of this band should be used to avoid both N₂O₄ and atmospheric CO₂ absorption. Alternatively, there are many bands in the overtone and combination tone region that might be used.[67] They show excellent fine structure and resolutions of approximately 0.5 cm^{-1} . The strongest of these bands occurs at 2905 cm^{-1} , but the results for it were unfortunately not shown. Other candidate bands are

the absorption near $2.4 \mu\text{m}$ ($4100\text{-}4200 \text{ cm}^{-1}$) and $2.1 \mu\text{m}$ ($4690\text{-}4770 \text{ cm}^{-1}$).

- *Pyruvic Acid* ($\text{C}_3\text{H}_4\text{O}_3$). A low-resolution spectrum of pyruvic acid shows only broad vibrational structure.[68] The relatively large size of this molecule suggests that very high power would be needed to resolve its rotational fine structure. Thus, correlation interferometry is probably a better choice in this instance.
- *Formaldehyde* (CH_2O). Unlike the previous linear diatomic molecules, formaldehyde offers many regions of spectral absorption.[69] The best regions for our purpose are one near $3.5 \mu\text{m}$ ($2600\text{-}3000 \text{ cm}^{-1}$) and a second centered near $9 \mu\text{m}$ ($1000\text{-}1330 \text{ cm}^{-1}$). The resolution required to utilize the fine structure is somewhat variable, depending on the precise spectral region chosen, because of the complicated nature of the spectrum. It would appear that a 0.5 cm^{-1} resolution element would provide good structure for dispersion optical correlation, although 0.1 cm^{-1} might be significantly better. With this kind of molecule, much of the useful information is spread over a broad band of wavelengths. This suggests the value of correlation interferometry or complete spectral analysis.
- *Hydrazine* (N_2H_4). The strongest band in the hydrazine spectrum is near $10.5 \mu\text{m}$ ($750\text{-}1150 \text{ cm}^{-1}$) and shows considerable structure even under prism resolution.[70] 5 cm^{-1} should be adequate, although higher resolution is again to be preferred for both sensitivity and selectivity.
- *Symmetrical and Unsymmetrical Dimethyl Hydrazine* ($(\text{CH}_3)_2\text{N}_2\text{H}_2$). Both of these compounds show extensive vibrational absorption[64] under prism resolution, so many spectral regions could be used for their detection. Rotational envelopes are visible in these spectra, but grating resolution spectra would have to be examined to ascertain if sufficient resolution is present to allow one to use dispersion optical correlation.

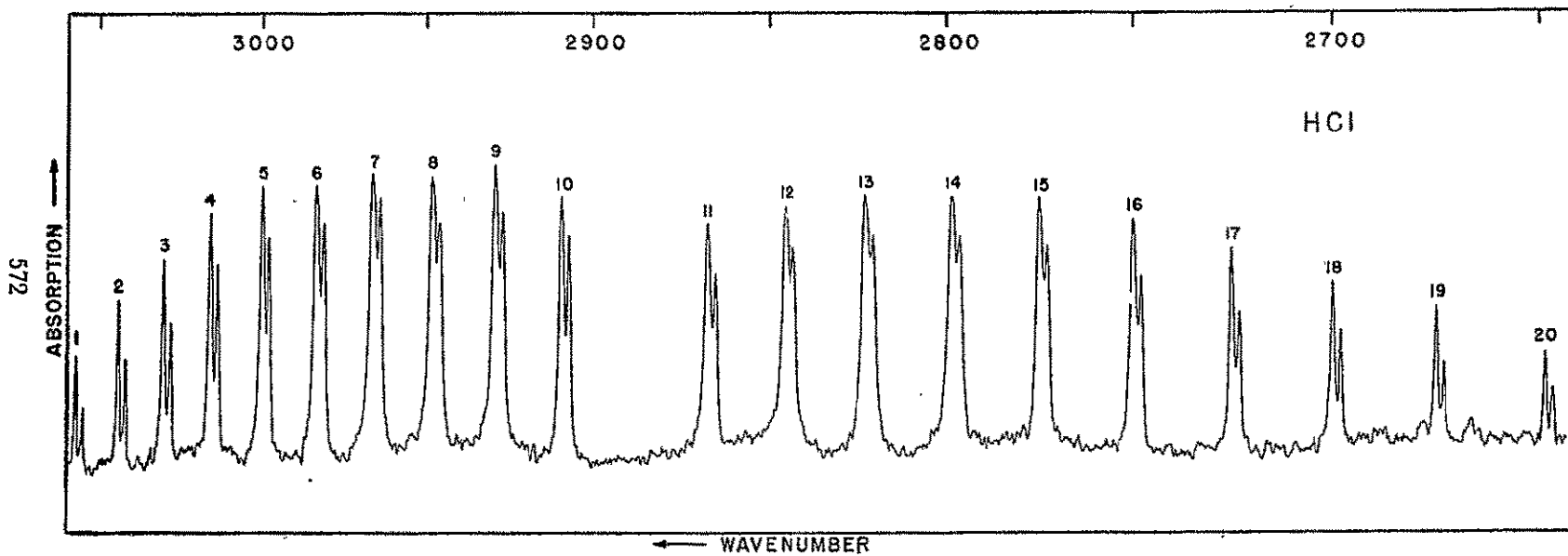

FIGURE 12 INFRARED SPECTRUM OF HCl (2650-3050 cm^{-1} Region)

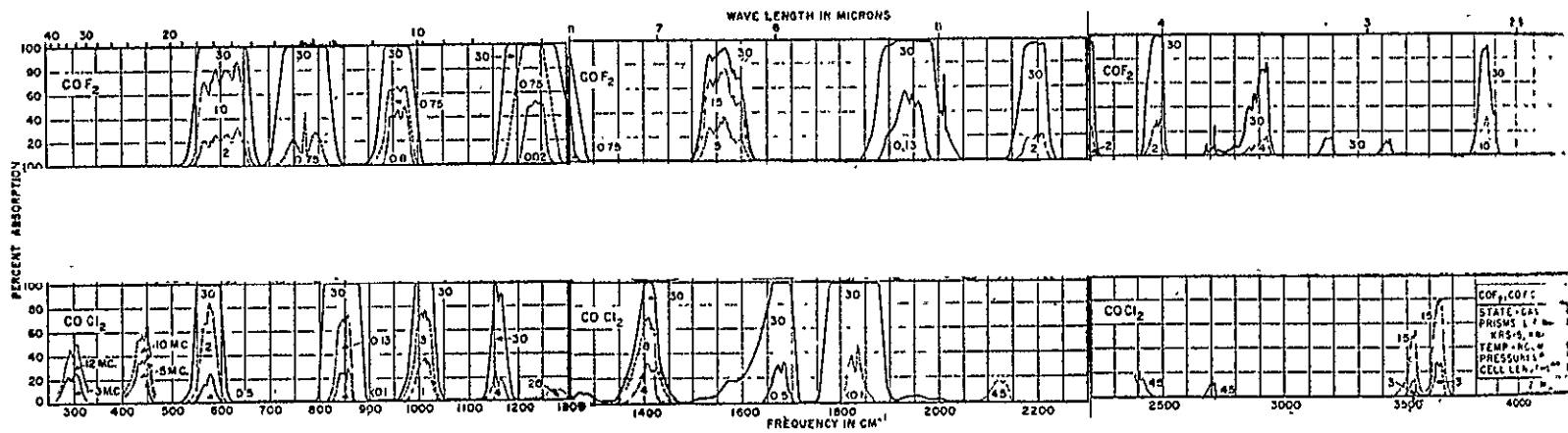

FIGURE 13 INFRARED SPECTRA OF COF_2 AND COCl_2

Chloroacetylene and Dichloroacetylene (C_2HCl and C_2Cl_2). We have not been able to find a spectrum of dichloroacetylene, but monochloroacetylene has been examined under relatively low resolution.[71] There are many bands, but higher resolution is necessary to permit the required fine structure to be found for dispersion optical correlation techniques. The large moments of inertia of these molecules suggest that very high resolution ($\sim 0.05 \text{ cm}^{-1}$ for C_2Cl_2) would be required. Therefore, complete spectral analysis, correlation interferometry, etc. may be necessary.

Background Interferences

Spectral discrimination of a particular gas in the presence of other trace contaminants consists of ascertaining the line or band positions and strengths in the presence of many similar features caused by the interfering species. The spectra are generally quite complex, and while some overlapping of features is to be expected, it is unlikely that all regions of diagnostic information will be obscured. Correlation instruments are designed to use the specificity of the spectral information, so the effects of interference are greatly reduced. Completely successful discrimination of one species in the presence of background interferences requires a complete knowledge of the spectra of the background species. Because not all contaminants are known, the best approach is to examine the spectra of expected interferences and to provide the maximum discrimination by using as broad a band of frequencies and as narrow a resolution element as possible. Provided that a sufficient number of spectral resolution elements are examined and allowances for known absorptions are made to minimize the amount of interference, we believe that a correlation-type instrument can be shown to be feasible for monitoring many contaminants.

The principal interferences in the spectral regions of interest for the selected gases will be caused by the H_2O at $2.7 \mu\text{m}$ and in the $5.5\text{--}7 \mu\text{m}$ range and CO_2 at $2.7 \mu\text{m}$, $4.3 \mu\text{m}$, and around $15 \mu\text{m}$ in the system atmosphere. A most important background spectrum, that of expired air, is shown in Figure 14.[72] Identification of the contaminant gas can be carried out in the presence of such major interferences as long as they do not produce complete opacity, but only at the expense of instrument complexity or decrease in the sensitivity and freedom from error. Nonetheless, large spectral regions of relative transparency will probably be available.

Other background interferences will be caused by gas constituents present in relatively small amounts. Although these interferences are serious, because similar chemical groupings give rise to similar spectral absorptions, it is unlikely that any

spectral region will be completely opaque, since the concentrations of the interfering species will be low.

5. Conclusions

The development of a flight-qualified optical correlation instrument which will satisfy the task of a CCM appears quite technically feasible and practical in the near term. Correlation spectrometers have already been incorporated in aircraft for SO₂ and NO₂ pollution analysis, and interferometers are being developed for upper-atmosphere flight studies. Unfortunately, many details are still missing in the final assessment of an instrument which will reliably analyze a specific preselected gas without interference from other trace contaminants.

We recommend that a detailed study be initiated to determine the following:

- Final selection of spectral range;
- Choice between dispersive and interferometric optical design;
- Sensitivity for individual species measurement;
- Specificity in measuring the selected species, with a careful assessment of the magnitude of the interference from other contaminants;
- Number of contaminants which can be analyzed in a single instrument;
- Response time;
- Suitability for use in incipient fire detection as well as trace contaminant analysis.

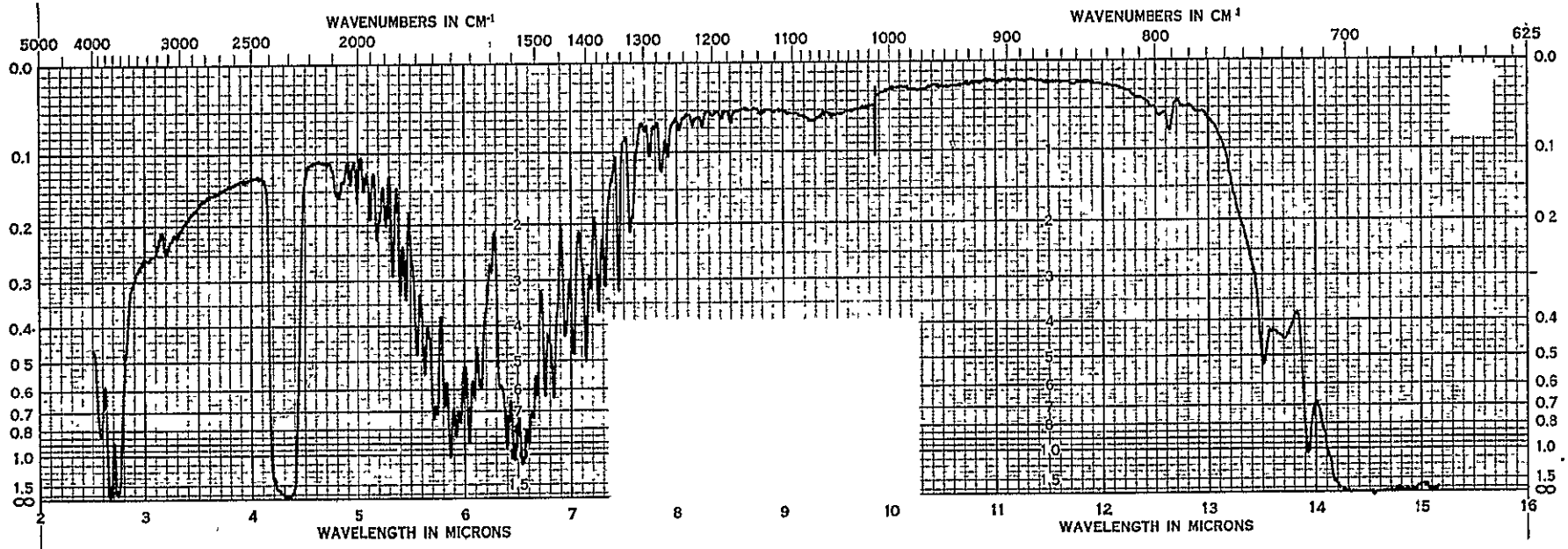

FIGURE 14 INFRARED SPECTRUM OF HUMAN-EXPIRED AIR (10M Cell)

VIII. EXTENDING THE LIFETIME OF THE CANDIDATE TECHNIQUES

Long, reliable lifetime with minimal maintenance is an important attribute for any spacecraft instrumentation. As far as possible, the need for maintenance should be predictable well in advance, so that it can be performed during periods when other activities are at a relatively low level. Components which are subject to unpredictable, catastrophic failure should be redundant. The Onboard Check-out System (OCS) described in Section IX-A is capable of monitoring critical electrical signals that are indicative of instrument or subsystem performance. The digital computer associated with the OCS provides the capability to log performance data, construct trends, and predict the future time when performance will degrade to an unacceptable level. Predictions of this sort and the resulting scheduling of necessary maintenance are discussed in greater detail in conjunction with crew information presentation in Section IX.

With regard to the proposed GCMS system, one of the most important considerations to minimize the possibility that the MS will become contaminated and require disassembly for cleaning; accordingly, detailed attention should be given to the thermal stability of the GC column stationary phase to insure that it does not bleed. This will also help to maximize the useful lifetime of the GC column itself.

The use of a capillary column in the GC significantly reduces carrier gas requirements. To insure reliable operation of the valves associated with the GCMS, particular care must be taken to insure cleanliness. For this reason, particulate filters must be installed in the lines to the valves.

If an MS ion source using a heated filament is finally chosen, dual filaments optimized for long life should be provided. Detecting filament burnout and switching in the spare should be under the control of the OCS. Turning off the filament heater supply when the MS is not in use will both prolong filament lifetime and conserve power.

The possibility that the MS might become mechanically misaligned is an ever-present problem that requires careful design attention. Good engineering design for long, reliable life is of primary importance to avoid failure of the mechanical drive components of the CCM spectrometer. Ease of serviceability should also be a consideration. Incipient failure might well be detected by using the OCS to monitor the electrical power drawn by the drive element. The radiation source is also subject to failure; redundancy with ease of replacement should be provided.

One significant possibility for increasing the reliability of infrared correlation analysis would be to employ optical correlation rather than electronic; elimination of the magnetic recording device and associated electronics would result in an inherently simpler instrument. (The technique of optical correlation was discussed in Section VII-B.)

IX. METHODS OF PRESENTING INFORMATION TO THE CREW

Even the most advanced and sensitive on-board contaminant measurement system is useless unless its data can be assimilated and fed back, in meaningful terms, rapidly and without error, to produce a corrective or protective action. The feedback may conceivably be either direct to the environmental control system, which can implement corrective measures to reduce contaminants, or via displays to the occupants of the spacecraft or the monitors on the ground. This section summarizes our recommendations for the use of control and display facilities to make optimum use of the contaminant level measurements.

An Onboard Checkout System (OCS) with an associated digital computer is under development[73] and will be available for use with the trace contaminant monitoring system. The basic characteristics of the OCS and means of utilizing its capabilities will be discussed.

A. DESCRIPTION OF THE ONBOARD CHECKOUT SYSTEM

The OCS is a digital computer with a highly versatile interface for generating a variety of electrical stimuli and measuring electrical responses under computer control. A simplified diagram of the OCS is shown in Figure 15; a more detailed description of the system may be found in the original design document.[74] Electrical stimuli are generated under computer control in the SGU and subsequently connected to the required test point by the SSU under computer control. Electrical responses are multiplexed into the MU by the MSU. The DIACU is the interface between the test system, the telemetry system, and the digital computer (ADC).

A control and display unit (CADU) is provided for crew communication with the OCS. The CADU has a keyboard for data input and a plasma display screen capable of displaying either graphical or alphanumeric information. A microdata storage and display system provides for economical storage of reference information that does not need to be updated, e.g., repair instructions.

B. TASKS TO BE PERFORMED BY THE ONBOARD CHECKOUT SYSTEM

The role of the OCS in the trace contaminant monitoring process is to assimilate the maximum amount of information about the status of the trace contaminant monitoring system and the results of the measurements the system has made. The real benefit of the OCS is to relieve the crew of routine decision-making while at the same time providing them with the necessary information to make the more complex decisions with maximum efficiency.

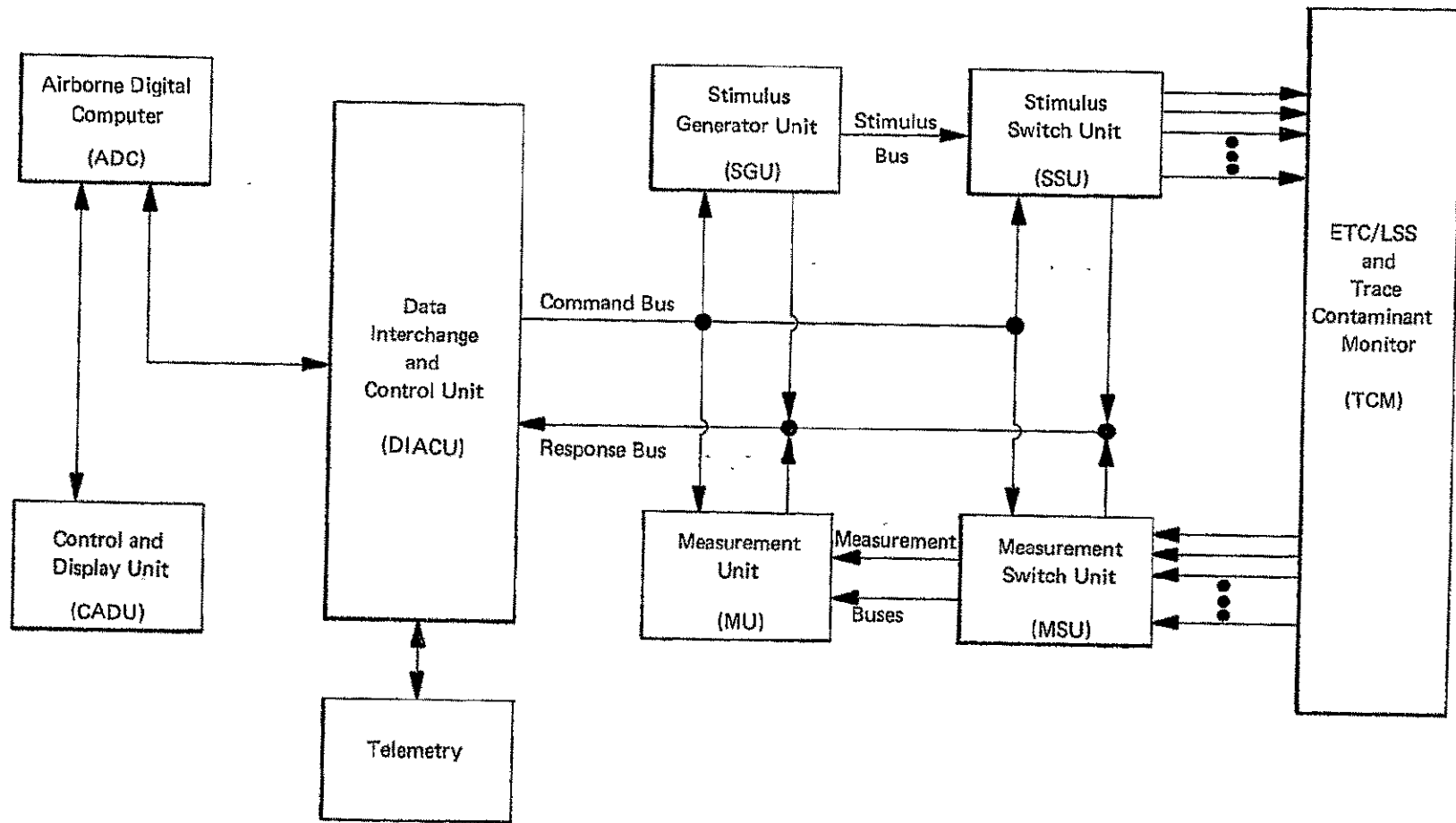

FIGURE 15 SIMPLIFIED DIAGRAM OF THE OCS

1. Automatic Checkout of the Trace Contaminant Monitoring System (TCM)

The most critical check of the TCM is the introduction of a standard sample of gas for periodic calibration of the instrument. From the results, calibration factors which relate instrument output signal to actual contaminant concentration levels are determined and stored in the ADC for calculating the results from the analyses of unknowns. If the calibration factor deviates significantly from its normal expected value, further system checkout is undertaken under computer control.

Electrical signals from test points within the TCM and from transducers that measure important TCM conditions can be monitored by the OCS. The OCS has the capability for isolating a fault to a single replaceable subassembly of the TCM. Design and construction of the TCM should be done with this capability in mind.

2. Logging and Manipulation of TCM Measurements

Data from measurements by the TCM must be input to the OCS for further calculations. In addition to converting the raw experimental data to concentrations, the OCS should calculate trends in the individual contaminant levels on the basis of a series of successive measurements.

As more detailed information with respect to actual contaminant production and removal rates is obtained, it may be possible to predict future contaminant levels with some certainty.

Figure 16 shows a general block diagram for the prediction of spacecraft contaminant concentration based upon measurements or estimates of the following: rate of contaminant generation, current concentration, spacecraft free volume, efficiency of contaminant removal system (percentage of contaminant removed per unit time), and spacecraft atmosphere leakage rate.

The rate of contaminant production may be (1) measured directly by samples taken close to the source, (2) calculated from the Langmuir equation, using knowledge of surface area of material exposed, or (3) estimated on the basis of known contaminant generation rates from materials or human occupants.

The initial condition or current level of free-air spacecraft contamination is measured directly by the contaminant monitoring system; the free volume of the spacecraft cabin is also known, although it may vary in a large spacecraft as additional chambers are opened or closed off.

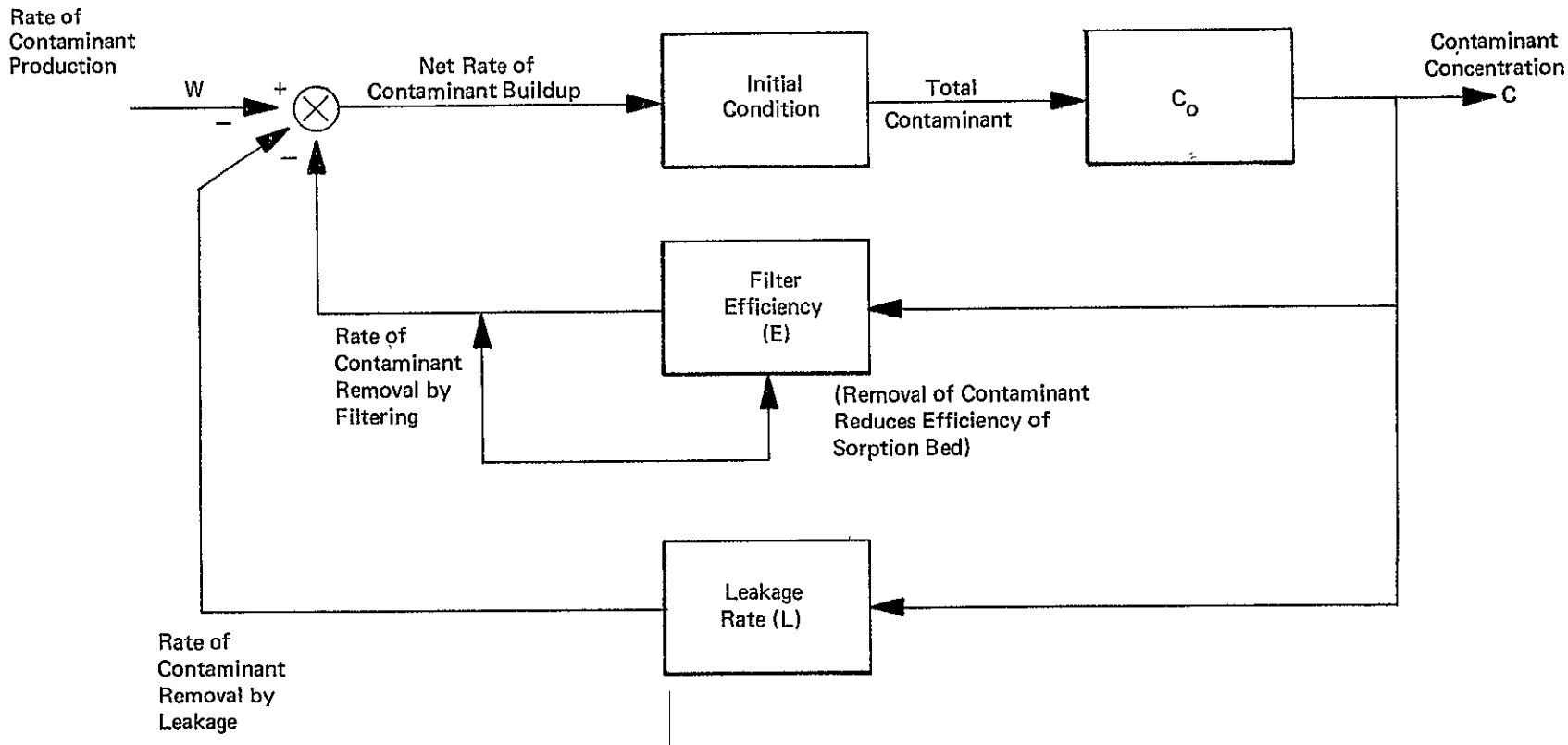

FIGURE 16 PREDICTION OF TRACE CONTAMINANT CONCENTRATION

The rate of contaminant removal by filtering, or filter efficiency (E), may be determined directly by measurement of trace contaminant concentration in the inlet and effluent of the absorption bed or other source of filtering, or it may be calculated on the basis of the known reduction in filter efficiency with use and history of contaminant removal.

Finally, the leakage rate (L) may be measured from the amount of stored gas added to maintain the cabin pressure constant or estimated from pre-launch calculations. Alternate "leakage rates" associated with complete or partial purges of the spacecraft atmosphere can be used for prediction of contaminant concentration reduction with such a purge.

For contaminants such as carbon monoxide, for which sufficient information on the physiological or toxicological behavior is available, the calculation can be extended to predict the actual concentration of the contaminant in the body or parts of the body which set the limitation on allowable exposures. The structure of such a program is shown in Figure 17. On the basis of predicted future spacecraft contaminant concentrations and a knowledge of the physiological absorption coefficient for various parts of the body, storage capacity for the contaminant, and rates of contaminant elimination via air, urine, feces, etc., a predicted storage concentration of the contaminant in the body can be calculated. These stored body concentrations, predicted on the basis of the expected future spacecraft contaminant concentration, would be the ultimate basis for assessing the safety of the spacecraft atmosphere.

3. Crew Information Presentation

Efficient communication of TCM status and contaminant levels can be achieved by a selective inquiry technique utilizing the OCS facilities. A simple green-yellow-red annunciator would indicate the system status. As long as system parameters and contaminant levels were within acceptable limits, the green light would remain illuminated. If any parameter or level was reached or was trending rapidly toward a preset limit, the yellow or red light would be illuminated depending on the severity of the problem; a yellow light would indicate permissible deferred action.

The crew could then interrogate the OCS for an alphanumeric display of the parameter(s) out of limits or trending out seriously. Parameters should be listed in order of priority, depending on the nature of the parameter, its rate of change, and its distance from the limit. Upon further interrogation, the OCS could provide a graphical display of the trend, its future projection, and associated tolerance limits.

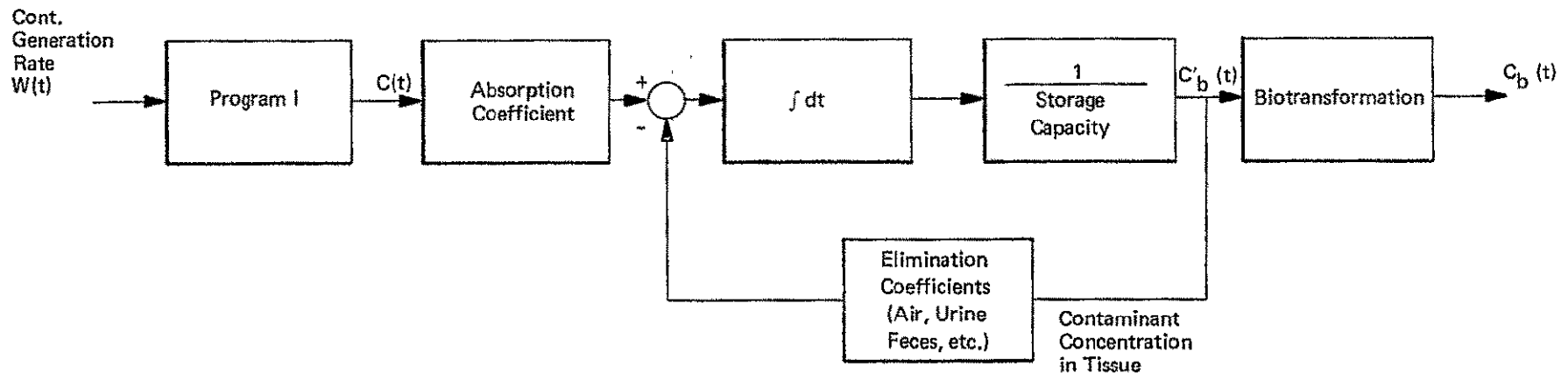

FIGURE 17 CALCULATION OF BODY CONCENTRATIONS OF A CONTAMINANT

If the nature of the malfunction required crew intervention for repair or replacement, the associated data should be automatically available on the micro-data system.

When crew action can be deferred, it should be scheduled into the OCS, at which time the warning light would be extinguished. The warning would reappear only if the trend accelerated or if the accepted schedule was not met.

The CCM system should have its own memory for limits and an annunciator to display out-of-limit species and their location.

X. FEEDBACK OF INFORMATION FOR CORRECTIVE ACTION

Completely automated feedback of all data from the two trace contaminant monitor subsystems to the Baseline ETC/LSS is unrealistic to consider at the present time; the variables involving the details of a particular mission are too numerous to allow one to reliably pre-program all of the possible actions which might be taken if a particular event occurred. Further, the complete behavior of the ETC/LSS is not sufficiently well known to predict with certainty the effect of changes on its control of contaminants.

We recommend that virtually all corrective action feedback be conducted via the spacecraft crew. One exception is described below and should be explored in sufficient detail to allow the decision to be made regarding dynamic feedback possibilities.

In the Baseline ETC/LSS, the primary role of the catalytic oxidizer is to oxidize carbon monoxide, hydrogen, and methane to carbon dioxide and water. The flow rate through the catalytic oxidizer is determined primarily by the carbon monoxide load, and operating temperature is then set by the methane load. In design concepts to date, these parameters would be invariant during the operation of the catalytic oxidizer in space. However, elevated production of flow-limited contaminants such as carbon monoxide can be maintained at safe levels by increasing the flow rate through the catalytic oxidizer. Increased flow rates were used in the MESA experiments[4] to handle an inordinately high hydrogen production rate. Recent design changes in the Baseline ETC/LSS (removing the catalytic oxidizer flow from the main charcoal sorbent flow) indicate that variable flow rate is being considered for the Baseline System.

Contaminant buildup can also occur if catalytic oxidizer efficiency is lost as a result of poisoning by species containing halogens, nitrogen, and sulfur. The main charcoal sorbent and the lithium hydroxide pre-sorbent are believed to be effective in removing the nitrogen and sulfur compounds that are irreversible catalyst poisons. But it has been shown that the presence of very small quantities of low-molecular-weight halocarbons can result in serious losses of catalytic oxidizer efficiency. (The presence of 21 mg/m³ of methyl chloride has reduced the methane conversion efficiency of a catalytic oxidizer to 4%.[3]) This type of reversible catalyst poisoning due to halogenated hydrocarbons is important, because the charcoal and lithium hydroxide beds cannot remove them.

One can postulate that increasing the catalytic oxidizer operating temperature might restore the oxidizer efficiency when halogenated species are present. Even when a catalyst has been irreversibly poisoned by sulfur dioxide, its efficiency for methane conversion could be temporarily restored by operating at an elevated temperature.[3] To our knowledge, increasing oxidizer temperature

to eliminate the effect of reversible halogen poisoning has not been considered to date. While this procedure should not be considered an alternative to good removal of the sulfur- and nitrogen-containing compounds, it may be useful for circumventing irreversible catalyst poisoning during emergencies. In any event, catalytic oxidation of light halogenated hydrocarbon may be the only mechanism for removing those species if they begin to build up in the cabin atmosphere.

REFERENCES

1. T.M. Olcott, "Study and Preliminary Design of an Isotope-Heated Catalytic Oxidizer System," NASA CR-66346.
2. N. Willis, NASA/MSC, Houston, Texas, personal communication, May 1970.
3. T.M. Olcott, "Development and Design of an Isotope-Heated Catalytic Trace Contaminant Control System," NASA CR-66739, February 1969.
4. R.A. Saunders, *Proceedings of the 2nd Annual Conference on Atmospheric Contamination in Confined Spaces, 4 and 5 May 1966*, AMRL-TR-66-120 (December 1966), pp 53-59.
5. N. Nelson (Chairman), "Atmospheric Contaminants in Spacecraft," Report of the Panel on Air Standards for Manned Space Flight, Space Science Board, NAS, NRC, 1968.
6. E.H. Harris, NASA/MSC Houston, personal communication, February 1970.
7. Hamilton-Standard Division of United Aircraft Corporation, "Trade-Off Study and Conceptual Designs of Regenerative Advanced Integrated Life Support Systems (AILSS)," Windsor Locks, Connecticut, Final Report for NASA Contract No. NAS1-7905, July 1969, p 257.
8. W. Rippstein, NASA/MSC, Houston, Texas, personal communication, May 1970.
9. Perkin-Elmer Corp. Aerospace Systems, Pomona, California, NASA CR-66606.
10. W.F. White, "Qualitative Analysis of Gas Mixtures by Microwave Spectroscopy," paper presented at the 155th National ACS meeting, San Francisco, California (March 31-April 5, 1968).
11. J.T. Funkhouser, S. Armstrong, and H.W. Harrington, *Anal. Chem.*, **40**, 22A (1968).
12. B.F. Scribner and M. Margoshes in *Treatise on Analytical Chemistry*, Vol. 6, Part 1 (New York: Interscience, 1965).
13. A.J. McCormack, G.G.C. Tong, and W.D. Cooke, *Anal. Chem.*, **37**, 1470 (1965).

14. C.D. West, *Anal Chem.*, **42**, 811 (1970).
15. G.A. Rechnitz, *Chem. Eng. News*, June 12, 1967, p 146.
16. Anon., *Chem. Eng. News*, March 16, 1970.
17. Whittaker Research and Development, San Diego, California.
18. W.S. Updegrave and P. Haug, *American Laboratory*, **8**, February 1970.
19. Finnigan Instruments Corporation, 2631 Hanover Street, Palo Alto, California.
20. G.A. Shoemake Jet Propulsion Laboratory, Pasadena, California, personal communication, May 1970.
21. R. Hatch, *J. Gas Chromatography*, **6**, 611 (1968).
22. J. Halasz and I. Sebastian, *Angew. Chem.*, **81**, 464 (1969).
23. K. Sakodinsky, *Chromatographia*, **1**, 483 (1968).
24. W.N. Sanders and J.B. Maynard, *Anal. Chem.*, **40**, 527 (1968).
25. J.C. Sternberg, in *Advances in Chromatography*, Vol. 2, J.C. Giddings and R.A. Keller, eds. (New York: Dekker, 1966), pp 205-270.
26. C.A.M.G. Cramers and M.M. van Kessel, *J. Gas Chromatog.*, **6**, 577 (1968).
27. D.E. Willis, *Anal. Chem.*, **40**, 1597 (1968).
28. E.E. Bartel and S.J. van der Walt, *J. Gas Chromatog.*, **6**, 396 (1968).
29. J.E. Lovelock, K.W. Charlton, and P.G. Simmonds, *Anal. Chem.*, **41**, 1049 (1969).
30. J.D. Lem, Jr., *Aerospace Medicine*, November 1967, p 1110.
31. J.T. Watson and K. Biemann, *Anal. Chem.*, **36**, 1135 (1964).
32. S.P. Markey, *Anal. Chem.*, **42**, 306 (1970).
33. P.M. Krueger and J.A. McCloskey, paper 45, *17th Annual Conference on Mass Spectrometry and Allied Topics* (Dallas, Texas, 1969).

34. A.J. Luchte, D.C. Damoth, and C.J. Moorman, paper 44, *17th Annual Conference on Mass Spectrometry and Allied Topics* (Dallas, Texas, 1969).
35. R. Cree, *Pittsburgh Conference on Analytical Chemistry and Applied Spectroscopy* (Pittsburgh, Pennsylvania, March 1967).
36. R. Ryhage, *Anal. Chem.*, **36**, 759 (1964).
37. S.R. Lipsky, C.G. Horvath, and W.J. McMurray, *Anal. Chem.*, **38**, 1585 (1966).
38. P. Llwellyn and D. Littlejohn, *Pittsburgh Conference on Analytical Chemistry and Applied Spectroscopy* (Pittsburgh, Pennsylvania, February 1966).
39. C.A. McDowell, *Mass Spectrometry* (New York: McGraw-Hill, 1963).
40. A.D. Bailey and R.S. Narcisi, AFCRL-66-148, Air Force Cambridge Research Laboratories, Bedford, Massachusetts, Project 6687, February 1966.
41. H.D. Beckey, *Advances in Mass Spectrometry*, Vol. II (Oxford: Pergamon Press, 1963), p 1.
42. H.D. Beckey, H. Knoppel, G. Metzinger, and P. Schulze, Vol. III (Oxford: Pergamon Press, 1963), p 35.
43. P. Bryant, University of Missouri, Columbia, Missouri, NAS12646.
44. M.S.B. Munson and F.H. Field, *J. Am. Chem. Soc.*, **88**, 2621 (1966).
45. *Chem. and Eng. News*, **69**, April 27, 1970.
46. J.R. Roehrig, Norton Research Corporation, Cambridge, Massachusetts NAS1-5347.
47. L. Hall, Perkin-Elmer Corp., Aerospace Systems, Pomona, California, personal communication, May 1970.
48. J. Hoffman, University of Texas, Dallas, Texas, NAS9-10410.
49. Perkin-Elmer Corp., Aerospace Systems, Pomona, California, NAS1-6387.
50. L.R. Carpenter, NASA Flight Research Center, Edwards Air Force Base, California, personal communication, May 1970.

- 
51. A.O. Nier, *Rev. Sci. Instr.* 31, 1127 (1960).
 52. C.E. Giffin, Jet Propulsion Laboratory, Pasadena, California, personal communication, May 1970.
 53. R.A. Hites and K. Biemann, *Anal. Chem.*, 40, 1217 (1968).
 54. B. Knock, D. Wright, W. Kelley, and R.G. Ridley, paper 136, *17th Annual Conference on Mass Spectrometry and Allied Topics* (Dallas, Texas, 1969).
 55. C. Cone, P. Fennessey, R. Hites, N. Mancuso, and K. Biemann, paper 39, *15th Annual Conference on Mass Spectrometry and Allied Topics* (Denver, Colorado, 1967).
 56. J.D. Morrison, paper 17, *17th Annual Conference on Mass Spectrometry and Allied Topics* (Dallas, Texas, 1969).
 57. R.A. Smith, F.E. Jones, and R.P. Chasmar, *Detection and Measurement of Infrared Radiation*, 2nd Ed. (Oxford: Clarendon Press, 1968).
 58. J. H. Davies, *Anal. Chem.*, 42, 101A (1970).
 59. C.B. Ludwig, R. Bartle, and M. Griggs, "Study of Air Pollutant Detection by Remote Sensors," NASA CR-1380, July 1969.
 60. International Union of Pure and Applied Spectroscopy, *Tables of Wavenumbers for the Calibration of Infrared Spectrometers*, (Washington: Butterworths, 1961).
 61. W.F. Herget, W.E. Deeds, N.M. Gailar, R.J. Lovell, and A.H. Nielson, *J. Opt. Soc. Am.*, 52, 1113 (1962).
 62. A.H. Nielsen, T.G. Burke, P.J.H. Woltz, and E.A. Jones, *J. Chem. Phys.*, 20, 596 (1952).
 63. A.H. Nielsen, *J. Chem. Phys.*, 19, 98 (1951).
 64. R.H. Pierson, A.N. Fletcher, and E. St. Clair Gantz, *Anal. Chem.*, 28, 1218 (1956).
 65. R.D. Shelton, A.H. Nielsen, and W.H. Fletcher, *J. Chem. Phys.*, 21, 2178 (1953).

66. F.L. Keller and A.H. Nielsen, *J. Chem. Phys.*, 24, 636 (1956).
67. G.E. Moore, *J. Opt. Soc. Am.*, 43, 1045 (1953).
68. *The Sadtler Standard Spectra*, Sadtler Research Laboratories, Philadelphia, Pennsylvania, spectrum 5963.
69. H.H. Blau, "The Infrared Absorption Spectrum of Formaldehyde Vapor," Ph.D. thesis, Ohio State University, 1955.
70. P.A. Giguere and J.D. Liu, *J. Chem. Phys.*, 20, 136 (1952).
71. W.S. Richardson and J.H. Goldstein, *J. Chem. Phys.*, 18, 1314 (1950).
72. D.S. Erley and B.H. Blake, *Infrared Spectra of Gases and Vapors*, Vol. 1, Dow Chemical Co., Midland, Michigan, 1964.
73. "Flight Packaged Onboard Checkout System Development Unit," Martin Marietta Corp., Report, NAS9-8000, June 11, 1969.

Please leave this
for a protected cover
for Bach