

SPACE SHUTTLE HIGH PRESSURE AUXILIARY PROPULSION SYSTEM

H. L. Burge and J. Cuffe
TRW Systems Group
Redondo Beach, California

and A. Shaffer
Airesearch Manufacturing Company
Los Angeles, California

ABSTRACT

THE REQUIREMENTS FOR A HIGH PRESSURE SSAPS ARE REVIEWED. FOR A DEFINED VEHICLE AND MISSION, THESE ARE DETERMINED BY THE PRIMARY PROPULSION SYSTEM CAPABILITY. SOME OF THE FUNDAMENTAL SYSTEM PROBLEMS ARE DISCUSSED AND THE INFLUENCE OF APS ΔV REQUIREMENTS UPON THE SYSTEM PERFORMANCE SENSITIVITY IS DETERMINED. THE MAIN ELEMENTS OF A HIGH PRESSURE APS ARE DEFINED. TECHNOLOGY EFFORTS ARE DIVIDED INTO THREE OVERLAPPING AND INTERACTING ACTIVITIES, NAMELY FUNDAMENTAL LIMITS, APPLICATION LIMITS AND PREDEVELOPMENT ACTIVITIES. TO ILLUSTRATE SOME OF THE PROBLEMS DISCUSSED IN THIS PAPER, A CANDIDATE HIGH PRESSURE APS FOR HIGH ΔV APPLICATIONS IS PRESENTED AND DISCUSSED.

GENERAL REQUIREMENTS

THE AUXILIARY PROPULSION SYSTEM (APS) WILL BE REQUIRED TO FUNCTION FOR A MINIMUM SERVICE LIFE OF 100 MISSION CYCLES OVER EIGHT (8) YEARS PRIOR TO MAJOR OVERHAUL/REFURBISHMENT AND WITH ONLY MINOR SERVICING ALLOWED BETWEEN EACH MISSION. DESIGN REQUIREMENTS FOR THE APS INCLUDE LONG LIFE, HIGH RELIABILITY, REUSABILITY, MINIMAL AND EASY SYSTEM MAINTENANCE AND REFURBISHMENT, ONBOARD SYSTEMS STATUS/CHECKOUT/FAILURE DETECTION AND ISOLATION SYSTEM, HIGH PERFORMANCE, MINIMUM COMPLEXITY, AND MINIMUM WEIGHT. IN ADDITION, THE SYSTEM MUST HAVE THE CAPABILITY TO REMAIN OPERATIONAL WITH A SINGLE FAILURE AND WITH A SECOND FAILURE TO ASSUME A FAIL-SAFE CONDITION FOR CREW SURVIVAL.

FURTHERMORE, THE APS MUST HAVE THE FLEXIBILITY NECESSARY TO BE ABLE TO ACCOMMODATE MISSION CHANGES AND IT IS DESIRABLE THAT IT SHOULD REQUIRE A MINIMUM OF NEW TECHNOLOGY.

GENERAL REQUIREMENTS

HIGH DELIVERED PERFORMANCE

RELIABILITY

MAINTAINABILITY

LONG LIFE

SAFETY

MISSION FLEXIBILITY

MINIMIZE CRITICAL TECHNOLOGY

APS ELEMENTS

THE AUXILIARY PROPULSION SYSTEM WILL UTILIZE THE SAME TYPE PROPELLANTS AS THE VEHICLE MAIN PROPULSION; I.E., OXYGEN AND HYDROGEN, TO TAKE ADVANTAGE IN INHERENT HIGH PERFORMANCE, NON-TOXIC AND NON-CORROSIVE PROPERTIES, CLEAN EXHAUST PRODUCTS AND SIMPLIFIED VEHICLE PROPELLANT LOGISTICS. BECAUSE OF THE DIFFICULTY OF DELIVERING THE CRYOGENIC LIQUIDS OVER LONG DISTANCES, THE APS THRUSTORS WILL OPERATE WITH GASEOUS OXYGEN AND HYDROGEN. THE PROPELLANTS HOWEVER, MAY BE STORED IN GASEOUS OR LIQUID FORM, AND THE APS PROPELLANT STORAGE MAY BE INDEPENDENT OF THE MAIN VEHICLE PROPULSION TANKAGE, OR PARTIALLY OR WHOLLY INTEGRATED WITH IT. POTENTIAL BENEFITS MAY BE REALIZED FROM UTILIZING VEHICLE MAIN PROPULSION TANK RESIDUALS IN THE APS.

THE APS CONSISTS OF THE FOLLOWING ASSEMBLIES:

- PROPELLANT STORAGE ASSEMBLY
- PROPELLANT DISTRIBUTION ASSEMBLY
- PROPELLANT CONDITIONING ASSEMBLY
- THRUSTORS

APS ELEMENTS

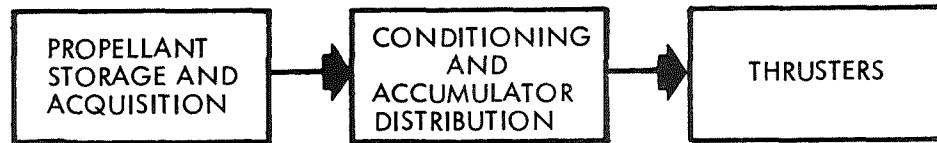

ACQUISITION/ORIENTATION

TURBOMACHINERY (PUMPS/COMPRESSORS)

TANKAGE

HEAT EXCHANGERS

CONTROLS

STATUS INSTRUMENTATION

GAS GENERATORS

THRUSTERS

VALVES

CONTROLS

INSTRUMENTATION

DISTRIBUTION NETWORK

VEHICLE INFLUENCED APS CHARACTERISTICS

BOOSTER

THE BOOSTER APS HAS TO CONTROL THE EMPTY STAGE FROM SEPARATION UNTIL REENTRY INTO THE ATMOSPHERE, WHERE THE AERODYNAMIC CONTROLS BECOME EFFECTIVE. THE ACTUAL SEPARATION MANEUVER OF THE BOOSTER AND ORBITER IS NOT CARRIED OUT BY THE APS. THE APS DUTY CYCLE IS OF SHORT DURATION (UP TO 6 MINUTES), LOW TOTAL IMPULSE, AND ESSENTIALLY THE SAME ON EACH MISSION. THE PROPELLANT REQUIRED BY THE APS REPRESENTS ONLY SOME 10 PERCENT OF MAIN TANK RESIDUALS. THE PERFORMANCE SENSITIVITY OF THE BOOSTER APS IS LOW, SO HIGH SPECIFIC IMPULSE IS NOT OF PRIME IMPORTANCE.

ORBITER

THE ORBITER MUST HAVE THE CAPABILITY TO ACCOMMODATE A VARIETY OF MISSIONS WITH POSSIBLE EXTENDED ON-ORBIT STAY TIME. SYSTEM FLEXIBILITY IS THEREFORE OF PRIME IMPORTANCE, AND ON EXTENDED MISSIONS, THESE SYSTEMS MUST BE CAPABLE OF UTILIZING PROPELLANTS CARRIED IN THE VEHICLE'S PAYLOAD BYA. THE ON-ORBIT ΔV REQUIREMENTS FOR THE APS ARE NOT PRESENTLY DEFINED AND THIS PARAMETER STRONGLY INFLUENCES THE REQUIRED CHARACTERISTICS OF THE APS.

VEHICLE INFLUENCED APS CHARACTERISTICS

BOOSTER

LOW TOTAL IMPULSE
LOW PERFORMANCE SENSITIVITY
SHORT TIME OF OPERATION
LARGER QUANTITY OF RESIDUALS
LOW PEAK FLOW RATES
(SEPARATION MANEUVER EXCEPTED)

ORBITER

INCREASING DELTA-V REQUIREMENTS

INCREASE IN TOTAL IMPULSE
INCREASE IN PERFORMANCE SENSITIVITY
INCREASE IN RANGE OF THRUSTER T. I. REQUIREMENT
STATIONKEEPING (M.I.B.)
EXTENDED TIME OF OPERATION
REDUCTION OF PERCENT OF RESIDUALS

PAYLOAD/APS SPECIFIC IMPULSE SENSITIVITY

THESE VEHICLES ARE TYPICAL OF THE DESIGNS BEING CONSIDERED IN THE PHASE B STUDIES. VEHICLE A IS OF LOW CROSS-RANGE CONFIGURATION, VEHICLE B OF HIGH. FOR VEHICLE A, THE PAYLOAD IS ASSUMED TO HAVE BEEN LEFT IN ORBIT, WHEREAS FOR VEHICLE B, A CONSTANT PAYLOAD UP AND DOWN HAS BEEN ASSUMED.

NOTE THAT WHEREAS FOR AN APS ΔV REQUIREMENT OF 150 TO 200 FT/SEC, $\frac{\partial \text{PAYLOAD}}{\partial I_{SP}}$ COEFFICIENT IS LOW, APPROXIMATELY 10 LB/SEC OR LESS, FOR AN APS WITH A ΔV REQUIREMENT OF 2000 TO 2200 FT/SEC, THIS COEFFICIENT IS INCREASED BY AN ORDER OF MAGNITUDE. IN THIS CASE, OVERALL APS PERFORMANCE IS OF GREAT IMPORTANCE.

APS ΔV REQUIREMENTS

THE ΔV REQUIREMENTS FOR THE ORBITER APS, FOR A GIVEN MISSION, ARE LARGELY DETERMINED BY THE MAIN ENGINE CHARACTERISTICS, WHICH ARE NOT PRESENTLY DEFINED, AND UPON WHETHER AN ON-ORBIT MANEUVERING PROPULSION SYSTEM IS USED OR NOT. HENCE, THERE ARE BASICALLY THREE DIFFERENT RANGES OF APS ΔV REQUIREMENTS TO BE CONSIDERED FOR THE SPACE STATION RESUPPLY DESIGN MISSION.

ALL MANEUVERS ON ALL AXES
(HIGH DELTA-V)

MAIN ENGINE WITH NO RESTART CAPABILITY
(DESIGN CASE)

ALL MANEUVERS ON ALL AXES
EXCEPT + X AXES OF >50 FT/
SEC (INTERMEDIATE DELTA-V)

RESTARTABLE MAIN ENGINE, THROTTLED IN
PUMP FED MODE OR SEPARATE ON ORBIT PRO-
PULSION SYSTEM

ALL MANEUVERING ON ALL AXES
EXCEPT + X AXIS OF >10 FT/
SEC (LOW DELTA-V)

RESTARTABLE MAIN ENGINE, WHICH CAN OPERATE
IN THROTTLED AND PRESSURE FED IDLE MODES,
OR A SEPARATE VARIABLE THRUST ON ORBIT PRO-
PULSION SYSTEM

PERFORMANCE CRITICALITY HAS BEEN SHOWN TO BE A FUNCTION OF THE ΔV REQUIREMENT AND IS VERY IMPORTANT ON THE HIGH ΔV SYSTEM. PROPELLANT CONDITIONING PENALTIES ARE PARTICULARLY IMPORTANT HERE. AN INDICATION OF THE MAGNITUDE OF THESE PENALTIES IS SHOWN.

APS ΔV REQUIREMENTS

APS

ALL MANEUVERS

ALL MANEUVERS EXCEPT
+ X AXIS > 50 FT/SEC

ALL MANEUVERS EXCEPT
+ X AXIS > 10 FT/SEC

PRIMARY PROPULSION

NO RESTART

THROTTLED AND RESTART
OR O.M.S.

IDLE MODE, THROTTLED, MULTIPLE
RESTART OR THROTTLED O.M.S.

APS ΔV FT/SEC

~ 2000 - 2200

~ 400 - 600

~ 150 - 200

198

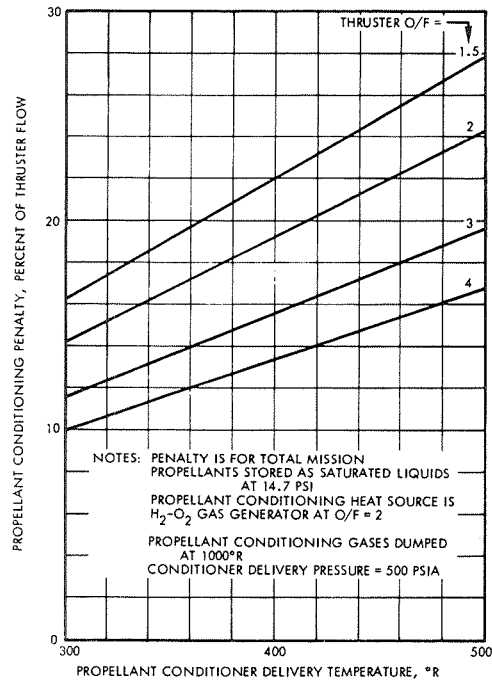

ORBITER

THRUSTER ISP = 420 SEC

1800 FT/SEC $\frac{\delta P.L.}{\delta I_{SP}} = 72 \text{ LB/SEC } I_{SP}$

AT 20% LOSS $\Delta P.L. = 420 \times \frac{20}{100} \times 72$
= 6000 LB

BOOSTER EFFECT. $\approx -5 \text{ LB BOOSTER P. L. / SEC } I_{SP}$

APS PROPELLANT REQUIREMENTS

THESE VEHICLES ARE TYPICAL OF THE DESIGNS BEING CONSIDERED IN THE PHASE B STUDIES. VEHICLE A IS OF LOW CROSS-RANGE CONFIGURATION, VEHICLE B OF HIGH. FOR VEHICLE A, THE PAYLOAD IS ASSUMED TO HAVE BEEN LEFT IN ORBIT, WHEREAS FOR VEHICLE B, A CONSTANT PAYLOAD UP AND DOWN HAS BEEN ASSUMED.

ORBITER

NOTE THAT FOR AN ORBIT ΔV 'S FOR 2000 - 2200 FT/SEC, THE APS PROPELLANT REQUIRED APPROACHES THAT OF THE PAYLOAD MASS. HENCE, ASSUMING NO IN ORBIT REFUELING; THEN, EVEN WITH NO PAYLOAD, IT IS DOUBTFUL IF THE 5000 FT/SEC V REQUIREMENT FOR THE 800 N.M. ORBIT CAN BE MET.

BOOSTER

THE APS ΔV REQUIREMENT, ASSUMING NO SEPARATION MANEUVER, IS <30 FT/SEC. THE PROPELLANT REQUIRED, EVEN WITH A SYSTEM OF LOW I_{SP} , IS LESS THAN ONE-THIRD PERCENT OF THE EMPTY VEHICLE MASS AT STAGING.

DESIGN WEIGHING FACTORS

BOOSTER

WITH ITS LOW PERFORMANCE SENSITIVITY AND MISSION FLEXIBILITY REQUIREMENTS, THE DESIGN EMPHASIS IS FOR A SIMPLE AND RELIABLE SYSTEM, AT MINIMUM COST AND UTILIZING A MINIMUM OF NEW TECHNOLOGY.

ORBITER

THE PERFORMANCE WEIGHING FACTOR (SYSTEM WEIGHT, WHICH IS A COMBINATION OF INERT AND PROPELLANT WEIGHTS) IS STRONGLY DEPENDENT UPON THE ΔV REQUIREMENT. WHEREAS RELIABILITY AND FLEXIBILITY CANNOT BE COMPRISED, HIGH PERFORMANCE FOR THE HIGH ΔV APPLICATIONS HAS TO BE OBTAINED, EVEN IF THIS RESULTS IN A MORE COMPLICATED SYSTEM REQUIRING THE APPLICATION OF NEW TECHNOLOGY.

DESIGN WEIGHTING FACTOR CONSIDERATIONS

	BOOSTER		ORBITER	
	LO ΔV	LO ΔV	INTER ΔV	HIGH ΔV
	~ 25 - 30 FPS	~ 150 - 200 FPS	~ 400 - 600 FPS	~ 2000 - 2200 FPS
SYSTEM WEIGHT	LOW	INTER.	INTER.	HIGH
RELIABILITY	HIGH	HIGH	HIGH	HIGH
FLEXIBILITY	LOW	HIGH	HIGH	HIGH
SIMPLICITY	HIGH	HIGH	INTER.	LOW
MIN. NEW TECHNOLOGY	HIGH	INTER.	INTER.	LOW
COST	HIGH	INTER.	INTER.	INTER.

CANDIDATE CYCLES

THREE GENERAL CLASSES OF SYSTEMS MAY BE CONSIDERED:

1. GASES STORED AT HIGH PRESSURE AND AT TEMPERATURES ACCEPTABLE TO THE THRUSTER INLET REQUIREMENTS. HIGH PRESSURE GAS STORAGE SYSTEMS ARE SIMPLE, BUT THEY MAY NOT BE SELECTED, EVEN FOR USE IN THE BOOSTER, BECAUSE OF THEIR EXCESSIVE WEIGHT PENALTY.
2. LIQUIDS STORED AT HIGH PRESSURE HEATED TO ACCEPTABLE THRUSTER INLET CONDITIONS. HIGH PRESSURE SUPERCRITICAL STORAGE ARRANGEMENTS REQUIRE SEPARATE APS STORAGE AND COULD POTENTIALLY ELIMINATE THE USE OF ACCUMULATORS; THIS WOULD PROBABLY NOT BE TRUE IN PRACTICE BECAUSE OF THRUSTER RESPONSE REQUIREMENTS AND THE SIZABLE LINE LENGTHS REQUIRED IN SHUTTLE. THE CONCEPT OFFERS HIGH SYSTEM RELIABILITY, LOW DEVELOPMENT COST, AND CAN SUPPLY PROPELLANT INDEPENDENT OF THE GRAVITY FIELD OR VEHICLE ATTITUDE.
3. LIQUID OR GAS AT LOW TEMPERATURE AND PRESSURE COMPRESSED (PUMPED) AND HEATED TO ACCEPTABLE THRUSTER INLET CONDITIONS.

CANDIDATE CYCLES

THREE GENERAL CLASSES

I STORED HIGH PRESSURE GAS

- o SEPARATE TANKAGE - HIGH WEIGHT PENALTY

II LIQUIDS STORED AT HIGH PRESSURE

- o SUPER CRITICAL STORAGE
- o REQUIRE SEPARATE STORAGE
- o CONTROLLED HEAT INPUT
- o POSSIBLE MAKEUP REQUIREMENT
- o GAS GENERATOR/ VENTING
- o HEAT EXCHANGER OPERATION

III LOW PRESSURE STORED GAS/LIQUID

PUMPED/HEATED

COMPRESSED

- o REQUIRES HIGH TEMPERATURE ACCUMULATORS FOR TIME CONSTANTS
- o PROPELLANT ACQUISITION
- o GAS GENERATOR/VENTING
- o HEAT EXCHANGER OPERATION
- o TEMPERATURE ? POWER FOR GAS

TURBOCOMPRESSOR CONCEPT

CYCLES USING TURBOCOMPRESSORS POTENTIALLY PERMIT BOOST TANK RESIDUAL VAPOR TO BE USED AT NO PENALTY TO THE APS. COMPRESSOR PRESSURE RATIOS ATTAINABLE WITH REASONABLE MACHINERY LEAD TO RELATIVELY LOW GAS ACCUMULATOR PRESSURES AND THUS BULKY AND HEAVY ACCUMULATORS. COMPRESSOR POWER AND ACCUMULATOR WEIGHTS ARE PARTICULARLY SENSITIVE TO INLET GAS TEMPERATURE AND BECOME EXCESSIVE AS THESE APPROACH ROOM TEMPERATURE.

TURBOPUMP CONCEPT

TURBOPUMPING CYCLES OFFER HIGH PERFORMANCE AND HIGH FLOW CAPABILITIES AND THUS WILL RECEIVE HEAVY EMPHASIS IN THE PROPOSED STUDY. THEY UTILIZE PROPELLANTS STORED AS LOW PRESSURE LIQUIDS AND THUS PERMIT LOW STORAGE PENALTIES. HOWEVER, FOR SPACE SHUTTLE APS APPLICATIONS, THE FEED SYSTEMS HAVE TO BE ABLE TO SUPPLY LIQUID TO THE PUMP UNDER ZERO G CONDITIONS OR WITH AN ACCELERATION VECTOR IN ANY DIRECTION. HIGH DELIVERY PRESSURES ARE RELATIVELY EASILY ACCOMPLISHED, PERMITTING THE USE OF COMPACT ACCUMULATORS TO HANDLE TRANSIENT DEMANDS.

"CONDITIONER" = PRESSURE CONDITIONING AND TEMPERATURE CONDITIONING

SOME CANDIDATE PRESSURE CONDITIONING METHODS

205

	<u>POTENTIAL APPLICATIONS</u>			
	<u>BOOSTER</u>	<u>HI DELTA-V</u>	<u>INTER. DELTA-V</u>	<u>LO DELTA-V</u>
HIGH PRESSURE STORED GAS				
○ MONOPROPELLANT	X			
○ BIPROPELLANT	X			
HIGH PRESSURE CRYOGENIC				
○ PRE-CHARGED	X		X	X
○ TAP FROM TURBOPUMP ENGINE	X		X	X
TURBO COMPRESSOR	X			
PUMP				
○ HIGH TEMPERATURE, HIGH PRESSURE TURBINE		X	X	X
○ LOW TEMPERATURE, LOW PRESSURE TURBINE		X	X	X
○ ELECTRICAL		X	X	X

CANDIDATE SUPERCRITICAL STORAGE CYCLE

THE CHART SHOWS A BASIC HIGH PRESSURE, HIGH DENSITY STORAGE SYSTEM WHICH PROVIDES FOR PROPELLANT PRESSURIZATION WITHOUT TURBOMACHINERY OR PROPELLANT ACQUISITION PROVISIONS. HERE THE PROPELLANTS ARE STORED AT CRYOGENIC TEMPERATURES AND PRESSURES HIGHER THAN CRITICAL AND HIGHER THAN THRUSTER REQUIREMENTS. AS PROPELLANTS ARE WITHDRAWN FROM STORAGE, HEAT IS ADDED TO MAINTAIN STORAGE TANK PRESSURE; ADDITIONAL ENERGY IS ADDED TO EACH PROPELLANT BEFORE DELIVERY TO THE THRUSTERS. THE HIGH PRESSURE CRYOGENIC STORAGE CONCEPT OFFERS SYSTEM SIMPLICITY AND A SOLUTION TO ZERO G SUPPLY PROBLEMS AT THE EXPENSE OF INCREASED STORAGE TANK WEIGHTS AND A POTENTIALLY HIGH PROPELLANT CONDITIONING PENALTY (RELATIVE TO THE TURBO-MACHINERY CONCEPT). IT IS THUS MOST APPLICABLE IN CASES WHERE APS EFFICIENCY IS NOT CRITICAL. AS IN THE TURBOPUMP CYCLE, A CLOSED HELIUM LOOP IS USED FOR TANK PRESSURIZATION AND FLUID HEATING; THE CYCLE HEAT SOURCE IS A GAS GENERATOR OPERATING ON A PORTION OF THE PROPELLANTS. OXYGEN TANK PRESSURIZATION IS ACHIEVED BY PASSING THE HEATED HELIUM THROUGH A HEAT EXCHANGER LOCATED IN THE TANK. A FAN IS LOCATED IN THE TANK TO PROVIDE CIRCULATION AND A HIGH HEAT TRANSFER COEFFICIENT. HYDROGEN TANK PRESSURIZATION IS ACCOMPLISHED INDIRECTLY; HERE FLUID IS WITHDRAWN FROM THE TANK, COMPRESSED, HEATED BY HELIUM, AND READMITTED TO THE TANK.

CANDIDATE SUPERCRITICAL STORAGE CYCLE

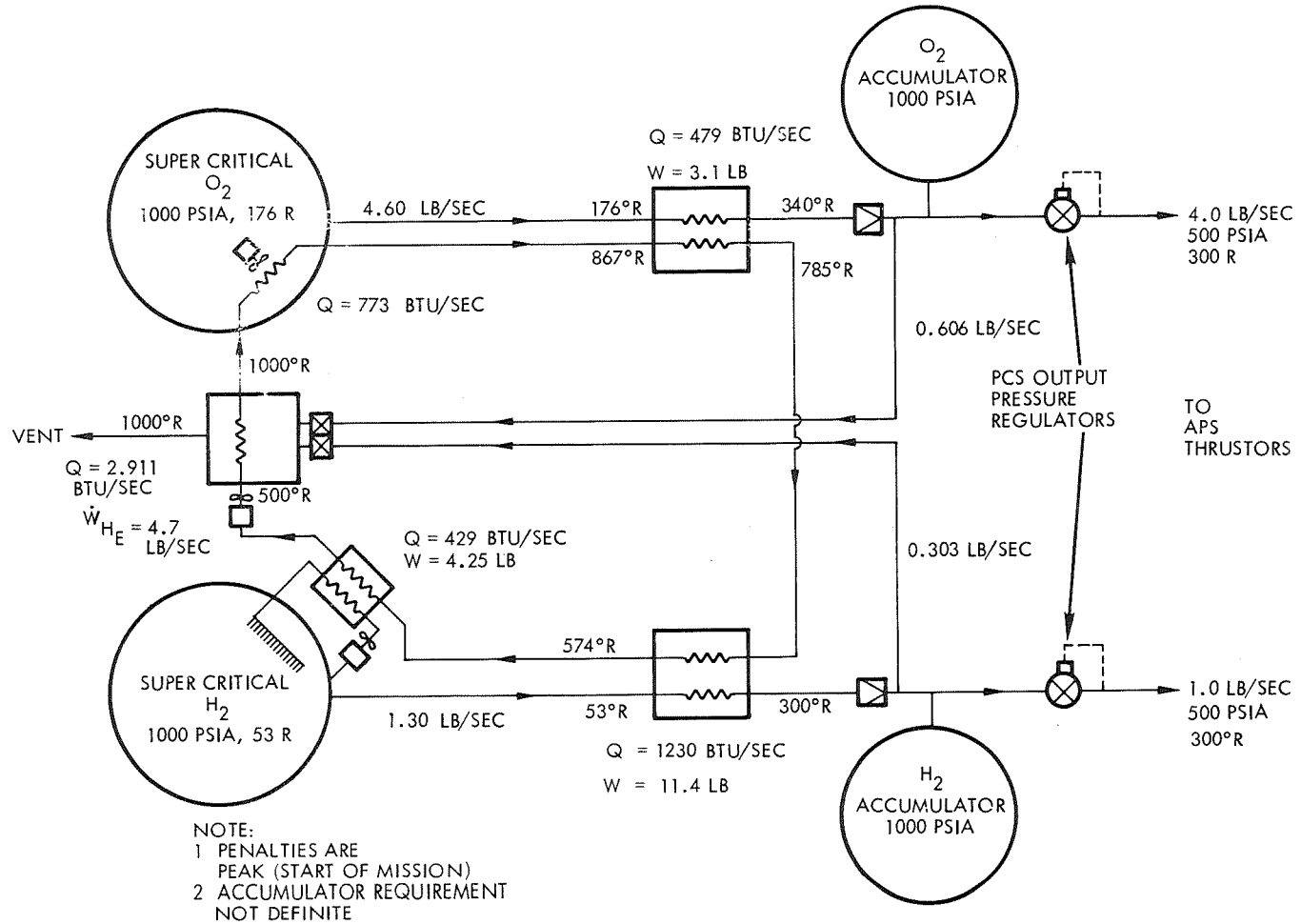

CANDIDATE TURBOPUMP CYCLE

THE CHART IS A SIMPLIFIED SCHEMATIC OF A TURBOPUMP CYCLE SHOWING MAJOR SYSTEM COMPONENTS AND STEADY-STATE OPERATING CONDITIONS FOR A THRUSTER HYDROGEN FLOW OF 1 LB/SEC, A THRUST O/F OF 4, A PCS DELIVERY PRESSURE OF 1500 PSIA AND A DELIVERY TEMPERATURE OF 300°R. A CENTRAL GAS GENERATOR BURNING HYDROGEN AND OXYGEN PROVIDES HOT GAS FOR THE TURBOPUMP TURBINES AND THERMAL ENERGY (THROUGH A CLOSED HELIUM LOOP) FOR HEATING THE PROPELLANTS TO STORAGE ACCUMULATOR TEMPERATURES.

CANDIDATE TURBOPUMP CYCLE

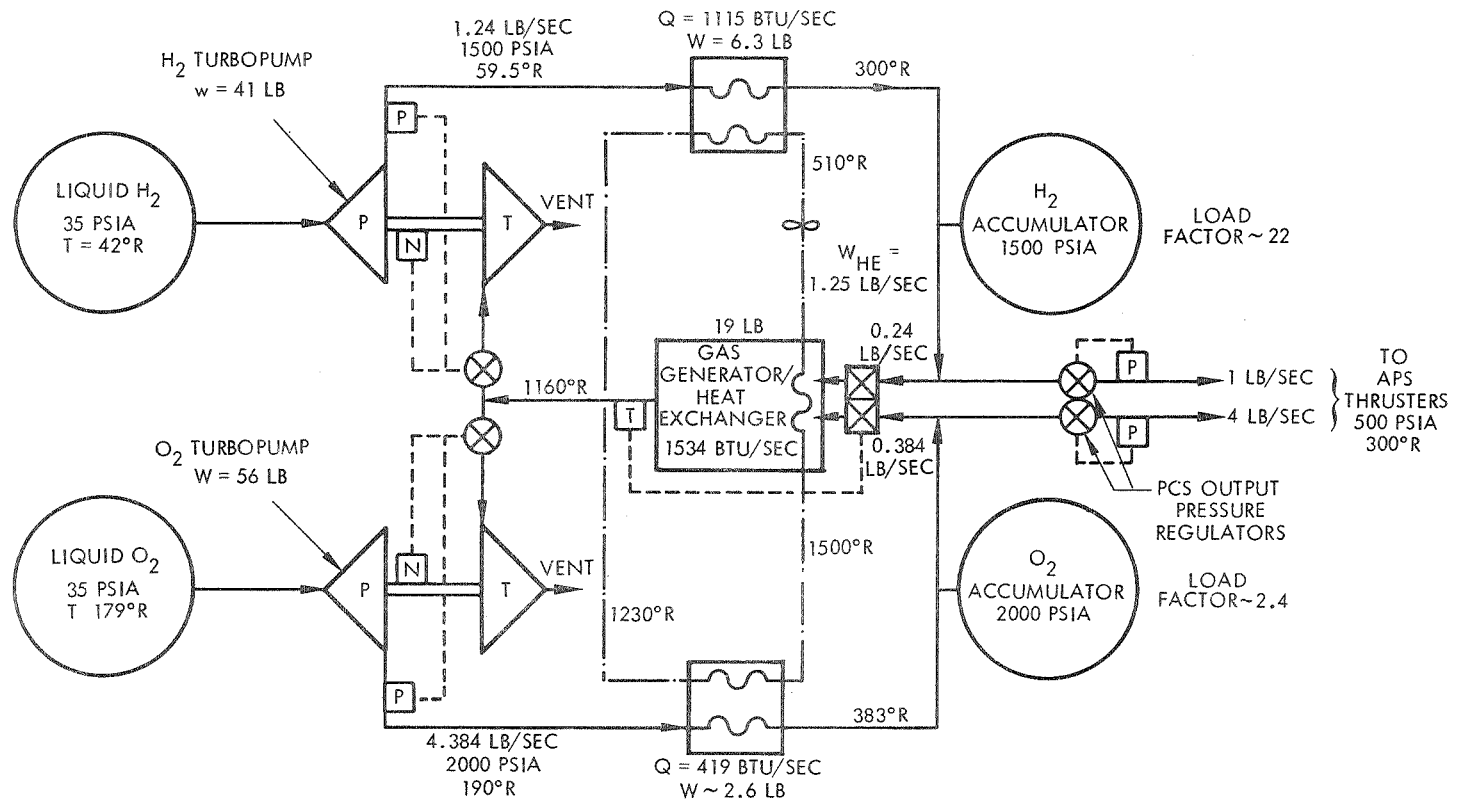

TURBOPROP PROPELLANT CONDITIONING PENALTY

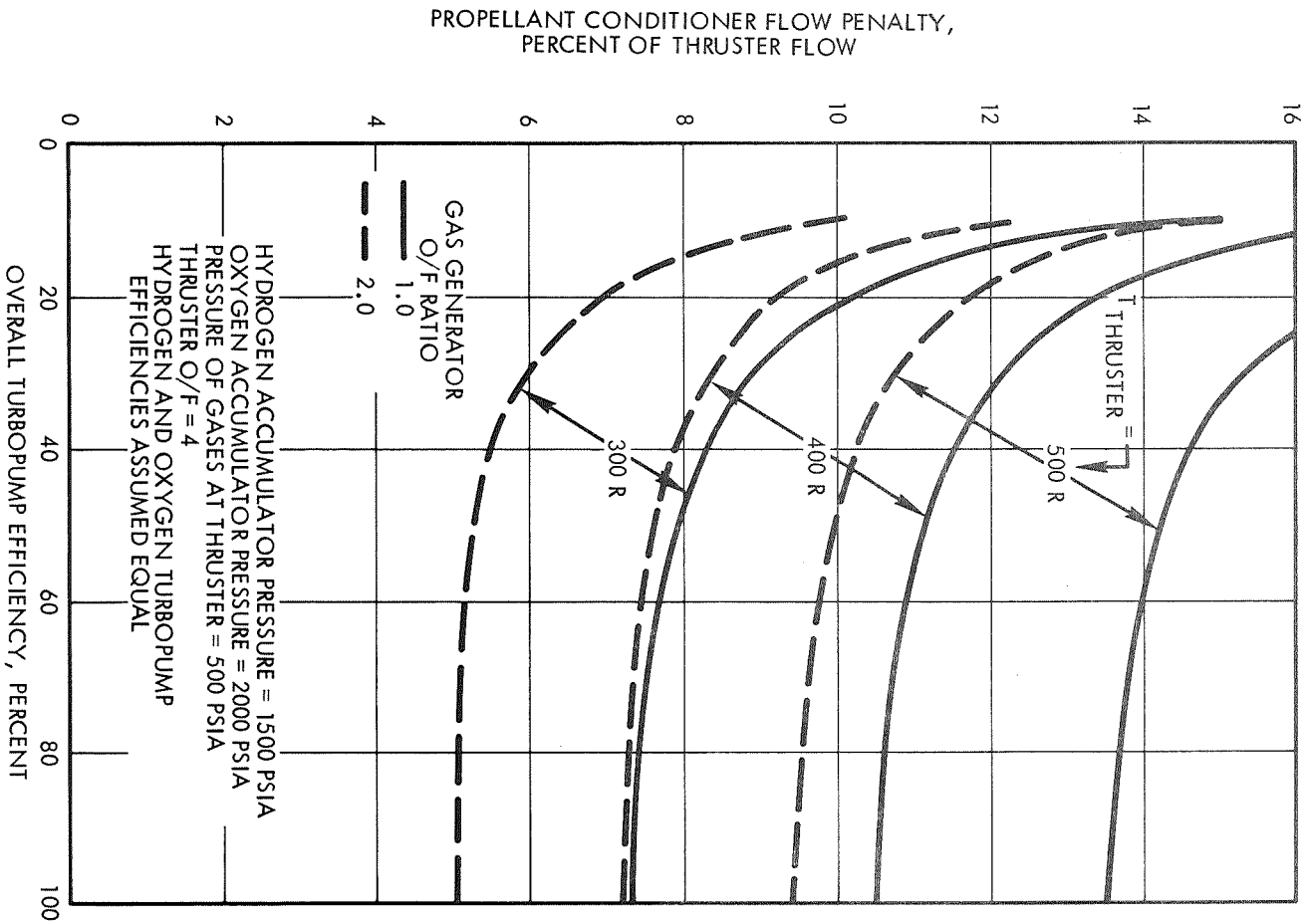

TURBOPUMP CONDITIONER WEIGHT FACTORS

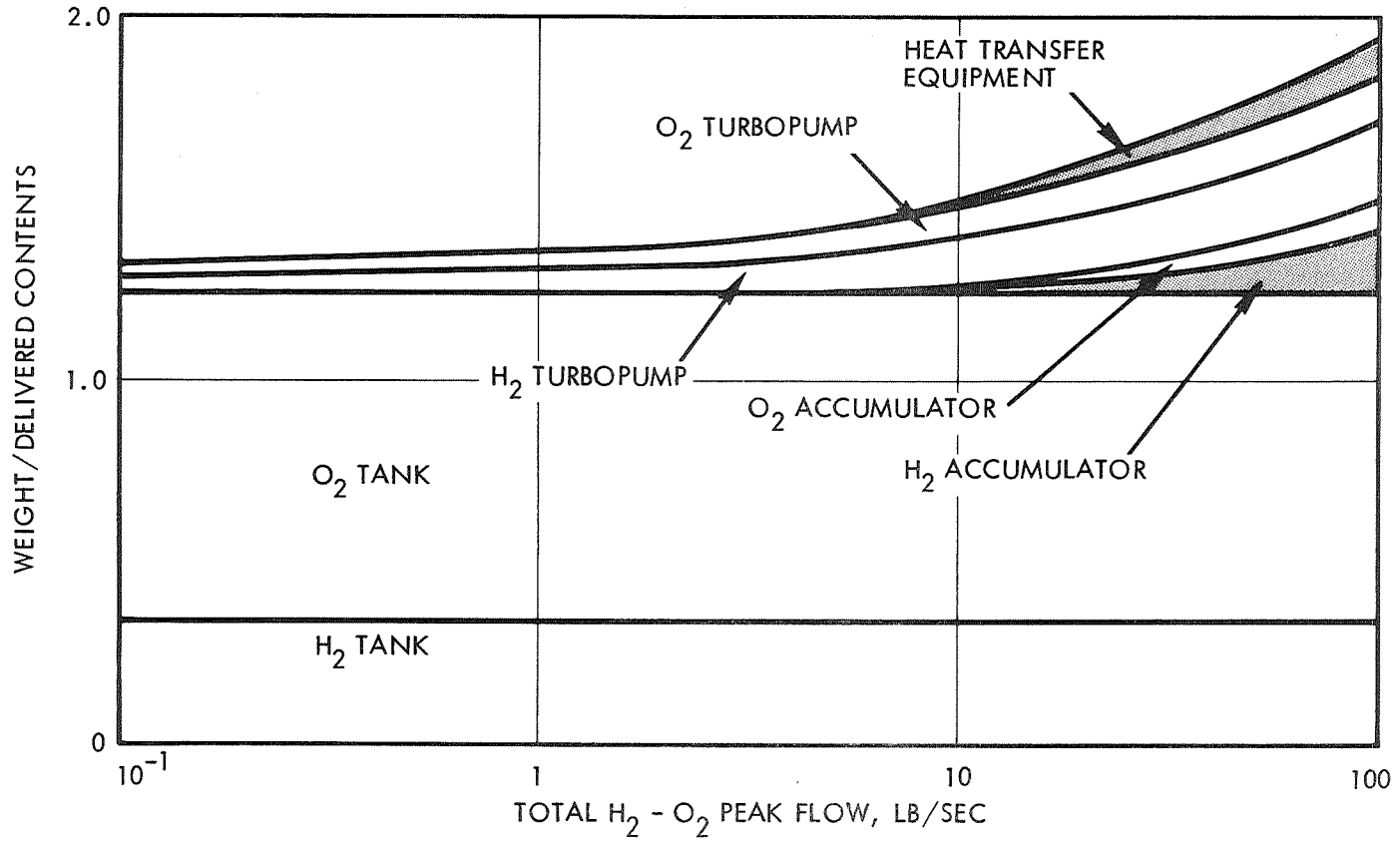

HEAT EXCHANGER WEIGHTS AND VOLUMES

IN THE POWER CONDITIONING CYCLES CONSIDERED, THE HIGH FLUID DENSITIES AND HIGH TEMPERATURE DIFFERENCES AVAILABLE FOR HEAT TRANSFER LEAD TO MODEST HEAT EXCHANGER WEIGHTS AND VOLUMES EVEN AT THE HIGH OPERATING PRESSURES. AT A THRUSTER O/F OF 4, THE HELIUM-TO-HYDROGEN HEAT EXCHANGER, FOR EXAMPLE, WILL WEIGH LESS THAN 10 POUNDS AT A HYDROGEN FLOW OF 1 POUND PER SECOND. AT A FLOW RATE OF 10 LB/SEC AND A THRUSTER INLET TEMPERATURE OF 300°R, THIS HEAT EXCHANGER WILL WEIGH BETWEEN 20 AND 40 POUNDS FOR PRESSURES UP TO 3000 PSIA. THESE WEIGHTS WILL BE APPROXIMATELY TRIPLED FOR A THRUSTER INLET TEMPERATURE OF 500°R. THE HELIUM-TO-OXYGEN HEAT EXCHANGERS HAVE MUCH LOWER REQUIREMENTS AND HAVE ESTIMATED WEIGHTS ONE-HALF TO ONE-THIRD THOSE OF THE HYDROGEN HEAT EXCHANGERS. IF THE PROPELLANTS WERE TO BE HEATED DIRECTLY BY COMBUSTION PRODUCTS, THESE WEIGHTS WOULD BE CONSIDERABLY GREATER BECAUSE OF THE PROVISIONS REQUIRED TO MINIMIZE THE FREEZING PROBLEM. THIS IS PARTICULARLY TRUE FOR THE OXYGEN HEAT EXCHANGER.

HEAT EXCHANGERS

HEAT EXCHANGERS INTEGRAL PART OF ALL SYSTEMS UNDER CONSIDERATION

BASIC SYSTEMS: INERT GAS THERMAL TRANSFER LOOP
 DIRECT G G EXCHANGE
 ENVIRONMENT CONDUCTION/CONVECTION

PROBLEM: WIDELY VARYING PROPERTIES
 ZERO LEAKAGE ALLOWABLE
 MINIMUM WEIGHT, ΔP

H₂ TO He - HIGH h, P ⇒ TUBULAR ALL PRIME SURFACE

O₂ TO He - LOWER h ⇒ MAY NEED EXTENDED SURFACE

COMBUSTION TO He - REQUIRES THERMAL CONTROL

WEIGHTS - MODEST WEIGHTS/VOLUMES

EX - He/H₂ \dot{W} (O/F = 4) = 1 LB/SEC, W < 10 LB
 W = 10 LB/SEC, W ~ 40 LB
 T = 300°F

DISTRIBUTION

RELATIVELY LARGE DISTRIBUTION LOOP WITH LARGE MOMENT ARMS

- IMPOSES REQUIREMENT FOR CLOSE P, T CONTROL

CONSIDERATIONS

- DUCT SIZING
- LOOP CHOICE, T OR CIRCULATORY
- ACCUMULATOR SIZING/ PLACEMENT
- THERMAL/STRUCTURAL
- ACCESSIBILITY/MAINTAINABILITY
- LEAKAGE/DETECTION
- FLOW RATE/MIXTURE RATIO

SPACE SHUTTLE APS- RANDOM ENGINE FIRING

PROPELLANT LINES = 1.0 IN. DIA., 100 FT. LONG
ACCUMULATORS: FUEL = FT^3 ; OX = FT^3

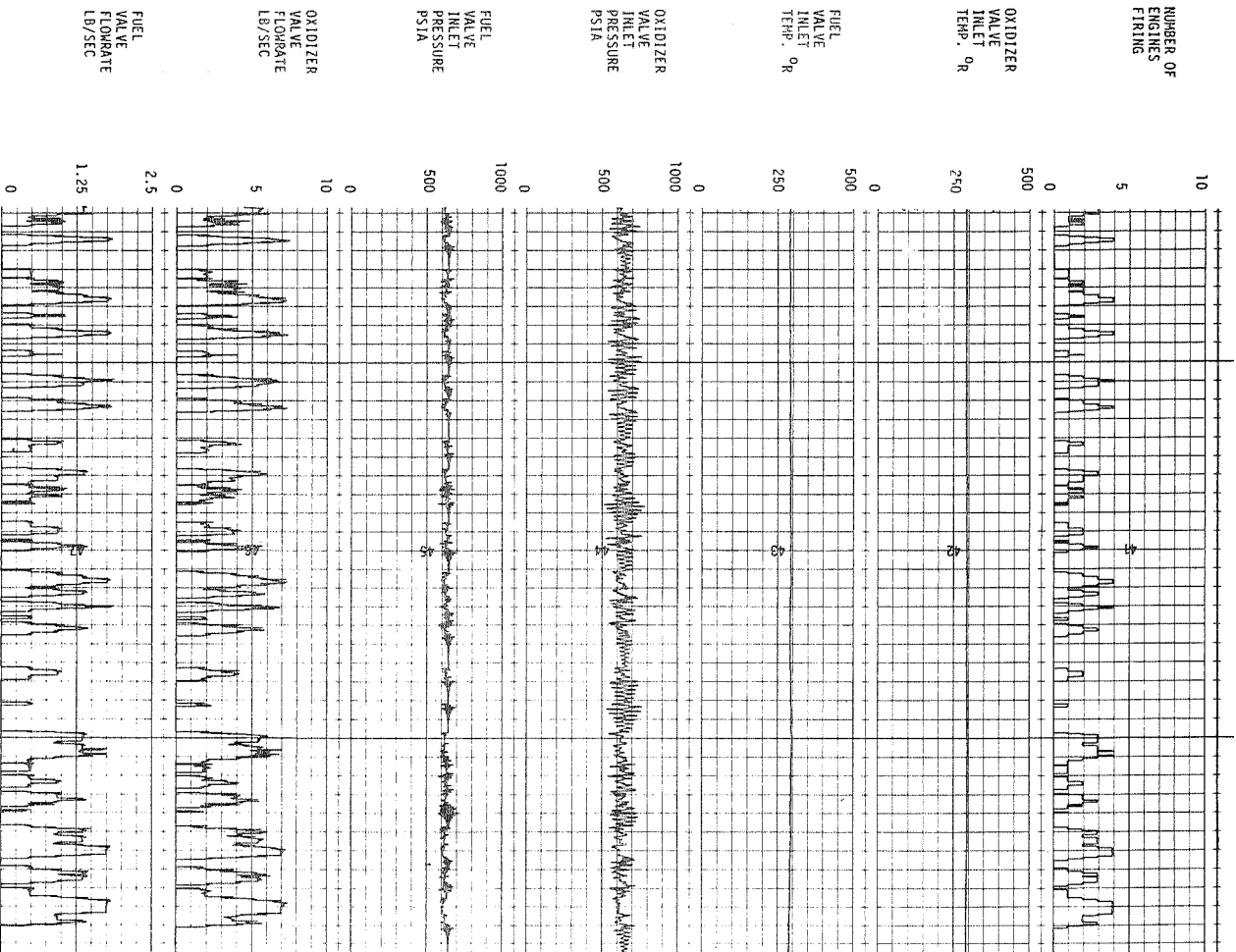

SPACE SHUTTLE APS - RANDOM ENGINE FIRING

PROPELLANT LINES = 2 1/2 IN. DIA., 100 FT. LONG
ACCUMULATORS: FUEL = 50 FT³; OX = 12.5 FT³

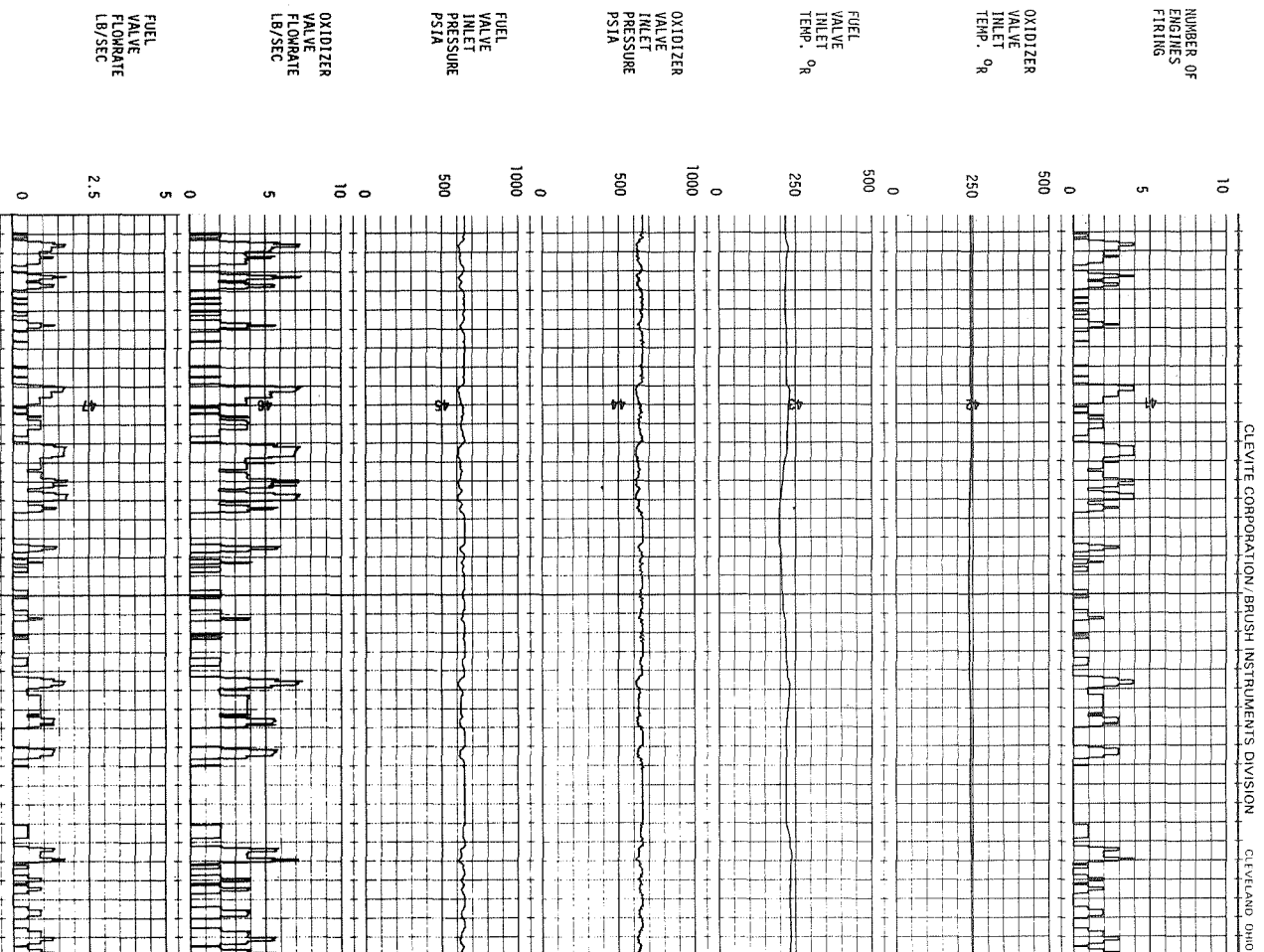

THRUSTERS

REQUIREMENTS

-

WIDE RANGE OF TOTAL IMPULSE
INSTALLATION (BURIED, RE-ENTRY)
HIGH PERFORMANCE, PULSE/S.S.
LIFE (500,000 - 1,000,000 CYCLES)
CHECKOUT STATUS
OPERATIONAL INSENSITIVITY
MINIMIZE INSTALLED WEIGHT
RELIABILITY/MAINTAINABILITY

THERMODYNAMIC EFFECTS AT THRUSTER

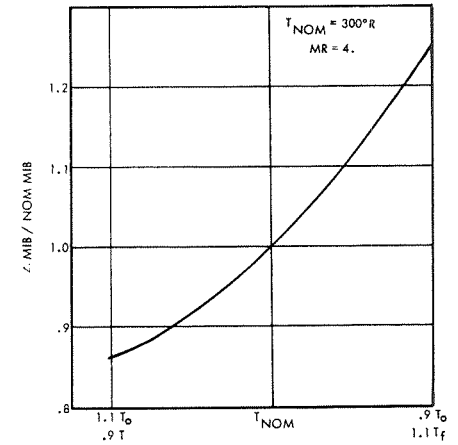
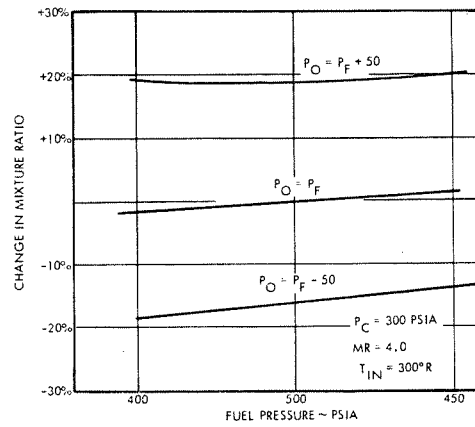
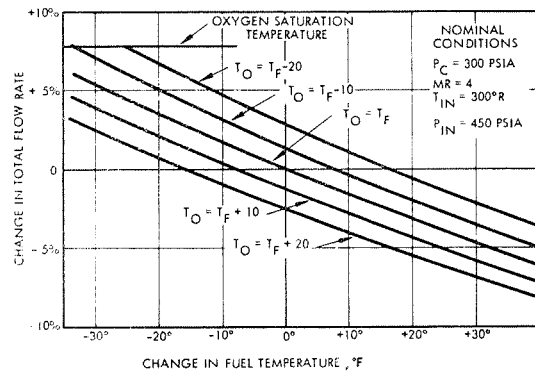

OVERALL APS PERFORMANCE OPTIMIZATION

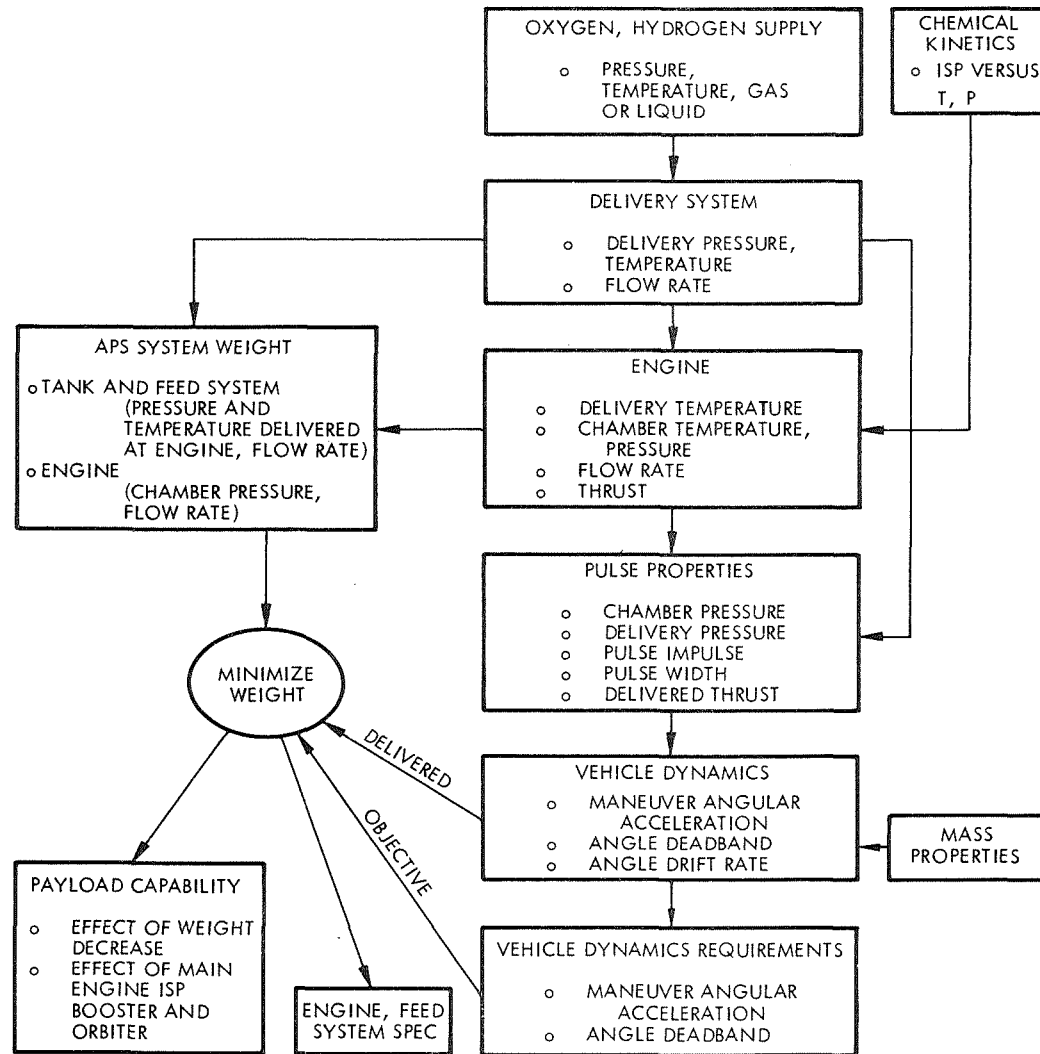

PARTIAL SYSTEM RELIABILITY ASSESSMENT

<u>Subassembly</u>	<u>Percent of All Failures</u>	<u>No. in System</u>	<u>Share of Failures for Each Unit, %</u>
Igniter valve	26.4	48	0.55
Igniter	20.1	48	0.42
Bipropellant valve	18.0	24	0.75
Control valve	8.1	24	0.34
Distribution lines	6.8	32	0.21
Line valve	5.8	24	0.24
Thrust chamber	4.5	24	0.19
Relief valve	4.4	40	0.11
Regulator	2.7	16	0.17
Propellant line	2.4	16	0.15
Accumulator	0.6	20	0.03

APS PROBLEM AREAS

SAFETY

CONTROL AND INSTRUMENTATION

LIFE AND RELIABILITY

MATERIALS

221

ASSEMBLY	PROPELLANT ACQUISITION AND STORAGE	CONDITIONER	DISTRIBUTION	THRUSTER
ASSEMBLY PROBLEM AREAS	PHASE SEPARATION ACCELERATION	DEMAND RANGE RANGE OF INPUT CONDITIONS FREEZING	TEMPERATURE RANGE INSTALLATION	VALVE INSTALLATION DEMAND RANGE

APS TECHNOLOGY PHASING

THE TECHNOLOGY EFFORTS MAY BE DIVIDED INTO THREE OVERLAPPING AND INTERACTING PHASES.

1. FUNDAMENTAL LIMITS. FUNDAMENTAL LIMITS INFORMATION REQUIRED TO ENABLE SYSTEM SELECTION TO BE MADE PRIOR TO THE START OF PHASE C. THIS EFFORT MIGHT INCLUDE:

PHASE SEPARATION, MATERIALS, IGNITION DEVICES, SYSTEM SAFETY, INSTRUMENTATION, LONG LIFE CRYOGENIC TURBOPUMPS, GG/TURBOMACHINERY CONTROLS, COMBUSTION GAS FREEZING, VALVES AND SEALS, BEARINGS AND FILTERS.

2. APPLICATION LIMITS. QUANTITATIVE INFORMATION, REQUIRED FOR SYSTEM DEFINITION. THIS EFFORT MIGHT INCLUDE: MATERIALS, PROPELLANT TRANSFER, VALVES, SEALS, SYSTEM HEALTH DIAGNOSIS, CONNECTER FABRICATION AND CRYOGENIC TURBOMACHINERY.
3. PREDEVELOPMENT. INVESTIGATE SUBSYSTEM INTEGRATION AND INTERACTION EFFECTS. CARRY OUT COMPONENT SELECTION.

APS TECHNOLOGY PHASING

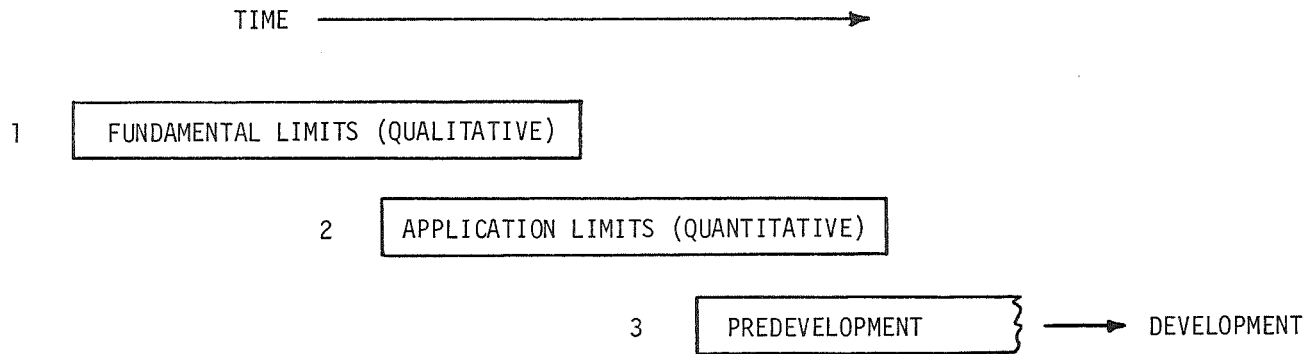

223

1. INFORMATION REQUIRED PRIOR TO SYSTEM SELECTION
2. INFORMATION REQUIRED TO DEFINE SYSTEM REQUIREMENTS.
3. SUBSYSTEM INTEGRATION AND INTERACTION INFORMATION. COMPONENT SELECTION.