

N70-41456

NASA SP-5091

TECHNOLOGY UTILIZATION

# CASE FILE COPY

## A NEW ALUMINUM SAND CASTING ALLOY OF HIGH TOUGHNESS (M-45)

A REPORT



NATIONAL AERONAUTICS AND SPACE ADMINISTRATION

# A NEW ALUMINUM SAND CASTING ALLOY OF HIGH TOUGHNESS (M-45)

A REPORT

By  
R. A. Wood  
Columbus Laboratories  
Battelle Memorial Institute



*Technology Utilization Division*  
OFFICE OF TECHNOLOGY UTILIZATION  
NATIONAL AERONAUTICS AND SPACE ADMINISTRATION  
1970  
*Washington, D.C.*

NOTICE • This document was prepared under the sponsorship of the National Aeronautics and Space Administration. Neither the United States Government nor any person acting on behalf of the United States Government assumes any liability resulting from the use of the information contained in this document, or warrants that such use will be free from privately owned rights.

---

For sale by the Superintendent of Documents,  
U.S. Government Printing Office, Washington, D. C. 20402  
Price 40 cents  
*Library of Congress Catalog Card Number 76-604566*

## Foreword

This report brings together under one cover the information available on an aluminum casting alloy designated M-45 which consists primarily of aluminum admixed with copper, cadmium, magnesium, and titanium. M-45 was designed specifically for use in cryogenic environments where materials of strength, ductility, and toughness are required. Because these properties of the material actually increase as temperatures decrease, M-45 appears to be attractive for many applications at cryotemperatures.

The information presented was obtained from a survey of appropriate Government agencies, manufacturers and potential users of materials having good properties at low temperatures, and of published literature on the subject. The requirements of NASA gave an impetus to the development of the new alloy early in the 1960's. The attractive features of this improved material, specifically its toughness and strength under the stress of high impact at low temperatures, may offer marked advantages in selected applications.

RONALD J. PHILIPS, DIRECTOR  
Technology Utilization Division



## Acknowledgement

The author acknowledges the help of Vernon W. Ellzey, Project Technical Coordinator of Battelle Memorial Institute, in preparing this report, and that of James Wiggins and Henry L. Martin of the NASA Marshall Space Flight Center in obtaining technical information. The data on proposed applications of the M-45 alloy were supplied by R. Sandlin, J. Hess, and H. Gilmore of Propulsion and Vehicle Engineering Laboratory, Marshall Space Flight Center; B. Downs of the John F. Kennedy Space Center, and J. Ambersome, of the Boeing Company.

# Contents

Chapter 1. INTRODUCTION .....	1
Chapter 2. GENERAL CHARACTERISTICS AND WORKING PRACTICES .....	3
Melting Practice .....	3
Casting Design .....	4
Physical Metallurgy .....	4
Chapter 3. MECHANICAL PROPERTIES .....	11
Effect of Aging Treatment on Tensile Properties .....	11
Effect of Test Temperature on Properties .....	12
Effect of Welding on Tensile Strength .....	16
Comparison of M-45 with other Aluminum Casting Alloys .....	18
Chapter 4. STRESS CORROSION .....	21
Chapter 5. CONCLUSIONS .....	25
References .....	29

## CHAPTER 1

# Introduction

The National Aeronautics and Space Administration contracted in the early 1960's for the development of an aluminum casting alloy suitable for cryogenic applications. The principal requirements established for this new alloy were high strength and toughness at very low temperatures, good weldability, and material properties that would facilitate sand casting for good economy. In many structural components of space vehicles, forgings and weldments of aluminum alloy have satisfied the principal criteria. Although the properties of commercially available aluminum-alloy castings have not met the optimum requirements for cryogenic applications, castings are ideal in most cases if the material is compatible with adjoining structures. Consequently, the development of a casting alloy was readily justified and investigations were undertaken.

An aluminum of high purity was conceived as a logical starting point in developing a casting alloy having good properties at low temperatures. Several aluminum-base alloy systems of high purity were examined. Early in the investigations the aluminum-copper system appeared to be very attractive (ref. 1). Later research revealed the benefits that were possible by adding cadmium, magnesium, and titanium to the high-purity aluminum-copper base (ref. 2). Eventually the patented composition (ref. 3), known as M-45, was conceived. It is a combination of the following elements in the amounts indicated:

Cu	3.90 to 4.50 percent
Cd	0.08 to 0.12 percent
Mg	0.06 to 0.10 percent
Ti	0.02 to 0.05 percent
Fe, Si, Cr, Mn, V, Zn	0.029 percent maximum total
Al	Balance

The M-45 aluminum sand-casting alloy was used experimentally in flight and ground-support equipment of intricate design by personnel of the Propulsion and Vehicle Engineering Laboratory, Marshall Space Flight Center. Parts of some assemblies of the ground-support equipment employed in several early Saturn flights were cast from M-45 pig prepared by a commercial firm. Such problems as casting difficulties and a susceptibility of the material to stress corrosion were reported, but these were solved by applying improved foundry techniques and a simple adjustment in the heat treating process. The results of these experiments indicated that the new alloy was entirely suitable for a variety of applications in which materials of high toughness were required.

Although the M-45 alloy appeared to be well suited for operations in the space flight program, its reliability was not established in time for it to be incorporated in flight equipment of the Saturn man-rated program. The new alloy is now well advanced in its development, and is available for a variety of applications in which its superiority over competitive materials can be demonstrated.

This report is a comprehensive technical review of the current status of the M-45 alloy, and a forecast, based on available data, of possible uses of the material. The purpose of the report is to provide information that researchers, designers, and engineers can use: (1) in further study and evaluation of the new alloy; (2) to elucidate the unique characteristics and properties of the material and to identify any difficulties in working with it; and (3) when selecting applications in which the alloy can be used effectively.



## General Characteristics and Working Practices

The M-45 aluminum sand-casting alloy is available in pig form from the Cleveland Foundry, Aluminum Company of America. The Alcoa designation of the grade is CE-82, and the technical manager of ingot sales is E. V. Blackman of Alcoa's Pittsburgh office. The author's survey of the availability of M-45 did not disclose any other commercial foundry handling this material. If a user prefers not to work with prepared pig of the alloy, he can make up the material quite easily by using high-purity alloying stock and standard aluminum-foundry practices.

### MELTING PRACTICE

The M-45 alloy may be prepared without difficulty by following standard aluminum-foundry practices and by observing a few precautionary procedures:

1. Since M-45 is a high-purity base alloy, contamination of the melt from any source must be avoided. Any significant amounts of silicon, iron and other tramp metallics, hydrogen, and both metallic and nonmetallic oxides will degrade the mechanical properties of the alloy. To avoid contamination of this sort, the tools used in processing the melt, such as stirring rods, thermocouple wells, spoons, skimmers, and sparger tubes, should be made of graphite.

2. When preparing M-45 from virgin stock, materials of high purity should be used. Remelted stock of up to 35 percent may be included in the melt, but scrap of uncertain origin or composition should be avoided. Clean, hand-picked, thick-sectioned scrap is preferred to dirty scrap or fines. These materials may be alloyed in crucibles of either clay graphite or silicon carbide.

3. Conventional chlorine gas-fluxing or vacuum-degassing procedures should be followed

to ensure adequate dehydrogenation. High-hydrogen or aluminum-oxide contents result in poor mechanical properties.

4. Temperature control is required to attain desirable characteristics of composition and castability in the material. High holding temperatures or excessive holding times may result in an imbalance of magnesium or cadmium in the melt. Low melting temperatures, of 1300° F or less, can cause the precipitation of Al<sub>2</sub>Ti. (This phenomenon was reported to the author by M. E. Stonebrook of Alcoa's Cleveland Foundry in May 1969.) The castability of the melt is dependent upon both its pouring temperature and the size and wall thickness of the casting.

5. Since cadmium vapors are highly toxic, adequate ventilation of the crucible-furnace site and respiratory masks for personnel must be provided.

Numerous heats of the M-45 alloy have been prepared in laboratory and production facilities. The typical procedure used in the laboratory consisted of adding copper alloy (Al-20Cu), titanium alloy (Al-6Ti), and elemental cadmium (wrapped in aluminum foil) to a high-purity aluminum base in a clay-graphite crucible. These additions were made after the temperature of the aluminum base reached 1300° F or above, and they were stirred into the melt with a graphite rod as the temperature of the melt continued to rise. The temperature of the heat was kept above 1300° F to prevent the formation of Al<sub>2</sub>Ti.

The addition of elemental magnesium was made after the dehydrogenation operation in one laboratory where the chlorine gas-fluxing method was used. Magnesium can be added prior to the degassing operation, however, if a vacuum-degassing chamber is used to eliminate the hydrogen gas. A holding period of

10 minutes was found to be sufficient for degassing by the chlorine gas-fluxing method; one of 20 minutes was required when the vacuum-chamber method was used. The maximum temperature of the heats in both the gas-fired and coke-fired, pit-type furnaces used in the laboratories was 1425° F.

In the experiments the M-45 alloy was poured at temperatures ranging from 1280° to 1420° F. It is preferable, however, to pour at 1300° F or above. The pouring-temperature range prescribed in reference 3 is from 1275° to 1350° F, allowing for adjustments to be made depending on the size and wall thickness of the casting. When casting, standard metal-handling procedures, such as careful skimming, minimum agitation of the melt, and the use of clean, dry ladles, should be employed.

#### CASTING DESIGN

The M-45 alloy is essentially a sand-casting material, although other casting techniques may eventually prove to be applicable. The behavior of this alloy in the mold is much like that of other aluminum-copper compositions; for example, 195 and KO-1. In designing castings of this material, therefore, considerations of shrinkage allowances, fillet dimensions, wall thicknesses, gating and risering, and solidification patterns should parallel accepted design practices for similar aluminum-copper compositions. A booklet, "Standards for Aluminum Sand and Permanent Mold Castings," published by the Aluminum Association, contains guidance for designing castings.

Hot-shortness and tearing have been experienced with M-45 castings. They are defects characteristic of aluminum-copper casting alloys in which stress concentrations occur because of the casting design. It is advisable to use recommended remedial design practices, such as increasing the size of fillets, so that the areas of the castings that are liable to cause stress concentrations will be minimized. In general, simplifying the geometry of the castings will aid in reducing stress concentrations, and allow the foundry to produce castings with fewer defects.

It has not been found necessary to use special sand compositions in the casting of M-45

alloy. A mold-reaction problem has not been observed. For purely mechanical reasons, a mold spray has been used on occasion to eliminate the sand washing problem, but generally, this procedure was found to be unnecessary. An oiled, urea-bonded foundry sand of a composition usually employed in aluminum casting can be used. Excessive hardness of molds or cores should be avoided, because it may aggravate the hot-short and tearing problem caused by the build-up of stress concentrations.

#### PHYSICAL METALLURGY

The M-45 alloy is a moderately high-strength, extremely tough composition of the precipitation-hardening type, and is based essentially on the aluminum-copper system. The casting alloy is unique in that it contains a small amount of cadmium, an additive that increases its strength without degrading its ductility or toughness. In fact, ductility and toughness are improved along with strength in the cadmium-modified base alloy. The following chart shows the room-temperature properties of samples cut from pump-housing castings and tested in the T6 temper (ref. 2). The composition of sample A is, by percent, Al-4.5Cu-0.25Mg-0.1Ti and of sample B is Al-4.5Cu-0.1Cd-0.1Mg-0.05Ti.

	Sample A	Sample B
Ultimate strength, ksi	47	53
Yield strength, ksi	41	51
Elongation, %	1.5	3.0
Reduction in area, %	3.4	6.4
Charpy v-notch value, ft-lb.	6.4	13.2
Charpy v-notch value, ft-lb.	6.4	13.2

Cadmium is believed to affect the metallurgy of the M-45 alloy in the same way that silver affects the KO-1 and CH-70 compositions (Al-Cu-Mg-Ag type alloys; silver of up to 1 percent) (ref. 4). The studies by Hardy (refs. 5 through 7) have shown that small amounts of cadmium have a definite influence on the course of precipitation of copper in aluminum. The natural aging of aluminum-copper alloys is depressed, but the rate of artificial aging is accelerated by a factor between 3 and 8. Hardy's

research also has shown that the absolute strength of aluminum-copper alloys is increased by additions of cadmium.

The magnesium added to the M-45 alloy is believed to enhance further the strength of this material. Hardy found that, whereas magnesium (0.06 percent) negated the effects of small indium or tin additions on the accelerated-aging reaction found in aluminum-copper-base alloys, it did not diminish the influence of cadmium in this respect (ref. 5). Polmear reports that silver additions in aluminum-copper-magnesium alloys significantly affect the aging characteristics, and suggests that this might be caused by a preferred affinity between magnesium and silver atoms (ref. 8). The same relationships may exist for magnesium and cadmium, which would explain the beneficial aging and strengthening effects observed.

The small addition of titanium is made for the purpose of grain refinement. Iron, silicon, manganese, chromium, vanadium, and zinc, especially iron and silicon, are considered as impurities in the M-45 alloy. These elements are maintained at very low levels to avoid degradation of properties, particularly impact properties, at low service temperatures.

The chief strengthening ingredient in M-45 alloy is copper. High strengths are achieved by following the thermal-treatment patterns usually used for other high-strength aluminum-copper-base casting alloys; that is, solution heat treatment plus artificial aging.

Appreciable diffusion of eutectic and intermetallic compound segregates does not occur during solidification of a casting because this physical change and the subsequent cooling of the solid material are much too rapid. Thus,

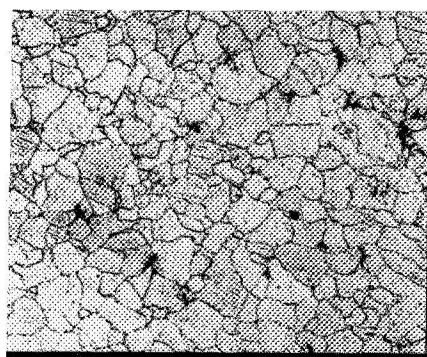

SOAK TIME 16 HOURS

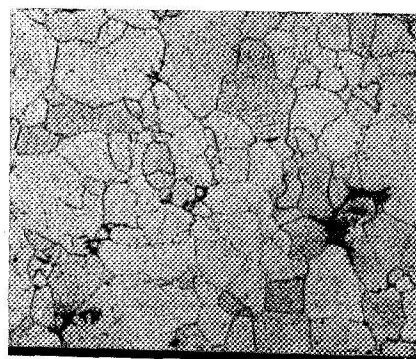

SOAK TIME 24 HOURS

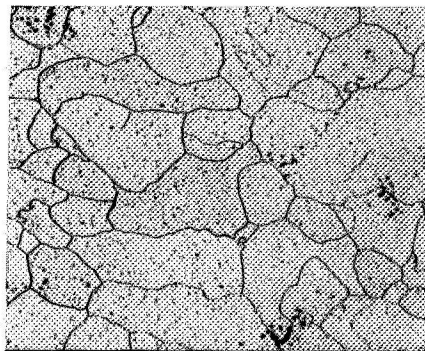

SOAK TIME 48 HOURS

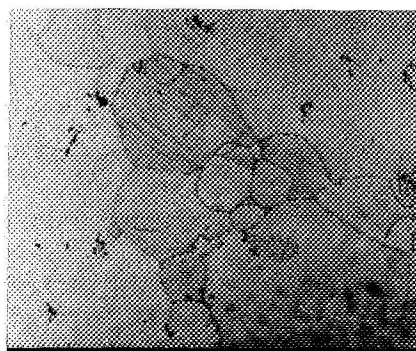

SOAK TIME 72 HOURS

FIGURE 1.—Macrostructures of aluminum casting alloy M-45 after solution heat treatment at 960° F (516° C). (Ref. 10)

solution heat treatment is practiced to homogenize copper distribution by dissolution of much of the Al-Cu phase found in M-45 alloy castings.

Solution temperature control is very important, since too high temperatures may cause eutectic melting, while too low temperatures will not permit sufficient homogenization or adequate supersaturation of copper in solid solution. Super-saturated solid solution is, of course, a requisite to take advantage of the precipitation-hardening reaction that occurs during subsequent aging heat treatments. Quenching from the solution temperature at a rate fast enough to retain the solute in solution is another requisite. A quench in water maintained at a temperature between 50° and 150° F is recommended for the M-45 alloy.

The recommended temperature range for the solution heat treatment of the M-45 alloy is 960° to 1000° F. The recommended time for the process is between 16 and 24 hours. Microstructures that are obtained after such heat treatments and the effect of holding time on grain are shown in figures 1, 2, and 3 (ref. 9). Generally, the time selected for the solution heat treatment is based on two considerations: (1) the time must be long enough to allow the solution to homogenize by diffusion, and (2) the time must be limited to prevent the growth of excessive grain size in the material. As shown in figure 4, the as-cast grain size is often variable because of differences in the cooling rate of different section thicknesses in a casting. This condition may affect grain-size control during solution heat treatment, unless long

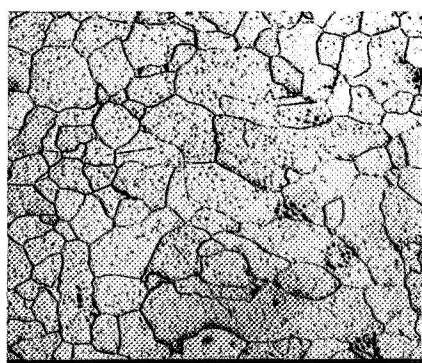

SOAK TIME 16 HOURS

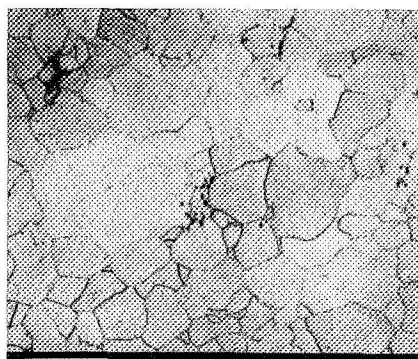

SOAK TIME 24 HOURS

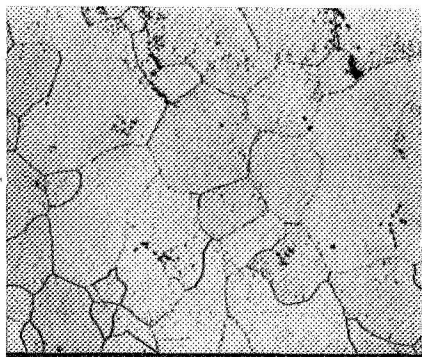

SOAK TIME 48 HOURS



SOAK TIME 72 HOURS

FIGURE 2.—Macrostructures of aluminum casting alloy M-45 after solution heat treatment at 980° F (527° C). (Ref. 10)



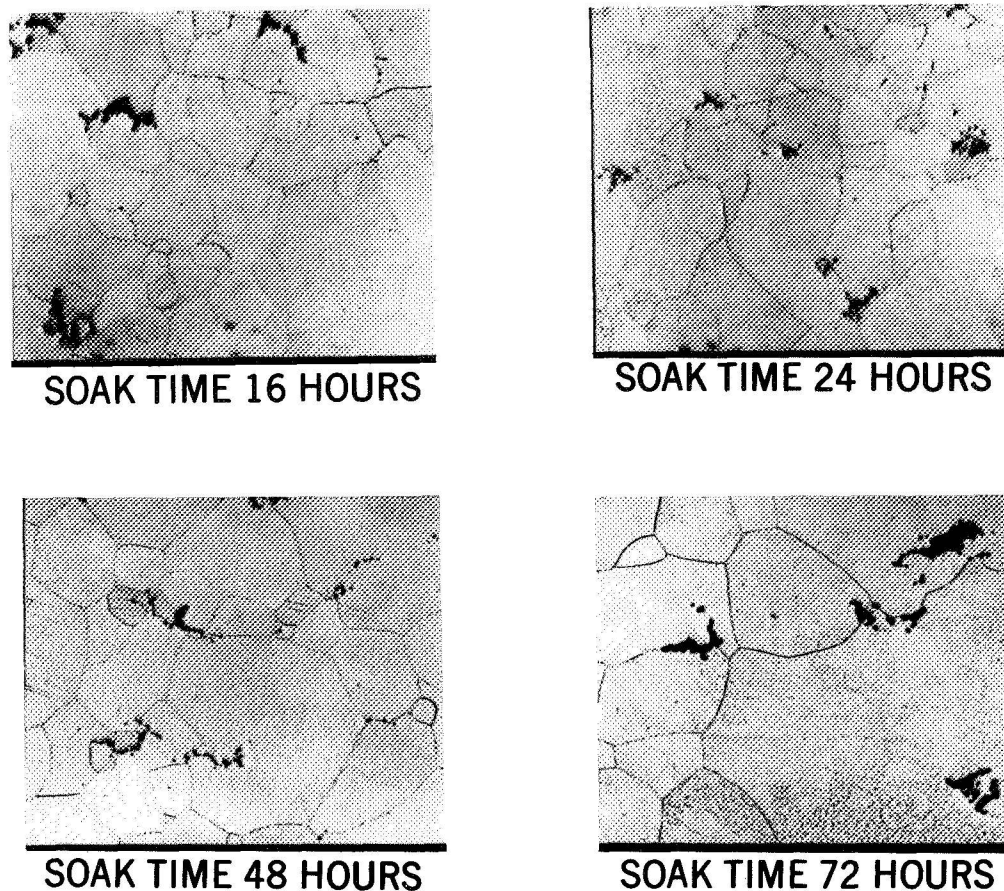
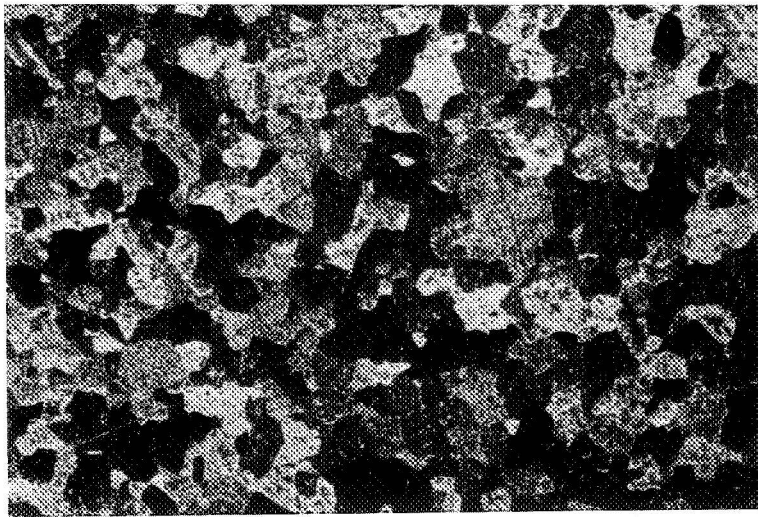

FIGURE 3.—Macrostructures of aluminum casting alloy M-45 after solution heat treatment at 990° F (532° C). (Ref. 10)

times are used, which will tend to equilibrate grain size at a moderately large dimension.

The effect of solution-heat-treatment temperature has not been thoroughly examined for the M-45 composition. Sufficient data, however, have been obtained to show that the strength response of the alloy will increase during subsequent aging as the solution temperature is increased. As shown in figure 5 (ref. 10), a slight decrease in solution temperature can result in lower solid-solution concentration; consequently, a lower strength response can be expected during aging. This effect is reflected in the hardness data given in tables 1 and 2 (ref. 10).

A wide range of mechanical properties can be made available with the M-45 alloy depending on the solution and aging heat treatments used. The original aging heat treatment recommended for this material was 16 hours at 325° F. This heat treatment, however, was found to make the alloy susceptible to stress-corrosion damage (see ch. 4). Therefore, an overaging heat treatment was recommended for production castings to alleviate this problem. Because overaging does not occur in practical exposure periods at 325° F, temperatures higher than 325° F were suggested for the process (ref. 9). The overaging treatment of 26 hours at 375° F was first used for produc-



AS-CAST (AREA OF SLOW COOL)

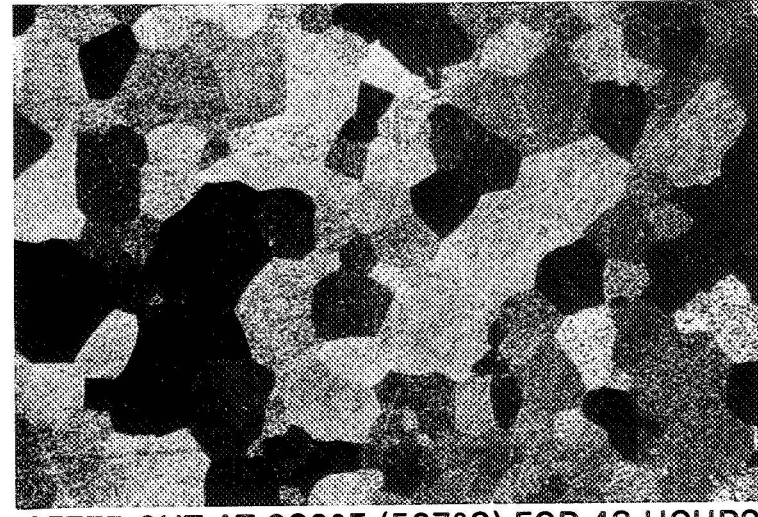

AFTER SHT AT 980°F (527°C) FOR 48 HOURS

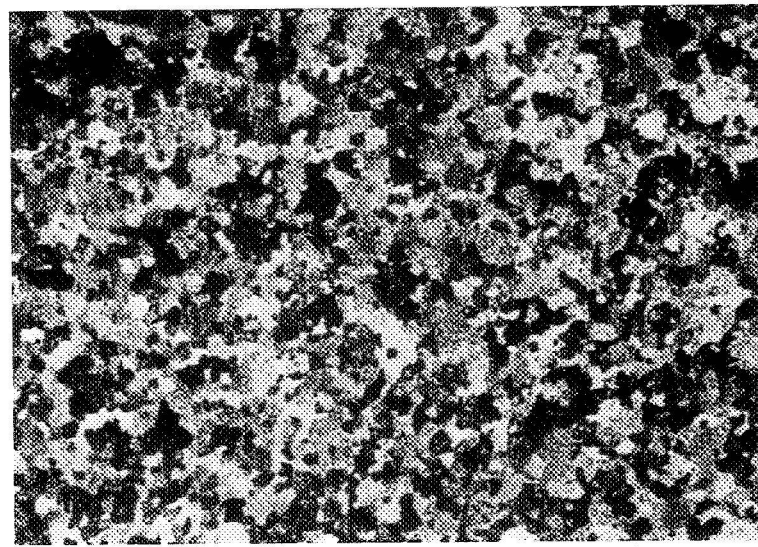

AS-CAST (AREA OF RAPID COOL)

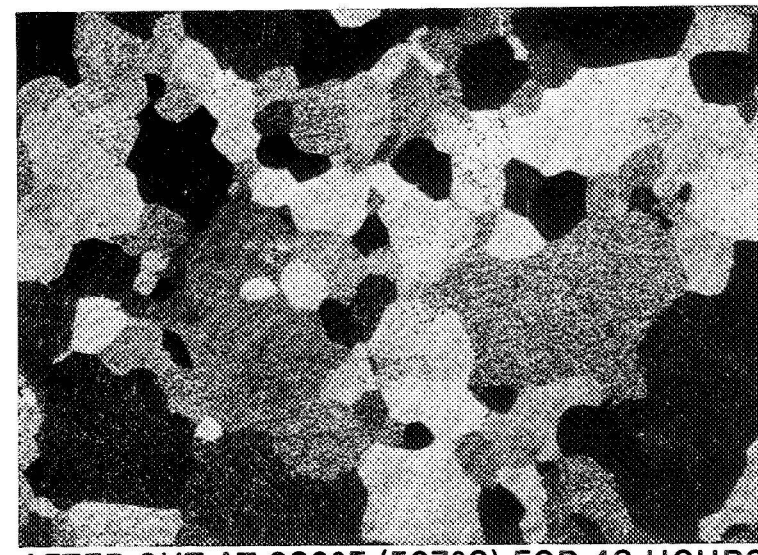

AFTER SHT AT 980°F (527°C) FOR 48 HOURS

FIGURE 4.—Typical macrostructures of aluminum alloy M-45 in the as cast and solution heat treated (SHT) conditions (ref. 10).

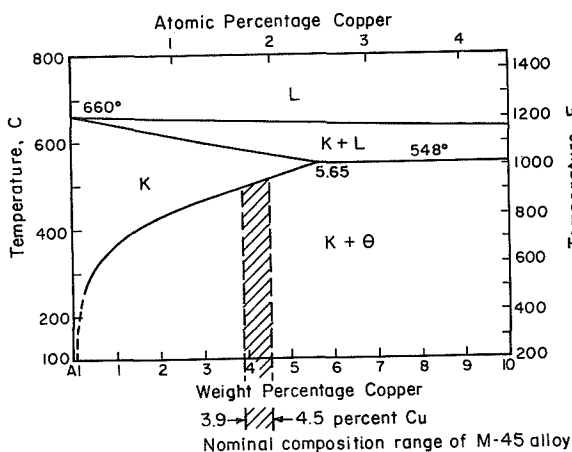

tion castings, but this treatment was considered too severe to take full advantage of the strength of the alloy, and at the same time, maintain acceptable stress corrosion resistance (ref. 9). Ultimately, the overaging heat treatment of 12 hours at 400° F was recommended. Hardness data for various aging conditions are given in table 3.

FIGURE 5.—Partial equilibrium diagram of aluminum-copper system and composition range of M-45 alloy. Note shallow slope of the solid solubility line at intersect with composition range (Ref. 11).

TABLE 1.—Hardness of Solution-Heat-Treated M-45 Alloy\*

Solution heat treatment temperature	Rockwell "F" hardness						
	Solution time, hours						
	0	1	8	16	24	48	72
990° F (482° C)	52	40	45	34	53	36	48
920° F (493° C)	52	45	50	56	56	60	60
940° F (504° C)	52	49	56	56	57	55	58
960° F (516° C)	52	48	57	50	54	56	57
980° F (527° C)	52	57	58	59	59	58	57
990° F (532° C)	52	52	59	58	57	58	58

\* Average value from nine or more hardness values.

TABLE 2.—Hardness of Solution-Heat-Treated Plus Aged M-45 Alloy\* (Artificially aged at 325° F (163° C) for 16 hours)

Prior solution heat treatment temperature	Rockwell "B" hardness					
	Prior time SHT, hours					
	1	8	16	24	48	72
920° F (493° C)	27	52	56	64	61	61
940° F (504° C)	53	66	70	70	73	72
960° F (516° C)	49	68	70	74	73	75
980° F (527° C)	69	72	77	75	72	73
990° F (532° C)	65	73	75	74	74	74

\* Average value from nine hardness values.

TABLE 3.—Hardness of Solution-Heat-Treated Plus Aged M-45 Alloy\* (Solution heat treated at 990° F ± 10 (532° C ± 6) for 24 hours prior to aging)

Artificial aging temperature	Rockwell "B" hardness									
	Aging time, hours									
	1	4	6	8	12	16	18	24	48	72
325° F (163° C)	37	62	—	75	—	76	—	77	76	75
350° F (177° C)	69	74	—	74	—	74	—	74	71	72
375° F (190° C)	68	69	—	73	72	69	69	69	67	66
400° F (204° C)	71	73	70	69	68	66	—	65	62	60

\* Average values from three test coupons.



## Mechanical Properties

The unusual combination of moderately high strength, good ductility, and extremely high toughness that can be obtained with the M-45 alloy, especially at very low temperatures, is its outstanding advantage. This advantage, together with others, such as the low density and good weldability of the material, and the ease with which it can be heat-treated, have been recognized by NASA in applying this material to hardware for the space-flight effort. At present, however, data on the mechanical properties of the alloy are limited. More abundant data would be desirable in determining the broad usefulness of the material. Further research is needed to obtain more extensive information. The available data, however, are sufficient to indicate the potential of

the M-45 casting alloy. These data are presented to show ranges of typical mechanical properties that can be obtained.

### EFFECT OF AGING TREATMENT ON TENSILE PROPERTIES

Cast cylindrical ( $\frac{1}{2}$ -inch diameter) test bars of M-45 alloy were tested for tensile strength at room temperature, after they had been given both a solution treatment at 990° F and selected aging treatments, in an attempt to determine the range of strengths available for the material (ref. 9). Selected data from these tests are tabulated in table 4. The tensile yield strengths of the samples that were aged at temperatures of 325°, 375° and 400° F, respectively, are plotted in figure 6. This plot shows the effect of overaging when the mate-

TABLE 4.—Room-Temperature Tensile Properties of M-45 Alloy in the 990° F Solution Heat Treated\* Plus Aged Conditions  
(Artificial aging of  $\frac{1}{2}$ -inch-diameter cast test bars indicated.)

Tensile properties **	Aging time, hours						
	1	4	8	16	24	48	72
Ultimate strength, ksi				325° F aging			
Yield strength, ksi	43	48	51	54	55	54	54
Elongation, %	19	13	6	4	2.5	2	1.5
Ultimate strength, ksi				350° F aging			
Yield strength, ksi	52	56	56	55	55	54	54
Elongation, %	38	48	52	52	52	51	50
Elongation, %	8	5	4.5	2	3	2.5	3
Ultimate strength, ksi				375° F aging			
Yield strength, ksi	55	57	56	54	54	52	52
Elongation, %	46	51	53	50	50	45	42
Elongation, %	5	3	2	2	2	3	3
Ultimate strength, ksi				400° F aging			
Yield strength, ksi	54	56	54	53	52	50	50
Elongation, %	49	51	50	46	45	42	38
Elongation, %	4	3	3	3	3	4	5

\* 24-hour solution heat treatment terminated by water quenching.

\*\* Average values for three test coupons. Yield strengths are 0.2 percent off set values. Elongation values are percent in 2 inches.

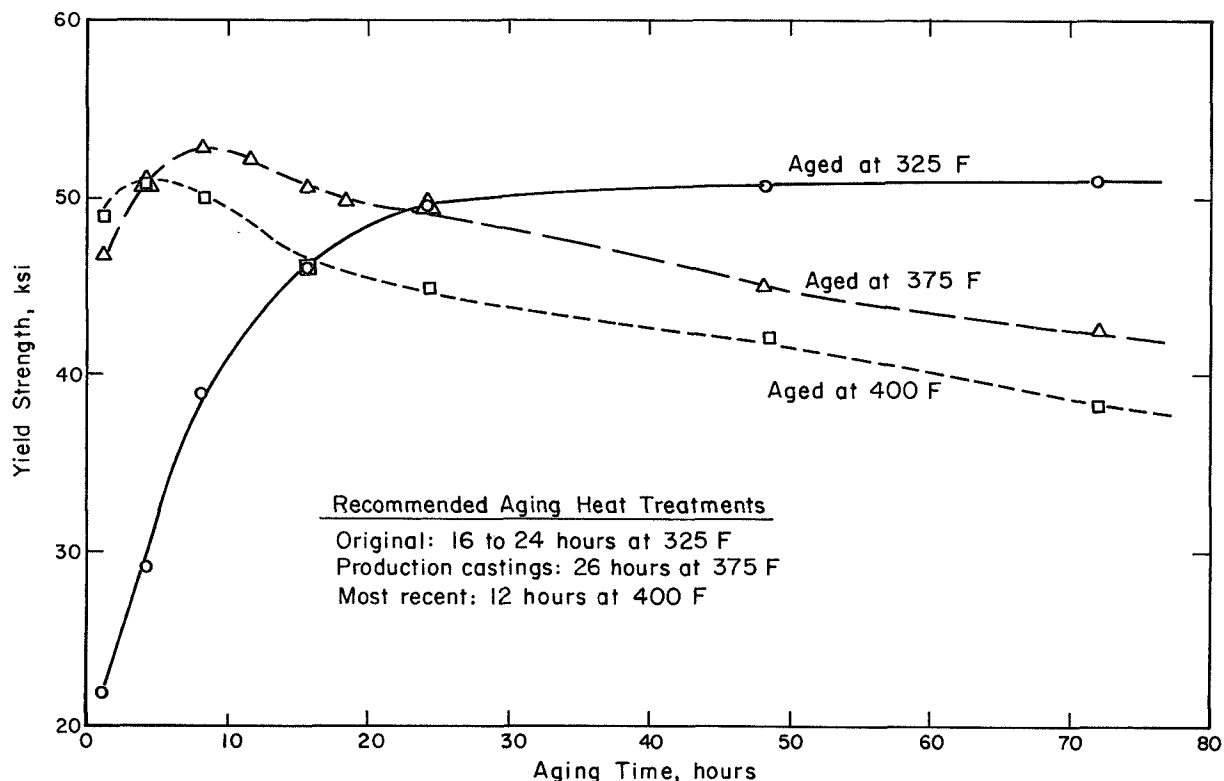

FIGURE 6.—The effect of selected artificial aging heat treatments on the room-temperature tensile yield strengths of M-45 alloy. (990° F solution heat treatment)

rial is aged at the higher temperatures. The original aging treatment of 16 to 24 hours at 325° F (T6 condition) gives the material approximately the same tensile yield strength as that obtained by the 375° F overaging treatment (T7 condition) used for production castings. The advanced overaging reaction of the 400° F treatment is apparent in the illustration, although the 12-hour treatment at 400° F (most recently recommended) does not greatly reduce the tensile yield strength.

#### EFFECT OF TEST TEMPERATURE ON PROPERTIES

The effect of test temperature on the tensile and impact properties of the M-45 alloy was evaluated by testing samples cut from sand-cast pump housings. Photographs of the pump housing are shown in figure 7 (ref. 2). Samples were cut from the flanges and walls as shown in figure 8; test specimen dimensions are shown in figure 9 (ref. 11).

The castings were heat-treated to the T6 condition prior to sampling (ref. 2):

Analyzed composition, %	Casting No.		
	57-2	64-1	64-3
Cu	5.36	4.20	4.20
Cd	0.10	0.09	0.09
Mg	0.10	0.06	0.06
Ti	0.01	0.03	0.03
Other	0.04	0.04	0.04
Solution treatment aging treatment			
Time, hr	24	24	40
Temperature, ° F	1000	1000	1000
Time, hr	10	16	16
Temperature, ° F	325	325	325

Tensile data are given in table 5 and figure 10, and impact data in table 6 and figure 11 (ref. 11). Except for the subsize tensile samples used, standard ambient and low-temperature testing techniques were followed.

The stress-strain curves obtained during the tensile testing at both room and low temperatures are shown in figure 12. Although not ap-

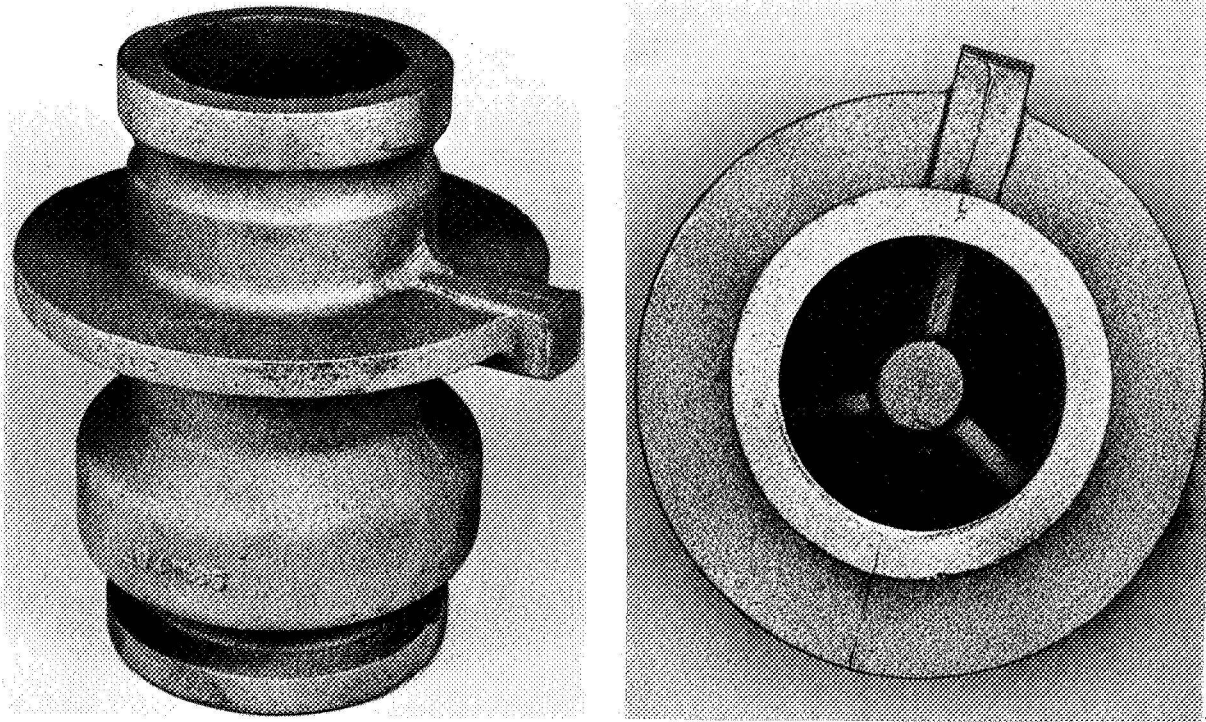

FIGURE 7.—Oblique side view and top view of pump housing cast from M-45 alloy using conventional sand casting procedures (ref. 2).

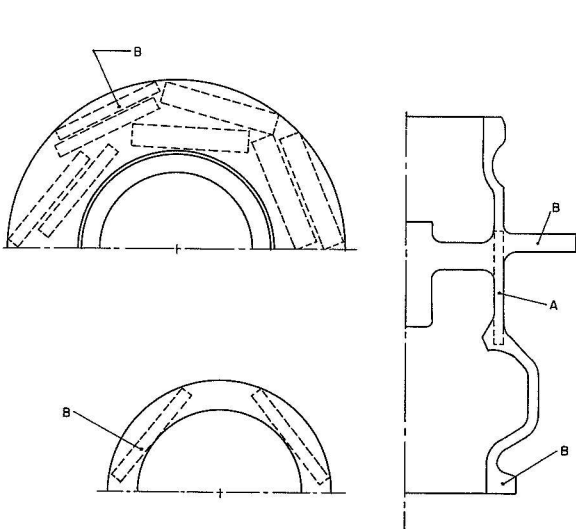
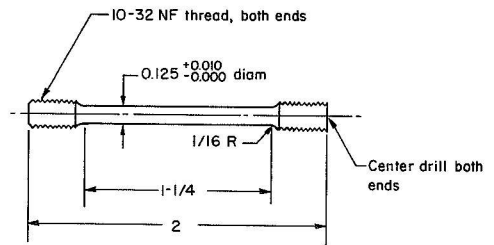
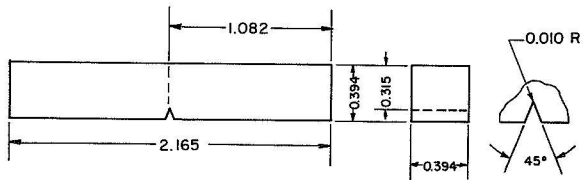

FIGURE 8.—Schematic diagram of pump housing cast from M-45 alloy showing location of samples cut from casting walls (A) and flanges (B) (ref. 12). (Tensile only from location A; tensile and impact from location B.)



Tensile Test Specimen



V-Notched Charpy Specimen

FIGURE 9.—Test specimen geometries (ref. 12).

TABLE 5.—*Room- and Low-Temperature Tensile Results Obtained on Solution Treated (1000°F) Plus Aged (325°F) Samples Cut From Pump Housings Sand Cast From M-45 Alloy*

+26.7	+80	57-2-A-1	48.1	45.8	6.0	GL	
		57-2-A-2	46.7	44.0	6.0	GL	
		57-2-B-3	50.5	48.0	5.0	GL	
		64-1-A-1	47.3	46.0	4.0	GL	
		64-1-B-2	46.6	44.6	4.0	GL	
		64-1-B-3	50.6	49.7	4.0	GL	
		64-3-A-1	44.5	39.4	5.0	GL	
		64-3-A-2	46.7	40.2	7.0	GL	
		64-3-B-3	48.2	45.0	4.0	GL	
			Average	47.7	44.7	5.0	
-73.4	-100	57-2-A-4	49.5	48.6	5.0	OEG	
		57-2-A-5	51.3	49.9	5.5	GL	
		57-2-B-6	53.9	52.5	4.0	GL	
		64-1-A-4	48.1	48.1	2.0	GL	
		64-1-B-5	50.8	49.3	4.0	GL	
		64-1-B-6	50.5	48.0	3.0	GL	
		64-3-A-4	43.4	41.2	6.0	GL	
		64-3-B-5	47.6	44.2	—	OGL	
		64-3-B-6	51.4	46.6	5.0	GL	
			Average	49.6	47.6	4.3	
-129.0	-200	57-2-A-7	50.9	48.5	4.0	GL	
		57-2-B-8	57.5	54.5	4.5	GL	
		57-2-B-9	49.9	49.0	4.0	GL	
		64-1-A-7	56.9	(c)	6.0	GL	
		64-1-A-8	51.7	50.4	—	OGL	
		64-3-A-7	43.9	43.6	3.0	GL	
		64-3-A-8	48.6	46.2	6.0	GL	
		64-3-B-9	47.5	41.9	8.0	GL	
			Average	50.9	47.7	5.1	
		-196.0	-320	57-2-A-10	59.2	55.2	4.0
57-2-A-11	55.8			53.7	6.0	GL	
57-2-B-12	64.4			58.8	6.5	GL	
64-1-A-10	57.0			54.5	—	OGL	
64-1-B-11	58.1			55.7	3.0	GL	
64-1-B-12	59.0			54.6	5.0	GL	
64-3-A-10	51.7			44.8	9.0	GL	
64-3-A-11	51.3			44.6	10.0	GL	
64-3-B-12	52.9			49.9	5.5	GL	
	Average			56.6	52.4	6.4	
-252.7	-423	57-2-A-13	70.2	63.3	6.5	EC	
		57-2-A-14	72.9	61.5	7.0	EC	
		57-2-B-15	71.3	(c)	—	OGL	
		64-1-A-13	65.4	55.0	7.0	GL	
		64-1-A-14	75.7	56.7	12.0	GL	



Test temperature °C      °F		Specimen <sup>(a)</sup> No.	Ultimate tensile strength, ksi	Yield strength, ksi	Elongation, % in 4D	Fracture <sup>(b)</sup> location
		64-1-B-15	73.2	(c)	11.0	EC
		64-3-A-13	67.0	51.8	11.0	GL
		64-3-A-14	68.8	52.1	11.0	GL
		64-3-B-15	70.8	57.6	—	OEG
		Average	70.6	56.9	9.4	

(a) Example: 57-2-A-13 means heat 57, casting number 2, test location area "A", test specimen 13.

(b) EC—Extensometer clamp

OEG—Outside extensometer gage length

GL—Gage length

OGL—Outside gage length

(c) Malfunction of extensometer prevented determination of yield strength.

(d) —T6 condition was within Rockwell hardness range (RB) 72 to 76.

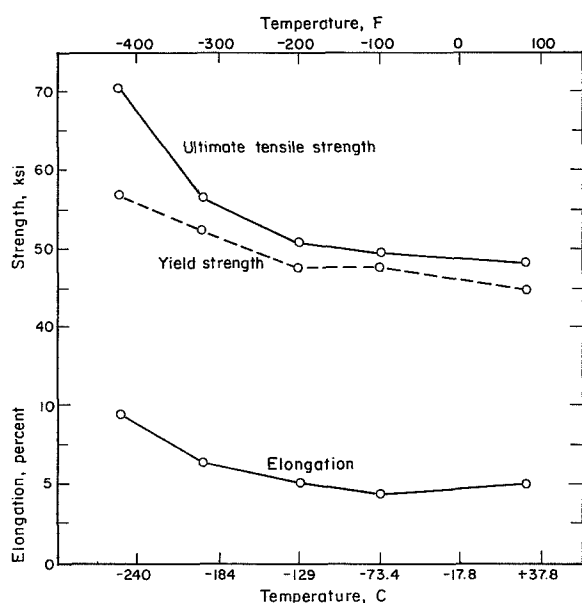

FIGURE 10.—Effect of test temperature on tensile properties of sand cast M-45 alloy. Solution heat treated at 1000° F plus aged at 325° F (T6 condition).

parent in this display, the elastic modulus of the material increased with decreasing temperatures, as would be expected. This effect is shown in figure 13. Similarly, the data on tensile strength and ductility are plotted versus temperature in figure 12, and they clearly show

TABLE 6.—Room- and Low-Temperature Charpy V-Notch Impact Results Obtained on Solution Treated (1000° F) Plus Aged (325° F) Samples Cut From Pump Housings Sand Cast From M-45 Alloy

Specimen no.	Charpy impact properties, ft-lb		
	26.7° C (+80° F)	-196° C (-320° F)	-252° C (-423° F)
57-2	14.0	25.0	21.5
57-2	18.3	17.8	18.3
64-1	9.8	12.3	14.8
64-1	11.5	18.5	11.0
64-1	—	—	15.0
64-3	14.3	16.8	14.5
64-3	—	21.0	16.0
64-3	—	—	13.0
64-3	—	—	16.8
64-3	—	—	14.3
Average	13.6	18.6	15.5

the increase in strength expected with decreasing test temperature. It is interesting to note that tensile ductility also is improved with decreasing temperature. The impact-absorption-energy values of table 6, plotted versus test temperature in figure 13, also indicate no degradation of toughness in the material at very low temperatures, although such values at -423° F are slightly lower than those obtained at -320° F (but higher than at room temperature). Collectively, the avail-

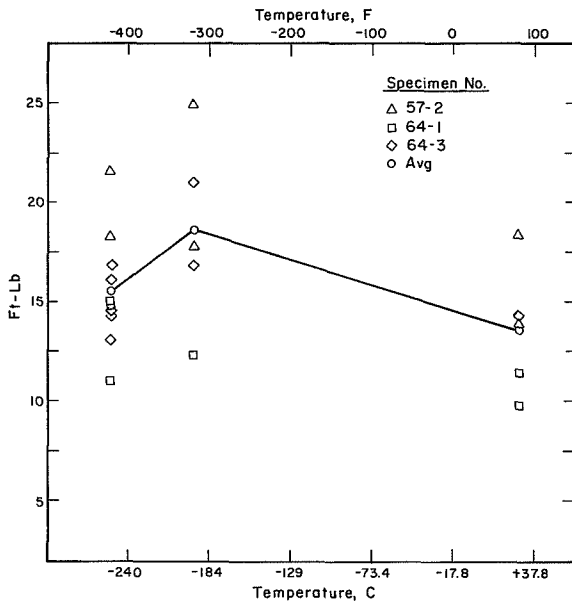

FIGURE 11.—Effect of test temperature on Charpy V-notch impact properties of sand cast M-45 alloy. Solution heat treated at 1000° F plus aged at 325° F (T6 condition).

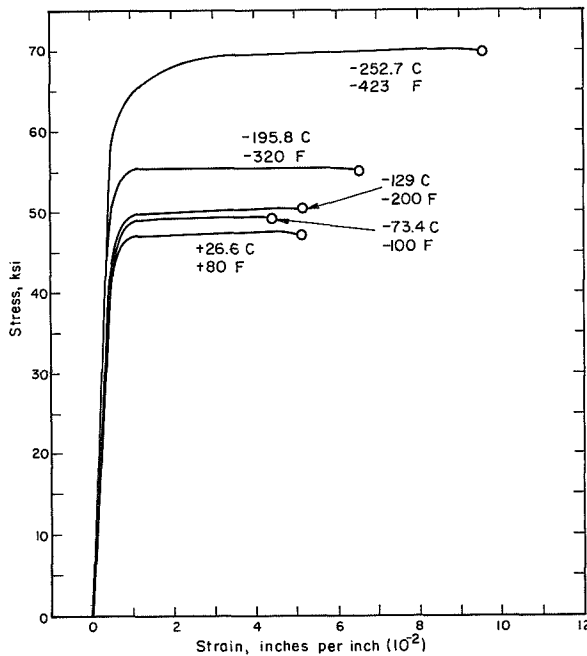

FIGURE 12.—Stress-strain curves obtained for M-45 sand cast samples at room and low temperatures (ref. 12). Samples solution heat treated at 1000° F plus aged at 325° F (T6 condition).

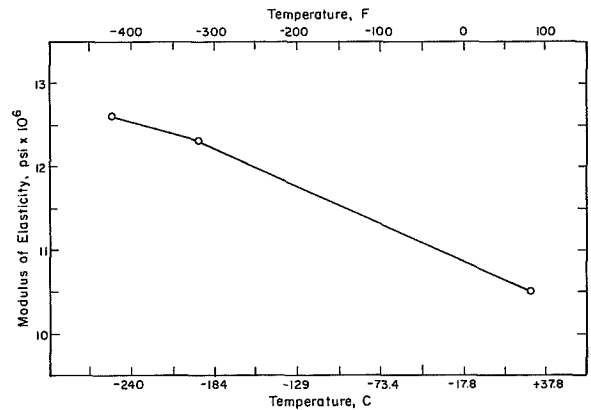

FIGURE 13.—Modulus of elasticity versus test temperature data obtained for sand cast M-45 alloy samples (ref. 12). Solution heat treated at 1000° F plus aged at 325° F (T6 condition).

able tensile- and impact-strength data indicate the special suitability of the M-45 alloy for cryogenic applications. No other sand-casting aluminum-base alloy combines the features of high strength and extreme toughness at these low temperatures.

**EFFECT OF WELDING ON TENSILE STRENGTH**

Cast, heat-treated (T6) samples of M-45 alloy were joined to 2219 aluminum alloy plate (T87 condition) in a two-pass square-butt-joint configuration (fig. 14) by using the automatic gas-tungsten-arc (GTA) welding procedure (ref. 11). Aluminum alloy 2319 was used as filler wire in this operation. Tensile samples were machined from this assembly so that reduced sections of tensile bars included the weld joint at a right angle to the direction of stress. Tests were conducted at both room and low

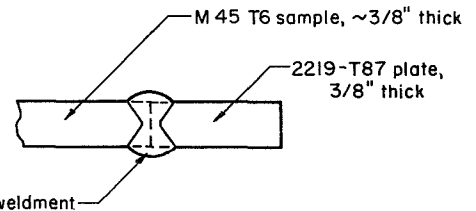

FIGURE 14.—Weld joint assembly of M-45 casting alloy and 2219 plate made using automatic GTA procedure and 2319 filler wire (ref. 12).

temperatures; the resulting data are given in table 7. The average strength of the automatic GTA weldments at room temperature was somewhat lower than the strength of cast M-45 in the T6 condition, as would be expected. A

TABLE 7.—*Tensile Strength of Weldments Prepared From M-45-T6 Sand Castings and 2219-T87 Plate Joined by 2-Pass Automatic GTA Procedure Using 2319 Filler Wire (As-Welded Strengths)*

Test temperature		Specimen no.*	Ultimate tensile strength, psi		
°C	°F				
+26.7	+80	57-2-1	33,500		
		57-2-2	37,500		
		57-2-3	37,200		
		57-2-4	35,700		
		64-1-1	36,600		
		64-1-2	36,100		
		64-1-3	38,000		
		64-3-1	34,000		
		64-3-2	36,500		
		64-3-3	37,200		
		64-3-4	37,900		
		Average		36,200	
		-73.4	-100	64-1-10	37,700
				64-3-11	37,500
64-3-12	40,700				
64-3-13	37,400				
Average		38,500			
-196	-320	57-2-5	52,500		
		57-2-6	43,300		
		64-1-5	37,600		
		64-1-6	48,400		
		64-1-7	51,300		
		64-3-5	40,300		
		64-3-6	36,100		
		64-3-7	38,300		
		Average		43,500	
		-252.7	-423	57-2-7	49,700
57-2-8	46,500				
57-2-9	45,000				
64-1-8	49,700				
64-1-9	52,300				
64-3-8	53,600				
64-3-9	50,100				
64-3-10	48,200				
Average				49,400	

\* Example: 57-2-7 means heat 57, casting number 2, test specimen number 7.

significant increase in weld strength, however, was found with decreasing test temperature (fig. 15).

Figure 15 also includes data obtained for weldments made by joining two castings of M-45 (T6 condition) (ref. 11). Single-pass manual GTA procedures and 2319 filler wire were used in this case. The butt-joint geometry and the location of the tensile sample are shown in figure 16. Tensile samples contained the joint in the center of the reduced section. The low as-welded strength of 25.7 ksi was attributed to the extended exposure of the sample to an elevated temperature. This inherent characteristic of manual welding eliminated the T6 condition of the castings. The as-welded Rockwell "B" hardness averaged 29.5, down from the Rockwell "B" hardness value of 72 to 76, which is characteristic of the alloy in the T6 condition. A reheat treatment of a welded sample comprising a 40-hour solution treatment at 100° F (water quench) plus aging for 16 hours at 325° F, almost doubled the

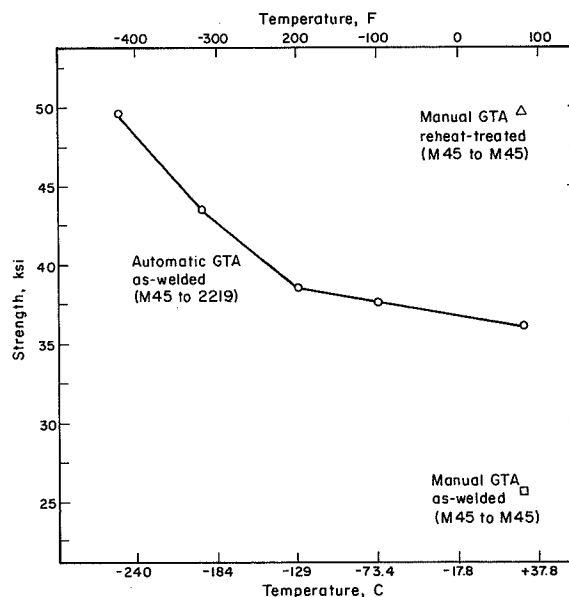

FIGURE 15.—Effect of test temperature on tensile strength of weldments incorporating M-45-T6 sand cast material to 2219-T87 plate (automatic GTA welds) or M-45-T6 to M-45-T6 castings (manual GTA welds) (ref. 12). The weldments were made with 2319 filler wire.

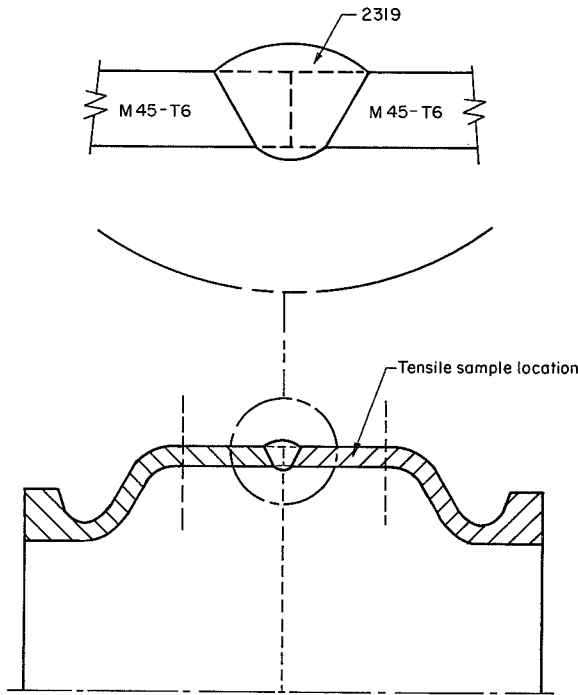

FIGURE 16.—Weld joint assembly of M-45-T6 castings (ref. 12).

strength of the material, a gain from 25.7 ksi to 49.7 ksi. These data on reheat treatment suggest that full mechanical properties might also be restored to weldments of M-45 alloy processed by the automatic GTA method. Collectively, the weld data developed to date indicate no major problems in assembling M-45 components by welding, and suggest an increased versatility of the material.

#### COMPARISON OF M-45 WITH OTHER ALUMINUM CASTING ALLOYS

The obvious advantage of the M-45 casting alloy, aside from its cryogenic usefulness, is its suitability for applications requiring high toughness over a wide service-temperature range. At cryogenic temperatures, the M-45 alloy is extremely tough; Charpy V-Notch values range between 11 and 25 foot-pounds of impact-absorbing energy for the high-strength material in the T6 condition. Conventional aluminum-casting alloys, such as 195, 220, and 356, are much less tough at both room and low

TABLE 8.—Charpy V-Notch Impact Absorption Energy Data for Selected Aluminum Casting Alloys

Alloy and temper	Energy absorbed in ft-lb at				
	75° F	-5° F	-110° F	-240° F	-320° F
M-45-T6*	14	—	est 16	—	19
195-T4**	4	5	5	—	—
195-T6	2	—	—	2	2
220-T4	6	6	3	—	—
355-T4	2	2	2	—	—
356-T4	2	2	2	—	—
356-T6	1	—	—	1	1
KO-1-T64***	15	—	—	—	—
KO-1-T6	4	—	—	—	—
CH-70-T6	8	—	—	—	—

\* T6 = Solution heat treated plus artificially aged.

\*\* T4 = Solution heat treated.

\*\*\* T64 = Heat treatment unknown but results in low tensile yield strength of 25 ksi.

temperatures. Comparative data are shown in table 8. Relationships of strength and impact toughness between M-45 and selected conventional aluminum casting alloys are illustrated in figure 17.

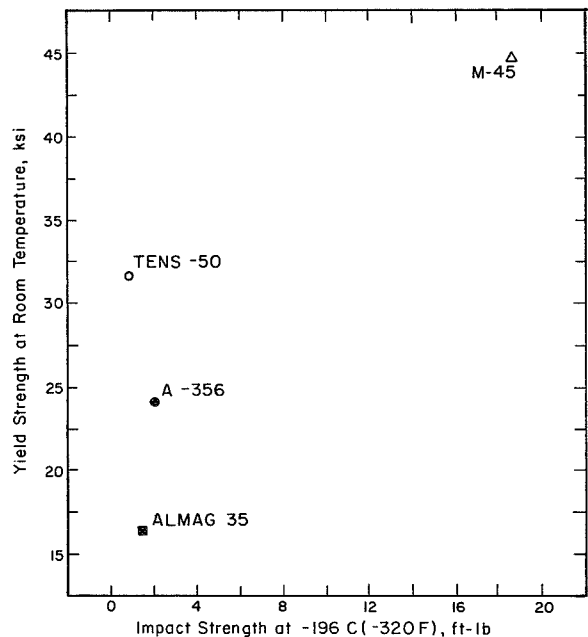

FIGURE 17.—Strength-impact toughness relationships between M-45 and conventional aluminum casting alloys (ref. 12).

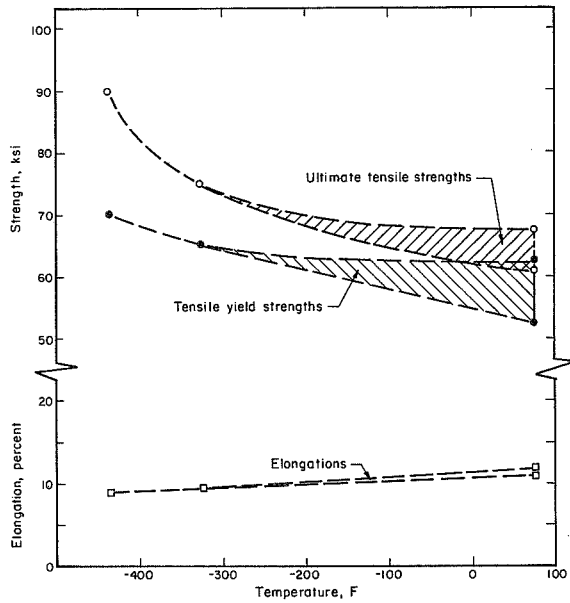

FIGURE 18.—Effect of test temperature on the tensile properties of KO-1 casting alloy in the T6 condition (ref. 17).

The new high-strength aluminum casting alloys, KO-1 and CH-70, which are both of the Al-Cu-Ag-Mg type (typical compositions are: Al-4.75Cu-0.7Ag-0.25Mg-0.25Ti and low content of iron and silicon) might in some ways be competitors of the M-45 alloy. The data in table 8 indicate, however, that the impact toughness of these compositions at room temperature is considerably less than that of the M-45 alloy when they are compared in the T6 condition. Toughness data for the KO-1 and CH-70 alloys at cryogenic temperatures are not available, although it is believed that their toughness would parallel their tensile ductility, which decreases with decreasing test temperatures. The effect of low test temperature on the tensile properties of heat-treated KO-1 alloy castings (T6) is shown in figure 18 (ref. 16). This information may be compared with figure 10, which contains similar data for M-45 alloy.



## Stress Corrosion

The original artificial aging treatment used for M-45 production castings was 16 hours at 325° F (163° C). This heat treatment (T6) was found to be unsatisfactory for the castings because of their susceptibility to stress corrosion. Since most heat-treatable high-strength aluminum-copper alloys display a favorable combination of high strength and resistance to stress corrosion in an overaged condition (T7), a heat treatment consisting of 18 hours at 995° F (535° C), water quench, plus 26 hours at 375° F (190° C) was arbitrarily selected for production castings. This thermal treatment is specified in MSFC-SPEC-470 (A Marshall Space Flight Center specification), and proved satisfactory in eliminating stress-corrosion cracking in production castings (ref. 17).

To determine the heat treatment of M-45 alloy that would give the best combination of high strength and stress-corrosion resistance, a systematic study was undertaken in which

numerous artificial aging treatments were evaluated (ref. 17). These aging treatments were applied to several specimens of the alloy in the form of 1/2-inch-diameter cast bars, which have been previously heat-treated in solution at 990° F. The basic tensile properties obtained under each of the test conditions are set out in table 9. (Five sets of these data are the same as those contained in table 4.) The corrosion and stress-corrosion tests conducted on these samples are described in reference 17;

Threaded-end, round tensile specimens (1/4-inch-diameter with 1/2-inch gage length) were stressed in direct tension in special fixtures to 50 percent and 75 percent of the yield strength of the alloy. An alternate immersion tester containing a 3 1/2 percent sodium chloride solution provided the test medium. This test employed a one-hour cycle in which the specimens were immersed for 10 minutes followed by 50 minutes of drying in the atmosphere above the solution. The test duration was until specimen failure or a 90-day exposure, whichever occurred first. Unstressed duplicate specimens were exposed under identical conditions for control purposes.

TABLE 9.—*Artificial Aging Heat Treatments and Tensile Properties Obtained in These Conditions Screened for Stress-Corrosion Susceptibility*

Artificial aging temperature	Aging time, hours							
	6	8	12	16	18	26*	48	72
350° F (177° C)								
Ultimate tensile strength, ksi							54.4	53.6
Yield strength (0.2% offset), ksi							51.3	50.2
Elongation (% in 2 inches)							2.5	2.8
375° F (190° C)								
Ultimate tensile strength, ksi			55.6	54.0	54.3	54.2		
Yield strength (0.2% offset), ksi			51.9	50.3	49.9	48.8		
Elongation (% in 2 inches)			2.5	2.4	2.5	2.9		
400° F (204° C)								
Ultimate tensile strength, ksi	55.3	53.9	54.4					
Yield strength (0.2% offset), ksi	49.6	49.6	49.0					
Elongation (% in 2 inches)	3.3	2.8	3.0					

\* Specimens aged at 375° F (190° C) for 26 hours represent regular production material, and the value shown is an average from 52 test specimens, representing 13 heats.

TABLE 10.—Room-Temperature Tensile Properties of M-45 Alloy After Solution Heat Treatment (990°F) Plus Artificial Aging and Exposure in Salt Water

Specimens unstressed					Specimens stressed 50% of Y.S.					Specimens stressed 75% of Y.S.			
Time aged, hours	Exposure time, Days	U.T.S., ksi	Y.S., ksi (0.2% Offset)	Elongation, % in ½ in.	Exposure time, days	U.T.S., ksi	Y.S., ksi (0.2% Offset)	Elongation, % in ½ in.	Exposure time, days	U.T.S., ksi	Y.S., ksi (0.2% Offset)	Elongation, % in ½ in.	
Artificially aged at 350° F (177° C)													
48	90	46.6	43.8	5.0	90	46.3	45.0	4.5	90	37.3	36.7	3.0	
	90	49.1	46.8	3.0	90	32.6	32.4	3.0	90	49.7	46.8	3.0	
	26**	52.0	49.5	5.0	90	49.7	45.8	5.5	26*	—	—	—	
72	90	40.4	40.2	3.0	90	44.8	43.6	4.0	90	42.9	***	—	
	90	42.7	42.6	—	90	46.7	45.8	4.0	90	46.8	44.7	4.5	
	81**	46.9	44.2	6.0	90	25.4	***	—	81*	—	—	—	
Artificially aged at 375° F (190° C)													
12	90	47.6	45.8	3.0	90	46.2	44.3	3.0	90	43.0	42.2	3.5	
	90	49.0	45.7	4.5	90	47.7	43.2	5.0	31*	—	—	—	
	31**	51.3	49.0	—	11*	—	—	—	7*	—	—	—	
16	90	44.7	42.9	3.0	90	35.5	***	—	90	48.2	46.4	4.0	
	90	27.7	***	—	90	38.0	37.4	4.0	41*	—	—	—	
	28**	51.6	47.9	0.5	90	48.4	46.0	4.0	28*	—	—	—	
18	90	43.4	42.3	—	90	45.4	44.1	4.5	46*	—	—	—	
	90	45.4	43.7	3.0	90	40.1	38.8	2.0	41*	—	—	—	
	41**	51.5	47.7	5.0	90*	—	—	—	6*	—	—	—	
26	90	43.8	42.4	4.5	90	38.6	37.0	3.0	66*	—	—	—	
	66**	43.3	43.2	5.0	90	47.4	44.4	4.0	21*	—	—	—	
	26**	47.8	46.9	5.0	49*	—	—	—	6*	—	—	—	
Artificially Aged at 400° F (204° C)													
6	90	46.3	44.6	4.5	90	44.8	41.9	7.0	90	45.7	43.2	6.0	
	90	47.3	45.2	3.5	90	42.7	40.6	4.0	26*	—	—	—	
	26**	52.6	47.4	5.0	90	41.6	39.1	4.0	21*	—	—	—	
8	90	48.2	43.4	4.5	90	46.5	44.0	4.0	90	37.9	37.8	4.0	
	90	45.0	42.5	4.0	90	47.6	45.7	7.0	34*	—	—	—	
	34	49.2	46.4	4.0	90	44.2	41.2	4.5	7*	—	—	—	
12	90	49.6	41.8	4.5	90	39.1	38.8	4.0	90	40.5	39.8	4.0	
	90	46.0	43.8	4.0	90	44.3	41.1	4.5	90	39.6	38.8	2.0	
	90	41.0	39.4	3.5	90	36.3	35.4	4.0	90	42.7	39.8	—	

\* Number of days exposed until failure.

\*\* The mechanical properties of the unstressed specimen were determined after indicated exposure time (days).

\*\*\* Specimens fractured before yield point could be obtained during tensile testing.

Test Data:

- a. Specimens: Threaded end tensile specimens (2 in. long by ¼ in. diameter) representing 4 heats.
- b. Medium: Alternate immersion in 3½ percent salt solution.
- c. Exposure time: Until failure or 90 days.



The length of time, in days, for the stressed specimens to fracture was recorded. At the time of fracture, the duplicate unstressed specimen was removed, and the mechanical properties were obtained to determine if the failure was one of general corrosion rather than due to stress corrosion cracking. General corrosion would result in a gradual reduction of the effective cross-sectional areas of both the stressed and unstressed specimens. The mechanical properties obtained from the unstressed specimen (based on the original cross-sectional area) were compared to the original mechanical properties. From this comparison, the decrease in mechanical properties due to general corrosion of the unstressed specimen could be determined. The mechanical property comparisons indicated that all failures which occurred before the end of the 90-day exposure test period were the result of stress corrosion cracking; also, metallographic examinations of some specimens indicated that failure was due to intergranular stress corrosion cracking. The rate of incidence of this type failure was more prevalent for material artificially aged at 375° F. (190° C) than for material artificially aged at 350° F. (177° C) or 400° F. (204° C); also, specimens stressed at 75 percent of yield strength tended to fail more frequently during the exposure period than specimens stressed at 50 percent of yield. Specimens that were stressed at 50 percent of yield strength and exposed for 90 days without failures were from material artificially aged at (1) 350° F. (177° C) for 48 hours and 72 hours; (2) 375° F. (190° C) for 16

hours; and (3) 400° F. (240° C) for 6, 8, and 12 hours. The only specimens, stressed at 75 percent strength, which did not show failures through the 90-day exposure period were those artificially aged at 400° F. (204° C) for 12 hours.

After the tests were terminated, the mechanical properties were determined for the stressed specimens that had not failed and their corresponding unstressed specimens. There was no significant difference between the final mechanical properties of the stressed and unstressed specimens. General corrosion had caused approximately a 20 percent strength reduction from the original mechanical properties in both stressed and unstressed specimens.

Regarding the test procedures discussed above, reference 18 gives detailed descriptions of the specimen configurations, special fixtures, loading techniques, and areas to which protective coatings were applied. The mechanical properties finally determined by the tests of both the stressed and unstressed specimens are shown in table 10. It was concluded from this investigation that the optimum artificial aging treatment for the M-45 alloy is 12 hours at 400° F. (204° C). After this treatment the alloy appears to have the most favorable combination of high strength and resistance to stress-corrosion cracking.



## Conclusions

Although the original NASA requirements for the development of the M-45 alloy specified that the material should perform well at cryogenic temperatures, no applications of the material for such uses have yet been made. The configurations cast with this material have been very limited in number, but some of them have been so varied in shape and geometry that they have been difficult to cast.

As indicated previously, a few castings of the alloy were fabricated for ground-support equipment used in early Saturn launchings. These castings were not life-supporting pieces of hardware, but they were cast to meet the same requirements of quality as those specified for man-rated equipment. X-ray inspection of each casting revealed all of this hardware to be 99.9% defect-free; the same quality assurance as that required for flight hardware. To achieve this standard of quality, a few changes in pattern design were necessary to reduce stress concentrations, and thus enable the foundry at Redstone Arsenal, Alabama, to meet the requirement satisfactorily. Most of the equipment in which the M-45 alloy was used initially is now obsolete because of changes in the design of major ground-support systems. A few of the original M-45 castings, however, are still in service for the support of Saturn launchings.

A few configurations of castings made with M-45 alloy are listed showing the range in the size and complexity of typical items and uses to which they may be applied. In general, the discussions and illustrations that follow indicate that the range in weight for these items is from about 1 pound to more than 60 pounds, and the range in size, from about 4 × 6 inches × thickness to over 20 × 40 inches × thickness, with section variations between 0.3 inch and 3.0 inches.

1. An experimental pump housing with an internal spider has a minimum wall thickness of 0.02 inch. The design of this pump with gates and risers is shown in figure 19. Other views of the same device are shown in figure 7.

2. A cam link weighing about 1 pound, is the smallest part cast from M-45 alloy. It was designed for use in a fuel-disconnect device. Its outside dimensions are about 4 × 6 inches with a maximum section thickness of about 1 inch.

3. T cast bracket weighing about 3 pounds and with outside dimensions of 6 × 6 × 8 inches, is shown in figure 20. The minimum section thickness of this casting is about 0.3 inch; the maximum, about 0.9 inch.

4. A housing for a separation mechanism weighing 8 pounds and with outside dimensions of 6 × 6 × 10 inches, is illustrated in figure 21. This casting has a base 0.75-inch thick and walls 0.38-inch thick. Prior to a

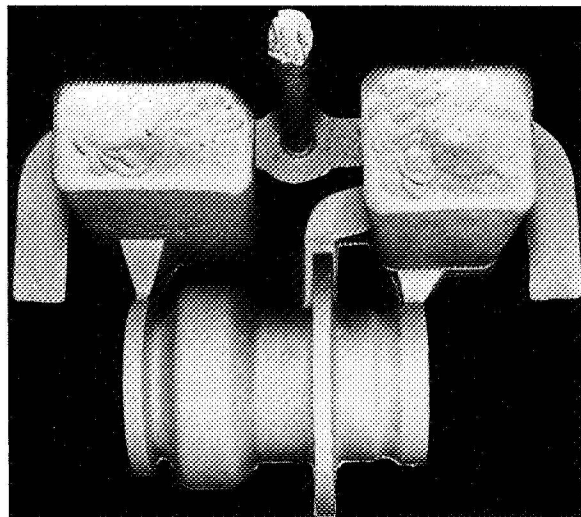

FIGURE 19.—Top oblique view of pump housing with gates and risers attached.

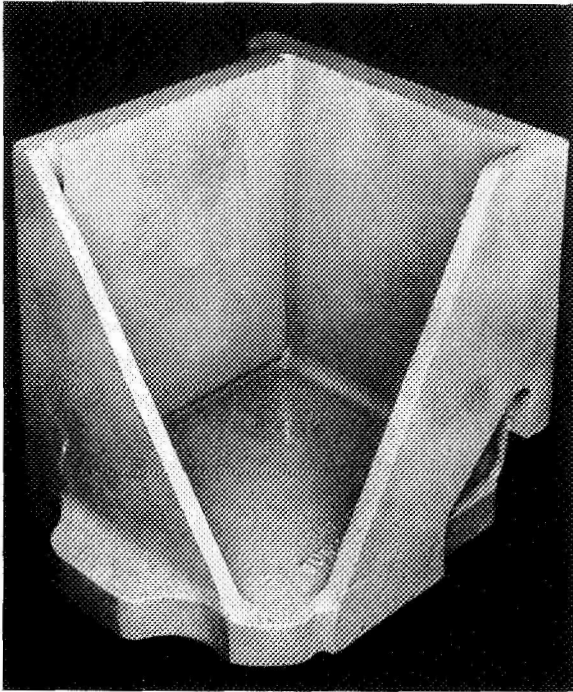

FIGURE 20.—Sand cast bracket weighs 3 pounds; 6×6×8 inches OD.

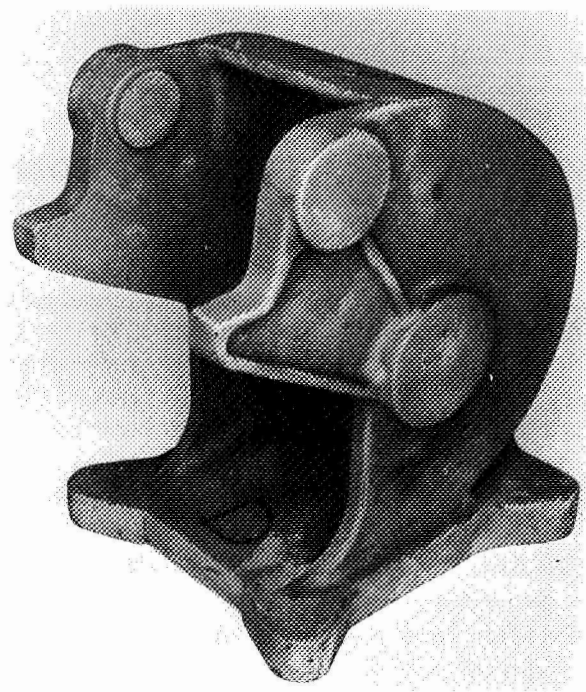

FIGURE 21.—Separation mechanism housing cast with M-45 alloy weighs 8 pounds; 6×9×10 inches OD.

modification of boss design, some difficulties in producing defect-free castings in this configuration were experienced.

5. An instrument shelf is shown in figure 22. This casting has outside dimensions of 27 × 12

× 4 inches, and a finished weight of 24 pounds. This item is one of the production castings of the M-45 alloy that must have high toughness, but not necessarily a capability to withstand cryogenic temperatures.

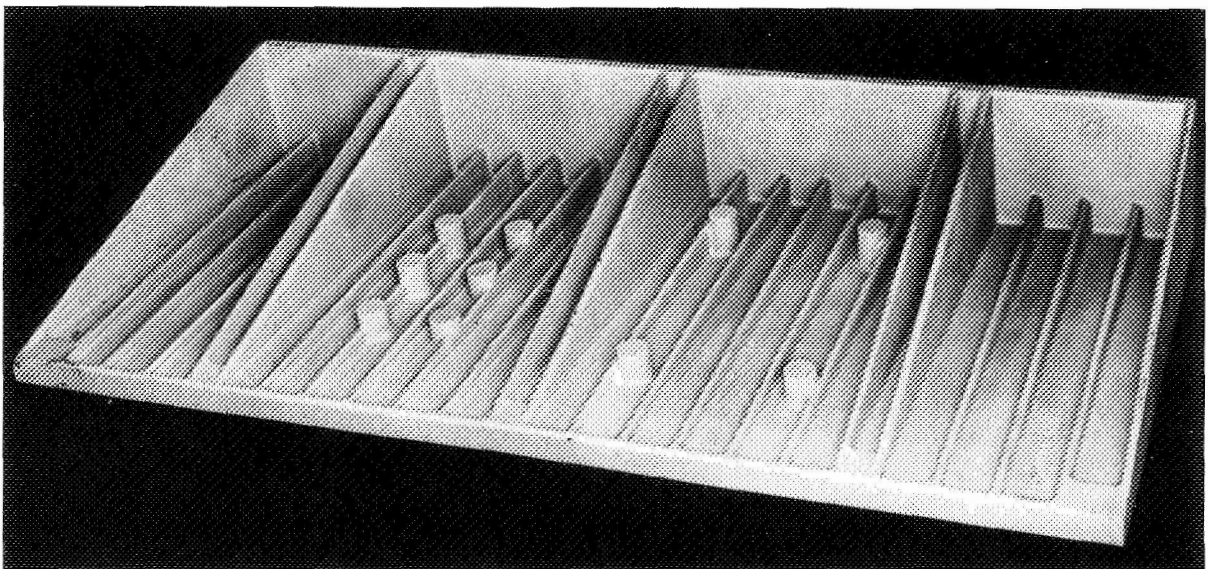

FIGURE 22.—Sand cast instrument shelf weighs 24 pounds; 27×12×4 inches OD.



6. A fuel nozzle disconnect bumper, known officially as Bumper Casting LH<sub>2</sub> Withdrawal Mechanism, is shown in figure 23. It has a finished cast weight of 64 pounds and outside dimensions as indicated. The section thickness of the thin web areas is 0.38 inch, and the maximum section thickness is about 3 inches. This casting is used in the assembly that catches the liquid-hydrogen-fueling nozzle at the time of fuel-nozzle disconnect from Saturn 5. Since the nozzle returns to the bumper, or catcher, assembly at high speed, the casting must have high resistance to impact. The service record of the three castings still in active service for Saturn 5 was unmarred after five launches. All of the castings survived the high-impact loading of the operation, which tends to verify the extreme toughness of the M-45 alloy.

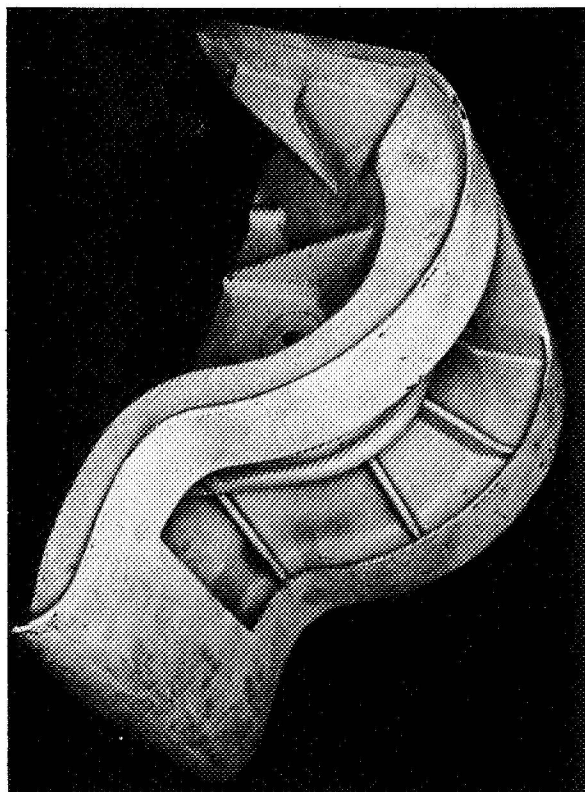

FIGURE 24.—Bumper casting, M-45 alloy.

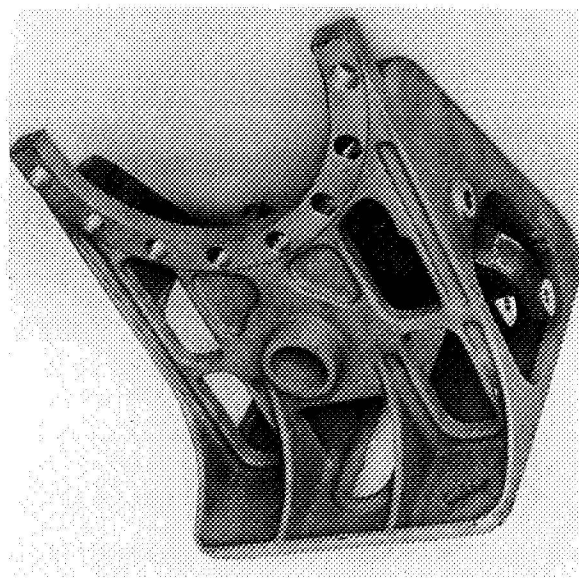

FIGURE 25.—Propellant line bracket assembly, M-45 alloy.

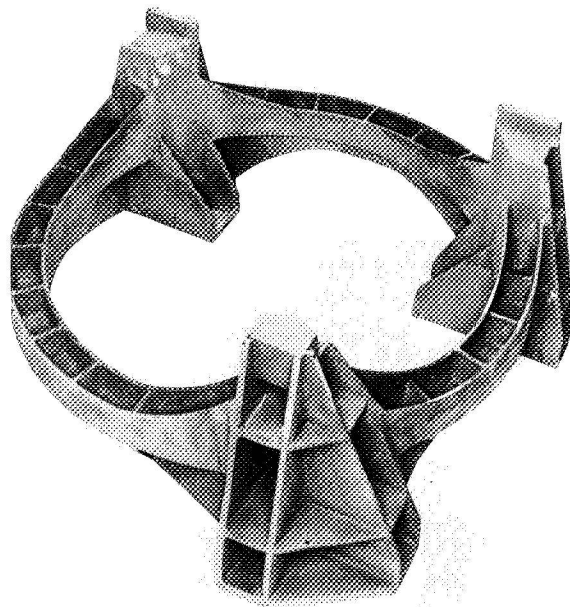

FIGURE 26.—Gyro stabilizer support bracket, M-45 alloy.

A photograph of a bumper casting of earlier design, showing some of the details of ribs and webs, is presented in figure 24. The propellant-line bracket of figure 25, and the gyro-stabilizer support bracket of figure 26 also

illustrate the intricate casting designs that are possible with M-45 casting alloy.

Based on the information discussed in this report, it is concluded that the M-45 aluminum casting alloy has a unique combination of excellent ambient- and cryogenic-temperature toughness and moderate-to-high tensile strength. When the material is heat-treated to its highest strength level, stress corrosion problems are encountered; however, limited data support the conclusion that stress corrosion can

be overcome by overaging, and, at the same time, very useful mechanical properties can be retained (e.g., tensile yield strength of nearly 50,000 psi). Additional studies would be beneficial in finding better definitions of the alloy's properties, and in determining the influence of heat treatment on these properties. The alloy can be used effectively in a variety of applications in which materials of exceptional toughness and moderately high strength are required.

## References

1. WILLIAMS, D. N.; WOOD, R. A.; AND OGDEN, H. R.: Development of Aluminum Castings with High Impact Strength at Low Temperatures. Summary Report on Contract NAS 8-1689, Marshall Space Flight Center, June 1962.
2. WILLIAMS, D. N.; WOOD, R. A.; AND OGDEN, H. R.: Development of Aluminum Castings with High Impact Strength at Low Temperatures. NASA CR-58, June 1964.
3. U.S. Patent, 3,347,665, Oct. 1967.
4. OSWALT, K. J.: Evaluations of Processing Techniques for Producing Premium Quality, High Strength Aluminum Alloy Castings. AFML-TR-68-8, Dec. 1968.
5. HARDY, H. K.: The Effect of Small Quantities of Cd, In, Sn, Sb, Tl, Pb, or Bi on the Aging Characteristics of Cast and Heat Treated Al-4Cu-0.5Ti Alloy, *J. Inst. Metals*, Vol. 78, 1950-1951, p. 169.
6. HARDY, H. K.: The Solid Solubilities of Cd, In, and Sn in Aluminum. *J. Inst. Metals*, Vol. 80, 1951-1952, p. 431.
7. HARRY, H. K.: The Aging Characteristics of Ternary Aluminum-Copper Alloys with Cd, In, or Sn. *J. Inst. Metals*, Vol. 80, 1951-1952, p. 483.
8. POLMEAR, I. J.: The Effect of Small Additions of Silver on the Aging of Some Aluminum Alloys. *Trans. of the Met. Soc. of AIME*, Vol. 230, Oct. 1964.
9. LOVOY, C. V.: Heat Treatment Study of Aluminum Casting Alloy M-45. Internal note IN-P&VE-M-67-1, Marshall Space Flight Center, Jan. 1967.
10. RAYNOR, G. V.: Annotated Equilibrium Diagram Series, no. 4, *Inst. Metals (London)*, 1944.
11. MILLER, P. C.: Metallurgical Evaluation of a New Aluminum Casting Alloy Developed for Space Vehicle Use at Cryogenic Temperatures. NASA TM X-53114, Marshall Space Flight Center, Aug. 1964.
12. ROSENBERG, S. J.: Effect of Low Temperatures on the Properties of Aircraft Metals. Research Paper RPI347, *J. Res., National Bureau of Standards*, Vol. 25, no. 6, Dec. 1940, pp. 673-701.
13. PETTY, P. B.: Memorandum on Subzero Application for Aluminum. Hydrocarbon Research Inc., (New York City), Oct. 1944.
14. ANON: Case Histories; Applications of KO-1 Aluminum Alloy Castings. Electronic Specialty Co., Pomona Div., Feb. 1969.
15. Aluminum Alloy KO-1 for High Strength, Premium Quality Castings. Smithford Products Co., (Ontario, California), Feb. 1969.
16. Compilation of information from: (a) ANON: Laboratory Memorandum; Cryogenic Properties of New High Strength Aluminum Casting Alloys. North American Aviation, Inc., Space and Information Systems Divisions, Oct. 1966. (b) ANON: Office Memorandum; Evaluation of Aluminum Casting Alloy KO-1. AiResearch Mfg. Co. of America, Aug. 1968. (c) ROSNER, J. L.: Cast KO-1 Aluminum Alloy. Technical Data Report No. AW 0200-030, Allison Division, GMC, Oct. 1968.
17. LOVOY, C. V.: Stress Corrosion Characteristics of Aluminum Casting Alloy M-45. IN-P&VE-M-68-2, Marshall Space Flight Center, March 1968.
18. HUMPHRIES, T. S.: Procedures for Externally Loading and Corrosion Testing Stress Corrosion Specimens. NASA TM X-53483, June 1966.

NATIONAL AERONAUTICS AND SPACE ADMINISTRATION  
WASHINGTON, D. C. 20546  
OFFICIAL BUSINESS

FIRST CLASS MAIL



POSTAGE AND FEES PAID  
NATIONAL AERONAUTICS AND  
SPACE ADMINISTRATION

POSTMASTER: If Undeliverable (Section 158  
Postal Manual) Do Not Return

---

*"The aeronautical and space activities of the United States shall be conducted so as to contribute . . . to the expansion of human knowledge of phenomena in the atmosphere and space. The Administration shall provide for the widest practicable and appropriate dissemination of information concerning its activities and the results thereof."*

— NATIONAL AERONAUTICS AND SPACE ACT OF 1958

## NASA TECHNOLOGY UTILIZATION PUBLICATIONS

These describe science or technology derived from NASA's activities that may be of particular interest in commercial and other non-aerospace applications. Publications include:

**TECH BRIEFS:** Single-page descriptions of individual innovations, devices, methods, or concepts.

**TECHNOLOGY SURVEYS:** Selected surveys of NASA contributions to entire areas of technology.

**OTHER TU PUBLICATIONS:** These include handbooks, reports, notes, conference proceedings, special studies, and selected bibliographies.

Technology Utilization publications are part of NASA's formal series of scientific and technical publications. Others include Technical Reports, Technical Notes, Technical Memorandums, Contractor Reports, Technical Translations, and Special Publications.

*Details on their availability may be obtained from:*

*Details on the availability of these publications may be obtained from:*

**National Aeronautics and  
Space Administration  
Code UT  
Washington, D.C. 20546**

**National Aeronautics and  
Space Administration  
Code US  
Washington, D.C. 20546**

**NATIONAL AERONAUTICS AND SPACE ADMINISTRATION**  
Washington, D.C. 20546