



P. O. BOX 11276 ◻ RALEIGH ◻ NORTH CAROLINA 27604 ◻ (919) 876-2313

RESEARCH CONTRACT NAS1-9398
TESTING AND FABRICATION OF
PLASTIC VACUUM PROBE SURFACE SAMPLERS

FINAL REPORT

NATIONAL AERONAUTICS AND SPACE ADMINISTRATION

PERIOD COVERED: June 30, 1969 to July 10, 1970

G. Briggs Phillips, Ph.D.
Project Officer



Mathew L. Petrovick
Assistant Project Officer

TABLE OF CONTENTS

ABSTRACT-----	i
I. INTRODUCTION-----	1
II. TECHNICAL APPROACH-----	1
A. Design Criteria-----	1
B. Initial Design Concepts-----	3
C. Molded Vacuum Probe Sampler Concept-----	8
D. Mold Design and Fabrication-----	9
1. Vacuum Probe Mold Description-----	10
E. Microbiological Test Results-----	10
F. Sterilization Methods and Procedures-----	13
G. Air Flow Characteristics of the Vacuum Probe Sampler-----	15
H. Delivered Items-----	16
I. Packaging and Disposable Cones-----	19
III. OPERATING USE AND INSTRUCTIONS-----	19
IV. CONCLUSIONS-----	21
APPENDIX-----	22

ILLUSTRATIONS

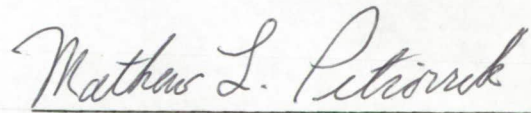
Figure 1	-	Threaded Head and Cone Assembly-----	4
Figure 2	-	Bayonet Twist-Lock Head and Cone Assembly-----	5
Figure 3	-	Tapered-Lock Design-----	6
Figure 4	-	Air Flow Diagram-----	17
Figure 5	-	Saturation Chart-----	18
Figure 6	-	Major Assembly of Head and Cone-----	28
Figure 7	-	Retaining Ring and Probe Head-----	29
Figure 8	-	Side View, Detailed Dimensions of Cone Assembly---	30
Figure 9	-	Probe Cone and Teflon Tip Insert Detail-----	31
Figure 9a	-	Retaining Ring and Handle Detail-----	32
Figure 10	-	Cone Assembly Mold-----	33
Figure 11	-	Head and Retaining Ring Assembly Mold-----	34

ABSTRACT

Based on the workscope of the subject contract, a moldable plastic vacuum probe surface sampler has been designed and fabricated. The design provides an economical sampler for determining the microbial population of surfaces. The unit is lightweight, less expensive than the metal fabricated items and a sampler that utilizes a sterilized disposable cone assembly.

Microbiological tests demonstrate that the performance of the molded plastic vacuum probe is equivalent to that of other similar devices for removal of normally occurring floor contamination.

I. INTRODUCTION

The Becton, Dickinson Research Center of Raleigh, North Carolina entered into a contract with NASA on June 30, 1969 for the purpose of testing and fabrication of plastic Vacuum Probe Surface Samplers. The objective of the contract was to develop a new design approach for mass production of sterile plastic disposable surface samplers based on the previous aluminum design produced by Sandia Corporation of New Mexico.

Part of the development program was concerned with the selection of optimal concepts (reusable vs. disposable) and methods of fabrication. Verification of the microbiological recovery of new vacuum probe surface samplers formed part of the overall objective of this contract.

Due to the interdisciplinary nature of the workscope, the contract efforts carried out were performed jointly by the Biomedical Engineering and Microbiological Sciences Departments of the Research Center.

II. TECHNICAL APPROACH

The initial contract effort involved literature review and investigations into the development of the original Vacuum Probe Surface Sampler by Sandia Corporation. A Sandia Vacuum Probe was obtained and studied in detail along with various design reports. Based upon these baseline references, the project team developed and evaluated several design concepts in order to select the final approach.

A. Design Criteria

In the development of new design approach, the following criteria were considered:

1. Fabricate the entire Vacuum Probe Surface Sampler from a thermo-stable plastic that could withstand repeated steam sterilization.
2. Design a disposable or replaceable sampling nozzle.
3. Design and fabricate one-use disposable components.
4. Design a unit for aseptic handling that prevents contamination by operator.
5. Design a method of holding the head and cone assembly together which provides quick disconnect without contamination of cone.
6. Design a method which facilitates handling the sampling filter to maintain sterility of samples.
7. Consider an economical, easy to fabricate design.
8. Consider factors of sterility and disposability into the design as a means of simplifying use and maintenance of the vacuum probe sampler.
9. Evaluate materials for possible toxic or inhibitory properties and the relationship to fabrication of vacuum probe surface samplers.
10. Evaluate various methods for sterilization including steam under pressure, ethylene oxide or formaldehyde and select a specific approach.

B. Initial Design Concepts

During the design process for the surface sampler, particular attention was focused upon the basic mechanical design of the head, cone, and nozzle assembly. Previous designs, although quite functional, had operational limitations. The methods of attaching the head and cone assembly with a "C" clamp, knurled knob and mechanical pressure were considered as disadvantageous. Furthermore, the required handling increased the possibility of contamination by the user.

The following designs were considered as improvements in the basic design of the vacuum probe:

1. Threaded head and cone assembly.
2. A bayonet twist-lock head and cone assembly.
3. A tapered-lock design.

Figures 1 to 3 illustrate these concepts of the early design stages.

Evaluation of these design approaches revealed a variety of advantages and disadvantages for each concept relating to handling, sterilization, fabrication problems, cost, and user problems. The most advantageous was the tapered-lock design. In order to examine this concept more fully, a hand-made vacuum probe sampler was constructed for design evaluation of the locking mechanism.

The basis of operation of the tapered-lock relies on a male/female taper of 15° at the head and cone. By careful control of the mechanical tolerances, both the head and cone are compressed against an "O" ring forming an airtight seal. The mock-up was examined for air leaks and mechanical

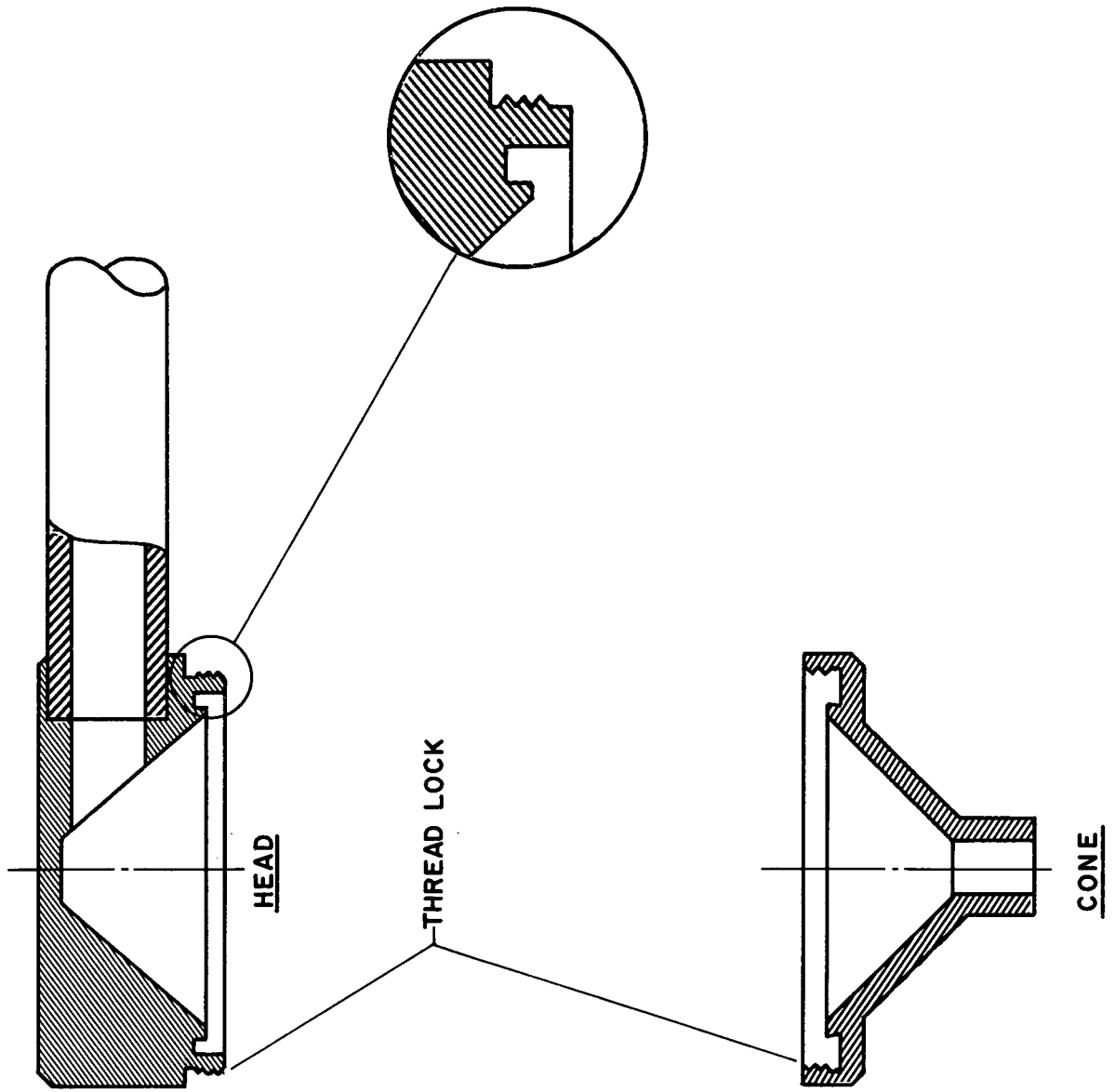

Figure 1

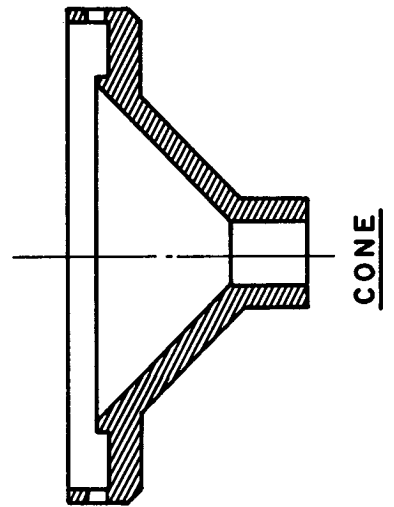
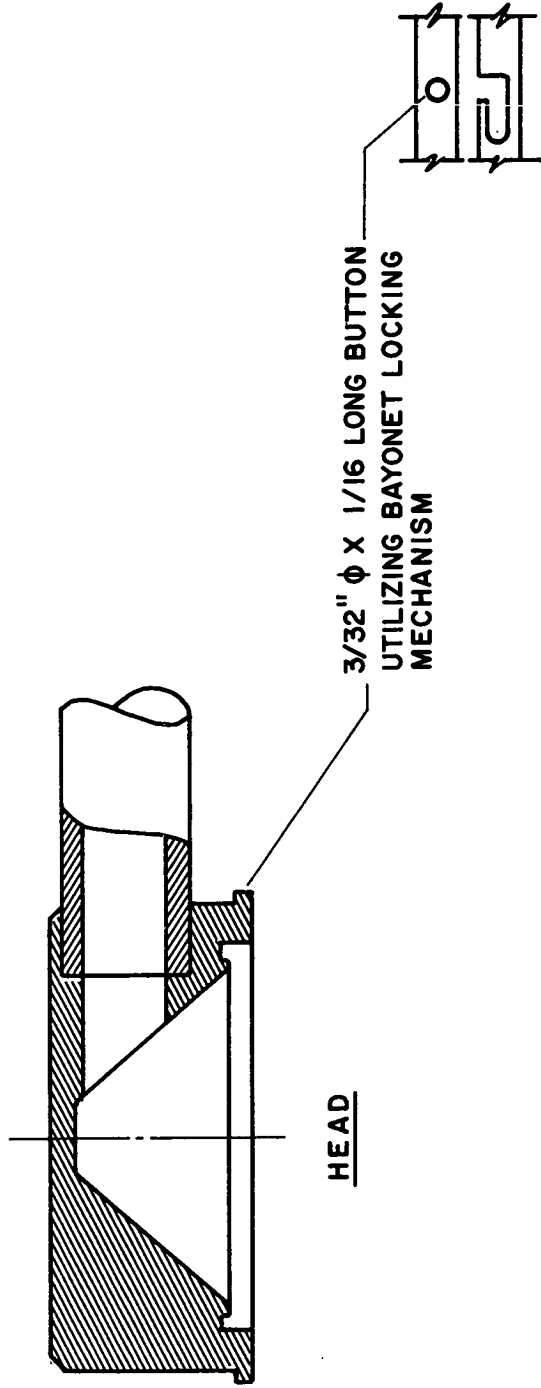

Figure 2

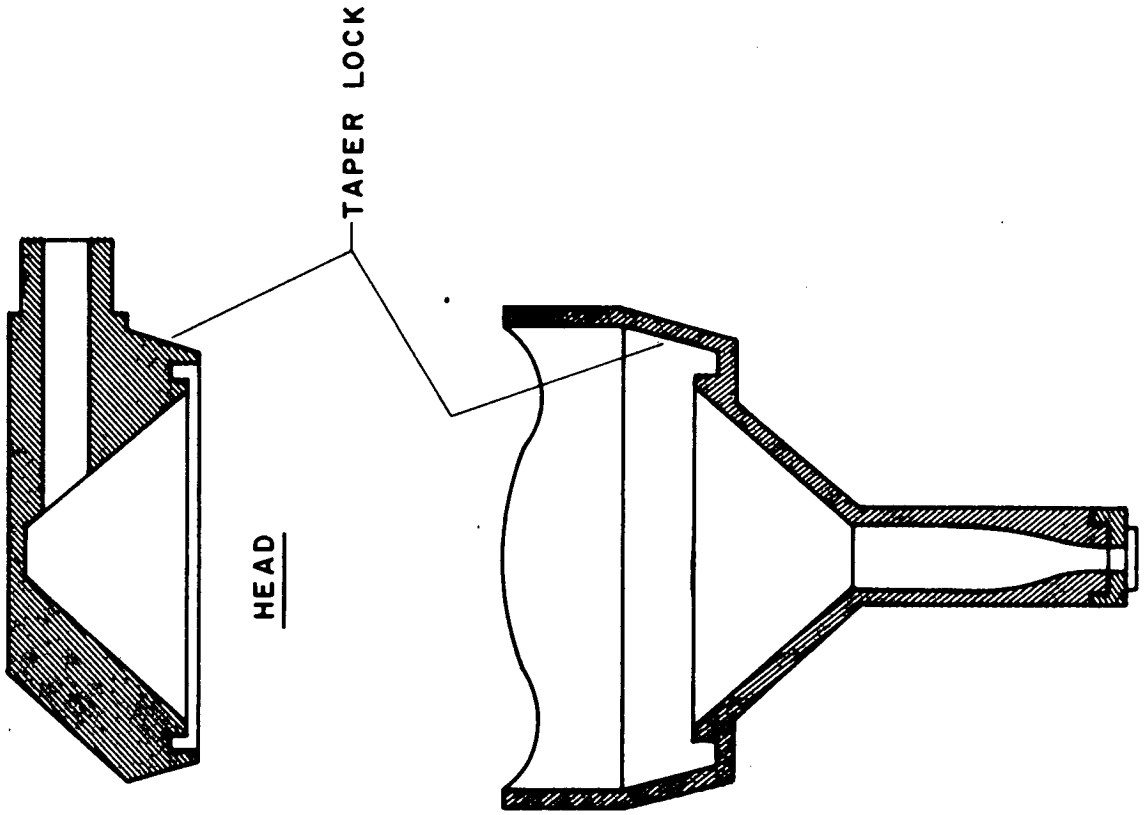

Figure 3

CONE

HEAD

TAPER LOCK

holding ability, particularly when subjected to lateral forces such as during "bumping". The holding ability withstood this test well and the cone was not dislodged from the head after repeated lateral blows. Based upon the results of the handmade model, a decision was made to follow the tapered-lock design. A final paper design of the tapered-lock was made which would employ a molded head and cone assembly. By molding the head and cone assembly, considerable cost savings and aseptic handling features are possible. The following advantages are available with this design:

1. The probe cone can be provided in a pre-packaged, sterile and disposable form.
2. The probe head and handle unit is reusable, resulting in cost savings.
3. The device can be assembled or disassembled without contaminating the probe cone.
4. The device is easy to seal without mechanical clamps, knobs, twist locks, bayonet connectors and other complicated mechanical holding techniques.
5. An optional feature of a teflon nozzle tip permits use in optical surface sampling when required.
6. The unit is light weight and easy to handle, thereby reducing user fatigue.
7. The economy of the molded design approach will permit expansion of the probe in new applications of surface sampling in the field of environmental microbiology.

C. Molded Vacuum Probe Sampler Concept

Based on the early evaluation and design phase of the subject contract, it was concluded that the best possible design configuration was tapered-lock fit acquired by a plastic molded vacuum probe sampler.

As the design factors, disposability, sterility and user considerations were formulated, a sterile disposable cone became the key feature of the final design. However, a major problem developed in the user handling of the cone and nozzle assembly. It was felt from the microbiological standpoint that the ideal approach should not permit the operator to touch the cone during disassembly after sampling. To overcome this problem, it was necessary to eliminate any clamps, knobs or general handling. This objective was accomplished by the BDRC design based on a "tapered-lock" design and "tripod cone" assembly. The head assembly and the cone assembly have been designed to accomplish mechanical attachment via the tapered-lock. Figures 6-8 illustrate the design concept. The basis of holding the head and cone assembly together is dependent on rather carefully controlled tolerances in the plastic molded parts. The holding power of the two halves is integrally dependent on the fit and durometer of the "O" ring seal in the cone and head assembly. Once the stainless steel mesh screen, retaining ring and Gelman filter are assembled, the head and cone assembly are mechanically snapped together creating compression on the "O" ring and adjacent tapered surfaces. By insuring tight manufacturing tolerances, both the head and the cone snap into a lock position without knobs, clamps or mechanical devices.

The separation of the head and cone assembly initially presented a problem in that one normally would remove them by hand. However, the unique feature of the BDRC design employs a "raised tripod" configuration. (See Figure 9).

The removal of the cone from the head simply requires that the operator invert the cone and nozzle assembly and gently tap the cone tripod on a flat surface. The slight force created by this procedure is sufficient to release the cone from the head. The operator can then remove the cone and the filter aseptically and proceed with the culturing process. The process of inverting the cone also provides easy access to the filter located on the mesh screen once the cone has been removed. By this method, the filter is available in the "filter up" position. The side of the filter containing the sampled microorganisms is facing up and facilitates easy transfer of culture.

D. Mold Design and Fabrication

Once the basic moldable vacuum probe design was established, a problem was encountered in locating a source for mold design and fabrication. The BDRC efforts in locating a source to develop and process the molds involved several requests for quotes in the north, midwest, northeast, south and southeastern parts of the country. Most organizations refuse to quote on the design because of limited quantity and tight mechanical tolerances. The lack of response from various mold organizations created somewhat of a delay in the program. Of the limited replies received on the quotes, only one company, Alliance Carolina Tool and Mold Company of Arden, North Carolina, appeared to be qualified. Two site visits were made to Alliance to review facilities and general capabilities. The site visits made indicated that this company had the best facilities, tools, equipment, personnel and price to perform the needed task. A B-D purchase order in the amount of \$12,353.75 was awarded with a delivery schedule of 8 to 12 weeks from receipt of order. (The cost of the molds was paid by Becton, Dickinson and Company and not charged to the contract.) The delivery schedule was compatible with the contract delivery date.

1. Vacuum Probe Mold Description

The mold is comprised of one dual cavity D.M.E. Corporation standard mold base 9 7/8" x 20". A cam action design mold was fabricated for the probe head and retaining ring. The probe cone mold is based on a single cavity D.M.E. stripper plate mold base 10 7/8" x 11 7/8". The cam action for the head was necessary due to the internal base and the need to match the inside diameter of the handle. The cam action mold also facilitates high production, low cost manufacturing of the component parts. Each component produced by the molds is made by the mold insert concept, which permits varying the configuration of the cone or head assembly. The mold design incorporates various inputs for controlling temperature of the molds during the processing as a means of sizing the head and cone to the proper fit.

Major features of the mold design are the carefully held material tolerances. Only by careful temperature control of the mold, flow rates of the polystyrene material and the cycling time, is it possible to produce the desired head and cone assembly. Variations in material or mold temperatures results in incompatible mechanical fitting of the head and cone assembly.

E. Microbiological Test Results

The microbiological testing consisted of a comparison of the B-D vacuum probe to the Sandia vacuum probe for microorganism recovery. Microorganisms occurring as normal contamination on a tile floor were used as the test organisms. The tile floor was composed of tile blocks 9 inches square.

Test materials, sampling procedures and filter assay used are listed below:

1. B-D vacuum probe long nose cone - teflon and polystyrene tip.
2. Sandia vacuum probe short nose cone - teflon tip.
3. Gelman filter media 0.45 μ pore size.
4. Vacuum source 1 CFM Gast Electric vacuum pump.
5. Sampling procedure
 - a. Five tile squares sampled per vacuum probe per test procedure.
 - b. Vacuum probe movement from bottom to top of squares twenty times and side to side of squares twenty times.
 - c. Sampling time: 3 minutes.
6. Biological assay consisted of aseptically removing the filter media from the vacuum probe to culture media for appropriate dilutions and plating procedures. The probe cone interior was not assayed for microorganisms.

Microorganism recovery using the modified long nose cone B-D probe and the short nose cone Sandia probe is shown in Table I. In both the test procedures, the Sandia probe recovered more microorganisms than did the B-D probe. The difference in organism recovery of trial one was greater than in trial two, but within a 30% range of the Sandia probe recovery. This recovery difference between the two probes can probably be attributed to the polystyrene material which may be influenced by a static charge characteristic. It was noted during testing that sampling material collected had

TABLE I

Microorganism recovery from Normal Floor Contamination using the B-D Long Nose Cone Sampler and the Sandia Short Nose Cone Sampler

Testing Unit ^{1/}	Microorganisms Recovered Per Tile Square Tile #					Average Organism Recovery Per Tile Square
	1	2	3	4	5	
<u>Test Trial One</u>						
B-D Probe Teflon tip	1500	2500	5200	4200	5100	3700
Sandia Probe Teflon Tip	5100	6600	6000	6000	5200	5780
<u>Test Trial Two</u>						
B-D Probe Teflon tip	3400	1600	22600	3800	700	6420
B-D Probe Polystyrene tip	7800	900	6200	5200	3700	4760
Sandia Probe Teflon tip	600	3300	15600	2600	10600	6540

^{1/} Test trials number one - average vacuum force 12 inches of Mercury

^{2/} Test trials number two - average vacuum force 12 inches of Mercury

^{1/} The average vacuum force was 12 inches of Mercury for each test trial

adhered to the B-D probe long cone interior area. This material collection was not noted with the short nose cone of the Sandia Probe. A previous comparative testing of the original short nose cone version of the B-D probe to the Sandia probe showed no excessive collection of material on the cone nose interior, which resulted in increased microorganism recovery rates (Table II).

It is conceivable that the long nose cone and static charge characteristic of polystyrene may collect microorganisms in the nose cone area and not allow them to reach the filter media. Therefore, it is recommended that the cone interior be assayed for complete organism recovery. It is anticipated that variation of the available vacuum and/or operator handling procedures can drastically change the recovery percentage of the vacuum probe. Adequate training of personnel and use of constant vacuum sources must therefore be employed.

F. Sterilization Methods and Procedures

The procedure employed for sterilizing the vacuum probe cones involved a chemical process using formaldehyde gas. The mechanism for formaldehyde gas production was paper impregnated with paraformaldehyde and used as an insert within a polyethylene bag housing the probe cone assembly. Sterilizing formaldehyde gas was evolved from the paper inside the probe package using a temperature-time exposure cycle of 45C for 25 hours.

Two different biological spore indicators were used for sterility testing. The sterility test procedures and sterilization method was reviewed and approved by the corporate Biological Safety and Control Department of Becton, Dickinson and Company. The use of both 1×10^5 Bacillus stearothermophilus and 1×10^6 Bacillus globigii spore strips was considered to

TABLE II

Microorganism Recovery from Normal Floor Contamination Using the Original
B-D Short Nose Cone Sampler and the Sandia Short Nose Cone Sampler

Testing Unit ^{1/}	Microorganisms Recovered Per Tile Square Tile #					Average Organism Recovery Per Tile Square
	1	2	3	4	5	
B-D Probe Teflon tip	1900	500	900	1000	2000	1260
Sandia Probe Teflon tip	1400	1200	600	600	1100	980

^{1/} Average vacuum force 12 inches of Mercury

be an extremely stringent test of the sterilization capability of the ALDESTERI paper. There were ten sterility test packages for B. stearo-thermophilus and ten B. globigii identical to the other probe cone packages. The recovery assay procedure employed included the use of trypticase soy broth with incubation of B. stearothermophilus at 60C and B. globigii at 37C. At the completion of 72 hours incubation with no evidence of microbial growth in the assay tubes, the product was considered sterile and released. The control spore samples exposed to the same test condition without ALDESTERI paper showed test spore growth after 24 to 48 hours incubation.

The probe package specifications were as follows:

1. Polyethylene bag
 - a. Size O.D. - 5 5/8 x 6 inches
 - b. Inside volume (liquid) - .61 liters fully inflated

G. Air Flow Characteristics of the Vacuum Probe Sampler

Vacuum force created through the Sandia or the B-D vacuum probe sampler is regulated by the flow of air (CFM) that is generated from a vacuum source. With an increase in air flow through an orifice more vacuum force is created. The air flow can be increased to a point of critical velocity or maximum air flow that a particular orifice can carry. The point of critical velocity may be termed the saturation point of air flow for a given orifice which creates a maximum vacuum force for that orifice.

The B-D vacuum probe with a 0.010" orifice was tested to determine the critical air flow level or saturation point for that orifice. The vacuum probe was connected to a vacuum source, air flow meter, and a manometer to

determine the critical velocity as shown in Figure 4. Maximum air flow for 0.010" orifice was reached at 2CFM air flow with filter membrane in the vacuum probe and probe nozzle against a stainless steel surface. Figure 5 shows the vacuum curve to the point of maximum air flow and vacuum force. The 2 CFM represents maximum air flow that can travel through the 0.010" orifice yielding 20.8 inches of vacuum force. With an increase in orifice size, more air flow would be needed to achieve 20.8 inches of vacuum, or a decrease in orifice size would require less air flow to yield 20.8 inches of vacuum. Also, it is noted that at different barometric pressures the vacuum force will change for a given air flow rate. It is recommended that a daily check on barometric pressure from the local airport or weather station be checked and incorporated into any test results of the vacuum probe sampler.

H. Delivered Items

The items delivered on this contract comprise the following components which make up the plastic vacuum probe surface sampler.

1. 50 cones with teflon tips and "O" rings (nonsterile).
2. 5 handles and head assemblies with 150 cones (nonsterile).
3. 30 handles and head assemblies.
4. 960 sterilized cones.

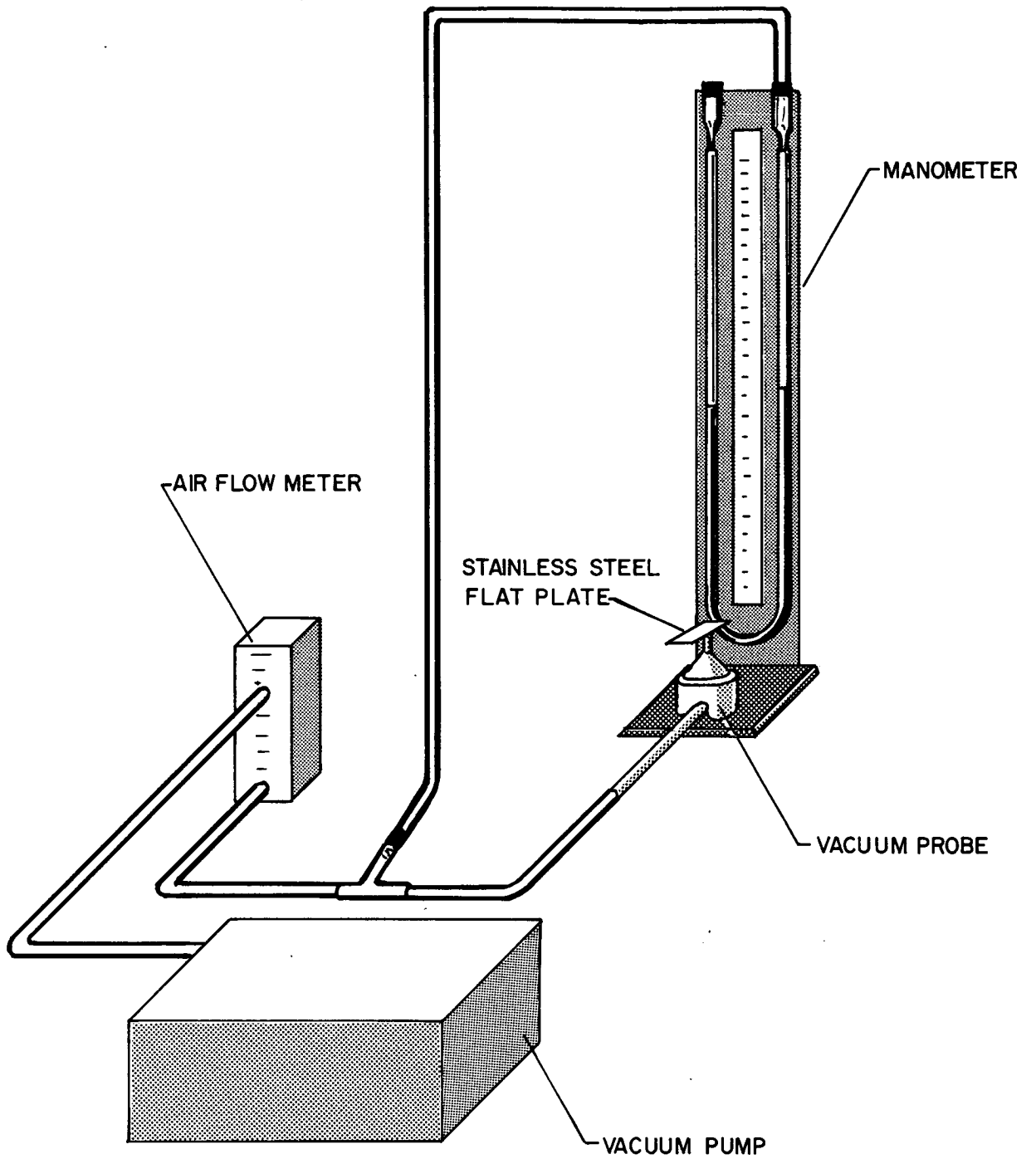
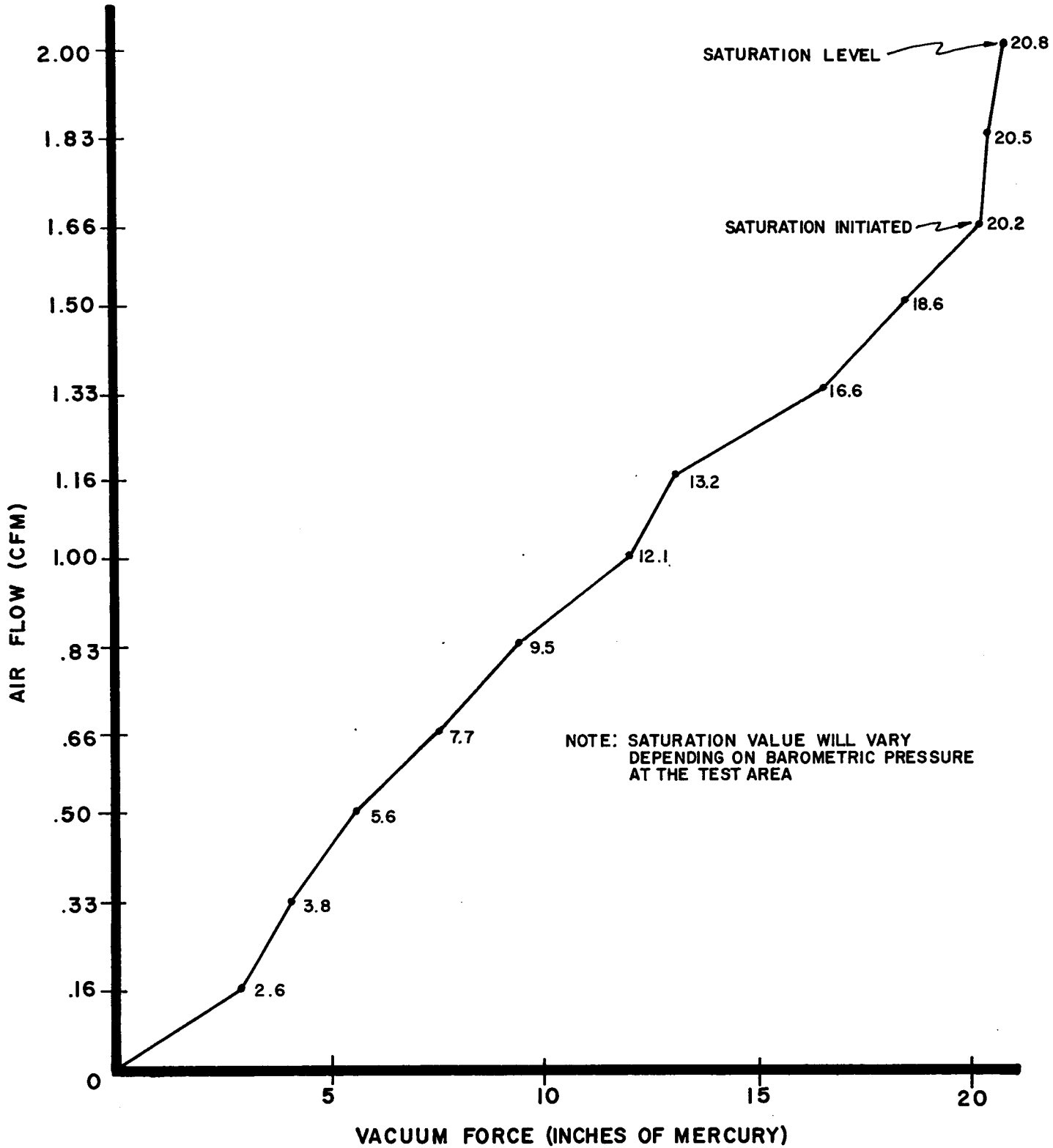

FIGURE 4



- VACUUM SOURCE - GAST VACUUM PUMP - CAPACITY 5.75 CFM
- BAROMETRIC PRESSURE - AVERAGES 30 INCHES OF MERCURY AT TEST AREA

FIGURE 5

I. Packaging and Disposable Cones

The sterile vacuum probe surface sampler cones are packaged in a polyethylene bag sterilized by the B-D ALDESTERI process. The following label is included inside each packaged cone.

**VACUUM PROBE
SURFACE SAMPLER CONE**
Manufactured by
BECTON, DICKINSON and COMPANY
Under Contract No. NAS1-9398
for
NASA Langley Research Center
DO NOT AUTOCLAVE
Sterilized by ALDESTERI process
Contents: one disposable cone and "O" ring assembly

III. OPERATING USE AND INSTRUCTIONS

The vacuum probe surface sampler unit is supplied with three components: the head and handle, the sterilized packaged cone and "O" ring. The head and handle assembly are not sterilized in that these components do not come in contact with the airstream before it is filtered. The cone assembly is packaged in a polyethylene bag which is internally sterilized.

The operator will prepare his sampling facility by providing a vacuum source capable of pulling 28" of vacuum. A standard vacuum hose of appropriate length will form the connection between the probe handle and the vacuum pump. It should be noted that once the vacuum probe is placed under vacuum load that it will not be possible to draw 28" of vacuum due to the design configuration and purpose of the vacuum probe orifice. This orifice is intended to restrict the air flow which therefore must be less than the source. See Figure 5, Saturation Condition.

Once all preliminary arrangements have been made, the operator will perform the following steps to connect the head and cone assembly.

1. Grasp a packaged vacuum probe cone assembly in the hand holding the nozzle between the fingers sufficient to cut open the sterile plastic bag. Caution should be exercised so as not to puncture the plastic bag during this procedure.
2. Obtain a sterile knife and slit the bag open while holding the cone with the open end facing up.
3. Spread the open end of the bag with the sterile knife tip.
4. Select a filter from the sterile package of filters supplied by the investigator and place the filter into the cone assembly.
5. Connect the vacuum pump to the handle.
6. Grasp the probe handle and place it over the cone. The handle should be positioned to facilitate the placement of the handle into the cone at the curved slot in the cone.
7. Once the handle is in position, firmly press the head and cone assembly together being careful to insure a good "O" ring seal connection. A slight mechanical snap will be noticed during this procedure. Once the cone and filter are in place, remove the plastic bag.
8. All handling of the cone should be via the nonsterile side of the bag. The vacuum will tend to pull on the plastic bag. Caution in removing the bag from the nozzle should be exercised.
9. Turn on the vacuum pump.
10. The probe is now ready for use.

IV. CONCLUSIONS

The research performed on the subject contract has resulted in the design and development of new concepts in the automated production of plastic vacuum probe surface samplers.

The design concept of a "tapered-lock" cone and head assembly is produced by very carefully designed and controlled cam action molds. Based on the mold approach to fabrication, unlimited quantities of vacuum probe surface samplers may now be produced economically. Because of this economy, the technique of vacuum probe surface sampling may now become available in a variety of microbiological applications.

The use of plastic moldable vacuum probe samplers has also enhanced the sterile disposability of the sampling cone and eliminated continued resterilization procedures and problems. All cone assemblies were sterilized by a new B-D technique employing the ALDESTERI process. This approach facilitates ease of sterilization packaging. The plastic bag employed is sterilized internally but not externally. The sterile handling of the cone assembly is maintained by the internal surface of the plastic packaging bag. Sterilization could also be accomplished by the conventional technique of ethylene oxide.

The overall objective of the subject contract was attained. A new approach to vacuum probe surface sampler fabrication has advanced the state-of-the-art as a result of this contract.

APPENDIX

A. Invention Disclosure

In the process of conducting development on the subject contract, the design approach conceived by Becton, Dickinson Research Center was unique enough to submit a patent disclosure in accordance with Clause 34, New Technology (May, 1966) of the Contract.

Exhibit "A" briefly describes the nature and extent of the disclosure. A disclosure titled "Vacuum Probe Surface Sampler" was submitted to NASA and assigned NASA Case No. LAR-10623-1. Confirmation of the patent disclosure is represented in Exhibit "B".

B. Publications

A progress report on the Plastic Molded Vacuum Probe Surface Sampler was made at the 1969 Annual Conference of The American Institute of Biological Sciences, Spacecraft Sterilization Technology Seminar. An abstract of this presentation is included in Exhibit "C".

C. Design and Fabrication Process

Alliance Carolina Tool and Mold Company proceeded to prepare working drawings for the mold development from BDRC designs on December 19, 1969. Preliminary shop drawings for the mold designs were delivered on January 9, 1970. A third site visit was made by BDRC personnel regarding mold design changes and corrections which were incorporated in the Alliance design drawings. The final design was approved by BDRC on January 13, 1970, and Alliance was authorized to proceed with the mold design and fabrication. Following this approval, periodic site visits and weekly telephone contact was maintained with Alliance.

Title: Vacuum Probe Surface Sampler

Brief Description (include sketch and formula if necessary):

The Vacuum Probe Surface Sampler is a surface sampling device with the capability for sampling relatively large areas which possess light loading densities of microorganisms. The main concept of this disclosure relates to a tapered mechanical press fit which serves as the attachment mechanism to retain the head assembly and the cone as an integral part during assembling techniques. An additional feature of this concept facilitates the handling of the probe, free of human hands, from a sterile package; and, by virtue of the tripod release mechanism at 120° angles, a solid mechanical shell provides a fast unique, non-contaminated way of releasing the cone assembly.

Advantages:

1. Probe cone is completely sterile and disposable.
2. Easy to assemble or disassemble while maintaining sterility of probe cone.
3. Guaranteed seal with probe head and cone.
4. Positive tip alignment.
5. Lightweight for easy handling.
6. Moldable and inexpensive.

Attach and identify, if available, drawing, sketches, description, data, articles and publication or copies thereof bearing on invention.

Attached

Note all entries made in Laboratory Notebooks, memoranda, correspondence or similar documentation by author, recipient, date, project #, book #, and page # if applicable.

Signature of:

Inventor Bruce A. Zahlava Bruce A. Zahlava Date 9-23-69

Witnessed and Understood by:

(1) Mathew L. Petrovick Mathew L. Petrovick Date 9-23-69

(2) Robert S. Runkle Robert S. Runkle Date 9-23-69



Exhibit "B"

NATIONAL AERONAUTICS AND SPACE ADMINISTRATION

LANGLEY RESEARCH CENTER

LANGLEY STATION

HAMPTON, VIRGINIA 23365

(Mail Stop 173)

November 20, 1969

IN REPLY REFER TO:

Becton, Dickinson and Company
Stanley Street
Rutherford, New Jersey 07070

Attn: Contract Administrator

Gentlemen:

Subject : Invention disclosure entitled VACUUM PROBE SURFACE
SAMPLER
submitted under Contract No. NAS1-9398 ; NASA
Case No. LAR-10623-1

Receipt of the subject invention disclosure by this office is hereby acknowledged. Your cooperation in promptly reporting this invention pursuant to the provisions of the New Technology clause of the referenced contract is greatly appreciated.

This disclosure has been docketed under the above NASA case number for patent prosecution purposes and will be taken up in its proper order for consideration. If in the interim a printed publication of the invention is made which has not previously been reported, it is requested that this fact be brought promptly to the attention of this office.

You are also advised that this invention may be disclosed and published at any time through the NASA Technology Utilization program or through other NASA information dissemination programs. If for any reason you feel that publication and dissemination of the invention disclosure should be withheld, you should promptly notify this office.

Sincerely yours,



Howard J. Osborn
Patent Counsel

Exhibit "C"

American Institute of Biological Sciences
Spacecraft Sterilization Technology Seminar
September 1969

ORGANIZATION: Becton, Dickinson Research Center
Becton, Dickinson and Company

PRINCIPAL INVESTIGATOR(S): G. Briggs Phillips, Ph.D.; Mathew L. Petrovick

NASA CONTRACT NUMBER: NASA 1-9398

TITLE OF OVERALL CONTRACT: Testing and Fabrication of Plastic Vacuum Probe
Surface Samplers

OBJECTIVES: This program provides for the design and development of plastic vacuum probe surface samplers for use in the Planetary Quarantine program that duplicate the performance characteristics of the units originally developed by Sandia Corporation. The program includes consideration of disposable versus re-sterilizable components.

SUMMARY OF LAST THREE MONTHS SIGNIFICANT EFFORTS: Several competitive concepts for development of the plastic surface samplers have been evaluated. The present concept under further evaluation and development concerns provisions of a permanent plastic handle and base with a pre-sterilized, disposable cone and nozzle assembly. This prepackaged unit would also include a sterilized filter. Several distinct advantages can be realized if this development continues to prove feasible. Provision of the cone and filter unit in a pre-sterilized form should minimize, if not eliminate, unwanted variables due to surface contamination of the inner-surface of the cone. In addition, the concept of "one-use" for the cone and nozzle unit will eliminate variables caused by excessive nozzle wear. Additional obvious advantages include lower cost, and lighter weight to facilitate actual use.

DIRECTION AND SCOPE OF FUTURE WORK: A final phase of this six-month contract includes biological varification of the efficiency of the plastic disposable unit in comparison to original data developed by the Sandia Corporation. Successful completion of this program will permit much greater utilization of this unique improved surface sampling concept throughout the Planetary Quarantine program and possibly in other allied fields such as the Health Care area.

As the design and fabrication phase proceeded, it became apparent that Alliance had encountered fabrication problems. Liaison and phone calls corrected the early problems. However, further problems developed as the mold fabrication continued. Alliance repeatedly assured BDRC that all problems were corrected. On a site visit prior to processing the head and cones, Alliance would not allow BDRC personnel to view the molds. It was determined at this time that serious problems in the mold fabrication had been encountered and kept from BDRC. During very close follow-up on each phase of the program, it was determined that Alliance could not produce and process the head and cone assembly such that a tapered-lock fit would result.

A quality control inspection procedure was established by BDRC on incoming samples from Alliance. All samples were rejected due to poor workmanship, poor mechanical tolerances and in general poor control of mold techniques. Alliance delivered samples from four or five attempts in molding, all of which were rejected. As a result, BDRC found it necessary to remove the molds from Alliance in order to complete the work contracted.

Upon receipt of the molds, it was determined that the mold design and fabrication produced were completely incompatible with the design objectives conceived by BDRC, nor did the molds meet the previously approved shop drawings. Based on the molds received, it was evident that the cone and head assemblies could never be produced into the desired device. For all practical purposes, the Alliance molds were almost scrapped.

Based on the above mold status, emergency measures were taken by BDRC to attempt to salvage the molds. The original mold design required by BDRC incorporated the use of removal inserts in event of possible mold sizing problems. The anticipation of the sizing problem was a fortunate one in

that by removing the inserts in the cone and head assembly, it was possible to redesign and correct the mold errors. However, the tolerance errors in the molds were so diverse that considerable effort was required in correcting, fitting, sizing and processing the molded head and cone assemblies.

In addition to the mold and fabrication problems, Alliance failed to produce the teflon tips for the sampling nozzle of the cone. Since the teflon nozzle tips provided the critical orifice required for optimum microbiological sampling efficiency, tolerances could not be opened up. All the teflon tips received from Alliance were rejected due to poor workmanship. It became necessary to rework and remake all of the teflon tips delivered. Most of the quantities ordered were never completed, but only partially fabricated.

In essence, it was necessary for BDRC to completely rework all the molds, teflon tips, handles and accessories received from Alliance. Other than the sizing corrections made in the molds to correct for mold fabrication errors, the original BDRC design as originally conceived and designed during the early conceptual design phase remain the same.

D. Mold Design Drawings

The basic configuration of each mold section is illustrated in the artist's sketches on Figures 10 and 11.

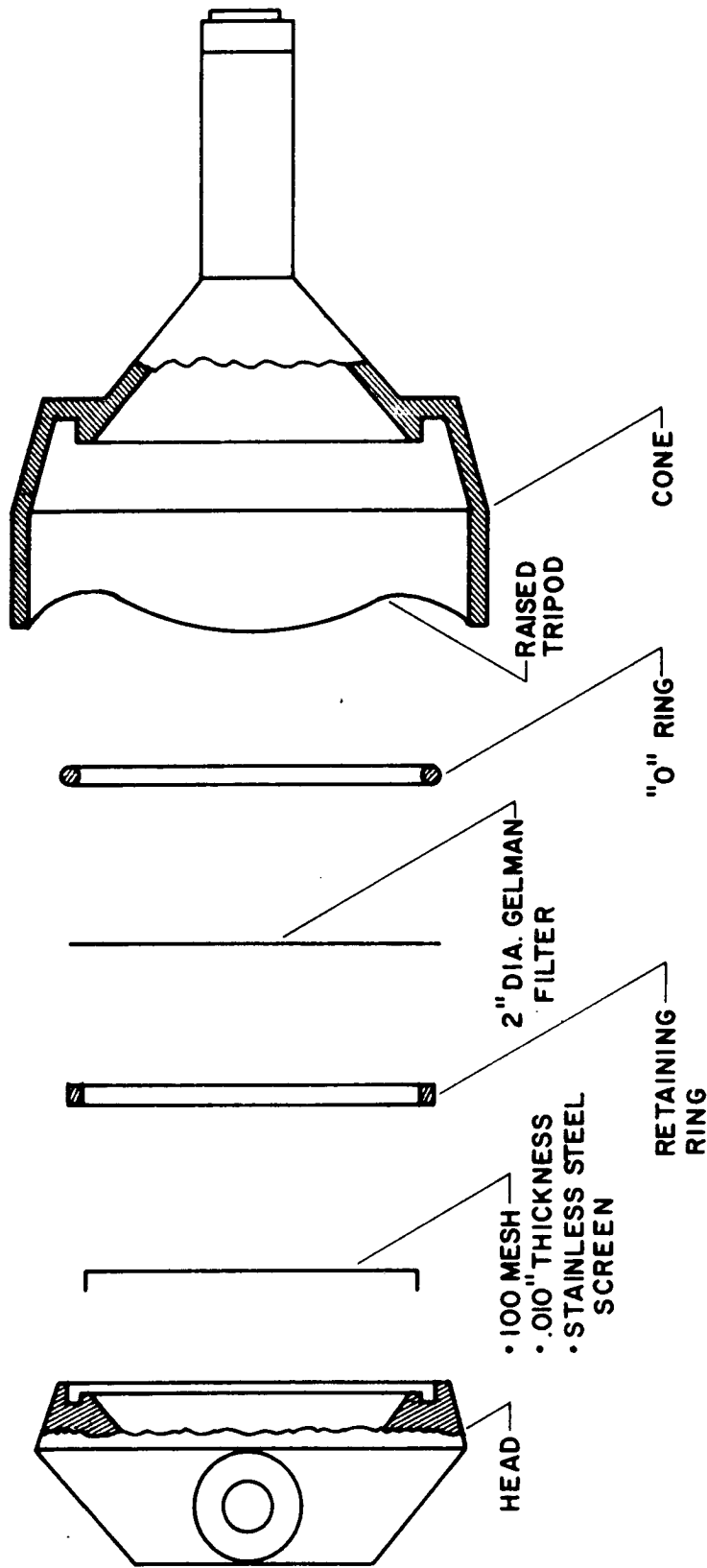

MAJOR ASSEMBLY
 HEAD and CONE

Figure 6

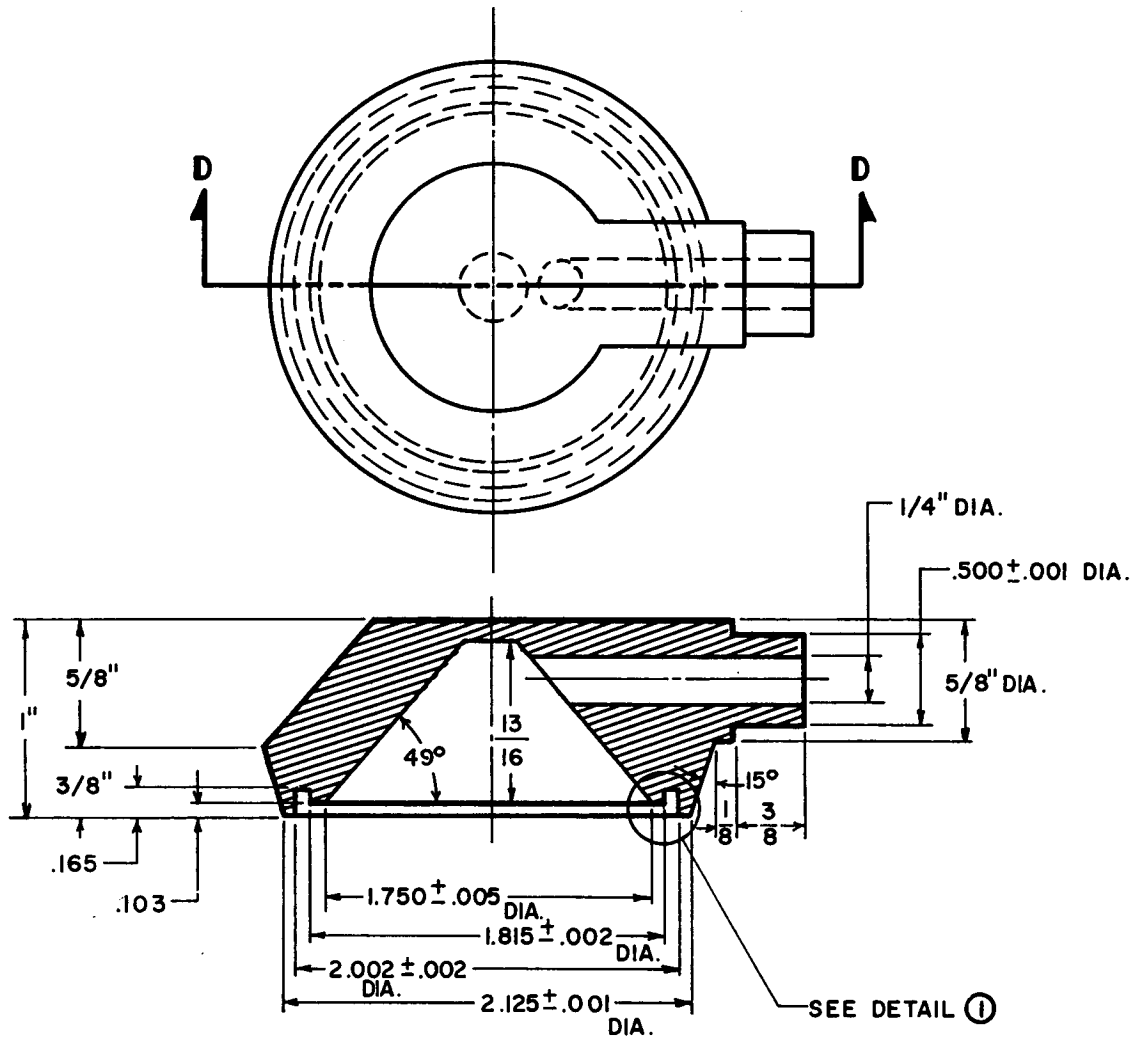

SECTION D-D

NOTE: (DIMENSIONS MUST CORRELATE)
 RETAINING RING MUST MAINTAIN
 INTERFERENCE FIT WHEN ASSEMBLING
 STAINLESS STEEL SCREEN. THIS IS A
 PRESS FIT BETWEEN HEAD, CONE,
 AND RETAINING RING.

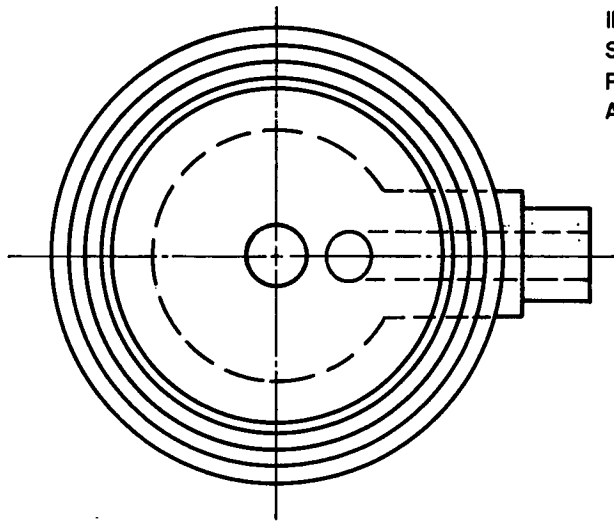

PART ①

PROBE HEAD

MATERIAL: GENERAL PURPOSE WHITE POLYSTYRENE Scale: Full

Figure 7

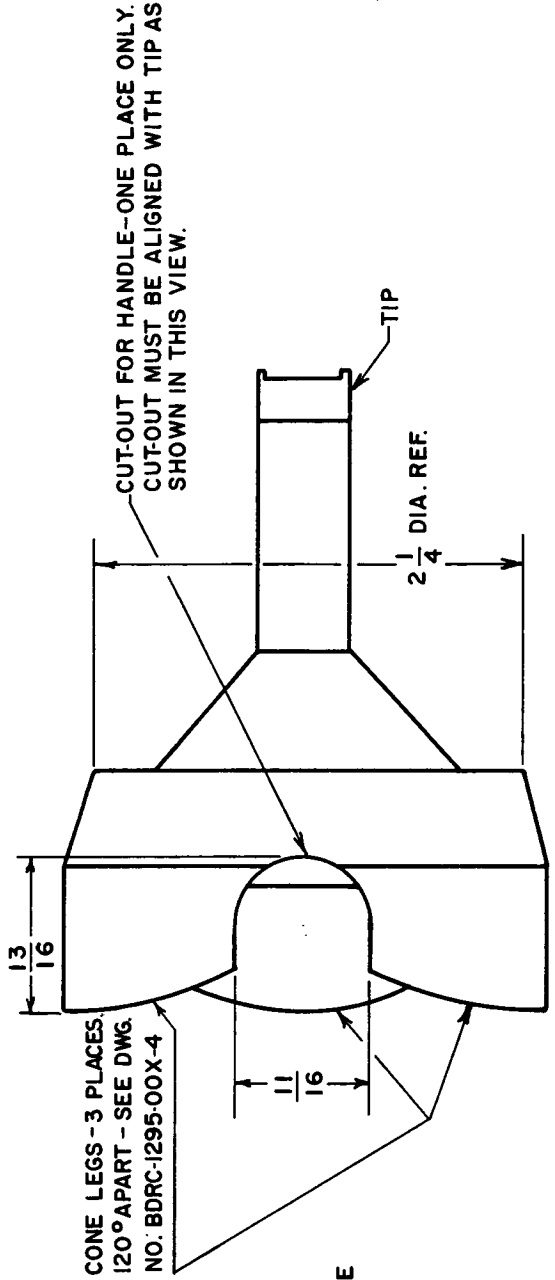
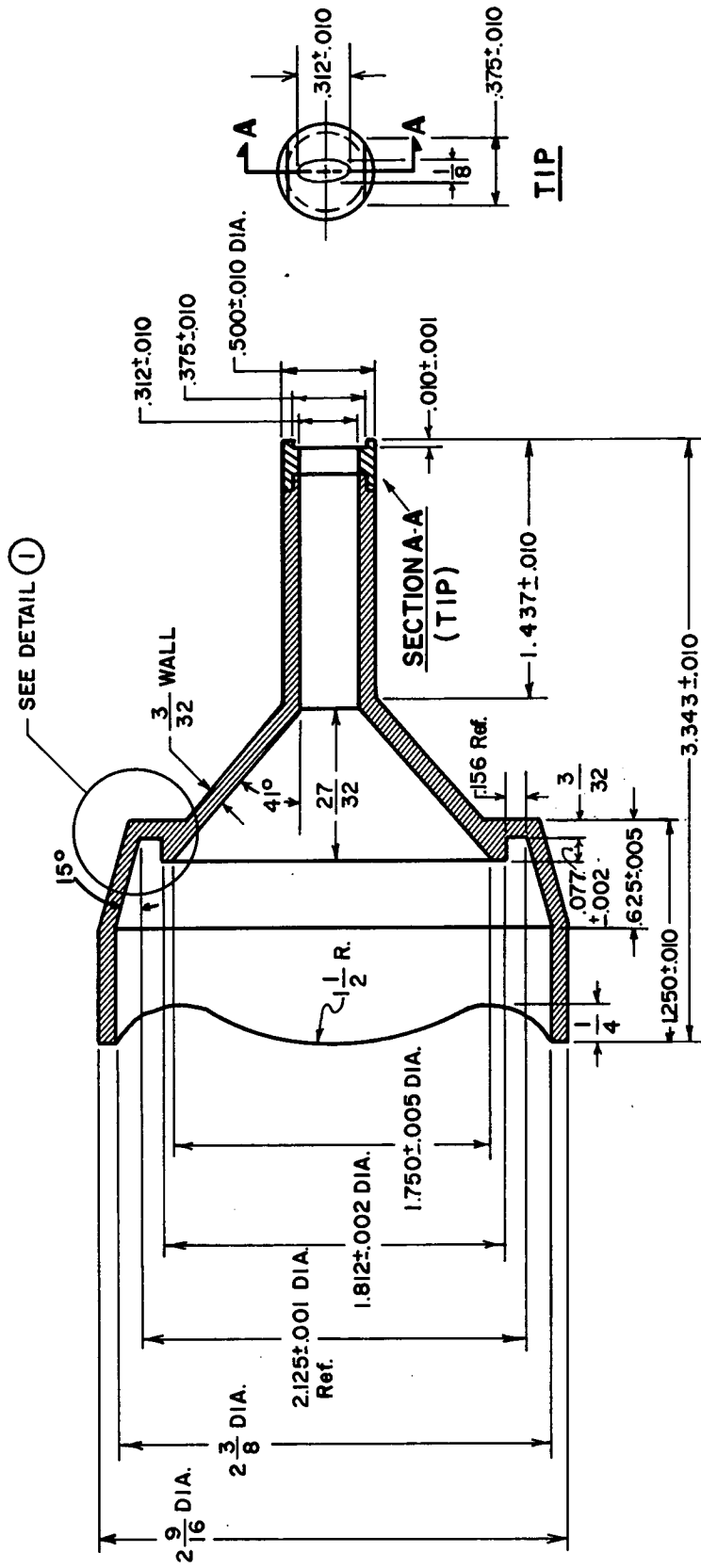

PART ②

PROBE CONE

MATERIAL: GENERAL PURPOSE WHITE POLYSTYRENE
Scale: Full

Figure 8

NOTES

1. MATING OF HEAD AND CONE SECTION IS CRITICAL AND MUST MAINTAIN PRESSURE SEAL PER GIVEN DIMENSIONS. SEE DETAIL ①
2. FLASH NOT TO EXCEED .002"
3. NO FLAKING
4. INSIDE AND OUTSIDE SURFACES MUST BE OF QUALITY FINISH AND APPEARANCE.
5. FILTER THICKNESS AND SCREEN THICKNESS HAVE BEEN TAKEN INTO CONSIDERATION IN ARRIVING AT THE DIMENSIONS.
6. REFERENCE DIMENSIONS MUST COINCIDE WITH PROPER FIT PER DETAIL ①

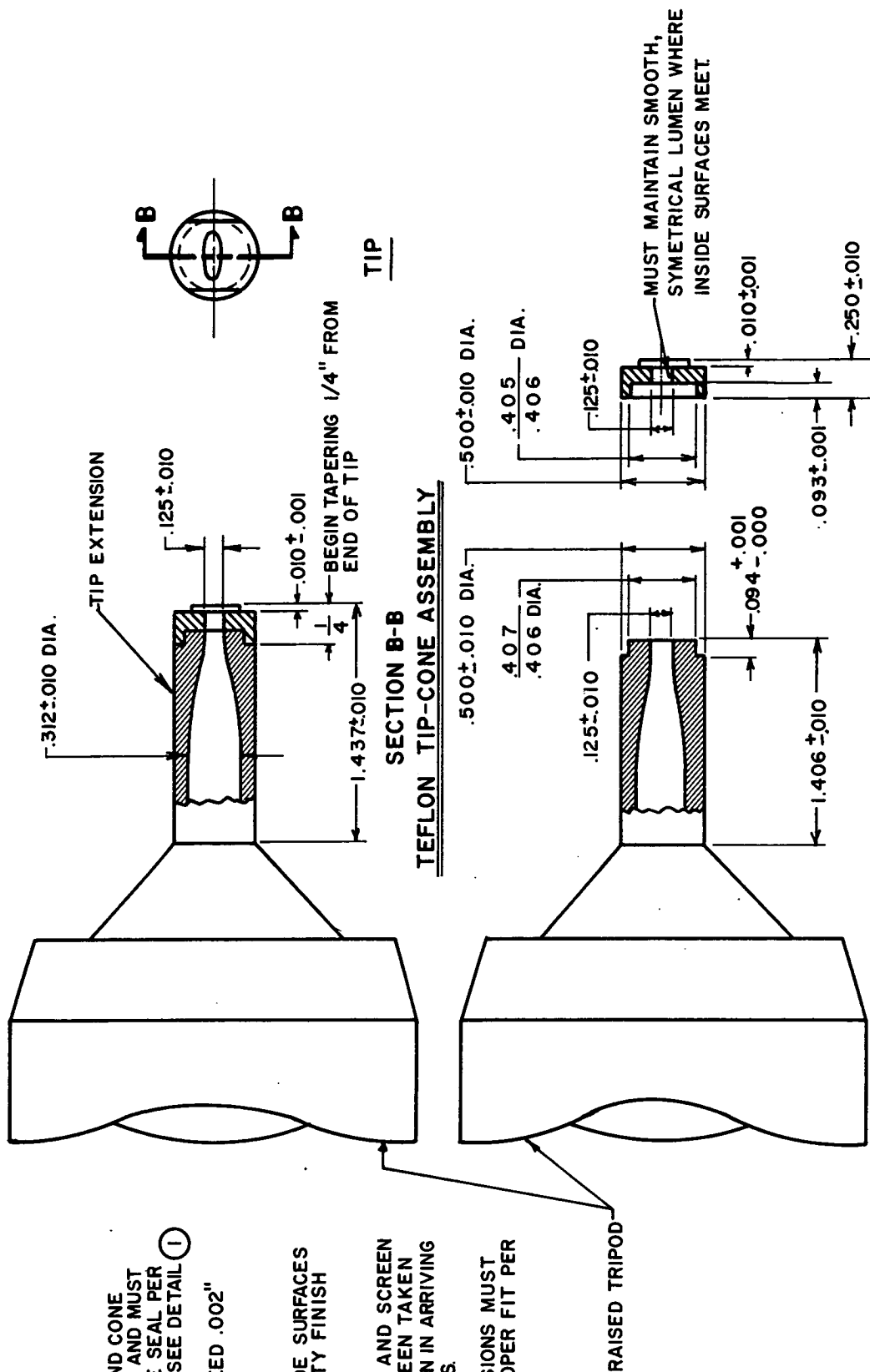

PART ②

PROBE CONE

MATERIAL: GENERAL PURPOSE WHITE POLYSTYRENE

Scale: Full

TEFLON TIP DETAIL

Figure 9

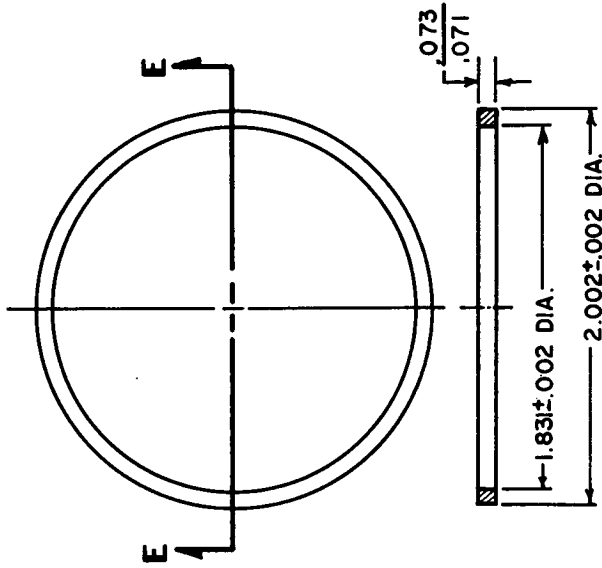
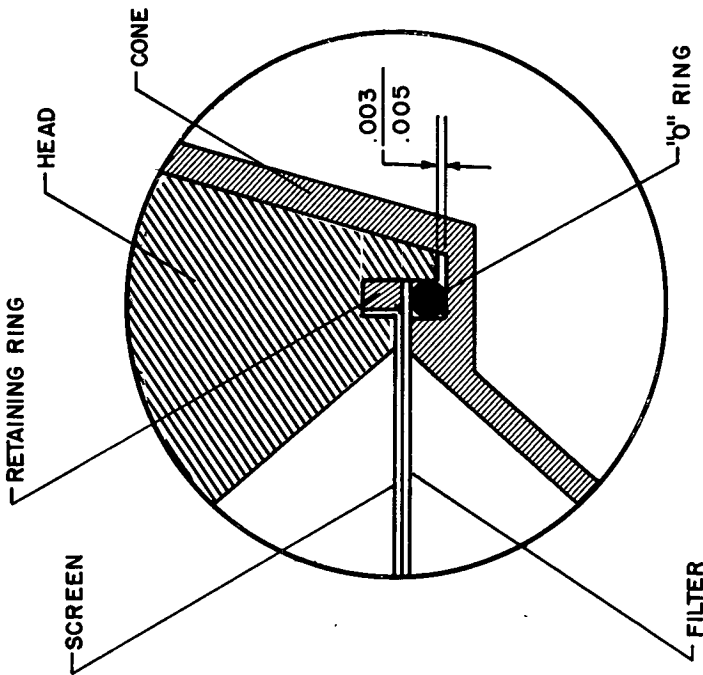

DETAIL ①

NO SCALE

PART ③

RETAINING RING

MATERIAL: GENERAL PURPOSE WHITE POLYSTYRENE
Scale: Full

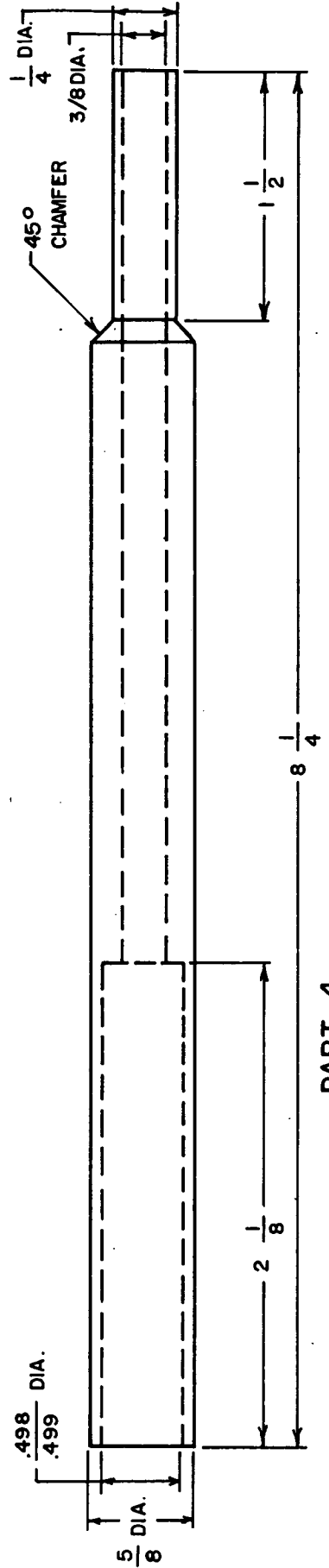

PART 4

HANDLE

MATERIAL: GENERAL PURPOSE WHITE POLYSTYRENE Scale: Full

Figure 9a

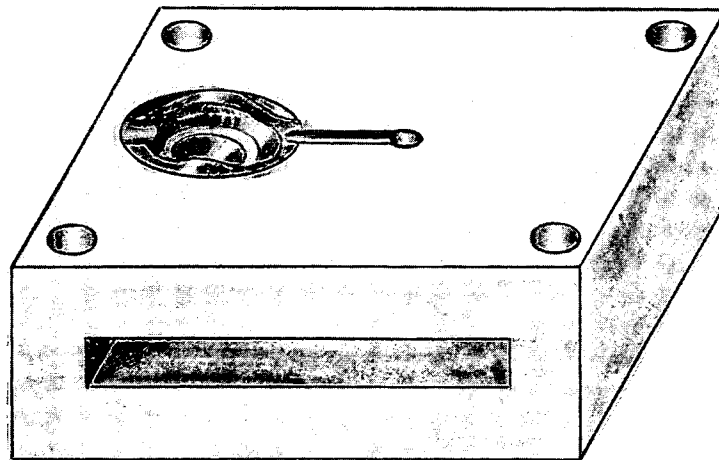
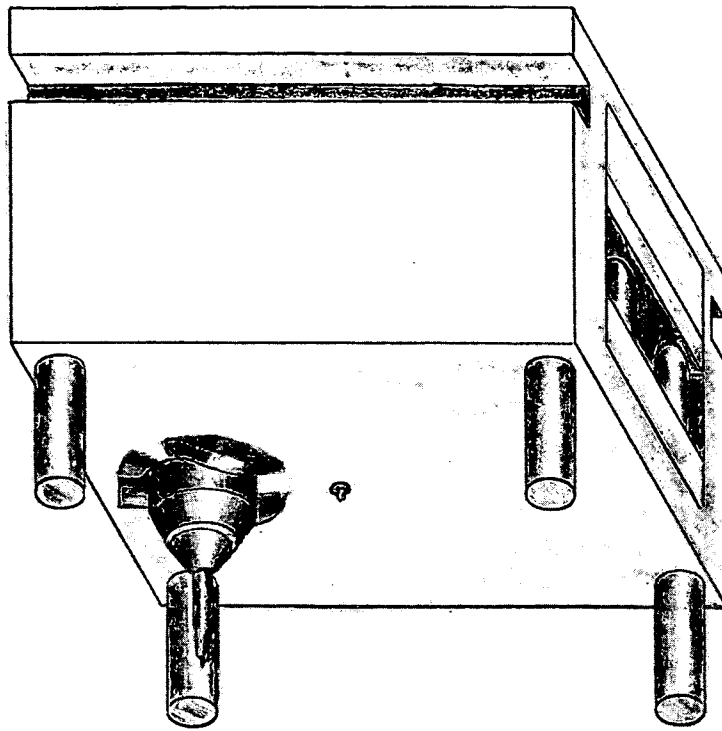

Figure 10
VACUUM PROBE SURFACE SAMPLER MOLD
(CONE ASSEMBLY)

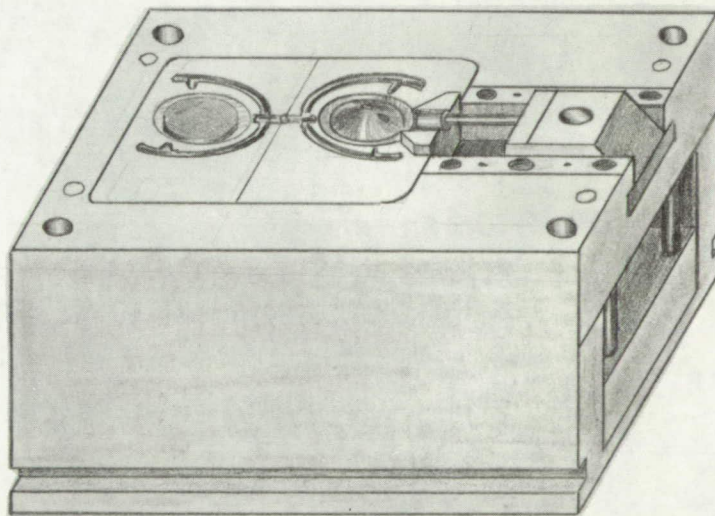
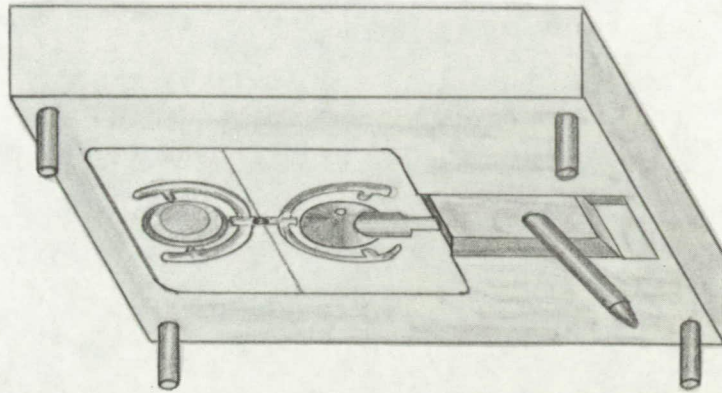

Figure 11
VACUUM PROBE SURFACE SAMPLER MOLD
(HEAD AND RETAINING RING ASSEMBLY)

APPENDIX

A.	Invention Disclosure -----	22
B.	Publications -----	22
C.	Design and Fabrication Process -----	22
	Exhibit "A" -----	23
	Exhibit "B" -----	24
	Exhibit "C" -----	25
D.	Mold Design Drawings -----	27
	Figure 6 -----	28
	Figure 7 -----	29
	Figure 8 -----	30
	Figure 9 -----	31
	Figure 9a -----	32
	Figure 10 -----	33
	Figure 11 -----	34