

N71-17499
NASA CR-116507

TM-71-2014-2

TECHNICAL MEMORANDUM

SIMPLE MASS DISTRIBUTION
FOR THE LUNAR POTENTIAL

CASE FILE
COPY

Bellcomm

BELLCOMM, INC.

955 L'ENFANT PLAZA NORTH, S.W., WASHINGTON, D.C. 20024

COVER SHEET FOR TECHNICAL MEMORANDUM

TITLE- Simple Mass Distribution
for the Lunar Potential

TM-71-2014-2

FILING CASE NO(S)- 310

DATE- February 1, 1971

FILING SUBJECT(S)
(ASSIGNED BY AUTHOR(S))- Mass Distribution
Lunar Potential

AUTHOR(S)- S. L. Levie, Jr.

ABSTRACT

A set of twenty-one point masses gravitationally equivalent to the L1 lunar potential model is presented. By construction, the equivalence is valid only in a region of space "sampled" by Apollo spacecraft. That region is taken to be a finite, torus-shaped shell. When used in place of the L1 model for Apollo 12 lunar orbit determination, the solution set gives spacecraft positions identical to within about 300 feet.

The solution is developed in two steps: first the L1 potential is examined to determine favorable mass locations, and then the mass values are computed to force an optimum matching of the L1 potential. Therefore the solution set is "artificial." It is related to the moon's actual mass distribution only in its similar gravitational effects in a limited region of space.

DISTRIBUTIONCOMPLETE MEMORANDUM TO

CORRESPONDENCE FILES:

OFFICIAL FILE COPY

plus one white copy for each
additional case referenced

TECHNICAL LIBRARY (4)

NASA Headquarters

A. S. Lyman/MR
L. R. Scherer/MAL
W. E. Stoney/MAE

Goddard Space Flight Center

J. Barsky/554
J. P. Murphy/552

Langley Research Center

W. H. Michael, Jr./152A
R. H. Tolson/152A

Manned Spacecraft Center

J. P. Mayer/FM
J. C. McPherson/FM4
E. R. Schiesser/FM4
W. R. Wollenhaupt/FM4

Aerospace Corporation

L. Wong

Bell Telephone Laboratories

W. M. Boyce/MH
B. G. Niedfeldt/WH

Jet Propulsion Laboratory

P. Gottlieb/233-307
J. Lorell/156-217
W. L. Sjogren/180-304

National Oceanic and
Atmospheric Administration

F. Morrison

COMPLETE MEMORANDUM TOComputer Sciences Corporation

D. H. Novak

Bellcomm, Inc.

G. R. Andersen
R. A. Bass
A. P. Boysen, Jr.
J. O. Cappellari, Jr.
K. R. Carpenter
K. M. Carlson
C. L. Davis
F. El-Baz
W. W. Ennis
D. R. Hagner
W. G. Heffron
H. A. Helm
N. W. Hinners
T. B. Hoekstra
A. N. Kontaratos
M. Liwshitz
K. E. Martersteck
W. I. McLaughlin
J. Z. Menard
G. T. Orrok
P. S. Schaenman
R. V. Sperry
J. W. Timko
R. L. Wagner
D. B. Wood
M. T. Yates
All Members Department 2014
Department 1024 File

Abstract Only to

NASA Headquarters

R. A. Petrone/MA

Bellcomm, Inc.

J. P. Downs
D. P. Ling
M. P. Wilson

SUBJECT: Simple Mass Distribution
for the Lunar Potential
Case

DATE: February 1, 1971

FROM: S. L. Levie, Jr.

TM-70-2014-2

TECHNICAL MEMORANDUM

1. INTRODUCTION

A distribution of twenty-one point masses gravitationally equivalent to the L1 lunar potential model over a restricted region of space is determined in this paper. Since the results must be understood in a rather detailed context, they are deferred to Section 4. Although for practical work the distribution seems to be neither more nor less useful than the L1 model, it does offer a usable, alternative representation of the L1 model. More generally, the method employed may be used to construct a mass representation for any potential.

The object being matched, the L1 lunar potential model, is an approximation to the moon's gravitational potential. It has been used extensively in real-time orbit determination for recent Apollo flights. Consider a series expansion of the moon's potential V in terms of solid spherical harmonics. This may be written as

$$V(r, \theta, \phi) = (GM/r) \sum_{\ell=0}^{\infty} \sum_{m=0}^{\ell} (R/r)^{\ell} P_{\ell}^m(\cos\theta) \times [C_{\ell m} \cos m\phi + S_{\ell m} \sin m\phi], \quad (1)$$

in which GM is the gravitational constant times the moon's mass and R the mean lunar radius; (r, θ, ϕ) are the spherical polar coordinates of a field point outside the moon, at which the potential is to be evaluated; $P_{\ell}^m(\cos\theta)$ is the unnormalized

*The values assumed for these quantities are
 $GM = 1.7313997 \times 10^{14} \text{ ft}^3/\text{sec}^2$ and $R = 5,702,395 \text{ ft}$.

associated Legendre function defined in [1] or [2]; and $C_{\ell m}$ and $S_{\ell m}$ are the expansion coefficients of V . The L_1 potential is a finite approximation to the infinite series (1). It is characterized by the six non-zero coefficients listed in Table 1. These coefficients were determined by a community of American selenodiscists after careful processing of doppler tracking data from Lunar Orbiter satellites and from Apollos 8 and 10 [3]. In the region of lunar space sampled by these spacecraft, the L_1 model gives a representation of the underlying lunar potential which has been satisfactory for lunar navigation and orbit determination in the Apollo program.

TABLE 1

Non-Zero Expansion Coefficients
Characterizing the L_1 Lunar Potential Model

C_{00}	1.0
C_{20}	$-.207108 \times 10^{-3}$
C_{22}	$.20716 \times 10^{-4}$
C_{30}	$.21 \times 10^{-4}$
C_{31}	$.34 \times 10^{-4}$
C_{33}	$.2583 \times 10^{-5}$

Recognizing that the moon's gravitational potential exists by virtue of a mass distribution, one would like to draw conclusions about the mass distribution from the present knowledge of the potential. Unfortunately, because the potential is an integral over the mass distribution, it is impossible to infer a unique distribution from knowledge of the potential alone. A classic example of this phenomenon is given by a point mass and a uniform spherical shell of equal mass, both of which have the same external potential. However, when additional information (such as extensive seismic data) about the moon's interior becomes available, it may be possible to use it to discriminate between various distributions determined by considering only the potential.

For the present, since there is no means for such discrimination, we will be content to determine a simple mass distribution which is gravitationally equivalent to the L1 potential model. "Equivalent" is construed as requiring the L1 potential and the simple distribution to produce nearly the same state vectors at all times during lunar orbit determination for a spacecraft orbiting within a region in which the L1 potential is valid. The region is taken to be a torus-shaped shell lying within the space blocked out by the orbits studied for the construction of the L1 potential. It simulates the lunar space explored by Apollo spacecraft. "Simple" is construed as requiring a smallest distribution of point masses which will produce equivalence.

The method employed involves selecting the locations of point masses within a distribution and then using a least squares integral criterion to determine the optimum mass values for the distribution. The mass values are optimum in the sense that they force a minimum of the integrated square of the difference between the L1 potential and the potential due to the selected distribution. The integration region is the torus-shaped shell just described. The mass locations may be iterated to diminish the value of the criterion integral until it is satisfactorily close to zero. Satisfactoriness is checked by applying the gravitational equivalence criterion mentioned above.

This method is believed to have been suggested originally by McLaughlin [4]. A least squares matrix reformulation [1] of McLaughlin's integral criterion was adopted for this work because of its superior flexibility.

It may be noted that this program is qualitatively related to recent efforts at JPL [5,6,7] and Aerospace [8], in which hundreds of masses on the nearside lunar surface are fitted directly to spacecraft doppler data on a single-pass basis. Whereas those efforts are designed to include local gravitational information, use of the L1 potential restricts this work to information averaged over the whole moon. Both approaches share the problem of inherent non-uniqueness of solution mass distributions, but this does not obscure physical interpretations in the referenced work, due to the presence of supplementary, topographic information.

This work is also related to studies reported in [9] and [10], in which surface mass distributions are obtained for the earth from satellite tracking data and from gravity anomaly information.

Section 2 deals with the method of determining the mass values for an assumed distribution, while Section 3 discusses the selection of the mass locations within a distribution. The distribution of twenty-one point masses which solves the posed problem is the subject of Section 4. Some conclusions about the work are given in Section 5.

2. CALCULATION OF THE MASSES

Once a distribution of masses has been selected, its net gravitational potential \tilde{v} can be computed, provided the mass of each body has been specified. Since it is desired to have \tilde{v} match a given potential v over some region D of space, McLaughlin [4] proposed selecting the mass values so that the integral

$$f = \int_D (v - \tilde{v})^2 d\tau \quad (2)$$

is minimized. Thus the resulting solution will be optimum in an integral least squares sense. Since potentials are linear in the mass, \tilde{v} can be written as

$$\tilde{v} = \sum_{k=1}^n m_k \tilde{v}_k, \quad (3)$$

where n is the total number of bodies, m_k the mass of the k^{th} body, and $m_k \tilde{v}_k$ the potential of the k^{th} body. Thus f is quadratic in the masses, and its minimum is unique.

In the application being presented, v was taken as the L1 potential model. It was represented as a sum of solid spherical harmonics in the form of (1), but truncated after $\ell=7$. The potentials of each of the masses under consideration in (3) were expanded in similar series, truncated after $\ell=7$. The coefficients for these series may be computed from formulas in [11]. From (3), then, \tilde{v} is also a truncated sum of solid spherical harmonics, and each coefficient in the sum is a certain linear combination of n undetermined masses.

With the problem in this form, the integral criterion (2) can be reformulated as a classical least squares matrix

problem, reported in [1]. This formulation was used for the computations, since it allows convenient utilization of a computer, by isolating the integral in f in a weight matrix. Every element of the weight matrix is an integral over D of products of pairs of solid spherical harmonics, and these integrals can be analytically precomputed.

The region within which the L_1 potential and the mass distribution were matched -- the integration region D in (2) -- was chosen to be a finite, torus-shaped shell. Its inner and outer surfaces are spherical, with radii R and $R + 2 \times 10^6$ ft,* and the northern and southern surfaces are cones of latitude at 30° and -30° . The weight matrix for such a region is given in [1]. The region was arbitrarily chosen as modeling the space sampled by Apollo spacecraft, and it is contained within the region in which the L_1 potential model is presumed to be a good representation of the underlying lunar potential.

3. SELECTION OF THE MASS LOCATIONS

The availability of the integral criterion for selecting mass values for the bodies in a distribution substantially simplifies the problem under consideration. The remaining problems are to select the necessary number of bodies and then to determine locations for them. For simplicity, it will be assumed that all the bodies are point masses. This does not seem to weaken the solution, even for a small number of masses.

There appear to be three ways of selecting point masses for the distribution. Each requires a single mass at the origin to account for the gross, radially symmetric part of the moon's density function. The methods are:

1. Place a point at the location of each suspected inhomogeneity.
2. Distribute points evenly over some spherical surface, to approximate a surface distribution of matter.
3. Place "multipole" patterns of points very close to the origin.

* R is defined in Section 1, and is 5,702,395 ft.

The first approach is out of the question due to insufficient information. The second and third are related, in the scheme which was used, and both are deeply rooted in potential theory. The second is based on a theorem that on the surface of a sphere there exists a distribution of matter which reproduces a given external potential [12]. The third states a result in electrostatics, that any external potential may be replaced by a suitable collection of multipoles [13]. A multipole is an infinitesimal arrangement of point masses whose total external potential consists of just one term of (1) and (except for the central body term) whose total mass is zero. Each term of (1) has its corresponding multipole.

The multipole approach has been the most useful one for obtaining mass point locations. Since the symmetries of a single multipole distribution are connected with the locus of zeros of the corresponding spherical harmonic, only the pattern of zeros needs to be consulted to get an indication of the relative positions of mass points in the corresponding multipole. These patterns are shown in Figure 1 for the spherical harmonics needed in the L1 potential model, omitting the central body term. The distribution of twenty points in Figure 2 seems to capture all the symmetries shown in Figure 1. It also seems to be the smallest such set. Mass points at the indicated locations plus a mass point at the origin constitute the distribution of twenty-one point masses whose values were determined by minimizing (2).

The radius of the sphere on which the points were placed is 0.2109R. For the distribution to approximate a true set of multipoles, the sphere's radius should approximate zero. This cannot be done in practice, of course, since the resulting distribution would appear to a computer to be singular. The adopted value was therefore a compromise between the requirements of a good multipole representation and numerical tractability.

Although the distribution has just been presented in the context of multipoles, it has another interpretation. It is also a simple approximation to a continuous distribution of matter on a spherical surface. The approximation consists of a uniform surface distribution, represented by the point mass at the origin, which is modulated by a sprinkling of twenty discrete masses on the surface. This interpretation emphasizes that the moon's actual mass distribution is not being determined here. What is being determined is some distribution which reproduces the effects of the L1 potential model within a torus-shaped shell.

4. RESULTS

The mass distribution determined by the methods of the last two sections is presented in Table 2. It consists of twenty point masses placed symmetrically on a sphere of radius $0.2109R$, plus a point mass at the center. This mass point contains nearly all the mass in the distribution, to within one percent. The total mass of the distribution equals the moon's mass; the center of mass is within ten feet of the origin; and the cross products of inertia are zero. These results stem from matching a spatial distribution and a potential with related symmetries, while using a highly symmetric region for the fit.

Table 3 lists the expansion coefficients $C_{\ell m}$ (refer to (1)) for this distribution up to $\ell = m = 7$. The S-coefficients are all zero. Comparison with Table 1 shows that the expansion coefficients for the distribution are not the same as those of the L1 potential. The reason is that the distribution is inherently incapable of reproducing the L1 potential at all points of space. That is, it cannot generate the L1 coefficients exclusively.

The solution distribution does give a satisfactory facsimile of the L1 potential within the torus-shaped shell, however. This was demonstrated by using the potential coefficients in Table 3 for two-pass orbit determination with free-fall doppler data from Apollo 12.* Comparison with results from orbit determination using the L1 potential model revealed errors in the epoch state amounting to 328 ft and 0.12 fps. The doppler residuals for the two potentials were nearly indistinguishable over a five revolution propagation of the two epoch state vectors. When the number of mass points in the solution set was decreased, these results were seriously degraded, indicating that the set presented is the simplest practical one.

It is interesting to compare equipotential contours for the L1 model and the solution mass distribution. These are shown in Figures 3 and 4, respectively. Careful comparison of the two figures reveals an excellent match within the fit zone and a deteriorating match outside the fit zone. The fine information in the L1 potential near -180° in the fit zone suffers some distortion in the mass point representation, but, on the basis of the previous paragraph, this does not seem to be particularly harmful. The situation probably would be improved by adding one or two mass points to the solution set.

*The elements of the orbits considered were approximately $a = 6,061,500$ ft, $e = 0.00502$, $i = 164^\circ 86'$, $\Omega = 335^\circ 6'$, $\omega = 66^\circ 6'$, in the selenographic frame. The period was about 1.979 hr.

Table 2 -- A distribution of mass points reproducing the gravitational effects of the L1 lunar potential model throughout a torus-shaped shell.*

Mass Location**		Mass (μM)***
latitude (deg)	longitude (deg)	
45	0	1340
0	0	- 656
-45	0	1798
45	60	- 604
0	60	-1792
-45	60	- 146
45	120	-1210
0	120	1782
-45	120	- 752

Mass Location**		Mass (μM)***
latitude (deg)	longitude (deg)	
45	180	-2039
0	180	1409
-45	180	-1581
45	-120	-1210
0	-120	1782
-45	-120	- 752
45	- 60	- 604
0	- 60	-1792
-45	- 60	- 146
90	0	- 436
-90	0	-2384
(coordinate origin)		1,007,996

*The inner and outer surfaces of the shell are spheres of radii R and $R + 2 \times 10^6$ ft, where $R = 5,702,395$ ft. The northern and southern surfaces are cones of latitude at $+30^\circ$ and -30° .

**All the mass points lie on a sphere of radius $0.21085789R$, except for one at the coordinate origin.

***The mass unit is micromoons, or 10^{-6} lunar masses.

Table 3 -- Low-order expansion coefficients for the potential of the mass distribution in Table 2. The S-coefficients are not given, since they are all zero. Mantissa-exponent format is used.

C_{00}	1.000	C_{53}	.6037 - 9
C_{10}	.9859 - 6	C_{54}	0.0
C_{11}	- .5910 - 6	C_{55}	- .9183 - 9
C_{20}	- .2073 - 3	C_{60}	- .1908 - 6
C_{21}	0.0	C_{61}	0.0
C_{22}	.2087 - 4	C_{62}	.1430 - 8
C_{30}	.2281 - 4	C_{63}	0.0
C_{31}	.3303 - 4	C_{64}	.7990 - 10
C_{32}	0.0	C_{65}	0.0
C_{33}	.2584 - 5	C_{66}	- .2693 - 13
C_{40}	- .2870 - 6	C_{70}	.2963 - 7
C_{41}	0.0	C_{71}	- .4280 - 8
C_{42}	.1667 - 6	C_{72}	0.0
C_{43}	0.0	C_{73}	.2322 - 9
C_{44}	.1359 - 7	C_{74}	0.0
C_{50}	.1242 - 5	C_{75}	.1077 - 10
C_{51}	- .5141 - 6	C_{76}	- .1954 - 12
C_{52}	0.0	C_{77}	- .2835 - 12

5. CONCLUSIONS

On the basis of the orbit determination comparison, it is concluded that the mass distribution in Table 2 and the L1 lunar potential model yield similar gravitational effects in the region of space "sampled" by Apollo spacecraft. That region is assumed to be a torus-shaped shell. Some calculational comparisons of these two representations of the lunar potential have shown that neither is more efficient than the other. This underlines the practical equivalence of the two representations in the stated region.

There appear to be three ways of improving the correspondence of the distribution's potential to the L1 potential:

1. Increase the number of mass points, to make a better approximation of a continuous surface distribution.
2. Move all the mass points closer to the origin, in the spirit of multipole theory, to diminish the size of unwanted expansion coefficients in the distribution's potential.
3. Adjust the region in which the match is to be valid so that the distribution needs to match fewer convolutions of the given field.

The first approach is plausible, but unesthetic, and the second is limited by numerical considerations in the calculations. However, the third approach is simultaneously practical, consistent with the spirit of McLaughlin's criterion, and consistent with the realities of our present understanding of the moon's gravitational potential.

It is expected that if the scheme for determining an equivalent mass distribution is applied to potentials only slightly more intricate than the L1 field, then the number of mass points required will grow steeply. This is because a mass point distribution must capture simultaneously all the symmetries of the spherical harmonics comprising the gravitational potential to be matched. This would mean exorbitant numbers of mass points in the multipole sets for such fields.

It is not meaningful to discuss the physical reality of the solution mass distribution. This is because, as shown in [13], a mass distribution whose external potential precisely matches some given potential lacks uniqueness. However, as more becomes known about the moon's interior, the new information can possibly be used to differentiate between acceptable solutions. For the present, the solution obtained must simply be regarded as an alternative representation of the L1 lunar potential model for Apollo orbits.

ACKNOWLEDGEMENTS

Thanks are due to M. H. Gittes for her efficient programming of the necessary calculations, and to W. I. McLaughlin and W. W. Ennis for several fruitful discussions about mass distributions and their potentials.

Sterling Levie, Jr.
S. L. Levie, Jr.

2014-SLL-vh

Attachments
Figures 1-4

REFERENCES

- [1] Levie, S. L, Jr., "Fitting a Mass Distribution to a Potential," Bellcomm, Inc., Memorandum for File, Washington, D. C. February 1, 1971.
- [2] Emde, F., and Jahnke, E., Tables of Functions with Formulae and Curves, Dover, New York (1945).
- [3] Wollenhaupt, W. R., "Apollo Orbit Determination and Navigation," paper no. 70-27, presented at 8th Aerospace Sciences Meeting, New York, January, 1970.
- [4] McLaughlin, W. I., "Representation of a Gravitational Potential with Fixed Mass Points," Bellcomm, Inc., Memorandum for File B68-12109, Washington, D. C. (December 23, 1968).
- [5] Muller, P. M., and Sjogren, W. L., "Mascons: Lunar Mass Concentrations," Science, vol. 161, p. 680 (August 16, 1968).
- [6] Muller, P. M., and Sjogren, W. L., "Lunar Surface Mass Distribution Map from Dynamic Mass Point Solutions," The Deep Space Network (Space Programs Summary 37-60, Vol. II), Jet Propulsion Laboratory, p. 103 (1970).
- [7] Gottlieb, P., "Estimation of Local Lunar Gravity Features," Radio Science, vol. 5, p. 301 (February, 1970).
- [8] Wong, L., "Lunar Gravitational Model Derived from Doppler Data," presented at Spring AGU meeting, Washington, 1970.
- [9] Koch, K. R., and Morrison, F., "A Simple Layer Model of the Geopotential from a Combination of Satellite and Gravity Data," JGR, vol. 75, no. 8, p. 1483 (March, 1970).
- [10] Obenson, G. F. T., "Direct Evaluation of the Earth's Gravity Field from Orbital Analysis of Artificial Earth Satellites," Department of Geodetic Science Report No. 129, The Ohio State University (March, 1970).
- [11] Levie, Jr., S. L., "Transformation of a Potential Function under Coordinate Translations," Bellcomm, Inc., Technical Memorandum TM 70-2014-7, Washington, D. C. (August 13, 1970) [to be published in Journal of the Astronautical Sciences].

REFERENCES (CONT.)

- [12] MacMillan, W. D., The Theory of the Potential, p. 393, Dover, New York (1958).
- [13] Feshbach, H., and Morse, P. M., Methods of Theoretical Physics, Vol. II, p. 1276, McGraw-Hill, New York (1953).

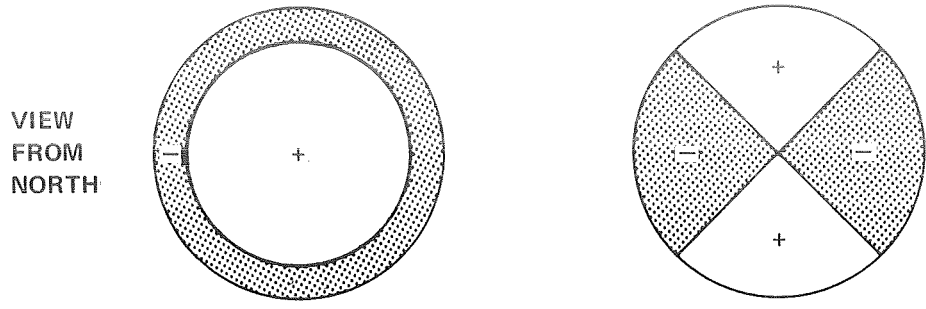

(2,0)

(2,2)

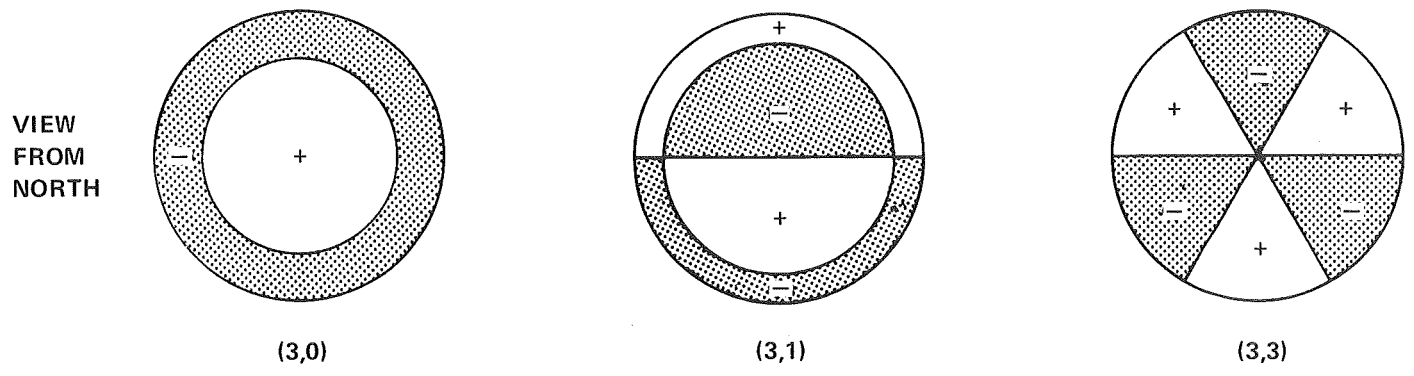
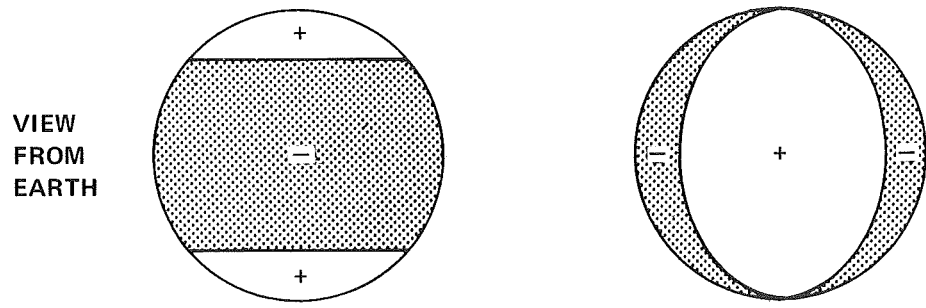

(3,0)

(3,1)

(3,3)

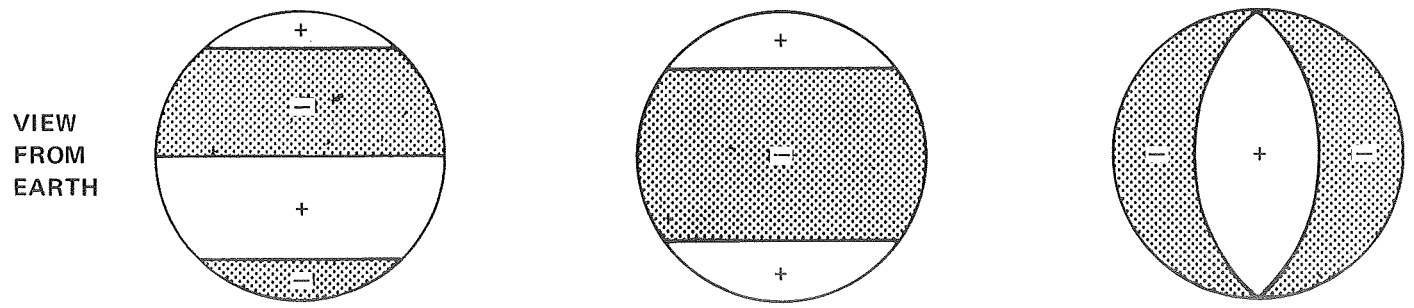
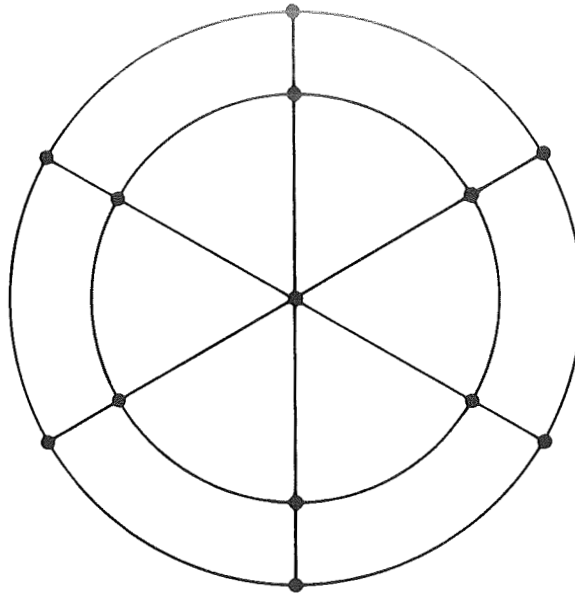

FIGURE 1 - PATTERNS OF ZEROS OF THE SPHERICAL HARMONICS IN THE L1 LUNAR POTENTIAL MODEL (EXCLUDING THE CENTRAL BODY TERM). NOT DRAWN TO SCALE

VIEW
FROM
NORTH



VIEW
FROM
EARTH

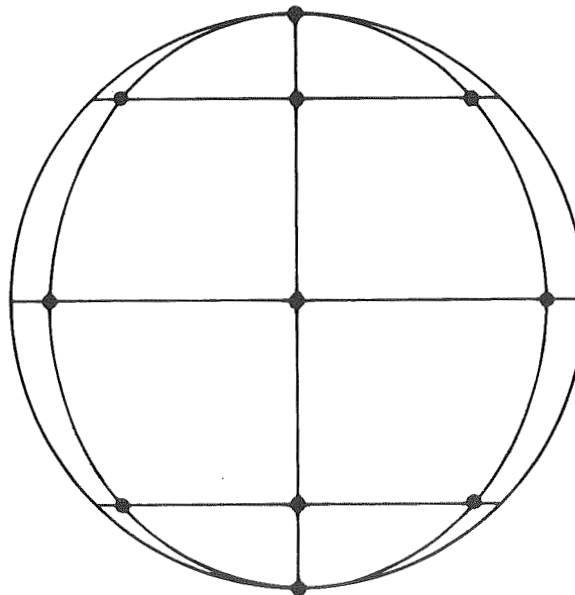

FIGURE 2 - DISTRIBUTION OF TWENTY MASS POINTS WITH THE SYMMETRIES OF THE SPHERICAL HARMONICS OF THE L1 POTENTIAL MODEL (EXCLUDING THE CENTRAL BODY TERM). THE SOUTHERN HEMISPHERE IS REFLECTION - SYMMETRIC WITH THE NORTHERN HEMISPHERE. DRAWN TO SCALE

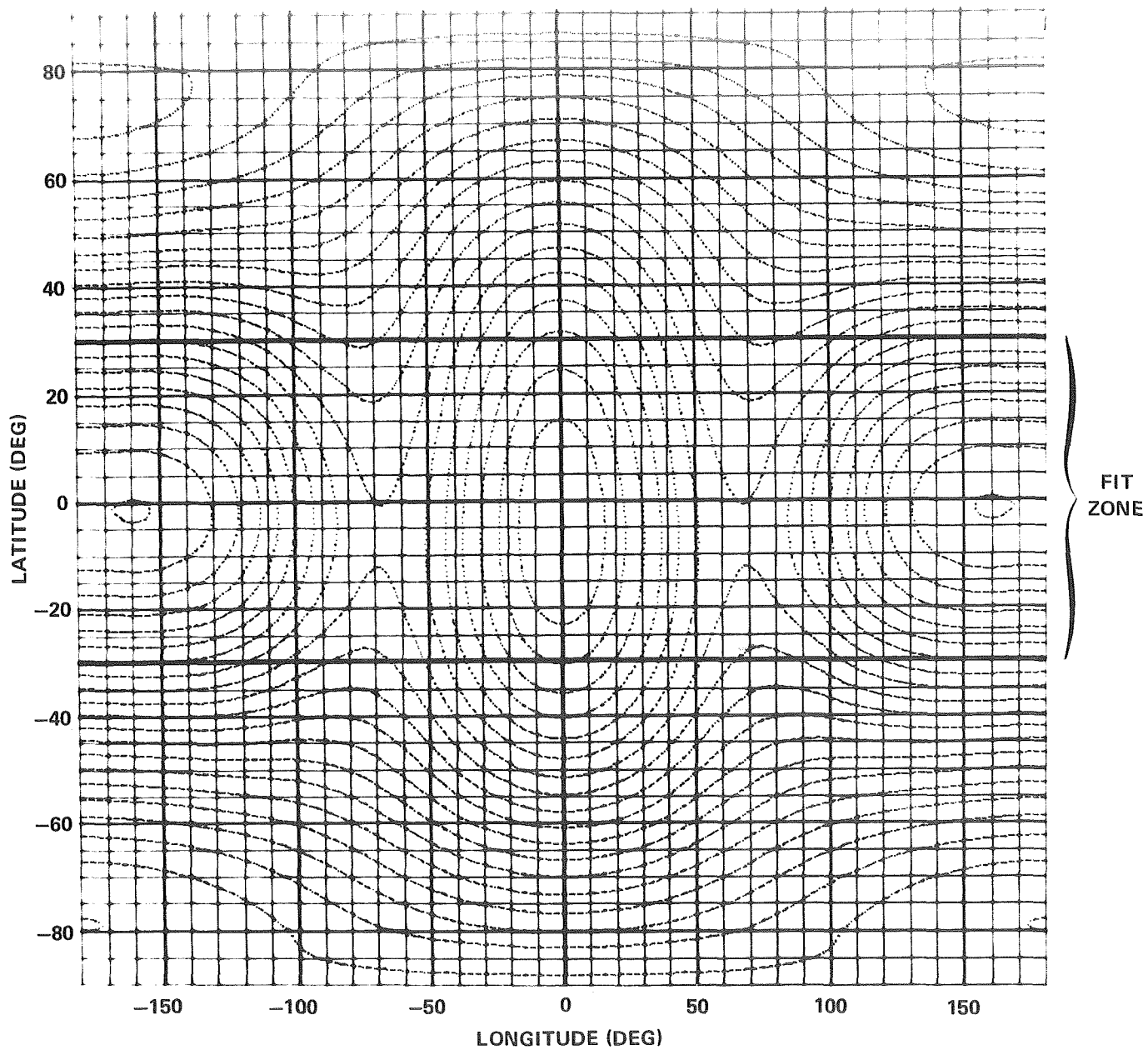

FIGURE 3 - EQUIPOTENTIAL CONTOURS FOR THE L1 POTENTIAL. THE FIT ZONE LIES BETWEEN $+30^{\circ}$ AND -30° LATITUDE, AS SHOWN

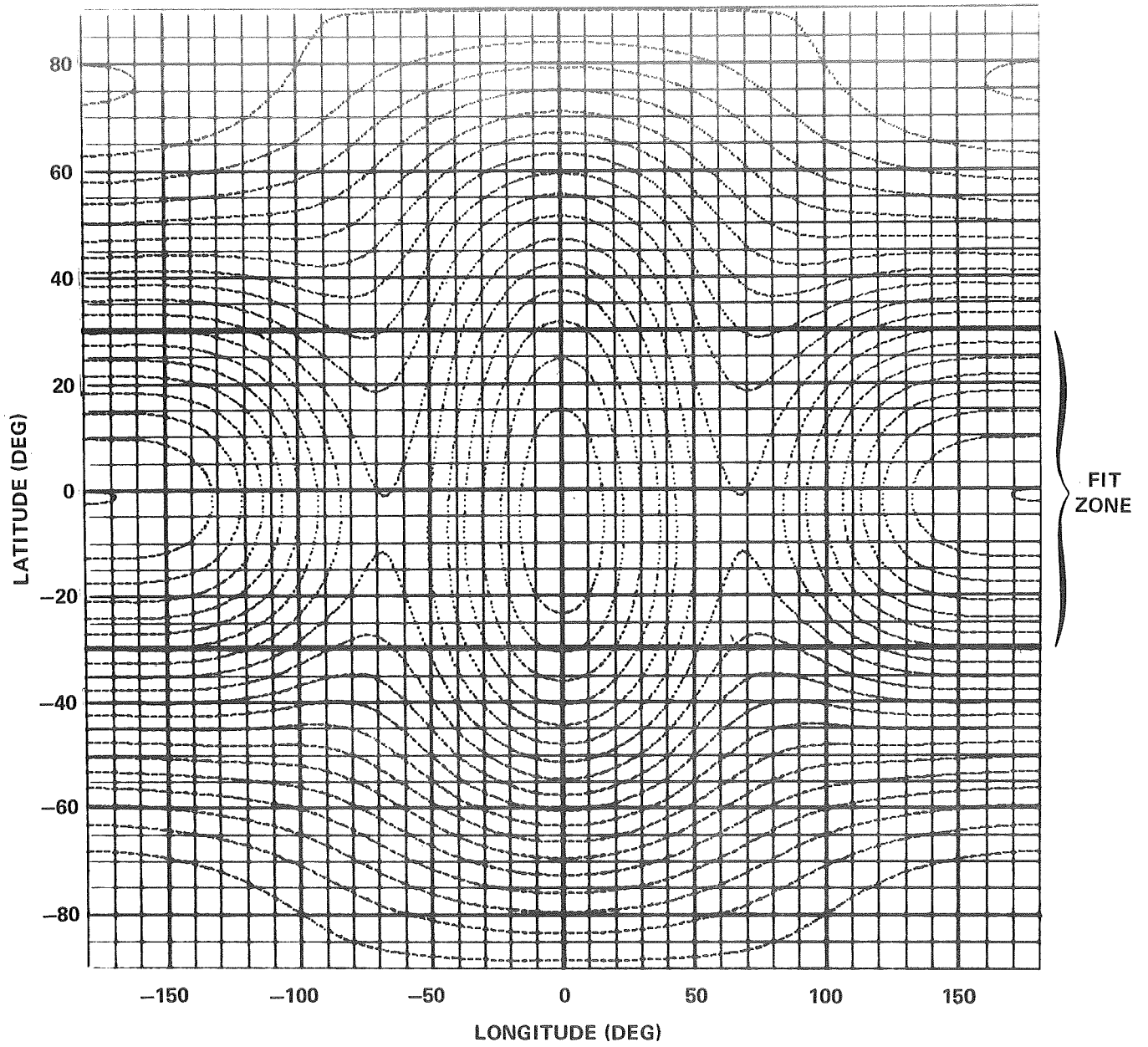

FIGURE 4 - EQUIPOTENTIAL CONTOURS FOR THE 21 MASS POINT POTENTIAL. THE FIT ZONE LIES BETWEEN $+30^{\circ}$ AND -30° LATITUDE, AS SHOWN

