

FINAL TEST REPORT  
FOR  
PULSE OPERATED FLOW PATH SELECTOR VALVE ASSEMBLY

Hydraulic Research P/N 39000750  
NASA/MSFC P/N 20M42517, Rev. C.

Contract No. NAS 8 -30075

Prepared by

Avco Corporation  
Systems Division  
Lowell, Massachusetts 01851

Prepared for

National Aeronautics & Space Administration  
George C. Marshall Space Flight Center  
Huntsville, Alabama 35812

FACILITY FORM 802

77-21997  
ACCESSION NUMBER

NASA CR-103086  
(PAGES)

(CATEGORY)

(CODE)

(FORM)

(MARK OR ON THE OR AS NUMBER)

Author: R. Rouleau  
R. Rouleau

Approved by: T. K. Pugmire  
T. K. Pugmire  
Program Manager

Final Test Report --  
For  
Pulse Operated Flow Path Selector Valve Assembly  
Contract NAS 8-30075

Prepared by: Avco Corporation/Systems Division  
Lowell Industrial Park  
Lowell, Massachusetts 01851

**CASE FILE  
COPY**

1-1241 R7-66

## Table of Contents

<u>Para.</u>	<u>Title</u>	<u>Page</u>
	Abstract .....	(iii)
	Foreword .....	(v)
1.0	Introduction.....	1
2.0	Test Requirements.....	2
3.0	Test Procedures .....	2
4.0	Test Results.....	3
4.1	Pre-Test Inspection.....	3
4.2	Cleaning .....	3
4.3	Acceptance.....	3
4.4	Vibration .....	7
4.5	Functional Tests After Vibration.....	8
4.6	Transient Pulses .....	11
4.7	Life Cycling.....	13
4.7	Functional Tests After Life Cycling.....	19
4.8, 4.9	High and Low Temperature, Gaseous.....	20
4.10	Functional Tests After High/Low Temperature, Gaseous .....	25
4.11, 4.12	High and Low Temperature, Liquid.....	27
4.13	Functional Tests After High/Low Temperature, Liquid .....	31
4.14	Full Flow .....	34
4.15	Humidity .....	35
4.15	Functional Tests After Humidity.....	35
4.16	Collapse Pressure.....	37
4.17	Burst Pressure.....	38
4.18	Thermal Cycling .....	38
4.18	Functional Tests After Cycling.....	38

Addenda

<u>Addendum</u>	<u>Title</u>	<u>Pages</u>
A	Test Procedure .....	A-1 to A-38
B	Procurement Specification .....	B-1 to B-28
C	Test Equipment & Instrumentation .....	C-1 and C-2
D	Data Sheets .....	D-1 to D-166
E	Photographs .....	E-1 to E-7
F	Deviation Request .....	F-1 to F-3

FINAL TEST REPORT  
FOR  
PULSE OPERATED FLOW PATH SELECTOR VALVE ASSEMBLY

Hydraulic Research P/N 39000750  
NASA/MSFC P/N 20M42517, Rev. C.

ABSTRACT

Two (2) Pulse Operated Flow Path Selector Valve Assemblies were subjected to a comprehensive series of tests to qualify their use on the ATM Thermal Control System. The valves were manufactured by Hydraulic Research and Mfg. Co.

The test program demonstrated that the test items satisfy all of the requirements of specification 20M42517 with exception of the Coil Transient Voltage (para. 4.3.4.15) requirement as written. However, when installed in an actual system, and operated with the NASA designed control circuits, the performance of the valve does satisfy the specified Coil Transient Voltage requirement. Noteworthy also is that the test items demonstrated significant performance margins beyond the minimum requirements of the procurement specification.

The two test items were subjected to the series of tests outlined below, with numerous functional tests before, during, or after environments.

- |    |                     |     |                     |
|----|---------------------|-----|---------------------|
| 1. | Pre-Test Inspection | 7.  | Temperature         |
| 2. | Cleaning            | 8.  | Full Flow           |
| 3. | Acceptance Tests    | 9.  | Temperature Cycling |
| 4. | Vibration           | 10. | Humidity            |
| 5. | Transient Pulses    | 11. | Collapse            |
| 6. | Life Cycling        | 12. | Burst               |

## Foreword

The formal preflight certification test program for the ATM Temperature Control System Flow Path Selector valve was conducted by the Space Subsystems Department, Avco Systems Division, Lowell, Massachusetts, 01851. The tests were witnessed by Avco SD Quality Control Personnel and by Air Force Quality Assurance Representatives. The testing period was from 20 May 1970 through 4 December 1970. The test was conducted in accordance with STP-SSD-1024 in compliance with the requirements of NASA/MSFC procurement specification 20M42517, Rev. C. This test program was authorized by Contract NAS8-30075.

## 1.0 Introduction

### 1.1 Scope

This report presents the results of the Preflight Certification Tests conducted on two Flow Diverter Valve Assemblies. The objective of the test was to qualify the valve design for use in the Apollo Telescope Mount Thermal Control System, by demonstrating conformance to NASA procurement specification 20M42517, Rev. C. The two specimens tested are defined as follows:

<u>Test Sample</u>	<u>Vendor</u>	<u>P/N</u>	<u>S/N</u>
1	Hydraulic Res. & Mfg.	39000750	007
2	" " " "	" " " "	008

### 1.2 Item Description

The Flow Diverter Valve is a two position latching valve. Flow is diverted from either of two inlet ports to a common outlet port. The valve is pulse actuated, and magnetically latched. Two microswitches are provided to indicate armature position. Overall size of the valve is approximately 4.6 x 5.2 x 4.1 inches. A complete description and functional schematic of the valve are included in Addendum A, pages 4, 5, 6, and 7. Photographs of the valve are located in Addendum E.

### 1.3 Applicable Documents

Applicable specifications, standards and drawings are listed on pages 1 and 2 of Addendum A.

### 2.0 Test Requirements

NASA/MSFC procurement specification, 20M42517, Rev. C (Addendum B) establishes the test requirements. Environmental Tolerances, Measurement Tolerances, Ambient Conditions, Failure Definition, Deviations, Data Recording and Test Facilities are listed in Addendum A, pages 2 through 4.

#### 2.1 Test Summary

The test samples were subjected to the tests listed below

<u>Test</u>	<u>Specification Para.</u>	<u>Sample Number</u>	
		1	2
Pre-Test Inspection	4.3.2	x	x
Cleaning	3.5	x	x
Acceptance Tests	4.3.5	x	x
Vibration	4.3.4.9	x	x
Transient Pulses	4.3.4.12	x	x
Life Cycling	4.3.4.10	x	x
Temperature	4.3.4.6	x	x
Full Flow	4.3.4.5	x	x
Temperature Cycling	4.3.4.7	x	
Humidity	4.3.4.1		x
Collapse	4.3.4.13		x
Burst	4.3.4.14		x

Note: Numbers refer to paragraphs in specification 20M42517.

### 3.0 Test Procedure

The detailed procedures for the Pre-Flight Certification Tests are outlined in Test Procedure STP-SSD-1024 which is included in Addendum A to this report. This document includes both procedures and



test schematics. Only those tests described herein and summarized in paragraph 2.1 were conducted.

#### 4.0 Test Results

The actual test results described in this section are recorded in Addendum D, entitled Test Data.

##### 4.1 Pre-Test Inspection

The results of the pre test inspection are recorded on addendum pages D-1 and D-2. Deviation Requests were made and approved for both valves via DAR #005 and 007, which are included as Addendum F. These involved loose threads on the flange mounting pads, and did not affect the performance of the test items. The Deviation Requests were approved by NASA/MSFC for test use only.

##### 4.2 Cleaning

Both test items were cleaned to the requirements of Contamination Control Plan, QATP-SD-199. Both test items were cleaned to a level of 50 microns or less.

##### 4.3 Acceptance Tests

###### 4.3.1 Proof Pressure

A 75 psig proof pressure test with GN<sub>2</sub> was successfully conducted on both test items for more than the specified 5 minute period, without evidence of distortion, permanent set or leakage. The results are recorded on Addendum pages D-1 and D-2.

#### 4.3.2 External Leakage

Both test items total leakage measurements were better than the specified  $1.6 \times 10^{-6}$  requirement, when pressurized with 100% helium at 50 psig. The results of these tests are recorded on pages D-1 and D-2.

#### 4.3.3 Internal Leakage

The poppet leakage measurements for both test items over a pressure range of 0 to 20 psig, were less than two orders of magnitude below the allowable 0.20 sccs of the methanol/water service media. The leakage results for three cycles of operation are listed on addendum pages D-3 and D-4.

#### 4.3.4 Acceptance Vibration

Both test items were subjected to a 2.7 g rms, overall, random vibration level without evidence of damage or external leakage. The valves were charged with GN<sub>2</sub> at 20 psig. Results of this test, including the random analysis plot, are recorded on Addendum pages D-3 and D-4.

#### 4.3.5 Vacuum Internal

Both test items were subjected to  $2 \times 10^{-5}$  torr without evidence of deformation or permanent set. Results of these tests are recorded in pages D-5 and D-6.

#### 4.3.6 Proof Pressure

A 75 psig proof pressure test with GN<sub>2</sub> was applied to the test specimens after Acceptance Vibration. There was no visual evidence of deformation or permanent set, or leakage. The data are recorded in the Addendum pages D-5 and D-6.

#### 4.3.7 Leakage External, After Acceptance Vibration

Post vibration leakage was successfully completed on both test items. Leakage values were better than the allowable  $1.6 \times 10^{-6}$  sccs. The test data are recorded on Addendum pages D-5 and D-6.

#### 4.3.8 Internal Leakage After Acceptance Vibration

Poppet leakage measurements for both test items were less than two orders of magnitude below the allowable 0.20 sccs of methanol/water service media with pressures from 0 to 20 psig. The data are recorded on Addendum pages D-7 and D-8.

#### 4.3.9 Circuit Resistance

Continuous circuits on both test items measured less than the 0.5 OHM allowable value. Coil resistance conformed to contractor drawing requirements of  $27 \pm 2$  OHMS, and open circuits indicated infinitely high resistance. Test results are listed on Addendum pages D-7, D-8, D-9 and D-10.

#### 4.3.10 Insulation Resistance

All insulation resistance measurements on each test item exceeded 20,000 megohms. The test requirement is 50 megohms minimum. These data are recorded on Addendum pages D-9, through D-16.

#### 4.3.11 Minimum Operating Voltage (Unpressurized Assembly)

The minimum operating voltage for valve S/N 007 in the unpressurized condition ranges from 12.0 to 14.5 volts. For S/N 008, the voltage was between 12.8 and 17.0. The specified requirement is 18.0 volts maximum. These voltages were applied for 100 milliseconds. The results of each run are listed on Addendum pages D-15 and D-16.

#### 4.3.12 Minimum Operating Voltage (Pressurized Assembly)

The minimum operating voltage for the valve pressurized to 50 psig with helium ranged from 10.0 to 12.8 volts for S/N 007, and from 12.4 to 16.0 for S/N 008. The requirements are the same as the unpressurized condition. The results of the tests are recorded on Addendum pages D-15 and D-16.

#### 4.3.13 Minimum Pulse Duration (Pressurized Assembly)

The minimum pulse duration for valve S/N 007 in the pressurized condition (50 psig) ranged from 15.3 to 21.0 milliseconds. For S/N 008, the pulse duration was between 15.0 and 17.5 milliseconds. The specified requirement is 100 milliseconds maximum. These pulses were applied with a 28.0 volt amplitude. The data collected are recorded on Addendum page D-17 and D-18.

#### 4.3.14 Minimum Pulse Duration (Unpressurized Assembly)

The minimum pulse duration for the test items in the unpressurized condition ranged from 16.5 to 22.0 milliseconds, for S/N 007, and from 16.5 to 18.0 for S/N 008. The requirements are the same as for the pressurized condition. Test results are recorded on Addendum pages D-17 and D-18.

#### 4.3.15 Power Consumption

The room temperature power consumption at 28.0 volts d. c. was 27.44 watts maximum for valve S/N007, and 29.96 watts maximum for valve S/N 008. The allowable power consumption is 45 watts maximum. These measurements are recorded on Addendum pages D-17 and D-18.

#### 4.4 Vibration

##### 4.4.1 Vibration, Sinusoidal Excitation, Vehicle Dynamics

Both test samples were subjected to sinusoidal vibration excitation from 4 to 40 cps with 1.6 g peak along the longitudinal axis, and from 4 to 20 cps at 0.4 g's peak along the lateral axes. Continuity was maintained across pins A and E during the test and the valves were pressurized to 21.0 psig. There was no visual evidence of damage or leakage on either valve at the completion of the test. Accelerometers were mounted on the test items to sense acceleration along the three major axes. The output of each accelerometer was recorded on an oscillographic strip chart and is available at Avco in the test data file. The overall results of this test are recorded on Addendum pages D-19, and D-20.

##### 4.4.2 Vibration, Sine Evaluation Criteria

A 1 g amplitude sine survey was conducted from 20 to 2000 cps along the major axes of both test units. Continuity was maintained across pins A & E during the test, and there was no evidence of external leakage or damage. The valves were pressurized to 21 psig with methanol/water. Accelerometers were mounted on the test items, as described in 4.4.1. These results are recorded on Addendum pages D-19 and D-20.

#### 4.4.3 Vibration, Random Criteria, High Level

Both test items were subjected to a 5.3 grms (overall) random vibration test along each of the three major axes. Both valves were pressurized to 21.0 psig with the service media. Continuity was maintained across pins A and E during the test, and there was no evidence of external leakage, or damage. The test results are recorded on Addendum pages D-19 and D-20.

#### 4.4.3 Vibration, Random Criteria, Low Level

Both test items were subjected to a 3.6 g rms (overall) random vibration test along each of the three major axes. Both valves were pressurized to 21.0 psig with the service media. Continuity was maintained across pins A and E during the test, and there was no evidence of external leakage, or damage. The test results are recorded on Addendum pages D-21 and D-22.

### 4.5 Post Vibration Functional Tests

#### 4.5.1 Proof Pressure

A 75 psig proof pressure test with  $\text{GN}_2$  was conducted on each test item. Neither valve exhibited any evidence of deformation or leakage. The results are recorded on Addendum pages D-21 and D-22.

#### 4.5.2 Vacuum

The test items were subjected to less than  $1 \times 10^{-5}$  torr for more than 5 minutes. Neither valve exhibited any evidence of deformation or set. The data are recorded on Addendum pages D-21 and D-22.

#### 4.5.3 External Leakage

External leakage measurements on both test items were less than the  $1.6 \times 10^{-6}$  sccs by greater than one order of magnitude, when pressurized with 100% helium at 50 psig. These measurements are recorded on Addendum pages D-23 and D-24.

#### 4.5.4 Internal Leakage

Poppet leakage on each valve was less than two orders of magnitude below the allowable 0.2 sccs of the methanol/water service media, at pressures from 0 to 20 psig. The leakage values are recorded on Addendum pages D-23 and D-24.

#### 4.5.5 Circuit Resistance

All resistance measurements on each test item were less than 0.5 OHMS (allowable) for closed circuits and infinity, for open circuit measurements. Coil resistances were within the manufacturer's specified limits. These measurements are recorded on Addendum pages D-25 and D-26.

#### 4.5.6 Insulation Resistance

All insulation measurements on each test item exceeded 20,000 megohms. The specified requirement is for 50 megohms minimum. Insulation resistance data are recorded on Addendum pages D-27 through D-32.

#### 4.5.7 Minimum Operating Voltage, Unpressurized

The minimum operating voltage, applied for 100 ms, ranged from 14.0 to 16.0 volts for valve S/N 007 and from 13.0 to 16.0 for S/N 008. The allowable limit is 18.0 volts. The data are recorded on Addendum pages D-31 and D-32.

#### 4.5.8 Minimum Operating Voltage, Pressurized

The minimum voltage with the valves pressurized with 100% helium to 50 psig ranged from 13.0 to 14.5 for valve S/N 007, and from 13.0 to 14.0 volts for valve S/N 008. The data are recorded on Addendum pages D-33 and D-34.

#### 4.5.9 Minimum Pulse Duration, Pressurized

The minimum pulse duration for the test items pressurized to 50 psig with 100% helium ranged from 34.0 to 39.0 ms for valve S/N 007 and from 34.0 to 36.0 for valve S/N 008. The pulse amplitude was 28.0 volts, and the allowable pulse width is 100 ms, maximum. These results are recorded on Addendum pages D-33 and D-34.

#### 4.5.10 Minimum Pulse Duration, Unpressurized

The minimum pulse duration for the unpressurized condition ranged from 30.0 to 39.0 ms for valve S/N 007 and from 36.0 to 38.0 ms for valve S/N 008. Other conditions and limits as in para. 4.5.9. These results are listed on Addendum pages D-33 and D-34.



#### 4.5.11 Power Consumption

The room temperature power consumption at 28.0 volts d. c. was 27.3 watts maximum for valve S/N 007, and 29.96 maximum for valve S/N 008. The allowable value is 45 watts. These measurements are recorded on Addendum pages D-35 and D-36.

#### 4.6 Transient Pulses

##### 4.6.1 Minimum Operating Voltage, Unpressurized

The minimum operating voltage measured during this test was within previously stated limits. The values ranged from 14.0 to 15.5 volts for valve S/N 007 and from 13.0 to 16.0 volts for valve S/N 008. Actual data for each cycle are recorded on Addendum pages D-35 and D-36.

##### 4.6.2 Minimum Operating Voltage, Pressurized

The minimum operating voltage with the valve pressurized with 100% HE to 50 psig fell within previously stated limits, and compared favorably with the data obtained in the unpressurized condition. The values ranged from 14.0 to 15.0 volts for valve S/N 007 and from 13.0 to 14.0 for valve S/N 008. The data are recorded in Addendum pages D-35 and D-36.

##### 4.6.3 Minimum Pulse Duration, Pressurized

The minimum pulse duration with the valve pressurized to 50 psig is within the previously specified limits. The values ranged from 30.0 to 38.0 ms for valve S/N 007 and from 36.0 to 38.0 ms for valve S/N 008. The results are listed on Addendum pages D-37 and D-38.

#### 4.6.4 Minimum Pulse Duration, Unpressurized

The minimum pulse duration with the test item in the unpressurized condition is within previously specified limits, and compares favorably with the pressurized condition. The values range from 33.0 to 38.0 for valve S/N 007 and from 36.0 to 37.0 for valve S/N 008. The results are listed on Addendum pages D-37 and D-38.

#### 4.6.5 Transient Pulses

This transient pulse test consisted of applying a steady state signal to one coil and a transient signal to the opposite coil. Acceptance criteria was that the valve would not change position when a transient signal was applied. Transient signals from +72 volts d. c., 5 microseconds, to -19 volts d. c., 9 milliseconds were applied to each coil of both valves. Microswitch pins A and E were monitored during all transient runs. Neither of the test items changed positions with the application of a voltage transient. The oscilloscope voltage traces from these tests are available in the test file.

Other transient pulse tests were run beyond the specification and test requirements. These involved applying a 72 volt d. c., 5 microsecond pulse one valve coil and zero volts on the alternate coil. This test was performed on all coils without inducing the valve poppet to change position. These test results are recorded on Addendum pages D-37 and D-38.

#### 4.6.6 Coil Transient Voltage

The coil transient voltage test was comprised of measuring the maximum peak inverse voltage when a 28.0 volt d. c. signal was removed from the coil. The peak inverse voltage is governed by the bifilar winding within the valve. The peak inverse voltage measured 50 volts for valve S/N007 and 52 volts for valve S/N008. The specified requirement is that the peak inverse voltage shall not exceed 150% of the applied voltage, or 42 volts for this test. Since the measured results exceeded the allowable value, a deviation request (form 847) was submitted to MSFC and approved. This request was numbered Avco - 010.

The performance of the valve when installed in the ATM Thermal Control System, however, is not discrepant, because the peak inverse voltage reflected back into the electrical control circuit has been reported as not exceeding 5 volts.

It was the intent of the specification, according to MSFC engineering, to measure the peak inverse voltage generated by the valve with the actual system control circuit. Since this system is complex, it is beyond the scope of the present contract. The peak inverse voltage data are recorded on Addendum pages D-39 and D-40.

#### 4.7 Life Cycling

A total to 1050 cycles were applied to valve S/N 007 and 1020 cycles to valve S/N 008. Cycling was accomplished with the valve filled with methanol/water and the switches resistively loaded to 3 amperes. The life cycle requirement is for 1000 cycles of operation. Functional

tests were performed after each 150 cycles. The results are summarized below.

#### 4.7.1 Internal Leakage

##### After 150 cycles

The poppet liquid leakage for both test items measured 0.0 sccs.

##### After 300 cycles

The poppet liquid leakage for both test items measured 0.0 sccs.

##### After 500 cycles

The poppet liquid leakage for both test items measured 0.0 sccs.

##### After 750 cycles

The poppet liquid leakage for valve S/N 008 measured 0.0 sccs and varied from 0.0 to 0.0008 sccs for valve S/N007.

##### After 1000 cycles

The poppet liquid leakage measured 0.0 sccs for valve S/N 008 and 0.01 sccs for valve S/N 007. These data are recorded on Addendum pages D-41, D-42, D-53 and D-54. Test requirements have been listed previously.

#### 4.7.2 Circuit Resistance

##### After 150 cycles

Circuit resistance measurements on both test items were between 0.0 and 0.2 ohms for continuous circuits, and infinity for open circuits. Coil resistances were within previously specified limits.

After 300 cycles

Same results as after 150 cycles.

After 500 cycles

Same results as after 150 cycles.

After 750 cycles

Same results as after 150 cycles.

After 1000 cycles

Same results as after 150 cycles. These data are recorded on Addendum pages D-43, D-44, D-55 and D-56.

4.7.3 Minimum Operating Voltage (Unpressurized)

The minimum operating voltage readings taken during life cycle testing with the test items unpressurized are summarized below. The readings represent the high and low measurements on each valve with a 100 ms pulse

After 150 cycles

<u>Valve S/N</u>	<u>Low (volt d. c.)</u>	<u>High (volt d. c.)</u>
007	12.0	14.5
008	12.5	13.5

After 300 cycles

<u>Valve S/N</u>	<u>Low (volt d. c.)</u>	<u>High (volt d. c.)</u>
007	12.0	14.5
008	14.0	14.5

After 500 cycles

<u>Valve S/N</u>	<u>Low (volt d. c.)</u>	<u>High (volt d. c.)</u>
007	14.0	16.0
008	14.0	15.0

After 750 cycles

<u>Valve S/N</u>	<u>Low (volt d. c.)</u>	<u>High (volt d. c.)</u>
007	14.5	17.0
008	15.0	16.0

After 1000 cycles

<u>Valve S/N</u>	<u>Low (volt d. c.)</u>	<u>High (volt d. c.)</u>
007	14.0	16.0
008	14.0	15.5

These results are recorded on Addendum pages D-45, D-46, D-61 and D-62. All readings are within specified limits, and do not indicate any degradation in performance of the valve as a result of life cycling.

4.7.4 Minimum Operating Voltage (Pressurized)

These tests are identical to the tests of 4.7.3 except that the test items were pressurized to 50 psig with 100% helium.

After 150 cycles

<u>Valve S/N</u>	<u>Low (volt d. c.)</u>	<u>High (volt d. c.)</u>
007	12.0	14.0
008	12.0	13.5

After 300 cycles

<u>Valve S/N</u>	<u>Low (volt d. c.)</u>	<u>High (volt d. c.)</u>
007	11.5	13.5
008	12.5	14.0

After 500 cycles

<u>Valve S/N</u>	<u>Low (volt d. c.)</u>	<u>High (volt d. c.)</u>
007	14.0	15.5
008	13.5	14.0

After 750 cycles

<u>Valve S/N</u>	<u>Low (volt d. c.)</u>	<u>High (volt d. c.)</u>
007	14.0	16.5
008	14.0	14.5

After 1000 cycles

<u>Valve S/N</u>	<u>Low (volt d. c.)</u>	<u>High (volt d. c.)</u>
007	14.0	16.0
008	14.0	14.5

The data are recorded on Addendum pages D-45, D-46, D-61 and D-62. All of the tests were within specified limits, and did not result in significant performance degradation.

4.7.5 Minimum Pulse Duration, Pressurized Assembly

The results of the periodic pulse duration tests performed during life cycling are summarized below. The tests were performed with the valve pressurized to 50 psig with 100% helium. The data represent the high and low readings for each valve independent of the coil being energized.

After 150 cycles

<u>Valve S/N</u>	<u>Low (ms)</u>	<u>High (ms)</u>
007	27.0	32.5
008	26.0	27.5

After 300 cycles

<u>Valve S/N</u>	<u>Low (ms)</u>	<u>High (ms)</u>
007	27.0	31.0
008	28.5	29.0

After 500 cycles

<u>Valve S/N</u>	<u>Low (ms)</u>	<u>High (ms)</u>
007	30.0	34.0
008	28.0	29.0

After 750 cycles

<u>Valve S/N</u>	<u>Low (ms)</u>	<u>High (ms)</u>
007	30.0	33.5
008	28.0	29.0

After 1000 cycles

<u>Valve S/N</u>	<u>Low (ms)</u>	<u>High (ms)</u>
007	27.5	32.0
008	28.0	28.5

The data are recorded on Addendum pages D47, D48, D63 and D-64.

4.7.6 Minimum Pulse Duration, Unpressurized Assembly

The results summarized below are identical to the tests of 4.7.5 except that the test items were unpressurized.

After 150 cycles

<u>Valve S/N</u>	<u>Low (ms)</u>	<u>High (ms)</u>
007	29.0	32.5
008	26.5	27.0

After 300 cycles

<u>Valve S/N</u>	<u>Low (ms)</u>	<u>High (ms)</u>
007	26.5	31.5
008	28.5	30.0

After 500 cycles

<u>Valve S/N</u>	<u>Low (ms)</u>	<u>High (ms)</u>
007	29.0	33.5
008	28.5	30.0

After 750 cycles

<u>Valve S/N</u>	<u>Low (ms)</u>	<u>High (ms)</u>
007	29.5	34.0
008	28.0	30.0

After 1000 cycles

<u>Valve S/N</u>	<u>Low (ms)</u>	<u>High (ms)</u>
007	27.0	31.5
008	28.0	28.5



The results of these tests are recorded on Addendum pages D-47, D-48, D-63 and D-64.

#### 4.7.7 Power Consumption During Life Cycling

The periodic power measurements taken at 28.0 volts d. c. during life cycling tests are summarized below. Values are the maximum measurements for each valve.

Valve S/N	Power (watts)				
	After 150 cycles	After 300 cycles	After 500 cycles	After 750 cycles	After 1000 cycles
007	28.0	28.2	28.2	28.1	28.2
008	31.0	30.5	31.0	31.0	31.0

Results of these tests are recorded on Addendum sheets D-49, D-50, D-63 and D-64.

#### 4.7.8 Proof Pressure After Life Tests

A 75.0 psig proof pressure test was applied to both test items for five minutes without evidence of distortion or permanent set. Test results are recorded on Addendum pages D-51 and D-52.

#### 4.7.9 Vacuum After Life Tests

A five minute vacuum test of less than  $1 \times 10^{-5}$  torr was applied to both test items without evidence of distortion or permanent set. Test results are recorded on Addendum pages D-51 and D-52.

#### 4.7.10 External Leakage After Life Tests

External leakage measurements on each test item with 50 psig, helium, were approximately two orders of magnitude better than the specified requirement. Test results are recorded on Addendum pages D-51 and D-52.

#### 4.7.11 Insulation Resistance After Life Tests

All insulation resistance measurements on each test item exceeded the requirement by more than three orders of magnitude. These measurements are recorded on Addendum pages D-55 through D-62.

#### 4.8 High Temperature Gaseous Tests

Both test items were placed in a chamber and allowed to stabilize at  $+165^{\circ}\text{F}$ . Each coil was energized for 5 continuous minutes at 30 volts d. c. Current measurements were made at the beginning and end of the period, and the coil resistance computed. The valves were allowed to return to  $165^{\circ}\text{F}$  and the valve operated. This procedure was repeated for a total of 10 cycles on each test unit. Resistance measurements at the beginning of each cycle were 30.9 ohms for each coil of valve S/N 007 and 33.3 ohms for each coil of valve S/N 008. Resistance measurements at the end of the five minute period were 35.7 ohms for each coil of valve S/N 007 and 37.5 ohms for each coil of valve S/N 008. The maximum valve body temperature reached with 30 volts d. c. applied to the valve was  $170^{\circ}\text{F}$  for S/N 007 and  $174^{\circ}\text{F}$  for S/N 008. The time required for the valve to cool to  $165^{\circ}\text{F}$  was 15 minutes for S/N 007 and 20-25 minutes for S/N 008. Results of these tests are recorded on Addendum pages D-65 and D-66.

##### 4.8.1 Internal Leakage After High Temp. Gaseous

With the test items stabilized at  $+100^{\circ}\text{F}$  and pressurized as previously described with methanol/water, the measured poppet leakage for each unit was 0.0 sccs. Test results are recorded on Addendum pages D-67 and D-68.

#### 4.8.2 Circuit Resistance After High Temp. Gaseous

Circuit measurements were made with the valve stabilized at +100°F. Continuous circuits on both test items, did not exceed 0.2 ohms and open circuits measured infinite resistance. Coil resistances were slightly higher than room temperature measurements. All of the data were within acceptable limits. Results are recorded on Addendum pages D-67, D-68, D-69 and D-70.

#### 4.8.3 Insulation Resistance After High Temp. Gaseous

Insulation resistance measurements were made with the valves stabilized at +100°F. All measurements exceeded the minimum requirement of 50 megohms minimum. Most of the values exceeded the minimum requirement by three orders of magnitude or more, but a few were only slightly higher than minimum. The data are recorded on Addendum pages D-69 through D-76.

#### 4.8.4 Minimum Voltage After High Temp. Gaseous (Unpressurized)

Minimum voltage measurements were made with the valve stabilized at +100°F. The values were slightly higher than at room temperature, but were all within previously specified limits. The minimum voltage varied from 16.5 to 18.0 volts d.c. for valve S/N 007 and from 16.0 to 17.0 volts for valve S/N 008. Results of the test are recorded on Addendum pages D-75 and D-76

#### 4.8.5 Minimum Voltage After High Temp. Gaseous, Pressurized

The test described in 4.8.4 was repeated with the test items pressurized to 50 psig with helium. Test results were within previously specified requirements, and slightly lower than for the unpressurized condition. The voltage readings for S/N 007 varied from 14.5 to 16.5 volts d. c. and for unit S/N 008 from 15.5 to 16.0 volts d. c. Test data are recorded on Addendum pages D-77 and D-78.

#### 4.8.6 Pulse Duration After High Temp. Gaseous, Pressurized

Minimum pulse duration tests were run with the valve stabilized at +100°F and pressurized to 50 psig with 100% helium. All results were well within the acceptable values. The results for valve S/N 007 ranged from 28.0 to 32.0 volts ms, and from 27.5 to 29.0 for valve S/N 008. Test data are recorded on Addendum pages D-77 and D-78.

#### 4.8.7 Pulse Duration After High Temp. Gaseous, Unpressurized

The test described in 4.8.6 was performed with the test items in the unpressurized condition. Performance for both test items was acceptable. The minimum pulse duration for valve S/N 007 ranged from 27.5 to 32.5 v ms, and for S/N 008 from 28.5 to 30.0 volts d. c. Test data are recorded on addendum pages D-77 and D-78.

#### 4.8.8 Power After High Temperature Gaseous

Power measurements were made with the valves stabilized at +100°F. The power consumption for both test items was slightly lower than the performance at room temperature, because of the increase coil resistance with temperature. The maximum value was 26.3 watts for

S/N 007 and 28.6 watts for S/N 008. Values for each coil are recorded on Addendum pages D-79 and D-80.

#### 4.9.0 Low Temperature Gaseous

The two test items were placed in a cold chamber and allowed to stabilize at  $-65^{\circ}\text{F}$  for a period exceeding 48 hours. After the cold soak, the functional tests listed below were performed.

##### 4.9.1 External Leakage at $-65^{\circ}\text{F}$

The external leakage measurement for both test units at  $-65^{\circ}\text{F}$  was better than the allowable value by two orders of magnitude or more. The helium leakage rate was  $0.7 \times 10^{-8}$  sccs for S/N 007 and  $1.44 \times 10^{-8}$  for S/N 008. Results are recorded on Addendum pages D-79, D-80,

##### 4.9.2 Internal Leakage at $-65^{\circ}\text{F}$

Poppet leakage was measured with the test items stabilized at  $-65^{\circ}\text{F}$ . Both valves were well within specified limits. Zero leakage was measured for valve S/N 008 and values ranging from 0 to 0.0033 sccs of the liquid service media for valve S/N 007. These data are recorded on addendum pgs. D-78, D-79, D-80 and D-81.

##### 4.9.3 Circuit Resistance at $-65^{\circ}\text{F}$

Circuit resistance measurements at  $-65^{\circ}\text{F}$  did not vary significantly from measurements at room temperature, except for coil resistance measurements. Closed circuit measurements did not exceed 0.2 ohms. Open circuit measurements indicated infinite resistance. Coil resistance for S/N 007 was approximately 20 ohms and 17.9 ohms for S/N 008. All circuit resistance values were within acceptable limits. These measurements are recorded in Addendum pgs. D81 & D82

##### 4.9.4 Insulation Resistance at $-65^{\circ}\text{F}$

Insulation resistance measurements on both test items were somewhat degraded from the values recorded at room temperature, but all values exceed the specified requirement. The lowest insulation resistance measurement was 200 megohms. The data are recorded on Addendum pages D-83 through D-88.

#### 4.9.5 Minimum Operating Voltage, at -65°F, Gaseous Unpressurized

The minimum operating voltages for both test items, unpressurized, at -65°F were significantly lower than at room temperature because of the higher current drain. Performance ranged between 12.0 and 13.0 volts d. c. for valve S/N 007 and 13.0 volts d. c. for all measurements made on S/N 008. Actual results are shown on Addendum pages D-89 and D-90.

#### 4.9.6 Minimum Operating Voltage, at -65°F Gaseous Pressurized

The performance of both test items pressurized to 50 psig with 100% helium was comparable to the unpressurized condition. Valve S/N 007 operated at 12.0 volts d. c. and S/N 008 at 13.0 volts d. c. for all readings. Actual results are shown on Addendum pages D-89 and D-90.

#### 4.9.7 Minimum Pulse Duration at -65°F, Gaseous, Pressurized

The minimum pulse duration readings of the test items stabilized at -65°F were significantly lower than they were at room temperature. The pulse measurements ranged from 14.0 to 16.0 ms. for valve S/N 007, and from 23.0 to 25.0 ms for valve S/N 008. These readings are shown on Addendum pages D-91 and D-92.

#### 4.9.8 Minimum Pulse Duration at -65°F, Gaseous, Unpressurized

The minimum pulse duration readings at -65°F with the valve in the unpressurized condition were only slightly higher than in the pressurized condition, but well within acceptable limits. These measurements ranged from 15.0 to 20.0 ms for the S/N 007 valve, and from 25.0 to 26.0 ms for valve S/N 008. The readings are shown on Addendum pages D-91 and D-92.

#### 4.9.9 Power, at -65°F

The highest power readings were encountered as a result of the lower coil resistance with the valve stabilized at -65°F.

The maximum power consumption was 36.4 watts for S/N 007 and 40.9 watts for S/N 008. The allowable value is 45 watts maximum. Test results are shown on Addendum pages D-91 and D-92.

#### 4.10 After High and Low Temperature Gaseous

At the conclusion of the cold temperature performance tests, the test items were returned to room temperature and the complete series of functional tests performed as described below:

##### 4.10.1 External Leakage After High/Low Temp. Gaseous

External leakage measurements on both test items with 100% helium were well within tolerance. The value was  $3.46 \times 10^{-8}$  sccs for S/N 007 and  $11.25 \times 10^{-8}$  sccs for S/N 008. Records of this test are shown on Addendum page D-93 and D-94.

##### 4.10.2 Internal Leakage After High/Low Temp. Gaseous

Internal leakage measurements with methanol/water service media were 0.0 sccs for both test items. Results of this test are recorded on Addendum pages D-93 and D-94.

##### 4.10.3 Circuit Resistance After High/Low Temp. Gaseous

Closed circuit resistance readings did not exceed 0.3 ohms for valve S/N 007 and 0.4 ohms for S/N 008. Open circuit readings indicated infinite resistance for both valves, and coil resistance readings were within acceptable limits. These readings are recorded on Addendum pages D-95 and D-96.

#### 4.10.4 Insulation Resistance After High/Low Temp., Gaseous

All of the insulation resistance readings for each valve taken after high and low temperature testing were well in excess of 50 megohms, the minimum allowable value. These readings are recorded on Addendum pages D-97 through D-104.

#### 4.10.5 Minimum Operating Voltage After High/Low Temp. Gaseous, Unpressurized

The minimum operating voltage after high and low temperature testing was comparable to previous room temperature results, and was within acceptable limits. The values were between 16.0 and 17.0 volts d. c. for valve S/N 007 and between 15.0 and 16.0 volts d. c. for valve S/N 008. Results of these tests are recorded on Addendum pages D-103 and D-104.

#### 4.10.6 Minimum Operating Voltage After High/Low Temperature Gaseous, Pressurized.

The minimum operating voltage with the valve pressurized to 50 psig is slightly lower than in the unpressurized condition, and is comparable to previously obtained room temperature data. The values ranged from 15.0 to 15.5 volts d. c. for valve S/N 007 and from 15.0 to 15.5 volts d. c. for valve S/N 008. The data are recorded on Addendum pages D-103 and D-104.

#### 4.10.7 Minimum Pulse Duration After High/Low Temp. Gaseous, Pressurized

The minimum pulse duration performance of either valve did not seem to be changed as a result of the high and low thermal tests. The results were well within tolerance and ranged from 26.0 to 29.0 ms for both test items. The data are recorded on Addendum pages D-105 and D-106.



#### 4.10.8 Minimum Pulse Duration After High/Low Temp. Gaseous Unpressurized

The minimum pulse duration for the valves in the unpressurized condition ranged from 25.0 to 29.0 ms for S/N 007 and from 27.5 to 30.0 for valve S/N 008. The data are recorded on Addendum pages D-105 and D-106.

#### 4.10.9 Power After High/Low Temp. Gaseous

The power consumption of both test items showed negligible change as a result of the high and low thermal environment. The maximum power drain for valve S/N 007 was 27.72 watts, and for S/N 008 29.96 watts. These results are recorded on Addendum pages D-105 and D-106.

#### 4.11 High Temperature Liquid, +100°F

Both test items were filled with the liquid service media, placed in a chamber, and allowed to stabilize at +100°F. The functional tests described below were then performed.

##### 4.11.1 Internal Leakage at 100°F, Liquid

The poppet leakage test was identical to the internal leakage test of 4.8.1 and the results were essentially identical. Liquid leakage on valve S/N 007 ranged from 0.0 to 0.016 sccs of the service media, and was 0.0 sccs for valve S/N 008. Results of this test are recorded on Addendum pages D-107 and D-108

##### 4.11.2 Circuit Resistance at +100°F, Liquid

Circuit resistance measurements with the valve filled with the liquid service media were within acceptable limits. The closed circuit

values did not exceed 0.4 ohms for either test item. Open circuit resistance measurements indicated infinite resistance. Coil resistance readings basically the same as for the gaseous test at +100°F. Results are recorded on Addendum pages D-107, D-108, D-109 and D-110.

#### 4.11.3 Insulation Resistance at +100°F, Liquid

Insulation resistance measurements on both valves were satisfactory during this test. All measurements were in excess of 50 megohms. The resistance readings are recorded on Addendum pages D-109 through D-116.

#### 4.11.4 Minimum Voltage at +100°F, Liquid, Unpressurized

The minimum voltage readings for this test are approximately the same as for the gaseous condition at +100°F, para. 4.8.4, and fell within specified tolerances. The values ranged from 16.0 to 18.0 volts d. c. for valve S/N 007, and from 17.0 to 17.9 volts d. c. for valve S/N 008. These data are recorded on Addendum pages D-115 and D-116.

#### 4.11.5 Minimum Voltage at 100°F, Liquid, Pressurized

The minimum voltage readings with the methanol/water pressurized to 50 psig is about the same as for the unpressurized condition. The values ranged from 16.5 to 17.5 volts d. c. for S/N 007 and from 17.5 to 17.9 volts d. c. for valve S/N 008. These data are recorded on Addendum pages D-115 and D-116.

#### 4.11.6 Pulse Duration at +100°F, Liquid, Pressurized

The minimum pulse duration with the liquid service media pressurized to 50 psig, was slightly higher than the corresponding tests, para. 4.8.6 with gas pressure. Performance was still well within acceptable limits. The measurements ranged from 28.0 to 34.0 ms for valve S/N 007 and from 30.0 to 33.0 ms for valve S/N 008. Results of this test are recorded on Addendum pages D-117 and D-118.

#### 4.11.7 Pulse Duration at +100°F, Liquid, Unpressurized

The test described in 4.11.6 was performed in the unpressurized condition. Results ranged from 26.5 to 28.0 ms for valve S/N 007 and from 28.0 to 34.0 for valve S/N 008. Test data are recorded on Addendum pages D-117 and D-118.

#### 4.11.8 Power at +100°F, Liquid

Power measurements with the test items filled with methanol/water comparable to the same test under gaseous conditions. The maximum power consumption was 26.4 and 28.5 watts respectively for valve S/N 007 and 008. Actual readings are recorded on Addendum pages D-117 and D-118.

#### 4.12 Low Temperature, Liquid, -65°F

Both test items, (filled with the liquid service media), were allowed to stabilize at -65°F and the functions tests listed below performed.

##### 4.12.1 Internal Leakage at -65°F, Liquid

Both test items measured 0 sccs of the liquid service media after stabilization at -65°F. Test results are recorded on Addendum pages D-119 and D-120.

#### 4.12.2 Circuit Resistance at -65°F, Liquid

Circuit measurements, made during this cold test were all within acceptable limits. Closed circuit resistances did not exceed 0.4 ohms. Open circuit measurements indicated infinite resistance. Coil resistances were significantly lower than room temperature and nearly identical to the previous -65°F test readings. Readings for this test are recorded on Addendum pages D-119, D-120, D-121 and D-122.

#### 4.12.3 Insulation Resistance at -65°F, Liquid

None of the the insulation resistance readings taken during this cold test was below the permissible 50 megohms minimum. These readings are recorded on Addendum pages D-121 through D-128.

#### 4.12.4 Minimum Operating Voltage at -65°F, Liquid, Unpressurized

The minimum operating voltage at cold temperature is lower than at room temperature due to the higher current drain. Performance of the test items filled with liquid is similar to the gaseous test run at -65°F. The readings ranged from 12.0 to 15.0 volts d. c. for valve S/N 007 to 11.0 to 12.0 volts d. c. for valve S/N 008. The data are recorded on Addendum pages D-127 and D-128.

#### 4.12.5 Minimum Operating Voltage at -65°F, Liquid, Pressurized

The performance of the test items with the liquid service media pressurized to 50 psig was comparable to the unpressurized condition. The readings ranged from 12.0 to 14.0 volts d. c. for valve S/N 007 and from 12.0 to 13.0 for valve S/N 008. The data are recorded on Addendum pages D-127 and D-128.

#### 4.12.6 Minimum Pulse Duration at -65°F, Liquid, Pressurized

The minimum pulse duration for this test was in the same range as previously obtained room temperature data and still within allowable limits. The measurements ranged from 31.0 to 37.0 ms for valve S/N 007 and from 30.0 to 32.0 ms for valve S/N 008. The readings are recorded on Addendum pages D-129 and D-130.

#### 4.12.7 Minimum Pulse Duration at -65°F, Liquid, Unpressurized

The pulse duration in the pressurized condition for both test items was somewhat lower than the pressurized case. These values ranged from 27.0 to 30.0 volts d. c. for valve S/N 007 and from 26.0 to 28.0 volts d. c. for valve S/N 008. The readings are recorded on Addendum pages D-129 and D-130.

#### 4.12.8 Power at -65°F, Liquid

The power consumption of both test items at 28 vdc, during this test was below the allowable 45 watts, and was nearly identical to the results of the previous test at -65°F. The maximum power drain was 37.5 watts for S/N 007 and 40.6 watts for S/N 008. The results are shown on Addendum pages D-129 and D-130.

#### 4.13 After High and Low Temperature, Liquid

At the completion of the high and low thermal tests, a complete series of functional tests were conducted as outlined below.

##### 4.13.1 External Leakage After High/Low Temp., Liquid

External leakage rates for both test items after thermal testing was within specified limits. The leakage was  $1.69 \times 10^{-7}$  sccs He

for valve S/N 007, and  $5.5 \times 10^{-8}$  sccs He for S/N 008. Records of this test are shown on Addendum pages D-131 and D-132.

#### 4.13.2 Internal Leakage After High/Low Temp., Liquid

Poppet liquid leakage at the completion of thermal testing was still well within acceptable limits. The values ranged from 0 to 0.02 sccs for valve S/N 007 and was 0 sccs for all measurements on Valve S/N 008. Records of this test are shown on Addendum pages D-131 and D-132.

#### 4.13.3 Circuit Resistance After High/Low Temp., Liquid

The results of this test were equal to or better than previous room temperature circuit resistance measurements. The maximum closed circuit resistance on either test item was 0.1 ohm. Open circuit readings all indicated infinite resistance, and coil resistances were nearly equal to previous room temperature measurements. The test records are shown on Addendum pages D-133 and D-134.

#### 4.13.4 Insulation Resistance, After High/Low Temp., Liquid

Insulation resistance measurements at 500 volts d. c. on both test items were well in excess of the 50 megohm minimum requirement. These readings are recorded on Addendum pages D-135 through D-142.

#### 4.13.5 Minimum Voltage, After High/Low Temp., Liquid, Unpressurized

The minimum operating voltage performance of both valves in the unpressurized condition was consistent with previous room temperature performance. Voltage readings ranged from 16.0 to 17.0 volts d. c. for both test items. The data are shown on Addendum pages D-141 and D-142.

4.13.6 Minimum Voltage After High/Low Temp., Liquid Pressurized

Performance of the test items while pressurized to 50 psig with helium is similar to the unpressurized condition. The voltage readings ranged from 16.0 to 17.0 volts d. c. for the S/N 007 valve, and from 16.0 to 16.5 volts d. c. for S/N 008. The data are shown on Addendum pages D-141 and D-142.

4.13.7 Minimum Pulse Duration After High/Low Temp., Liquid, Pressurized

Minimum pulse duration performance of both items in the pressurized condition was slightly higher after than before thermal testing, but all readings are well within the specified values. The pulse width readings ranged from 31.0 to 34.0 ms for valve S/N 007, and from 32.0 to 34.0 for valve S/N 008. Actual measurements are shown on Addendum pages D-143 and D-144.

4.13.8 Minimum Pulse Duration, After High/Low Temp., Liquid, Unpressurized

The minimum operating pulse width in the unpressurized condition is consistent with the pressurized case. The pulse readings ranged from 31.0 to 35.0 ms for valve S/N 007, and from 33.0 to 34.0 for S/N 008. Actual measurements are recorded on Addendum pages D-143 and D-144.

4.13.9 Power After High/Low Temp., Liquid

The power drain of both test items at the conclusion of

high/low thermal testing showed that the valve coils were not affected by previous testing. The maximum power consumption was 27.4 watts for S/N 007 and 29.9 watts for S/N 008. The results of these tests are listed on Addendum pages D-143 and D-144.

#### 4.14 Full Flow

This test consisted of performing operational tests on both test items while flowing 900 lb/hr of the liquid media through the valve. The results of the functional tests are described below.

##### 4.14.1 Pressure Drop

Pressure drop measurements were made with flow in both the forward and reverse directions through the valves. Overall results are listed below.

##### $\Delta P$ Range, PSI

Valve S/N	Port A-C	Port B-C	Port C-A	Port C-B
007	0.23-0.36	0.22-0.32	0.32-0.38	0.40-0.45
008	0.38-0.49	0.25-0.34	0.38	0.22-0.35

The specified limit for this test is 0.5 psi. The results of the test are recorded on Addendum pages D-145 and D-146.

##### 4.14.2 Circuit Resistance During Full Flow

The circuit resistance readings during this test were comparable to data collected previously. The closed circuit readings ranged from 0.1 to 0.5 ohms. Open circuit readings indicated infinite resistance. Coil measurements ranged between 27.6 and 28.9 ohms. The data are recorded on Addendum pages D-145 and D-146.



#### 4.14.3 Minimum Operating Voltage During Full Flow

The minimum operating voltage results were characteristic of previous performance with test items filled with gas. The values ranged from 15.0 to 16.0 volts d. c. for both test items. The data are recorded on Addendum pages D-147 and D-148.

#### 4.14.4 Minimum Pulse Duration During Full Flow

The minimum pulse duration was also comparable to previous data under gaseous conditions. The values ranged from 30.0 to 36.0 ms for valve S/N 007 and from 30.0 to 35.0 ms for Valve S/N 008. The data are recorded on Addendum pages D-149 and D-150.

#### 4.14.5 Power During Full Flow

The power drain with liquid flowing through the test items was nearly identical to previously collected data. The maximum power consumption was 27.2 watts for valve S/N 007 and 28.9 watts for S/N 008. Records of this test are shown on Addendum pages D-149 and D-150.

#### 4.15 Humidity

Valve S/N 008 was subjected to 95% R. H. 243 hour humidity test. The test item was completely uncovered, and was not operated while exposed to the humidity environment. An exposure of 240 hours was required. At the conclusion of the test period, the valve was visually examined and no damage or corrosion found. Before one hour had elapsed at the conclusion of the humidity test, the functional tests outlined below were begun.

#### 4.15.1 External Leakage After Humidity

Helium leakage with the valve pressurized to 50 psig was within specified limits. Test records are shown on Addendum page D-151.

#### 4.15.2 Internal Leakage After Humidity

Poppet leakage rates with the liquid service media measured 0.0 sccs for each poppet position. Records are shown on Addendum page D-151.

#### 4.15.3 Circuit Resistance After Humidity

Circuit resistance measurements were all within specified tolerances after being subjected to the humid environment. Closed circuit readings ranged from 0.1 to 0.5 ohms, and open circuit readings indicated infinite resistance. Actual readings are listed on addendum page D-152.

#### 4.15.4 Insulation Resistance After Humidity

Circuit insulation remained in tact after humidity testing. All measurements exceeded the 50 megohm minimum requirement. Records of this test are shown on Addendum pages D-153 to D-156.

#### 4.15.5 Minimum Voltage After Humidity, Unpressurized

The minimum operating voltage performance of the valve was unaffected by the humidity test. The values ranged from 15.0 to 16.0 volts d. c. Actual measurements are recorded on Addendum page D-156.

#### 4.15.6 Minimum Voltage After Humidity, Pressurized

Performance of the valve in the pressurized condition was similar to the unpressurized condition. These values ranged from 14.0 to 16.0 volts d. c., and are recorded on Addendum page D-156.

#### 4.15.7 Minimum Pulse Duration After Humidity, Pressurized

The minimum pulse width performance was also unaffected by humidity testing. The minimum pulse duration in the pressurized condition varied from 27.0 to 32.0 ms. The data are recorded on Addendum page D-157.

#### 4.15.8 Minimum Pulse Duration after Humidity, Unpressurized

The unpressurized performance of the valve was comparable to that for the pressurized condition. Values varied from 28.0 to 32.0 ms and are recorded on Addendum page D-157.

#### 4.15.9 Power After Humidity

The power consumption for the valve after the humidity test was not significantly different from previous measurements, and was well below the 45 watt maximum allowable. The maximum power readings was 29.9 watts, and is recorded on Addendum page D-157.

#### 4.16 Collapse Pressure Test

A collapse pressure test was performed on valve S/N 008 by placing the valve in a chamber and pressurizing the chamber to 19.0 psig for 3 minutes. The internal pressure of the valve was monitored, and remained at 0 psig. There was no visual evidence of

collapse or permanent deformation after application of pressure. The valve was successfully operated after visual examination. Records of this test are shown on Addendum page D-158.

#### 4.17 Burst Pressure

A burst pressure test was conducted on valve S/N 008 by pressurizing the valve ports hydrostatically to 125 psig for 3 minutes. The test item was visually examined for deformation and then successfully operated. There was no evidence of distortion or permanent set.

The valve was subsequently pressurized to destruction. The suspension diaphragm failed at 450 psig, followed by the valve cover at 2000 psig. The suspension diaphragm developed cracks at the maximum stress point, which is at the inner radius. The cover failed at the weld joint with the valve body. Photographs of the failure points are included in Addendum E. Results of the test are recorded on Addendum page D-158.

#### 4.18 Thermal Cycling

Valve S/N 007 was subjected to 203 consecutive thermal cycles. One cycle consisted of heating the test item until it stabilized at +120°F, then cooling it until it stabilized at 0°F, and then returning it to +120°F. The length of a thermal cycle was approximately 55 minutes. The valve was not operated during the thermal cycles. At the conclusion of this test, the valve was returned to room temperature and functional tests performed.

##### 4.18.1 External Leakage After Thermal Cycling

The helium leak rate of valve S/N 007 was well within specified limits after thermal cycling. The leak rate was  $.72 \times 10^{-6}$  and

is recorded on Addendum page D-160.

#### 4.18.2 Internal Leakage After Thermal Cycling

Poppet liquid leakage was not affected by thermal cycling. The leak rate from both ports measured 0.0 sccs of the liquid service media. The data are recorded on Addendum page D-160.

#### 4.18.3 Circuit Resistance After Thermal Cycling

Circuit resistance readings after thermal cycling were consistent with previously obtained data. Closed circuit resistance ranged from 0 to 0.5 ohms. Open circuit measurements indicated infinite resistance. Coil resistances averaged 27.9 ohms for one coil and 28.1 ohms for the other. These electrical measurements are recorded on Addendum pages D-161.

#### 4.18.4 Insulation Resistance After Thermal Cycles

Circuit insulation did not exhibit any degradation as a result of thermal cycle testing. All insulation readings exceeded the specified 50 megohms minimum resistance. The data are recorded on Addendum pages D-162 to D-165.

#### 4.18.5 Minimum Voltage After Thermal Cycling Unpressurized

The minimum voltage in the unpressurized condition remained well within acceptable limits. The values ranged from 16.0 to 17.0 volts d.c. Results of the test are listed on Addendum page D-165.

#### 4.18.6 Minimum Voltage After Thermal Cycling, Pressurized

The minimum voltage in the pressurized condition (50 psig) was satisfactory. The measurements were between 15.0 and 17.0 volts d.c. Test results are recorded on Addendum pages D-165.

#### 4.18.7 Minimum Pulse Duration After Thermal Cycling, Pressurized.

The minimum pulse duration data after thermal cycling was representative. Values ranged from 30.0 to 33.0 ms. Results are shown on Addendum page D-166.

#### 4.18.8 Minimum Pulse Duration After Thermal Cycling, Unpressurized

Minimum pulse duration in the unpressurized condition for the valve ranged from 30.0 to 32.0 ms. Results are shown on Addendum page D-166.

#### 4.18.9 Power After Thermal Cycling

The power drain for valve S/N 007 did not change with thermal cycling. The maximum value was 27.4 watts, and is recorded on Addendum page D-166.

STP-SSD-1024

QUALIFICATION TEST PROCEDURE FOR ATM TEMPERATURE  
CONTROL SYSTEM FLOW PATH SELECTOR VALVE

MSFC Spec. No. 20M42517  
Hydraulic Research & Mfg. Dwg. No. 3900750

Contract NAS8-30075

Prepared for

National Aeronautics and Space Administration  
George C. Marshall Space Flight Center  
Huntsville, Alabama

Prepared by

Avco Applied Technology Division  
Auxiliary Propulsion Department  
Lowell, Massachusetts 01851

4 December 1969

## Table of Contents

Title Page	i	
Signature	ii	
Revision Page	iii	
Table of Contents	iv	
List of Figures	v	
1.0	Introduction	
2.0	Applicable Documents	
3.0	Test Requirements	
4.0	Component Description	
5.0	Procedure	
5.1	Pre-Test Examination	
5.2	Test Summary	
5.3	Functional Test	
5.3.1	Proof Pressure	
5.3.2	Leakage, External	
5.3.3	Leakage, Internal	
5.3.4	Acceptance Vibration	
5.3.5	Vacuum, Internal	
5.3.6	Proof Pressure	
5.3.7	Leakage, External	
5.3.8	Leakage, Internal	
5.3.9	Circuit Resistance	
5.3.10	Insulation Resistance	
5.3.11	Minimum Operating Voltage (Unpressurized)	
5.3.12	Minimum Operating Voltage (Pressurized)	
5.3.13	Minimum Pulse Duration (Pressurized)	
5.3.14	Minimum Pulse Duration (Unpressurized)	
5.3.15	Power Consumption	
5.4	Acoustic Noise	
5.4.1	Leakage Internal, Liquid	
5.5	Vibration	
5.6	Transient Pulses	
5.7	Life Cycling	
5.8	High and Low Temperature	
5.9	Full Flow	
5.10	Humidity	
5.11	Salt Fog	
5.12	Sand and Dust	
5.13	Fungus	



Table of Contents (Concl'd)

- 5.14 . Collapse Pressure
- 5.15 Burst Pressure
- 5.16 Temperature Cycling
- 5.17 Compatibility
- 6.0 Test Instrumentation and Equipment
- 7.0 Notes

Appendix A - Test Schematics

List of Figures

<u>Figure No.</u>	<u>Title</u>
1	Proof and External Leakage Test
2	Internal Leakage Test, Gaseous
3	Vibration Test
4	Vacuum Test
5	Minimum Operating Voltage Test, Minimum Pulse Duration Test
6	Power Consumption Test
7	Internal Leakage Test, Liquid
8	Transient Pulses
9	Life Cycling Test
10	High and Low Temperature, and Temperature Cycling Test
11	Full Flow Test
12	Collapse Pressure Test
13	Burst Pressure Test
14	Compatibility Test
15	Humidity Test

## 1.0 Introduction

The purpose of this test program is to determine the ability of an Electrical Pulse Operated Flow Path Selector Valve, Hydraulic Research drawing 39000750, to meet the qualification requirements of NASA/MSFC specification number 20M42517.

### 1.1 Scope

This document establishes the qualification test procedure to qualify the Flow Path Selector Valve for use in the ATM thermal control system.

## 2.0 Applicable Documents

### 2.1 Applicability

The test program contained herein is based on the following documents of the issue indicated.

#### 2.1.1 Specifications

NASA/MSFC Spec. 20M42517 - Valve Assembly Flow Path Selector, Electrical Pulse Operated Design Procurement Drawing.

MSFC Spec. 164 - Cleanliness of Components for use in Liquid Oxygen, Fuel and Pneumatic Systems, Specification For.

MSFC Dwg. 20M42501 - Methanol/Water ATM TCS.

NPC 200-2 - Quality Program Provisions for Space Systems Suppliers.

NPC 200-3 - Inspection Systems Provisions for Suppliers of Space Materials.

#### 2.1.2 Standards

MIL-STD-810A - Environmental Test Methods for Aerospace and Ground Equipment.

MIL-STD-831 - Test Reports, Preparation Of.

2.1.3 Drawings

Hydraulic Research 39000750 - Valve Assembly--  
Latching complete.

Hydraulic Research 39000751 - Valve Assembly--  
Latching.

MSFC Dwg. 50M02408A - Environmental Design and  
Qualification Test Criteria for Apollo Telescope Mount Components.

3.0 Test Requirements

3.1 Tolerances

3.1.1 Environmental Tolerances

Unless otherwise indicated herein, the maximum  
allowable deviation from special environmental conditions are as follows:

a.	Temperature	$\pm 2^{\circ}\text{F}$
b.	Relative Humidity	$\pm 5\%$
c.	Flow	$\pm 1\%$
d.	Vibration <u>Sine</u>	
	Amplitude	$\pm 10\%$
	Frequency	$\pm 5\%$
	Test Duration	$+10\%$
		- 0
e.	Vibration Random	
	Overall Root Mean Square Acceleration	$\pm 10\%$
	Acceleration Power Spectral Density	$+100\%$
		- 30%
f.	Pressure	
	Static	$\pm 1.0\%$
	Dynamic	$\pm 3.0\%$

3.1.2 Measurement Tolerance

The maximum allowable equipment measurement  
errors shall be as follows:

a.	Temperature	$\pm 30^{\circ}\text{F}$
b.	Relative Humidity	2.5%
c.	Flow	$\pm 2.5\%$

d.	Vibration	
	Amplitude	±5%
	Frequency	±2%
e.	Pressure	
	Static	±1.0%
	Dynamic	±3.0%

### 3.1.3 Ambient Conditions

Unless otherwise specified, all tests shall be conducted at the ambient conditions defined below:

a.	Temperature	77±18°F
b.	Relative Humidity	90% or less
c.	Pressure - Sea level to 24.05 in. Ag Abs.	

### 3.2 Failure Definition

The established specification shall be considered the operational requirements for the Qualification Program.

3.2.1 Whenever the test assembly deviates from the requirements of this procedure, failure determination shall be made.

3.2.2 In any case, where the test assembly is physically impaired from performing as required, the operational requirements shall be reviewed and a failure determination made. After incorporation of any changes or procurements of new specimens is complete, the specimen shall be subjected to as many parts of the qualification test procedure as deemed necessary. Additional tests are to be agreed upon in writing by R-P&VE-PM, R-P&VE-PEM, and Avco Applied Technology Division.

### 3.3 Deviations

No changes shall be made in the requirements of the test procedure without mutual agreement in writing by R-P&VE-PM, and R-P&VE-PEM, and Avco Applied Technology Division.

### 3.4 Final Report

Avco Applied Technology Div. shall be responsible for the preparation of the final report. The report shall be a complete and concise record of all phases of testing with applicable data obtained from the test program.

### 3.5 Data Recording

The results of inspection tests, discrepancies, and deviations shall be entered on the appropriate data sheets in the data section of this procedure. Each paragraph involving inspection or test has a corresponding paragraph in the data section for recording of comments and/or data.

### 3.6 Location of Test Facilities

All of the testing will be performed at Avco's Lowell and Wilmington, Massachusetts, facilities with exception of the Acoustic Noise test which will be performed by Noise Unlimited of Sommerville, New Jersey.

### 4.0 Component Description

The flow path selector valve is a two position switching valve which diverts flow from either of two inlet ports to a common outlet port upon receipt of an electrical pulse. The flow valves are connected in a redundant network to direct flow to either the heating or cooling section of the Apollo Telescope Mount Temperature Control System. The redundant flow valves are operated by temperature controllers that modulate the diverter valves on the basis of inlet temperature to the portion of the system which is being controlled.

The valve is composed basically of an armature, two permanent magnet poles, a flapper type suspension member, a poppet, two micro-switches and a housing. The armature is located between the two permanent magnets, and separated from these magnets by a small air gap. The armature is composed of a metal core around which 3 coils are wound in a bifilar manner. The armature is structurally part of the flapper which is attached to the poppet. The poppet is held in either of two positions by virtue of the permanent magnets, and a pivot (suspension plate) located between the armature and the poppet.

When one of the bifilar windings is appropriately energized, a magnetic potential is developed across the armature which opposes and overcomes the permanent magnet potential to drive the poppet in the opposite direction. As the armature is unlatched, the opposite permanent magnet attracts the armature to switch the valve from one position to the other, and therefore close the opposite port. Due to the symmetry of construction, the secondary position is identical to the primary position. The third winding has the ends of the coil shorted and is used as an inverse voltage suppression winding for the two power windings.

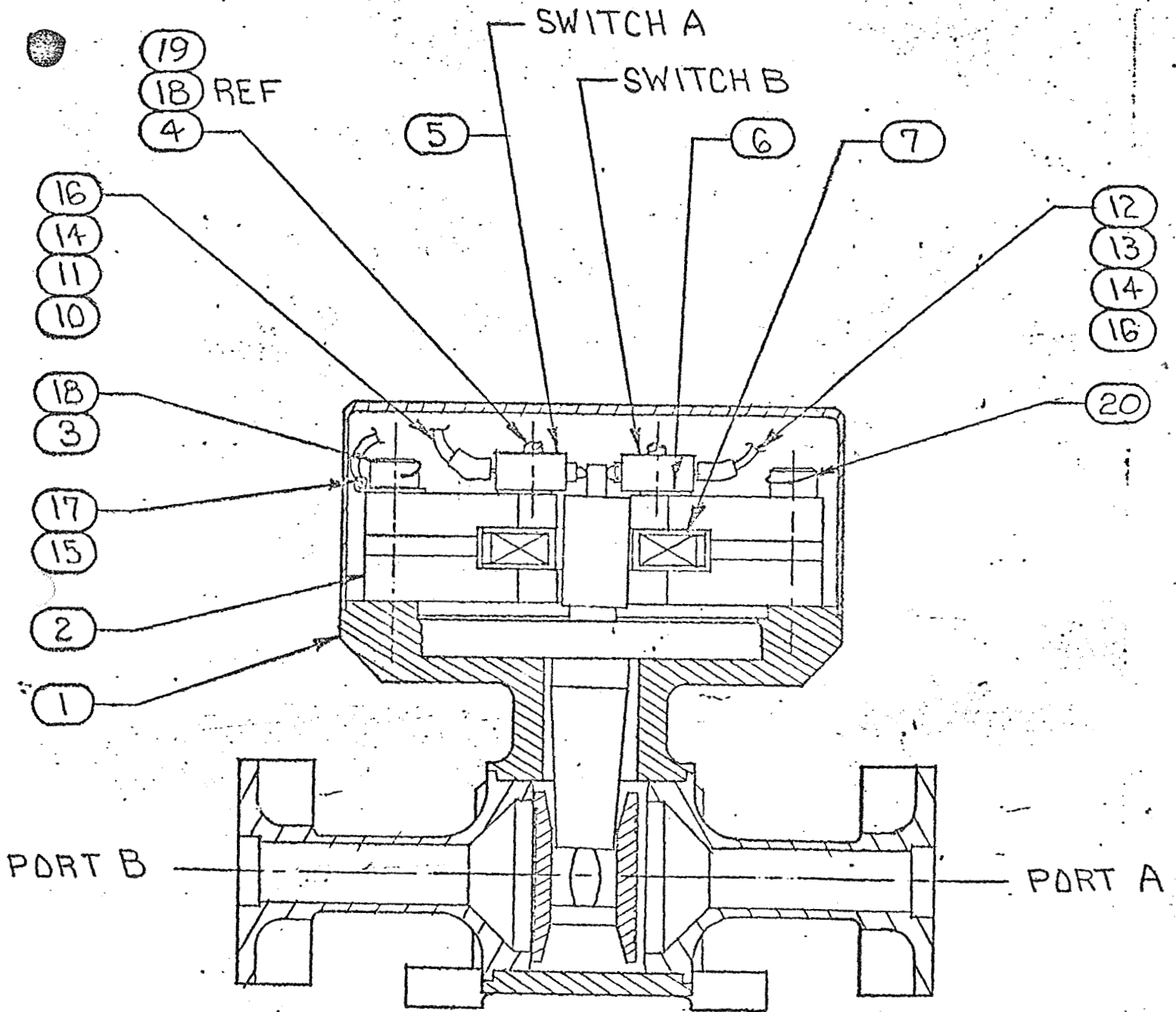

NOTE: Parts List Next Page

Pulse Operated Flow Diverter Valve  
 Assembly Drawing  
 Specification 20M42517

	DESCRIPTION OR TITLE
1	WELDED VALVE ASSY
2	POLE ASSY
3	SCREW, CAP
4	SCREW
5	SWITCH
6	SPACER
7	COIL ASSY
8	COVER
9	RECEPTACLE
10	LEADWIRE GRAY
11	LEADWIRE, ORANGE
12	LEADWIRE, BLUE
13	LEADWIRE, YELLOW
14	LEADWIRE, BROWN
15	LEADWIRE, BLACK
16	TUBING, SHRINK
17	TERMINAL, RING
18	EPOXYLITE
19	LOCKWIRE
20	LOCKWIRE

Pulse Operated Flow Diverter Valve  
Parts List



N71-21199

Two microswitches mounted above the permanent magnets are connected to an electrical indicator system which provides crewmembers with an indication of valve position. The switches are activated by an extension of the armature. When one of the valve ports opens, the affected microswitch closes to provide circuit continuity through the switch.

The microswitches are Honeywell 1HM25 single pole double throw hermetically sealed switches. The switch terminals are brought out to an ITT Cannon connector, P/N PV3A14B12SNS. The same connector also leads to the coil windings.

The valve operates with an 80% methanol 20% water medium at pressures from 0 to 50 psig. Proof and burst pressures are 75 and 125 psig respectively. Overall weight of the valve is approximately 5.5 pounds and its maximum dimensions are 4.6 x 5.2 x 4.1 inches. The valve body and all wetted components, including the valve poppet and seat, are constructed of 316L.

## 5.0 Procedure

### 5.1 Pre-Test Examination (Ref. Spec. 20M42517, Para. 3.4)

The items to be tested shall be visually inspected to verify conformance to NASA/MSFC drawing No. 20M42522 and to Hydraulic Research and Mfg. drawing No. 39000750.

#### 5.1.1 Identification (Ref. Spec. 20M42517, Para. 3.4.5)

Examine each valve assembly for identification markings in accordance with Standard MIL-STD-130.

#### 5.1.2 Workmanship (Ref. Spec. 20M42517, Para. 3.5.12)

Examine each valve assembly to verify that it is fabricated and finished in such a manner that the criteria of appearance, fit, and adherence to specific tolerances have been observed. Particular attention shall be given to the neatness and thoroughness of marking, plating, machine-screw assemblage, and freedom of parts from burrs and sharp edges.

#### 5.1.3 Cleaning (Ref. Spec. 20M42517, Para. 3.5.1)

Each valve shall be cleaned to the requirements of the Contamination Control Plan, QATP-SD-199.

## 5.2 Test Summary

The test samples will be subjected to the following tests.

<u>Test</u>	<u>Sample No.</u>	
	1	2
Functional Tests - 4.3.5	X	X
Acoustic Noise - 4.3.4.11	X	X
Vibration - 4.3.4.9	X	X
Transient Pulses - 4.3.4.12	X	X
Life Cycling - 4.3.4.10	X	X
Temperature - 4.3.4.6	X	X
Full Flow - 4.3.4.5	X	X
Humidity - 4.3.4.1		X
Salt Fog - 4.3.4.2		X
Sand and Dust - 4.3.4.3		X
Fungus - 4.3.4.4		X
Collapse - 4.3.4.13		X
Burst - 4.3.4.14		X
Temperature Cycling - 4.3.4.7	X	
Compatibility - 4.3.4.8	X	

NOTE: Numbers refer to paragraphs in Specification 20M42517.

## 5.3 Functional Test

The following test shall be performed on each qualification test sample before the valve is subjected to the environmental tests.

### 5.3.1 Proof Pressure (Ref. Spec. 20M42517, Para. 4.3.3.1)

The proof pressure test shall be performed in a test setup as shown schematically in Figure 1 and shall be repeated several times after individual environmental tests as specified herein. The valve, port blocking plates, port adapters, "O"-Rings, tubing, and associated test hardware shall be cleaned in accordance with the approved valve cleaning procedure (QATP-SD-199) before the test. Ports A and B of the valve shall be covered with blocking plates sealed by "O"-Rings, and port C of the valve connected to the pressurizing circuit. The valve shall be pressurized with 100% helium to 75 psig and held for 5 minutes minimum. While pressurized, the valve shall be cycled twice to insure that full pressure is applied to all wetted portions of the valve. After the proof pressure test, the unit shall be visually examined for failure, distortion or permanent set.

5.3.2 Leakage, External (Ref. Spec. 20M42517, para. 4.3.3.3.1)

The valve shall be maintained in the setup shown in Figure 1. The Mass Spectrometer shall be calibrated using a leak standard, and background leaks eliminated from the apparatus. Port C of the valve shall be pressurized to 50 psig. The line upstream of the shut-off valve shall be disconnected after closing the shut-off valve. The valve shall be placed in a bell jar and the jar evacuated to 50 microns of mercury or less while the external leakage measurement is made. The leak rate shall be recorded only when the leakage approaches a stabilized reading. The maximum allowable leak rate is  $1 \times 10^{-7}$  STD cc He/Sec.

5.3.3 Leakage, Internal (Ref. Spec. 20M42517, para. 4.3.3.3.2)

This test shall be performed with a setup as shown schematically in Figure 2. The valve shall be energized to close Port A and closure verified by indicator lights on the test panel. Port A shall be pressurized to 5.0, 10.0 and 20.0 psig with the liquid service media, and the leakage measured at each pressure. The process shall be repeated with Port B closed, and pressurized. The leakage measurements shall be made 3 times on each port. The allowable leak rate shall not exceed 0.20 STD cc Sec, liquid service media.

5.3.4 Acceptance Vibration (Ref. Spec. 20M42517, para. 4.3.5(c))

The valve shall be mounted to a flat plate, utilizing the three mounting feet provided. Ports A and B shall be covered with the blocking plates, and Port C pressurized to 20 psig pneumatically. The valve shall be cycled twice to insure equal pressure distribution throughout the wetted portion of the valve. Pressure within the valve shall be monitored by means of a pressure gage. The test setup shall be as shown in Figure 3 with the exception of the output accelerometers.

The test samples shall be subjected to random vibration along the axis normal to the mounting plane to the levels listed below. An X-Y plot of spectral density versus frequency shall be provided with each run.

<u>Frequency (Hz)</u>	<u>Power Spectral Density</u>
20-46	+6.0 DB per octave
46-100	0.0357 g <sup>2</sup> per Hz
100-210	-9.0 DB per octave
210-750	0.00375 g <sup>2</sup> per Hz
750-1155	-12.0 DB per octave
1155-2000	0.000655 g <sup>2</sup> per Hz

5.3.5 Vacuum, Internal (Ref. Spec. 20M42517, Para. 4.3.3.2)

Ports A and B of the valve shall be capped with blocking plates and port C connected to a vacuum source as shown in Figure 4. The assembly shall be evacuated to  $1.94 \times 10^{-4}$  torr (while external pressure remains atmospheric) and the vacuum maintained for a period of five (5) minutes minimum. When the specified vacuum is achieved, the valve shall be cycled twice to insure equal pressure distribution throughout the wetted portion of the valve. The valve shall then be visually inspected for damage, deformation or permanent set.

5.3.6 Proof Pressure

The test described in paragraph 5.3.1 shall be performed with exception of the cleaning procedure which shall not be repeated.

5.3.7 Leakage External (Gaseous)

The leakage test described in paragraph 5.3.2 shall be performed.

5.3.8 Leakage Internal

The test described in paragraph 5.3.3 shall be performed.

5.3.9 Circuit Resistance (Ref. Spec. 20M42517, Para. 4.3.3.4)

5.3.9.1 Port A of the valve shall be placed in the open position by applying 28 volts d. c. to pins L(+) and J(-). The resistance between the pins listed on the data sheets under "Port A Open" paragraph 5.3.9.1 shall be measured.

5.3.9.2 Resistance measurements shall then be made with port B of the valve open (28 volts applied across M(+) and K(-)) between the pins listed on the data sheets under "Port B Open," paragraph 5.3.9.2.

All of the resistance measurements specified above shall be performed three (3) times.

5.3.10 Insulation Resistance (Ref. Spec. 20M42517, Para. 4.3.3.5)

5.3.10.1 Insulation resistance measurements shall be made with an applied voltage of 500 volts d. c. between the pins listed on the data sheets under paragraph 5.3.10.1.

5.3.10.2 Port A of the valve shall be opened by energizing pins L(+) and J(-) with 28 volts d. c. and insulation resistance measurements made with 500 volts d. c. applied between the pins listed in paragraph 5.3.10.2 of the data section.

5.3.10.3 Connector pins M(+) and K(-) shall be energized with 28 volts d. c. to open port B, and insulation resistance measurements made between the pins listed in paragraph 5.3.10.3 of the data section.

Insulation resistance measurements shall be recorded only if the value is stable or increasing.

5.3.11 Minimum Operating Voltage, Unpressurized Assembly  
(Ref. Spec. 20M42517, Para. 4.3.3.7)

This test shall be conducted with a pulse generator oscilloscope and test panel connected as shown in Figure 5. The pulse generator shall be set for a 100 millisecond pulse width. The minimum operating voltage shall be measured by slowly increasing the power supply voltage from zero until the valve actuates, as indicated by the indicator lights on the test panel. Photographs of the oscillographic traces are to be taken.

The procedure is to be repeated for port B by applying pulses to pins M(+) and K(-) and monitoring switch closure. These voltage measurements shall be performed at least three (3) times for each port. The minimum operating voltage is not to exceed 18 volts d. c.

5.3.12 Minimum Operating Voltage, Pressurized Assembly  
(Ref. Spec. 20M42517, Para. 4.3.3.7)

The valve shall be pressurized to 50 psig with 100% helium as shown on the pneumatic schematic of Figure 5. The minimum operating voltage test described in paragraph 5.3.11 shall be performed.

5.3.13 Minimum Pulse Duration, Pressurized Assembly  
(Ref. Spec. 20M42517, Para. 4.3.3.8)

The valve assembly shall be maintained in the test setup shown in Figure 5, and the valve pressurized to 50 psig. The power supply shall be adjusted to 28 volts d. c., and the pulse generator set to its minimum pulsed width. The minimum operating pulse width for the valve shall be measured by slowly increasing the generator pulse width until the valve actuates as evidenced by switch closure. Photographs of the oscilloscope trace shall be taken, and the pulse duration recorded. The minimum pulse duration shall be measured at least three (3) times for each port. The maximum allowable operating pulse is 100 milliseconds.

5.3.14 Minimum Pulse Duration, Unpressurized Assembly  
(Ref. Spec. 20M42517, Para. 4.3.3.8)

The valve assembly shall be left in the setup shown in Figure 5, and the test outlined in paragraph 5.3.13 repeated with the valve unpressurized. Tolerance-100 milliseconds maximum.

5.3.15 Power Consumption (Ref. Spec. 20M42517, Para. 4.3.3.9)

With the valve setup as shown in Figure 6 and with the power supply set at 28 volts, the current shall be measured and the power computed. Power measurements shall be made for each coil. The maximum allowable power consumption is 31.5watts. Current shall be measured immediately after applying power, since current will decrease when coil warms up.

5.4 Acoustic Noise (Ref. Spec. 20M42517, Para. 4.3.4.11)

The two qualification units shall be mounted on a plate and pressurized with the liquid service media by means of a gas bottle. The assembly shall be mounted in a reverberation chamber of sufficient dimensions to generate the sound pressure specified in Appendix E of specification 50M02408B. The sound pressure field levels shall be checked with the specimens mounted in the test chamber. Trial runs shall be made in accordance with paragraph 5.2.5.2.2 of specification 50M02408 until the lower limits of the acoustic spectrum have been exceeded. The upper level of the spectrum may be exceeded because of equipment limitations.

Two full level runs shall then be made. The first shall be with the dual port axis mounted parallel to the sound propagation direction and the second, mounted with the axis of the valve mounted parallel to the direction of sound propagation. The acoustic noise test will be performed under subcontract by Noise Unlimited of Sommerville, New Jersey.

Following the test, the valve shall be visually examined for damage and the following tests performed:

Proof Pressure	Para. 5.3.1
Vacuum	Para. 5.3.5
Leakage	Paras. 5.3.2, 5.3.3
Circuit Resistance	Para. 5.3.9
Insulation Resistance	Para. 5.3.10
Position Indicators	Para. 5.3.9
Minimum Operating Voltage	Paras. 5.3.11, 5.3.12
Pulse Duration	Paras. 5.3.13, 5.3.14
Power	Para. 5.3.15

## 5.5 Vibration (Ref. Spec. 20M42517, Para. 4.3.4.9)

Both qualification valves shall be bolted to a flat plate through the valve mounting holes. The valves shall be filled with the liquid service media and pressurized to 20 psig as shown schematically in Figure 3. The primary port shall be opened and the continuity monitored between connector pins A and E during the test.

A control accelerometer and three output accelerometers shall be used for sinusoidal vibration evaluation. The output accelerometers shall be mounted to sense acceleration along each of the three major axes of the valve. The output signals from the accelerometers shall be displayed on an oscillograph.

### 5.5.1 Sinusoidal Excitation, Vehicle Dynamics

The test units shall be subjected to the sinusoidal excitation schedule listed below at a scan rate of 3 octaves per minute along each of three mutually perpendicular axes. One of the axis shall coincide with the dual port axis.

#### Vehicle Dynamics Criteria (Port C Axis) (3-40 HZ @ 3 oct. /min.)

<u>Frequency</u>	<u>Level</u>
3-7	0.59 D. A.
7-10	1.6g Peak
10-40	0.5g Peak

#### Lateral Axes (2-20 HZ @ 3 oct. /min.)

<u>Frequency</u>	<u>Level</u>
2-4	0.48 D. A.
4-10	0.4 g's Peak
10-20	0.12 g's Peak

### 5.5.2 Sine Evaluation Criteria

The two test valves shall be subjected to the following sinusoidal scan at 1.0 octave per minute along each of three major axes.

<u>Frequency (Hz)</u>	<u>Level</u>
20-100	0.0020
100-2000	1.0 Peak (g)

### 5.5.3 Random Criteria, High Level

The valves shall be subjected to the random excitation levels shown below for a period of one (1) minute per axis. The valve shall be vibrated along each of the major axes.

#### High Level Longitudinal and Lateral Axes

<u>Frequency (Hz)</u>	<u>Level</u>
20	0.027 g <sup>2</sup> /Hz.
20-46	Inc. at 6.0 DB/Octave
46-100	0.14 g <sup>2</sup> /Hz
100-210	Dec. at 9.0 DB/Octave
210-750	0.015 g <sup>2</sup> /Hz
750-1155	Dec. 12 DB/Octave
1155-2000	0.0026 g <sup>2</sup> /Hz
	Composite = 5.5 grms.

### 5.5.4 Random Criteria, Low Level

The valves shall be subjected to the low level random vibration levels shown below for four (4) minutes along each of the 3 major axes.

#### Low Level Longitudinal and Lateral Axes

<u>Frequency (Hz)</u>	<u>Level</u>
20	0.012 g <sup>2</sup> /Hz.
20-46	Inc. at 6.0 DB/Octave
46-100	0.064 g <sup>2</sup> /Hz
100-210	Dec. at 9.0 DB/Octave
210-750	0.0067 g <sup>2</sup> /Hz
750-1155	Dec. at 12.0 DB/Octave
1155-2000	0.00124 g <sup>2</sup> /Hz
	Composite = 3.6 grms.



At the conclusion of all the vibration runs, the valves shall be visually examined for failure, and the following tests performed:

Proof Pressure	Para. 5.3.1
Vacuum	Para. 5.3.5
Leakage	Paras. 5.3.2, 5.3.3,
Circuit Resistance	Para. 5.3.9
Insulation Resistance	Para. 5.3.10
Position Indicators	Para. 5.3.9
Minimum Operating Voltage	Paras. 5.3.11, 5.3.12
Pulse Duration	Paras. 5.3.13, 5.3.14
Power	Para. 5.3.15

5.6 Transient Pulses (Ref. Spec. 20M42517, Para. 4.3.4.12)

This test is performed in five parts to measure the ability of the valve to withstand spurious transients as defined in Figure 3 of specification 20M42517.

5.6.1 Minimum Operating Voltage (Unpressurized)  
(Ref. Spec. 20M42517, Para. 4.3.3.7)

The test outlined in paragraph 5.3.11 shall be performed.

5.6.2 Minimum Operating Voltage (Pressurized)  
(Ref. Spec. 20M42517, Para. 4.3.3.7)

The test outlined in paragraph 5.3.12 shall be performed.

5.6.3 Minimum Pulse Duration (Pressurized)  
(Ref. Spec. 20M42517, Para. 4.3.3.8)

The test outlined in paragraph 5.3.13 shall be performed.

5.6.4 Minimum Pulse Duration (Unpressurized)  
(Ref. Spec. 20M42517, Para. 4.3.3.8)

The test outlined in paragraph 5.3.14 shall be performed.

5.6.5 Transient Pulses

The valve shall be setup in a test circuit as shown in Figure 8. Transient pulses shall be applied to one coil (B as shown in Figure 8) and a steady state signal applied to the opposite coil as shown in the table below. The valve shall be pressurized to 50 psig. Oscilloscope photographs of the signal on both coils shall be taken simultaneously. Reference photographs shall be made before the transient test of the standard

28 volt signal on each coil. After the transient signals have been applied to one coil the circuits shall be switched and the procedure repeated for the second coil. Application of the transient signal shall not cause the valve to actuate or switch from one position to the other.

<u>Coil A</u>		<u>Coil B</u>	
<u>Amplitude</u> (Volts)	<u>Duration</u> (Millisecs.)	<u>Amplitude</u> (Volts)	<u>Duration</u> (Millisecs.)
+28	Steady-State	+72	.005
+28	Steady-State	0	0
+28	Steady-State	-19	9
+72	.005	+28	Steady-State
0	0	+28	Steady-State
-19	9	+28	Steady-State

#### 5.6.6 Coil Transient Voltage (No Spec. para. )

With the valve at room temperature, a 28 volt d.c. signal shall be applied to each active coil individually so as to actuate the valve. Before the coil has been energized for 10 seconds, the valve shall be de-energized and the coil transient measured with an oscilloscope using the circuit shown in Figure 7. An oscilloscope photograph of the closing voltage transient shall be made for each coil. The maximum allowable peak transient voltage shall not exceed 150 percent of the rated coil voltage. The transient voltage shall be measured a minimum of three (3) times on each active coil, and the largest transient value recorded as the actual value.

#### 5.7 Life Cycling (Ref. Spec. 20M42517, Para. 4.3.4.10)

A minimum of 1000 cycles shall be applied to each valve by means of the test circuit shown in Figure 9. One cycle is defined as moving from the primary to the secondary position, and back to the primary position or vice versa. The cycling shall be performed with the valve filled with the liquid service media, 28 volts d.c. applied to the valve coils, and with the microswitches resistively loaded to 3 amperes at 28 volts d.c. The number of cycles shall be monitored by means of a pulse counter. Each cycle shall be approximately 5 seconds in duration.

After 150, 300, 500 and 750 cycles, the following tests shall be performed:

Leakage	Para. 5.3.3
Circuit Resistance	Para. 5.3.9
Position Indicators	Para. 5.3.9
Minimum Operating Voltage	Paras. 5.3.11, 5.3.12
Pulse Duration	Paras. 5.3.13, 5.3.14
Power	Para. 5.3.15

At the completion of the test, the valves shall be subjected to the following tests:

Proof Pressure	Para. 5.3.1
Vacuum	Para. 5.3.5
Leakage	Paras. 5.3.2, 5.3.3
Circuit Resistance	Para. 5.3.9
Insulation Resistance	Para. 5.3.10
Position Indicators	Para. 5.3.9

Minimum Voltage  
Pulse Duration  
Power

Paras. 5.3.11, 5.3.12  
Paras. 5.3.13, 5.3.14  
Para. 5.3.15

## 5.8 High and Low Temperature

### 5.8.1 High Temperature, Gaseous (Ref. Spec. 20M42517, Para. 4.3.4.6.1 (a))

The two valves shall be placed unfilled in a chamber and setup as shown in Figure 10. The temperature shall be raised to +165°F and the valves allowed to stabilize at this temperature. After stabilization, one coil shall be energized with 30 volts d.c. for 5 continuous minutes. During this period, the coil resistance shall be monitored by measuring the current drain. Thermocouples shall be bonded to the valve to monitor valve temperature. At the end of the 5 minute period, the valve shall be de-energized and the valve body allowed to return to +165°F. This cycle shall be performed 10 times, on each coil. The valve shall be operated between each temperature cycle. At the completion of the cycling the valve shall be allowed to stabilize at 100°F and the following tests performed:

Leakage	Para. 5.3.3
Circuit Resistance	Para. 5.3.9
Insulation Resistance	Para. 5.3.10
Position Indicators	Para. 5.3.9
Minimum Voltage	Paras. 5.3.11, 5.3.12
Pulse Duration	Paras. 5.3.13, 5.3.14
Power	Para. 5.3.15

### 5.8.2 Low Temperature, Gaseous

The two test valves shall be placed, unfilled, in a chamber and setup as shown in Figure 16 and the temperature lowered to -65°F. The valve temperature shall be allowed to stabilize at -65°F and held for a minimum of 48 hours. Thermocouples shall be bonded to the valve to indicate valve temperature. While stabilized at -65°F, the following tests shall be performed:

Leakage	Paras. 5.3.2, 5.3.3
Circuit Resistance	Para. 5.3.9
Insulation Resistance	Para. 5.3.10
Position Indicators	Para. 5.3.9
Minimum Operating Voltage	Paras. 5.3.11, 5.3.12
Pulse Duration	Paras. 5.3.13, 5.3.14
Power	Para. 5.3.15

5.8.3 After High and Low Temperature Gaseous

At the completion of gaseous temperature testing, the valve shall be returned to room temperature, visually examined for failure and tested to the requirements listed below:

Leakage	Paras. 5.3.2, 5.3.3
Circuit Resistance	Para. 5.3.9
Insulation Resistance	Para. 5.3.10
Position Indicators	Para. 5.3.9
Minimum Operating Voltage	Paras. 5.3.11, 5.3.12
Pulse Duration	Paras. 5.3.13, 5.3.14
Power	Para. 5.3.15

5.8.4 High Temperature, Liquid (Ref. Spec. 20M42517, Para. 4.3.4.6.2)

The two qualification valves shall be setup as in Figure 10 and filled with the liquid service media. The chamber temperature shall be increased and the valve allowed to stabilize at +100°F. After stabilizing as indicated on the recorder trace, the following tests shall be performed:

Leakage	Para. 5.3.3
Circuit Resistance	Para. 5.3.9
Insulation Resistance	Para. 5.3.10
Position Indicators	Para. 5.3.9
Minimum Voltage	Para. 5.3.11, 5.3.12
Pulse Duration	Para. 5.3.13, 5.3.14
Power	Para. 5.3.15

5.8.5 Low Temperature, Liquid

The valve shall be returned to the setup shown in Figure 16, filled with liquid service media and the tests of paragraph 5.8.4 repeated, except that the temperature shall be -65°F.

5.8.6 After High and Low Temperature Liquid

At the completion of the liquid temperature testing, the valve shall be returned to room temperature, visually examined for failure and tested to the requirements listed below:

Leakage	Para. 5.3.2, 5.3.3,
Circuit Resistance	Para. 5.3.9
Insulation Resistance	Para. 5.3.10
Position Indicators	Para. 5.3.9
Minimum Operating Voltage	Paras. 5.3.11, 5.3.12
Pulse Duration	Paras. 5.3.13, 5.3.14
Power	Para. 5.3.15

5.9 Full Flow (Ref. Spec. 20M42517, Para. 4.3.4.5)

The valve shall be connected to a positive pressure pump as shown in Figure 11. The pump flow rate shall be adjusted to 900 lb/hr (2.12 GPM) and the flow rate measured with a flow meter. The pressure drop across the valve shall be measured as the reading on the A P pressure gage. While the valve is passing full flow, the following tests will be performed:

Pressure drop, from Ports A to C, B to C,  
C to A and C to B.

Position Indicators	Para. 5.3.9
Minimum Voltage	Paras. 5.3.11, <del>5.3.12</del>
Pulse Duration	Paras. <del>5.3.13</del> , 5.3.14
Power	Para. 5.3.15

5.10 Humidity(Ref. Spec. 20M42517, Para. 4.3.4.1)

The valve shall be placed in a chamber conforming to the requirements of MIL-STD-810A. The temperature and relative humidity in the chamber shall be controlled as shown in Figure 15 over a period of 24 hours. The cycle shall be repeated 10 times for a minimum test period of 240 hours. At the conclusion of the humidity test, the following tests will be performed:

Leakage	Paras. 5.3.2, 5.3.3,
Circuit Resistance	Para. 5.3.9
Insulation Resistance	Para. 5.3.10
Position Indicators	Para. 5.3.9
Minimum Voltage	Paras. 5.3.11, 5.3.12
Pulse Duration	Paras. 5.3.13, 5.3.14
Power	Para. 5.3.15

5.11 Salt Fog (Ref. Spec. 20M42517, Para. 4.3.4.2)

One test valve shall be placed in a chamber and exposed to the salt fog atmosphere for a minimum of 48 hours in accordance with method 509.1 of MIL-STD-810A. At the end of the test period, the valve shall be wiped free of salt deposits, examined for failure, and the following tests performed:

Leakage	Paras. 5.3.2, 5.3.3
Circuit Resistance	Para. 5.3.9
Insulation Resistance	Para. 5.3.10
Position Indication	Para. 5.3.9
Minimum Voltage	Paras. 5.3.11, 5.3.12
Pulse Duration	Paras. 5.3.13, 5.3.14
Power	Para. 5.3.15

5.12 Sand and Dust (Ref. Spec. 20M42517, Para. 4.3.4.3)

A qualification unit shall be placed in a chamber, and a sand and dust composition conforming to MIL-STD-810A method 510.1 circulated throughout the chamber. The chamber will be maintained at 77°F for a period of 2 hours, and the air velocity through the test chamber at 100 to 500 feet per minute. After the 2 hour period, the temperature shall be raised and maintained at 160°F for 2 hours. At the end of the period, the valve shall be wiped free of dust, inspected for damage, and the following tests performed:

Leakage	Paras. 5.3.2, 5.3.3
Circuit Resistance	Para. 5.3.9
Insulation Resistance	Para. 5.3.10
Position Indicators	Para. 5.3.9
Minimum Voltage	Paras. 5.3.11, 5.3.12
Pulse Duration	Paras. 5.3.13, 5.3.14
Power	Para. 5.3.15

5.13 Fungus (Ref. Spec. 20M42517, Para. 4.3.4.4)

One valve shall be placed in a test chamber. The internal chamber temperature shall be raised to  $86 \pm 3.6^\circ\text{F}$  and  $95 \pm 5$  percent relative humidity, and maintained throughout the test period. A known nutrient material shall be placed near the valve to be used as a reference, and both the valve and the known nutrient material sprayed with fungus spores, prepared in accordance with MIL-STD-810A method 508.1. The test period shall be 28 days minimum. At the end of the period, the test item and the nutrient sample shall be removed from the chamber. The nutrient material shall be examined to verify fungus growth, and the valve shall be visually examined for damage and evidence of fungus growth. At the conclusion of the fungus test, the tests listed below shall be performed:

Leakage	Paras. 5.3.2, 5.3.3
Circuit Resistance	Para. 5.3.9
Insulation Resistance	Para. 5.3.10
Position Indicators	Para. 5.3.9
Minimum Voltage	Paras. 5.3.11, 5.3.12
Pulse Duration	Paras. 5.3.13, 5.3.14
Power	Para. 5.3.15

5.14 Collapse Pressure (Ref. Spec. 20M42517, Para. 4.3.4.13)

The valve shall be placed in a container with two ports blocked, and the third connected to a pressure gauge outside of the container as shown in Figure 12, so that the internal pressure of the valve can be monitored. The container pressure shall then be raised to 19 psig pneumatically and held for 3 minutes minimum before reducing to zero. After the test, the valve shall be visually examined for evidence of yielding cracks or rupture.

5.15 Burst Pressure (Ref. Spec. 20M42517, Para. 4.3.4.14)

NOTE: The burst pressure test shall be the last one performed.

Hydrostatic pressure shall be applied to the common port of the valve with the dual ports blocked as shown in Figure 13. The valve internal pressure shall be slowly increased to 125 psig and held for 3 minutes. The unit shall then be visually examined for evidence of yielding, cracks, rupture and operated for a few cycles to ascertain that the valve is still functioning. The pressure shall be gradually raised again until the assembly ruptures, and the rupture pressure recorded.

5.16 Temperature Cycling (Ref. Spec. 20M42517, Para. 4.3.4.7)

The valve shall be placed in a thermal chamber with the valve filled with the service media, and pressurized to 20 psig by means of a gas bottle. The valve will be placed in a methanol bath with thermocouples bonded to the base, mid-section and cover. A schematic of the test setup is included in Figure 10. The bath temperature will be controlled with liquid nitrogen on demand from an automatic temperature controller.

The upper limit of valve temperature shall be set by heating the bath with a hot plate, and controlling the plate automatically with separate temperature controller. A timer shall sequence the two temperature controllers to provide adequate dwell time at the temperature extremes.

The test sequence shall consist of cycling the valve temperature from +120°F to -0°F and back to +120°F for a total of 200 cycles. At the conclusion of the test, the valve assembly shall be returned to room temperature, examined for failure and subjected to the following tests:

Leakage	Paras. 5.3.2, 5.3.3
Circuit Resistance	Para. 5.3.9
Insulation Resistance	Para. 5.3.10
Position Indicators	Para. 5.3.9
Minimum Voltage	Paras. 5.3.11, 5.3.12
Pulse Duration	Paras. 5.3.13, 5.3.14
Power	Para. 5.3.15

5.17 Compatibility (Ref. Spec. 20M42517, Para. 4.3.4.8)

The valve shall be filled with the liquid service media with the dual ports capped, and the inlet pressurized to 20 psig by means of a gas bottle. The valve and associated plumbing shall be thoroughly cleaned and flushed in accordance with SD-199 (Contamination Control Plan for the Hydraulic Research Latching Valve Assembly HR Dwg. No. 39000750) prior to use. The fluid medium shall be chemically analyzed before the test. The test apparatus shall then be installed in a bell jar as shown in Figure 14, and the bell jar evacuated to  $1.0 \times 10^{-6}$  torr. After 30, 60, 120 and 190 days the valve shall be removed from the bell jar, the fluid visually examined for discoloration or contamination, and chemically analyzed. At these intervals, the tests listed below shall be performed. When the test is resumed, the valve shall be filled with clean fluid.

Leakage	Paras. 5.3.2, 5.3.3
Circuit Resistance	Para. 5.3.9
Insulation Resistance	Para. 5.3.10
Position Indicators	Para. 5.3.9
Minimum Voltage	Paras. 5.3.10, 5.3.11
Pulse Duration	Paras. 5.3.12, 5.3.13
Power	Para. 5.3.15



APPENDIX A

Test Schematics

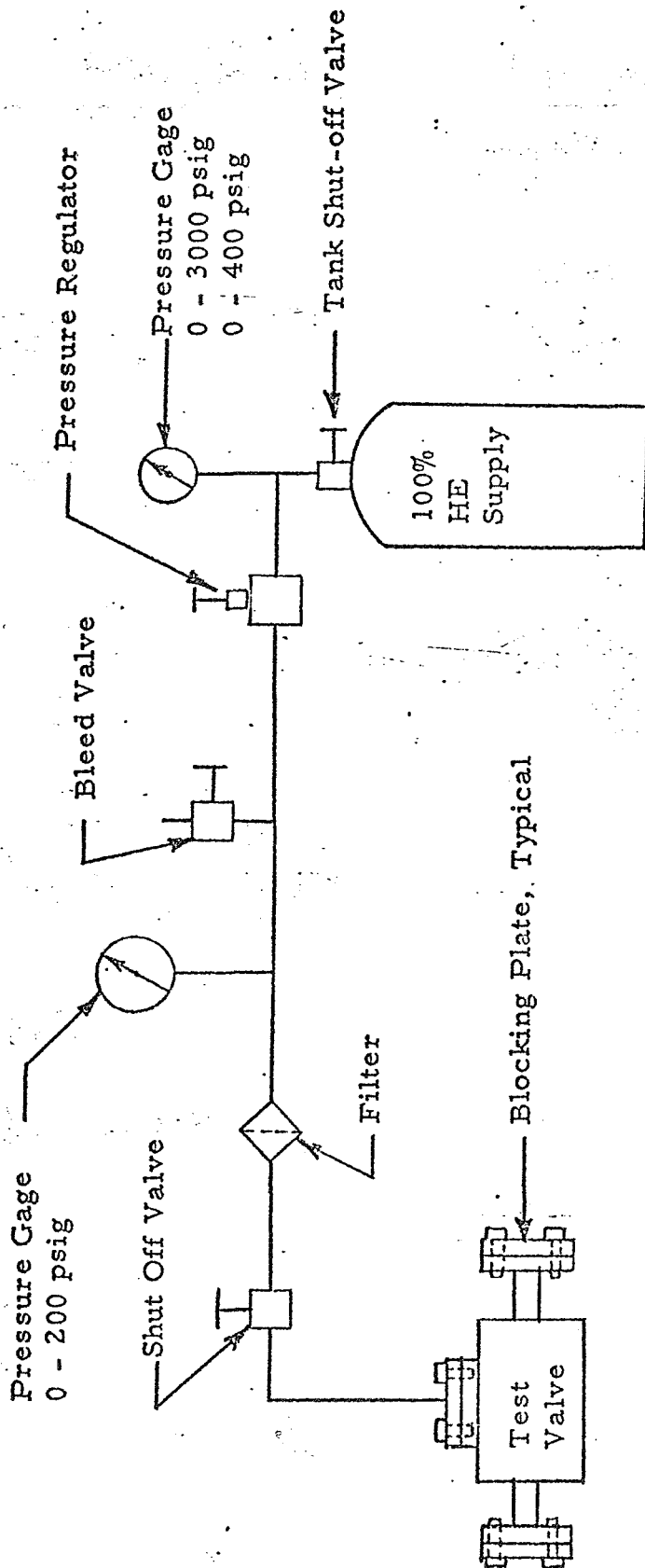

Proof and External Leakage Test  
Flow Diverter Valve Methanol/Water  
Specification 20M42517

Figure 1

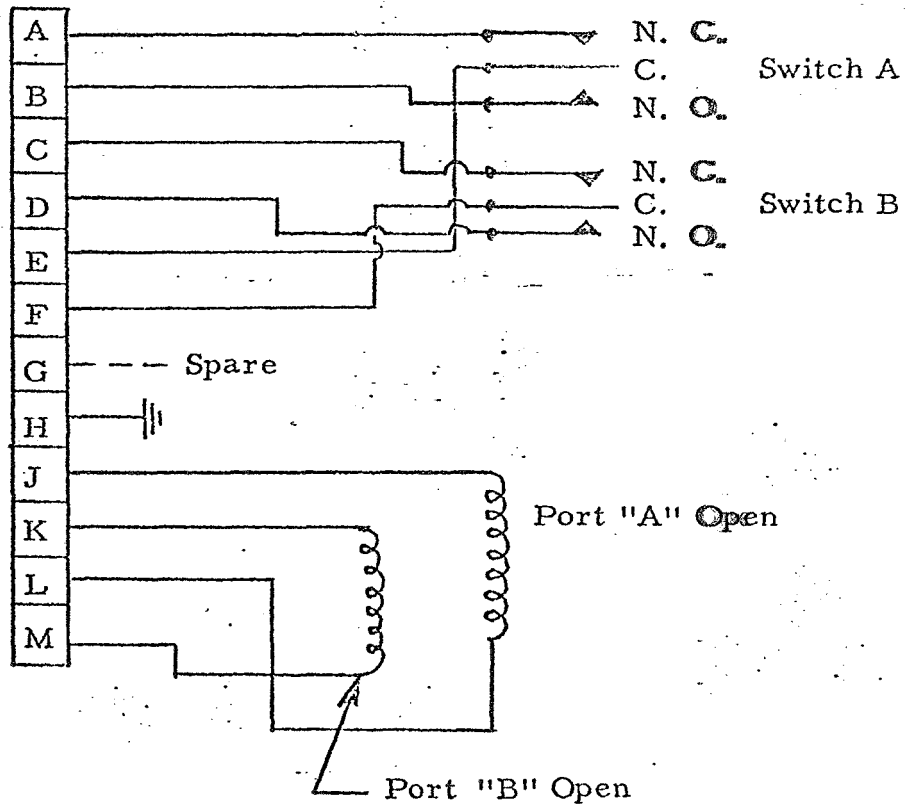
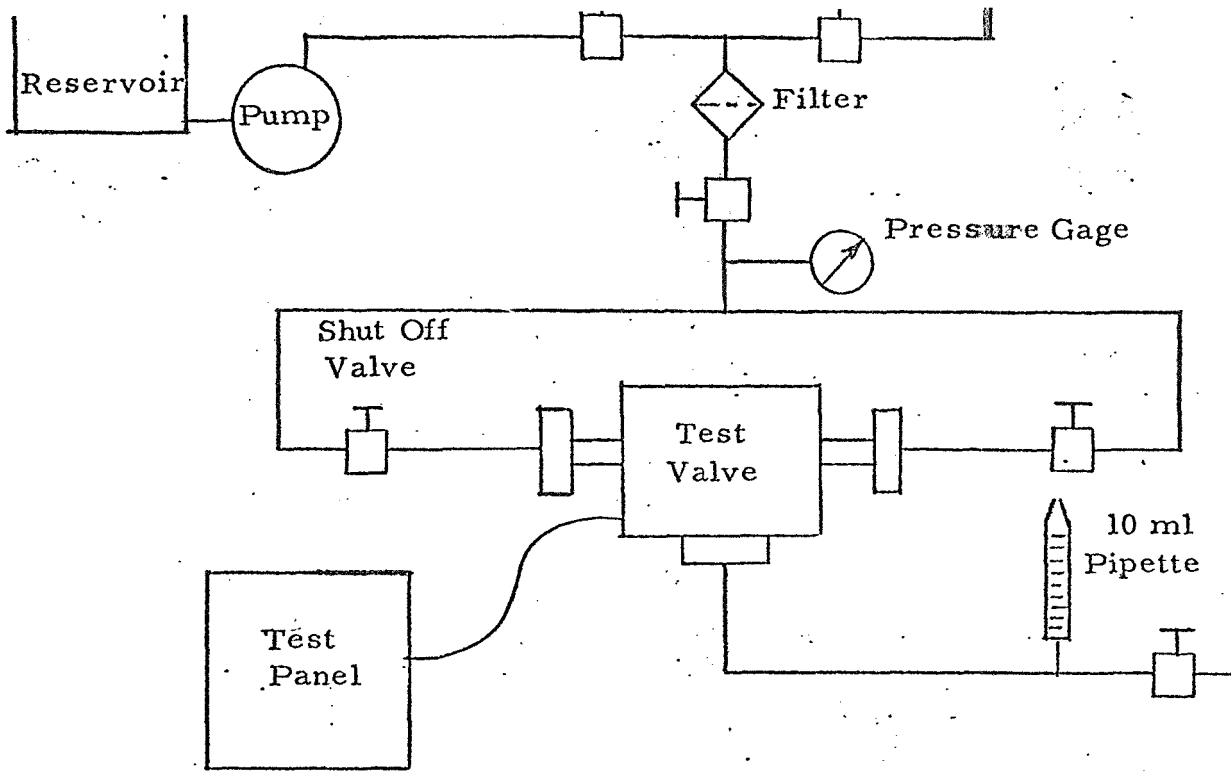

Internal Leakage Test  
 Flow Diverter Valve, Methanol/Water  
 Specification 20M42517

Figure 2.

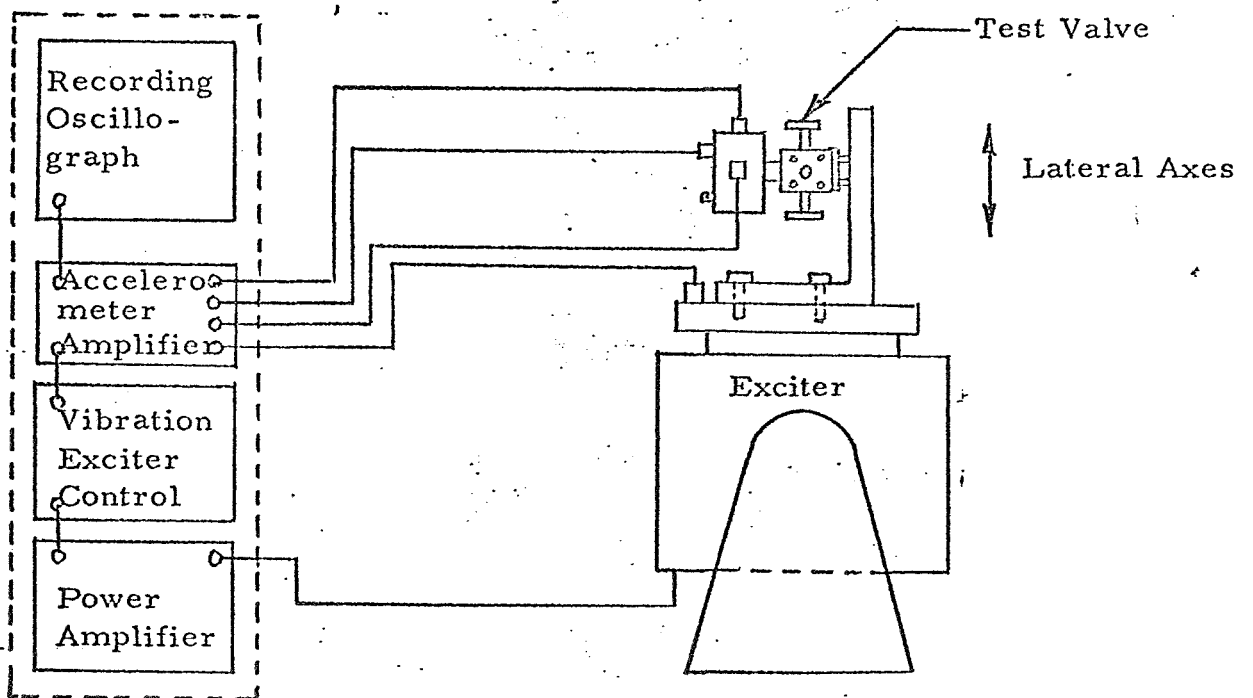
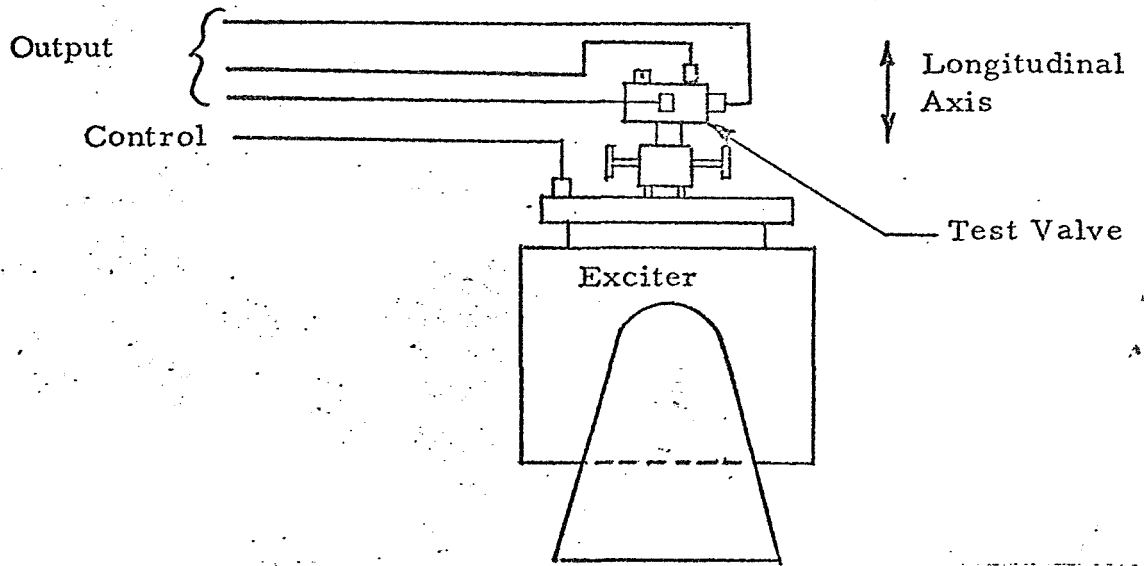
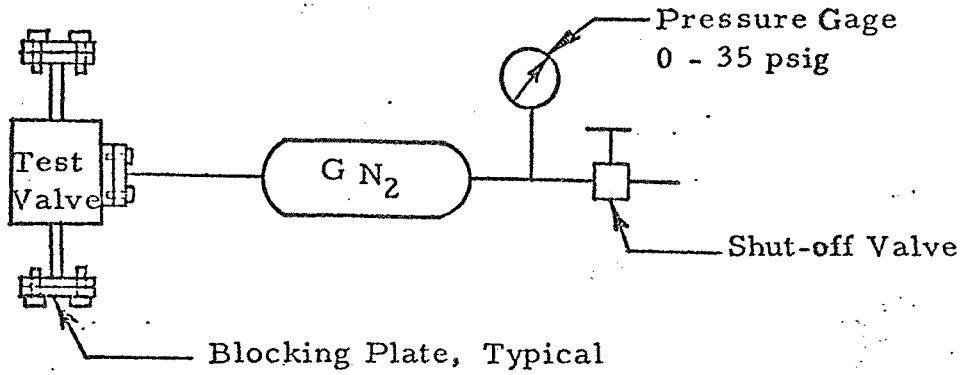

Vibration Test  
Flow Diverter Valve, Methanol/Water  
Specification 20M42517

Figure 3

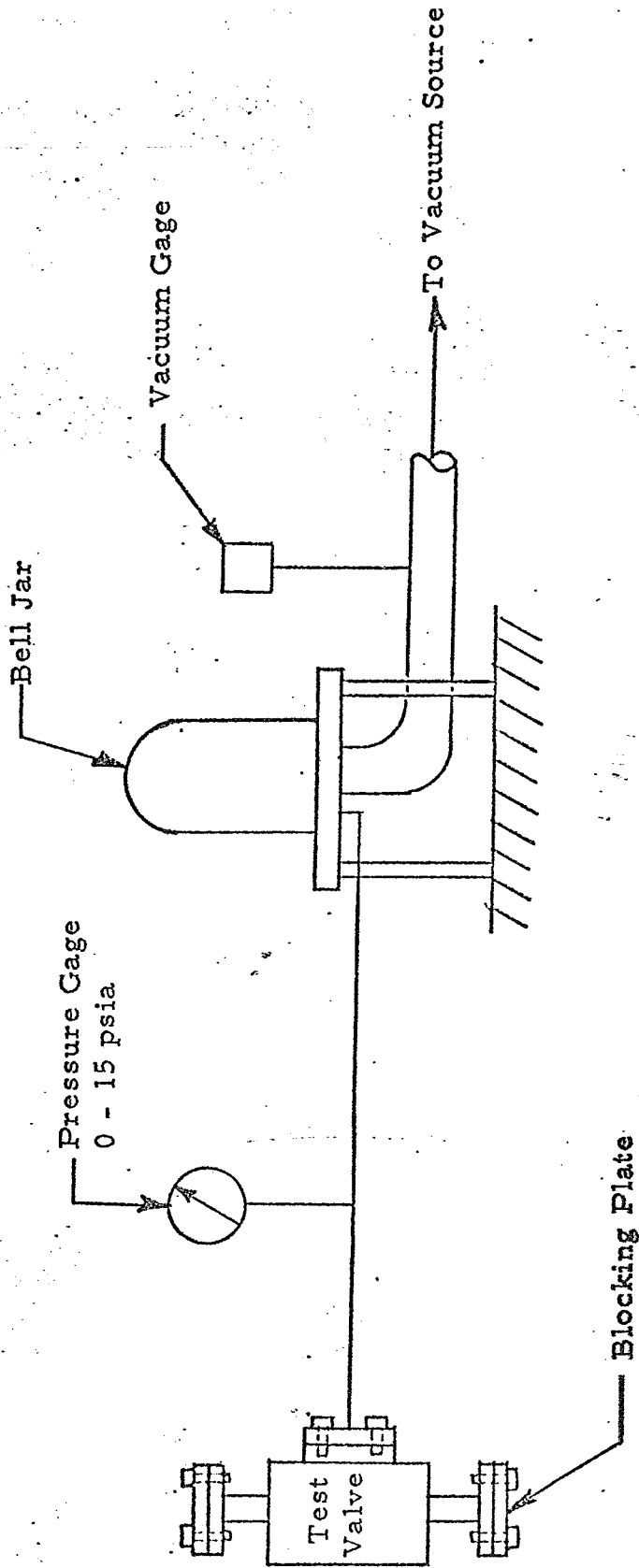

Vacuum Test  
 Flow Diverter Valve, Methanol/Water  
 Specification 20M42517

Figure 4

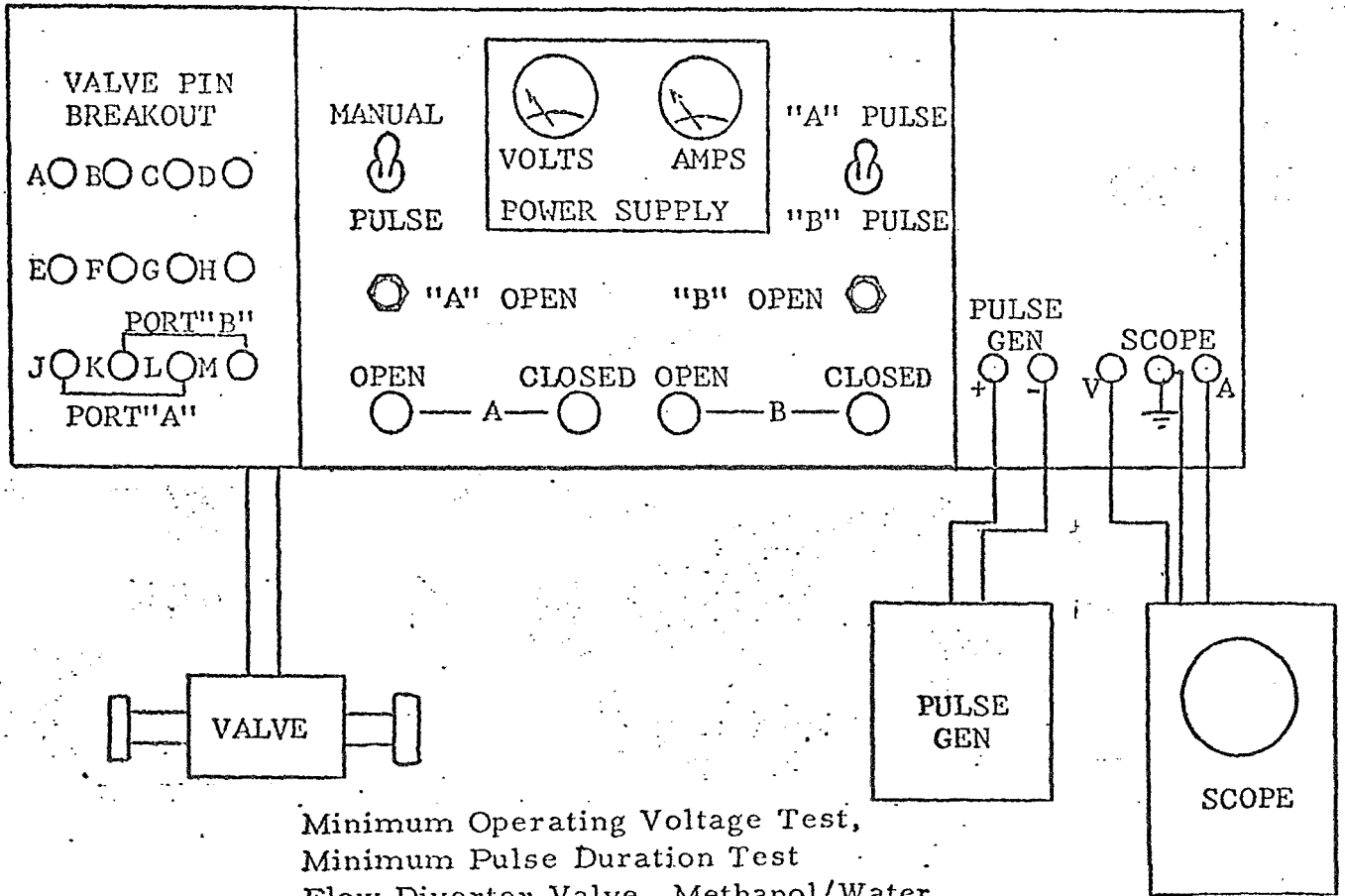
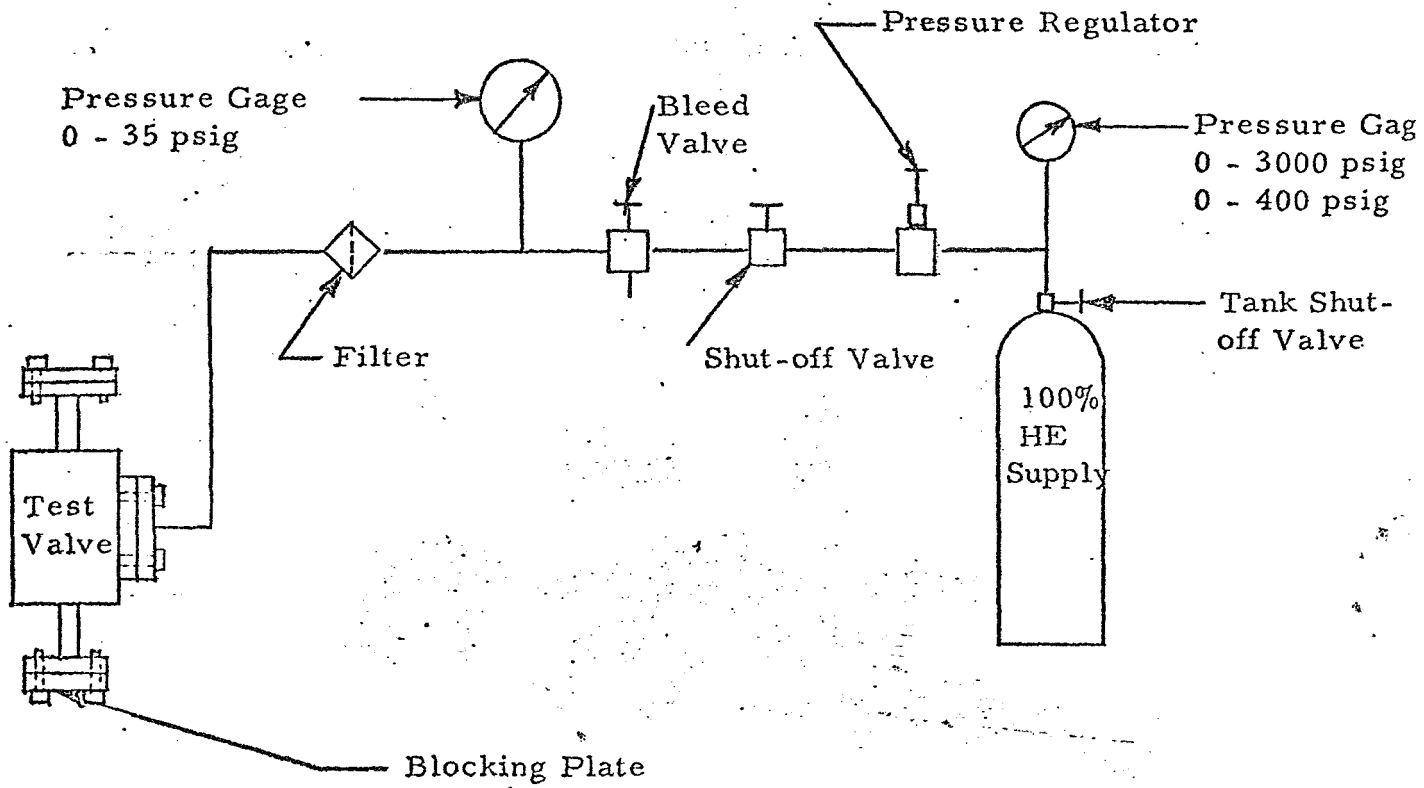

Minimum Operating Voltage Test,  
Minimum Pulse Duration Test  
Flow Diverter Valve, Methanol/Water  
Specification 20M42517

Figure 5

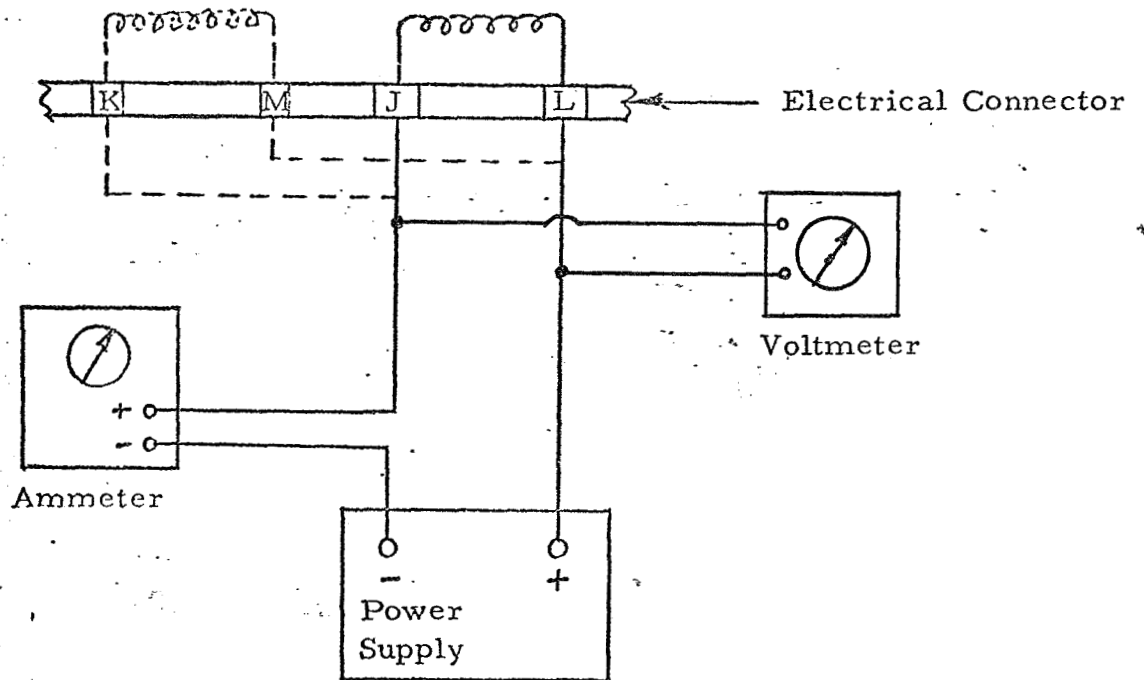

Power Consumption Test  
 Flow Diverter Valve, Methanol/Water  
 Specification 20M42517

Figure 6

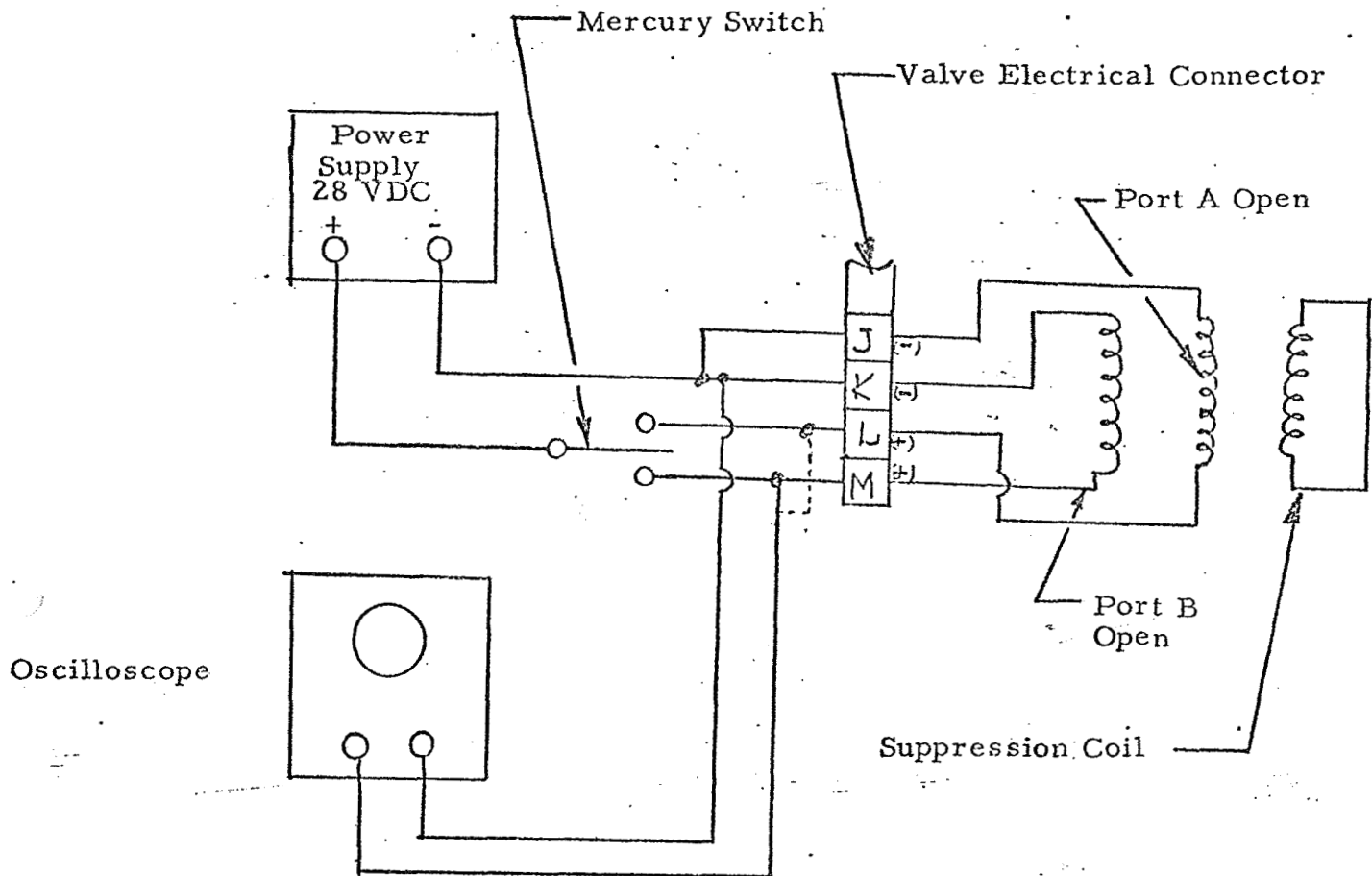

Coil Transient Voltage Test  
 Flow Diverter Valve, Methanol/Water  
 Specification 20M42517

Figure 7.



Pressure Gage  
0 - 200 psig

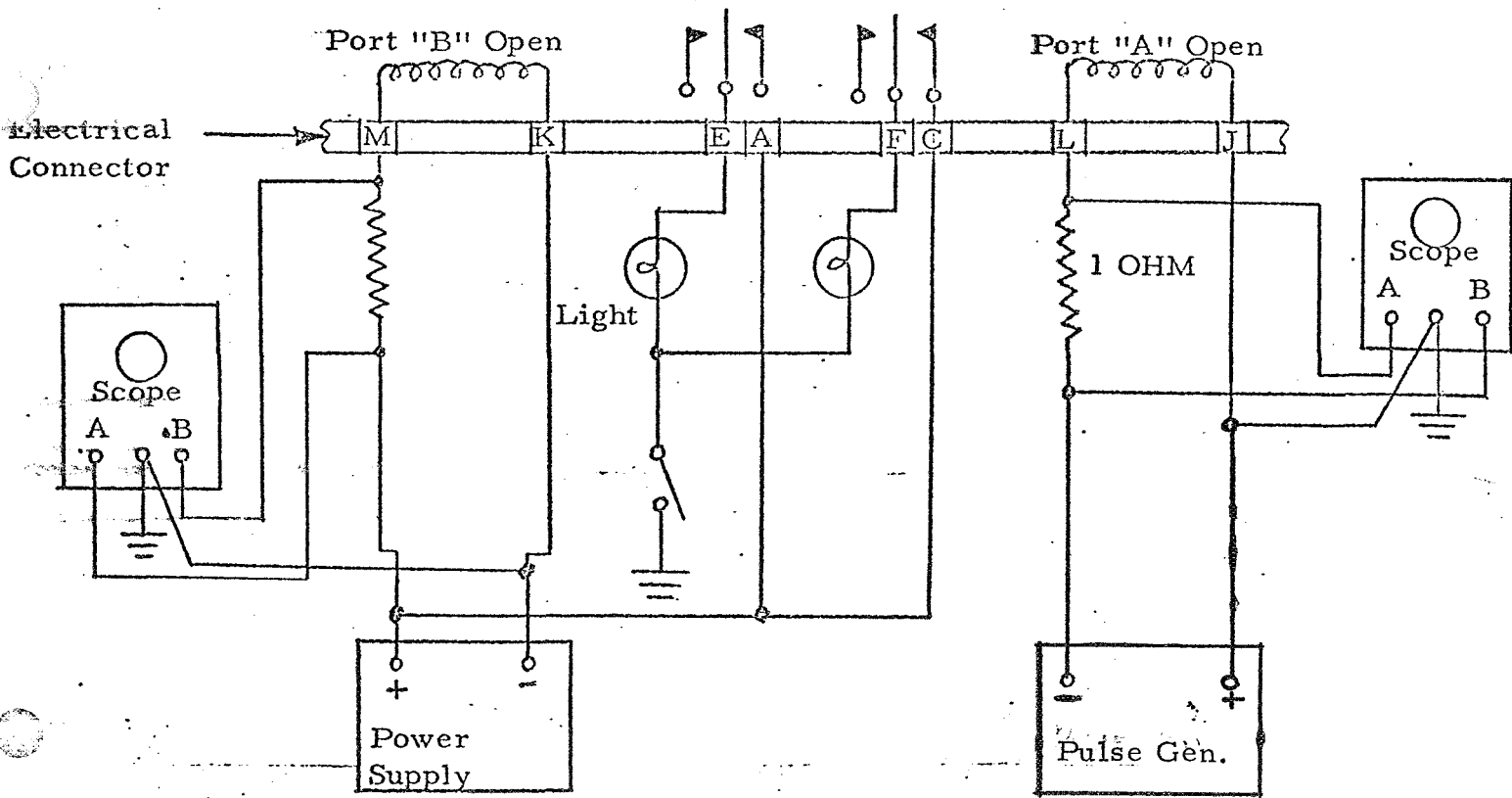
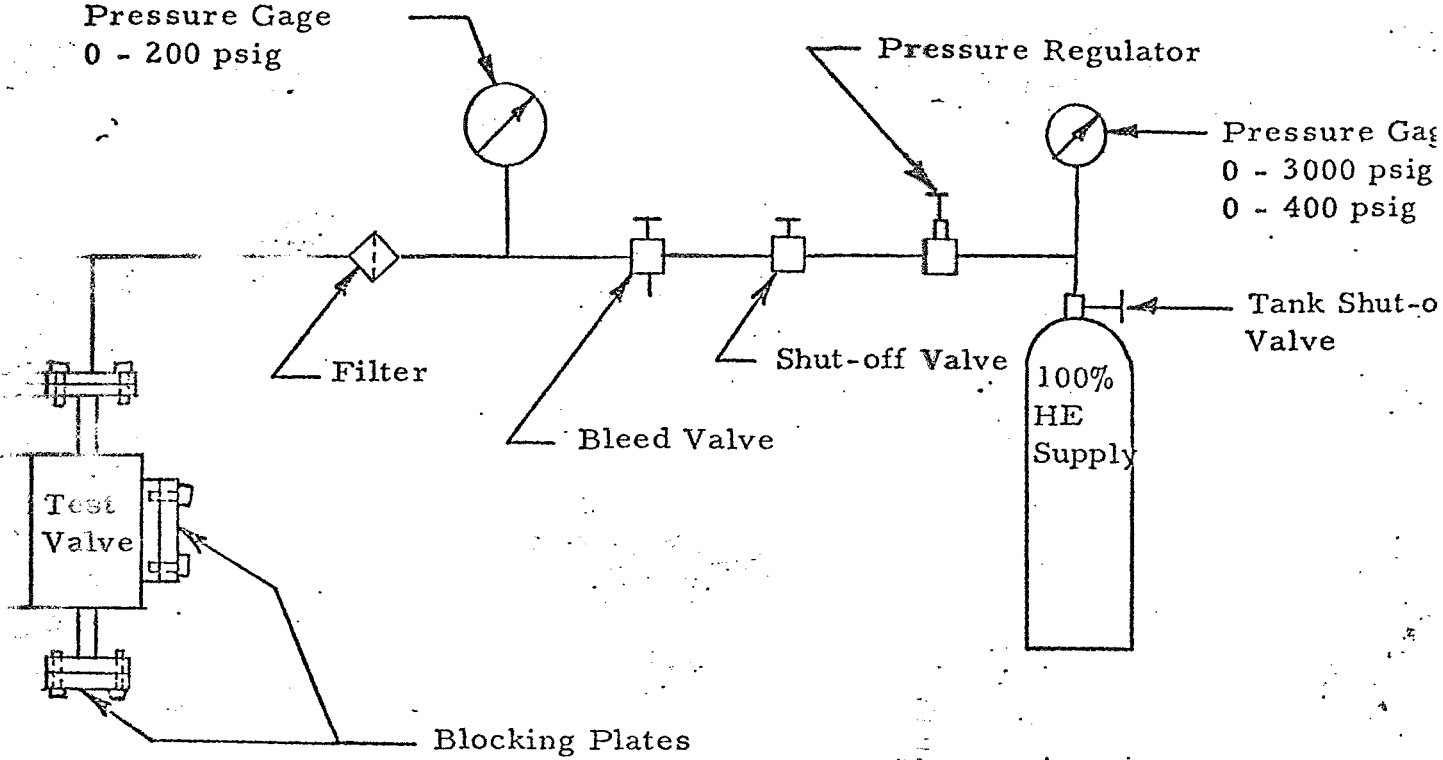

Transient Pulses  
Flow Diverter Valve, Methanol/Water  
Specification 20M42517

Figure 8

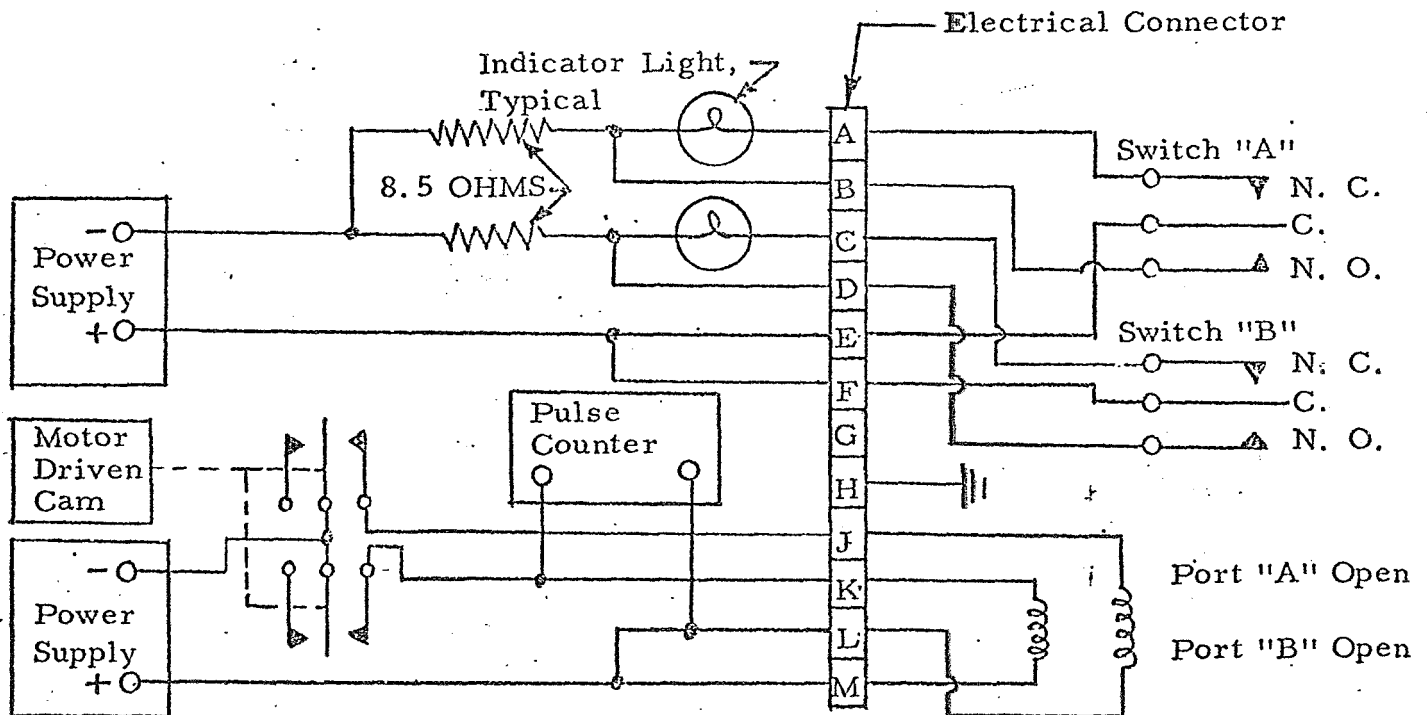
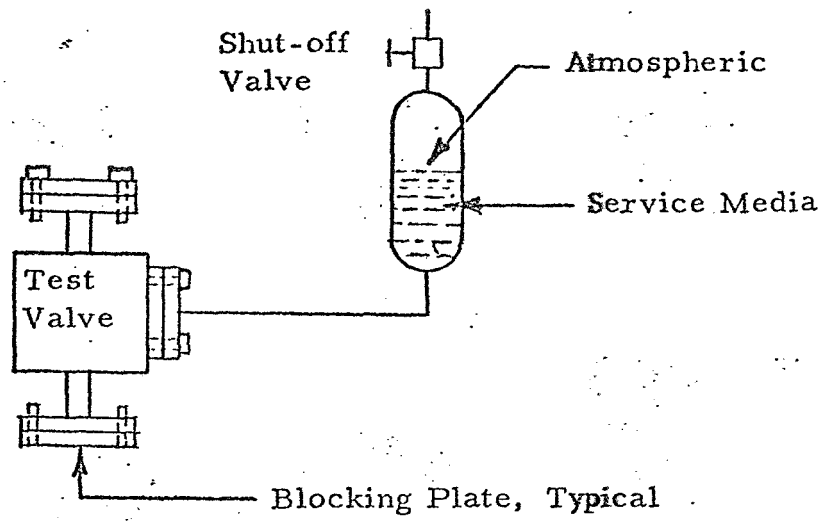

Life Cycling Test  
 Flow Diverter Valve, Methanol/Water  
 Specification 20M42517

Figure 9

Note: Refer to Figures listed below for Functional Tests

Internal Leakage, Liquid - Figure 2

Minimum Voltage, - Figure 5

Pulse Duration, - Figure 5

Power, - Figure 6

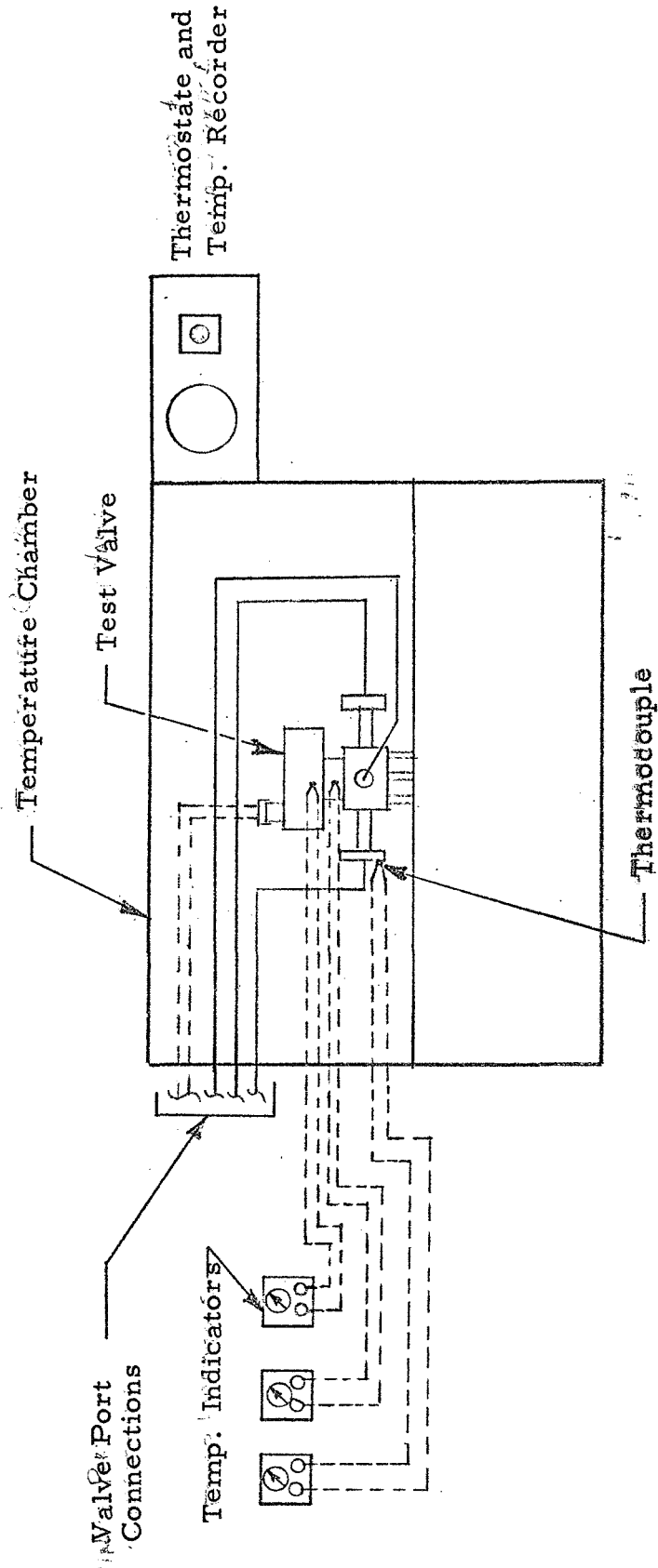

High Temperature Test  
Flow Diverter Valve, Methanol/Water  
Specification 20M42517.17

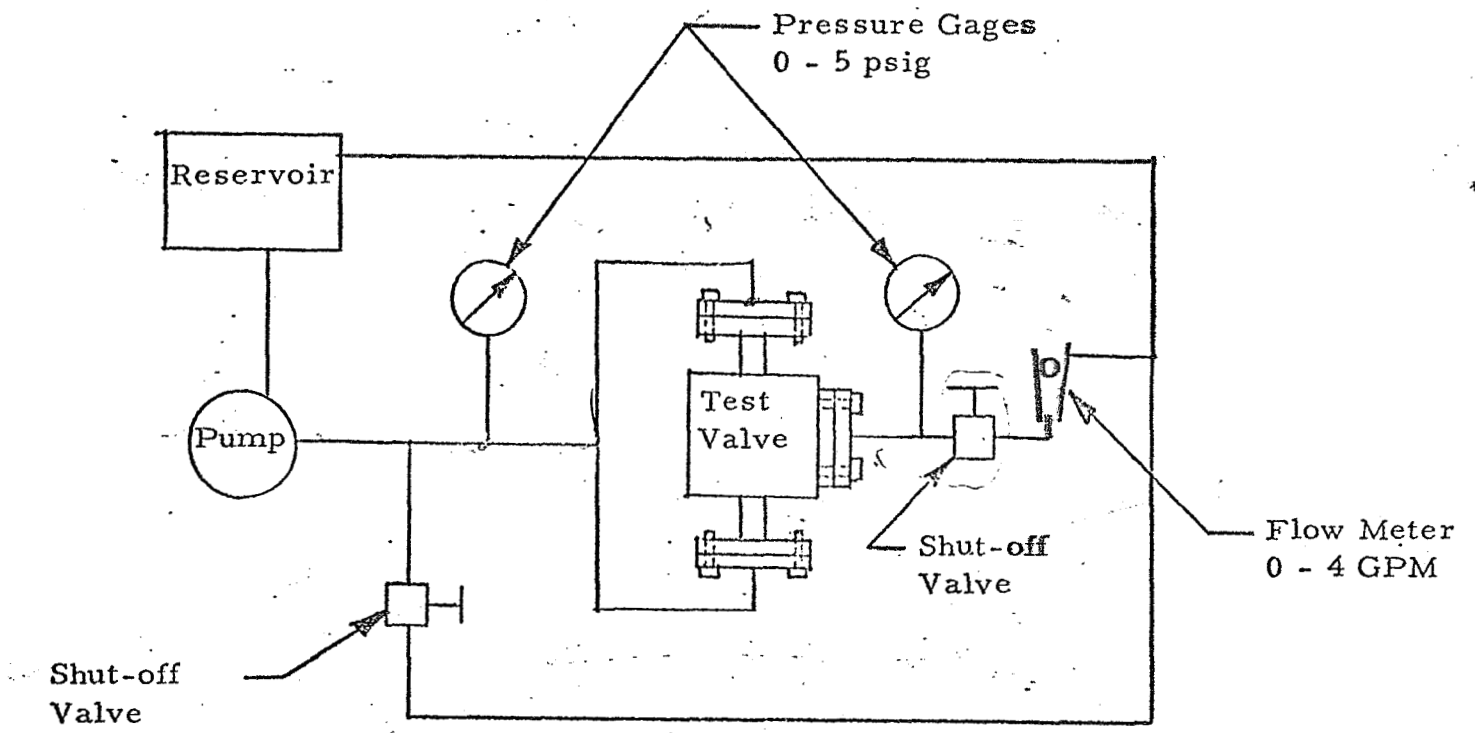

Full Flow Test  
 Flow Diverter Valve, Methanol/Water  
 Specification 20M42517

Figure 11

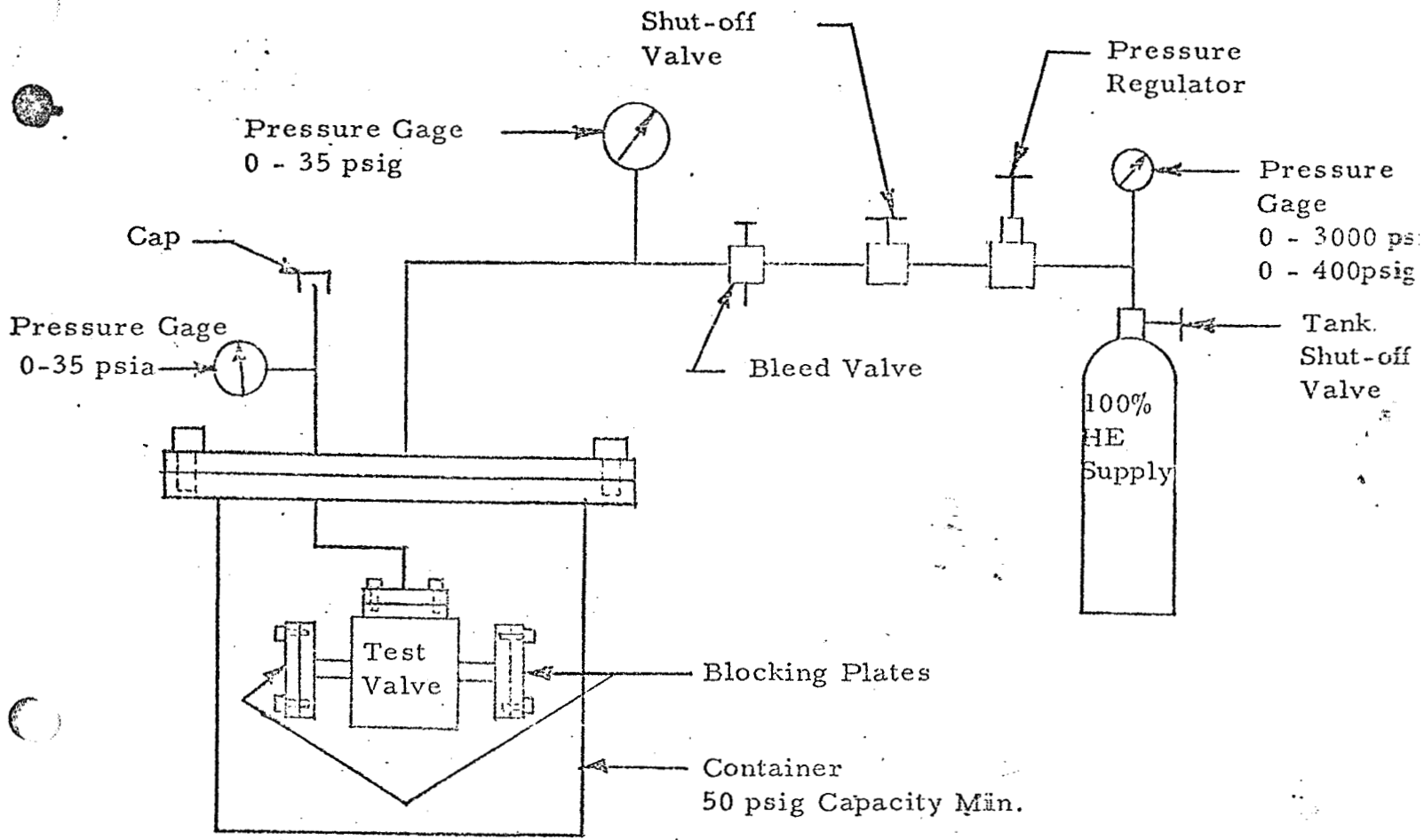

Collapse Pressure Test  
 Flow Diverter Valve, Methanol/Water  
 Specification 20M42517

Figure 12

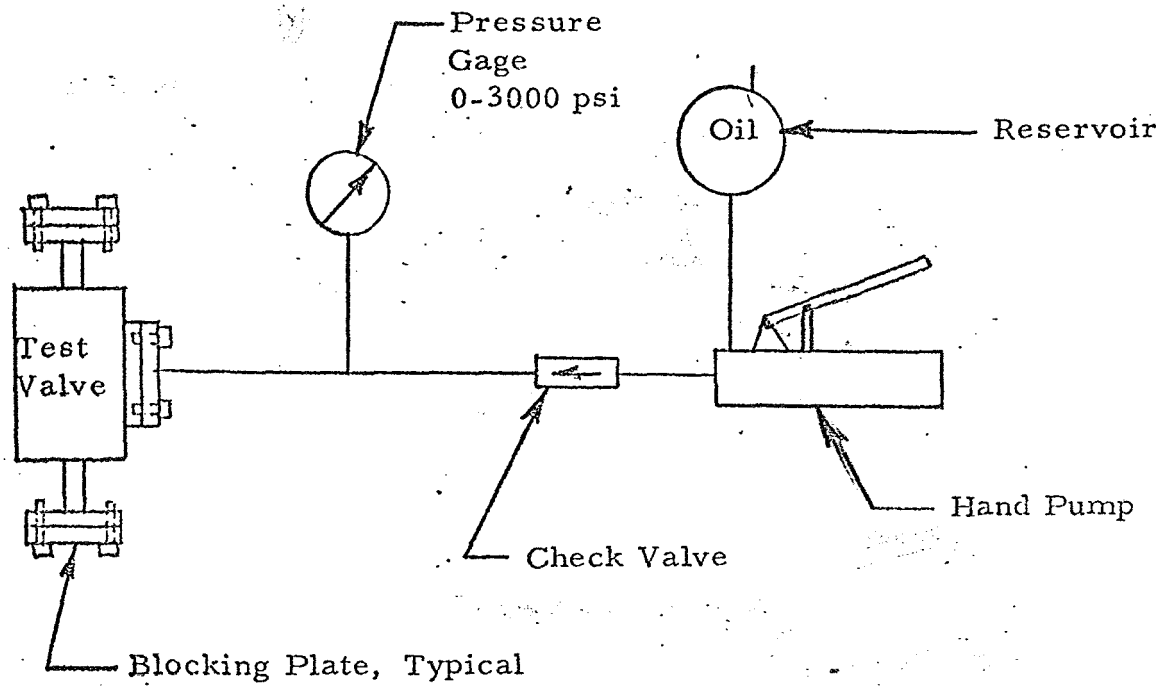

Burst Pressure Test  
 Flow Diverter Valve, Methanol/Water  
 Specification 20M42517

Figure 13

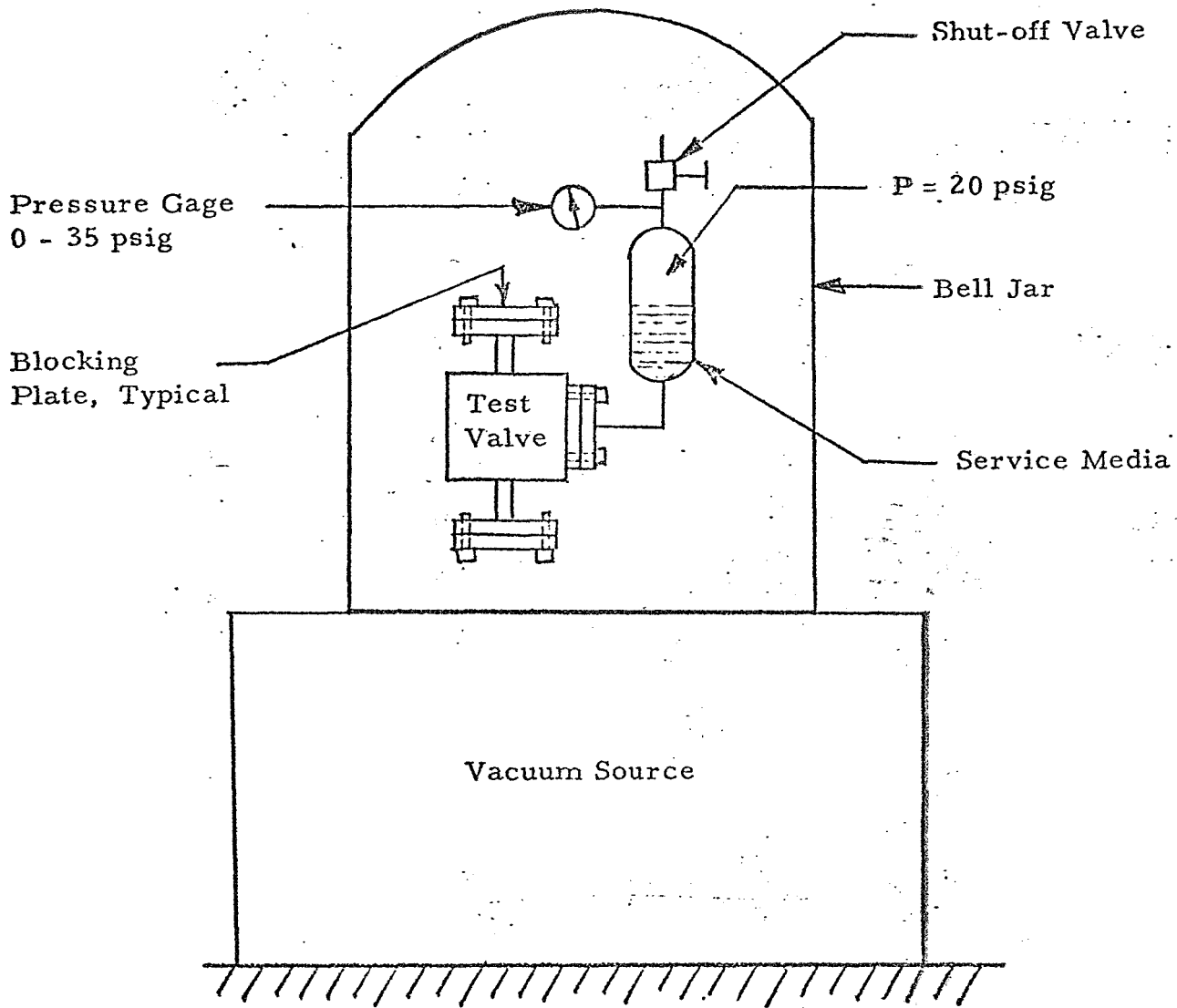

Compatibility Test  
 Flow Diverter Valve, Methanol/Water  
 Specification 20M42517

Figure 14

Humidity Cycle

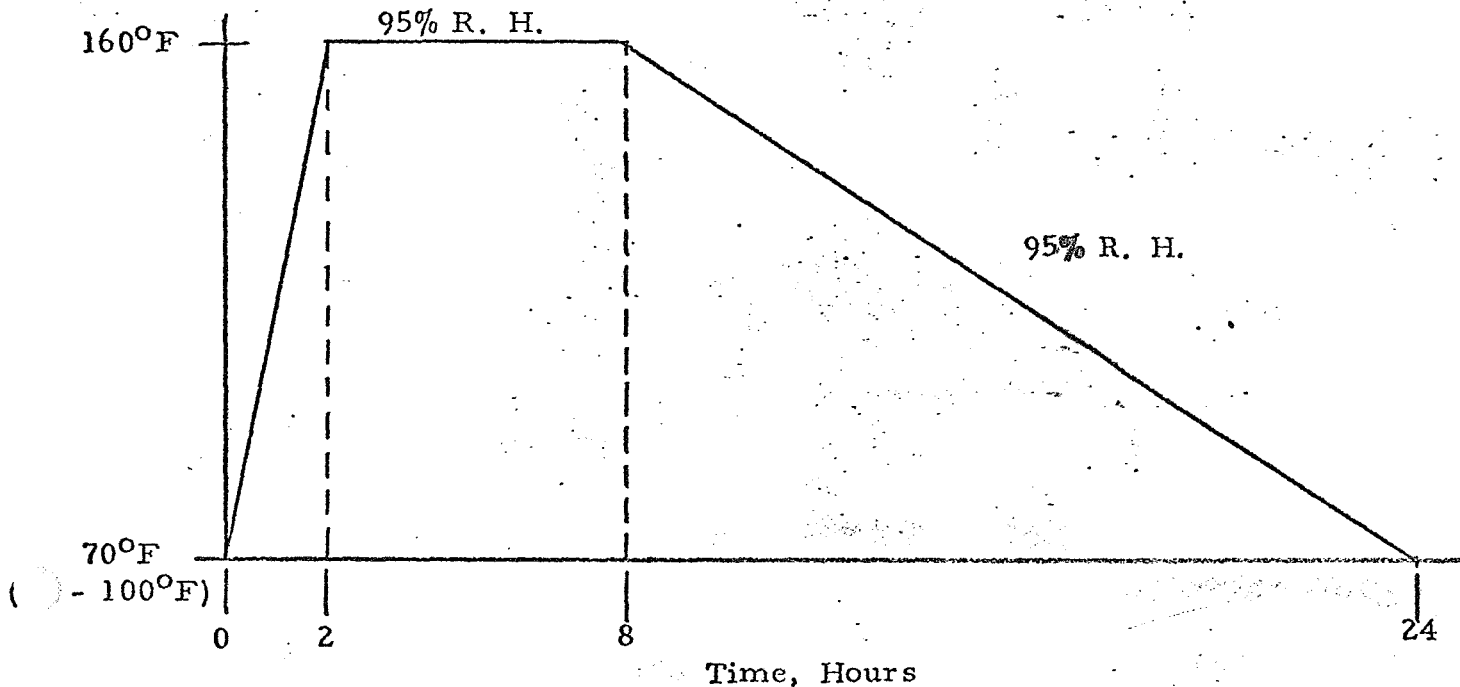

- NOTE: 1. Relative humidity to be raised to 95% during first 2 hours  
2. Required No. of cycles = 10

Humidity Test  
Flow Diverter Valve, Methanol/Water  
Specification 20M42517

Figure 15



Notes: Refer to figures listed below for functional tests.

Internal Leakage - Figure 2

Minimum Voltage - Figure 5

Pulse Duration - Figure 5

Power - Figure 6.

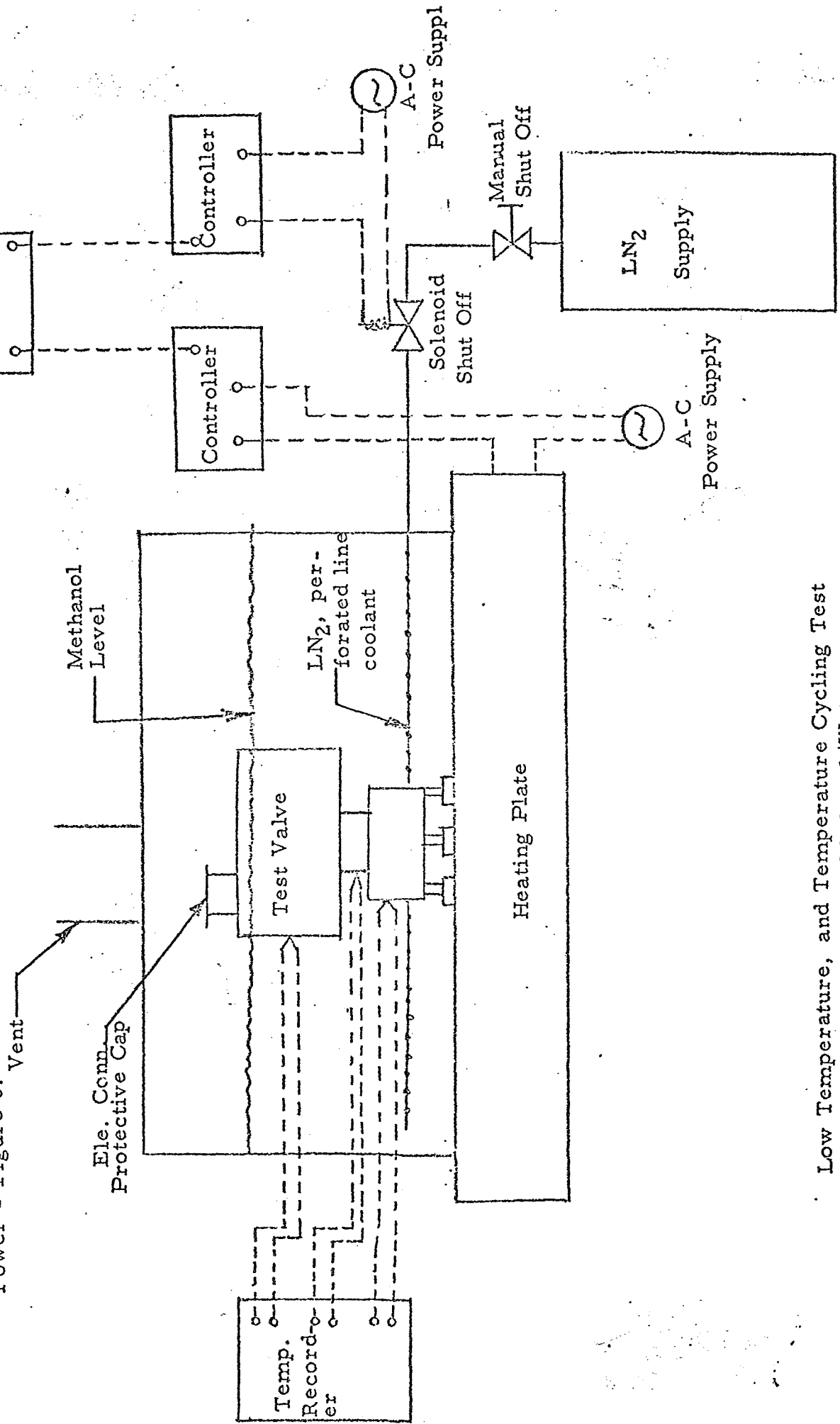

Low Temperature, and Temperature Cycling Test  
Flow Diverter Valve, Methanol/Water  
Specification 20M42517

Figure 16.

NOTICE--When Government drawings, specifications, or other data are used for any purpose other than in connection with a definitely related Government procurement operation, the United States Government thereby incurs no responsibility nor obligation whatsoever; and the fact that the Government may have formulated, furnished, or in any way supplied the said drawings specifications or other data is not to be regarded by implication or otherwise as in any manner licensing the holder or any other person or corporation, or conveying any rights or permission to manufacture, use, or sell any patented invention that may in any way be related thereto.

APPLICATION		PART NO.	MF	REVISIONS			
NEXT ASSY	USED ON			SYM	DESCRIPTION	DATE	APPROVAL

#, \* Indicates change or new material

C Rewritten 11-14-69 *f.w. li.*

VALVE ASSEMBLY, FLOW PATH SELECTOR,  
ELECTRICAL PULSE OPERATED  
DESIGN PROCUREMENT DRAWING

UNLESS OTHERWISE SPECIFIED DIMENSIONS ARE IN INCHES TOLERANCES ON: FRACTIONS DECIMALS ANGLES	ORIGINAL DATE OF DRAWING 2-5-68	VALVE ASSEMBLY, FLOW PATH SELECTOR, ELECTRICAL PULSE OPERATED DESIGN PROCUREMENT DRAWING	GEORGE C. MARSHALL SPACE FLIGHT CENTER NATIONAL AERONAUTICS AND SPACE ADMINISTRATION HUNTSVILLE, ALABAMA	
	DRAFTSMAN			CHECKER
	TRACER			CHECKER
	ENGINEER <i>[Signature]</i>	ENGINEER		
HEAT TREATMENT	SUBMITTED <i>[Signature]</i>			
FINAL PROTECTIVE FINISH	APPROVED <i>[Signature]</i>	SCALE	DWG SIZE	
			A	
			20M42517	
			SHEET 1 OF 28	

SYM	DESCRIPTION	DATE	APPROVAL
-----	-------------	------	----------

B No Change

TABLE OF CONTENTS

	Page
1. SCOPE	5
2. APPLICABLE DOCUMENTS	5
3. DESIGN REQUIREMENTS	8
3.1 General Description	8
3.2 System Configuration and Parameters	8
3.3 Characteristics	10
3.3.1 Pressure Drop	10
3.3.2 Operating Pressures	11
3.3.3 Proof Pressures	11
3.3.4 Burst Pressure	11
3.3.5 Vacuum	11
3.3.6 Collapse Pressure	11
3.3.7 Leakage	11
3.3.8 Insulation Resistance	11
3.3.9 Circuit Resistance	11
3.3.10 Minimum Operating Voltage	12
3.3.11 Pulse Duration	12
3.3.12 Power	12
3.3.13 Duty Cycle	12
3.3.14 Life Cycle	12
3.3.15 Temperature	12
3.3.16 Orbital Vacuum	12
3.3.17 Transient Pulses	12
3.4 Configuration	12
3.4.1 Materials and Part Selection	12
3.4.2 Electrical Connector	13
3.4.3 Position Indicating Switches	13
3.4.4 Lockwiring	13
3.4.5 Product Marking	13
3.4.6 Bifilar Windings	13
3.4.7 Weight	13
3.4.8 Envelope	13
3.5 Construction	13
3.5.1 Cleaning	13
3.5.2 Anodizing	13
3.5.3 Welding	14
3.5.4 Weld Inspection Acceptance	14
3.5.5 Lubrication	14
3.5.6 Soldering	14
3.5.7 Age Control	14

CODE IDENT NO	DWG SIZE	20M42517
	A	SHEET 2 of 28

B No Change

3.5.8	Forgings	14
3.5.9	Castings	14
3.5.10	Grounding	14
3.5.11	Manufacturing Processes	14
3.5.12	Workmanship	14
3.6	Testing	14
3.7	Special Environments	15
3.8	Human Engineering	15
3.9	Design Analysis	15
3.10	Detail Design	15
3.11	Reliability	16
3.12	Identification for Traceability	16
3.13	Requests for Deviation	16
4.	QUALITY ASSURANCE PROVISIONS	16
4.1	Quality Assurance Program	16
4.2	Changes to Design and Processes	16
4.3	Test and Examinations	16
4.3.1	General Requirements	16
4.3.2	Examinations	18
4.3.3	Functional Test	18
4.3.3.1	Proof Pressure	18
4.3.3.2	Vacuum	19
4.3.3.3	Leakage	19
4.3.3.4	Circuit Resistance	19
4.3.3.5	Insulation Resistance	19
4.3.3.6	Position Indications	19
4.3.3.7	Minimum Operating Voltage	19
4.3.3.8	Pulse Duration	19
4.3.3.9	Power	20
4.3.4	Preflight Certification Tests	20
4.3.4.1	Humidity	21
4.3.4.2	Salt Fog	21
4.3.4.3	Sand and Dust	21
4.3.4.4	Fungus Resistance	21
4.3.4.5	Full Flow	21
4.3.4.6	Temperature	21
4.3.4.7	Temperature Cycle	22
4.3.4.8	Compatibility	22
4.3.4.9	Vibration	22
4.3.4.10	Life Cycle	24
4.3.4.11	Acoustical Noise	24
4.3.4.12	Transient Pulses	24
4.3.4.13	Collapse Pressure	24
4.3.4.14	Burst Pressure	24
4.3.4.15	Coil Transient Voltage	24

CODE IDENT NO	DWG SIZE A	20M42517
		SHEET 3 of 28

REVISIONS

SYM	DESCRIPTION	DATE	APPROVAL
-----	-------------	------	----------

B No Change

TABLE OF CONTENTS (CONTINUED)

4.3.5	Acceptance Tests	25
4.3.6	Quality Assurance Sample Tests	25
5.	PREPARATION FOR DELIVERY	26

CODE IDENT NO	DWG SIZE	20342517
A		SHEET 4 of 28

## REVISIONS

SYM	DESCRIPTION	DATE	APPROVAL
-----	-------------	------	----------

1. SCOPE

B No Change

1.1 Coverage. - This drawing covers an electrical pulse operated flow path selector valve assembly.

1.2 Intended use. - The valve assembly is intended to be used in the temperature control system (TCS) of the Apollo Telescope Mount (ATM).

2. APPLICABLE DOCUMENTS.

2.1 Listing. - The following documents, of the issue noted, form a part of this drawing to the extent specified herein. In those cases where the document issue is noted, the issue in effect on date of invitation for bids shall be applicable.

SPECIFICATIONSMilitary

MIL-A-8625

Anodic Coatings for Aluminum and Aluminum Alloys

MIL-R-45774

Radiographic Inspection, Soundness Requirements for Fusion Welds in Aluminum and Magnesium Missile Components

George C. Marshall Space Flight Center

MSFC-SPEC-135

Welding, Fusion, Specification For

MSFC-SPEC-144

Aluminum Alloy Forgings, Premium Quality, Heat Treated, Specification For

MSFC-SPEC-164

Cleanliness of Components for use in Liquid Oxygen, Fuel and Pneumatic Systems, Specification For

MSFC-DWG-10509306

Radiographic Inspection Procedures and Acceptance Standards for Fusion Welded Joints in Stainless and Heat Resistant Steel, Specification For

MSFC-DWG-10509308

Welding, Carbon, Low Alloy, and Stainless Steel, Manual or Automatic, Specification For

MSFC-DWG-20M42501

Methanol/Water, ATM TCS

MSFC-DWG-40M39569

Connector, Electrical, Miniature, Circular, Environmental Resisting, 200°C.

CODE	DWG	20M42517
IDENT NO	SIZE	
	A	SHEET 5 of 28

## REVISIONS

SYM	DESCRIPTION	DATE	APPROVA
-----	-------------	------	---------

B No Change

STANDARDSMilitary

MIL-STD-130	Identification Marking of U.S. Military Property
MIL-STD-143	Specifications and Standards, Order of Precedence for the Selection of
MIL-STD-810A	Environmental Test Methods for Aerospace and Ground Equipment
MIL-STD-831	Test Reports, Preparation of
MS-33586	Metals, Definition of Dissimilar

George C. Marshall Space Flight Center

MSFC-DWG-1041909	Drill Data, Lockwire, Size and Method of Application, Standard for
MSFC-STD-100	Castings, Aluminum and Magnesium Alloy, Radiographic Inspection of, Acceptance Standard For
MSFC-STD-105	Synthetic Rubber, Age Control of, Standard For

DRAWINGSGeorge C. Marshall Space Flight Center

MSFC-DWG-20M30514	Reliability Engineering Requirements for Suppliers of ATM Components
MSFC-DWG-20M42522	Fitting End, ATM TCS
MSFC-DWG-50M02442	ATM Materials Control for Contamination Due to Outgassing
MSFC-DWG-50M12725	Apollo Telescope Mount Electromagnetic Compatibility Control Plan
MSFC-DWG-50M02408A	Environmental Design and Qualification Test Criteria for Apollo Telescope Mount Components

CODE IDENT NO	DWG SIZE A	20M42517 SHEET 6 of 28
---------------	---------------	---------------------------

REVISIONS

SYM	DESCRIPTION	DATE	APPROVAL
-----	-------------	------	----------

B No Change

PUBLICATIONS

George C. Marshall Space Flight Center

MSFC Engineering Standards Manual

Identification for Traceability (Quality and Reliability Assurance Laboratory)

SR-QUAL-67-29 MSFC Supplement to NPC 200-4, Supplier Soldering Program

National Aeronautics and Space Administration

NPC 200-2 Quality Program Provisions for Space Systems Suppliers

NPC 200-3 Inspection Systems Provisions for Suppliers of Space Materials, Parts, Components, and Services

NPC 200-4 Quality Requirements for Hand Soldering of Electrical Connections

(Copies of Specifications, Standards, Procedures, Drawings, and Publications required by contractors in connection with specific procurement functions should be obtained from the procuring activity or as directed by the contracting officer).

OTHER PUBLICATIONS

Consolidated Classification Committee

Uniform Freight Classification Rules

(Applications for copies should be addressed to the Consolidated Classification Committee, 1 Park Avenue at 33rd. Street, New York 16, N.Y.).

American Trucking Association

National Motor Freight Classification Rules

(Application for copies should be addressed to the American Trucking Association, 1616 P Street, N.W., Washington 6, D.C.)

2.2 Order of precedence. - Unless otherwise specified by the procuring activity, in the event of conflicts between documentation the order of precedence shall be as follows:

- (a) Contractual documentation (purchase order)
- (b) This Design Procurement Drawing

CODE IDENT NO	DWG SIZE	2042517
A		SHEET 7 of 28



## REVISIONS

SYM	DESCRIPTION	DATE	APPROVAL
C	Change	11-14-69	

- (c) MSFC Standards, Specifications and Procedures
- (d) NASA Publications
- (e) Military Standards and Specifications
- (f) Other Publications

Specifications and Standards for necessary commodities and service not provided in the procurement documentation shall be selected in accordance with MIL-STD-143.

### 3. DESIGN REQUIREMENTS

3.1 General description.- The assembly shall be a two position, electrical pulse operated valve. The schematic is shown in Figure 1. On the application of a pulse the valve assembly shall move from the primary to the secondary position.

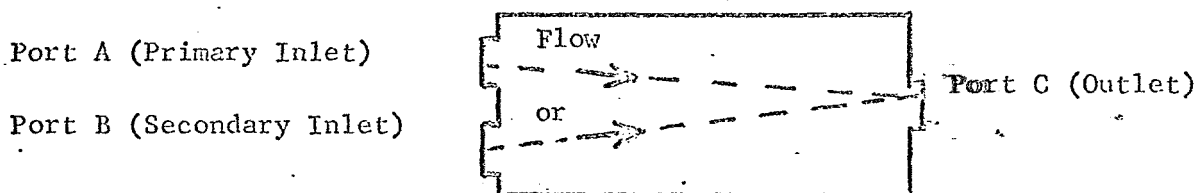

Figure 1. - Schematic

On the application of another pulse the valve assembly shall return to the primary position. The valve assembly shall provide a means to prevent inadvertent changes of position. The valve assembly shall have position indicating switches at both the primary and secondary positions.

3.1.1 Systems voltage.- The valve assembly shall operate from a 22 to 30 vdc system with 28 vdc nominal.

3.1.2. Service Media.- The service media shall be as follows:

- (a) Air
- (b) Helium (He)
- (c) Gaseous Nitrogen (GN<sub>2</sub>)

(d) Liquid service media.- Methanol/water mixture (80% by weight methanol; 20% by weight demineralized water) which is in accordance with Specification 20M42501. Maximum particle size shall not be greater than 400 microns.

3.1.3 The valve shall operate, and/or remain latched in the last position with a \* differential pressure of 20 psi from either inlet port to the other. The valve shall operate with a power pulse of 45 watts or less. The power pulse requirement shall not exceed 4 seconds duration.

3.2 System configuration and parameters.

3.2.1. System configuration.- The valve assembly is to be installed in a temperature control system as shown in Figure 2. The final decision regarding the selection of the arrangements shown in details A and B has not been made.

CODE	.DWG	20M42517
IDENT NO	SIZE	

REVISIONS			
SYM	DESCRIPTION	DATE	APPROVAL

B No Change

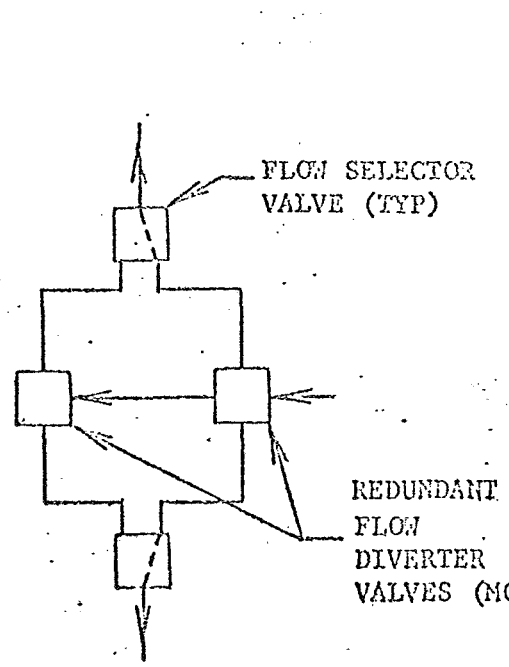
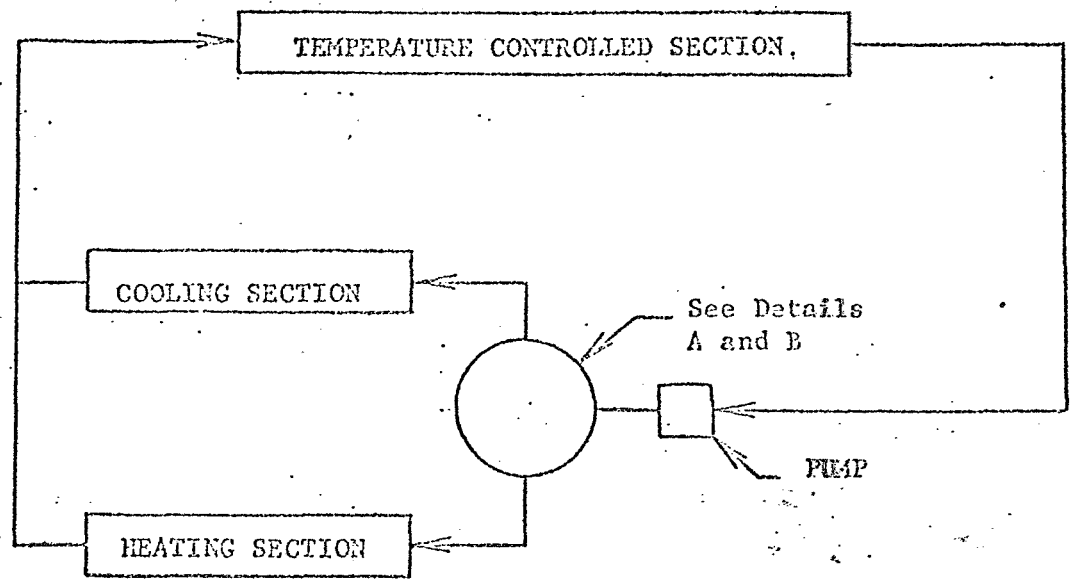

DETAIL A.

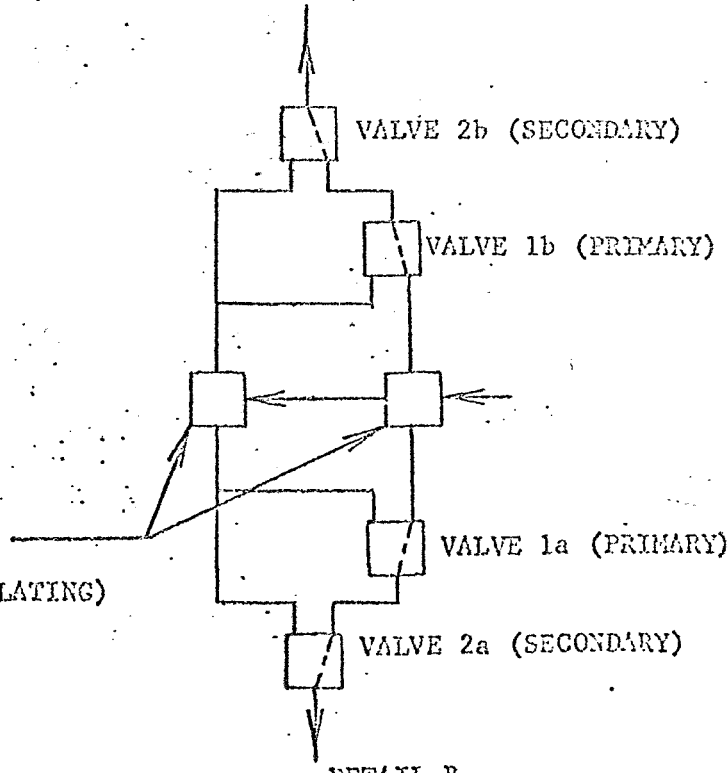

DETAIL B

FIGURE 2.- SYSTEM CONFIGURATION

CODE IDENT NO	DWG SIZE	20M42517
	A	SHEET 9 of 28

## REVISIONS

SYM	DESCRIPTION	DATE	APPROVA
-----	-------------	------	---------

B No Change

3.2.2 System operation. - The redundant flow diverter valves are operated by redundant temperature controllers. The controllers modulate the diverter valves on the basis of the temperature of the inlet to the temperature controlled section. Only one set of controllers and diverter valves is energized at any time. When a change is made from one set to the other set the flow selector valves are actuated to the opposite position in the case of the system shown in Detail A. In the case of Detail B the primary valves would be actuated. The secondary valves would be actuated if one or both of the primary valves failed to actuate properly.

NOTE

In the case of the system shown in Detail B the primary flow selector valves may be mechanically linked with operation by one actuating mechanism. A similar situation exists for the secondary valves.

3.2.3 System mission. - The system mission is projected to be as follows:

- (a) 42 days of ground operation
- (b) 236 days operation in orbit
- (c) 60 days storage in orbit, completely inactive

3.2.4 Criticality of failure modes. - The valve assembly is considered to be an engineering critical portion of the temperature control system. Possible failure modes of the valve assembly are listed in the order of decreasing criticality as follows:

- (a) Failure which results in loss of structural integrity
- (b) Failure which results in an inadvertent change of position
- (c) Failure which prevents proper operation upon the application of an actuating pulse.
- (d) Failure which results in excessive leakage.

### 3.3 Characteristics.

✓ 3.3.1 Pressure drop. - In either position the pressure drop across the valve assembly shall be 0.5 psi maximum at a flow rate of 900 pounds per hour of the liquid service media, and a inlet temperature of 50°F.

CODE IDENT NO	DWG SIZE	20442517
	A	SHEET 10 of 28

## REVISIONS

SYM	DESCRIPTION	DATE	APPROVAL
C	Change	11-13-69	

3.3.2 Operating pressures.- The valve assembly shall operate without failure at internal pressures from zero to 50 psig.

## NOTE

Failure shall consist of any damage, excessive permanent distortion, deterioration, nonconformance to specified requirements or change in characteristics that could in any way prevent the valve assembly from meeting the requirements specified herein.

3.3.3 Proof pressures.- The valve assembly shall withstand without failure an internal pressure of 75 psig.

3.3.4 Burst Pressure.- The valve assembly shall withstand without rupture an internal pressure of 125 psig.

3.3.5 Vacuum.- The valve assembly shall withstand without failure being evacuated to 0.01 psia or less while in a normal ground level atmosphere.

3.3.6 Collapse pressure.- The valve assembly shall withstand without collapse an external pressure of 19 psig with normal ground level atmospheric pressure as the internal pressure.

\*3.3.7 Leakage.- Leakage shall be as follows:

(a) External.- The maximum allowable external leakage of the valve assembly including fitting interface with internal pressures from zero to 50 psig shall be as follows:

(1) Gaseous.-  $1.6 \times 10^{-6}$  sccs He

(2) Liquid.- None

(b) Internal - The maximum allowable internal leakage from one inlet port to the other at differential pressures from zero to 20 psi shall be as follows:

(1) Liquid -  $2 \times 10^{-1}$  ccs of the liquid service media.

3.3.8 Insulation resistance.- Insulation resistance shall be 50 megohms minimum at 500 vdc as follows:

(a) From each terminal pin of the electrical connector(s) to the body of the valve assembly.

(b) Between terminal pins which are connected to position switches with the contacts fully open.

(c) Between the terminal pins which are not connected electrically.

3.3.9 Circuit resistance.- The resistance of the position switch circuits at the electrical connector(s) with the switch contacts closed shall be 0.5 ohm maximum.

CODE IDENT NO	DWG SIZE	20M42517
	A	SHEET 11 of 28

SYM	DESCRIPTION	DATE	APPROVAL
B	Change	3-05-69	

3.3.10 Minimum operating voltage. - With inlet pressures from zero to 50 psig and flow rates of the liquid service media from zero to 900 pounds per hour the valve assembly shall move from the primary to the secondary position or vice versa when pulsed from a supply voltage of 18.0 vdc maximum.

3.3.11 Pulse duration. - The pulse duration required for proper operation shall be minimized. The minimum pulse durations for proper operation correlated with supply voltages from 18 to 30 vdc and with the operating temperature range shall be submitted to and approved by the procuring activity.

3.3.12 Power. - Power requirements shall be minimized. Peak and steady state currents with tolerances correlated with supply voltages from 22 to 30 vdc and with the operating temperature range shall be submitted to and approved by the procuring activity.

3.3.1.3 Duty cycle. - The valve assembly shall withstand without failure being energized continuously with 30.0 vdc for 5 minutes followed by a return to the operating temperature. Duty cycle limitation characteristics (i.e. cycle rate and pulse duration versus number of cycles, etc.) shall be submitted to and approved by the procuring activity.

3.3.14 Life cycle. - The valve assembly shall withstand without failure a minimum of 1000 cycles of operation.

3.3.15 Temperature. - The valve assembly shall operate without failure at temperatures ranging from minus 65 to plus 165°F.

3.3.16 Orbital vacuum. - The valve assembly shall operate without failure at external pressures down to  $1.5 \times 10^{-6}$  Torr.

3.3.17 Transient pulses. - The valve assembly shall operate without failure with positive or negative pulses as defined in figure 3 present on the supply or return leads.

3.4 Configuration. - The valve assembly shall be capable of being mounted to a flat plate with through bolts and nuts. The ports and the electrical connector(s) shall be above the mounting plane. All joints which could allow external leakage shall be semipermanently or permanently joined. The fitting ends of the valve assembly shall be in accordance to Drawing 20M42522.

3.4.1 Materials and part selection.

3.4.1.1 Materials. - Unless otherwise specified by the procuring activity, the selection of materials shall be made by the supplier. The supplier shall avoid the selection of materials which have not demonstrated their suitability for the environments or applications. A list of candidate materials and corresponding proposed applications shall be submitted to the procuring activity for review. All materials shall be approved by the procuring activity prior to use. Materials listed as not acceptable in Drawing 50M02442 shall not be used.

CODE IDENT NO	DWG SIZE	20M42522
	A	SHEET 12 OF 23

## REVISIONS

SYM	DESCRIPTION	DATE	APPROVAL
B	Change	3-05-69	

3.4.1.1.1 Metals. - Metals shall be corrosion resistant alloys. Dissimilar metals, defined in Standard MS33586, shall not be used in combination unless they are suitably coated to prevent electrolytic corrosion. Metals which may contact the service media shall be 300 series corrosion resistant steel, 5000 or 6000 series aluminum alloy, or 356 aluminum alloy castings. Corrosion resistant steel, if used, shall not be susceptible to carbide precipitation during welding, brazing, and stress relieving.

3.4.1.1.2 Wire. - Electrical wire shall be approved by the procuring activity.

3.4.1.2 Standard parts. - Unless otherwise specified by the procuring activity, standard parts as specified in the MSFC Engineering Standards Manual shall be used wherever applicable. In those applications where no suitable standard parts exist in the Engineering Standards Manual on the date of invitation for bids other parts may be used provided they are approved by the procuring activity.

3.4.2 Electrical connector. - The electrical connector(s) shall be in accordance with Specification 40M39569. The electrical connector shall be ITT Cannon part number PV7H14B12PNC or equivalent. Pin functions shall be as shown in Figure 4. A mating connector shall be supplied with each valve assembly.

3.4.3 Position indicating switches. - The position indicating switches shall have characteristics as follows:

- (a) Hermetically sealed
- (b) Single pole double throw
- (c) Current rating: 3 amperes minimum resistive at 28 vdc

3.4.4 Lockwiring. - Threaded fasteners which can be lockwired shall be lockwired in accordance with standard 10419909. Threaded fasteners which cannot be lockwired shall be locked with another approved locking device.

3.4.5 Product marking. - Product marking shall be in accordance with Standard MIL-STD-130. Similarly, the ports shall be identified.

3.4.6 Bifilar windings. - Coils shall have bifilar suppression windings.

3.4.7 Weight. - The valve assembly shall weigh as little as practically possible

3.4.8 Envelope. - The envelope dimensions of the valve assembly shall be as small as practically possible.

### 3.5 Construction.

3.5.1 Cleaning. - The valve assembly shall be cleaned in accordance with Specification MSFC-SPEC-164, fuel service, except the maximum allowable particle size shall be 175 microns.

3.5.2 Anodizing. - Anodizing of aluminum alloy parts shall be in accordance with Specification MIL-A-8625.

CODE IDENT NO	DWG SIZE	20M42517
	A	SHEET 13 of 28

## REVISIONS

SYM	DESCRIPTION	DATE	APPROVAL
-----	-------------	------	----------

B No Change

3.5.3 Welding. - Welding shall be in accordance with the documentation as follows:

- (a) Aluminum alloy - Specification MSFC-SPEC-135
- (b) Corrosion resistant steel - Specification 10509308

3.5.4 Weld inspection and acceptance. - Weld inspection and acceptance shall be in accordance with documentation as follows:

- (a) Aluminum alloy - Specification MIL-R-45774
- (b) Corrosion resistant steel - Specification 10509306

3.5.5 Lubrication. - Lubricants, if used, shall be approved by the procuring activity.

3.5.6 Soldering. - Soldering of electrical connections shall be in accordance with NASA Publication NPC 200-4 and MSFC Publication SR-QUAL-67-29.

3.5.7 Age control. - Age control of synthetic rubber, if used, shall be in accordance with Standard MSFC-STD-105.

3.5.8 Forgings. - Aluminum alloy forgings shall be in accordance with Specification MSFC-SPEC-144.

3.5.9 Castings. - Aluminum and magnesium alloy castings shall be in accordance with Standard MSFC-STD-100.

3.5.10 Grounding. - Grounding provisions shall be in accordance with Drawing 50M12725.

3.5.11 Manufacturing processes. - Critical detailed manufacturing processes used in the manufacture of the valve assembly shall be submitted to and approved in writing by the procuring activity.

3.5.12 Workmanship. - The valve assembly shall be free of cross threading, burrs, scratches, cracks, breaks, pits, dents, chips, sharp projections, sharp edges, loose parts, loose electrical components, loose solder or foreign material that may adversely affect performance, reliability, safety, endurance or wear.

3.6 Testing. - The valve assembly shall meet the requirements specified herein during the testing specified in Section 4. The valve assembly shall withstand the nondestructive tests without failure. Burst and collapse pressure testing shall be considered the only destructive tests.

CODE IDENT NO	DWG SIZE	20M42517
	A	SHEET 14 of 28

REVISIONS

SYM	DESCRIPTION	DATE	APPROVAL
-----	-------------	------	----------

B                      No Change

3.7 Special environments.- The valve assembly shall withstand the following environmental conditions with failure. Unless otherwise specified by the procuring activity, tests to determine conformance to these requirements are not required.

(a) Transportation: Exposure to pressures ranging from 4.36 psia to 14.7 psia and simultaneous change in temperature from plus 165°F to minus 65°F.

(b) Storage: Minimum storage time of two years with ambient temperatures ranging from zero to plus 140 degrees F and relative humidity to 100 percent with condensation in the form of both water and frost.

3.8 Human engineering.- The principles of human engineering shall apply during manufacture, test, maintenance and all operations where personnel are involved. The design shall incorporate those human engineering features that minimize the possibility of degrading reliability through human error.

3.9 Design analysis.- A design analysis shall be submitted to and approved in writing by the procuring activity. This design analysis shall include but is not limited to the following:

- (a) Operating stress levels for all environments
- (b) Safety factors

This design analysis shall be revised and resubmitted to the procuring activity periodically incorporating all changes.

3.10 Detail design.- A detailed design shall be submitted to and approved in writing by the procuring activity. This detailed design shall include but is not limited to the following:

- (a) Manufacturing drawings
- (b) Parts list:
  - (1) Part or identification number
  - (2) Nomenclature or description
  - (3) Material
  - (4) Material specification
  - (5) Heat treat
  - (6) Finish specification

CODE IDENT NO	DWG SIZE	20M42517
	A	SHEET 15 of 28



REVISIONS			
SYM	DESCRIPTION	DATE	APPROVAL

B No Change

3.11 Reliability.

3.11.1 Requirements. - The reliability requirements for the valve assembly shall be as specified in Drawing 20M30514.

3.11.2 Failure Mechanisms. - Any failure mechanism, which could result in a failure in a critical mode, as determined from the failure effect analysis, shall be eliminated from the valve assembly, or reduced to an insignificant probability of occurrence.

3.11.3 Certification. - The supplier of the valve assembly shall certify in an MSFC approved form that the valve assembly, in the configuration delivered, has met the specified requirements and is flight worthy.

3.12 Identification for traceability. - The supplier of the valve assembly shall establish an identification for traceability program. Publication "Identification for Traceability" shall be used as a guide in implementing this program. A list of the parts considered to be critical and the associated degree of traceability to be implemented shall be submitted to the procuring activity for review.

3.13 Requests for deviation. - Requests for deviation to any requirements shall be made by use of MSFC Form 847, Deviation Approval Request.

4.0 QUALITY ASSURANCE PROVISIONS

4.1 Quality assurance program. - The quality assurance program used by the supplier in the production of the valve assembly shall be in accordance with NASA Publication NPC 200-2 and NPC 200-3 as specified by the contractual documentation.

4.2 Changes to design and processes. - The detailed design and the associated manufacturing processes shall not be changed after they have been approved without the prior written approval or written direction of the procuring activity. Any changes shall be evaluated by the procuring activity to determine if additional testing is required.

4.3 Tests and examinations.

4.3.1 General requirements.

4.3.1.1 Responsibility. - Unless otherwise specified by the procuring activity, the supplier shall be responsible for the performance of all the examinations and tests specified herein. The supplier may use his own or any other facilities provided they are approved by the procuring activity. The procuring activity reserves the right to perform any of the examinations or tests specified herein.

CODE IDENT NO	DWG SIZE	20X42517
	A	SHEET 16 of 23

REVISIONS			
SYM	DESCRIPTION	DATE	APPROVAL

4.3.1.2 Documentation.

B No Change

4.3.1.2.1 Test plans.- The acceptance test plan shall be submitted to and approved in writing by the procuring activity. The preflight certification test plan and the quality assurance sample test plan shall be submitted to and approved in writing by the procuring activity when these tests are required. These tests plans shall include but are not limited to the following:

- (a) Testing agencies
- (b) Location of test facilities
- (c) Test schematics including instrumentation and control equipment
- (d) Equipment list
- (e) Test and measuring tolerances
- (f) Detailed procedures

4.3.1.2.2 Test records.- Records of the examinations and tests shall be kept complete and available to the procuring activity.

4.3.1.2.3 Test status reports.- Periodic test status reports shall be submitted to and approved in writing by the procuring activity when required. These test status reports shall cover the preflight certification test and the quality assurance sample tests, as applicable. These reports shall include but are not limited to the following:

- (a) Progress against the test schedules
- (b) General results of accomplished tests
- (c) Failures and corrective measures
- (d) Changes pertinent to the test programs
- (e) Scheduling of subsequent tests

4.3.1.2.4 Test reports.- Final test reports shall be submitted to and approved in writing by the procuring activity. These reports shall cover the preflight certification tests and the quality assurance sample tests, as applicable. These reports shall be in accordance with Standard MIL-STD-831. Any failures and corrective actions shall be included in the test reports.

4.3.1.2.5 Test data sheets.- Test data sheets for valve assemblies subjected to the acceptance tests for acceptance shall be submitted to the procuring activity. These test data sheets shall include but are not limited to the following:

- (a) Name of supplier

CODE IDENTNO	DWG SIZE	20M42517
	A	SHEET 17 of 28

REVISIONS

SYM	DESCRIPTION	DATE	APPROVA
-----	-------------	------	---------

B No Change

- (b) Part numbers of both the supplier and the procuring activity
- (c) Serial numbers of the valve assemblies which were tested.
- (d) Test procedures
- (e) Acceptance requirements
- (f) Actual observed test results
- (g) Certification by the quality control inspector who represents the procuring activity.

4.3.1.3 Order of tests and examination.- The order of tests and examinations shall be at the discretion of the supplier except as otherwise specified herein.

4.3.1.4 Test and examination conditions.- Unless otherwise specified by the procuring activity, the tests and examinations shall be performed under conditions as follows:

- (a) Temperature - Standard temperature, 77 (plus or minus 18) degrees F
- (b) Relative humidity - 90 percent maximum
- (c) Atmospheric pressure - 14.7 (plus or minus 0.7) pounds per square inch absolute (psia)

4.3.1.5 Failure.- The procuring activity shall be notified immediately of any failure during any test or examination. The procuring activity shall also be informed of the possible cause of the failure and the possible corrective actions. These may be the basis for changes to the detail design, manufacturing processes, and test plan. Any changes shall be approved in writing or be directed by the procuring activity.

4.3.2 Examinations.- The valve assemblies shall be examined to check for conformance to 3.1, 3.4, 3.5, 3.9 and 3.10.

4.3.3 Functional tests.- Valve assemblies shall have successfully completed the examinations of 4.3.2 prior to being subjected to these tests. The proof pressure and vacuum tests shall be performed first followed by the remainder of the functional tests.

4.3.3.1 Proof pressure.- Simultaneously, the 3 ports of the valve assembly shall be slowly, internally pressurized to 75 psig. This pressure shall be held for 5 minutes before reducing to zero. The valve assembly shall be checked for conformance to 3.3.3.

CODE IDENT NO	DWG SIZE	20M42517
	A	SHEET 18 of 28

SYM	DESCRIPTION	DATE	APPROVED
-----	-------------	------	----------

B No Change

4.3.3.2 Vacuum.- The 3 ports of the valve assembly shall be simultaneously evacuated to 0.01 psia or less. The vacuum shall be maintained for 5 minutes before returning to atmospheric pressure. The valve assembly shall be checked for conformance to 3.3.5.

4.3.3.3 Leakage.

4.3.3.3.1 External.- The valve assembly shall be tested to check for conformance to 3.3.7(a)(1) with all 3 ports pressurized simultaneously to 50 psig with No.

4.3.3.3.2 Internal.- Internal leakage testing shall be as follows:

(a) Port A

(1) Liquid - with the valve assembly in the secondary position Port A shall be pressurized to 5.0, 10.0, 15.0, and 20 psig with the liquid service media. At each pressure valve assembly shall be checked for conformance to 3.3.7 (b) (1). The valve assembly shall then be cycled from the primary to the secondary back to the primary position a minimum of one time. This procedure shall be performed 3 times.

(2) Gaseous - not applicable.

(b) Port B.- Testing similar to 4.3.3.3.2(a) shall be performed with Port B pressurized.

4.3.3.4 Circuit resistance.- The valve assembly shall be tested to check for conformance to 3.3.9 through 3 cycles of operation minimum.

4.3.3.5 Insulation resistance.- The valve assembly shall be tested to check for conformance to 3.3.8.

4.3.3.6 Position Indications.- The position switches shall be checked for proper indications throughout all the cycling during the functional tests.

4.3.3.7 Minimum operating voltage.- Simultaneously the 3 ports of the valve assembly shall be internally pressurized to 50 psig. Pulses of increasing amplitude shall then be applied until the position of the valve assembly changes. The valve assembly shall be checked for conformance to 3.3.10. The above shall be performed 3 times minimum with the valve assembly in the primary position and also 3 times minimum in the secondary position. The duration of the pulses shall remain constant during this test. The duration of the pulse with tolerance shall be included in the test plan (see 4.3.1.2.1). This test shall then be repeated with the valve assembly unpressurized.

4.3.3.8 Pulse duration.- Simultaneously the 3 ports of the valve assembly shall be internally pressurized to 50 psig. With a supply voltage of 20.0 vdc pulses of increasing duration shall then be applied until the position of the valve assembly changes. The valve assembly shall be checked for conformance to the minimum pulse duration requirements which were approved by the preceding activity (see 3.3.11). The above shall be performed 3 times minimum with the valve assembly in the primary position and also 3 times minimum in the secondary position. This test shall then be repeated with the valve assembly unpressurized.

CODE IDENT NO	DWG SIZE	20M2517
A		SHEET 19 of 20

REVISIONS			
SYM	DESCRIPTION	DATE	APPROVAL

B No Change

4.3.3.9 Power. - The valve assembly shall be tested with 28.0 vdc to check for conformance to the peak and steady stage current requirements which were approved by the procuring activity (See 3.3.12).

NOTE

All or parts of the functional tests may be combined into a continuous test procedure.

4.3.4 Preflight certification tests. - A preproduction sample shall be subjected to the preflight certification tests. The preproduction sample shall consist of valve assemblies which:

- (a) Have been made in accordance with the detail design which was approved by the procuring activity.
- (b) Have successfully completed the examinations of 4.3.2 and
- (c) Have successfully completed the acceptance tests of 4.3.5.

The number of valve assemblies in the preproduction sample shall be as specified by the procuring activity. Testing shall be performed in accordance with Table I. Disposition of the valve assemblies which have been subjected to the preflight certification tests shall be as specified by the procuring activity.

TABLE I - Preflight Certification Tests

Preflight Certification Test Paragraph	Number of Valve Assemblies to be Tested	Comments
4.3.4.1, 4.3.4.2, 4.3.4.3, 4.3.4.4, 4.3.4.7, and 4.3.4.8	Minimum of one	Testing required unless otherwise specified by the procuring activity.
4.3.4.6, 4.3.4.9, 4.3.4.10, 4.3.4.11 and 4.3.4.12, 4.3.4.15	Entire sample	Testing required
4.3.4.5 and 4.3.4.14	Minimum of one	Testing required
4.3.4.13	Minimum of one	Testing not required unless otherwise specified by the procuring activity.

REVISIONS

SYM	DESCRIPTION	DATE	APPROVAL
-----	-------------	------	----------

B                      No Change

4.3.4.1 Humidity.- The valve assembly shall be tested in accordance with method 507.1 of Standard MIL-STD-810A. After this the valve assembly shall be examined for failure, tested in accordance with 4.3.3 except 4.3.3.1 and 4.3.3.2, and checked for conformance to 3.6.

4.3.4.2 Salt fog.- The present valve assembly shall be tested in accordance with method 509.1 of Standard MIL-STD-810A. After this the valve assembly shall be examined for failure, tested in accordance with 4.3.3 except 4.3.3.1 and 4.3.3.2, and checked for conformance to 3.6.

4.3.4.3 Sand and dust.- The valve assembly shall be tested in accordance with method 510.1 of Standard MIL-STD-810A. After this the valve assembly shall be examined for failure, tested in accordance with 4.3.3 except 4.3.3.1 and 4.3.3.2, and checked for conformance to 3.6.

4.3.4.4 Fungus resistance.- The valve assembly shall be tested in accordance with method 508.1 Procedure I, of Standard MIL-STD-810A. After this the valve assembly shall be examined for failure, tested in accordance with 4.3.3 except 4.3.3.1 and 4.3.3.2 and checked for conformance to 3.6.

4.3.4.5 Full flow.- The valve assembly shall be tested in accordance with 4.3.3.6, 4.3.3.7, 4.3.3.8, and 4.3.3.9 with a liquid service media flow rate of 900 pounds per hour. The valve assembly shall also be tested to check for conformance to 3.3.1. Conditions other than specified may be used provided an effective simulation can be achieved. These conditions shall be documented in the test plan. The test results and the data showing conversion from test conditions to specified conditions shall be supplied in the test report.

4.3.4.6 Temperature.

4.3.4.6.1 Gaseous.- Gaseous temperature testing shall be as follows:

(a) High.- The valve assembly shall be tested in accordance with method 501.1 of Standard MIL-STD-810A except that the temperature shall be plus 165°F. While at plus 165°F the valve assembly shall also be tested to check for conformance to 3.3.13 by subjecting it to 10 of the following cycles:

- (1) Stabilize initially at plus 165°F
- (2) Engage for 5 continuous minutes with 30.0 vdc while maintaining a still air environmental temperature of plus 165°F.
- (3) Allow the valve assembly to return to the stabilization temperature of plus 165°F.

The valve assembly shall then be stabilized at the maximum operating temperature of plus 100°F and tested in accordance with 4.3.3 except 4.3.3.1, 4.3.3.2, 4.3.3.3.1, and 4.3.3.2(a)(2).

After this the valve assembly shall be tested in accordance with the low temperature portion.

CODE IDENT NO	DWG SIZE	20M42517
	A	SHEET 21 of 2

## REVISIONS

SYM	DESCRIPTION	DATE	APPROVAL
-----	-------------	------	----------

B

No Change

3-05-69

(b) Low. - The valve assembly shall be tested in accordance with method 502.1, Procedure I, of Standard MIL-STD-810A, except the temperature shall be minus 65°F. While stabilized at minus 65°F, the valve assembly shall be tested in accordance with 4.3.3 except 4.3.3.1, 4.3.3.2 and 4.3.3.3.2 (a) (2).

After gaseous temperature testing has been completed the valve assembly shall be returned to standard temperature, examined for failure and tested in accordance with 4.3.3 except 4.3.3.1 and 4.3.3.2.

4.3.4.6.2 Liquid. - Liquid service media testing shall be as follows:

(a) High. - The valve assembly shall be stabilized at plus 100°F. While at this temperature the valve assembly shall be tested in accordance with 4.3.3 except 4.3.3.1, 4.3.3.2, 4.3.3.3.1, and 4.3.3.3.2 (a) (1) using the liquid service media. After this the valve assembly shall be tested in accordance with the low temperature portion.

(b) Low. - The valve assembly shall be tested in accordance with method 502.1, Procedure I, of Standard MIL-STD-810A except the temperature shall be minus 65°F. While stabilized at minus 65°F, the valve assembly shall be tested in accordance with 4.3.3 except 4.3.3.1, 4.3.3.2, 4.3.3.3.1, and 4.3.3.3.2 (a) (1).

After liquid temperature testing has been completed the valve assembly shall be returned to standard temperature, examined for failure, and tested in accordance with 4.3.3 except 4.3.3.1 and 4.3.3.2.

4.3.4.7 Temperature cycle. - The valve assembly shall be subjected to 1500 cycles from plus 100 to minus 65 back to plus 100°F. During the cycles the valve assembly shall be filled with the liquid service media and all 3 ports pressurized to 20 psig. There shall be no flow. The temperature cycles shall be approximately sinusoidal. The duration of each cycle shall be 90 minutes maximum. After 300 and 900 cycles the valve assembly shall be tested in accordance with 4.3.3.3 while stabilized at plus 100°F. After 600 and 1200 cycles the valve assembly shall be tested in accordance with 4.3.3.3 while stabilized at minus 65°F. After 1500 cycles the valve assembly shall be returned to standard temperature, examined for failure, and tested in accordance with 4.3.3 except 4.3.3.1 and 4.3.3.2.

4.3.4.8 Compatibility. - The valve assembly shall be filled with the liquid service media and all 3 ports pressurized to 20 psig. The valve assembly shall remain under these conditions for 190 days. During this period the valve assembly shall be in a vacuum of  $1.5 \times 10^{-6}$  Torr or less. After 30, 60, 120, and 190 days the valve assembly shall be examined for failure and tested in accordance with 4.3.3 except 4.3.3.1 and 4.3.3.2.

4.3.4.9 Vibration. - The valve assembly shall be installed in a test setup which simulates the vehicle installation. The test setup shall be filled with the liquid service media and all 3 ports pressurized to 20 psig. Vibration testing shall be as follows:

CODE IDENT NO	DWG SIZE	20X42517
	A	SHEET 22 of 28

REVISIONS

SYM	DESCRIPTION	DATE	APPROVAL
-----	-------------	------	----------

B	Change.	3-05-69	
---	---------	---------	--

(a) Vehicle dynamics criteria.- The test setup shall be subjected to a sinusoidal scan at 3.0 octaves per minute along each of the 3 major axes. The levels and frequency ranges shall be as follows:

- (1) Flight axis
  - a. 5 to 23 Hz at 0.089 inch double amplitude displacement \*
  - b. 23 to 35 Hz at 2.4 G's peak \*
- (2) Lateral axes
  - a. 1.5 - 3.5 Hz at 0.5 inches double amplitude displacement \*
  - b. 3.5 to 20 Hz at 0.31 G's peak \*

(b) Sine evaluation criteria.- The test setup shall be subjected to a sinusoidal scan at 1.0 octave per minute along each of the 3 major axes. The level and frequency ranges shall be as follows:

- (1) 20 to 45 Hz at 0.023 inch double amplitude displacement \*
- (2) 45 to 2000 Hz at 2.3 G's peak \*

(c) High level random criteria.- The test setup shall be subjected to 1.0 minute of random vibration along each of the 3 major axes. The levels shall be as follows:

- (1) 20 to 46 Hz at plus 6.0 db per octave \*
- (2) 46 to 100 Hz at 0.143 g<sup>2</sup> per Hz \*
- (3) 100 to 210 Hz at minus 9.0 db per octave \*
- (4) 210 to 750 Hz at 0.015 g<sup>2</sup> per Hz \*
- (5) 750 to 1155 Hz at minus 12 db per octave \*
- (6) 1155 to 2000 Hz at 0.00262 g<sup>2</sup> per Hz \*

(d) Low level random criteria.- The test setup shall be subjected to 4.0 minutes of random vibration along each of the 3 major axes. The levels shall be as follows:

- (1) 20 to 46 Hz at plus 6.0 db per octave \*
- (2) 46 to 100 Hz at 0.0644 g<sup>2</sup> per Hz \*
- (3) 100 to 210 Hz at minus 9 db per octave \*
- (4) 210 to 750 Hz at 0.0067 g<sup>2</sup> per Hz \*
- (5) 750 to 1155 Hz at minus 12 db per octave \*
- (6) 1155 to 2000 Hz at 0.00118 g<sup>2</sup> per Hz \*

CODE	DWG	20M42517
IDENT NO	SIZE	
	A	SHEET 23 of 23



## REVISIONS

SYM	DESCRIPTION	DATE	APPROVAL
-----	-------------	------	----------

C

Change

11-13-69

At the conclusion of all vibration the valve assembly shall be examined for failure, and tested in accordance with 4.3.3.

4.3.4.10 Life Cycle.- The valve assembly shall be subjected to 1000 cycles of operation. Each cycle shall consist of moving the valve assembly from the primary to the secondary back to the primary position or vice versa. The cycling shall be performed at 28.0 vdc. During all the cycles the position switches shall be checked for proper operation and shall be loaded with a resistive load of 3.0 amperes at 28.0 vdc when the contacts are closed. The duration of the pulses and the rate of cycling shall be included in the test plan (See 4.3.1.2.1). After 150, 300, 500 and 750 cycles the valve assembly shall be tested in accordance with 4.3.3 except 4.3.3.1, 4.3.3.2, 4.3.3.3.1 and 4.3.3.5. After 1000 cycles the valve assembly shall be examined for failure and tested in accordance with 4.3.3.

4.3.4.11 Acoustical Noise.- The valve assembly shall be installed in a test setup which simulates the vehicle installation. The test setup shall be filled with liquid service media and all 3 ports pressurized to 20 psig. The valve assembly shall then be tested in accordance with paragraph 5.2.5.2 of Drawing 50M02408B using the levels of Appendix E of the same Drawing. At the conclusion of acoustic noise testing the valve assembly shall be examined for failure and tested in accordance with 4.3.3.

4.3.4.12 Transient pulses.- The valve assembly shall be tested in accordance with 4.3.3.7, 4.3.3.8 and 4.3.3.9 with the pulses present to check for conformance to 3.3.17.

4.3.4.13 Collapse pressure.- The valve assembly shall be slowly, externally pressurized to 19 psig. This pressure shall be held for 3 minutes before reducing to zero. The valve assembly shall be checked for conformance to 3.3.6.

NOTE

The burst pressure test shall be the last performed

4.3.4.14 Burst pressure.- Simultaneously the 3 ports of the valve assembly shall be slowly pressurized to 125 psig. This pressure shall be held for 3 minutes. The pressure shall then be slowly increased until the valve assembly ruptures. The valve assembly shall be checked for conformance to 3.3.4.

4.3.4.15 Coil Transient Voltage.- With the valve stabilized at room temperature, \* the rated operating voltage shall be applied to the coil terminals. Before the valve has been energized for 10 seconds, the valve shall be de-energized and the coil transient voltage measured with an oscilloscope. The maximum allowable peak transient voltage shall not exceed a value equal to 50 percent above the rated coil voltage. The valve coil shall be connected directly to the power supply. The use of resistors, capacitors, inductors, or semi-conductor devices in series or parallel with the coil not inherent in the properly set up test circuit is forbidden. The transient voltage shall be measured a minimum of three times and the largest transient value recorded as the actual valve.

NOTE

It is recommended that the device used to de-energize the valve under test be a mercury switch or mercury wetted relay contact. When a mercury relay is used as the switching device, its coil should be operated

CODE	DWG	
IDENTNO	SIZE	20M42518
	A	SHEET 24 of 28

REVISIONS

SYM	DESCRIPTION	DATE	APPROVAL
C	Change	11-13-69	

from a separate source, isolated from the source used to operate the valve coil under test. The oscilloscope used should have a rise time equal to or less the 0.2 microsecond. Photographs of the oscilloscope traces are helpful in ascertaining precise voltage measurements of the transients, but are not required. In order to observe the maximum vertical excursion of the transient voltage, horizontal sweep times of from 100 microseconds per centimeter (CM) to 20 microseconds per cm may be necessary.

4.3.5 Acceptance tests.- All valve assemblies which are intended for acceptance by the procuring activity shall be subjected to the acceptance tests. Valve assemblies cannot be accepted until they have successfully completed the examinations of 4.3.2 prior to being subjected to these tests. The acceptance tests shall be performed using only gaseous test media. The acceptance tests shall be as follows in the order listed:

- (a) Proof pressure - same as 4.3.3.1
- (b) Leakage - same as 4.3.3.3.1 and the gaseous portion of 4.3.3.3.1

NOTE

The remainder of the functional tests, 4.3.3.2 and 4.3.3.4 through 4.3.3.9 may be performed prior to the acceptance vibration test upon the approval of the procuring activity.

(c) Acceptance vibration.- The valve assembly shall be installed in a test setup which simulates the vehicle installation. All three ports of the valve assembly shall be pneumatically pressurized to 20 psig. The test setup shall be subjected to 1.0 minute of random vibration along the axis normal to the mounting plane. The levels shall be as follows:

- (1) 20 to 46 Hz at +6.0 db per octave \*
- (2) 46 to 100 Hz at 0.0357 g<sup>2</sup> per Hz \*
- (3) 100 to 210 Hz at -9.0 db per octave \*
- (4) 210 to 750 Hz at 0.00375 g<sup>2</sup> per Hz \*
- (5) 750 to 1155 Hz at -12.0 db per octave \*
- (6) 1155 to 2000 Hz at 0.000655 g<sup>2</sup> per Hz \*

(d) Functional tests. - same as 4.3.3

(e) Coil transient voltage.- same as 4.3.4.15 \*

4.3.6 Quality assurance sample tests.- A quality assurance sample shall be selected from production valve assemblies when so specified by the purchasing documentation. The quality assurance sample shall consist of valve assemblies which:

(a) Have been made in accordance with the detail design which was approved by the procuring activity.

(b) Have been selected at random from the valve assemblies which have been accepted by the procuring activity.

CODE IDENT NO	DWG SIZE	20M42518
	A	SHEET 28 of 28

REVISIONS

SYM	DESCRIPTION	DATE	APPROVAL
C	Change	11-13-69	

TABLE II - Quality Assurance Sample Test

Test Paragraph	Number of Valve Assemblies to be tested	Comments
4.3.4.1, 4.3.4.2, 4.3.4.3, 4.3.4.4, 4.3.4.5, 4.3.4.7, 4.3.4.8 and 4.3.4.13	Minimum of one	Testing not required unless otherwise specified by the procuring activity.
4.3.4.6, 4.3.4.9, 4.3.4.10, 4.3.4.11, 4.3.4.12 and 4.3.4.15	Entire sample	Testing Required
4.3.4.14	Minimum of one	Testing required

5. PREPARATION FOR DELIVERY

5.1 Preservation and packing shall be as specified by the applicable cleaning specification unless otherwise specified by the procuring activity. Packing and marking may be equivalent to the supplier's best commercial practice provided that this practice will be sufficient to protect the valve assemblies against damage and contamination during shipment. The supplier shall be held responsible for any damage to or contamination of the valve assemblies due to faulty packing. If the valve assemblies fail to meet the requirements of this specification because of such damage or contamination, an acceptable replacement shall be furnished by the supplier at no cost to the procuring activity. Exterior containers shall conform to the Uniform Freight Classification Rules or the National Motor Freight Classification Rules and to applicable container specifications.

CODE IDENT NO	DWG SIZE	20M42517
	A	SHEET 26 of 28

REVISIONS

SYM	DESCRIPTION	DATE	APPROVAL
-----	-------------	------	----------

B

No Change SYMIA 87+ OL DEERED TO +28 VOLTS AMPLITUDE IN VOLTS REFERENCED TO COMMON

SUSCEPTIBILITY TEST LIMITS



FIGURE 3. TRANSIENT PULSES

CODE IDENT NO	DWG SIZE	20X42517
	A	SHEET 27 OF 28

REVISIONS			
SYM	DESCRIPTION	DATE	APPROVAL

B No Change

- |    |   |  |
|----|---|--|
| A. | - | Port A Open (Closed Contacts)                        |
| B. | - | Port A Open (Open Contacts)                          |
| E. | - | Common Port A Contacts                               |
| G. | - | Spare  |
| C. | - | Port B Open (Closed Contacts)                        |
| D. | - | Port B Open (Open Contacts)                          |
| F. | - | Common Port B Contacts                               |
| J. | - | Minus 28 vdc Pulse, Port A Open (Primary Position)   |
| K. | - | Minus 28 vdc Pulse, Port B Open (Secondary Position) |
| L. | - | Plus 28 vdc Pulse, Port A Open (Primary Position)    |
| M. | - | Plus 28 vdc Pulse, Port B Open (Secondary Position)  |
| H. | - | Case Ground  |

FIGURE 4. Pin Functions

CODE IDENT NO	DWG SIZE	20X42517
	A	SHEET 28 of 28

## EQUIPMENT LIST

Type Equipment	Manufacturer	Model #	Range	Accuracy	Tag #	Date Last Calibration
Oscilloscope	Tektronix	RM41A	---	---	AF715347	12/69
Plug-In	Tektronix	CA	.1-20 V/CM	---	AF715347-1	12/69
Ammeter	Simpson	1702	0-1.5A	.5% of F.S.	X28245	12/69
Voltmeter, Plug-In	Hickok	DP 100	1 V to	+1% F.S.	STE 001 014	3/70
Frame	Hickok	DMS 3200	1000 Volts	+1%	STE 001 013	3/70
Megger	Freed Xfmr Co.	1620 C	0-1000 Volts	---	SI759	8/70
Resist., Plug-In	Hickok	DP 170	Milliohms/Megohm	+2%	SC 1327	12/70
Leak Checker	Veeco	MS 90AB	3.4x10 <sup>-8</sup>	10%	S-2352	8/70
Leak Standard	Veeco	SC-4	Sec, HE/Sec	---	C-1384	6/70
Pressure Gage	Marsh Inst. Co.	AA	0-150 psig	3%	C1486	12/70
Pressure Gage	Ashcroft Co.	---	0-200 psig	3%	X 23965	8/70
Pipette	Fisher	10 ML	10 ML	≤5%	C 1571	12/69
Diff. Press. Gag.	Barton Inst.	---	0-2 psid	+2%	C1865	1/70
Power Supply	Trygon	SHR40-1.5	40 V - 1.5 Amp	Actual Reading Set with Volt-meter or Oscilloscope.	S 2513-2	ANC*
Power Supply	Tektronix	160A	---	Actual Reading	S 0149	2/70
Pulse Generator	Tektronix	161	0-100 MS	Set & Measured	X24058	2/70
Waveform Gen.	Tektronix	162	---	w/Oscilloscope	X24059	2/70
Pulse Generator	Velonex	380-13	2.5-7.5 micro-seconds	Actual Reading Set & Measured w/Oscilloscope	S3535	ANC*
Temp. Meter	API	429 =	-75°F to	+2%	MS 22002	8/70
"	"	82927	+225°F	---	MS 22001	8/70
"	"	---	---	---	MS 22004	8/70
Temp. Controller	Cole-Parmer	2158	-100°F -	+50°F	MS 22006	8/70
"	"	2158	+250°F	---	MS 22007	8/70
Graph Recorder	Beckman	Type R	10-500 MV/CM	+2%	S 2487-1 then S2487-22	8/70
Flow Meter	Fisher-Porter	10A2700	0-7.5 GPM	+1% F.S.	S 3586	10/70
Camera	Polaroid	---	---	---	No CAL	---
Ohmmeter	Simpson	260	0-2K	+3%	X15162	10/70
Pump	Aurora	D4	0-4 GPM	---	No CAL	---

\*Ancillary Equipment

## EQUIPMENT LIST

2.

Type Equipment	Manufacturer	Model #	Range	Accuracy	Tag #	Date Last Calibration
Thermal Chamber (Hot)	Tenney	---	-25°F- +225°F	---	51904	3/70
Thermal Chamber (Cold)	Tenney	---	-100°F- +300°F	---	S1969	12/70
Tank Pressure Indicator	Mathieson	22025-1	0-3000	---	No Cal	---
Regulator Valve	Mathieson	---	0-400 psi	---	No Cal	---
Hand Pump	Enerpac	462	0-10,000	---	No Cal	---
Vibration System I Exciter	MB Elecs.	G25HB C-25-HB-2	5-2000 CPS		AF 89 AF 308	
Console Amplifier	"	UDAGC-RA-803	3500 lb.	± 5%	AF 3518	10/70
Accelerometer	Endevco	MB T66-13 GR-12			AF 290	

Test Data Sheet  
Pulse Operated Flow Diverter Valve  
Specification 20M42517

Serial No. 007 Date: 6-4-70  
 Mech. Tech. REO Test Eng. RMR  
 Elect. Tech.        Q. C. Eng. HPG  
 TECH.

5.1 Pre-Test Examination

Discrepancies/Comments: \_\_\_\_\_  
SEE DAP # ANCO 007

5.1.1 Identification

Discrepancies/Comments: \_\_\_\_\_  
NONE

5.1.2 Workmanship

Discrepancies/Comments: \_\_\_\_\_  
NONE

5.1.3 Cleaning

Discrepancies/Comments: \_\_\_\_\_  
NONE

5.3.1 PROOF PRESSURE

5 MIN @ 75 ± 7.5 PSIG	ALLOWABLE	ACTUAL		O.K.	REJECT	INITIAL
	NO DEFORMATION OR PERMANENT SET	TIME 7 MIN	PASSES 70-65			
				✓		RMR 6-5-70

COMMENTS: TEST > 5 MIN. CYCLES = 8 TOTAL  
 DATE: 6-5-70

5.3.2 LEAKAGE EXTERNAL

100% HELIUM @ 50 PSIG INTERNAL PRESSURE	ALLOWABLE	ACTUAL	O.K.	REJECT	INITIAL
	$1.6 \times 10^{-6}$ CC/S	$.75 \times 10^{-7}$	✓		RMR 6-5-70

COMMENTS STD LK =  $1.25 \times 10^{-7}$  STD LK READING = 10, SCALE LEAKING = 6.0  
 DATE 6-5-70 CYCLES = 8 TOTAL



Test Data Sheet  
Pulse Operated Flow Diverter Valve  
Specification 20M42517

Serial No. 008 Date: 6-8-70  
 Mech. Tech. REO Test Eng. RMR  
 Elect. Tech. \_\_\_\_\_ Q. C. Eng. HPG  
 TECH.

5.1 Pre-Test Examination

Discrepancies/Comments: \_\_\_\_\_  
SEE DAP # AV30-003

5.1.1 Identification

Discrepancies/Comments: \_\_\_\_\_  
NONE

5.1.2 Workmanship

Discrepancies/Comments: \_\_\_\_\_  
NONE

5.1.3 Cleaning

Discrepancies/Comments: \_\_\_\_\_  
NONE

5.3.1 PROOF PRESSURE

5 MIN @ 75 ± 9.5 PSIG	ALLOWABLE NO DEFORMATION OR TECH. SET	ACTUAL		O.K.	REJECT	INITIAL
		TIME	PRESS			
		5 1/2 MIN	75.0 PSIG	✓		<i>[Signature]</i>

COMMENTS TEST 5 MIN<sup>T</sup> CYCLES = 10  
 DATE 6-8-70

5.3.2 LEAKAGE EXTERNAL

100% HE @ 50 PSIG INTERNAL PRESSURE	ALLOWABLE	ACTUAL	O.K.	REJECT	INITIAL
	$1.6 \times 10^{-6}$ SCES	$1.46 \times 10^{-7}$ SCES	✓		<i>[Signature]</i>

COMMENTS STD LE =  $1.25 \times 10^{-7}$  SCES, STD LE READING = 18, ACTUAL - SCALE  
 DATE 6-8-70 READING = 13  
 CYCLES = 10 TOTAL

**Test Data Sheet**  
**Pulse Operated Flow Diverter Valve**  
**Specification 20M42517**

Serial No. 007  
 Mech. Tech. REO  
 Elect. Tech.           

Test Eng. RMR  
 Q. C. Tech. HPL

**5.3.3 Leakage Internal**

Port A Methanol/Water	Allowable	Actual			O. K.	Reject	Initial
		1	2	3			
5.0 ± .5 psig ΔP	0.20 sccs	0.0	0.0	0.0	✓		HPL
10.0 ± 1.0 psig ΔP	0.20 sccs	0.0	0.0	0.0	✓		HPL
20.0 ± 2.0 psig ΔP	0.20 sccs	0.0	0.0	0.0	✓		HPL

Date 6-8-70

Port B Methanol/Water	Allowable	Actual			O. K.	Reject	Initial
		1	2	3			
5.0 ± .5 psig ΔP	0.20 sccs	0.0	0.0	0.0	✓		HPL
10.0 ± 1.0 psig ΔP	0.20 sccs	0.0	0.0	0.0	✓		HPL
20.0 ± 2.0 psig ΔP	0.20 sccs	0.017	0.008	0.017	✓		HPL

Photo Taken No

Date 6-8-70

Comments: CYCLES = 18 TOTAL

**5.3.4 Acceptance Vibration**

Random - Spectral Density per 5.3.4 Internal Pressure	Allowable	Actual	O. K.	Reject	Initial
20 ± 2.0 psig, GN2	Overall ±10% Density = +100% - 30%	> 100% AT 1500 CPS	SEE COMMENTS		RMR

Photo Taken No

Date 6-8-70

Comments: CYCLE = 24 TOTAL  
OVER TEST AT 1500 CPS

PRESSURE LEVEL CHECKED AFTER VIBRATION. NO LOSS OF PRESS. 6Y. DUE TO VIBRATION.



6-9-70

Test Data Sheet  
Pulse Operated Flow Diverter Valve  
Specification 20M42517

Serial No. 008  
Mech. Tech. PEO  
Elect. Tech. \_\_\_\_\_

Test Eng. RMR  
Q. C. Tech. HPG

5.3.3 Leakage Internal

Port A Methanol/Water	Allowable	Actual			O. K.	Reject	Initial
		1	2	3			
5.0 ± .5 psig ΔP	0.20 sccs	0.0	0.0	0.0	✓		H. Hall
10.0 ± 1.0 psig ΔP	0.20 sccs	0.0	0.0	0.0	✓		H. Hall
20.0 ± 2.0 psig ΔP	0.20 sccs	0.0	0.0	0.0	✓		H. Hall

Date 6-8-70

Port B Methanol/Water	Allowable	Actual			O. K.	Reject	Initial
		1	2	3			
5.0 ± .5 psig ΔP	0.20 sccs	0.0	0.0	0.0	✓		H. Hall
10.0 ± 1.0 psig ΔP	0.20 sccs	0.0	0.0	0.0	✓		H. Hall
20.0 ± 2.0 psig ΔP	0.20 sccs	0.0	0.0	0.0	✓		H. Hall

Photo Taken No  
Date 6-8-70

Comments: CYCLES = 18 TOTAL

5.3.4 Acceptance Vibration

Random - Spectral Density per 5.3.4 Internal Pressure 20 ± 2.0 psig, GN 2	Allowable	Actual	O. K.	Reject	Initial
	Overall ± 10% Density = +100% - 30%	> 100% AT 1500 CPS	SEE COMMENTS		VES

Photo Taken No  
Date 6-8-70

Comments: CYCLES = 24 TOTAL  
OVERTEST AT 1500 CPS

PRESSURE LEVEL CHECKED AFTER VIBRATION. NO LOSS OF PRESS. DUE TO VIBRATION. VALVE AGAIN CHARGED TO 20 PSIG AND VENTED INTO A PRESSURE GAGE. FINAL PRESSURE (15.5 PSIG) SAME AS POST VIBRATION PRESSURE LEVEL

TWO	CUSTOMER	
ITEM	AXIS	REF.
SINE	SYST. NO.	SHAKER
RANDOM		DATE
ANALYSIS		
OPERATOR		

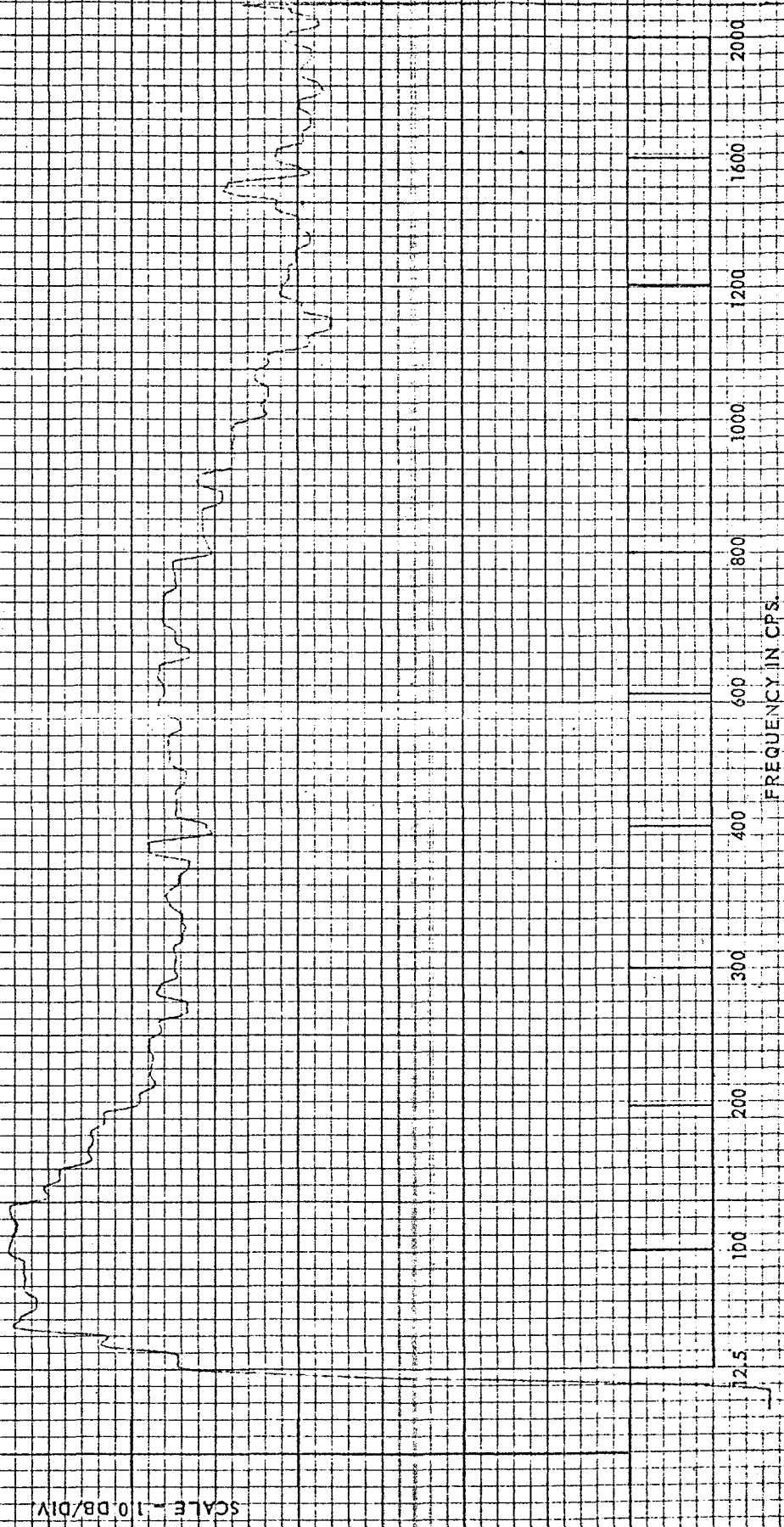

SCALE - 10 DB/DIV

Test Data Sheet  
Pulse Operated Flow Diverter Valve  
Specification 20M42517

Serial No. 007  
Mech. Tech. REO  
Elect. Tech. \_\_\_\_\_

Test Eng. RMR  
Q. C. Tech. HPG

5.3.5 Vacuum Internal

	Allowable	Actual	O. K.	Reject	Initial
1. Internal Pressure	$1.94 \times 10^{-4}$ torr min.	$2 \times 10^{-5}$	✓		<i>HPG</i>
2. External Pressure	14.7 psia	14.7 psia			<i>HPG</i>
3. Duration	5 minutes min.	5.5 MIN	✓		<i>HPG</i>
4. Visual Examination	no deformation or permanent set	NO DEFORMATION	✓		✓

Photo Taken No  
Date 6-9-70

Comments: CYCLES = 31 TOTAL

AD 16  
378  
6-9-70

5.3.6 Proof Pressure, After Acceptance Vibration

5 min. @ 75 ± 7.5 psig	Allowable no deformation or permanent set	Actual		O. K.	Reject	Initial
		Time	Press			
		5 MIN 2.0 SEC	150 PSIG	✓		<i>HPG</i>

Date 6-9-70

Comments: CYCLES = 34 TOTAL

AD 16  
378  
6-9-70

5.3.7 Leakage External (Gaseous), After Acceptance Vibration

100% Helium @ 50 psig internal pressure	Allowable	Actual	O. K.	Reject	Initial
	$1.6 \times 10^{-6}$ sec S	$2.08 \times 10^{-7}$ sec S	SEE COMMENTS		<i>HPG</i>

Date 6-9-70 (RMR)

Comments: STD. LK =  $1.25 \times 10^{-7}$  SECS. STD. LK IF READING > 42, ACTUAL SCALE  
CYCLES = 39 TOTAL READING = 7.0

AD 16  
378  
6-9-70

Test Data Sheet  
Pulse Operated Flow Diverter Valve  
Specification 20M42517

Serial No. 008 Test Eng. RMR  
Mech. Tech. PEO Q. C. Tech. HPG  
Elect. Tech. —

5.3.5 Vacuum Internal

	Allowable	Actual	O. K.	Reject	Initial
1. Internal Pressure	$1.94 \times 10^{-4}$ torr min.	$2.1 \times 10^{-5}$	✓		HPEY
2. External Pressure	14.7 psia	14.87			HPEY
3. Duration	5 minutes min.	5.5 MIN	✓		HPEY
4. Visual Examination	no deformation or permanent set	NO DEFORMATION	✓		

Photo Taken No  
Date 6-9-70

Comments: CYCLES, TOTAL = 28



6-9-70

5.3.6 Proof Pressure, After Acceptance Vibration

5 min. @ 75 ± 7.5 psig	Allowable no deformation or permanent set	Actual		O. K.	Reject	Initial
		Time	Press			
		5 MIN 20 SEC	750 PSIG	✓		HPEY

Date 6-9-70

Comments: CYCLES = 32 TOTAL

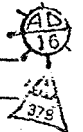

6-9-70

5.3.7 Leakage External (Gaseous), After Acceptance Vibration

100% Helium @ 50 psig internal pressure	Allowable	Actual	O. K.	Reject	Initial
	$16 \times 10^{-6}$ SCCS	$1.8 \times 10^{-7}$ SCCS	✓		HPEY

Date 6-9-70

Comments: STD LK =  $1.25 \times 10^{-7}$  SCCS. STD LK. READING =  $1.25 \times 10^{-7}$  ACTUAL SCALE READING = 1.2

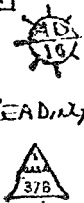

6-9-70

CYCLES = 31 TOTAL

Test Data Sheet

Pulse Operated Flow Diverter Valve  
Specification 20M42517

Serial No. 007  
Mech. Tech. REO  
Elect. Tech. REO

Test Eng. RMR  
Q. C. Tech. HPG

5.3.8 Leakage Internal (Gaseous), After Acceptance Vibration

Port A	Allowable	Actual			O. K.	Reject	Initial
		1	2	3			
5.0 + .5 psig ΔP	0.20 sccs	0.0	0.0	0.0	✓		HPG
10.0 + 1.0 psig ΔP	0.20 sccs	0.0	0.0	0.0	✓		HPG
20.0 + 2.0 psig ΔP	0.20 sccs	0.0	0.0	0.0	✓		HPG

Date 6-9-70

Port B	Allowable	Actual			O. K.	Reject	Initial
		1	2	3			
5.0 + .5 psig ΔP	0.20 sccs	0.0	0.0	0.008	✓		HPG
10.0 + 1.0 psig ΔP	0.20 sccs	0.0	0.0	0.0	✓		HPG
20.0 + 2.0 psig ΔP	0.20 sccs	0.017	0.017	0.008	✓		HPG

Date 6-9-70

Comments: CYCLES = 45 TOTAL

5.3.9 Circuit Resistance

5.3.9.1

Port "A" Open Pins	Limit	Actual		
		1	2	3
From To				
A E	0.5 ohms max.	0.1	0.1	0.1
D F	0.5 ohms max.	0.1	0.1	0.1
H Case	0.5 ohms max.	0.2	0.1	0.1
L J	25-29 OHMS	27.3	27.9	27.9
B E	Open Circuit	OPEN	OPEN	OPEN
C F	Open Circuit	OPEN	OPEN	OPEN

Accept ✓  
Reject \_\_\_\_\_

Initial AMG  
Date 6-10-70

Test Data Sheet  
Pulse Operated Flow Diverter Valve  
Specification 20M42517

Serial No. 008  
Mech. Tech. KEO  
Elect. Tech. KEO

Test Eng. RMR  
Q. C. Eng. HPG  
TECH.

5.3.8 Leakage Internal (Gaseous), After Acceptance Vibration

Port A	Allowable	Actual			O. K.	Reject	Initial
		1	2	3			
5.0 + .5 psig ΔP	0.20 sccs	0.0	0.0	0.0	✓		Weyl
10.0 + 1.0 psig ΔP	0.20 sccs	0.0	0.0	0.0	✓		Weyl
20.0 + 2.0 psig ΔP	0.20 sccs	0.0	0.0	0.0	✓		Weyl

Date \_\_\_\_\_

Port B	Allowable	Actual			O. K.	Reject	Initial
		1	2	3			
5.0 + .5 psig ΔP	0.20 sccs	0.0	0.0	0.0	✓		Weyl
10.0 + 1.0 psig ΔP	0.20 sccs	0.0	0.0	0.0	✓		Weyl
20.0 + 2.0 psig ΔP	0.20 sccs	0.0	0.0	0.0	✓		Weyl

Date 6-9-70

Comments: CYCLE = 53 TOTAL

5.3.9 Circuit Resistance

5.3.9.1

Port "A" Open Pins		Limit	Actual		
From	To		1	2	3
A	E	0.5 ohms max.	0.1	0.1	0.1
D	F	0.5 ohms max.	0.1	0.1	0.1
H	Case	0.5 ohms max.	0.1	0.1	0.1
L	J	25-29 ohms	25.4	25.5	25.4
B	E	Open Circuit	OPEN	OPEN	OPEN
C	F	Open Circuit	OPEN	OPEN	OPEN

Accept ✓  
Reject \_\_\_\_\_

Initial Weyl  
Date 6/10/70



Test Data Sheet  
Pulse Operated Flow Diverter Valve  
Specification 20M42517

Serial No. 607 Test Eng. RMR  
Mech. Tech. RMR Q. C. Eng. ALRT  
Elect. Tech. RMR TEW

5.3.9.2

Port "B" Open Pins		Limit	Actual		
From	To		1	2	3
A	E	Open Circuit	OPEN	OPEN	OPEN
D	F	Open Circuit	OPEN	OPEN	OPEN
H	Case	0.5 ohms max.	0.2	0.1	0.1
M	K	25-29 ohms	27.9	27.7	27.9
B	E	0.5 ohms max.	0.1	0.1	0.1
C	F	0.5 ohms max.	0.1	0.1	0.1

ASATA 37B 6-10-70



Accept  Initial ALRT  
Reject \_\_\_\_\_ Date 6-9-70  
Photo Taken NO

Comments: TOTAL CYCLES = 61

5.3.10.1 Insulation Resistance

500 Volts D. C. Pins		Limit	Actual
From	To		
A	C	50 meg. ohms min. ✓	>200 KMΩ
A	D	50 meg. ohms min. ✓	>200 KMΩ
A	F	50 meg. ohms min. ✓	>200 KMΩ
A	H	50 meg. ohms min. -----	200 KMΩ
A	J	50 meg. ohms min. ✓	>200 KMΩ
A	L	50 meg. ohms min. ✓	>200 KMΩ
A	M	50 meg. ohms min. ✓	>200 KMΩ
A	Case	50 meg. ohms min. -----	190 KMΩ
B	C	50 meg. ohms min. ✓	>200 KMΩ
B	D	50 meg. ohms min. ✓	↑ ↓
B	F	50 meg. ohms min. ✓	
B	A	50 meg. ohms min. ✓	
B	J	50 meg. ohms min. ✓	
B	J	50 meg. ohms min. ✓	

6-10-70



Test Data Sheet  
Pulse Operated Flow Diverter Valve  
Specification 20M42517

Serial No. 008 Test Eng. RMR  
Mech. Tech. RMC Q. C. Eng. ALRT  
Elect. Tech. RMC TECH

5.3.9.2

Port "B" Open Pins		Limit	Actual		
From	To		1	2	3
A	E	Open Circuit	OPEN	OPEN	OPEN
D	F	Open Circuit	OPEN	OPEN	OPEN
H	Case	0.5 ohms max.	0.2	0.1	0.1
M	K	25-29 ohms	25.5	25.5	25.5
B	E	0.5 ohms max.	0.1	0.1	0.1
C	F	0.5 ohms max.	0.1	0.1	0.1

 6-10-70

Accept  Initial RMR  
Reject  Date 6/10/70  
Photo Taken NO

Comments: CYCLES = 59 TOTAL

5.3.10.1 Insulation Resistance

500 Volts D. C. Pins		Limit	Actual
From	To		
A	C	50 meg. ohms min. ✓	200 KMΩ
A	D	50 meg. ohms min. ✓	200 KMΩ
A	F	50 meg. ohms min.	200 KMΩ
A	H	50 meg. ohms min. —	120 KMΩ
A	J	50 meg. ohms min.	> 200 KMΩ
A	L	50 meg. ohms min.	> 200 KMΩ
A	M	50 meg. ohms min.	> 200 KMΩ
A	Case	50 meg. ohms min.	120 KMΩ
B	C	50 meg. ohms min.	> 200 KMΩ
B	D	50 meg. ohms min.	> 200 KMΩ
B	F	50 meg. ohms min.	> 200 KMΩ
B	A	50 meg. ohms min.	> 200 KMΩ
B	J	50 meg. ohms min.	> 200 KMΩ

 6-10-70

Test Data Sheet  
Pulse Operated Flow Diverter Valve  
Specification 20M42517

Serial No. 007 Test Eng. RMR  
Mech. Tech. LMR Q. C. Eng. ADT  
Elect. Tech. RMR TSM

Continued

From	To	Limit	Actual
B	K	50 meg. ohms min. ✓	>200 KM-2
B	L	50 meg. ohms min. ✓	>200 KM-2
B	M	50 meg. ohms min. ✓	>200 KM-2
B	Case	50 meg. ohms min. ---	150 KM-2
C	E	50 meg. ohms min. ✓	>200 KM-2
C	H	50 meg. ohms min. ---	150 KM-2
C	J	50 meg. ohms min. ✓	>200 KM-2
C	K	50 meg. ohms min. ✓	↕
C	L	50 meg. ohms min. ✓	↕
C	M	50 meg. ohms min. ✓	>200 KM-2
C	Case	50 meg. ohms min. ---	150 KM-2
D	E	50 meg. ohms min. ✓	>200 KM-2
D	H	50 meg. ohms min. ---	170 KM-2
D	J	50 meg. ohms min. ✓	>200 KM-2
D	K	50 meg. ohms min. ✓	↕
D	L	50 meg. ohms min. ✓	↕
D	M	50 meg. ohms min. ✓	>200 KM-2
D	Case	50 meg. ohms min. ---	170 KM-2
E	F	50 meg. ohms min. ✓	>200 KM-2
E	H	50 meg. ohms min. ---	150 KM-2
E	J	50 meg. ohms min. ✓	>200 KM-2
E	K	50 meg. ohms min. ✓	↕
E	L	50 meg. ohms min. ✓	↕
E	M	50 meg. ohms min. ✓	>200 KM-2
E	Case	50 meg. ohms min. ---	150 KM-2
F	H	50 meg. ohms min. ---	150 KM-2
F	J	50 meg. ohms min. ✓	>200 KM-2
F	K	50 meg. ohms min. ✓	↕
F	L	50 meg. ohms min. ✓	↕
F	M	50 meg. ohms min. ✓	>200 KM-2
F	Case	50 meg. ohms min. ---	150 KM-2
G	A	50 meg. ohms min. ✓	>200 KM-2
G	B	50 meg. ohms min. ✓	↕
G	C	50 meg. ohms min. ✓	↕
G	D	50 meg. ohms min. ✓	↕
G	E	50 meg. ohms min. ✓	>200 KM-2

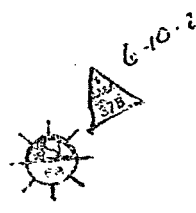

Test Data Sheet  
Pulse Operated Flow Diverter Valve  
Specification 20M42517

Serial No. 008  
Mech. Tech. RMR  
Elect. Tech. RMR

Test Eng. RMR  
Q. C. Eng. MLT  
FELM

Continued

From	To	Limit	Actual
B	K	50 meg. ohms min.	> 200 KM $\Omega$
B	L	50 meg. ohms min.	> 200 KM $\Omega$
B	M	50 meg. ohms min.	> 200 KM $\Omega$
B	Case	50 meg. ohms min.	150 KM $\Omega$
C	E	50 meg. ohms min.	> 200 KM $\Omega$
C	H	50 meg. ohms min.	150 KM $\Omega$
C	J	50 meg. ohms min.	> 200 KM $\Omega$
C	K	50 meg. ohms min.	> 200 KM $\Omega$
C	L	50 meg. ohms min.	> 200 KM $\Omega$
C	M	50 meg. ohms min.	200 KM $\Omega$
C	Case	50 meg. ohms min.	150 KM $\Omega$
D	E	50 meg. ohms min.	> 200 KM $\Omega$
D	H	50 meg. ohms min.	190 KM $\Omega$
D	J	50 meg. ohms min.	> 200 KM $\Omega$
D	K	50 meg. ohms min.	> 200 KM $\Omega$
D	L	50 meg. ohms min.	> 200 KM $\Omega$
D	M	50 meg. ohms min.	> 200 KM $\Omega$
D	Case	50 meg. ohms min.	190 KM $\Omega$
E	F	50 meg. ohms min.	> 200 KM $\Omega$
E	H	50 meg. ohms min.	150 KM $\Omega$
E	J	50 meg. ohms min.	> 200 KM $\Omega$
E	K	50 meg. ohms min.	> 200 KM $\Omega$
E	L	50 meg. ohms min.	> 200 KM $\Omega$
E	M	50 meg. ohms min.	> 200 KM $\Omega$
E	Case	50 meg. ohms min.	150 KM $\Omega$
F	H	50 meg. ohms min.	150 KM $\Omega$
F	J	50 meg. ohms min.	200 KM $\Omega$
F	K	50 meg. ohms min.	200 KM $\Omega$
F	L	50 meg. ohms min.	200 KM $\Omega$
F	M	50 meg. ohms min.	200 KM $\Omega$
F	Case	50 meg. ohms min.	150 KM $\Omega$
G	A	50 meg. ohms min.	> 200 KM $\Omega$
G	B	50 meg. ohms min.	> 200 KM $\Omega$
G	C	50 meg. ohms min.	> 200 KM $\Omega$
G	D	50 meg. ohms min.	> 200 KM $\Omega$
G	E	50 meg. ohms min.	> 200 KM $\Omega$

6-10-73



Test Data Sheet  
Pulse Operated Flow Diverter Valve  
Specification 20M42517

Serial No. 0017  
Mech. Tech. RMP  
Elect. Tech. RMP

Test Eng. RMP  
Q. C. Eng. ALST  
TECH

Continued

From	To	Limit	Actual
G	F	50 meg. ohms min. ✓	7200 KMΩ
G	H	50 meg. ohms min. ---	190 KMΩ
G	J	50 meg. ohms min. ✓	>200 KMΩ
G	K	50 meg. ohms min. ✓	>200 KMΩ
G	L	50 meg. ohms min. ✓	>200 KMΩ
G	M	50 meg. ohms min. ✓	>200 KMΩ
H	J	50 meg. ohms min. ---	100 KMΩ
H	K	50 meg. ohms min. ---	100 KMΩ
H	L	50 meg. ohms min. ---	100 KMΩ
H	M	50 meg. ohms min. ---	100 KMΩ
J	K	50 meg. ohms min. ---	150 MΩ
J	M	50 meg. ohms min. ---	150 MΩ
J	Case	50 meg. ohms min. ---	720 KMΩ
K	L	50 meg. ohms min. ---	150 MΩ
K	Case	50 meg. ohms min. ---	720 KMΩ
L	M	50 meg. ohms min. ---	150 MΩ
L	Case	50 meg. ohms min. ✓	>200 KMΩ
M	Case	50 meg. ohms min. ---	720 KMΩ

Accept  Initial ALST  
Reject  Date 6-10-70  
Photo Taken No

Comments: CYCLES = 61

5.3.10.2 Insulation Resistance

Port "A" Open 500 Volts D. C. Pins		Limit	Actual
From	To		
B	E	50 meg. ohms min.	>200 KMΩ
B	A	50 meg. ohms min.	>200 KMΩ
C	D	50 meg. ohms min.	>200 KMΩ
C	F	50 meg. ohms min.	>200 KMΩ

Accept  Initial ALST  
Reject  Date 6/10/70

Test Data Sheet  
Pulse Operated Flow Diverter Valve  
Specification 20M42517

Serial No. 009 Test Eng. RLM  
Mech. Tech. RLM Q. C. Eng. RLM  
Elect. Tech. RLM TECH

Continued

From	To	Limit	Actual
G	F	50 meg. ohms min.	> 200 KMΩ
G	H	50 meg. ohms min.	190 KMΩ
G	J	50 meg. ohms min.	> 200 KMΩ
G	K	50 meg. ohms min.	> 200 KMΩ
G	L	50 meg. ohms min.	> 200 KMΩ
G	M	50 meg. ohms min.	> 200 KMΩ
H	J	50 meg. ohms min.	> 200 MΩ
H	K	50 meg. ohms min.	> 20 KMΩ
H	L	50 meg. ohms min.	> 20 KMΩ
H	M	50 meg. ohms min.	> 20 KMΩ
J	K	50 meg. ohms min.	150 MΩ
J	M	50 meg. ohms min.	150 MΩ
J	Case	50 meg. ohms min.	> 20 KMΩ
K	L	50 meg. ohms min.	150 MΩ
K	Case	50 meg. ohms min.	> 20 KMΩ
L	M	50 meg. ohms min.	150 MΩ
L	Case	50 meg. ohms min.	> 20 KMΩ
M	Case	50 meg. ohms min.	> 20 KMΩ

Accept ✓ Initial RLM  
Reject \_\_\_\_\_ Date 6/10/70  
Photo Taken NO

Comments: CYCLES = 59 TOTAL

5.3.10.2 Insulation Resistance

Port "A" Open 500 Volts D. C. Pins			
From	To	Limit	Actual
B	E	50 meg. ohms min.	> 200 KMΩ
B	A	50 meg. ohms min.	> 200 KMΩ
C	D	50 meg. ohms min.	> 200 KMΩ
C	F	50 meg. ohms min.	> 200 KMΩ

Accept ✓ Initial RLM  
Reject \_\_\_\_\_ Date 6/10/70

Test Data Sheet  
Pulse Operated Flow Diverter Valve  
Specification 20M42517

Serial No. 007  
 Mech. Tech. LEO  
 Elect. Tech. LEO

Test Eng. BMR  
 Q. C. Eng. ALRT  
TEH

5.3.10.3 Insulation Resistance

Port "B" Open 500 Volts D. C. Pins		Limit	Actual
From	To		
A	B	50 meg. ohms min.	> 200 KMΩ
A	E	50 meg. ohms min.	> 200 KMΩ
D	C	50 meg. ohms min.	> 200 KMΩ
D	F	50 meg. ohms min.	> 200 KMΩ

Accept  Initial ALRT  
 Reject  Date 6-10-70

Comments: CYCLES = 64 TOTAL

5.3.11 Minimum Operating Voltage (Unpressurized Assembly)

Minimum Operating Voltage 100 ms Pulse, Unpressurized	Allowable	Actual			O. K.	Reject	Initial
		1	2	3			
Port "A"	18 volts d. c. max.	12.0	12.0	13.0	✓		ALRT
Port "B"	18 volts d. c. max.	14.5	14.0	14.5	✓		ALRT

Photo Taken No  
 Date 6-10-70

Comments: PHOTO TAKEN ON 1ST PULSE ON PORT A  
PHOTO TAKEN ON 1ST PULSE ON PORT B

5.3.12 Minimum Operating Voltage (Pressurized Assembly)

Minimum Operating Voltage 100ms Pulse 50 ± 5 psig, 100% Helium	Allowable	Actual			O. K.	Reject	Initial
		1	2	3			
Port "A"	18 volts d. c. max.	10.0	10.0	10.5	✓		ALRT
Port "B"	18 volts d. c. max.	12.8	12.5	12.6	✓		ALRT

Photo Taken No  
 Date 6-10-70

Comments: CYCLES = 96 (1 ML) TOTAL

PHOTOS TAKEN PORT A & B 1ST ACTIVATION ONLY  
2ND & 3RD ACTIVATION MONITORED ON SCOPE

Test Data Sheet  
Pulse Operated Flow Diverter Valve  
Specification 20M42517

Serial No. 018  
 Mech. Tech. REO  
 Elect. Tech. REO

Test Eng. RMP  
 Q. C. Eng. ALP  
 Tech

5.3.10.3 Insulation Resistance

Port "B" Open 500 Volts D. C. Pins			
From	To	Limit	Actual
A	B	50 meg. ohms min.	>200 kMΩ
A	E	50 meg. ohms min.	>200 kMΩ
D	C	50 meg. ohms min.	>200 kMΩ
D	F	50 meg. ohms min.	>200 kMΩ

Accept  Initial ALP  
 Reject  Date 6/10/70

Comments: CYCLES = 61 TOTAL

5.3.11 Minimum Operating Voltage (Unpressurized Assembly)

Minimum Operating Voltage 100 ms Pulse, Unpressurized	Allowable	Actual			O. K.	Reject	Initial
		1	2	3			
Port "A"	18 volts d. c. max.	13.5	12.1	12.8	✓		ALP
Port "B"	18 volts d. c. max.	17.0	14.5	16.5	✓		ALP

Photo Taken No  
 Date 6-10-70

Comments: PICTOS 1ST ACTIVATION ONLY. 2ND & 3RD ACTIVATION MINIMIZED.  
UP SCALE

5.3.12 Minimum Operating Voltage (Pressurized Assembly)

Minimum Operating Voltage 100ms Pulse 50 ± 5 psig, 100% Helium	Allowable	Actual			O. K.	Reject	Initial
		1	2	3			
Port "A"	18 volts d. c. max.	12.8	12.4	12.4	✓		ALP
Port "B"	18 volts d. c. max.	16.0	16.0	16.0	✓		ALP

Photo Taken No  
 Date 6-10-70

Comments: 92 (RMP)  
CYCLES = ~~52~~ TOTAL

SAME COMMENTS AS 5.3.11



Test Data Sheet  
Pulse Operated Flow Diverter Valve  
Specification 20M42517

Serial No. 607 Test Eng. RMR  
Mech. Tech. REC Q. C. Eng. ALRT  
Elect. Tech. REC TECH

5.3.13 Minimum Pulse Duration (Pressurized Assembly)

Minimum Pulse Duration, 28 Volts D. C. 100% Helium, 50 ± 5 psig	Allowable	Actual			O.K.	Reject	Initial
		1	2	3			
Port "A"	100 ms. max.	15.3	15.4	17.0	✓		ALRT
Port "B"		21.0	21.2	20.0	✓		ALRT

Photo Taken No  6-10-70  
Date 6-10-70

Comments: PHOTOS 1ST ACTIVATION ONLY  
CYCLES = 106 TOTAL

5.3.14 Minimum Pulse Duration (Unpressurized Assembly)

Minimum Pulse Duration, 28 Volts D. C. Zero Press	Allowable	Actual			O.K.	Reject	Initial
		1	2	3			
Port "A"	100 ms. max.	15.0	17.0	16.5	✓		ALRT
Port "B"		22.0	22.0	21.0	✓		ALRT

Photo Taken No  6-10-70  
Date 6-10-70

Comments: PHOTOS 1ST ACTIVATION ONLY  
CYCLES = 117.3 TOTAL

5.3.15 Power Consumption

Power 28 Volts D. C. Steady State	Allowable	Actual		O.K.	Reject	Initial
Voltage	28 ± .5	28.0		✓		ALRT
Current	1.14 amps max.	0.95	0.98	✓		ALRT
Power	31.5 watts max.	26.6	27.44	✓		ALRT

Photo Taken No  6-11-70  
Date 6-11-70

Comments: PORT B = 0.98 AMPS, PORT A = 0.95

Test Data Sheet  
Pulse Operated Flow Diverter Valve  
Specification 20M42517

Serial No. 108 Test Eng. PMR  
Mech. Tech. LEO O. C. BBB  
Elect. Tech. REO TECH ALPT

5.3.13 Minimum Pulse Duration (Pressurized Assembly)

Minimum Pulse Duration, 28 Volts D. C. 100% Helium, 50 ± 5 psig	Allowable	Actual			O. K.	Reject	Initial
		1	2	3			
Port "A"	100 ms. max.	16.5	15.2	16.0	✓		ALPT
Port "B"		17.5	16.5	17.0	✓		ALPT

Photo Taken No  6-10-70  
Date 6-10-70

Comments: CYCLES = 104 TOTAL  
SAME COMMENTS AS 5.3.11

5.3.14 Minimum Pulse Duration (Unpressurized Assembly)

Minimum Pulse Duration, 28 Volts D. C. Zero Press	Allowable	Actual			O. K.	Reject	Initial
		1	2	3			
Port "A"	100 ms. max.	17.5	17.5	16.5	✓		ALPT
Port "B"		17.5	18.0	16.0	✓		ALPT

Photo Taken No  6-10-70  
Date 6-10-70

Comments: SAME COMMENTS AS 5.3.11  
CYCLES = 114 TOTAL

5.3.15 Power Consumption

Power 28 Volts D. C. Steady State	Allowable	Actual	O. K.	Reject	Initial
Voltage	28 ± .5	28.0	✓		ALPT
Current	1.14 amps max.	1.07	1.04	✓	ALPT
Power	31.5 watts max.	29.76	29.12	✓	ALPT

Photo Taken No  6-11-70  
Date 6-11-70

Comments: PORT A = 1.07 PORT B = 1.04

**Pulse Operated Flow Diverter Valve  
Specification 20M42517**

Serial No. 007  
 Mech. Tech. TPS  
 Elect. Tech. —

Test Eng. RMR  
 Q. C. Eng. HPG, RSH  
TECH

**5.5.1 Vibration, Sinusoidal Excitation, Vehicle Dynamics**

Vehicle Dynamics per 5.5.1	Allowable	Actual	O. K.	Reject	Initial
Internal Pressure 20 ± 2 psig Methanol/Water		21.0 psig	✓		
Port C Axis	Accel. ±10%		✓		
Port A & B Axis	Freq. ±5%				
	Duration +10% - 0%		*		

\* LOWEST AVAILABLE FREQUENCY WAS 4CPS

CONTINUITY ACROSS PINS A-E  
 O.K. DURING RUNS

Photo Taken YES  
 Date 6-22-70 & 6-23-70  
 Control Accelerometer No. GR12

Comments: VACUUM PULLED ON EACH VALVE (0.5 PSIA) AND THEN  
FILLED WITH 80% METHANOL/20% WATER BY SPRINKLING 6-18-70  
NO EVIDENCE OF EXTERNAL LEAKAGE DURING VIBRATION

**5.5.2 Vibration, Sine Evaluation Criteria**

Sine Eval. per 5.5.2	Allowable	Actual	O. K.	Reject	Initial
Internal Pressure 20 ± 2.0 psig Methanol/Water		21.0 psig	✓		
Port C Axis	Accel. ±10%				
Port A & B Axis	Freq. ±5%		✓		
Longitudinal Axis	Duration +10% - 0%		✓		

Date 6-22-70 & 6-23-70  
 Control Accelerometer No. GR12

Comments: CONTINUITY ACROSS PINS A-E O.K. DURING RUNS  
NO EVIDENCE OF LEAKAGE DURING VIBRATION

**5.5.3 Vibration, Random Criteria, High Level**

Random per 5.5.3	Allowable	Actual	O. K.	Reject	Initial
Internal Pressure 20 ± 2.0 psig Methanol/Water		21.0 psig	✓		
Port C Axis	Overall ±10%		✓		
Port A&B Axis	PSD +100%	SEE	SEE		
Longitudinal Axis	- 30%	COMMENTS	COMMENTS		

Date 6-22-70 & 6-23-70

Comments: CONTINUITY ACROSS PINS A-E O.K. DURING RUNS  
PSD O.K. EXCEPT FOR ONE PEAK AT 1175 C/P, PORT C AXIS  
HIGH LEVEL. NO EVIDENCE OF LEAKAGE DURING VIBRATION

**Pulse Operated Flow Diverter Valve**  
**Specification 20M42517**

Serial No. 008  
 Mech. Tech. TPS  
 Elect. Tech. —

Test Eng. RMR  
 Q. C. Eng. H.P.G., R.S.H.  
 TECH.

**5.5.1 Vibration, Sinusoidal Excitation, Vehicle Dynamics**

Vehicle Dynamics per 5.5.1	Allowable	Actual	O. K.	Reject	Initial
Internal Pressure 20 ± 2 psig Methanol/Water	Accel. ±10% Freq. ±5%	21.0 psig	✓		RMR
Port C Axis					
Port A & B Axis	Duration +10% - 0%		✓		RMR

CONTINUITY ACROSS PINS A-E  
O.K. DURING RUNS

Photo Taken YES  
 Date 6-22-70 & 6-23-70  
 Control Accelerometer No. GR12

Comments: VACUUM PULLED ON EACH VALVE (0.5 PSIA) AND THEN  
FILLED WITH METHANOL 80% / WATER 20% BY SIPHONING  
NO EVIDENCE OF EXTERNAL LEAKAGE DURING VIBRATION 6-18-70

**5.5.2 Vibration, Sine Evaluation Criteria**

Sine Eval. per 5.5.2	Allowable	Actual	O. K.	Reject	Initial
Internal Pressure 20 ± 2.0 psig Methanol/Water		21.0 psig	✓		RMR
Port C Axis	Accel. ±10%				RMR
Port A & B Axis	Freq. ± 5%		✓		RMR
Longitudinal Axis	Duration +10% - 0%		✓		RMR

Date 6-22-70 & 6-23-70  
 Control Accelerometer No. GR12

Comments: CONTINUITY ACROSS PINS A-E O.K. DURING RUNS  
NO EVIDENCE OF LEAKAGE DURING VIBRATION

**5.5.3 Vibration, Random Criteria, High Level**

Random per 5.5.3	Allowable	Actual	O. K.	Reject	Initial
Internal Pressure 20 ± 2.0 psig Methanol/Water		21.0 psig	✓		RMR
Port C Axis	Overall ±10%		✓		RMR
Port A & B Axis	PSD +100%	SEE	SEE		RMR
Longitudinal Axis	- 30%	COMMENTS	COMMENTS		RMR

Date 6-22-70 & 6-23-70

Comments: CONTINUITY ACROSS PINS A-E O.K. DURING RUNS  
PSD O.K. EXCEPT FOR ONE PEAK AT 1175 CPS, PORT C AXIS  
HIGH LEVEL. NO EVIDENCE OF LEAKAGE DURING VIBRATION

Test Data Sheet  
Pulse Operated Flow Diverter Valve  
Specification 20M42517

Serial No. 007 Test Eng. R. G. RMR  
Mech. Tech. TPS Q. C. Eng. HFG  
Elect. Tech. — TECH

5.5.4 Vibration, Random Criteria Low Level

Random per 5.5.4	Allowable	Actual	O. K.	Reject	Initial
Internal Press 20 ± 2.0 psig Methanol/Water		21.0 psig	✓		
Port C Axis	Overall ± 10%		✓		
Port A&B Axis	PSD +100%		✓		
Longitudinal Axis	- 30%		✓		

Date 6-22-70 & 6-23-70

Comments: CONTINUITY O.K. ACCESS PINS A-E, DURING RUNS  
CYCLES = 175 TOTAL

Proof Pressure After Vibration

5 min @ 75 ± 7.5 psig	Allowable No Leakage or deformation	Actual		O. K.	Reject	Initial
		Time	Press			
		5 MIN.	75.5	✓		

Date 6-30-70

Comments: 5 MIN @ 75.5 PSIG + 2 MIN @ 73 PSIG  
CYCLES = 137 TOTAL

Vacuum After Vibration

	Allowable	Actual	O. K.	Reject	Initial
1. Internal Pressure	$1.94 \times 10^{-4}$ torr min.	$< 1 \times 10^{-3}$	✓		
2. External Pressure	14.7 psia	24.72 IN.Hg	✓		
3. Duration	5 minutes min.	6.9 MIN	✓		
4. Visual Examination	no deformation or permanent set	NONE	✓		

Date 6-30-70

Comments: CYCLES = 143

Test Data Sheet  
Pulse Operated Flow Diverter Valve  
Specification 20M42517

Serial No. 008  
Mech. Tech. TPS  
Elect. Tech.           

Test Eng. ZHR  
Q. C. Eng. HPG  
TEST

5.5.4 Vibration, Random Criteria Low Level

Random per 5.5.4	Allowable	Actual	O. K.	Reject	Initial
Internal Press 20 ± 2.0 psig Methanol/Water		21.0 psig	✓		
Port C Axis	Overall ± 10%		✓		
Port A&B Axis	PSD +100%		✓		
Longitudinal Axis	- 30%		✓		

Date 6-22-70 & 6-23-70  
Comments: CONTINUITY O.K. ACCESS PINS A-E DURING RUNS  
CYCLES = 122 TOTAL

Proof Pressure After Vibration

5 min @ 75 ± 7.5 psg	Allowable No Leakage or deformation	Actual		O. K.	Reject	Initial
		Time	Press			
		5 MIN	75.5	✓		

Date 6-30-70  
Comments: 5 MIN. @ 75.5 PSIG + 2 2 MIN @ 73 PSIG  
CYCLES = 134 TOTAL

Vacuum After Vibration

	Allowable	Actual	O. K.	Reject	Initial
1. Internal Pressure	1.94 x 10 <sup>-4</sup> torr min.	< 1x10 <sup>-5</sup>	✓		
2. External Pressure	14.7 psia	29.72 IN/Hg	✓		
3. Duration	5 minutes min.	6.9 MIN	✓		
4. Visual Examination	no deformation or permanent set	NONE	✓		

Date 6-30-70  
Comments: CYCLES = 140 TOTALS

Test Data Sheet  
Pulse Operated Flow Diverter Valve  
Specification 20M42517

Serial No. 007  
Mech. Tech. TPS  
Elect. Tech.           

Test Eng. RMR  
Q. C. Eng. HFG  
TECH

Leakage After Vibration

100% helium @ 50 ± 5 ppg Internal Press	Allowable	Actual	O. K.	Reject	Initial
	1.6 x 10 <sup>-6</sup> sccs	3.4 x 10 <sup>-8</sup>	✓		HFG

Date 7-2-70

Comments: STD LK = 3.4 x 10<sup>-8</sup> sccs/cycle, STD LK READING = 2.4  
ACTUAL READING = 2.2

TOTAL CYCLES = 157

Port A Methanol/Water	Allowable	Actual			O. K.	Reject	Initial
		1	2	3			
5.0 +.5 psig ΔP	0.20 sccs	.0018	.0018	.0036	✓		HFG
10.0 +1.0 psig ΔP	0.20 sccs	.0078	.009	.0018	✓		HFG
20.0 +2.0 psig ΔP	0.20 sccs	0.0	0.0	0.0	✓		HFG

Date 7-2-70

Port B Methanol/Water	Allowable	Actual			O. K.	Reject	Initial
		1	2	3			
5.0 +.5 psig ΔP	0.20 sccs	0.0	0.0	0.0	✓		HFG
10.0 +1.0 psig ΔP	0.20 sccs	0.0	0.0	.009	✓		HFG
20.0 +2.0 psig ΔP	0.20 sccs	.0018	0.0	0.0	✓		HFG

Date 7-2-70

Comments: TOTAL CYCLES = 165

Test Data Sheet  
Pulse Operated Flow Diverter Valve  
Specification 20M42517

Serial No. 028 Test Eng. RMR  
Mech. Tech. TPS Q. C. Eng. NPG  
Elect. Tech. \_\_\_\_\_ TECH

Leakage After Vibration

100% helium @ 50 ± 5 ppg Internal Press	Allowable	Actual	O. K.	Reject	Initial
	1.6 x 10 <sup>-6</sup> sccs	1.6 x 10 <sup>-7</sup>	✓		NPG

TOTAL CYCLES = 100

Date 7-2-70

Comments: STD LK = 3.4 x 10<sup>-8</sup> sccs/sec, STD LK READING = 2.4  
ACTUAL READING = 10.5



Port A Methanol/Water	Allowable	Actual			O. K.	Reject	Initial
		1	2	3			
5.0 ± 5 psig ΔP	0.20 sccs	0.0	0.0	0.0	✓		NPG
10.0 ± 1.0 psig ΔP	0.20 sccs	0.0	0.0	0.0	✓		NPG
20.0 ± 2.0 psig ΔP	0.20 sccs	0.0	0.0	0.0	✓		NPG

Date 6-30-70



Port B Methanol/Water	Allowable	Actual			O. K.	Reject	Initial
		1	2	3			
5.0 ± 5 psig ΔP	0.20 sccs	0.0	0.0	0.0	✓		NPG
10.0 ± 1.0 psig ΔP	0.20 sccs	0.0	0.0	0.0	✓		NPG
20.0 ± 2.0 psig ΔP	0.20 sccs	0.0	0.0	0.0	✓		NPG

Date 6-30-70



Comments: TOTAL CYCLES = 176



Test Data Sheet  
Pulse Operated Flow Diverter Valve  
Specification 20M42517

Serial No. 007  
Mech. Tech. TPS  
Elect. Tech. TPS

Test Eng. RMR  
Q. C. Eng. H. CARPENITO  
TECH



Circuit Resistance After Vibration

Port "A" Open Pins		Limit	Actual		
From	To		1	2	3
A	E	0.5 ohms max.	0.1	0.2	0.2
D	F	0.5 ohms max.	0.2	0.1	0.2
H	Case	0.5 ohms max.	0.1	0.3	0.2
L	J	25-29 ohms	27.2	28.2	28.2
B	E	Open Circuit	∞	∞	∞
C	F	Open Circuit	∞	∞	∞

Accept \_\_\_\_\_  
Reject \_\_\_\_\_

Initial RMR  
Date 7/2/70



Port "B" Open Pins		Limit	Actual		
From	To		1	2	3
A	E	Open Circuit	∞	∞	∞
D	F	Open Circuit	∞	∞	∞
H	Case	0.5 ohms max.	0.1	0.2	0.1
M	K	25-29 ohms	28.2	28.2	28.1
B	E	0.5 ohms max.	0.2	0.2	0.2
C	F	0.5 ohms max.	0.2	0.2	0.2

Accept \_\_\_\_\_  
Reject \_\_\_\_\_

Initial RMR  
Date 7/2/70



Comments: TEST CYCLES = 167

Test Data Sheet  
Pulse Operated Flow Diverter Valve  
Specification 20M42517

Serial No. 008  
Mech. Tech. TPS  
Elect. Tech. TPS

Test Eng. RMR  
Q. C. Eng. H. Carpenito  
TECH

Circuit Resistance After Vibration

Port "A" Open Pins		Limit	Actual		
From	To		1	2	3
A	E	0.5 ohms max.	0.1	0.2	0.2
D	F	0.5 ohms max.	0.2	0.2	0.1
H	Case	0.5 ohms max.	0.1	0.1	0.2
J	J	25-29 ohms	25.5	25.5	25.5
B	E	Open Circuit	∞	∞	∞
C	F	Open Circuit	∞	∞	∞

Accept    
Reject

Initial R.M.R.  
Date 7/2/70

Port "B" Open Pins		Limit	Actual		
From	To		1	2	3
A	E	Open Circuit	∞	∞	∞
D	F	Open Circuit	∞	∞	∞
H	Case	0.5 ohms max.	0.1	0.2	0.2
M	K	25-29 ohms	25.5	25.5	25.5
B	E	0.5 ohms max.	0.1	0.1	0.2
C	F	0.5 ohms max.	0.2	0.2	0.2

Accept    
Reject

Initial R.M.R.  
Date 7/2/70

Comments: TOTAL CYCLES = 178

Test Data Sheet  
Pulse Operated Flow Diverter Valve  
Specification 20M42517

Serial No. 007  
Mech. Tech. TPS  
Elect. Tech. TPS

Test Eng. RMR  
Q. C. Eng. H. CARPENITE  
TEH

Insulation Resistance After Vibration

500 Volts D. C. Pins		Limit	Actual
From	To		
A	C	50 meg. ohms min.	> 200KMEG
A	D	50 meg. ohms min.	> 200KMEG
A	F	50 meg. ohms min.	> 200KMEG
A	H	50 meg. ohms min.	> 200KMEG
A	J	50 meg. ohms min.	> 200KMEG
A	L	50 meg. ohms min.	> 200KMEG
A	M	50 meg. ohms min.	> 200KMEG
A	Case	50 meg. ohms min.	> 200KMEG
B	C	50 meg. ohms min.	> 200KMEG
B	D	50 meg. ohms min.	> 200KMEG
B	F	50 meg. ohms min.	> 200KMEG
B	A	50 meg. ohms min.	> 200KMEG
B	J	50 meg. ohms min.	> 200KMEG
B	K	50 meg. ohms min.	> 200KMEG
B	L	50 meg. ohms min.	> 200KMEG
B	M	50 meg. ohms min.	> 200KMEG
B	Case	50 meg. ohms min.	> 200KMEG
C	E	50 meg. ohms min.	↑ ↑ ↑ ↑ ↑ ↑ ↑ ↑ ↑ ↑
C	H	50 meg. ohms min.	
C	J	50 meg. ohms min.	
C	K	50 meg. ohms min.	
C	L	50 meg. ohms min.	
C	M	50 meg. ohms min.	
C	Case	50 meg. ohms min.	
D	E	50 meg. ohms min.	
D	H	50 meg. ohms min.	
D	J	50 meg. ohms min.	
D	K	50 meg. ohms min.	
D	L	50 meg. ohms min.	
D	M	50 meg. ohms min.	
D	Case	50 meg. ohms min.	> 200KMEG

Test Data Sheet  
Pulse Operated Flow Diverter Valve  
Specification 20M42517

Serial No. 008  
Mech. Tech. TPS  
Elect. Tech. TPS

Test Eng. RMR  
Q. C. Eng. HFC  
TECH

Insulation Resistance After Vibration

500 Volts D. C. Pins		Limit	Actual
From	To		
A	C	50 meg. ohms min.	↑ > 200KMEG
A	D	50 meg. ohms min.	
A	F	50 meg. ohms min.	
A	H	50 meg. ohms min.	
A	J	50 meg. ohms min.	
A	L	50 meg. ohms min.	
A	M	50 meg. ohms min.	
A	Case	50 meg. ohms min.	
B	C	50 meg. ohms min.	
B	D	50 meg. ohms min.	
B	F	50 meg. ohms min.	
B	A	50 meg. ohms min.	
B	J	50 meg. ohms min.	
B	K	50 meg. ohms min.	
B	L	50 meg. ohms min.	
B	M	50 meg. ohms min.	
B	Case	50 meg. ohms min.	
C	E	50 meg. ohms min.	↑ > 200KMEG
C	H	50 meg. ohms min.	
C	J	50 meg. ohms min.	
C	K	50 meg. ohms min.	
C	L	50 meg. ohms min.	
C	M	50 meg. ohms min.	
C	Case	50 meg. ohms min.	
D	E	50 meg. ohms min.	
D	H	50 meg. ohms min.	
D	J	50 meg. ohms min.	
D	K	50 meg. ohms min.	
D	L	50 meg. ohms min.	
D	M	50 meg. ohms min.	
D	Case	50 meg. ohms min.	↑ > 200KMEG

Fuse Operated Flow Diverter Valve  
Specification 20M42517

Serial No. 007  
Mech. Tech. TPS  
Elect. Tech. TPS

Test Eng. RMR  
Q. C. Eng. H. CARPENITO

Continued

From	To	Limit	Actual
E	F	50 meg. ohms min.	> 200 KMEG
E	H	50 meg. ohms min.	↑
E	J	50 meg. ohms min.	↓
E	K	50 meg. ohms min.	↓
E	L	50 meg. ohms min.	↓
E	M	50 meg. ohms min.	↓
E	Case	50 meg. ohms min.	> 200 KMEG
F	H	50 meg. ohms min.	↑
F	J	50 meg. ohms min.	↓
F	K	50 meg. ohms min.	↓
F	L	50 meg. ohms min.	↓
F	M	50 meg. ohms min.	↓
F	Case	50 meg. ohms min.	> 200 KMEG
G	A	50 meg. ohms min.	> 200 KMEG
G	B	50 meg. ohms min.	↑
G	C	50 meg. ohms min.	↓
G	D	50 meg. ohms min.	↓
G	E	50 meg. ohms min.	↓
G	F	50 meg. ohms min.	> 200 KMEG
G	H	50 meg. ohms min.	200 KMEG
G	J	50 meg. ohms min.	> 200 KMEG
G	K	50 meg. ohms min.	↑
G	L	50 meg. ohms min.	↓
G	M	50 meg. ohms min.	> 200 KMEG
H	J	50 meg. ohms min.	> 20 KMEG
H	K	50 meg. ohms min.	> 20 KMEG
H	L	50 meg. ohms min.	> 20 KMEG
H	M	50 meg. ohms min.	> 20 KMEG
J	K	50 meg. ohms min.	> 200 MEG
J	M	50 meg. ohms min.	> 200 MEG
J	Case	50 meg. ohms min.	150 KMEG
K	L	50 meg. ohms min.	180 MEG
K	Case	50 meg. ohms min.	150 KMEG
L	M	50 meg. ohms min.	200 MEG
L	Case	50 meg. ohms min.	150 KMEG
M	Case	50 meg. ohms min.	150 KMEG

Accept ✓  
Reject \_\_\_\_\_

Initial D.F.C.  
Date 7/2/70

Comments: \_\_\_\_\_

Serial No. 008  
 Mech. Tech. TPS  
 Elect. Tech. TPS

Test Eng. RMR  
 Q. C. Eng. H. F. CARPENITO  
 TECH.

Continued

From	To	Limit	Actual
E	F	50 meg. ohms min.	> 200K MEG
E	H	50 meg. ohms min.	
E	J	50 meg. ohms min.	
E	K	50 meg. ohms min.	
E	L	50 meg. ohms min.	
E	M	50 meg. ohms min.	
E	Case	50 meg. ohms min.	> 200K MEG
F	H	50 meg. ohms min.	
F	J	50 meg. ohms min.	
F	K	50 meg. ohms min.	
F	L	50 meg. ohms min.	
F	M	50 meg. ohms min.	
F	Case	50 meg. ohms min.	> 200K MEG
G	A	50 meg. ohms min.	
G	B	50 meg. ohms min.	
G	C	50 meg. ohms min.	
G	D	50 meg. ohms min.	
G	E	50 meg. ohms min.	
G	F	50 meg. ohms min.	
G	H	50 meg. ohms min.	
G	J	50 meg. ohms min.	
G	K	50 meg. ohms min.	
G	L	50 meg. ohms min.	
G	M	50 meg. ohms min.	> 200K MEG
H	J	50 meg. ohms min.	150K MEG
H	K	50 meg. ohms min.	150K MEG
H	L	50 meg. ohms min.	150K MEG
H	M	50 meg. ohms min.	150K MEG
J	K	50 meg. ohms min.	200 MEG
J	M	50 meg. ohms min.	200 MEG
J	Case	50 meg. ohms min.	150K MEG
K	L	50 meg. ohms min.	190 MEG
K	Case	50 meg. ohms min.	190K MEG
L	M	50 meg. ohms min.	190 MEG
L	Case	50 meg. ohms min.	190K MEG
M	Case	50 meg. ohms min.	150K MEG

Accept    
 Reject

Initial H. F. C.   
 Date 7/7/70

Comments: \_\_\_\_\_

7 July 70

Test Data Sheet  
 Pulse Operated Flow Diverter Valve  
 Specification 20M42517

Serial No. 007  
 Mech. Tech. TPS  
 Elect. Tech. TPS

Test Eng. RMR  
 Q. C. Eng. H. CARPENTIER  
TEST

Port "A" Open 500 Volts D. C. Pins		Limit	Actual
From	To		
B	E	50 meg. ohms min.	> 200KMEG
B	A	50 meg. ohms min.	> 200KMEG
C	D	50 meg. ohms min.	> 200KMEG
C	F	50 meg. ohms min.	> 200KMEG

Accept   
 Reject

Initial H.C.  
 Date 7/7/70

Port "B" Open 500 Volts D. C. Pins		Limit	Actual
From	To		
A	B	50 meg. ohms min.	> 200KMEG
A	E	50 meg. ohms min.	> 200KMEG
D	C	50 meg. ohms min.	> 200KMEG
D	F	50 meg. ohms min.	> 200KMEG

Accept   
 Reject

Initial H.C.  
 Date 7/7/70

Comments: TOTAL CYCLES = 170

Position Indicators After Vibration Noise

Covered under circuit resistance.

Minimum Operating Voltage After Vibration

Minimum Operating Voltage 100 ms Pulse, Unpressurized	Allowable	Actual			O. K.	Reject	Initial
		1	2	3			
Port "A"	18 volts d. c. max.	14.0	14.0	14.0	<input checked="" type="checkbox"/>		<u>H.C.</u>
Port "B"	18 volts d. c. max.	16.0	16.0	15.5	<input checked="" type="checkbox"/>		<u>H.C.</u>

Date 7/7/70

Comments: TOTAL CYCLES = 200

Pulse Operated Flow Diverter Valve  
Specification 20M42517

Serial No. 008  
Mech. Tech. TPS  
Elect. Tech. TPS

Test Eng. RMP  
Q. C. Eng. H.F. CARPENITO  
TECH

Port "A" Open 500 Volts D. C. Pins		Limit	Actual
From	To		
B	E	50 meg. ohms min.	> 200KMEG
B	A	50 meg. ohms min.	> 200KMEG
C	D	50 meg. ohms min.	> 200KMEG
C	F	50 meg. ohms min.	> 200KMEG

Accept   
Reject

Initial H.F.C.  
Date 7/7/70

Port "B" Open 500 Volts D. C. Pins		Limit	Actual
From	To		
A	B	50 meg. ohms min.	> 200KMEG
A	E	50 meg. ohms min.	> 200KMEG
D	C	50 meg. ohms min.	> 200KMEG
D	F	50 meg. ohms min.	> 200KMEG

Accept   
Reject

Initial H.F.C.  
Date 7/7/70

Comments: TOTAL CYCLES = 180

Position Indicators After Vibration Noise

Covered under circuit resistance.

Minimum Operating Voltage After Vibration

Minimum Operating Voltage 100 ms Pulse, Unpressurized	Allowable	Actual			O. K.	Reject	Init
		1	2	3			
Port "A"	18 volts d. c. max.	14.0	13.0	13.0	✓		OK
Port "B"	18 volts d. c. max.	16.0	16.0	14.0	✓		OK

Date 7-8-70

Comments: TOTAL CYCLES = 199



Test Data Sheet  
Pulse Operated Flow Diverter Valve  
Specification 20M42517

Serial No. 007 Test Eng. PMR  
Mech. Tech. TPS Q. C. Eng. D. V. GUIDO  
Elect. Tech. TPS TECH

*July 70*

Minimum Operating Voltage 100ms Pulse 50 ± 5 psig, 100% Helium	Allowable	Actual			O. K.	Reject	Initial
		1	2	3			
Port "A"	18 volts d. c. max.	13.5	13.5	13.0	✓		TPS
Port "B"	18 volts d. c. max.	14.5	14.5	14.5	✓		TPS

Date 7-7-70  
Comments: TOTAL CYCLES = 225

Minimum Pulse Duration After Vibration

*July 70*

Minimum Pulse Duration, 28 Volts D.C. 100% Helium, 50 ± 5 psig	Allowable	Actual			O. K.	Reject	Initial
		1	2	3			
Port "A"	100 ms. max.	34.0	35.0	34.0	✓		TPS
Port "B"		38.0	39.0	39.0	✓		TPS

Date 7-8-70  
Comments: VALVE CHANGES POSITION @ 15 MS BUT SWITCH DOES NOT ACTUATE UNTIL 34 MS.

*July 70*

Minimum Pulse Duration, 28 Volts D.C. Zero Press	Allowable	Actual			O. K.	Reject	Initial
		1	2	3			
Port "A"	100 ms. max.	30.0	34.0	33.0	✓		TPS
Port "B"		36.0	39.0	38.0	✓		TPS

Date 7-8-70  
Comments: SAME COMMENT AS ABOVE  
TOTAL CYCLES = 331

Test Data Sheet  
Pulse Operated Flow Diverter Valve  
Specification 20M42517

Serial No. 008 Test Eng. RMR  
Mech. Tech. TPS Q. C. Eng. D.V. GUIDO  
Elect. Tech. TPS TECH

8 July 70  
1544

Minimum Operating Voltage 100ms Pulse 50 ± 5 psig, 100% Helium	Allowable	Actual			O. K.	Reject	Initial
		1	2	3			
Port "A"	18 volts d. c. max.	14.0	13.0	13.0	✓		SVZ
Port "B"	18 volts d. c. max.	14.0	13.0	13.0	✓		SVZ

Date 7-8-70

Comments: TOTAL CYCLES = 211

Minimum Pulse Duration After Vibration

Minimum Pulse Duration, 28 Volts D. C. 100% Helium, 50 ± 5 psig	Allowable	Actual			O. K.	Reject	Initial
		1	2	3			
Port "A"	100 ms. max.	35.0	34.0	35.0	✓		SVZ
Port "B"		35.0	35.0	36.0	✓		SVZ

Date 7-8-70

Comments: TOTAL CYCLES = 232

Minimum Pulse Duration, 28 Volts D. C. Zero Press	Allowable	Actual			O. K.	Reject	Initial
		1	2	3			
Port "A"	100 ms. max.	37.0	32.0	32.0	✓		SVZ
Port "B"		37.0	32.0	36.0	✓		SVZ

Date 7-8-70

Comments: TOTAL CYCLES = 252

Test Data Sheet  
Pulse Operated Flow Diverter Valve  
Specification 20M42517

Serial No. 007  
Mech. Tech. TPS  
Elect. Tech. TPS

Test Eng. PMP  
Q. C. Eng. H.F. CARPENITO  
TECH

Power After Vibration

Power 28 Volts D. C. Steady State	Allowable	Actual		O. K.	Reject	Initial
		Port A	Port B			
Voltage	28 ± .5	28.0	28.0	✓		OK
Current	1.14 amps max	.975	.945	✓		OK
Power	31.5 watts max.	27.3	26.46	✓		OK

Date 7-8-70

Comments: \_\_\_\_\_

5.6.1 Transient Pulses, Minimum Operating Voltage Unpressurized

Minimum Operating Voltage 100 ms Pulse, Unpressurized	Allowable	Actual			O. K.	Reject	Init
		1	2	3			
Port "A"	18 volts d. c. max.	14.0	14.0	14.0	✓		OK
Port "B"	18 volts d. c. max.	15.0	15.0	15.5	✓		OK

Date 7-70-70

Comments: TOTAL CYCLES = 356

5.6.2 Transient Pulses, Minimum Operating Voltage Pressurized

Minimum Operating Voltage 100 ms Pulse 50 ± 5 psig, 100% Helium	Allowable	Actual			O. K.	Reject	Init
		1	2	3			
Port "A"	18 volts d. c. max.	14.0	14.0	14.0	✓		OK
Port "B"	18 volts d. c. max.	15.0	14.5	14.5	✓		OK

Date 7-7-70

Comments: TOTAL CYCLES = 368

Pulse Operated Flow Diverter Valve  
Specification 20M42517

Serial No. 008  
Mech. Tech. TPS  
Elect. Tech. TPS

Test Eng. RHR  
Q. C. Eng. \_\_\_\_\_  
TECH

Power After Vibration

Power	Allowable	Actual	O. K.	Reject	Initial
28 Volts D. C. Steady State Voltage	28 ± .5	28.0	✓		<i>[Handwritten]</i>
Current	1.14 amps max	1.065 1.145	✓		<i>[Handwritten]</i>
Power	31.5 watts max.	29.96 29.82	✓		<i>[Handwritten]</i>

*107 AMPS*  
*1.065 AMPS*

PORT A      PORT B

Date \_\_\_\_\_

Comments: \_\_\_\_\_

5.6.1 Transient Pulses, Minimum Operating Voltage Unpressurized

Minimum Operating Voltage 100 ms Pulse, Unpressurized	Allowable	Actual			O. K.	Reject	Initial
		1	2	3			
Port "A"	18 volts d. c. max.	15.0	13.0	13.0	✓		<i>[Handwritten]</i>
Port "B"	18 volts d. c. max.	16.0	14.0	14.0	✓		<i>[Handwritten]</i>

Date \_\_\_\_\_

7-8-70

Comments: \_\_\_\_\_

TOTAL CYCLES = 268

5.6.2 Transient Pulses, Minimum Operating Voltage Pressurized

Minimum Operating Voltage 100 ms Pulse 50 ± 5 psig, 100% Helium	Allowable	Actual			O. K.	Reject	Initial
		1	2	3			
Port "A"	18 volts d. c. max.	13.0	13.0	13.0	✓		<i>[Handwritten]</i>
Port "B"	18 volts d. c. max.	14.0	13.0	13.0	✓		<i>[Handwritten]</i>

Date \_\_\_\_\_

7-8-70

Comments: \_\_\_\_\_

TOTAL CYCLES = 273

Test Data Sheet  
Pulse Operated Flow Diverter Valve  
Specification 20M42517

Serial No. 007  
Mech. Tech. TPS  
Elect. Tech. TPS

Test Eng. RMR  
Q. C. Eng. D. V. Guido  
TECH

5.6.3 Transient Pulses, Minimum Pulse Duration (Pressuriz

Minimum Pulse Duration, 28 Volts D.C. 100% Helium, 50 ± 5 psig	Allowable	Actual			O.K.	Reject
		1	2	3		
Port "A"	100 ms. max.	300	350	350	✓	
Port "B"		330	320	320	✓	

Date 7-8-70

Comments: VALVE ACTUATES AT 15MS BUT SWITCH DOES NOT ACTUATE UNTIL 34 MS  
TOTAL CYCLES = 397

5.6.4 Transient Pulses, Minimum Pulse Duration (Unpressuriz

Minimum Pulse Duration, 28 Volts D.C. Zero Press	Allowable	Actual			O.K.	Reject
		1	2	3		
Port "A"	100 ms. max.	34.0	34.0	33.0	✓	
Port "B"		32.0	32.0	32.0	✓	

Date 7-8-70

Comments: VALVE ACTUATES AT 18-20 MS BUT SWITCH DOES NOT ACTUATE UNTIL 34 MS.  
TOTAL CYCLES = 425

5.6.5 Transient Pulses

Coil A Condition		Coil B Condition		Allowable	O.K.	Reject
Volts	Milliseconds	Volts	Milliseconds			
+28	Steady State	+72	.005	Will not change position	✓	
+28	Steady State	0	0	"	✓	
+28	Steady State	-19	9	"	✓	
+72	.005	+28	Steady State	"	✓	
0	0	+28	Steady State	"	✓	
-19	9	+28	Steady State	"	✓	

COMMENT: PINS A & E REMAINED CONTINUOUS DURING COIL "B" TRANSIENTS & REMAINED OPEN DURING COIL "A" TRANSIENTS

4 DEC 1970 **D-37**

Test Data Sheet  
Pulse Operated Flow Diverter Valve  
Specification 20M42517

Serial No. 008 Test Eng. RMA  
Mech. Tech. TPS Q. C. Eng. D.V. GUIDO  
Elect. Tech. TPS TECH

5.6.3 Transient Pulses, Minimum Pulse Duration (Pressurized)

Minimum Pulse Duration, 28 Volts D.C. 100% Helium, 50 ± 5 psig	Allowable	Actual			O.K.	Reject	Initial
		1	2	3			
Port "A"	100 ms. max.	38.0	36.0	36.0	✓		WRC
Port "B"		38.0	36.0	36.0	✓		WRC

Date 7-8-70  
Comments: TOTAL CYCLES = 290

5.6.4 Transient Pulses, Minimum Pulse Duration (Unpressurized)

Minimum Pulse Duration, 28 Volts D.C. Zero Press	Allowable	Actual			O.K.	Reject	Initial
		1	2	3			
Port "A"	100 ms. max.	36.0	36.0	36.0	✓		WRC
Port "B"		37.0	36.0	37.0	✓		WRC

Date 7-8-70  
Comments: TOTAL CYCLES = 306

5.6.5 Transient Pulses

Coil A Condition		Coil B Condition		Allowable	O.K.	Reject	Initial
Volts	Milliseconds	Volts	Milliseconds				
+28	Steady State	+72	.005	Will not change	✓		WRC
+28	Steady State	0	0	position	✓		WRC
+28	Steady State	-19	9	"	✓		WRC
+72	.005	+28	Steady State	"	✓		WRC
0	0	+28	Steady State	"	✓		WRC
-19	9	+28	Steady State	"	✓		WRC

COMMENT: PINS A & E REMAINED CONTINUOUS DURING COIL "B" TRANSIENTS, & REMAINED OPEN DURING COIL "A" TRANSIENTS  
-4 DEC 70 D-38

Test Data Sheet

Pulse Operated Flow Diverter Valve  
Specification 20M42517

Serial No. 007 Test Eng. PHR  
 Mech. Tech. TPS Q. C. Eng. HPG  
 Elect. Tech. TPS TEST

5.7 Life Cycling

1000 Cycles @ 28VDC Methanol/Water 3 amperes through Switches	Allowable	O. K.	Reject	Initial <i>HPG</i>
Examination	No failure or damage	✓		<i>HPG</i>

Photo Taken YES  
Date 8/25/70

Comments: S/N 007 = 1050 CYCLES, S/N 008 = 1020  
TOTAL CYCLES = 1987

5.6.6 Coil Transient Voltage

28 VDC coil actuated <10 sec measure peak transient on "off" sig- nal.	Allowable	Actual						O.K.	REJ.	INITIAL
		Coil A			Coil B					
		1	2	3	1	2	3			
Max. transient voltage not to exceed 150% of applied voltage		50V	50V	50V	50V	50V	50V			<i>HPG</i>

COMMENTS: \* MSF? HAS VERBALLY DIRECTED AICO TO PHOTO TAKEN YES  
CONTINUE WITH THE QUALIFICATION TEST PROGRAM DATE 7-22-70

TOTAL CYCLES = 1503

Test Data Sheet  
Pulse Operated Flow Diverter Valve  
Specification 20M42517

Serial No. 008 Test Eng. RMR  
Mech. Tech. TPS Q. C. Eng. HPG  
Elect. Tech. TPS TECH

5.7 Life Cycling

1000 Cycles @ 28VDC Methanol/Water 3 amperes through Switches	Allowable	O. K.	Reject	Initial
Examination	No failure or damage	✓		

Photo Taken \_\_\_\_\_  
Date \_\_\_\_\_

Comments: LIFE CYCLES = 1020  
TOTAL CYCLES = 1338

Coil Transient Voltage

28 VDC coil actuated 40 sec measure peak transient on "off" sig- nal.	Allowable  Max. transient voltage not to exceed 150% of applied voltage	Actual						C.K.	RES.	INITIAL
		Coil A			Coil B					
		1	2	3	1	2	3			
		52V	50V	50V	52V	50V	50V		✗	RMR

COMMENTS \* MSFC HAS VERBALLY DIRECTED ANCO TO PHOTO TAKEN YES

CONTINUE WITH QUALIFICATION TESTING DATE 7-22-70

TOTAL CYCLES = 1354



Test Data Sheet  
Pulse Operated Flow Diverter Valve  
Specification 20M42517

Serial No. 007  
Mech. Tech. TPS  
Elect. Tech. TPS

Leakage Checks During Life Test

Test Eng. PHR  
O. C. Eng. APG  
754  
710

Port A Methane/Water	Allowable	150 Cycles Actual			O.K.	Rej.	300 Cycles Actual			O.K.	Rej.	500 Cycles Actual			O.K.	Rej.	750 Cycles Actual			O.K.	Rej.	Ini.
		1	2	3			1	2	3			1	2	3			1	2	3			
0.45 psig ΔP	0.20 sccs	0.0	0.0	0.0	✓		0.0	0.0	0.0	✓		0.0	0.0	0.0	✓		0.0	0.0	0.0	✓		APG
0.04 psig ΔP	0.20 sccs	0.0	0.0	0.0	✓		0.0	0.0	0.0	✓		0.0	0.0	0.0	✓		0.0	0.0	0.0	✓		APG
0.02 psig ΔP	0.20 sccs	0.0	0.0	0.0	✓		0.0	0.0	0.0	✓		0.0	0.0	0.0	✓		0.0	0.0	0.0	✓		APG

Date 7/27/70  7/30/70  8/11/70  8-17-70

Comments: TOTAL CYCLES = 1523

Port B ethane/Water	Allowable	150 Cycles Actual			O.K.	Rej.	300 Cycles Actual			O.K.	Rej.	500 Cycles Actual			O.K.	Rej.	750 Cycles Actual			O.K.	Rej.	Ini.
		1	2	3			1	2	3			1	2	3			1	2	3			
0.5 psig ΔP	0.20 sccs	0.0	0.0	0.0	✓		0.0	0.0	0.0	✓		0.0	0.0	0.0	✓		0.0	0.0	0.0	✓		APG
0.01 psig ΔP	0.20 sccs	0.0	0.0	0.0	✓		0.0	0.0	0.0	✓		0.0	0.0	0.0	✓		0.0	0.0	0.0	✓		APG
0.02 psig ΔP	0.20 sccs	0.0	0.0	0.0	✓		0.0	0.0	0.0	✓		0.0	0.0	0.0	✓		0.0	0.0	0.0	✓		APG

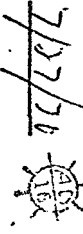
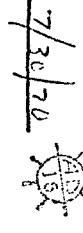
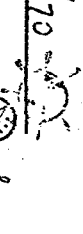
Date 7/27/70  7/30/70  8/11/70  B-12-70

Comments: TOTAL CYCLES = 1545

Serial No. 008  
 Tech. Tech. TPS  
 Lect. Tech. TPS

Test Data Sheet  
 Pulse Operated Flow Diverter Valve  
 Specification 20M42517

Leakage Checks During Life Test

Test Eng. RML  
 Q. C. Eng. TPS / AET  
 Tech TPS

Port A ethane/Water	Allowable	Cycles Actual			O.K.	Rej.	Ini.	Cycles Actual			O.K.	Rej.	Ini.	Cycles Actual			O.K.	Rej.	Ini.
		1	2	3				1	2	3				1	2	3			
0+5 psigΔP	0.20 sccs	0.0	0.0	0.0	✓		NPS	0.0	0.0	0.0	✓		NPS	0.0	0.0	0.0	✓		NPS
0+1 psigΔP	0.20 sccs	0.0	0.0	0.0	✓		NPS	0.0	0.0	0.0	✓		NPS	0.0	0.0	0.0	✓		NPS
0+2 psigΔP	0.20 sccs	0.0	0.0	0.0	✓		NPS	0.0	0.0	0.0	✓		NPS	0.0	0.0	0.0	✓		NPS

Date 7/25/70

7/30/70

8/11/70

8/17/70

Comments: TOTAL CYCLES = 1374

Port B ethane/Water	Allowable	Cycles Actual			O.K.	Rej.	Ini.	Cycles Actual			O.K.	Rej.	Ini.	Cycles Actual			O.K.	Rej.	Ini.
		1	2	3				1	2	3				1	2	3			
0+5 psigΔP	0.20 sccs	0.0	0.0	0.0	✓		NPS	0.0	0.0	0.0	✓		NPS	0.0	0.0	0.0	✓		NPS
0+1 psigΔP	0.20 sccs	0.0	0.0	0.0	✓		NPS	0.0	0.0	0.0	✓		NPS	0.0	0.0	0.0	✓		NPS
0+2 psigΔP	0.20 sccs	0.0	0.0	0.0	✓		NPS	0.0	0.0	0.0	✓		NPS	0.0	0.0	0.0	✓		NPS

Date 7/25/70

7/30/70

8/11/70

8/17/70

Comments: TOTAL CYCLES = 1400

Serial No. 007  
 Mech. Tech. TPS  
 Elect. Tech. IRS

Test Data Sheet  
 Pulse Operated Flow Diverter Valve  
 Specification 20M42517  
 Circuit Resistance During Life Test

Test Eng. ERM  
 Q. C. Eng. MIC / ACET  
TECH

Port A Open Pins	To	Limit	150 Cycles Actual			O.K.	Rej.	300 Cycles Actual			O.K.	Rej.	500 Cycles Actual			O.K.	Rej.	750 Cycles Actual			O.K.	Rej.
			1	2	3			1	2	3			1	2	3			1	2	3		
E		.50ohms max.	0.1	0.1	0.1	✓		0.1	0.1	0.1	✓		0.1	0.1	0.1	✓		0.1	0.1	0.1	✓	
F		.50ohms max.	0.1	0.1	0.1	✓		0.1	0.1	0.1	✓		0.1	0.1	0.1	✓		0.1	0.1	0.1	✓	
Case		.50ohms max.	0.0	0.1	0.0	✓		0.0	0.1	0.0	✓		0.0	0.1	0.0	✓		0.0	0.1	0.0	✓	
J		25-29 ohms	0.0	0.0	0.0	✓		0.0	0.0	0.0	✓		0.0	0.0	0.0	✓		0.0	0.0	0.0	✓	
E		open circuit	∞	∞	∞	✓		∞	∞	∞	✓		∞	∞	∞	✓		∞	∞	∞	✓	
F		open circuit	∞	∞	∞	✓		∞	∞	∞	✓		∞	∞	∞	✓		∞	∞	∞	✓	

Date 7/25/72 7/30/72 8/11/72  
 Comments: TOTAL CYCLES = 1532  
REL CEI

Port B Open Pins	To	Limit	150 Cycles Actual			O.K.	Rej.	300 Cycles Actual			O.K.	Rej.	500 Cycles Actual			O.K.	Rej.	750 Cycles Actual			O.K.	Rej.
			1	2	3			1	2	3			1	2	3			1	2	3		
E		open circuit	∞	∞	∞	✓		∞	∞	∞	✓		∞	∞	∞	✓		∞	∞	∞	✓	
F		open circuit	∞	∞	∞	✓		∞	∞	∞	✓		∞	∞	∞	✓		∞	∞	∞	✓	
Case		0.5ohms max.	0.0	0.0	0.0	✓		0.0	0.1	0.0	✓		0.0	0.1	0.1	✓		0.0	0.1	0.1	✓	
K		25-29 ohms	0.0	0.0	0.0	✓		0.0	0.1	0.0	✓		0.0	0.1	0.1	✓		0.0	0.1	0.1	✓	
E		0.5ohms max.	0.1	0.1	0.1	✓		0.1	0.1	0.1	✓		0.1	0.1	0.1	✓		0.1	0.1	0.1	✓	
F		0.5ohms max.	0.1	0.1	0.1	✓		0.1	0.1	0.1	✓		0.1	0.1	0.1	✓		0.1	0.1	0.1	✓	

Date 7/25/72 7/30/72 8/11/72  
 Comments: TOTAL CYCLES = 1564  
REL CEI

Position Indicators During Life Cycling  
 Covered by circuit resistance test.

Serial No. 008  
 Mech. Tech. TPS  
 Elect. Tech. TPS

Test Data Sheet  
 Pulse Operated Flow Diverter Valve  
 Specification: 20M42517

Test Eng. PHL  
 Q. C. Eng. HWG/BEST  
TECH

710

Pin	To	Limit	150 Cycles Actual			O.K.	Rej.	Ini.	300 Cycles Actual			O.K.	Rej.	Ini.	500 Cycles Actual			O.K.	Rej.	Ini.	750 Cycles Actual			O.K.	Rej.	Ini.		
			1	2	3				1	2	3				1	2	3				1	2	3					
E	To	.50hms max.	0.1	0.1	0.1	✓		0.1	0.1	0.1	✓		0.1	0.1	0.1	✓		0.1	0.1	0.1	✓							
F	To	.50hms max.	0.1	0.1	0.1	✓		0.1	0.1	0.1	✓		0.1	0.1	0.1	✓		0.1	0.1	0.1	✓							
Case	To	.50hms max.	0.1	0.1	0.1	✓		0.1	0.1	0.1	✓		0.1	0.1	0.1	✓		0.1	0.1	0.1	✓							
J	To	25-29 ohms	0.1	0.1	0.1	✓		0.1	0.1	0.1	✓		0.1	0.1	0.1	✓		0.1	0.1	0.1	✓							
E	To	open circuit	0.1	0.1	0.1	✓		0.1	0.1	0.1	✓		0.1	0.1	0.1	✓		0.1	0.1	0.1	✓							
F	To	open circuit	0.1	0.1	0.1	✓		0.1	0.1	0.1	✓		0.1	0.1	0.1	✓		0.1	0.1	0.1	✓							

Date 7/29/70  
 Comments: TPS

Date 7/31/70  
 Comments: TPS

Date 8/11/70  
 Comments: TPS

Date 8/19/70  
 Comments: TPS

TOTAL CYCLES = 1412

Pin	To	Limit	150 Cycles Actual			O.K.	Rej.	Ini.	300 Cycles Actual			O.K.	Rej.	Ini.	500 Cycles Actual			O.K.	Rej.	Ini.	750 Cycles Actual			O.K.	Rej.	Ini.	
			1	2	3				1	2	3				1	2	3				1	2	3				
E	To	open circuit	0.1	0.1	0.1	✓		0.1	0.1	0.1	✓		0.1	0.1	0.1	✓		0.1	0.1	0.1	✓						
F	To	open circuit	0.1	0.1	0.1	✓		0.1	0.1	0.1	✓		0.1	0.1	0.1	✓		0.1	0.1	0.1	✓						
Case	To	0.50hms max.	0.1	0.1	0.1	✓		0.1	0.1	0.1	✓		0.1	0.1	0.1	✓		0.1	0.1	0.1	✓						
K	To	25-29 ohms	0.1	0.1	0.1	✓		0.1	0.1	0.1	✓		0.1	0.1	0.1	✓		0.1	0.1	0.1	✓						
E	To	0.50hms max.	0.1	0.1	0.1	✓		0.1	0.1	0.1	✓		0.1	0.1	0.1	✓		0.1	0.1	0.1	✓						
F	To	0.50hms max.	0.1	0.1	0.1	✓		0.1	0.1	0.1	✓		0.1	0.1	0.1	✓		0.1	0.1	0.1	✓						

Date 7/29/70  
 Comments: TPS

Date 7/30/70  
 Comments: TPS

Date 8/11/70  
 Comments: TPS

Date 8/19/70  
 Comments: TPS

TOTAL CYCLES = 1474

Position Indicators During Life Cycling

Covered by circuit resistance test.

Serial No. 007  
 Mech. Tech. TPS  
 Elect. Tech. TPS

Test Data Sheet  
 Pulse Operated Flow Diverter Valve  
 Specification 20M42517

Test Eng. RMR  
 Q. C. Eng. TPS/MBR  
TECH

Minimum Operating Voltage During Life Cycling (Unpressurized Assembly)

Minimum Operating Voltage olt 100 ms. Unpressurized	150 Cycles Actual			300 Cycles Actual			500 Cycles Actual			750 Cycles Actual						
	1	2	3	1	2	3	1	2	3	1	2	3				
Port A	18 Volts	13.0	13.0	✓	14.0	12.5	12.5	✓	14.0	14.0	14.0	✓	15.0	15.0	15.0	✓
D.C. max.	18 Volts				14.0	14.5	14.5	✓	14.0	14.0	14.0	✓	15.0	15.0	15.0	✓
Port B	18 Volts	14.5	14.5	✓	14.5	14.5	14.5	✓	14.5	14.5	14.5	✓	14.5	14.5	14.5	✓
D.C. max.	18 Volts				14.5	14.5	14.5	✓	14.5	14.5	14.5	✓	14.5	14.5	14.5	✓

Date 7/29/70  
 Comments: VALVE CHANGES POSITION - 8-2 VOLTS LESS THAN SPECIFIED - ALMOST OK  
TO ACTUATE SWITCHES. TOTAL CYCLES = 16237  
8/17/70 - ALMOST OK  
8/17/70

Minimum Operating Voltage During Life Cycling (Pressurized Assembly)

Minimum Operating Voltage olt 100 ms. 50% He	150 Cycles Actual			300 Cycles Actual			500 Cycles Actual			750 Cycles Actual						
	1	2	3	1	2	3	1	2	3	1	2	3				
Port A	18 Volts	12.0	12.0	✓	14.0	11.5	11.5	✓	14.0	14.0	14.0	✓	15.0	14.0	14.0	✓
D.C. max.	18 Volts				14.0	11.5	11.5	✓	14.0	14.0	14.0	✓	15.0	14.0	14.0	✓
Port B	18 Volts	14.0	14.0	✓	14.0	13.5	13.5	✓	14.0	15.0	15.0	✓	15.0	15.0	15.0	✓
D.C. max.	18 Volts				14.0	13.5	13.5	✓	14.0	15.0	15.0	✓	15.0	15.0	15.0	✓

Date 7/29/70  
 Comments: TOTAL CYCLES = 1715  
7/30/70  
8/11/70  
8/17/70

Serial No. 608  
 Mech. Tech. TP5  
 Elect. Tech. TP5

Test Data Sheet  
 Pulse Operated Flow Diverter Valve  
 Specification 20M42517

Test Eng. RMR  
 Q. C. Eng. HPG/ACET/DS

Minimum Operating Voltage During Life Cycling (Unpressurized Assembly)

Minimum Operating Voltage 100 ms. Unpressurized	Allowable	150 Cycles Actual			o.k.	Rej.	300 Cycles Actual			o.k.	Rej.	500 Cycles Actual			o.k.	Rej.	750 Cycles Actual			o.k.	Rej.
		1	2	3			1	2	3			1	2	3			1	2	3		
Port A	18 Volts D.C. max.	18.0	17.1	12.5	✓		14.0	14.0	14.0	✓		14.0	14.0	14.0	✓		15.0	15.0	15.0	✓	
Port B	18 Volts D.C. max.	13.5	13.5	13.5	✓		14.5	14.5	14.5	✓		15.0	15.0	15.0	✓		15.5	15.0	15.5	✓	

Date 7/29/70 8/1/70 8-12-70 8/17/70  
 Comments: SWITCHES TRIP AT SAME MIN. VOLTAGE LEVEL TO ACTUATE VALVE

Minimum Pulse Duration During Life Cycling (Pressurized Assembly)

Minimum Operating Voltage 100 ms. 50% He	Allowable	150 Cycles Actual			o.k.	Rej.	300 Cycles Actual			o.k.	Rej.	500 Cycles Actual			o.k.	Rej.	750 Cycles Actual			o.k.	Rej.
		1	2	3			1	2	3			1	2	3			1	2	3		
Port A	18 Volts D.C. max.	12.5	12.0	10.5	✓		13.0	13.0	12.5	✓		13.5	13.5	13.5	✓		14.0	14.0	14.0	✓	
Port B	18 Volts D.C. max.	13.5	12.5	10.5	✓		14.0	14.0	14.0	✓		14.0	14.0	14.0	✓		14.5	14.5	14.5	✓	

Date 7/29/70 8/4/70 8-12-70 8/18/70  
 Comments: TOTAL CYCLES = 1500

Serial No. 007  
 Mech. Tech. TP3  
 Electr. Tech. TP5

Test Data Sheet  
 Pulse Operated Flow Diverter Valve  
 Specification 20M42517

Test Eng. ERM  
 Q. C. Eng. HPG/PKG  
 Tech. TP

Minimum Pulse Duration During Life Cycling (Pressurized Assembly)

Minimum Pulse Duration, 28VDC 0% He, ±5.0 psig	150 Cycles Actual			300 Cycles Actual			500 Cycles Actual			750 Cycles Actual								
	1	2	3	1	2	3	1	2	3	1	2	3						
Allowable	1	2	3	o.k.	Rej.	Ini.	1	2	3	o.k.	Rej.	Ini.	1	2	3	o.k.	Rej.	Ini.
Port A	100 ms max.	274	275	278	✓		1724	215	274	✓		1724	300	300	300	✓		1724
Port B	100 ms max.	320	320	325	✓		1724	300	300	✓		1724	300	300	300	✓		1724

Date 7-29-70 ~~7-30-70~~ 8/1/70 8/17/70

Comments: VALVE SWITCHES AT 15-18 MS BUT HIGHER PULSE WIDTH READ  
TO AVOID SWITCHES - TOTAL CYCLES = 1848

Minimum Pulse Duration During Life Cycling (Unpressurized Assembly)

Minimum Pulse Duration, 28VDC pressurized	150 Cycles Actual			300 Cycles Actual			500 Cycles Actual			750 Cycles Actual								
	1	2	3	o.k. <th>Rej. <th>Ini. <th>1</th> <th>2</th> <th>3</th> <th>o.k. <th>Rej. <th>Ini. <th>1</th> <th>2</th> <th>3</th> <th>o.k. <th>Rej. <th>Ini. </th></th></th></th></th></th></th></th>	Rej. <th>Ini. <th>1</th> <th>2</th> <th>3</th> <th>o.k. <th>Rej. <th>Ini. <th>1</th> <th>2</th> <th>3</th> <th>o.k. <th>Rej. <th>Ini. </th></th></th></th></th></th></th>	Ini. <th>1</th> <th>2</th> <th>3</th> <th>o.k. <th>Rej. <th>Ini. <th>1</th> <th>2</th> <th>3</th> <th>o.k. <th>Rej. <th>Ini. </th></th></th></th></th></th>	1	2	3	o.k. <th>Rej. <th>Ini. <th>1</th> <th>2</th> <th>3</th> <th>o.k. <th>Rej. <th>Ini. </th></th></th></th></th>	Rej. <th>Ini. <th>1</th> <th>2</th> <th>3</th> <th>o.k. <th>Rej. <th>Ini. </th></th></th></th>	Ini. <th>1</th> <th>2</th> <th>3</th> <th>o.k. <th>Rej. <th>Ini. </th></th></th>	1	2	3	o.k. <th>Rej. <th>Ini. </th></th>	Rej. <th>Ini. </th>	Ini.
Port A	100 ms max.	300	370	410	✓		1724	300	300	✓		1724	300	300	300	✓		1724
Port B	100 ms max.	310	320	320	✓		1724	300	300	✓		1724	300	300	300	✓		1724

Date 7/29/70 ~~7/30/70~~ 8/12/70 8/17/70

Comments: TOTAL CYCLES = 1959

Serial No. Car  
 Mech. Tech. TPS  
 Elect. Tech. TPS

Test Data Sheet  
 Pulse Operated Flow Diverter Valve  
 Specification 20M42517

Test Eng. RME  
 Q. C. Eng. HPG/DUS  
 JEB

Minimum Pulse Duration During Life Cycling (Pressurized Assembly)

Minimum Pulse Duration, 28VDC 0% He, 15.0 psig	Allowable	150 Cycles Actual			o.k.	Rej.	300 Cycles Actual			o.k.	Rej.	500 Cycles Actual			o.k.	Rej.	750 Cycles Actual			o.k.	Rej.	Ini.		
		1	2	3			1	2	3			1	2	3			1	2	3					
100 ms max.	22.0	21.0	21.0	21.0	✓		14.0	23.5	23.5	23.5	✓		14.0	23.5	23.5	23.5	✓		28.0	23.5	23.5	✓		14.0
100 ms max.	22.0	27.0	27.0	27.0	✓		14.0	23.5	23.5	23.5	✓		14.0	23.5	23.5	23.5	✓		29.0	23.5	23.5	✓		14.0

Date 7/29/70 8/7/70 8/18/70  
 Comments: AT 10 AT 10 AT 10

SAME PULSE WIDTH USED TO ACTIVATE SWITCH AS TO MAKE APPROPRIATE RESISTOR  
TOTAL CYCLES = 155  
 Minimum Pulse Duration During Life Cycling (Unpressurized Assembly)

Minimum Pulse Duration, 28VDC Unpressurized	Allowable	150 Cycles Actual			o.k.	Rej.	300 Cycles Actual			o.k.	Rej.	500 Cycles Actual			o.k.	Rej.	750 Cycles Actual			o.k.	Rej.	Ini.		
		1	2	3			1	2	3			1	2	3			1	2	3					
100 ms max.	26.5	27.0	27.0	27.0	✓		14.0	23.5	23.5	23.5	✓		14.0	23.5	23.5	23.5	✓		30.0	23.5	23.5	✓		14.0
100 ms max.	27.0	27.0	27.0	27.0	✓		14.0	23.5	23.5	23.5	✓		14.0	23.5	23.5	23.5	✓		30.0	23.5	23.5	✓		14.0

Date 7/29/70 8/7/70 8/12/70 8/15/70  
 Comments: AT 10 AT 10 AT 10

TOTAL CYCLES = 1600



Serial No. 007  
 Mech. Tech. TP2  
 Elect. Tech. TP5

Test Data Sheet  
 Pulse Operated Flow Diverter Valve  
 Specification 20M42517

Test Eng. RMK  
 O. C. Eng. HRG/DMS  
 Tech TECH

Power Consumption During Life Cycling

Power VDC Ready	Allowable	150 Cycles Actual			o.k.	Rej.	Ini.	300 Cycles Actual			o.k.	Rej.	Ini.	500 Cycles Actual			o.k.	Rej.	Ini.	750 Cycles Actual			o.k.	Rej.	Ini.
		1	2	3				1	2	3				1	2	3				1	2	3			
28 F. 5	1.14 amps	28	28	28	✓		NI	28	28	28	✓		NI	28	28	28	✓		NI	28	28	28	✓		NI
31.5 watts max.		28	28	28	✓		NI	28	28	28	✓		NI	28	28	28	✓		NI	28	28	28	✓		NI

Date 7/24/70 7-30-70 8/12/70 8/13/70  
 Comments: COIL A COIL A COIL A COIL A

COILS Puls M-K	COIL B Puls M-K			COIL B Puls M-K	COIL B Puls M-K	COIL B Puls M-K	COIL B Puls M-K	COIL B Puls M-K	COIL B Puls M-K	COIL B Puls M-K	COIL B Puls M-K	COIL B Puls M-K	COIL B Puls M-K	COIL B Puls M-K	COIL B Puls M-K	COIL B Puls M-K	COIL B Puls M-K	COIL B Puls M-K	COIL B Puls M-K	COIL B Puls M-K	COIL B Puls M-K	COIL B Puls M-K	COIL B Puls M-K	COIL B Puls M-K	COIL B Puls M-K																							
	1	2	3																																													
28 F. 5 Volts	28	28	28	✓		NI	28	28	28	✓		NI	28	28	28	✓		NI	28	28	28	✓		NI	28	28	28	✓		NI	28	28	28	✓		NI	28	28	28	✓		NI	28	28	28	✓		NI
1.14 Amps Max.	1.0	1.0	1.1	✓		NI	1.0	1.0	1.1	✓		NI	1.0	1.0	1.1	✓		NI	1.0	1.0	1.1	✓		NI	1.0	1.0	1.1	✓		NI	1.0	1.0	1.1	✓		NI	1.0	1.0	1.1	✓		NI	1.0	1.0	1.1	✓		NI
31.5 Watts Max.	28	28	28	✓		NI	28	28	28	✓		NI	28	28	28	✓		NI	28	28	28	✓		NI	28	28	28	✓		NI	28	28	28	✓		NI	28	28	28	✓		NI	28	28	28	✓		NI

8/12/70 8/17/70

Serial No. 228  
 Tech. Tech. TPS  
 ect. Tech. TPS

Test Data Sheet  
 Pulse Operated Flow Diverter Valve  
 Specification 20M42517

Test Eng. RMR  
 Q. C. Eng. HPG/DWG

Power Consumption During Life Cycling

er DC dy	Allowable	150 Cycles Actual			o.k.	Rej.	300 Cycles Actual			o.k.	Rej.	500 Cycles Actual			o.k.	Rej.	750 Cycles Actual			o.k.	Rej.	Ini.
		1	2	3			1	2	3			1	2	3			1	2	3			
age	28T.5	28	24	28	✓		22	22	22	✓		22	22	22	✓		22	22	22	✓		HPG
ent	- 1.14 amps	1.14	1.11	1.10	✓		1.09	1.09	1.09	✓		1.10	1.09	1.09	✓		1.10	1.10	1.09	✓		HPG
er	31.5 watts max.	31.0	31.0	31.0	✓		30.5	30.5	30.5	✓		31.0	31.0	30.5	✓		31.0	31.0	30.5	✓		HPG

Date 7/29/71 8/12/70 8/15/70  
 Comments: Coil B Coil B Coil A

Allowable	Coil B			Coil B			Coil B			Coil B		
	1	2	3	1	2	3	1	2	3	1	2	3
28T.5 volts	28	28	28	28	28	28	28	28	28	28	28	28
1.14 amps	1.09	1.09	1.09	1.09	1.09	1.09	1.09	1.09	1.09	1.10	1.09	1.09
31.5 WATTS MAX	30.5	30.5	30.5	30.5	30.5	30.5	31.0	31.0	30.5	31.0	30.5	30.5
	o.k.	o.k.	o.k.	o.k.	o.k.	o.k.	o.k.	o.k.	o.k.	o.k.	o.k.	o.k.
	Rej.	Rej.	Rej.	Rej.	Rej.	Rej.	Rej.	Rej.	Rej.	Rej.	Rej.	Rej.
	Ini.	Ini.	Ini.	Ini.	Ini.	Ini.	Ini.	Ini.	Ini.	Ini.	Ini.	Ini.

8/12/70  
 8/15/70

Test Data Sheet  
Pulse Operated Flow Diverter Valve  
Specification 20M42517

Serial No. 007 Test Eng. RMR  
Mech. Tech. MEN Q. C. Eng. HPG  
Elect. Tech. \_\_\_\_\_ TECH \_\_\_\_\_

Proof Pressure After Life Cycling

5 min @ 75 ± 7.5 psg	Allowable	Actual		O. K.	Reject	Initial
	No Leakage or deformation	Time	Press			
		5.0 MIN	75.0 PSIA	✓		

Photo Taken No  
Date 8/25/70

Comments: TOTAL CYCLES = 1944

Vacuum After Life Cycling

	Allowable	Actual	O. K.	Reject	Initial
1. Internal Pressure	$1.94 \times 10^{-4}$ torr min.	$< 1 \times 10^{-5}$	✓		HPG
2. External Pressure	14.7 psia	29.9 psia	✓		HPG
3. Duration	5 minutes min.	5.0	✓		HPG
4. Visual Examination	no deformation or permanent set		✓		

Photo Taken No  
Date 8/25/70

Comments: TOTAL CYCLES = 1949

Leakage After Life Cycling

100% helium @ 50 ± 5 ppg	Allowable	Actual	O. K.	Reject	Initial
Internal Press	$1.6 \times 10^{-6}$ sccs	$2.34 \times 10^{-8}$	✓		HPG

Photo Taken \_\_\_\_\_  
Date 8/25/70

Comments: STD LE =  $3.4 \times 10^{-8}$  STD LV 100. RD. = 3.2, ACTUAL = 0  
TOTAL CYCLES = 1954

Test Data Sheet  
Pulse Operated Flow Diverter Valve  
Specification 20M42517

Serial No. 008 Test Eng. PMR  
Mech. Tech. MER Q. C. Eng. HPG  
Elect. Tech. — TECH

Proof Pressure After Life Cycling

5 min @ 75 ± 7.5 psg	Allowable No Leakage or deformation	Actual		O. K.	Reject	Initi 
		Time 5:0 MIN	Press 75.6 psg			
				✓		

Photo Taken No  
Date 8/25/70

Comments: TOTAL CYCLES = 1605

Vacuum After Life Cycling

	Allowable	Actual	O. K.	Reject	Initi
1. Internal Pressure	$1.94 \times 10^{-4}$ torr min.	$2.1 \times 10^{-4}$	✓		
2. External Pressure	14.7 psia	29.9 IN.Hg	✓		
3. Duration	5 minutes min.	5:0	✓		
4. Visual Examination	no deformation or permanent set		✓		

Photo Taken No  
Date 8/25/70

Comments: TOTAL CYCLES = 1610

Leakage After Life Cycling

100% helium @ 50 ± 5 ppg	Allowable	Actual	O. K.	Reject	Initial
Internal Press	$1.6 \times 10^{-6}$ sccs	$2.33 \times 10^{-8}$	✓		

Photo Taken No  
Date 8/25/70

Comments: STD LK =  $3.4 \times 10^{-8}$ , STD INO. RD = 3.12, ACTUAL = 2.2  
TOTAL CYCLES = 1615

Pulse Operated Flow Diverter Valve  
Specification 20M42517

Serial No. 0007  
Mech. Tech. MEN  
Elect. Tech. —

Test Eng. PMP  
Q. C. Eng. HPC  
TECH

Port A Methanol/Water	Allowable	Actual			O. K.	Reject	Initial
		1	2	3			
5.0 ± 0.5 psig ΔP	0.20 sccs	OK	OK	OK	✓		MP
10.0 ± 1.0 psig ΔP	0.20 sccs	OK	OK	OK	✓		MP
20.0 ± 2.0 psig ΔP	0.20 sccs	OK	OK	OK	✓		MP

Date 7-26-70

Port B Methanol/Water	Allowable	Actual			O. K.	Reject	Initial
		1	2	3			
5.0 ± 0.5 psig ΔP	0.20 sccs	OK	OK	OK	✓		MP
10.0 ± 1.0 psig ΔP	0.20 sccs	OK	OK	OK	✓		MP
20.0 ± 2.0 psig ΔP	0.20 sccs	OK	OK	OK	✓		MP

Photo Taken No

Date 8/26/70

Comments: TOTAL CYCLES = 1900

Pulse Operated Flow Diverter Valve  
Specification 20M42517

Serial No. 008  
Mech. Tech. MEN  
Elect. Tech.                     

Test Eng. RMR  
Q. C. Eng. HPC  
TECH

Port A Methanol/Water	Allowable	Actual			O. K.	Reject	Initial
		1	2	3			
5.0 ± 0.5 psig ΔP	0.20 sccs	0.00	0.00	1.00	✓		HPC
10.0 ± 1.0 psig ΔP	0.20 sccs	0.00	0.00	0.00	✓		HPC
20.0 ± 2.0 psig ΔP	0.20 sccs	0.00	0.00	0.00	✓		HPC

Date 8-26-70

Port B Methanol/Water	Allowable	Actual			O. K.	Reject	Initial
		1	2	3			
5.0 ± 0.5 psig ΔP	0.20 sccs	0.00	0.00	0.00	✓		HPC
10.0 ± 1.0 psig ΔP	0.20 sccs	0.00	0.00	0.00	✓		HPC
20.0 ± 2.0 psig ΔP	0.20 sccs	0.00	0.00	0.00	✓		HPC

Photo Taken No  
Date 8/26/70

Comments: TOTAL CYCLES = 1621

Serial No. 007 Test Eng. RMP  
 Mech. Tech.                      Q. C. Eng. APG  
 Elect. Tech. MEW TECH

Circuit Resistance After Life Cycling

Port "A" Open Pins		Limit	Actual		
From	To		1	2	3
A	E	0.5 ohms max.	.2	.2	.2
D	F	0.5 ohms max.	.1	.2	.1
H	Case	0.5 ohms max.	.1	.1	.1
L	J	25-29 ohms	27.6	27.6	27.6
B	E	Open Circuit	∞	∞	∞
C	F	Open Circuit	∞	∞	∞

Accept  Initial HRM  
 Reject  Date 8-26-70

Port "B" Open Pins		Limit	Actual		
From	To		1	2	3
A	E	Open Circuit	∞	∞	∞
D	F	Open Circuit	∞	∞	∞
H	Case	0.5 ohms max.	.1	.1	.1
M	K	25-29 ohms	27.7	27.6	27.7
B	E	0.5 ohms max.	.1	.1	.1
C	F	0.5 ohms max.	.1	.1	.1

Accept  Initial HRM  
 Reject  Date 8-26-70

Comments: TOTAL CYCLES = 1966

Insulation Resistance After Life Cycling

500 Volts D. C. Pins		Limit	Actual
From	To		
A	C	50 meg. ohms min.	200 kM
A	D	50 meg. ohms min.	200 kM
A	F	50 meg. ohms min.	200 kM
A	H	50 meg. ohms min.	150 kM
A	J	50 meg. ohms min.	200 kM
A	L	50 meg. ohms min.	200 kM
A	M	50 meg. ohms min.	150 kM
A	Case	50 meg. ohms min.	200 kM
B	C	50 meg. ohms min.	190 kM
B	D	50 meg. ohms min.	200 kM
B	F	50 meg. ohms min.	200 kM
B	A	50 meg. ohms min.	200 kM

Serial No. 008  
 Mech. Tech.                       
 Elect. Tech. MEJ

Test Eng. RMR  
 Q. C. Eng. APC  
TECA

Circuit Resistance After Life Cycling

Port "A" Open Pins		Limit	Actual		
From	To		1	2	3
A	E	0.5 ohms max.	.1	.2	.2
D	F	0.5 ohms max.	.1	.1	.7
H	Case	0.5 ohms max.	0	0	0
L	J	25-29 ohms	25.3	25.3	25.7
B	E	Open Circuit	∞	∞	∞
C	F	Open Circuit	∞	∞	∞

Accept   
 Reject

Initial HPJ  
 Date F-26-70

Port "B" Open Pins		Limit	Actual		
From	To		1	2	3
A	E	Open Circuit	∞	∞	∞
D	F	Open Circuit	∞	∞	∞
H	Case	0.5 ohms max.	0	0	0
M	K	25-29 ohms	25.3	25.3	25.4
B	E	0.5 ohms max.	.2	.2	.1
C	F	0.5 ohms max.	.1	.1	.1

Accept   
 Reject

Initial HPJ  
 Date F-26-70

Photo Taken No

Comments: TOTAL CYCLES = 1627

Insulation Resistance After Life Cycling

500 Volts D. C. Pins		Limit	Actual
From	To		
A	C	50 meg. ohms min.	7200K MEG
A	D	50 meg. ohms min.	↓
A	F	50 meg. ohms min.	7200K MEG
A	H	50 meg. ohms min.	180K MEG
A	J	50 meg. ohms min.	7200K MEG
A	L	50 meg. ohms min.	↓
A	M	50 meg. ohms min.	7200K MEG
A	Case	50 meg. ohms min.	180K MEG
B	C	50 meg. ohms min.	7200K MEG
B	D	50 meg. ohms min.	↑
B	F	50 meg. ohms min.	7200K MEG
B	A	50 meg. ohms min.	↓

D-56



Test Data Sheet  
Pulse Operated Flow Diverter Valve  
Specification 20M42517

Serial No. 007  
Mech. Tech.                       
Elect. Tech. MEN

Test Eng. RMP  
Q. C. Eng. HPC  
TEG

Continued

From	To	Limit	Actual
B	K	50 meg. ohms min.	200 km
B	L	50 meg. ohms min.	200 km
B	M	50 meg. ohms min.	200 km
B	Case	50 meg. ohms min.	100 km
C	E	50 meg. ohms min.	200 km
C	H	50 meg. ohms min.	100 km
C	J	50 meg. ohms min.	200 km
C	K	50 meg. ohms min.	200 km
C	L	50 meg. ohms min.	200 km
C	M	50 meg. ohms min.	200 km
C	Case	50 meg. ohms min.	100 km
D	E	50 meg. ohms min.	190 km
D	H	50 meg. ohms min.	120 km
D	J	50 meg. ohms min.	200 km
D	K	50 meg. ohms min.	200 km
D	L	50 meg. ohms min.	200 km
D	M	50 meg. ohms min.	200 km
D	Case	50 meg. ohms min.	150 km
E	F	50 meg. ohms min.	200 km
E	H	50 meg. ohms min.	100 km
E	J	50 meg. ohms min.	200 km
E	K	50 meg. ohms min.	200 km
E	L	50 meg. ohms min.	200 km
E	M	50 meg. ohms min.	200 km
E	Case	50 meg. ohms min.	100 km
F	H	50 meg. ohms min.	190 km
F	J	50 meg. ohms min.	200 km
F	K	50 meg. ohms min.	200 km
F	L	50 meg. ohms min.	200 km
F	M	50 meg. ohms min.	200 km
F	Case	50 meg. ohms min.	100 km
G	A	50 meg. ohms min.	190 km
G	B	50 meg. ohms min.	150 km
G	C	50 meg. ohms min.	200 km
G	D	50 meg. ohms min.	200 km
G	E	50 meg. ohms min.	200 km



Test Data Sheet  
Pulse Operated Flow Diverter Valve  
Specification 20M42517

Serial No. 007  
Mech. Tech. \_\_\_\_\_  
Elect. Tech. MEW

Test Eng. RML  
Q. C. Eng. H&L  
TECH

Continued

From	To	Limit	Actual
G	F	50 meg. ohms min.	200 Km
G	H	50 meg. ohms min.	150 Km
G	J	50 meg. ohms min.	190 Km
G	K	50 meg. ohms min.	200 Km
G	L	50 meg. ohms min.	200 Km
G	M	50 meg. ohms min.	180 Km
H	J	50 meg. ohms min.	190 mΩ
H	K	50 meg. ohms min.	190 mΩ
H	L	50 meg. ohms min.	190 mΩ
H	M	50 meg. ohms min.	190 mΩ
J	K	50 meg. ohms min.	100 mΩ
J	M	50 meg. ohms min.	100 mΩ
J	Case	50 meg. ohms min.	190 mΩ
K	L	50 meg. ohms min.	100 mΩ
K	Case	50 meg. ohms min.	190 mΩ
L	M	50 meg. ohms min.	100 mΩ
L	Case	50 meg. ohms min.	190 mΩ
M	Case	50 meg. ohms min.	190 mΩ

Accept   
Reject \_\_\_\_\_

Initial H&L  
Date 9-26-70

Comments: \_\_\_\_\_

Port "A" Open 500 Volts D. C. Pins		Limit	Actual
From	To		
B	E	50 meg. ohms min.	200 Km
B	A	50 meg. ohms min.	200 Km
C	D	50 meg. ohms min.	190 Km
C	F	50 meg. ohms min.	190 Km

Accept   
Reject \_\_\_\_\_

Initial H&L  
Date 9-26-70

**Pulse Operated Flow Diverter Valve  
Specification 20M42517**

Serial No. 008  
 Mech. Tech. \_\_\_\_\_  
 Elect. Tech. MAN

Test Eng. PHR  
 Q. C. Eng. HCG  
TELA

Continued

From	To	Limit	Actual
G	F	50 meg. ohms min.	790 MEG
G	H	50 meg. ohms min.	120 MEG.
G	J	50 meg. ohms min.	7200 K MEG
G	K	50 meg. ohms min.	"
G	L	50 meg. ohms min.	120 MEG.
G	M	50 meg. ohms min.	7200 K MEG
H	J	50 meg. ohms min.	100 K MEG.
H	K	50 meg. ohms min.	90 K MEG.
H	L	50 meg. ohms min.	100 K MEG.
H	M	50 meg. ohms min.	90 MEG.
J	K	50 meg. ohms min.	120 MEG.
J	M	50 meg. ohms min.	100 MEG.
J	Case	50 meg. ohms min.	190 MEG.
K	L	50 meg. ohms min.	90 MEG.
K	Case	50 meg. ohms min.	200 MEG.
L	M	50 meg. ohms min.	100 MEG.
L	Case	50 meg. ohms min.	200 MEG.
M	Case	50 meg. ohms min.	200 MEG.

Accept \_\_\_\_\_  
 Reject ✓

Initial PHR  
 Date \_\_\_\_\_

Comments: \_\_\_\_\_

Port "A" Open 500 Volts D. C. Pins			
From	To	Limit	Actual
B	E	50 meg. ohms min.	7200 K MEG.
B	A	50 meg. ohms min.	"
C	D	50 meg. ohms min.	"
C	F	50 meg. ohms min.	190 K MEG.

Accept \_\_\_\_\_  
 Reject \_\_\_\_\_

Initial PHR  
 Date \_\_\_\_\_

Pulse Operated Flow Diverter Valve  
Specification 20M42517

Serial No. 007  
 Mech. Tech. — MEN —  
 Elect. Tech. — MEN —

Test Eng. RMP  
 Q. C. Eng. HPG  
TECH

Port "B" Open 500 Volts D. C. Pins		Limit	Actual
From	To		
A	B	50 meg. ohms min.	<del>720K OHMS</del> 190 kmg
A	E	50 meg. ohms min.	<del>190K OHMS</del> 190 kmg
D	C	50 meg. ohms min.	<del>190K OHMS</del> 190 kmg
D	F	50 meg. ohms min.	<del>300K OHMS</del> 190 kmg

Accept  Initial HPG  
 Reject  Date 8/24/70

Comments: \_\_\_\_\_

Position Indicators After Life Cycling

Covered by Circuit Resistance Measurements.

Minimum Voltage After Life Cycling

Minimum Operating Voltage 100ms Pulse, Unpressurized	Allowable	Actual			O. K.	Reject	Initial
		1	2	3			
Port "A"	18 volts d. c. max.	14.0	14.0	14.0	✓		HPG
Port "B"	18 volts d. c. max.	16.0	16.0	16.0	✓		HPG

Date 8-26-70

Comments: TOTAL CYCLES = 1976

Minimum Operating Voltage 100 ms Pulse 50 ± 5 psig, 100% Helium	Allowable	Actual			O. K.	Reject	Initial
		1	2	3			
Port "A"	18 volts d. c. max.	14.0	14.0	14.0	✓		HPG
Port "B"	18 volts d. c. max.	16.0	15.5	15.5	✓		HPG

Date 8.26.70

Comments: TOTAL CYCLES = 1986

Serial No. \_\_\_\_\_  
 Mech. Tech. MEN  
 Elect. Tech. MEN  
 Test Eng. RNR  
 Q. C. Eng. APG  
TECH

Port "B" Open 500 Volts D. C. Pins		Limit	Actual
From	To		
A	B	50 meg. ohms min.	7200K MEG
A	E	50 meg. ohms min.	"
D	C	50 meg. ohms min.	190K MEG
D	F	50 meg. ohms min.	200K MEG

Accept  Initial MEN  
 Reject \_\_\_\_\_ Date 8-26-70

Comments: \_\_\_\_\_

Position Indicators After Life Cycling

Covered by Circuit Resistance Measurements.

Minimum Voltage After Life Cycling

Minimum Operating Voltage 100ms Pulse, Unpressurized	Allowable	Actual			O. K.	Reject	Init
		1	2	3			
Port "A"	18 volts d. c. max.	15.5	15.0	15.0	<input checked="" type="checkbox"/>		<u>MEN</u>
Port "B"	18 volts d. c. max.	15.0	14.0	14.5	<input checked="" type="checkbox"/>		<u>MEN</u>

Date 8/27/70

Comments: TOTAL CYCLES = 1647

Minimum Operating Voltage 100 ms Pulse 50 ± 5 psig, 100% Helium	Allowable	Actual			O. K.	Reject	Init
		1	2	3			
Port "A"	18 volts d. c. max.	14.5	14.0	14.0	<input checked="" type="checkbox"/>		<u>MEN</u>
Port "B"	18 volts d. c. max.	14.5	14.0	14.5	<input checked="" type="checkbox"/>		<u>MEN</u>

Date 8/27/70

Comments: TOTAL CYCLES = 1635

Test Data Sheet  
Pulse Operated Flow Diverter Valve  
Specification 20M42517

Serial No. 007 Test Eng. PMR  
Mech. Tech. MEN Q. C. Eng. HPG  
Elect. Tech. MEN TECH

Pulse Duration After Life Cycling

Minimum Pulse Duration, 28 Volts D.C. 100% Helium, 50 ± 5 psig	Allowable	Actual			O.K.	Reject	Initial
		1	2	3			
Port "A"	100 ms. max.	27.5	28.4	27.5	✓		HPG
Port "B"		31.5	32.0	31.5	✓		HPG

Photo Taken 8/27/70   
Date \_\_\_\_\_

Comments: TOTAL CYCLES = 2001

Minimum Pulse Duration, 28 Volts D.C. Zero Press	Allowable	Actual			O.K.	Reject	Initial
		1	2	3			
Port "A"	100 ms. max.	29.5	27.0	27.5	✓		HPG
Port "B"		31.5	30.4	31.5	✓		HPG

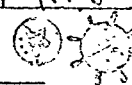
Photo Taken 8/27/70   
Date \_\_\_\_\_

Comments: TOTAL CYCLES = 2018

Power After Life Cycling

Power 28 Volts D.C. Steady State	Allowable	Actual			O.K.	Reject	Initial
		1	2	3			
Voltage	28 ± .5	28.0	28.28	28.28	✓		HPG
Current	- 1.14 amps	1.005	1.05	1.01	✓		HPG
Power	31.5 watts max.	28.1	31.14	31.1	✓		HPG

Coil A                      Coil B

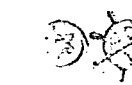
Date 8/27/70 

Comments: \_\_\_\_\_

Test Data Sheet  
Pulse Operated Flow Diverter Valve  
Specification 20M42517

Serial No. 008 Test Eng. PMR  
Mech. Tech. MEN Q. C. Eng. APG  
Elect. Tech. MEN TECH

Pulse Duration After Life Cycling

Minimum Pulse Duration, 28 Volts D. C. 100% Helium, 50 ± 5 psig	Allowable	Actual			O. K.	Reject	Initial
		1	2	3			
Port "A"	100 ms. max.	28.5	28.5	28.0	✓		HPS
Port "B"		28.5	28.0	28.0	✓		HPS

Photo Taken  
Date 8/27/70

Comments: TOTAL CYCLES = 1645

Minimum Pulse Duration, 28 Volts D. C. Zero Press	Allowable	Actual			O. K.	Reject	Initial
		1	2	3			
Port "A"	100 ms. max.	28.5	28.5	28.0	✓		HPS
Port "B"		28.0	28.0	28.0	✓		HPS

Photo Taken  
Date 8/27/70

Comments: TOTAL CYCLES = 1655

Power After Life Cycling

Power 28 Volts D. C. Steady State	Allowable	Actual			O. K.			Reject	Initial
		1	2	3	1	2	3		
Voltage	28 ± .5	28	28	28	28	28	28	✓	HPS
Current	- 1.14 amps	1.10	1.10	1.035	1.11	1.10	1.10	✓	HPS
Power	31.5 watts max.	31.0	31.0	30.6	31.0	31.0	31.0	✓	HPS

COIL A      COIL B

Date 8/27/70

Comments: \_\_\_\_\_



Test Data Sheet  
 Pulse Operated Flow Diverter Valve  
 Specification 20M42517

Serial No. 508  
 Mech. Tech. STB  
 Elect. Tech. STB

Test Eng. AME  
 O. C. Eng. AMS  
 Tech. TEH

5.8.1 High Temperature Gaseous

Ovalve @ 650F oil Volt= OVDC for Minutes	Allowable	Room Temp. Coil Resis. CURRENT/	165°F Resistance																	
			1	2	3	4	5	6	7	8	9	10								
oil "A"	Determine Max. Coil Temp. 170°F	1180	start 970	fin. 840	start 970	fin. 840	start 970	fin. 840	start 970	fin. 840	start 970	fin. 840	start 970	fin. 840	start 970	fin. 840	start 970	fin. 840	start 970	fin. 840
oil "B"	Determine Max. Coil Temp. 170°F	1180	start 970	fin. 840	start 970	fin. 840	start 970	fin. 840	start 970	fin. 840	start 970	fin. 840	start 970	fin. 840	start 970	fin. 840	start 970	fin. 840	start 970	fin. 840

Comments: 15 MINUTES BETWEEN EACH CURRENT TEST  
 TOTAL CYCLES = 1665

Photo Taken YES  
 Date SEPT 1, 1970

CURRENT ~ MILLIAMPERES  
 RESISTANCE ~ OHMS

Test Data Sheet  
Pulse Operated Flow Diverter Valve  
Specification 20M42517

Serial No.  
Mech. Tech.  
Elect. Tech.

Test Eng.  
Q. C. Eng.  
Tech

007  
J.P.J.  
J.P.J.  
R.H.R.  
N.B.G.

5.8.1 High Temperature Gaseous

oil Volt= 0VDC for Minutes	Allowable	Room Temp.	CURRENT / 1650 F. Resistance																						
			Coil Temp. Resis.	1	2	3	4	5	6	7	8	9	10	1	2	3	4	5	6	7	8	9	10		
oil "A"	Determine Max. Coil Temp. 174° F	108.0	900	850	900	850	900	850	900	850	900	850	900	850	900	850	900	850	900	850	900	850	900	850	900
oil "B"	Determine Max. Coil Temp. 174° F	108.0	900	850	900	850	900	850	900	850	900	850	900	850	900	850	900	850	900	850	900	850	900	850	900

Comments: 20<sup>25</sup> MINUTES BETWEEN EACH CURRENT TEST

TOTAL CYCLES = THIRTY - 2028

CURRENT ~ MILLIAMPERES  
RESISTANCE ~ OHMS

Photo Taken Yes  
Date SEPT 1, 1970

Test Data Sheet  
Pulse Operated Flow Diverter Valve  
Specification 20M42517

Serial No. 008 Test Eng. RMR  
Mech. Tech. TPS Q. C. Eng. RPG  
Elect. Tech. \_\_\_\_\_ TECH

Leakage After High Temperature Gaseous  
(Valve at 100°F)

Port A Methanol/Water	Allowable	Actual			O. K.	Reject	Initial
		1	2	3			
5.0 ± 5 psig ΔP	0.20 sccs	0.0	0.0	0.0	✓		Hrey
10.0 ± 1.0 psig ΔP	0.20 sccs	0.0	0.0	0.0	✓		Hrey
20.0 ± 2.0 psig ΔP	0.20 sccs	0.0	0.0	0.0	✓		Hrey

Date 9-15-70 

Port B Methanol/Water	Allowable	Actual			O. K.	Reject	Initial
		1	2	3			
5.0 ± 5 psig ΔP	0.20 sccs	0.0	0.0	0.0	✓		Hrey
10.0 ± 1.0 psig ΔP	0.20 sccs	0.0	0.0	0.0	✓		Hrey
20.0 ± 2.0 psig ΔP	0.20 sccs	0.0	0.0	0.0	✓		Hrey

Date 9-15-70 

Comments: TOTAL CYCLES = 1671

Circuit Resistance After High Temperature Gaseous  
(Valve at 100°F)

Port "A" Open Pins		Limit	Actual		
From	To		1	2	3
A	E	0.5 ohms max.	.2	.2	.2
D	F	0.5 ohms max.	.2	.2	.2
H	Case	0.5 ohms max.	.1	.1	.1
L	J	_____	26.7	26.7	26.7
B	E	Open Circuit	∞	∞	∞
C	F	Open Circuit	∞	∞	∞

Accept ✓  
Reject \_\_\_\_\_

Initial Hrey  
Date 9/16/70

Test Data Sheet  
Pulse Operated Flow Diverter Valve  
Specification 20M42517

Serial No. 008 007  
Mech. Tech. TPS  
Elect. Tech.                     

Test Eng. RMR  
Q. C. Eng. H.F. CARPENITO  
TECH

Leakage After High Temperature Gaseous  
(Valve at 100°F)

Port A Methanol/Water	Allowable	Actual			O. K.	Reject	Initial
		1	2	3			
5.0 ± 5 psig ΔP	0.20 sccs	0.0	0.0	0.0	✓		N.F.C.
10.0 ± 1.0 psig ΔP	0.20 sccs	0.0	0.0	0.0	✓		N.F.C.
20.0 ± 2.0 psig ΔP	0.20 sccs	0.0	0.0	0.0	✓		N.F.C.

Date 9-15-70

Port B Methanol/Water	Allowable	Actual			O. K.	Reject	Initial
		1	2	3			
5.0 ± 5 psig ΔP	0.20 sccs	0.0	0.0	0.0	✓		N.F.C.
10.0 ± 1.0 psig ΔP	0.20 sccs	0.0	0.0	0.0	✓		N.F.C.
20.0 ± 2.0 psig ΔP	0.20 sccs	0.0	0.0	0.0	✓		N.F.C.

Date 9-15-70

Comments: TOTAL CYCLES = 2034

Circuit Resistance After High Temperature Gaseous  
(Valve at 100°F)

Port "A" Open Pins		Limit	Actual		
From	To		1	2	3
A	E	0.5 ohms max.	0.2	0.2	0.2
D	F	0.5 ohms max.	0.1	0.2	0.2
H	Case	0.5 ohms max.	0.1	0.1	0.1
L	J		29.2	29.4	29.4
B	E	Open Circuit	OPEN	OPEN	OPEN
C	F	Open Circuit	OPEN	OPEN	OPEN

Accept ✓ Initial N.F.C.  
Reject                      Date 9/15/70

Test Data Sheet  
Pulse Operated Flow Diverter Valve  
Specification 20M42517

Serial No. 007  
Mech. Tech. \_\_\_\_\_  
Elect. Tech. TPS

Test Eng. RMP  
Q. C. Eng. H.F. CARONITO

Port "B" Open Pins		Limit	Actual		
			1	2	3
From. A	To E	Open Circuit	OPEN	OPEN	OPEN
D	F	Open Circuit	OPEN	OPEN	OPEN
H	Case	0.5 ohms max.	0.1	0.1	0.1
M	K	_____	29.4	29.4	29.3
B	E	0.5 ohms max.	0.2	0.2	0.2
C	F	0.5 ohms max.	0.2	0.2	0.2

Accept   
Reject \_\_\_\_\_

Initial H.F.C.  
Date 9/15/70

Comments: \_\_\_\_\_

TOTAL CYCLES = 2590

Insulation Resistance After High Temperature Gaseous

(Valve at 100°F)

500 Volts D. C. Pins		Limit	Actual
From	To		
A	C	50 meg. ohms min.	7200 MEG.
A	D	50 meg. ohms min.	↓
A	F	50 meg. ohms min.	7200 K MEG.
A	H	50 meg. ohms min.	130 K MEG.
A	J	50 meg. ohms min.	7200 K MEG.
A	L	50 meg. ohms min.	↓
A	M	50 meg. ohms min.	7200 K MEG.
A	Case	50 meg. ohms min.	120 K MEG.
B	C	50 meg. ohms min.	7200 K MEG.
B	D	50 meg. ohms min.	↓
B	F	50 meg. ohms min.	7200 K MEG.
B	A	50 meg. ohms min.	↓
B	J	50 meg. ohms min.	7200 K MEG.

Test Data Sheet  
Pulse Operated Flow Diverter Valve  
Specification 20M42517

Serial No. 008  
Mech. Tech.                       
Elect. Tech. JPS

Test Eng. RMR  
Q. C. Eng. H. CARPUNTO  
TECH

Port "B" Open Pins		Limit	Actual		
From	To		1	2	3
A	E	Open Circuit	$\infty$	$\infty$	$\infty$
D	F	Open Circuit	$\infty$	$\infty$	$\infty$
H	Case	0.5 ohms max.	.1	.1	.1
M	K		26.8	26.8	26.8
B	E	0.5 ohms max.	.2	.2	.2
C	F	0.5 ohms max.	.2	.2	.2

Accept   
Reject

Initial RMR  
Date 9/16/70

Comments: TOTAL CYCLES = 1677

Insulation Resistance After High Temperature Gaseous

(Valve at 100°F)

500 Volts D. C. Pins		Limit	Actual
From	To		
A	C	50 meg. ohms min.	> 200KMEG
A	D	50 meg. ohms min.	> 190KMEG
A	F	50 meg. ohms min.	> 190KMEG
A	H	50 meg. ohms min.	> 60KMEG
A	J	50 meg. ohms min.	190KMEG
A	L	50 meg. ohms min.	190KMEG
A	M	50 meg. ohms min.	190KMEG
A	Case	50 meg. ohms min.	60KMEG
B	C	50 meg. ohms min.	> 200KMEG
B	D	50 meg. ohms min.	> 200KMEG
B	F	50 meg. ohms min.	> 200KMEG
B	A	50 meg. ohms min.	150KMEG
B	J	50 meg. ohms min.	> 200KMEG

Test Data Sheet  
Pulse Operated Flow Diverter Valve  
Specification 20M42517

Serial No. 007  
Mech. Tech.                       
Elect. Tech. W.S

Test Eng. RMR  
Q. C. Eng. HPG  
TECH

Continued

From	To	Limit	Actual
B	K	50 meg. ohms min.	190 K MEG.
B	L	50 meg. ohms min.	190 K MEG.
B	M	50 meg. ohms min.	190 K MEG.
B	Case	50 meg. ohms min.	60 K MEG.
C	E	50 meg. ohms min.	200 K MEG.
C	H	50 meg. ohms min.	60 K MEG.
C	J	50 meg. ohms min.	190 K MEG.
C	K	50 meg. ohms min.	190 K MEG.
C	L	50 meg. ohms min.	190 K MEG.
C	M	50 meg. ohms min.	190 K MEG.
C	Case	50 meg. ohms min.	60 K MEG.
D	E	50 meg. ohms min.	> 200 K MEG.
D	H	50 meg. ohms min.	100 K MEG.
D	J	50 meg. ohms min.	> 200 K MEG.
D	K	50 meg. ohms min.	> 200 K MEG.
D	L	50 meg. ohms min.	> 200 K MEG.
D	M	50 meg. ohms min.	> 200 K MEG.
D	Case	50 meg. ohms min.	100 K MEG.
E	F	50 meg. ohms min.	> 200 K MEG.
E	H	50 meg. ohms min.	200 K MEG.
E	J	50 meg. ohms min.	↑
E	K	50 meg. ohms min.	↑
E	L	50 meg. ohms min.	↑
E	M	50 meg. ohms min.	↑
E	Case	50 meg. ohms min.	200 K MEG.
F	H	50 meg. ohms min.	> 200 K MEG.
F	J	50 meg. ohms min.	> 200 K MEG.
F	K	50 meg. ohms min.	190 K MEG.
F	L	50 meg. ohms min.	200 K MEG.
F	M	50 meg. ohms min.	200 K MEG.
F	Case	50 meg. ohms min.	> 200 K MEG.
G	A	50 meg. ohms min.	> 200 K MEG.
G	B	50 meg. ohms min.	↓
G	C	50 meg. ohms min.	↓
G	D	50 meg. ohms min.	↓
G	E	50 meg. ohms min.	> 200 K MEG.

Test Data Sheet  
Pulse Operated Flow Diverter Valve  
Specification 20M42517

Serial No. 008  
Mech. Tech.                       
Elect. Tech. JRS

Test Eng. RMK  
Q. C. Eng. H. CARENITO



Continued

From	To	Limit	Actual
B	K	50 meg. ohms min.	> 200KMEG
B	L	50 meg. ohms min.	> 200KMEG
B	M	50 meg. ohms min.	> 200KMEG
B	Case	50 meg. ohms min.	100KMEG
C	E	50 meg. ohms min.	150KMEG
C	H	50 meg. ohms min.	70KMEG
C	J	50 meg. ohms min.	150KMEG
C	K	50 meg. ohms min.	150KMEG
C	L	50 meg. ohms min.	150KMEG
C	M	50 meg. ohms min.	150KMEG
C	Case	50 meg. ohms min.	190KMEG
D	E	50 meg. ohms min.	60KMEG
D	H	50 meg. ohms min.	150KMEG
D	J	50 meg. ohms min.	100KMEG
D	K	50 meg. ohms min.	120KMEG
D	L	50 meg. ohms min.	150KMEG
D	M	50 meg. ohms min.	60KMEG
D	Case	50 meg. ohms min.	180KMEG
E	F	50 meg. ohms min.	60KMEG
E	H	50 meg. ohms min.	120KMEG
E	J	50 meg. ohms min.	120KMEG
E	K	50 meg. ohms min.	150KMEG
E	L	50 meg. ohms min.	150KMEG
E	M	50 meg. ohms min.	60KMEG
E	Case	50 meg. ohms min.	60KMEG
F	H	50 meg. ohms min.	90KMEG
F	J	50 meg. ohms min.	70KMEG
F	K	50 meg. ohms min.	70KMEG
F	L	50 meg. ohms min.	70KMEG
F	M	50 meg. ohms min.	100KMEG
F	Case	50 meg. ohms min.	60KMEG
G	A	50 meg. ohms min.	90KMEG
G	B	50 meg. ohms min.	120KMEG
G	C	50 meg. ohms min.	120KMEG
G	D	50 meg. ohms min.	120KMEG
G	E	50 meg. ohms min.	> 200KMEG





Test Data Sheet  
Pulse Operated Flow Diverter Valve  
Specification 20M42517

Serial No. 008  
Mech. Tech. \_\_\_\_\_  
Elect. Tech. TPS

Test Eng. PVR  
Q. C. Eng. H. CARONTO

Continued

From	To	Limit	Actual
G	F	50 meg. ohms min.	> 200KMEG
G	H	50 meg. ohms min.	120KMEG
G	J	50 meg. ohms min.	> 200KMEG
G	K	50 meg. ohms min.	> 200KMEG
G	L	50 meg. ohms min.	190KMEG
G	M	50 meg. ohms min.	> 200KMEG
H	J	50 meg. ohms min.	20KMEG
H	K	50 meg. ohms min.	20KMEG
H	L	50 meg. ohms min.	20KMEG
H	M	50 meg. ohms min.	20KMEG
J	K	50 meg. ohms min.	55MEG
J	M	50 meg. ohms min.	55MEG
J	Case	50 meg. ohms min.	> 200KMEG
K	L	50 meg. ohms min.	51MEG
K	Case	50 meg. ohms min.	> 200KMEG
L	M	50 meg. ohms min.	51MEG
L	Case	50 meg. ohms min.	20KMEG
M	Case	50 meg. ohms min.	20KMEG

Accept   
Reject \_\_\_\_\_

Initial N.J.C.  
Date 9/16/70

Comments: \_\_\_\_\_

Port "A" Open 500 Volts D. C. Pins		Limit	Actual
From	To		
B	E	50 meg. ohms min.	120KMEG
B	A	50 meg. ohms min.	100KMEG
C	D	50 meg. ohms min.	100KMEG
C	F	50 meg. ohms min.	70KMEG

Accept   
Reject \_\_\_\_\_

Initial N.J.C.  
Date 9/16/70



Test Data Sheet  
Pulse Operated Flow Diverter Valve  
Specification 20M42517

Serial No. 008  
Mech. Tech. \_\_\_\_\_  
Elect. Tech. JTS

Test Eng. RMP  
Q. C. Eng. H. CARPENITO

Port "B" Open 500 Volts D. C. Pins		Limit	Actual
From	To		
A	B	50 meg. ohms min.	> 200KMEG
A	E	50 meg. ohms min.	> 200KMEG
D	C	50 meg. ohms min.	> 200KMEG
D	F	50 meg. ohms min.	> 200KMEG

Accept   
Reject \_\_\_\_\_

Initial Nick C.  
Date 9/16/70

Comments: \_\_\_\_\_

Position Indicators After High Temperature Gaseous

(Valve at 100°F)

Covered by Circuit Resistance Test.

Minimum Voltage After High Temperature Gaseous

(Valve at 100°F)

Minimum Operating Voltage 100 ms Pulse, Unpressurized	Allowable	Actual			O. K.	Reject	Initial
		1	2	3			
Port "A"	18 volts d. c. max.	16.5	16.0	16.0	✓		
Port "B"	18 volts d. c. max.	16.5	17.0	17.0	✓		

Date 9/16/70

Comments: TOTAL CYCLES = 1689

Test Data Sheet  
Pulse Operated Flow Diverter Valve  
Specification 20M42517

Serial No. 007  
Mech. Tech. TPS  
Elect. Tech. TPS

Test Eng. RHR  
Q. C. Eng. H. F. CARPENITO  
TECH

Minimum Operating Voltage 100 ms Pulse 50 ± 5 psig, 100% Helium	Allowable	Actual			O. K.	Reject	Initi
		1	2	3			
Port "A"	18 volts d. c. max.	15.0	14.5	14.5	✓		
Port "B"	18 volts d. c. max.	16.5	16.0	16.0	—		

Comments: TOTAL CYCLES = 2010 Date 9/16/70

Pulse Duration After High Temperature Gaseous  
(Valve at 100°F)

Minimum Pulse Duration, 28 Volts D. C. 100% Helium, 50 ± 5 psig	Allowable	Actual			O. K.	Reject	Initial
		1	2	3			
Port "A"	100 ms. max.	28.0	28.0	28.0	✓		
Port "B"		32.0	32.0	32.0	✓		

Comments: VALVE ACTUATES AT ABOUT 22 MS, SWITCHES ACTUATE AT 28 MS  
30 MS " " " 32 MS  
TOTAL CYCLES = 2019 Date 9/16/70

Minimum Pulse Duration, 28 Volts D. C. Zero Press	Allowable	Actual			O. K.	Reject	Initial
		1	2	3			
Port "A"	100 ms. max.	28.0	28.5	29.5	✓		
Port "B"		32.0	32.5	32.5	—		

Comments: TOTAL CYCLES = 2094 Date 9/16/70

Test Data Sheet  
Pulse Operated Flow Diverter Valve  
Specification 20M42517

Serial No. 008  
Mech. Tech.                       
Elect. Tech. TPS

Test Eng. PMR  
Q. C. Eng. H. F. CARPENITO

Minimum Operating Voltage 100 ms Pulse 50 ± 5 psig, 100% Helium	Allowable	Actual			O. K.	Reject	Initial
		1	2	3			
Port "A"	18 volts d. c. max.	16.0	15.5	15.5	✓		
Port "B"	18 volts d. c. max.	16.0	16.5	16.0	✓		

Comments: TOTAL CYCLES = 1698

Date  9/14/70

Pulse Duration After High Temperature Gaseous

(Valve at 100°F)

Minimum Pulse Duration, 28 Volts D. C. 100% Helium, 50 ± 5 psig	Allowable	Actual			O. K.	Reject	Initial
		1	2	3			
Port "A"	100 ms. max.	28.2	28.2	27.4	✓		
Port "B"		28.5	27.0	28.5	✓		

Comments: TOTAL CYCLES = 1710

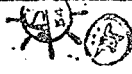
Date  9/16/70

Minimum Pulse Duration, 28 Volts D. C. Zero Press	Allowable	Actual			O. K.	Reject	Initial
		1	2	3			
Port "A"	100 ms. max.	29.0	29.2	28.5	✓		
Port "B"		29.5	30.0	30.0	✓		

Comments: TOTAL CYCLES = 1723

Date  9/16/70

Test Data Sheet  
Pulse Operated Flow Diverter Valve  
Specification 20M42517

Serial No. 007  
Mech. Tech. \_\_\_\_\_  
Elect. Tech. J.P.S.

Test Eng. RMR  
Q. C. Eng. H. CARPENTO  
TEST

Power After High Temperature Gaseous

(Valve at 100°F)

Power 28 Volts D. C. Steady State	Allowable	Actual			O. K.	Reject	Initial
		Coil A					
Voltage	28 ± .5	28.0	28.0	28.0	✓		D. J. C.
Current	1.14 amps	1.14	1.14	1.14	✓		D. J. C.
Power	31.5 watts max.	26.3	26.3	26.3	✓		D. J. C.
		Coil B					
		VOLT	28.0	28.0	28.0	✓	
		CURRENT	1.14	1.14	1.14	✓	
		POWER	26.3	26.3	26.3	✓	
			Date				

Comments: \_\_\_\_\_

9/17/70

5.8.2 Low Temperature Gaseous

Leakage, Valve at -65°F (Gaseous)

100% helium @ 50 ± 5 ppg	Allowable	Actual	O. K.	Reject	Initial
Internal Press	1.6 x 10 <sup>-6</sup> sccs	7 x 10 <sup>-8</sup>	✓		D. J. C.

Photo Taken  
Date

9-23-70

Comments: TOTAL CYCLES = 2097

Port A Methanol/Water	Allowable	Actual			O. K.	Reject	Initial
		1	2	3			
5.0 ± .5 psig ΔP	0.20 sccs	0.0033	0	0.0016	✓		D. J. C.
10.0 ± 1.0 psig ΔP	0.20 sccs	0.0016	0	0.0016	✓		D. J. C.
20.0 ± 2.0 psig ΔP	0.20 sccs	0.0016	0	0.0016	✓		D. J. C.

Date

10/16/70

Test Data Sheet  
Pulse Operated Flow Diverter Valve  
Specification 20M42517

Serial No. 008  
Mech. Tech. \_\_\_\_\_  
Elect. Tech. TPS

Test Eng. RWC  
Q. C. Eng. A. CARPENTO  
TECH

Power After High Temperature Gaseous

(Valve at 100°F)



Power 28 Volts D. C. Steady State	Allowable	COIL A			Actual	O. K.	Reject	Initial
		Voltage	Current	Power				
Voltage	28 ± .5	28.0	28.0	28.0	✓			<u>W.C.C.</u>
Current	1.14	1.04	1.02	1.02	✓			<u>W.C.C.</u>
Power	31.5 watts max.	29.1	26.8	26.8	✓			<u>W.C.C.</u>
		COIL B						
		VOLTAGE	CURRENT	POWER				
		28.0	1.02	28.6	✓			
		28.0	1.02	28.6	✓			
		28.0	1.02	28.6	✓			

9/17/70

Comments: \_\_\_\_\_

5.8.2 Low Temperature Gaseous

Leakage, Valve at -65°F (Gaseous)

100% helium @ 50 ± 5 ppg	Allowable	Actual	O. K.	Reject	Initial
Internal Press	1.6x10 <sup>-6</sup> sccs	1.94x10 <sup>-6</sup>	✓		<u>W.C.C.</u>

Photo Taken yes  
Date 9-24-70



Comments: TOTAL CYCLES = 1732

Port A Methanol/Water	Allowable	Actual			O. K.	Reject	Initial
		1	2	3			
5.0 ± .5 psig ΔP	0.20 sccs	0	0	0	✓		<u>W.C.C.</u>
10.0 ± 1.0 psig ΔP	0.20 sccs	0	0	0	✓		<u>W.C.C.</u>
20.0 ± 2.0 psig ΔP	0.20 sccs	0	0	0	✓		<u>W.C.C.</u>

Date 10/16/70

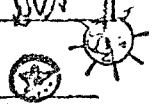



**Pulse Operated Flow Diverter Valve  
Specification 20M42517**

Serial No. 007  
 Mech. Tech.             
 Elect. Tech. RED

Test Eng. RMR  
 Q. C. Eng. H. CARPENITO

Port B Methanol/Water	Allowable	Actual			O. K.	Reject	Initial
		1	2	3			
5.0 ± .5 psig ΔP	0.20 sccs	0.0016	0	0	✓		RMR
10.0 ± 1.0 psig ΔP	0.20 sccs	0.0016	0.0016	0.0016	✓		OUT
20.0 ± 2.0 psig ΔP	0.20 sccs	0.0016	0.0016	0.0016	✓		OUT

Photo Taken ✓ YES  
 Date 10/16/70

Comments: TOTAL CYCLES = 2109

Circuit Resistance, Valve at -65°F (Gaseous)

Port "A" Open Pins		Limit	Actual		
From	To		1	2	3
A	E	0.5 ohms max.	0.2	0.1	0.1
D	F	0.5 ohms max.	0.2	0.1	0.1
H	Case	0.5 ohms max.	0.17	0.17	0.06
L	J	17.2 ohms min.	19.7	19.7	19.7
B	E	Open Circuit	OPEN	OPEN	OPEN
C	F	Open Circuit	OPEN	OPEN	OPEN

Accept ✓ Initial R.M.C.  
 Reject            Date 9/25/70

Port "B" Open Pins		Limit	Actual		
From	To		1	2	3
A	E	Open Circuit	OPEN	OPEN	OPEN
D	F	Open Circuit	OPEN	OPEN	OPEN
H	Case	0.5 ohms max.	0.17	0.07	0.17
M	K	17.2 ohms min.	19.7	19.9	20.0
B	E	0.5 ohms max.	0.17	0.18	0.17
C	F	0.5 ohms max.	0.16	0.17	0.18

Accept ✓ Initial R.M.C.  
 Reject            Date 9/25/70  
 Photo Taken           

Comments: TOTAL CYCLES = 2113

Pulse Operated Flow Diverter Valve  
Specification 20M42517

Serial No. 008  
 Mech. Tech. RE  
 Elect. Tech. REO

Test Eng. RMR  
 Q. C. Eng. A. CARPENITO

Port B Methanol/Water	Allowable	Actual			O. K.	Reject	Initial
		1	2	3			
5.0 ± .5 psig ΔP	0.20 sccs	0	0	0	✓		<i>[Initials]</i>
10.0 ± 1.0 psig ΔP	0.20 sccs	0	0	0	✓		<i>[Initials]</i>
20.0 ± 2.0 psig ΔP	0.20 sccs	0	0	0	✓		<i>[Initials]</i>

Photo Taken YES  
 Date 10/16/70

Comments: TOTAL CYCLES = 1746

Circuit Resistance, Valve at -65°F (Gaseous)

Port "A" Open Pins		Limit	Actual		
From	To		1	2	3
A	E	0.5 ohms max.	0.1	0.1	0.1
D	F	0.5 ohms max.	0.1	0.1	0.1
H	Case	0.5 ohms max.	0.2	0.1	0.2
L	J	17.2 ohms min.	17.7	17.7	17.8
B	E	Open Circuit	OPEN	OPEN	OPEN
C	F	Open Circuit	OPEN	OPEN	OPEN

Accept ✓ Initial A.A.C.  
 Reject \_\_\_\_\_ Date 9/25/70

Port "B" Open Pins		Limit	Actual		
From	To		1	2	3
A	E	Open Circuit	OPEN	OPEN	OPEN
D	F	Open Circuit	OPEN	OPEN	OPEN
H	Case	0.5 ohms max.	0.2	0.1	0.1
M	K	17.2 ohms min.	17.9	17.9	17.9
B	E	0.5 ohms max.	0.1	0.1	0.1
C	F	0.5 ohms max.	0.1	0.1	0.1

Accept ✓ Initial A.A.C.  
 Reject \_\_\_\_\_ Date 9/25/70  
 Photo Taken \_\_\_\_\_

Comments: TOTAL CYCLES 1749

Test Data Sheet  
 Pulse Operated Flow Diverter Valve  
 Specification 20M42517

Serial No. 007  
 Mech. Tech. \_\_\_\_\_  
 Elect. Tech. RSD

Test Eng. RMP  
 Q. C. Eng. HC

Insulation Resistance, Valve at -65°F (Gaseous)

500 Volts D. C. Pins			
From	To	Limit	Actual
A	C	50 meg. ohms min.	750 K MEG ↑ ↓ 750 K MEG
A	D	50 meg. ohms min.	
A	F	50 meg. ohms min.	
A	H	50 meg. ohms min.	
A	J	50 meg. ohms min.	
A	L	50 meg. ohms min.	
A	M	50 meg. ohms min.	
A	Case	50 meg. ohms min.	
B	C	50 meg. ohms min.	
B	D	50 meg. ohms min.	
B	F	50 meg. ohms min.	
B	A	50 meg. ohms min.	
B	J	50 meg. ohms min.	
B	K	50 meg. ohms min.	
B	L	50 meg. ohms min.	
B	M	50 meg. ohms min.	
B	Case	50 meg. ohms min.	
C	E	50 meg. ohms min.	
C	H	50 meg. ohms min.	
C	J	50 meg. ohms min.	
C	K	50 meg. ohms min.	
C	L	50 meg. ohms min.	
C	M	50 meg. ohms min.	
C	Case	50 meg. ohms min.	
D	E	50 meg. ohms min.	
D	H	50 meg. ohms min.	
D	J	50 meg. ohms min.	
D	K	50 meg. ohms min.	
D	L	50 meg. ohms min.	
D	M	50 meg. ohms min.	
D	Case	50 meg. ohms min.	
E	F	50 meg. ohms min.	
E	H	50 meg. ohms min.	
E	J	50 meg. ohms min.	
E	K	50 meg. ohms min.	
E	L	50 meg. ohms min.	

Test Data Sheet  
Pulse Operated Flow Diverter Valve  
Specification 20M42517

Serial No. 008  
Mech. Tech. \_\_\_\_\_  
Elect. Tech. RES

Test Eng. RME  
Q. C. Eng. H. CARPENTAS

Insulation Resistance, Valve at -65°F (Gaseous)

500 Volts D. C. Pins			
From	To	Limit	Actual
A	C	50 meg. ohms min.	> 200M
A	D	50 meg. ohms min.	> 200M
A	F	50 meg. ohms min.	> 200M
A	H	50 meg. ohms min.	> 200M
A	J	50 meg. ohms min.	> 200M
A	L	50 meg. ohms min.	> 200M
A	M	50 meg. ohms min.	> 200M
A	Case	50 meg. ohms min.	> 200M
B	C	50 meg. ohms min.	> 200M
B	D	50 meg. ohms min.	> 200M
B	F	50 meg. ohms min.	> 200M
B	A	50 meg. ohms min.	> 200M
B	J	50 meg. ohms min.	> 200M
B	K	50 meg. ohms min.	> 200M
B	L	50 meg. ohms min.	> 200M
B	M	50 meg. ohms min.	> 200M
B	Case	50 meg. ohms min.	> 200M
C	E	50 meg. ohms min.	> 200M
C	H	50 meg. ohms min.	> 200M
C	J	50 meg. ohms min.	> 200M
C	K	50 meg. ohms min.	> 200M
C	L	50 meg. ohms min.	> 200M
C	M	50 meg. ohms min.	> 200M
C	Case	50 meg. ohms min.	> 200M
D	E	50 meg. ohms min.	> 200M
D	H	50 meg. ohms min.	> 200M
D	J	50 meg. ohms min.	> 200M
D	K	50 meg. ohms min.	> 200M
D	L	50 meg. ohms min.	> 200M
D	M	50 meg. ohms min.	> 200M
D	Case	50 meg. ohms min.	> 200M
E	F	50 meg. ohms min.	> 200M
E	H	50 meg. ohms min.	> 200M
E	J	50 meg. ohms min.	> 200M
E	K	50 meg. ohms min.	> 200M
E	L	50 meg. ohms min.	> 200M

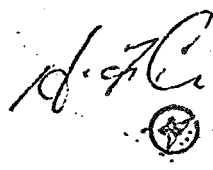
*H. Carpentas*  









**Test Data Sheet**  
**Pulse Operated Flow Diverter Valve**  
**Specification 20M42517**

Serial No. 008  
 Mech. Tech. \_\_\_\_\_  
 Elect. Tech. REO

Test Eng. RMR  
 Q. C. Eng. H. CARPENITO

Continued

From	To	Limit	Actual
E	M	50 meg. ohms min.	$> 200M$   $> 200M$ 
E	Case	50 meg. ohms min.	
F	H	50 meg. ohms min.	
F	J	50 meg. ohms min.	
F	K	50 meg. ohms min.	
F	L	50 meg. ohms min.	
F	M	50 meg. ohms min.	
F	Case	50 meg. ohms min.	
G	A	50 meg. ohms min.	
G	B	50 meg. ohms min.	
G	C	50 meg. ohms min.	$> 200M$  $> 200M$  $> 200M$  $> 200M$
G	E	50 meg. ohms min.	
G	F	50 meg. ohms min.	
G	H	50 meg. ohms min.	
G	J	50 meg. ohms min.	
G	K	50 meg. ohms min.	
G	L	50 meg. ohms min.	
G	M	50 meg. ohms min.	
H	J	50 meg. ohms min.	
H	K	50 meg. ohms min.	
H	L	50 meg. ohms min.	
H	M	50 meg. ohms min.	
J	K	50 meg. ohms min.	
J	M	50 meg. ohms min.	
J	Case	50 meg. ohms min.	
K	L	50 meg. ohms min.	
K	Case	50 meg. ohms min.	
L	M	50 meg. ohms min.	
L	Case	50 meg. ohms min.	
M	Case	50 meg. ohms min.	

Accept  \_\_\_\_\_  
 Reject \_\_\_\_\_  
 Photo Taken \_\_\_\_\_

Initial N. G. C.  
 Date 9/29/70

Comments: \_\_\_\_\_

Test Data Sheet  
Pulse Operated Flow Diverter Valve  
Specification 20M42517

Serial No. 007 Test Eng. RMR  
Mech. Tech. \_\_\_\_\_ Q. C. Eng. HPG  
Elect. Tech. RSD

Port "A" Open 500 Volts D. C. Pins		Limit	Actual
From	To		
B	E	50 meg. ohms min.	> 50 KMEG.
B	A	50 meg. ohms min.	↓
C	D	50 meg. ohms min.	↓
C	F	50 meg. ohms min.	> 50 KMEG.

Accept  Initial HPG  
Reject \_\_\_\_\_ Date 9/28/70

Port "B" Open 500 Volts D. C. Pins		Limit	Actual
From	To		
A	B	50 meg. ohms min.	> 50 KMEG.
A	E	50 meg. ohms min.	↓
D	C	50 meg. ohms min.	↓
D	F	50 meg. ohms min.	> 50 KMEG.

Accept  Initial HPG  
Reject \_\_\_\_\_ Date 9/28/70

Comments: TOTAL CYCLES = 2115

Position Indicators, Valve at -65° F (Gaseous)

Covered by Circuit Resistance Test.

Test Data Sheet  
Pulse Operated Flow Diverter Valve  
Specification 20M42517

Serial No. 008  
Mech. Tech. \_\_\_\_\_  
Elect. Tech. REO

Test Eng. RMR  
Q. C. Eng. H. CARPANO

Port "A" Open 500 Volts D. C. Pins			
From	To	Limit	Actual
B	E	50 meg. ohms min.	>200M
B	A	50 meg. ohms min.	>200M
C	D	50 meg. ohms min.	>200M
C	F	50 meg. ohms min.	>200M

Accept   
Reject \_\_\_\_\_

Initial N.F.C.  
Date 9/28/70

Port "B" Open 500 Volts D. C. Pins			
From	To	Limit	Actual
A	B	50 meg. ohms min.	>200M
A	E	50 meg. ohms min.	>200M
D	C	50 meg. ohms min.	>200M
D	F	50 meg. ohms min.	>200M

Accept   
Reject \_\_\_\_\_

Initial N.F.C.  
Date 9/28/70

Comments: TOTAL CYCLES = 1750

Position Indicators, Valve at -65° F (Gaseous)

Covered by Circuit Resistance Test.

2789



Test Data Sheet  
Pulse Operated Flow Diverter Valve  
Specification 20M42517

Serial No. 007 Test Eng. RMR  
Mech. Tech. REO Q. C. Eng. CARPENITO  
Elect. Tech. REO

Minimum Operating Voltage, Valve at -65° F (Gaseous)

Minimum Operating Voltage 100 ms Pulse, Unpressurized	Allowable	Actual			O. K.	Reject	Initial
		1	2	3			
Port "A"	18 volts d. c. max.	13.0	13.0	13.0	✓		H <sub>1</sub> <sup>2</sup>
Port "B"	18 volts d. c. max.	12.0	12.0	12.0	✓		H <sub>1</sub> <sup>2</sup>

Photo Taken ✓  
Date 10-14-70

Comments: TOTAL CYCLES = 2141

Minimum Operating Voltage 100 ms Pulse 50 ± 5 psig, 100% Helium	Allowable	Actual			O. K.	Reject	Initial
		1	2	3			
Port "A"	18 volts d. c. max.	12.0	12.0	12.0	✓		H <sub>1</sub> <sup>2</sup>
Port "B"	18 volts d. c. max.	12.0	12.0	12.0	✓		H <sub>1</sub> <sup>2</sup>

Photo Taken ✓  
Date 10-14-70

Comments: TOTAL CYCLES = 2159

Test Data Sheet  
Pulse Operated Flow Diverter Valve  
Specification 20M42517

Serial No. 008 Test Eng. RMR  
Mech. Tech. REO Q. C. Eng. APG  
Elect. Tech. REO TEKA

Minimum Operating Voltage, Valve at -65° F (Gaseous)

Minimum Operating Voltage 100 ms Pulse, Unpressurized	Allowable	Actual			O. K.	Reject	Initial
		1	2	3			
Port "A"	18 volts d. c. max.	13.0	13.0	13.0	✓		N/A
Port "B"	18 volts d. c. max.	13.0	13.0	13.0	✓		N/A

Photo Taken ✓  
Date 10/15/70

Comments: TOTAL CYCLES = 1781

Minimum Operating Voltage 100 ms Pulse 50 ± 5 psig, 100% Helium	Allowable	Actual			O. K.	Reject	Initial
		1	2	3			
Port "A"	18 volts d. c. max.	13.0	13.0	13.0	✓		N/A
Port "B"	18 volts d. c. max.	13.0	13.0	13.0	✓		N/A

Photo Taken ✓  
Date 10/15/70

Comments: TOTAL CYCLES = 1797

Test Data Sheet  
Pulse Operated Flow Diverter Valve  
Specification 20M42517

Serial No. 007 Test Eng. RMR  
Mech. Tech. REO Q. C. Eng. NPG  
Elect. Tech. REO TEP

5.3.1

Minimum Pulse Duration, Valve at -65°F (Gaseous)

Minimum Pulse Duration, 28 Volts D. C. 100% Helium, 50 ± 5 psig	Allowable	Actual			O.K.	Reject	Initial
		1	2	3			
Port "A"	100 ms. max.	14.0	14.0	14.0	✓		H24
Port "B"		16.0	16.0	16.0	✓		H24

Photo Taken ✓  
Date 10/14/70

Comments: TOTAL CYCLES = 2173

Minimum Pulse Duration, 28 Volts D. C. Zero Press	Allowable	Actual			O.K.	Reject	Initial
		1	2	3			
Port "A"	100 ms. max.	20.0	20.0	20.0	✓		H27
Port "B"		15.0	15.0	15.0	✓		H27

Photo Taken ✓  
Date 10/14/70

Comments: TOTAL CYCLES = 2189

Power, Valve at -65°F (Gaseous)

Power 28 Volts D. C. Steady State	Allowable	PORT		O.K.	Reject	Initial
		A	B			
Voltage	28 ± .5	28.0	28.0	✓		H27
Current	1.61 amps	1.3	1.3	✓		H27
Power	45.0 watts max	36.4	36.4	✓		H27

Photo Taken ✓  
Date 10/17/70

Comments: TOTAL CYCLES = 2191

Test Data Sheet

Pulse Operated Flow Diverter Valve  
Specification 20M42517

Serial No. 008  
Mech. Tech. PED  
Elect. Tech. REC

Test Eng. RMR  
Q. C. Eng. HPS  
TECH

5.3.1

Minimum Pulse Duration, Valve at -65°F (Gaseous)

Minimum Pulse Duration, 28 Volts D. C. 100% Helium, 50 ± 5 psig	Allowable	Actual			O. K.	Reject	Initial
		1	2	3			
Port "A"	100 ms. max.	23	23	23	✓		HPS
Port "B"		24	25	23	✓		HPS

Photo Taken   
Date 10/15/70

Comments: TOTAL CYCLES = 1813

Minimum Pulse Duration, 28 Volts D. C. Zero Press	Allowable	Actual			O. K.	Reject	Initial
		1	2	3			
Port "A"	100 ms. max.	25	25	25	✓		HPS
Port "B"		27	26	26	✓		HPS

Photo Taken   
Date 10/15/70

Comments: TOTAL CYCLES = 1830

Power, Valve at -65°F (Gaseous)

Power 28 Volts D. C. Steady State	Allowable	Act		O. K.	Reject	Initial
		A	B			
Voltage	28 ± .5	28.0	28.0	✓		HPS
Current	1.61 amps	1.43	1.4	✓		HPS
Power	45.0 watts max.	40.9	39.2	✓		HPS

Photo Taken   
Date 10/15/70

Comments: TOTAL CYCLES = 1832

Test Data Sheet  
 Pulse Operated Flow Diverter Valve  
 Specification 20M42517

Serial No. 007 Test Eng. RMR  
 Mech. Tech. RCO Q. C. Eng. C. G. G.  
 Elect. Tech. RCO TECH

5.8.3 After High and Low Temperature, Gaseous

Leakage After High and Low Temperature (Gaseous)

100% helium @ 50 ± 5 ppg Internal Press	Allowable	Actual	O. K.	Reject	Initial
	1.6 x 10 <sup>-6</sup> sccs	3.46 x 10 <sup>-8</sup>	✓		CBW

Date 10/19/70

Comments: TOTAL CYCLES = 2199

Port A Methanol/Water	Allowable	Actual			O. K.	Reject	Initial
		1	2	3			
5.0 ± .5 psig ΔP	0.20 sccs	0	0	0	✓		CBW
10.0 ± 1.0 psig ΔP	0.20 sccs	0	0	0	✓		CBW
20.0 ± 2.0 psig ΔP	0.20 sccs	0	0	0	✓		CBW

Date 10/19/70

Port B Methanol/Water	Allowable	Actual			O. K.	Reject	Initial
		1	2	3			
5.0 ± .5 psig ΔP	0.20 sccs	0	0	0	✓		CBW
10.0 ± 1.0 psig ΔP	0.20 sccs	0	0	0	✓		CBW
20.0 ± 2.0 psig ΔP	0.20 sccs	0	0	0	✓		CBW

Date 10/19/70

Comments: TOTAL CYCLES = 2116

**Pulse Operated Flow Diverter Valve  
Specification 20M42517**

Serial No. 008  
 Mech. Tech. RED  
 Elect. Tech. RED

Test Eng. RMR  
 Q. C. Eng. C. W. J.  
 Tech

**5.8.3 After High and Low Temperature, Gaseous**

Leakage After High and Low Temperature (Gaseous)

100% helium @ 50 ± 5 ppg Internal Press	Allowable	Actual	O. K.	Reject	Initial
	1.6 x 10 <sup>-6</sup> sccs	<del>3.46 x 10<sup>-8</sup></del> 11.25 x 10 <sup>-8</sup>	✓		CBW

Date 10/19/70

Comments: TOTAL CYCLES = 1840

Port A Methanol/Water	Allowable	Actual			O. K.	Reject	Initial
		1	2	3			
5.0 ± .5 psig ΔP	0.20 sccs	0	0	0	✓		CBW
10.0 ± 1.0 psig ΔP	0.20 sccs	0	0	0	✓		CBW
20.0 ± 2.0 psig ΔP	0.20 sccs	0	0	0	✓		CBW

Date 10/19/70

Port B Methanol/Water	Allowable	Actual			O. K.	Reject	Initial
		1	2	3			
5.0 ± .5 psig ΔP	0.20 sccs	0	0	0	✓		CBW
10.0 ± 1.0 psig ΔP	0.20 sccs	0	0	0	✓		CBW
20.0 ± 2.0 psig ΔP	0.20 sccs	0	0	0	✓		CBW

Date 10/19/70

Comments: TOTAL CYCLES = 1859

Pulse Operated Flow Diverter Valve  
Specification 20M42517

Serial No. 007  
 Mech. Tech. \_\_\_\_\_  
 Elect. Tech. REO

Test Eng. RMIR  
 Q. C. Eng. C. W. [Signature]  
 Tech. \_\_\_\_\_

Circuit Resistance After High and Low Temperature (Gaseous)

Port "A" Open Pins		Limit	Actual		
From	To		1	2	3
A	E	0.5 ohms max.	0.1	0.0	0.3
D	F	0.5 ohms max.	0.0	0.0	0.3
H	Case	0.5 ohms max.	0.0	0.0	0.0
L	J	25-29 ohms	27.5	27.3	27.6
B	E	Open Circuit	INF.	INF.	INF.
C	F	Open Circuit	INF.	INF.	INF.

Accept   
 Reject \_\_\_\_\_

Initial CBW  
 Date 10/19/70

Port "B" Open Pins		Limit	Actual		
From	To		1	2	3
A	E	Open Circuit	INF.	INF.	INF.
D	F	Open Circuit	INF.	INF.	INF.
H	Case	0.5 ohms max.	0.1	0.1	0.3
M	K	25-29 ohms	27.6	27.7	27.4
B	E	0.5 ohms max.	0.4	0.4	0.2
C	F	0.5 ohms max.	0.3	0.4	0.2

Accept   
 Reject \_\_\_\_\_

Initial CBW  
 Date 10/19/70

Comments: TOTAL CYCLES = 2123

Test Data Sheet  
Pulse Operated Flow Diverter Valve  
Specification 20M42517

Serial No. 008  
Mech. Tech. \_\_\_\_\_  
Elect. Tech. RED

Test Eng. RMP  
Q. C. Eng. C. My  
Tech \_\_\_\_\_

Circuit Resistance After High and Low Temperature (Gaseous)

Port "A" Open Pins		Limit	Actual		
From	To		1	2	3
A	E	0.5 ohms max.	0.1	0.1	0.1
D	F	0.5 ohms max.	0.1	0.1	0.1
H	Case	0.5 ohms max.	0.0	0.0	0.0
L	J	25-29 ohms	25.2	25.1	25.2
B	E	Open Circuit	INF	INF	INF
C	F	Open Circuit	INF	INF	INF

Accept   
Reject \_\_\_\_\_

Initial CRW  
Date 10/19/70

Port "B" Open Pins		Limit	Actual		
From	To		1	2	3
A	E	Open Circuit	INF	INF	INF
D	F	Open Circuit	INF	INF	INF
H	Case	0.5 ohms max.	0.0	0.0	0.2
M	K	25-29 ohms	25.1	25.0	25.7
B	E	0.5 ohms max.	0.0	0.3	0.4
C	F	0.5 ohms max.	0.0	0.2	0.4

Accept   
Reject \_\_\_\_\_

Initial CRW  
Date 10/19/70

Comments: TOTAL CYCLES = 1866

D-96



Test Data Sheet  
Pulse Operated Flow Diverter Valve  
Specification 20M42517

Serial No. 007  
Mech. Tech. \_\_\_\_\_  
Elect. Tech. RED

Test Eng. RMV  
Q. C. Eng. C. My  
TECH

357 (14)

Insulation Resistance After High and Low Temperature (Gaseous)

500 Volts D. C. Pins		Limit	Actual
From	To		
A	C	50 meg. ohms min.	750 MΩ
A	D	50 meg. ohms min.	
A	F	50 meg. ohms min.	
A	H	50 meg. ohms min.	
A	J	50 meg. ohms min.	
A	L	50 meg. ohms min.	
A	M	50 meg. ohms min.	
A	Case	50 meg. ohms min.	
B	C	50 meg. ohms min.	
B	D	50 meg. ohms min.	
B	F	50 meg. ohms min.	
B	A	50 meg. ohms min.	
B	J	50 meg. ohms min.	



Test Data Sheet  
Pulse Operated Flow Diverter Valve  
Specification 20M42517

Serial No. 007  
Mech. Tech. RED  
Elect. Tech. RED

Test Eng. RMR  
Q. C. Eng. C. Wy  
Test

Continued

From	To	Limit	Actual
B	K	50 meg. ohms min.	750 Meg
B	L	50 meg. ohms min.	
B	M	50 meg. ohms min.	
B	Case	50 meg. ohms min.	
C	E	50 meg. ohms min.	
C	H	50 meg. ohms min.	
C	J	50 meg. ohms min.	
C	K	50 meg. ohms min.	
C	L	50 meg. ohms min.	
C	M	50 meg. ohms min.	
C	Case	50 meg. ohms min.	
D	E	50 meg. ohms min.	
D	H	50 meg. ohms min.	
D	J	50 meg. ohms min.	
D	K	50 meg. ohms min.	
D	L	50 meg. ohms min.	
D	M	50 meg. ohms min.	
D	Case	50 meg. ohms min.	
E	F	50 meg. ohms min.	
E	H	50 meg. ohms min.	
E	J	50 meg. ohms min.	
E	K	50 meg. ohms min.	
E	L	50 meg. ohms min.	
E	M	50 meg. ohms min.	
E	Case	50 meg. ohms min.	
F	H	50 meg. ohms min.	
F	J	50 meg. ohms min.	
F	K	50 meg. ohms min.	
F	L	50 meg. ohms min.	
F	M	50 meg. ohms min.	
F	Case	50 meg. ohms min.	
G	A	50 meg. ohms min.	
G	B	50 meg. ohms min.	
G	C	50 meg. ohms min.	
G	D	50 meg. ohms min.	
G	E	50 meg. ohms min.	



Test Data Sheet  
Pulse Operated Flow Diverter Valve  
Specification 20M42517

Serial No. 007  
Mech. Tech. ✓  
Elect. Tech. ESS

Test Eng. RMR  
Q. C. Eng. C. Alley

Continued

From	To	Limit	Actual
G	F	50 meg. ohms min.	<i>&gt; 50 Meg</i> 
G	H	50 meg. ohms min.	
G	J	50 meg. ohms min.	
G	K	50 meg. ohms min.	
G	L	50 meg. ohms min.	
G	M	50 meg. ohms min.	
H	J	50 meg. ohms min.	
H	K	50 meg. ohms min.	
H	L	50 meg. ohms min.	
H	M	50 meg. ohms min.	
J	K	50 meg. ohms min.	
J	M	50 meg. ohms min.	
J	Case	50 meg. ohms min.	
K	L	50 meg. ohms min.	
K	Case	50 meg. ohms min.	
L	M	50 meg. ohms min.	
L	Case	50 meg. ohms min.	
M	Case	50 meg. ohms min.	

Accept ✓  
Reject \_\_\_\_\_

Initial CBW  
Date 10/19/70

Comments: \_\_\_\_\_

Port "A" Open 500 Volts D. C. Pins		Limit	Actual
From	To		
B	E	50 meg. ohms min.	<i>&gt; 50 Meg</i> 
B	A	50 meg. ohms min.	
C	D	50 meg. ohms min.	
C	F	50 meg. ohms min.	

Accept ✓  
Reject \_\_\_\_\_

Initial CBW  
Date 10/19/70



**Pulse Operated Flow Diverter Valve  
Specification 20M42517**

Serial No. 007  
 Mech. Tech. \_\_\_\_\_  
 Elect. Tech. REO

Test Eng. RMR  
 Q. C. Eng. C. My  
 Tech \_\_\_\_\_

Port "B" Open 500 Volts D. C. Pins		Limit	Actual
From	To		
A	B	50 meg. ohms min.	> 50 Meg ↓
A	E	50 meg. ohms min.	
D	C	50 meg. ohms min.	
D	F	50 meg. ohms min.	

Accept   
 Reject \_\_\_\_\_

Initial CBW  
 Date 10/19/70

Comments: TOTAL CYCLES = 2124

Position Indicators After High and Low Temperature (Gaseous)

Covered by Circuit Resistance Test.

Minimum Operating Voltage, After High and Low Temperature (Gaseous)

Minimum Operating Voltage 100 ms Pulse, Unpressurized	Allowable	Actual			O. K.	Reject	Initial
		1	2	3			
Port "A"	18 volts d.c. max.	16	16	16	✓		HR
Port "B"	18 volts d.c. max.	17	16	16	✓		HR

Date 10/20/70

Comments: TOTAL CYCLES = 2158

Minimum Operating Voltage 100ms Pulse 50 ± 5 psig, 100% Helium	Allowable	Actual			O. K.	Reject	Initial
		1	2	3			
Port "A"	18 volts d.c. max.	15	15	15	✓		HR
Port "B"	18 volts d.c. max.	15	15	15			HR

Date 10/20/70

Comments: TOTAL CYCLES = 2188

Serial No. 008  
 Mech. Tech.                       
 Elect. Tech. D20

Test Eng. RMR  
 Q. C. Eng. C. W. King

Port "B" Open 500 Volts D. C. Pins		Limit	Actual
From	To		
A	B	50 meg. ohms min.	> 50 MΩ ↓
A	E	50 meg. ohms min.	
D	C	50 meg. ohms min.	
D	F	50 meg. ohms min.	

Accept  Initial CBW  
 Reject  Date 10/19/70

Comments: TOTAL CYCLES = 1867

Position Indicators After High and Low Temperature (Gaseous)

Covered by Circuit Resistance Test.

Minimum Operating Voltage, After High and Low Temperature (Gaseous)

Minimum Operating Voltage 100 ms Pulse, Unpressurized	Allowable	Actual			O. K.	Reject	Ini
		1	2	3			
Port "A"	18 volts d. c. max.	15.5	15.5	15.0	✓		HT
Port "B"	18 volts d. c. max.	16.0	16.0	16.0	OK		WR

Date 20 OCT 70

Comments: TOTAL CYCLES = 1885

Minimum Operating Voltage 100ms Pulse 50 ± 5 psig, 100% Helium	Allowable	Actual			O. K.	Reject	Ini
		1	2	3			
Port "A"	18 volts d. c. max.	15.1	15.5	15	✓		CB
Port "B"	18 volts d. c. max.	15.5	15.0	15	✓		CB

Date 10/20/70

Comments: TOTAL CYCLES = 1907



Test Data Sheet  
Pulse Operated Flow Diverter Valve  
Specification 20M42517

Serial No. 007 Test Eng. RMR  
Mech. Tech.                      Q. C. Eng. PPG  
Elect. Tech. REO TEH

Pulse Duration, After High and Low Temperature (Gaseous)

Minimum Pulse Duration, 28 Volts D.C. 100% Helium, 50 ± 5 psig	Allowable	Actual			O.K.	Reject	Initial
		1	2	3			
Port "A"	100 ms. max.	29	26	27	✓		H124
Port "B"		27	27	26	✓		H124

Date 10/20/70

Comments: TOTAL CYCLES = 2218

Minimum Pulse Duration, 28 Volts D.C. Zero Press	Allowable	Actual			O.K.	Reject	Initial
		1	2	3			
Port "A"	100 ms. max.	26	25	25	✓		H124
Port "B"		29	28	28	✓		H124

Date 10/20/70

Comments: TOTAL CYCLES = 2247

Power, After High and Low Temperature (Gaseous)

Power 28 Volts D.C. Steady State	Allowable	Actual		O.K.	Reject	Initial
		A	B			
Voltage	28 ± .5	28.0	28.0	✓		CSW
Current	1.14 amps	.99	.93	✓		CSW
Power	31.5 watts max.	27.72	26.04	✓		CSW

Date 10/19/70

Comments: TOTAL CYCLES = 2244

Test Data Sheet  
Pulse Operated Flow Diverter Valve  
Specification 20M42517

Serial No. 008  
Mech. Tech.                       
Elect. Tech. DEO

Test Eng. RMR  
Q. C. Eng. CBW  
tech

Pulse Duration, After High and Low Temperature (Gaseous)

Minimum Pulse Duration, 28 Volts D. C. 100% Helium, 50 ± 5 psig	Allowable	Actual			O.K.	Reject	Initial
		1	2	3			
Port "A"	100 ms. max.	27	29	26	✓		CBW
Port "B"		26	28	26	✓		CBW

Date 10/20/70  
Comments: TOTAL CYCLES = 1925

Minimum Pulse Duration, 28 Volts D. C. Zero Press	Allowable	Actual			O.K.	Reject	Initial
		1	2	3			
Port "A"	100 ms. max.	27.5	30	28	✓		CBW
Port "B"		29.5	29	28	✓		CBW

Date                       
Comments: TOTAL CYCLES = 1949

Power, After High and Low Temperature (Gaseous)

Power 28 Volts D. C. Steady State	Allowable	Actual		O.K.	Reject	Initial
		A	B			
Voltage	28 ± .5	28.0	28.0	✓		CBW
Current	1.14 amps	1.07	1.06	✓		CBW
Power	31.5 watts max.	29.96	29.68	✓		CBW

Date 10/19/70  
Comments: TOTAL CYCLES = 1951

**Pulse Operated Flow Diverter Valve  
Specification 20M42517**

Serial No. 607  
 Mech. Tech. REO  
 Elect. Tech. REO

Test Eng. RMR  
 Q. C. Eng. H. F. CARPENITO

**5.8.4. High Temperature, Liquid**

Leakage, Valve at +100°F (Liquid)

Port A Methanol/Water	Allowable	Actual			O. K.	Reject	Initial
		1	2	3			
5.0 ± .5 psig ΔP	0.20 ccs	0.0	0.0	0.0	✓		HFC
10.0 ± 1.0 psig ΔP	0.20 ccs	0.0	0.0	0.0	✓		HFC
20.0 ± 2.0 psig ΔP	0.20 ccs	0.0	0.0	0.0	✓		HFC

Date 10/21/70

Comments: TOTAL CYCLES = 2253

Port B Methanol/Water	Allowable	Actual			O. K.	Reject	Initial
		1	2	3			
5.0 ± .5 psig ΔP	0.20 ccs	0.0	0.0	0.0	✓		HFC
10.0 ± 1.0 psig ΔP	0.20 ccs	0.0	0.0	0.0	✓		HFC
20.0 ± 2.0 psig ΔP	0.20 ccs	0.0	0.0	0.0	✓		HFC

Date 10/21/70

Comments: TOTAL CYCLES = 2265

Circuit Resistance, Valve at +100°F (Liquid)

Port "A" Open Pins From To	Limit	Actual		
		1	2	3
A E	0.5 ohms max.	0.2	0.2	0.4
D F	0.5 ohms max.	0.3	0.3	0.4
H Case	0.5 ohms max.	0.4	0.3	0.4
L J	—	29.3	29.3	29.4
B E	Open Circuit	OPEN	OPEN	OPEN
C F	Open Circuit	OPEN	OPEN	OPEN

Accept ✓

Reject \_\_\_\_\_

Initial H.F.C.

Date 10/21/70

Pulse Operated Flow Diverter Valve  
Specification 20M42517

Serial No. 008  
 Mech. Tech. REO  
 Elect. Tech. REO

Test Eng. RMR  
 Q. C. Eng. H. F. Capparuto

5.8.4. High Temperature, Liquid

Leakage, Valve at +100°F (Liquid)

Port A Methanol/Water	Allowable	Actual			O. K.	Reject	Initial
		1	2	3			
5.0 ± .5 psig ΔP	0.20 ccs	0.0	0.0	0.0	✓		H.F.C.
10.0 ± 1.0 psig ΔP	0.20 ccs	0.0	0.0	0.0	✓		H.F.C.
20.0 ± 2.0 psig ΔP	0.20 ccs	0.0	0.0	0.0	✓		H.F.C.

Date 10/21/70

Comments: TOTAL CYCLES = 1963

Port B Methanol/Water	Allowable	Actual			O. K.	Reject	Initial
		1	2	3			
5.0 ± .5 psig ΔP	0.20 ccs	0.0	0.0	0.0	✓		H.F.C.
10.0 ± 1.0 psig ΔP	0.20 ccs	0.0	0.0	0.0	✓		H.F.C.
20.0 ± 2.0 psig ΔP	0.20 ccs	0.0	0.0	0.0	✓		H.F.C.

Date 10/21/70

Comments: TOTAL CYCLES = 1972

Circuit Resistance, Valve at +100°F (Liquid)

Port "A" Open Pins		Limit	Actual		
From	To		1	2	3
A	E	0.5 ohms max.	0.4	0.4	0.4
D	F	0.5 ohms max.	0.4	0.4	0.4
H	Case	0.5 ohms max.	0.2	0.3	0.4
L	J		26.9	26.9	26.9
B	E	Open Circuit	OPEN	OPEN	OPEN
C	F	Open Circuit	OPEN	OPEN	OPEN

Accept ✓  
 Reject \_\_\_\_\_

Initial H.F.C.  
 Date 10/21/70

Test Data Sheet  
 Pulse Operated Flow Diverter Valve  
 Specification 20M42517

Serial No. 007  
 Mech. Tech.                       
 Elect. Tech. REC

Test Eng. RMR  
 Q. C. Eng. H. F. CARPENITO

Port "B" Open Pins		Limit	Actual		
From	To		1	2	3
A	E	Open Circuit	OPEN	OPEN	OPEN
D	F	Open Circuit	OPEN	OPEN	OPEN
H	Case	0.5 ohms max.	0.4	0.4	0.3
M	K		29.4	29.4	29.3
B	E	0.5 ohms max.	0.4	0.4	0.4
C	F	0.5 ohms max.	0.4	0.4	0.3

Accept                     ✓                      
 Reject                     

Initial H. F. C.  
 Date 10/21/70

Comments: TOTAL CYCLES = 22.72

Insulation Resistance, Valve at +100°F (Liquid)

500 Volts D. C. Pins		Limit	Actual
From	To		
A	C	50 meg. ohms min.	↗ 50 MEG ↑ ↓ ↘ 50 MEG
A	D	50 meg. ohms min.	
A	F	50 meg. ohms min.	
A	H	50 meg. ohms min.	
A	J	50 meg. ohms min.	
A	L	50 meg. ohms min.	
A	M	50 meg. ohms min.	
A	Case	50 meg. ohms min.	
B	C	50 meg. ohms min.	
B	D	50 meg. ohms min.	
B	F	50 meg. ohms min.	
B	A	50 meg. ohms min.	
B	J	50 meg. ohms min.	

Test Data Sheet  
Pulse Operated Flow Diverter Valve  
Specification 20M42517

Serial No. 008  
Mech. Tech. \_\_\_\_\_  
Elect. Tech. PEO

Test Eng. RMF  
Q. C. Eng. H. F. CARPENTO

Port "B" Open Pins		Limit	Actual		
From	To		1	2	3
A	E	Open Circuit	OPEN	OPEN	OPEN
D	F	Open Circuit	OPEN	OPEN	OPEN
H	Case	0.5 ohms max.	0.3	0.3	0.5
M	K	_____	26.9	26.9	25.9
B	E	0.5 ohms max.	0.4	0.4	0.4
C	F	0.5 ohms max.	0.4	0.4	0.4

Accept   
Reject \_\_\_\_\_

Initial H. F. C.  
Date 10/21/70

Comments: TOTAL CYCLES = 1779

Insulation Resistance, Valve at +100°F (Liquid)

500 Volts D. C. Pins		Limit	Actual
From	To		
A	C	50 meg. ohms min.	<u>&gt; 50 MΩ</u> ↑ ↓ <u>&gt; 50 MΩ</u>
A	D	50 meg. ohms min.	
A	F	50 meg. ohms min.	
A	H	50 meg. ohms min.	
A	J	50 meg. ohms min.	
A	L	50 meg. ohms min.	
A	M	50 meg. ohms min.	
A	Case	50 meg. ohms min.	
B	C	50 meg. ohms min.	
B	D	50 meg. ohms min.	
B	F	50 meg. ohms min.	
B	A	50 meg. ohms min.	
B	J	50 meg. ohms min.	

Test Data Sheet  
Pulse Operated Flow Diverter Valve  
Specification 20M42517

Serial No. 007 Test Eng. RMR  
Mech. Tech.                      Q. C. Eng. H. F. Carpenito  
Elect. Tech. REO

Continued

From	To	Limit	Actual
B	K	50 meg. ohms min.	> 50 MEG
B	L	50 meg. ohms min.	↑
B	M	50 meg. ohms min.	
B	Case	50 meg. ohms min.	
C	E	50 meg. ohms min.	
C	H	50 meg. ohms min.	
C	J	50 meg. ohms min.	
C	K	50 meg. ohms min.	
C	L	50 meg. ohms min.	
C	M	50 meg. ohms min.	
C	Case	50 meg. ohms min.	
D	E	50 meg. ohms min.	
D	H	50 meg. ohms min.	
D	J	50 meg. ohms min.	
D	K	50 meg. ohms min.	
D	L	50 meg. ohms min.	
D	M	50 meg. ohms min.	
D	Case	50 meg. ohms min.	
E	F	50 meg. ohms min.	
E	H	50 meg. ohms min.	
E	J	50 meg. ohms min.	
E	K	50 meg. ohms min.	
E	L	50 meg. ohms min.	
E	M	50 meg. ohms min.	
E	Case	50 meg. ohms min.	
F	H	50 meg. ohms min.	
F	J	50 meg. ohms min.	
F	K	50 meg. ohms min.	
F	L	50 meg. ohms min.	
F	M	50 meg. ohms min.	
F	Case	50 meg. ohms min.	
G	A	50 meg. ohms min.	
G	B	50 meg. ohms min.	
G	C	50 meg. ohms min.	
G	D	50 meg. ohms min.	
G	E	50 meg. ohms min.	> 50 MEG

Test Data Sheet

Pulse Operated Flow Diverter Valve  
Specification 20M42517

Serial No. 008  
 Mech. Tech. \_\_\_\_\_  
 Elect. Tech. leo

Test Eng. RMR  
 Q. C. Eng. H.F. CARPENTE

Continued

From	To	Limit	Actual
B	K	50 meg. ohms min.	> 50 meg.
B	L	50 meg. ohms min.	
B	M	50 meg. ohms min.	
B	Case	50 meg. ohms min.	
C	E	50 meg. ohms min.	
C	H	50 meg. ohms min.	
C	J	50 meg. ohms min.	
C	K	50 meg. ohms min.	
C	L	50 meg. ohms min.	
C	M	50 meg. ohms min.	
C	Case	50 meg. ohms min.	
D	E	50 meg. ohms min.	
D	H	50 meg. ohms min.	
D	J	50 meg. ohms min.	
D	K	50 meg. ohms min.	
D	L	50 meg. ohms min.	
D	M	50 meg. ohms min.	
D	Case	50 meg. ohms min.	
E	F	50 meg. ohms min.	
E	H	50 meg. ohms min.	
E	J	50 meg. ohms min.	
E	K	50 meg. ohms min.	
E	L	50 meg. ohms min.	
E	M	50 meg. ohms min.	
E	Case	50 meg. ohms min.	
F	H	50 meg. ohms min.	
F	J	50 meg. ohms min.	
F	K	50 meg. ohms min.	
F	L	50 meg. ohms min.	
F	M	50 meg. ohms min.	
F	Case	50 meg. ohms min.	
G	A	50 meg. ohms min.	
G	B	50 meg. ohms min.	
G	C	50 meg. ohms min.	
G	D	50 meg. ohms min.	
G	E	50 meg. ohms min.	> 50 meg.





Test Data Sheet  
Pulse Operated Flow Diverter Valve  
Specification 20M42517

Serial No. 008 Test Eng. RMR  
Mech. Tech. ✓ Q. C. Eng. H. F. CARRENITO  
Elect. Tech. REO

Continued

From	To	Limit	Actual
G	F	50 meg. ohms min.	> 50 MEG
G	H	50 meg. ohms min.	↑ ↓
G	J	50 meg. ohms min.	
G	K	50 meg. ohms min.	
G	L	50 meg. ohms min.	
G	M	50 meg. ohms min.	
H	J	50 meg. ohms min.	
H	K	50 meg. ohms min.	
H	L	50 meg. ohms min.	
H	M	50 meg. ohms min.	
J	K	50 meg. ohms min.	
J	M	50 meg. ohms min.	80 MEG
J	Case	50 meg. ohms min.	60 MEG
K	L	50 meg. ohms min.	> 50 MEG
K	Case	50 meg. ohms min.	> 50 MEG
L	M	50 meg. ohms min.	70 MEG
L	Case	50 meg. ohms min.	> 50 MEG
M	Case	50 meg. ohms min.	> 50 MEG

Accept ✓  
Reject \_\_\_\_\_

Initial H.F.C.  
Date 10/21/70

Comments: \_\_\_\_\_

Port "A" Open 500 Volts D. C. Pins			
From	To	Limit	Actual
B	E	50 meg. ohms min.	> 50 MEG
B	A	50 meg. ohms min.	↑ ↓
C	D	50 meg. ohms min.	
C	F	50 meg. ohms min.	

Accept ✓  
Reject \_\_\_\_\_

Initial H.F.C.  
Date 10/21/70

**Pulse Operated Flow Diverter Valve  
Specification 20M42517**

Serial No. 007  
 Mech. Tech.                       
 Elect. Tech. RED

Test Eng. RMR  
 Q. C. Eng. H. F. CARPENTIER

Port "B" Open 500 Volts D. C. Pins		Limit	Actual
From	To		
A	B	50 meg. ohms min.	> 50MΩ
A	E	50 meg. ohms min.	↕
D	C	50 meg. ohms min.	
D	F	50 meg. ohms min.	> 50MΩ

Accept   
 Reject

Initial H.F.C.  
 Date 10/21/70

Comments: TOTAL CYCLES = 2273

Position Indicators, Valve at +100°F (Liquid)

Covered by Circuit Resistance Test.

Minimum Voltage, Valve at +100°F (Liquid)

Minimum Operating Voltage 100 ms Pulse, Unpressurized	Allowable	Actual			O. K.	Reject	Initial
		1	2	3			
Port "A"	18 volts d. c. max.	17	17	16	✓		HFC
Port "B"	18 volts d. c. max.	18	17.5	18	✓		HFC

Date 10/22/70

Comments: TOTAL CYCLES = 2301

Minimum Operating Voltage 100ms Pulse 50 ± 5 psig, 100% Helium	Allowable	Actual			O. K.	Reject	Initial
		1	2	3			
Port "A"	18 volts d. c. max.	16.5	16.5	16.0	✓		HFC
Port "B"	18 volts d. c. max.	17.5	17.5	17.5	✓		HFC

Date 10/22/70

Comments: TOTAL CYCLES = 2325

Specification 20M42517

Serial No. 005  
 Mech. Tech.                       
 Elect. Tech. RED

Test Eng. RMR  
 Q. C. Eng. H.F. CARPENTO

Port "B" Open 500 Volts D. C. Pins		Limit	Actual
From	To		
A	B	50 meg. ohms min.	> 50 MEG ↑ ↓ > 50 MEG
A	E	50 meg. ohms min.	
D	C	50 meg. ohms min.	
D	F	50 meg. ohms min.	

Accept   
 Reject

Initial H.F.C.  
 Date 10/21/70

Comments: TOTAL CYCLES = 1981

Position Indicators, Valve at +100°F (Liquid)

Covered by Circuit Resistance Test.

Minimum Voltage, Valve at +100°F (Liquid)

Minimum Operating Voltage 100 ms Pulse, Unpressurized	Allowable	Actual			O. K.	Reject	Initial
		1	2	3			
Port "A"	18 volts d.c. max.	17.5	17.5	17.0	✓		H.F.C.
Port "B"	18 volts d.c. max.	17.5	17.5	17.9	✓		H.F.C.

Date 10/20/70

Comments: TOTAL CYCLES = 2011

Minimum Operating Voltage 100ms Pulse 50 ± 5 psig, 100% Helium	Allowable	Actual			O. K.	Reject	Initial
		1	2	3			
Port "A"	18 volts d.c. max.	17.5	17.5	17.9	✓		H.F.C.
Port "B"	18 volts d.c. max.	17.5	17.5	17.5	✓		H.F.C.

Date 10/23/70

Comments: TOTAL CYCLES = 2040

Test Data Sheet  
Pulse Operated Flow Diverter Valve  
Specification 20M42517

Serial No. 007 Test Eng. RMR  
Mech. Tech.                      Q. C. Eng. PPG/AFR  
Elect. Tech. REO TECH

Pulse Duration, Valve at +100°F (Liquid)

Minimum Pulse Duration, 28 Volts D. C. 100% Helium, 50 ± 5 psig	Allowable	Actual			O. K.	Reject	Initial
		1	2	3			
Port "A"	100 ms. max.	29	29	29	✓		H24
Port "B"		34	34	34	✓		H24

Photo Taken 10/22/70  
Date                     

Comments: TOTAL CYCLES = 2345

Minimum Pulse Duration, 28 Volts D. C. Zero Press	Allowable	Actual			O. K.	Reject	Initial
		1	2	3			
Port "A"	100 ms. max.	27	27	26.5	✓		H24
Port "B"		28	28	28	✓		H24

Photo Taken 10/22/70  
Date                     

Comments: TOTAL CYCLES = 2367

Power, Valve at +100°F (Liquid)

Power 28 Volts D. C. Steady State	Allowable	A	B	O. K.	Reject	Initial
		Actual	Actual			
Voltage	28 ± .5	28.0	28.0	✓		H24
Current	1.14 amps	0.94	0.93	✓		H24
Power	31.5 watts max.	26.4	26.4	✓		H24

Date 10/21/70

Comments: TOTAL CYCLES = 2368

Test Data Sheet  
Pulse Operated Flow Diverter Valve  
Specification 20M42517

Serial No. 608 Test Eng. RMR  
Mech. Tech. REO Q. C. Eng. HFG/HRC  
Elect. Tech. REO JEL

Pulse Duration, Valve at +100°F (Liquid)

Minimum Pulse Duration, 28 Volts D.C. 100% Helium, 50 ± 5 psig	Allowable	Actual			O.K.	Reject	Initial
		1	2	3			
Port "A"	100 ms. max.	30	32	30	✓		H.F.C.
Port "B"		32	33	33	✓		H.F.C.

Photo Taken   
Date 10/22/70

Comments: TOTAL CYCLES = 2064

Minimum Pulse Duration, 28 Volts D.C. Zero Press	Allowable	Actual			O.K.	Reject	Initial
		1	2	3			
Port "A"	100 ms. max.	31	32	31	✓		H.F.C.
Port "B"		32	33	34	✓		H.F.C.

Photo Taken   
Date 10/27/70

Comments: TOTAL CYCLES = 2090

Power, Valve at +100°F (Liquid)

Power 28 Volts D.C. Steady State	Allowable	A B		O.K.	Reject	Initial
		Actual				
Voltage	28 ± .5	28.0	28.0	✓		H.F.C.
Current	1.14 amps	1.03	1.03	✓		H.F.C.
Power	31.5 watts max.	28.5	27.5	✓		H.F.C.

Date 10/21/70

Comments: TOTAL CYCLES = 2091

**Pulse Operated Flow Diverter Valve  
Specification 20M42517**

Serial No. 007 Test Eng. EMR  
 Mech. Tech. RED Q. C. Eng. C. My  
 Elect. Tech. RED Tech

**5.8.5 Low Temperature Liquid**

Leakage, Valve at -65°F (Liquid)

Port A Methanol/Water	Allowable	Actual			O. K.	Reject	Initial
		1	2	3			
5.0 ± .5 psig ΔP	0.20 ccs	0	0	0	✓		CBW
10.0 ± 1.0 psig ΔP	0.20 ccs	0	0	0	✓		CBW
20.0 ± 2.0 psig ΔP	0.20 ccs	0	0	0	✓		CBW

Date

10/26/70

Comments: TOTAL CYCLES = 2377

Port B Methanol/Water	Allowable	Actual			O. K.	Reject	Initial
		1	2	3			
5.0 ± .5 psig ΔP	0.20 ccs	0	0	0	✓		CBW
10.0 ± 1.0 psig ΔP	0.20 ccs	0	0	0	✓		CBW
20.0 ± 2.0 psig ΔP	0.20 ccs	0	0	0	✓		CBW

Date

10/26/70

Comments: TOTAL CYCLES = 2385

Circuit Resistance, Valve at -65°F (Liquid)

Port "A" Open Pins		Limit	Actual		
From	To		1	2	3
A	E	0.5 ohms max.	0.0	0.0	0.0
D	F	0.5 ohms max.	0.0	0.0	0.0
H	Case	0.5 ohms max.	0.0	0.0	0.0
L	J	17.2 ohms min.	19.6	19.6	19.6
B	E	Open Circuit	INF	INF	INF
C	F	Open Circuit	INF	INF	INF

Accept ✓

Reject \_\_\_\_\_

Initial CBW

Date 10/27/70

Serial No. 008  
 Mech. Tech. RSD  
 Elect. Tech. RSD

Test Eng. RMR  
 Q. C. Eng. C. W. King  
*Accept*

5.8.5 Low Temperature Liquid

Leakage, Valve at -65°F (Liquid)

Port A Methanol/Water	Allowable	Actual			O. K.	Reject	Initial
		1	2	3			
5.0 ± .5 psig ΔP	0.20 ccs	0	0	0	✓		CBW
10.0 ± 1.0 psig ΔP	0.20 ccs	0	0	0	✓		CBW
20.0 ± 2.0 psig ΔP	0.20 ccs	0	0	0	✓		CBW



Date 10/27/70

Comments: TOTAL CYCLES = 2101

Port B Methanol/Water	Allowable	Actual			O.K.	Reject	Initial
		1	2	3			
5.0 ± .5 psig ΔP	0.20 ccs	0	0	0	✓		CBW
10.0 ± 1.0 psig ΔP	0.20 ccs	0	0	0	✓		CBW
20.0 ± 2.0 psig ΔP	0.20 ccs	0	0	0	✓		CBW



Date 10/27/70

Comments: TOTAL CYCLES = 2111

Circuit Resistance, Valve at -65°F (Liquid)

Port "A" Open Pins		Limit	Actual		
From	To		1	2	3
A	E	0.5 ohms max.	0	.1	.1
D	F	0.5 ohms max.	0	.1	.1
H	Case	0.5 ohms max.	0	0	0
L	J	17.2 ohms min.	18.2	18.3	18.4
B	E	Open Circuit	INF	INF	INF
C	F	Open Circuit	INF	INF	INF



Accept ✓  
 Reject \_\_\_\_\_

Initial CBW  
 Date 10/24/70



**Test Data Sheet**  
**Pulse Operated Flow Diverter Valve**  
**Specification 20M42517**

Serial No. 007 Test Eng. RMVZ  
 Mech. Tech.                      Q. C. Eng. CBW  
 Elect. Tech. DEO TECH

Port "B" Open Pins		Limit	Actual		
From	To		1	2	3
A	E	Open Circuit	INF	INF	INF
D	F	Open Circuit	INF	INF	INF
H	Case	0.5 ohms max.	0.0	0	0
M	K	17.2 ohms min.	19.6	19.6	19.6
B	E	0.5 ohms max.	0.0	0	0
C	F	0.5 ohms max.	0.0	0	0

Accept  Initial CBW  
 Reject  Date 10/27/70

Comments: TOTAL CYCLES = 2387

Insulation Resistance, Valve at -65°F (Liquid)

500 Volts D. C. Pins		Limit	Actual
From	To		
A	C	50 meg. ohms min.	> 50 MEG 
A	D	50 meg. ohms min.	
A	F	50 meg. ohms min.	
A	H	50 meg. ohms min.	
A	J	50 meg. ohms min.	
A	L	50 meg. ohms min.	
A	M	50 meg. ohms min.	
A	Case	50 meg. ohms min.	
B	C	50 meg. ohms min.	
B	D	50 meg. ohms min.	
B	F	50 meg. ohms min.	
B	A	50 meg. ohms min.	
B	J	50 meg. ohms min.	

Test Data Sheet  
Pulse Operated Flow Diverter Valve  
Specification 20M42517

Serial No. 008 Test Eng. RMR  
Mech. Tech. \_\_\_\_\_ Q. C. Eng. CEW  
Elect. Tech. REO TECH

Port "B" Open Pins		Limit	Actual		
From	To		1	2	3
A	E	Open Circuit	INF	INF	INF
D	F	Open Circuit	INF	INF	INF
H	Case	0.5 ohms max.	.1	.4	.3
M	K	17.2 ohms min.	18.7	18.5	19.1
B	E	0.5 ohms max.	.1	.3	.4
C	F	0.5 ohms max.	.2	.2	.4



Accept ✓ Initial CEW  
Reject \_\_\_\_\_ Date 10/26/

Comments: TOTAL CYCLES = 2114

Insulation Resistance, Valve at -65°F (Liquid)

500 Volts D. C. Pins		Limit	Actual
From	To		
A	C	50 meg. ohms min.	<u>&gt; 50 MEG</u> 
A	D	50 meg. ohms min.	
A	F	50 meg. ohms min.	
A	H	50 meg. ohms min.	
A	J	50 meg. ohms min.	
A	L	50 meg. ohms min.	
A	M	50 meg. ohms min.	
A	Case	50 meg. ohms min.	
B	C	50 meg. ohms min.	
B	D	50 meg. ohms min.	
B	F	50 meg. ohms min.	
B	A	50 meg. ohms min.	
B	J	50 meg. ohms min.	



Test Data Sheet

Pulse Operated Flow Diverter Valve  
Specification 20M42517

Serial No. \_\_\_\_\_  
Mech. Tech. \_\_\_\_\_  
Elect. Tech. \_\_\_\_\_

Test Eng. \_\_\_\_\_  
Q. C. Eng. \_\_\_\_\_  
TECH \_\_\_\_\_

008  
\_\_\_\_\_  
RED

RMR  
\_\_\_\_\_  
CBW

Continued

From	To	Limit	Actual
B	K	50 meg. ohms min.	750 MEG ↓
B	L	50 meg. ohms min.	
B	M	50 meg. ohms min.	
B	Case	50 meg. ohms min.	
C	E	50 meg. ohms min.	
C	H	50 meg. ohms min.	
C	J	50 meg. ohms min.	
C	K	50 meg. ohms min.	
C	L	50 meg. ohms min.	
C	M	50 meg. ohms min.	
C	Case	50 meg. ohms min.	
D	E	50 meg. ohms min.	
D	H	50 meg. ohms min.	
D	J	50 meg. ohms min.	
D	K	50 meg. ohms min.	
D	L	50 meg. ohms min.	
D	M	50 meg. ohms min.	
D	Case	50 meg. ohms min.	
E	F	50 meg. ohms min.	
E	H	50 meg. ohms min.	
E	J	50 meg. ohms min.	
E	K	50 meg. ohms min.	
E	L	50 meg. ohms min.	
E	M	50 meg. ohms min.	
E	Case	50 meg. ohms min.	
F	H	50 meg. ohms min.	
F	J	50 meg. ohms min.	
F	K	50 meg. ohms min.	
F	L	50 meg. ohms min.	
F	M	50 meg. ohms min.	
F	Case	50 meg. ohms min.	
G	A	50 meg. ohms min.	
G	B	50 meg. ohms min.	
G	C	50 meg. ohms min.	
G	D	50 meg. ohms min.	
G	E	50 meg. ohms min.	



Test Data Sheet  
Pulse Operated Flow Diverter Valve  
Specification 20M42517

Serial No. 008 Test Eng. RMR  
Mech. Tech. \_\_\_\_\_ Q. C. Eng. CBW  
Elect. Tech. RED Tech

Continued

From	To	Limit	Actual
G	F	50 meg. ohms min.	750 MEG ↓
G	H	50 meg. ohms min.	
G	J	50 meg. ohms min.	
G	K	50 meg. ohms min.	
G	L	50 meg. ohms min.	
G	M	50 meg. ohms min.	
H	J	50 meg. ohms min.	
H	K	50 meg. ohms min.	
H	L	50 meg. ohms min.	
H	M	50 meg. ohms min.	
J	K	50 meg. ohms min.	
J	M	50 meg. ohms min.	
J	Case	50 meg. ohms min.	
K	L	50 meg. ohms min.	
K	Case	50 meg. ohms min.	
L	M	50 meg. ohms min.	
L	Case	50 meg. ohms min.	
M	Case	50 meg. ohms min.	

Accept ✓  
Reject \_\_\_\_\_

Initial CBW  
Date 10/26/70

Comments: \_\_\_\_\_

Port "A" Open 500 Volts D. C. Pins		Limit	Actual
From	To		
B	E	50 meg. ohms min.	750 MEG ↓
B	A	50 meg. ohms min.	
C	D	50 meg. ohms min.	
C	F	50 meg. ohms min.	

Accept ✓  
Reject \_\_\_\_\_

Initial CBW  
Date 10/26/70

Specification 20M42517

Serial No. 007  
 Mech. Tech. \_\_\_\_\_  
 Elect. Tech. RED

Test Eng. RHR  
 Q. C. Eng. C. J. King  
 Tech \_\_\_\_\_

Port "B" Open 500 Volts D. C. Pins		Limit	Actual
From	To		
A	B	50 meg. ohms min.	<u>750 MEG</u>
A	E	50 meg. ohms min.	
D	C	50 meg. ohms min.	
D	F	50 meg. ohms min.	

Accept V Initial CBW  
 Reject \_\_\_\_\_ Date 10/27/70

Comments: TOTAL CYCLES = 2388

Position Indicators, Valve at -65°F (Liquid)

Covered by Circuit Resistance Test.

Minimum Voltage, Valve at -65°F (Liquid)

Minimum Operating Voltage 100 ms Pulse, Unpressurized	Allowable	Actual			O. K.	Reject	Init
		1	2	3			
Port "A"	18 volts d. c. max.	<u>15</u>	<u>12</u>	<u>13</u>	<u>V</u>		<u>CBW</u>
Port "B"	18 volts d. c. max.	<u>14</u>	<u>13</u>	<u>13</u>	<u>V</u>		<u>CBW</u>

Date 10/23/70 P.F. T.P.C. 10/23/70

Comments: TOTAL CYCLES = 2412

Minimum Operating Voltage 100 ms Pulse 50 ± 5 psig, 100% Helium	Allowable	Actual			O. K.	Reject	Init
		1	2	3			
Port "A"	18 volts d. c. max.	<u>13</u>	<u>12</u>	<u>12</u>	<u>V</u>		<u>CBW</u>
Port "B"	18 volts d. c. max.	<u>13.5</u>	<u>14</u>	<u>14</u>	<u>V</u>		<u>CBW</u>

Date 10/23/70 P.F. T.P.C. 10/23/70

Comments: TOTAL CYCLES = 2437

Serial No. 008  
 Mech. Tech. \_\_\_\_\_  
 Elect. Tech. REO

Test Eng. RMR  
 Q. C. Eng. C. Wy  
 Tech \_\_\_\_\_

Port "B" Open 500 Volts D. C. Pins		Limit	Actual
From	To		
A	B	50 meg. ohms min.	750 MEG
A	E	50 meg. ohms min.	
D	C	50 meg. ohms min.	
D	F	50 meg. ohms min.	

Accept   
 Reject \_\_\_\_\_

Initial CBW  
 Date 10/26/70

Comments: TOTAL CYCLES = 2115

Position Indicators, Valve at -65°F (Liquid)

Covered by Circuit Resistance Test.

Minimum Voltage, Valve at -65°F (Liquid)

Minimum Operating Voltage 100 ms Pulse, Unpressurized	Allowable	Actual			O. K.	Reject	Initi
		1	2	3			
Port "A"	18 volts d. c. max.	12	11	11	✓		CBW
Port "B"	18 volts d. c. max.	11	12	11	✓		CBW

Date 10/23/70

Comments: TOTAL CYCLES = 2141

Minimum Operating Voltage 100 ms Pulse 50 ± 5 psig, 100% Helium	Allowable	Actual			O. K.	Reject	Initi
		1	2	3			
Port "A"	18 volts d. c. max.	12.5	12	12.5	✓		CBW
Port "B"	18 volts d. c. max.	12	13	12	✓		CBW

Date 10/23/70

Comments: TOTAL CYCLES = 2161



Test Data Sheet  
Pulse Operated Flow Diverter Valve  
Specification 20M42517

Serial No. 007 Test Eng. RMR  
Mech. Tech. — Q. C. Eng. CPW  
Elect. Tech. REO TECA

Pulse Duration, Valve at -65°F (Liquid)

Minimum Pulse Duration, 28 Volts D. C. 100% Helium, 50 ± 5 psig	Allowable	Actual			O.K.	Reject	Initial
		1	2	3			
Port "A"	100 ms. max.	32	31	31	✓		CPW
Port "B"		37	37	37	✓		CPW

Date 10/22/70  A.F. TPC 10/27

Comments: TOTAL CYCLES = 2460



Minimum Pulse Duration, 28 Volts D. C. Zero Press	Allowable	Actual			O.K.	Reject	Initial
		1	2	3			
Port "A"	100 ms. max.	30	29	27	✓		CPW
Port "B"		27	27	27	✓		CPW

Date 10/23/70  A.F. TPC 10/27

Comments: TOTAL CYCLES = 2480

Power, Valve at -65°F (Liquid)

Power 28 Volts D. C. Steady State	Allowable	Actual		O.K.	Reject	Initial
		A	B			
Voltage	28 ± .5	27.8	27.8	✓		CPW
Current	1.61 amps max.	1.35	1.33	✓		CPW
Power	45.0 watts max.	37.5	36.9	✓		CPW

Date 10/27/70  

Comments: TOTAL CYCLES = 2491

Test Data Sheet  
 Pulse Operated Flow Diverter Valve  
 Specification 20M42517

Serial No. 008 Test Eng. RMR  
 Mech. Tech.                      Q. C. Eng. C. W. J.  
 Elect. Tech. REO Tech

Pulse Duration, Valve at -65°F (Liquid)

Minimum Pulse Duration, 28 Volts D. C. 100% Helium, 50 ± 5 psig	Allowable	Actual			O.K.	Reject	Initial
		1	2	3			
Port "A"	100 ms. max.	32	31	30	✓		CBW
Port "B"		31	33	31	✓		CBW

Date 10/23/70

Comments: TOTAL CYCLES = 2187

Minimum Pulse Duration, 28 Volts D. C. Zero Press	Allowable	Actual			O.K.	Reject	Initial
		1	2	3			
Port "A"	100 ms. max.	27	28	26	✓		CBW
Port "B"		26	28	28	✓		CBW

Date 10/23/70

Comments: TOTAL CYCLES = 2227

Power, Valve at -65°F (Liquid)

Power 28 Volts D. C. Steady State	Allowable	A	B	O.K.	Reject	Initial
		Actual				
Voltage	28 ± .5	28.0	28.0	✓		CBW
Current	1.61 amps max.	1.45	1.43	✓		CBW
Power	45.0watts max.	40.6	40.3	✓		CBW

Date 10/26/70

Comments: TOTAL CYCLES = 2228

**Pulse Operated Flow Diverter Valve  
Specification 20M42517**

Serial No. 007 Test Eng. RMP  
 Mech. Tech. PEO Q. C. Eng. HPG  
 Elect. Tech. RSD TECA

**5.8.6 After High and Low Temperature, Liquid**

Leakage, After High and Low Temperature, Liquid

100% helium @ 50 ± 5 pgg	Allowable	Actual	O. K.	Reject	Initial
Internal Press	$1.6 \times 10^{-6}$ sccs	$1.69 \times 10^{-7}$	✓		HPG

Date \_\_\_\_\_

Comments: STD LEAK RATE =  $1.3 \times 10^{-8}$   
STD LEAK READING = 2.6 VALVE LEAK READING = 34.0  
TOTAL CYCLES = 2485

Port A Methanol/Water	Allowable	Actual			O. K.	Reject	Initial
		1	2	3			
5.0 ± .5 psig ΔP	0.20 sccs	.001	.005	.003	✓		HPG
10.0 ± 1.0 psig ΔP	0.20 sccs	.001	.01	.003	✓		HPG
20.0 ± 2.0 psig ΔP	0.20 sccs	.001	.02	.006	✓		HPG

Date 10-29-70

Port B Methanol/Water	Allowable	Actual			O. K.	Reject	Initial
		1	2	3			
5.0 ± .5 psig ΔP	0.20 sccs	0	0	0	✓		HPG
10.0 ± 1.0 psig ΔP	0.20 sccs	0	0	0	✓		HPG
20.0 ± 2.0 psig ΔP	0.20 sccs	0	0	0	✓		HPG

Date 10-29-70

Comments: TOTAL CYCLES = 2507

Serial No. 008 Test Eng. RMR  
 Mech. Tech. RED Q. C. Eng. APG  
 Elect. Tech. RED Tech. APG

5.8.6 After High and Low Temperature, Liquid

Leakage, After High and Low Temperature, Liquid

100% helium @ 50 ± 5 ppg Internal Press	Allowable 1.6x10 <sup>-6</sup> sccs	Actual 5.5x10 <sup>-6</sup>	O. K. ✓	Reject	Initial HPJ
--	--	--------------------------------	------------	--------	----------------

Date \_\_\_\_\_

Comments: STANDARD LEAK RATE = 1.3x10<sup>-8</sup>  
STANDARD LEAK READING = 2.6 VALVE LEAK READING =  
TOTAL CYCLES = 2231

Port A Methanol/Water	Allowable	Actual			O. K.	Reject	Initial
		1	2	3			
5.0 ± .5 psig ΔP	0.20 sccs	0	0	0	✓		HPJ
10.0 ± 1.0 psig ΔP	0.20 sccs	0	0	0	✓		HPJ
20.0 ± 2.0 psig ΔP	0.20 sccs	0	0	0	✓		HPJ

Date \_\_\_\_\_

10-29-70

Port B Methanol/Water	Allowable	Actual			O. K.	Reject	Initial
		1	2	3			
5.0 ± .5 psig ΔP	0.20 sccs	0	0	0	✓		HPJ
10.0 ± 1.0 psig ΔP	0.20 sccs	0	0	0	✓		HPJ
20.0 ± 2.0 psig ΔP	0.20 sccs	0	0	0	✓		HPJ

Date \_\_\_\_\_

10-29-70

Comments: TOTAL CYCLES = 2250

Test Data Sheet  
Pulse Operated Flow Diverter Valve  
Specification 20M42517

Serial No. 007 Test Eng. RMR  
Mech. Tech. — Q. C. Eng. HPS  
Elect. Tech. RSD Tech. TECH

Circuit Resistance After High and Low Temperature, Liquid

Port "A" Open Pins		Limit	Actual		
From	To		1	2	3
A	E	0.5 ohms max.	0.1	0.1	0.1
D	F	0.5 ohms max.	0.1	0.1	0.1
H	Case	0.5 ohms max.	0.1	0	0
L	J	25-29 ohms	27.9	27.9	27.8
B	E	Open Circuit	OPEN	OPEN	OPEN
C	F	Open Circuit	OPEN	OPEN	OPEN

Accept ✓ Initial HPS  
Reject — Date 10-29-70

Port "B" Open Pins		Limit	Actual		
From	To		1	2	3
A	E	Open Circuit	OPEN	OPEN	OPEN
D	F	Open Circuit	OPEN	OPEN	OPEN
H	Case	0.5 ohms max.	0	0	0
M	K	25-29 ohms	27.9	27.2	27.2
B	E	0.5 ohms max.	0.1	0.1	0.1
C	F	0.5 ohms max.	0.1	0.1	0.1

Accept ✓ Initial HPS  
Reject — Date 10-29-70

Comments: TOTAL CYCLES = 2515

Test Data Sheet  
Pulse Operated Flow Diverter Valve  
Specification 20M42517

Serial No. 008 Test Eng. RMR  
Mech. Tech. — Q. C. Eng. HPC  
Elect. Tech. REC TECH —

Circuit Resistance After High and Low Temperature, Liquid

Port "A" Open Pins		Limit	Actual		
From	To		1	2	3
A	E	0.5 ohms max.	0.1	0.1	0.0
D	F	0.5 ohms max.	0.0	0.1	0.0
H	Case	0.5 ohms max.	0.0	0.0	0.0
L	J	25-29 ohms	25.3	25.4	25.1
B	E	Open Circuit	OPEN	OPEN	OPEN
C	F	Open Circuit	OPEN	OPEN	OPEN

Accept    
Reject

Initial HPC  
Date 10-29-70

Port "B" Open Pins		Limit	Actual		
From	To		1	2	3
A	E	Open Circuit	OPEN	OPEN	OPEN
D	F	Open Circuit	OPEN	OPEN	OPEN
H	Case	0.5 ohms max.	0	0	0
M	K	25-29 ohms	25.4	25.4	25.4
B	E	0.5 ohms max.	0	0	0.1
C	F	0.5 ohms max.	0.1	0.0	0.1

Accept    
Reject

Initial HPC  
Date 10-29-70

Comments: TOTAL CYCLES = 2258

Test Data Sheet  
Pulse Operated Flow Diverter Valve  
Specification 20M42517

Serial No. 007 Test Eng. RMR  
Mech. Tech.      Q. C. Eng. HFG  
Elect. Tech. REO TECH

500 Volts D. C.		Limit	Actual
Pins			
From	To		
A	C	50 meg. ohms min.	> 50 Mr ↓
A	D	50 meg. ohms min.	
A	F	50 meg. ohms min.	
A	H	50 meg. ohms min.	
A	J	50 meg. ohms min.	
A	L	50 meg. ohms min.	
A	M	50 meg. ohms min.	
A	Case	50 meg. ohms min.	
B	C	50 meg. ohms min.	
B	D	50 meg. ohms min.	
B	F	50 meg. ohms min.	
B	A	50 meg. ohms min.	
B	J	50 meg. ohms min.	





Test Data Sheet  
Pulse Operated Flow Diverter Valve  
Specification 20M42517

Serial No. 007 Test Eng. RMC  
Mech. Tech. ✓ Q. C. Eng. HCG  
Elect. Tech. RSC TCA

Continued

From	To	Limit	Actual
B	K	50 meg. ohms min.	> 50 meg.
B	L	50 meg. ohms min.	
B	M	50 meg. ohms min.	
B	Case	50 meg. ohms min.	
C	E	50 meg. ohms min.	
C	H	50 meg. ohms min.	
C	J	50 meg. ohms min.	
C	K	50 meg. ohms min.	
C	L	50 meg. ohms min.	
C	M	50 meg. ohms min.	
C	Case	50 meg. ohms min.	
D	E	50 meg. ohms min.	
D	H	50 meg. ohms min.	
D	J	50 meg. ohms min.	
D	K	50 meg. ohms min.	
D	L	50 meg. ohms min.	
D	M	50 meg. ohms min.	
D	Case	50 meg. ohms min.	
E	F	50 meg. ohms min.	
E	H	50 meg. ohms min.	
E	J	50 meg. ohms min.	
E	K	50 meg. ohms min.	
E	L	50 meg. ohms min.	
E	M	50 meg. ohms min.	
E	Case	50 meg. ohms min.	
F	H	50 meg. ohms min.	
F	J	50 meg. ohms min.	
F	K	50 meg. ohms min.	
F	L	50 meg. ohms min.	
F	M	50 meg. ohms min.	
F	Case	50 meg. ohms min.	
G	A	50 meg. ohms min.	
G	B	50 meg. ohms min.	
G	C	50 meg. ohms min.	
G	D	50 meg. ohms min.	
G	E	50 meg. ohms min.	



Test Data Sheet  
Pulse Operated Flow Diverter Valve  
Specification 20M42517

Serial No. 008 Test Eng. RMR  
Mech. Tech. - Q. C. Eng. HPG  
Elect. Tech. RSC TECH

Continued

From	To	Limit	Actual
B	K	50 meg. ohms min.	> 50 MΩ
B	L	50 meg. ohms min.	
B	M	50 meg. ohms min.	
B	Case	50 meg. ohms min.	
C	E	50 meg. ohms min.	
C	H	50 meg. ohms min.	
C	J	50 meg. ohms min.	
C	K	50 meg. ohms min.	
C	L	50 meg. ohms min.	
C	M	50 meg. ohms min.	
C	Case	50 meg. ohms min.	
D	E	50 meg. ohms min.	
D	H	50 meg. ohms min.	
D	J	50 meg. ohms min.	
D	K	50 meg. ohms min.	
D	L	50 meg. ohms min.	
D	M	50 meg. ohms min.	
D	Case	50 meg. ohms min.	
E	F	50 meg. ohms min.	
E	H	50 meg. ohms min.	
E	J	50 meg. ohms min.	
E	K	50 meg. ohms min.	
E	L	50 meg. ohms min.	
E	M	50 meg. ohms min.	
E	Case	50 meg. ohms min.	
F	H	50 meg. ohms min.	
F	J	50 meg. ohms min.	
F	K	50 meg. ohms min.	
F	L	50 meg. ohms min.	
F	M	50 meg. ohms min.	
F	Case	50 meg. ohms min.	
G	A	50 meg. ohms min.	
G	B	50 meg. ohms min.	
G	C	50 meg. ohms min.	
G	D	50 meg. ohms min.	
G	E	50 meg. ohms min.	

Test Data Sheet  
Pulse Operated Flow Diverter Valve  
Specification 20M42517

Serial No. 007  
Mech. Tech. —  
Elect. Tech. REO

Test Eng. RWR  
Q. C. Eng. HPG  
TEST

Continued

From	To	Limit	Actual
G	F	50 meg. ohms min.	$> 50 \text{ M}\Omega$ 
G	H	50 meg. ohms min.	
G	J	50 meg. ohms min.	
G	K	50 meg. ohms min.	
G	L	50 meg. ohms min.	
G	M	50 meg. ohms min.	
H	J	50 meg. ohms min.	
H	K	50 meg. ohms min.	
H	L	50 meg. ohms min.	
H	M	50 meg. ohms min.	
J	K	50 meg. ohms min.	
J	M	50 meg. ohms min.	
J	Case	50 meg. ohms min.	
K	L	50 meg. ohms min.	
K	Case	50 meg. ohms min.	
L	M	50 meg. ohms min.	
L	Case	50 meg. ohms min.	
M	Case	50 meg. ohms min.	

Accept   
Reject

Initial HPG  
Date 10-29-70

Comments: \_\_\_\_\_

Port "A" Open 500 Volts D. C. Pins		Limit	Actual
From	To		
B	E	50 meg. ohms min.	$> 50 \text{ M}\Omega$ 
B	A	50 meg. ohms min.	
C	D	50 meg. ohms min.	
C	F	50 meg. ohms min.	

Accept   
Reject

Initial HPG  
Date 10-29-70

Test Data Sheet  
Pulse Operated Flow Diverter Valve  
Specification 20M42517

Serial No. 008 Test Eng. RMW  
Mech. Tech. — Q. C. Eng. HFG  
Elect. Tech. REE JECW

Continued

From	To	Limit	Actual
G	F	50 meg. ohms min.	<u>&gt; 50 MΩ</u> 
G	H	50 meg. ohms min.	
G	J	50 meg. ohms min.	
G	K	50 meg. ohms min.	
G	L	50 meg. ohms min.	
G	M	50 meg. ohms min.	
H	J	50 meg. ohms min.	
H	K	50 meg. ohms min.	
H	L	50 meg. ohms min.	
H	M	50 meg. ohms min.	
J	K	50 meg. ohms min.	
J	M	50 meg. ohms min.	
J	Case	50 meg. ohms min.	
K	L	50 meg. ohms min.	
K	Case	50 meg. ohms min.	
L	M	50 meg. ohms min.	
L	Case	50 meg. ohms min.	
M	Case	50 meg. ohms min.	

Accept  Initial HFG  
Reject  Date 10-29-70

Comments: \_\_\_\_\_

Port "A" Open 500 Volts D. C. Pins		Limit	Actual
From	To		
B	E	50 meg. ohms min.	<u>&gt; 50 MΩ</u> 
B	A	50 meg. ohms min.	
C	D	50 meg. ohms min.	
C	F	50 meg. ohms min.	

Accept  Initial HFG  
Reject  Date 10-29-70

Test Data Sheet  
 Pulse Operated Flow Diverter Valve  
 Specification 20M42517

Serial No. 007 Test Eng. RNTR  
 Mech. Tech. — Q. C. Eng. HPS  
 Elect. Tech. RCO TECH

Port "B" Open 500 Volts D. C. Pins		Limit	Actual
From	To		
A	B	50 meg. ohms min.	750 MΩ ↓
A	E	50 meg. ohms min.	
D	C	50 meg. ohms min.	
D	F	50 meg. ohms min.	

Accept  Initial HPS  
 Reject  Date 10-27-70

Comments: TOTAL CYCLES = 2517

Position Indicators After High and Low Temperature Liquid

Covered by Circuit Resistance Test.

Minimum Voltage, After High and Low Temperature, Liquid

Minimum Operating Voltage 100ms Pulse, Unpressurized	Allowable	Actual			O. K.	Reject	Initial
		1	2	3			
Port "A"	18 volts d. c. max.	17.0	16.0	16.0	✓		HPS
Port "B"	18 volts d. c. max.	16.0	16.0	19.0	✓		HPS

Comments: TOTAL CYCLES = 2529 Date 11/2/70

Minimum Operating Voltage 100ms Pulse 50 ± 5 psig, 100% Helium	Allowable	Actual			O. K.	Reject	Initial
		1	2	3			
Port "A"	18 volts d. c. max.	16.0	16.0	16.0	✓		HPS
Port "B"	18 volts d. c. max.	17.0	17.0	16.0	✓		HPS

Comments: TOTAL CYCLES = 2538 Date 11/2/70

**Pulse Operated Flow Diverter Valve  
Specification 20M42517**

Serial No. 008 Test Eng. RMR  
 Mech. Tech. — Q. C. Eng. HPG  
 Elect. Tech. RED TELL

Port "B" Open 500 Volts D. C. Pins		Limit	Actual
From	To		
A	B	50 meg. ohms min.	750 MΩ ↓
A	E	50 meg. ohms min.	
D	C	50 meg. ohms min.	
D	F	50 meg. ohms min.	

Accept  Initial HPG  
 Reject  Date 10-29-70

Comments: \_\_\_\_\_

Position Indicators After High and Low Temperature Liquid

Covered by Circuit Resistance Test.

Minimum Voltage, After High and Low Temperature, Liquid

Minimum Operating Voltage 100ms Pulse, Unpressurized	Allowable	Actual			O. K.	Reject	Ini
		1	2	3			
Port "A"	18 volts d. c. max.	17.0	16.0	16.0	✓		HP
Port "B"	18 volts d. c. max.	16.0	16.5	17.0	✓		HP

Date 11/2/70

Comments: TOTAL CYCLES = 2268

Minimum Operating Voltage 100ms Pulse 50 ± 5 psig, 100% Helium	Allowable	Actual			O. K.	Reject	Ini
		1	2	3			
Port "A"	18 volts d. c. max.	16.0	16.0	16.0	✓		HP
Port "B"	18 volts d. c. max.	16.5	16.0	16.0	✓		HP

Date 11/2/70

Comments: TOTAL CYCLES = 2278



Test Data Sheet

Pulse Operated Flow Diverter Valve  
Specification 20M42517

Serial No. 608 Test Eng. R.M.R.  
 Mech. Tech. REO Q. C. Eng. H.P.G.  
 Elect. Tech. REO TEC

Pulse Duration, After High and Low Temperature, Liquid

Minimum Pulse Duration, 28 Volts D. C. 100% Helium, 50 ± 5 psig	Allowable	Actual			O.K.	Reject	Initial
		1	2	3			
Port "A"	100 ms. max.	33.0	32.0	32.0	✓		H.P.G.
Port "B"		34.0	33.0	34.0	✓		H.P.G.

Photo Taken 11/2/70   
 Date

Comments: TOTAL CYCLES = 2278

Minimum Pulse Duration, 28 Volts D. C. Zero Press	Allowable	Actual			O.K.	Reject	Initial
		1	2	3			
Port "A"	100 ms. max.	33.0	34.0	33.0	✓		H.P.G.
Port "B"		34.0	34.0	34.0	✓		H.P.G.

Photo Taken 11/2/70   
 Date

Comments: TOTAL CYCLES = 2288

Power, After High and Low Temperature, Liquid

Power 28 Volts D. C. Steady State	Allowable	A B		O.K.	Reject	Initial
		Actual				
Voltage	28 ± .5	28.0	28.0	✓		H.P.G.
Current	1.14 amps	1.07	1.07	✓		H.P.G.
Power	31.5 watts max.	27.9	27.9	✓		H.P.G.

Date 10-29-70 

Comments: TOTAL CYCLES = 2289



Pulse Operated Flow Diverter Valve  
Specification 20M42517

Serial No. 007  
Mech. Tech. ✓  
Elect. Tech. REC

Test Eng. RMR  
Q. C. Eng. ALT/CRW  
TECH

5.9 Full Flow

P @ 900 lb/hr Room Temp.	Allowable	Actual			O. K.	Reject	Initial
		1	2	3			
Port A - C	0.5 psid max.	0.23	0.31	0.36	✓		ALRT
Port B - C	0.5 psid max.	0.22	0.32	0.32	✓		ALRT
Port C - A	0.5 psid max.	0.32	0.38	0.38	✓		ALRT
Port C - B	0.5 psid max.	0.42	0.45	0.40	✓		ALRT

Photo Taken ✓

Date 5 November '70

Comments: FLOW METER S-3586 DUR NOVEMBER '71  
TOTAL CYCLES = 2564.

Circuit Resistance During Full Flow

Port "A" Open Pins		Limit	Actual		
From	To		1	2	3
A	E	0.5 ohms max.	0.4	0.5	0.5
D	F	0.5 ohms max.	0.4	0.5	0.4
H	Case	0.5 ohms max.	0.5	0.5	0.4
L	J	25-29 ohms	27.6	27.9	28.2
B	E	Open Circuit	INF.	INF.	INF.
C	F	Open Circuit	INF.	INF.	INF.

Accept ✓

Reject \_\_\_\_\_

Initial CRW

Date 11/9/70

Port "B" Open Pins		Limit	Actual		
From	To		1	2	3
A	E	Open Circuit	INF	INF	INF
D	F	Open Circuit	INF	INF	INF
H	Case	0.5 ohms max.	0.1	0.1	0.2
M	K	25-29 ohms	28.6	28.1	28.9
B	E	0.5 ohms max.	0.3	0.2	0.3
C	F	0.5 ohms max.	0.3	0.2	0.3

Accept ✓

Reject \_\_\_\_\_

Initial CRW

Date 11/9/70

Comments: \_\_\_\_\_

Pulse Operated Flow Diverter Valve  
Specification 20M42517

Serial No. 008 Test Eng. RMR  
 Mech. Tech. REO Q. C. Eng. CBW  
 Elect. Tech. REO TECH

5.9 Full Flow

P @ 900 lb/hr Room Temp.	Allowable	Actual			O. K.	Reject	Initial
		1	2	3			
Port A - C	0.5 psid max.	.49	.38	.4	✓		CBW
Port B - C	0.5 psid max.	.25	.27	.34	✓		CBW
Port C - A	0.5 psid max.	.38	.38	.38	✓		CBW
Port C - B	0.5 psid max.	.22	.33	.35	✓		CBW

Photo Taken ✓  
 Date 11/5/70

Comments: TOTAL CYCLES = 2205

Circuit Resistance During Full Flow

Port "A" Open Pins		Limit	Actual		
From	To		1	2	3
A	E	0.5 ohms max.	0.5	0.3	0.3
D	F	0.5 ohms max.	0.5	0.3	0.3
H	Case	0.5 ohms max.	0.1	0.3	0.4
L	J	25-29 ohms	27.1	27.5	26.9
B	E	Open Circuit	INF	INF	INF
C	F	Open Circuit	INF	INF	INF

Accept ✓ Initial CBW  
 Reject \_\_\_\_\_ Date 11/9/70

Port "B" Open Pins		Limit	Actual		
From	To		1	2	3
A	E	Open Circuit	INF	INF	INF
D	F	Open Circuit	INF	INF	INF
H	Case	0.5 ohms max.	0.1	0.3	0.3
M	K	25-29 ohms	27.3	27.2	27.4
B	E	0.5 ohms max.	0.3	0.4	0.4
C	F	0.5 ohms max.	0.3	0.3	0.3

Accept ✓ Initial CBW  
 Reject \_\_\_\_\_ Date 11/9/70

Comments: TOTAL CYCLES = 2312



Test Data Sheet

Pulse Operated Flow Diverter Valve  
Specification 20M42517

Serial No. 008 Test Eng. RMR  
Mech. Tech. \_\_\_\_\_ Q. C. Eng. \_\_\_\_\_  
Elect. Tech. RED

Minimum Voltage During Full Flow

Minimum Operating Voltage 100 ms Pulse, Unpressurized	Allowable	Actual			O. K.	Reject	In
		1	2	3			
Port "A"	18 volts d. c. max.	16	15	15	L		CB
Port "B"	18 volts d. c. max.	16	16	15	✓		CB

Date 11/9/70

Comments: TOTAL CYCLES = 2334

Test Data Sheet  
Pulse Operated Flow Diverter Valve  
Specification 20M42517

Serial No. 007 Test Eng. RMV  
Mech. Tech. — Q. C. Eng. CBW  
Elect. Tech. REO TECH

Minimum Pulse Duration, 28 Volts D. C. Zero Press	Allowable	Actual			O. K.	Reject	Initial
		1	2	3			
Port "A"	100 ms. max.	32	30	32	✓		CBW
Port "B"		35	36	35	✓		CBW

Date 11/9/70

Comments: TOTAL CYCLES = 2616

Power During Full Flow

Power 28 Volts D. C. Steady State	Allowable	A B		O. K.	Reject	Initial
		Actual	Actual			
Voltage	28 ± .5	28.0	28.0	✓		CBW
Current	1.14 amps	1.97	1.94	✓		CBW
Power	31.5 watts max.	27.2	26.3	✓		

Date 11/9/70

Comments: —

Test Data Sheet  
Pulse Operated Flow Diverter Valve  
Specification 20M42517

Serial No. 008 Test Eng. RMR  
Mech. Tech.      Q. C. Eng. CBW  
Elect. Tech. RCO Tech.     

Minimum Pulse Duration, 28 Volts D. C. Zero Press	Allowable	Actual			O.K.	Reject	Initial
		1	2	3			
Port "A"	100 ms. max.	33	35	30	✓		CBW
Port "B"		32	34	33	✓		CBW

Date 11/9/70  
Comments: TOTAL CYCLES = 2352

Power During Full Flow

Power 28 Volts D. C. Steady State	Allowable	A B		O.K.	Reject	Initial
		Actual	Actual			
Voltage	28 ± .5	27.8	27.8	✓		CBW
Current	1.14 amps	1.04	1.00	✓		CBW
Power	31.5 watts max.	28.9	27.8	✓		CBW

Date 11/9/70  
Comments: TOTAL CYCLES = 2354

5.10 Humidity

Per 5.10 240 Hrs.	Allowable	O.K.	Reject	Initial
Examination	No failure or damage	✓		WRC

Photo Taken OK  
Date 23 Nov 70

Comments: WITNESSED SET UP 11-13-70 J. Boran AFQAR  
9-30 AM  
11-23-70 12:45 PM J. Boran AFQAR

Test Data Sheet

Pulse Operated Flow Diverter Valve  
Specification 20M42517

Serial No. 008  
 Mech. Tech. \_\_\_\_\_  
 Elect. Tech. REO

Test Eng. RMR  
 Q. C. Eng. 11-23-70

Leakage After Humidity

100% helium @ 50 ± 5 ppg	Allowable	Actual	O. K.	Reject
Internal Press	1.6 x 10 <sup>-6</sup> sccs	.47x10 <sup>-6</sup>	✓	

Date 11-23-70

Comments: TOTAL CYCLES = 2360

Port A Methanol/Water	Allowable	Actual			O. K.	Reject	Initial
		1	2	3			
5.0 ± .5 psig ΔP	0.20 sccs	0.0	0.0	0.0	✓		<i>AM</i>
10.0 ± 1.0 psig ΔP	0.20 sccs	0.0	0.0	0.0	✓		<i>AM</i>
20.0 ± 2.0 psig ΔP	0.20 sccs	0.0	0.0	0.0	✓		<i>AM</i>

Date 11-23-70

Port B Methanol/Water	Allowable	Actual			O. K.	Reject	Initial
		1	2	3			
5.0 ± .5 psig ΔP	0.20 sccs	0.0	0.0	0.0	✓		<i>AM</i>
10.0 ± 1.0 psig ΔP	0.20 sccs	0.0	0.0	0.0	✓		<i>AM</i>
20.0 ± 2.0 psig ΔP	0.20 sccs	0.0	0.0	0.0	✓		<i>AM</i>

Date 11-23-70

Comments: TOTAL CYCLES = 2366



Pulse Operated Flow Diverter Valve  
Specification 20M42517

Serial No. 008 Test Eng. RMR  
 Mech. Tech. \_\_\_\_\_ Q. C. Eng. ALT  
 Elect. Tech. REO Tech. \_\_\_\_\_

Circuit Resistance After Humidity

Port "A" Open Pins		Limit	Actual		
From	To		1	2	3
A	E	0.5 ohms max.	0.2	0.15	0.4
D	F	0.5 ohms max.	0.3	0.4	0.4
H	Case	0.5 ohms max.	0.3	0.3	0.3
L	J	25-29 ohms	25.6	25.7	25.7
B	E	Open Circuit	OPEN	open	OPEN
C	F	Open Circuit	OPEN	open	OPEN

Accept  Initial ALT  
 Reject \_\_\_\_\_ Date 11-23-70

Port "B" Open Pins		Limit	Actual		
From	To		1	2	3
A	E	Open Circuit	OPEN	OPEN	OPEN
D	F	Open Circuit	OPEN	OPEN	OPEN
H	Case	0.5 ohms max.	0.15	0.0	0.0
M	K	25-29 ohms	25.7	25.5	25.4
B	E	0.5 ohms max.	0.4	0.1	0.1
C	F	0.5 ohms max.	0.3	0.1	0.1

Accept  Initial ALT  
 Reject \_\_\_\_\_ Date 11-23-70

Comments: TOTAL CYCLES = 2372



Test Data Sheet  
Pulse Operated Flow Diverter Valve  
Specification 20M42517

HPC-A  
U-2370

Serial No. 008  
Mech. Tech. \_\_\_\_\_  
Elect. Tech. REC

Test Eng. RMR  
Q. C. Eng. AM 11-23-70

Insulation Resistance After Humidity

500 Volts D. C.		Limit	Actual
Pins			
From	To		
A	C	50 meg. ohms min.	<p>&gt; 50 meg. Ω</p> <p>&gt; 50 meg. Ω</p>
A	D	50 meg. ohms min.	
A	F	50 meg. ohms min.	
A	H	50 meg. ohms min.	
A	J	50 meg. ohms min.	
A	L	50 meg. ohms min.	
A	M	50 meg. ohms min.	
A	Case	50 meg. ohms min.	
B	C	50 meg. ohms min.	
B	D	50 meg. ohms min.	
B	F	50 meg. ohms min.	
B	A	50 meg. ohms min.	
B	J	50 meg. ohms min.	

Test Data Sheet  
Pulse Operated Flow Diverter Valve  
Specification 20M42517

Serial No. 008  
Mech. Tech. \_\_\_\_\_  
Elect. Tech. REC

Test Eng. RMR  
Q. C. Eng. Alt 11-23-70

11-23-70

Continued

From	To	Limit	Actual
B	K	50 meg. ohms min.	
B	L	50 meg. ohms min.	
B	M	50 meg. ohms min.	
B	Case	50 meg. ohms min.	
C	E	50 meg. ohms min.	
C	H	50 meg. ohms min.	
C	J	50 meg. ohms min.	
C	K	50 meg. ohms min.	
C	L	50 meg. ohms min.	
C	M	50 meg. ohms min.	
C	Case	50 meg. ohms min.	
D	E	50 meg. ohms min.	
D	H	50 meg. ohms min.	
D	J	50 meg. ohms min.	
D	K	50 meg. ohms min.	
D	L	50 meg. ohms min.	
D	M	50 meg. ohms min.	
D	Case	50 meg. ohms min.	
E	F	50 meg. ohms min.	
E	H	50 meg. ohms min.	
E	J	50 meg. ohms min.	
E	K	50 meg. ohms min.	
E	L	50 meg. ohms min.	
E	M	50 meg. ohms min.	
E	Case	50 meg. ohms min.	
F	H	50 meg. ohms min.	
F	J	50 meg. ohms min.	
F	K	50 meg. ohms min.	
F	L	50 meg. ohms min.	
F	M	50 meg. ohms min.	
F	Case	50 meg. ohms min.	
G	A	50 meg. ohms min.	
G	B	50 meg. ohms min.	
G	C	50 meg. ohms min.	
G	D	50 meg. ohms min.	
G	E	50 meg. ohms min.	> 50 mega

Test Data Sheet  
Pulse Operated Flow Diverter Valve  
Specification 20M42517

Serial No. 008 Test Eng. EMR  
Mech. Tech. — Q. C. Eng. ALT  
Elect. Tech. REC JAW

Continued

From	To	Limit	Actual
G	F	50 meg. ohms min.	$> 50 \text{ meg}\Omega$ ↑ ↓ $> 50 \text{ meg}\Omega$
G	H	50 meg. ohms min.	
G	J	50 meg. ohms min.	
G	K	50 meg. ohms min.	
G	L	50 meg. ohms min.	
G	M	50 meg. ohms min.	
H	J	50 meg. ohms min.	
H	K	50 meg. ohms min.	
H	L	50 meg. ohms min.	
H	M	50 meg. ohms min.	
J	K	50 meg. ohms min.	
J	M	50 meg. ohms min.	
J	Case	50 meg. ohms min.	
K	L	50 meg. ohms min.	
K	Case	50 meg. ohms min.	
L	M	50 meg. ohms min.	
L	Case	50 meg. ohms min.	
M	Case	50 meg. ohms min.	

Accept  Initial ALT  
Reject  Date 11-23-70

Comments: \_\_\_\_\_

Port "A" Open 500 Volts D. C. Pins		Limit	Actual
From	To		
B	E	50 meg. ohms min.	$> 50 \text{ meg}\Omega$ ↑ ↓ $> 50 \text{ meg}\Omega$
B	A	50 meg. ohms min.	
C	D	50 meg. ohms min.	
C	F	50 meg. ohms min.	

Accept  Initial ALT  
Reject  Date 11-23-70



Test Data Sheet  
Pulse Operated Flow Diverter Valve  
Specification 20M42517

Serial No. 008  
Mech. Tech. \_\_\_\_\_  
Elect. Tech. PEO

Test Eng. RMR  
Q. C. Eng. HPS  
TECH

Pulse Duration After Humidity

Minimum Pulse Duration, 28 Volts D. C. 100% Helium, 50 ± 5 psig	Allowable	Actual			O.K.	Reject	Initial
		1	2	3			
Port "A"	100 ms. max.	30	29	27	✓		HPS
Port "B"		30	32	31	✓		HPS

Date 11/24/70  
Comments: TOTAL CYCLES = 2422

Minimum Pulse Duration, 28 Volts D. C. Zero Press	Allowable	Actual			O.K.	Reject	Initial
		1	2	3			
Port "A"	100 ms. max.	29	28	32	✓		HPS
Port "B"		29	31	28	✓		HPS

Date 11/24/70  
Comments: TOTAL CYCLES = 2434

Power After Humidity

Power 28 Volts D. C. Steady State	Allowable	COIL COIL		O.K.	Reject	Initial
		A Actual	B Actual			
Voltage	28 ± .5	28.0	28.0	✓		HPS
Current	1.14 amps	1.07	1.05	✓		HPS
Power	31.5 watts max.	29.9	29.4	✓		HPS

Date 11/24/70  
Comments: TOTAL CYCLES = 2435

Test Data Sheet  
Pulse Operated Flow Diverter Valve  
Specification 20M42517

Serial No. 008  
Mech. Tech. \_\_\_\_\_  
Elect. Tech. REO

Test Eng. RMR  
Q. C. Eng. WRC/FFC  
TECH

5.11 Salt Fog

This test has been deleted by Modification 5 to the contract.

5.12 Sand and Dust

This test has been deleted by Modification 5 to the contract.

5.13 Fungus

This test has been deleted by Modification 5 to the contract.

5.14 Collapse Pressure

Ext. Pressure = 19 psig min. Int. Pressure = 0 psig for 3 Minutes Minimum Examine	Allowable	Actual			o.k.	Reject	Initial
		Int. Press.	Ext. Press.	Time			
	No rupture	0 PSIG	190 PSIG	3	✓		WRC

Photo Taken YES  
Date 12-4-70

Comments: VALVE CYCLED AFTER TEST. NO PROBLEM WITH OPERATION.  
TOTAL CYCLES = 2440

5.15 Burst Pressure

1. Hydrostatic Pressure 125 psig min, for 3 min. 2. Increase Pressure to Burst	Allowable	Actual		O.K.	Reject	Initial
		Pressure	Time			
1. Examination	No rupture	130 PSIG	3 MIN	✓		
2. Measure Rupture Pressure	Greater than 125 psig	* 450 PSIG	—	✓		<u>DATE</u>

Photo Taken \_\_\_\_\_  
Date 12/4/70

Comments: \* DIAPHRAGM BURST  
COVER BURST = 2000 PSIG. VALVE SUCCESSFULLY OPERATED  
AFTER 125 PSIG BURST TEST. TOTAL CYCLES = 2447

Test Data Sheet  
Pulse Operated Flow Diverter Valve  
Specification 20M42517

Serial No. 007  
Mech. Tech. —  
Elect. Tech. RED

Test Eng. RMR  
Q. C. Eng. HG  
TECH

5.16 Temperature Cycling

200 Thermal cycles, from 0°F to 120°F. Each cycle within 90 minutes.	Allowable	Actual		O.K.	Reject	In.
	No perman- ent damage or loss of function	Time	Cycle			
		~55 MINUTES	203	✓		HG

Comments: COMPLETED 12-1-70

12/12/70 all  
10:00 AM

Test Data Sheet  
Pulse Operated Flow Diverter Valve  
Specification 20M42517

Serial No. 007  
Mech. Tech.                       
Elect. Tech. REO

Test Eng. RMR  
Q. C. Eng. WRC  
TEA

Leakage After Thermal Cycling

100% helium @ 50 ± 5 ppg	Allowable	Actual	O. K.	Reject	Initial
Internal Press	1: 6x10 <sup>-6</sup> sccs	.72x10 <sup>-6</sup>	✓		WRC

Date \_\_\_\_\_

Comments: TOTAL CYCLES = 2616

Port A Methanol/Water	Allowable	Actual			O. K.	Reject	Initial
		1	2	3			
5.0 ± .5 psig ΔP	0.20 sccs	0	0	0	✓		WRC
10.0 ± 1.0 psig ΔP	0.20 sccs	0	0	0	✓		WRC
20.0 ± 2.0 psig ΔP	0.20 sccs	0	0	0	✓		WRC

Date 2 DEC 70

Port B Methanol/Water	Allowable	Actual			O. K.	Reject	Initial
		1	2	3			
5.0 ± .5 psig ΔP	0.20 sccs	0	0	0	✓		WRC
10.0 ± 1.0 psig ΔP	0.20 sccs	0	0	0	✓		WRC
20.0 ± 2.0 psig ΔP	0.20 sccs	0	0	0	✓		WRC

Date 2 DEC 70

Comments: TOTAL CYCLES = 2626



Test Data Sheet  
Pulse Operated Flow Diverter Valve  
Specification 20M42517

Serial No. 007  
Mech. Tech. —  
Elect. Tech. RED

Test Eng. RMVZ  
Q. C. Eng. WRC  
TECH

Circuit Resistance After Thermal Cycling

Port "A" Open Pins		Limit	Actual		
From	To		1	2	3
A	E	0.5 ohms max.	.1	.2	.1
D	F	0.5 ohms max.	.1	.2	.2
H	Case	0.5 ohms max.	0	0	.1
L	J	25-29 ohms	27.9	27.9	27.9
B	E	Open Circuit	∞	∞	∞
C	F	Open Circuit	∞	∞	∞

Accept   
Reject



Initial WRC  
Date 2 DEC 70

Port "B" Open Pins		Limit	Actual		
From	To		1	2	3
A	E	Open Circuit	∞	∞	∞
D	F	Open Circuit	∞	∞	∞
H	Case	0.5 ohms max.	.2	.3	.4
M	K	25-29 ohms	28	28.1	28.2
B	E	0.5 ohms max.	.3	.3	.3
C	F	0.5 ohms max.	.4	.3	.5

Accept   
Reject



Initial WRC  
Date 2 DEC 70

Comments: \_\_\_\_\_

TOTAL CYCLES = 2632

Test Data Sheet  
Pulse Operated Flow Diverter Valve  
Specification 20M42517

Serial No. 007  
Mech. Tech. ~  
Elect. Tech. REO

Test Eng. RMR  
Q. C. Eng. WRC  
TECH

Insulation Resistance After Thermal Cycling

500 Volts D. C. Pins		Limit	Actual
From	To		
A	C	50 meg. ohms min.	
A	D	50 meg. ohms min.	
A	F	50 meg. ohms min.	
A	H	50 meg. ohms min.	
A	J	50 meg. ohms min.	
A	L	50 meg. ohms min.	
A	M	50 meg. ohms min.	
A	Case	50 meg. ohms min.	
B	C	50 meg. ohms min.	
B	D	50 meg. ohms min.	
B	F	50 meg. ohms min.	
B	A	50 meg. ohms min.	
B	J	50 meg. ohms min.	

WRC  
2 DEC 70

Test Data Sheet  
Pulse Operated Flow Diverter Valve  
Specification 20M42517

Serial No. 007  
Mech. Tech. \_\_\_\_\_  
Elect. Tech. RED

Test Eng. RMR  
Q. C. Eng. WRE  
TELA

Continued

From	To	Limit	Actual
B	K	50 meg. ohms min.	> 50 MEG Ω
B	L	50 meg. ohms min.	↑ ↓
B	M	50 meg. ohms min.	
B	Case	50 meg. ohms min.	
C	E	50 meg. ohms min.	
C	H	50 meg. ohms min.	
C	J	50 meg. ohms min.	
C	K	50 meg. ohms min.	
C	L	50 meg. ohms min.	
C	M	50 meg. ohms min.	
C	Case	50 meg. ohms min.	
D	E	50 meg. ohms min.	
D	H	50 meg. ohms min.	
D	J	50 meg. ohms min.	
D	K	50 meg. ohms min.	
D	L	50 meg. ohms min.	
D	M	50 meg. ohms min.	
D	Case	50 meg. ohms min.	
E	F	50 meg. ohms min.	
E	H	50 meg. ohms min.	
E	J	50 meg. ohms min.	
E	K	50 meg. ohms min.	
E	L	50 meg. ohms min.	
E	M	50 meg. ohms min.	
E	Case	50 meg. ohms min.	
F	H	50 meg. ohms min.	
F	J	50 meg. ohms min.	
F	K	50 meg. ohms min.	
F	L	50 meg. ohms min.	
F	M	50 meg. ohms min.	
F	Case	50 meg. ohms min.	
G	A	50 meg. ohms min.	
G	B	50 meg. ohms min.	
G	C	50 meg. ohms min.	
G	D	50 meg. ohms min.	
G	E	50 meg. ohms min.	

  
2 DEC 70



Test Data Sheet  
 Pulse Operated Flow Diverter Valve  
 Specification 20M42517

Serial No. 007  
 Mech. Tech. \_\_\_\_\_  
 Elect. Tech. RED

Test Eng. RMR  
 Q. C. Eng. WRC  
TECH

Port "B" Open 500 Volts D. C. Pins		Limit	Actual
From	To		
A	B	50 meg. ohms min.	750 MEG Ω
A	E	50 meg. ohms min.	↑ 750 MEG Ω
D	C	50 meg. ohms min.	
D	F	50 meg. ohms min.	

Accept    Initial WRC  
 Reject \_\_\_\_\_ Date 2 DEC 70

Comments: \_\_\_\_\_

Position Indicators After Thermal Cycling

Covered by Circuit Resistance Test.

Minimum Voltage After Thermal Cycling

Minimum Operating Voltage 100 ms Pulse, Unpressurized	Allowable	Actual			O. K.	Reject	Initial
		1	2	3			
Port "A"	18 volts d. c. max.	17	17	17	✓		WRC
Port "B"	18 volts d. c. max.	17	16	16	✓		WRC

Date 3 DEC 70

Comments: TOTAL CYCLES = 2642

Minimum Operating Voltage 100 ms Pulse 50 ± 5 psig, 100% Helium	Allowable	Actual			O. K.	Reject	Initial
		1	2	3			
Port "A"	18 volts d. c. max.	17	16	16	✓		WRC
Port "B"	18 volts d. c. max.	15	16	15	✓		WRC

Date 3 DEC 70

Comments: TOTAL CYCLES = 2654

**Pulse Operated Flow Diverter Valve  
Specification 20M42517**

Serial No. 007 Test Eng. RMR  
 Mech. Tech.                      Q. C. Eng. WPC  
 Elect. Tech. RED TECH

Pulse Duration After Thermal Cycling

Minimum Pulse Duration, 28 Volts D. C. 100% Helium, 50 ± 5 psig	Allowable	Actual			O.K.	Reject	Initial
		1	2	3			
Port "A"	100 ms. max.	33	32	32	✓		WPC
Port "B"		30	30	30	✓		WPC

Date 3 DEC 70

Comments: TOTAL CYCLES = 2665

Minimum Pulse Duration, 28 Volts D. C. Zero Press	Allowable	Actual			O.K.	Reject	Initial
		1	2	3			
Port "A"	100 ms. max.	32	31	32	✓		WPC
Port "B"		30	30	30	✓		WPC

Date 3 DEC 70

Comments: TOTAL CYCLES = 2675

Power After Thermal Cycling

Power 28 Volts D. C. Steady State	Allowable	A	B	O.K.	Reject	Initial
		Actual				
Voltage	28 ± .5	28	28	✓		WPC
Current	1.14 amps	.98	.97	✓		WPC
Power	31.5 watts max.	27.4	27.1	✓		WPC

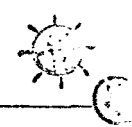
Date 2 DEC 70 

Comments: TOTAL CYCLES = 2676

**5.17. Compatibility**

This test has been deleted by Modification 5 to the contract.

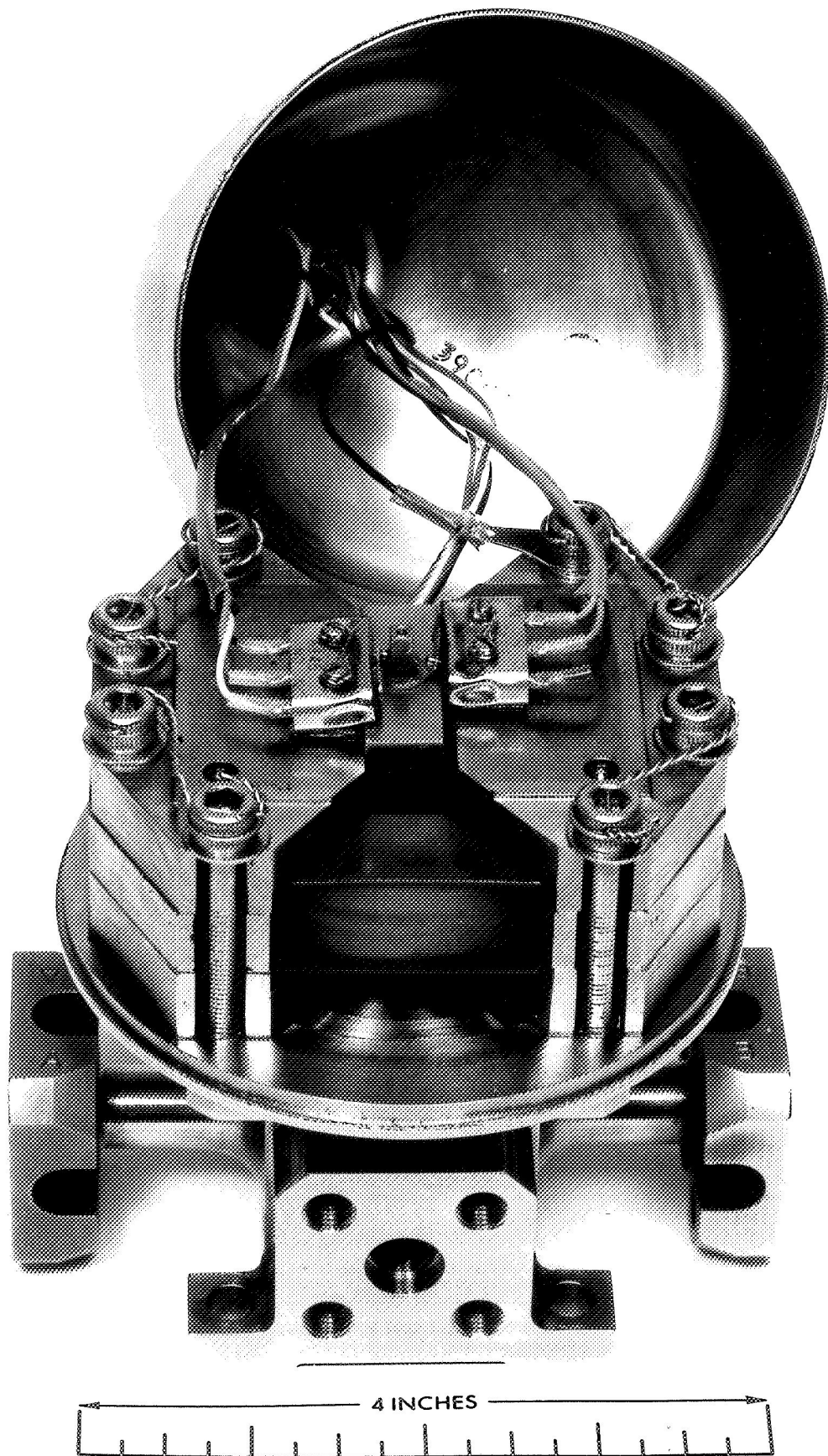

Exposed Torque Motor Assembly After Destructive Burst Test



Diaphragm Failure Point As A Result of Destructive Burst Test



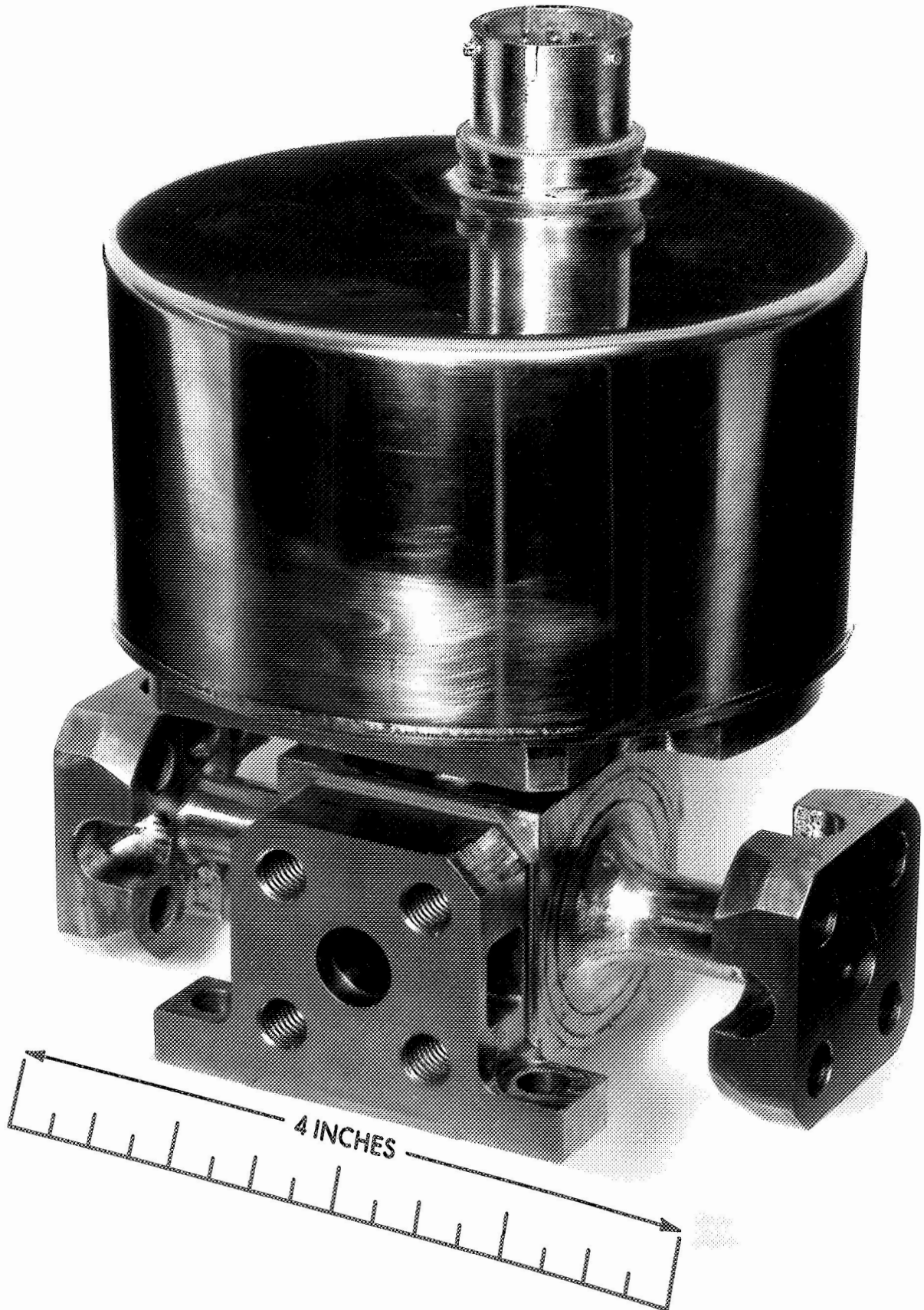

Flow Diverter Valve/Hydraulic Research P/N 39000750

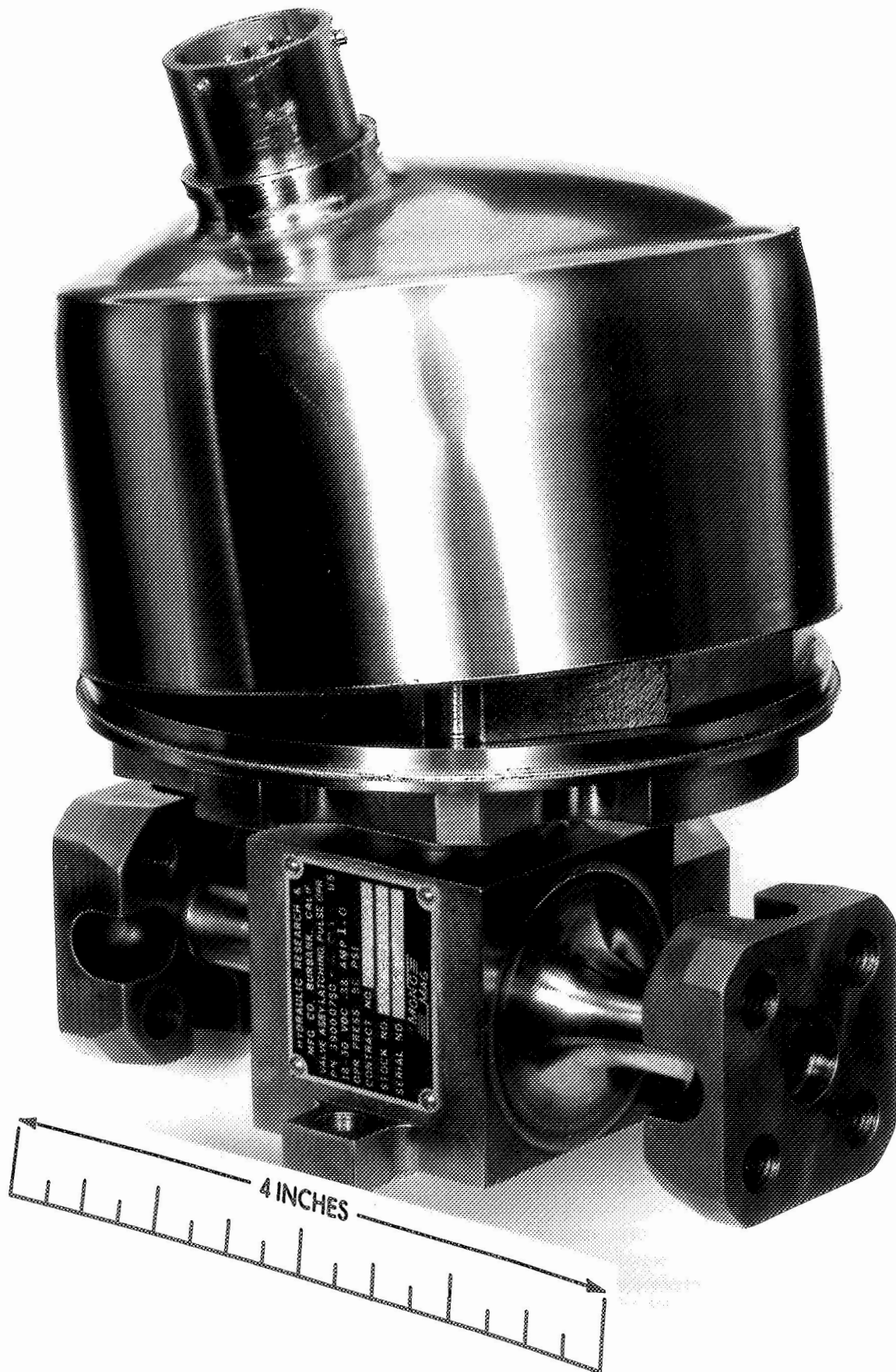

Flow Diverter Valve After Destructive Burst Test

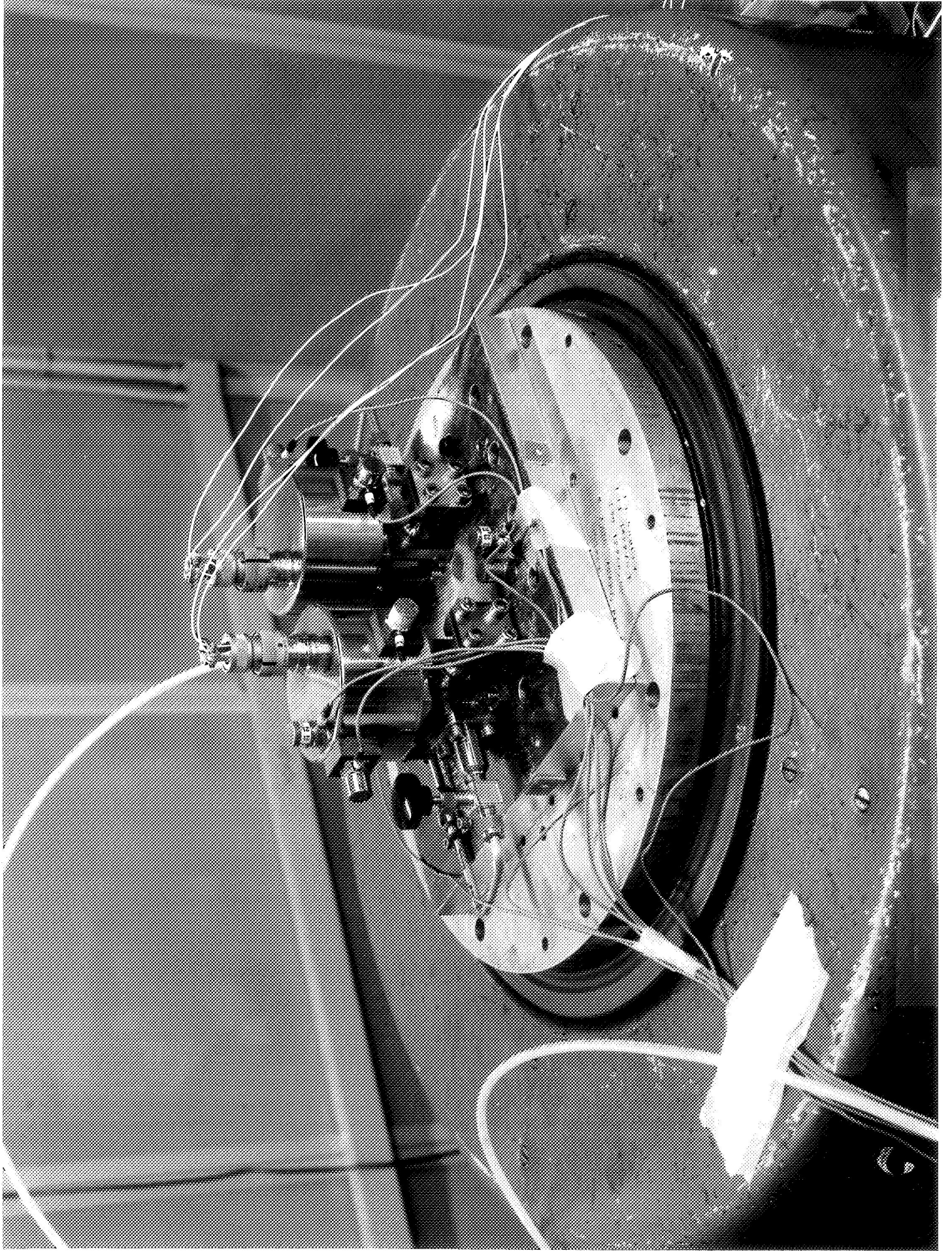

Sinusoidal Vibration Along Major (Z) Axis of Valve

Sinusoidal Vibration Along Port C Axis

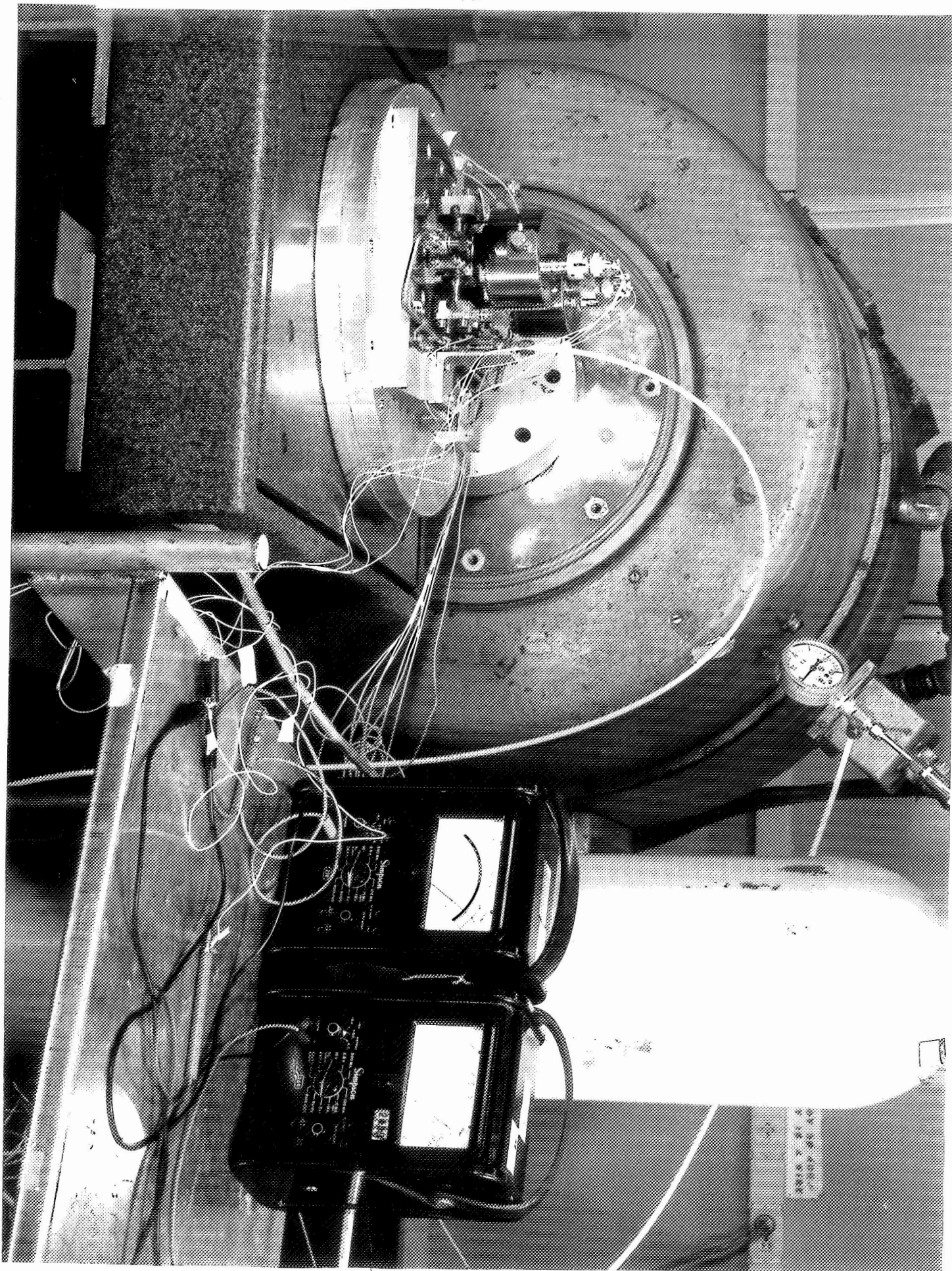

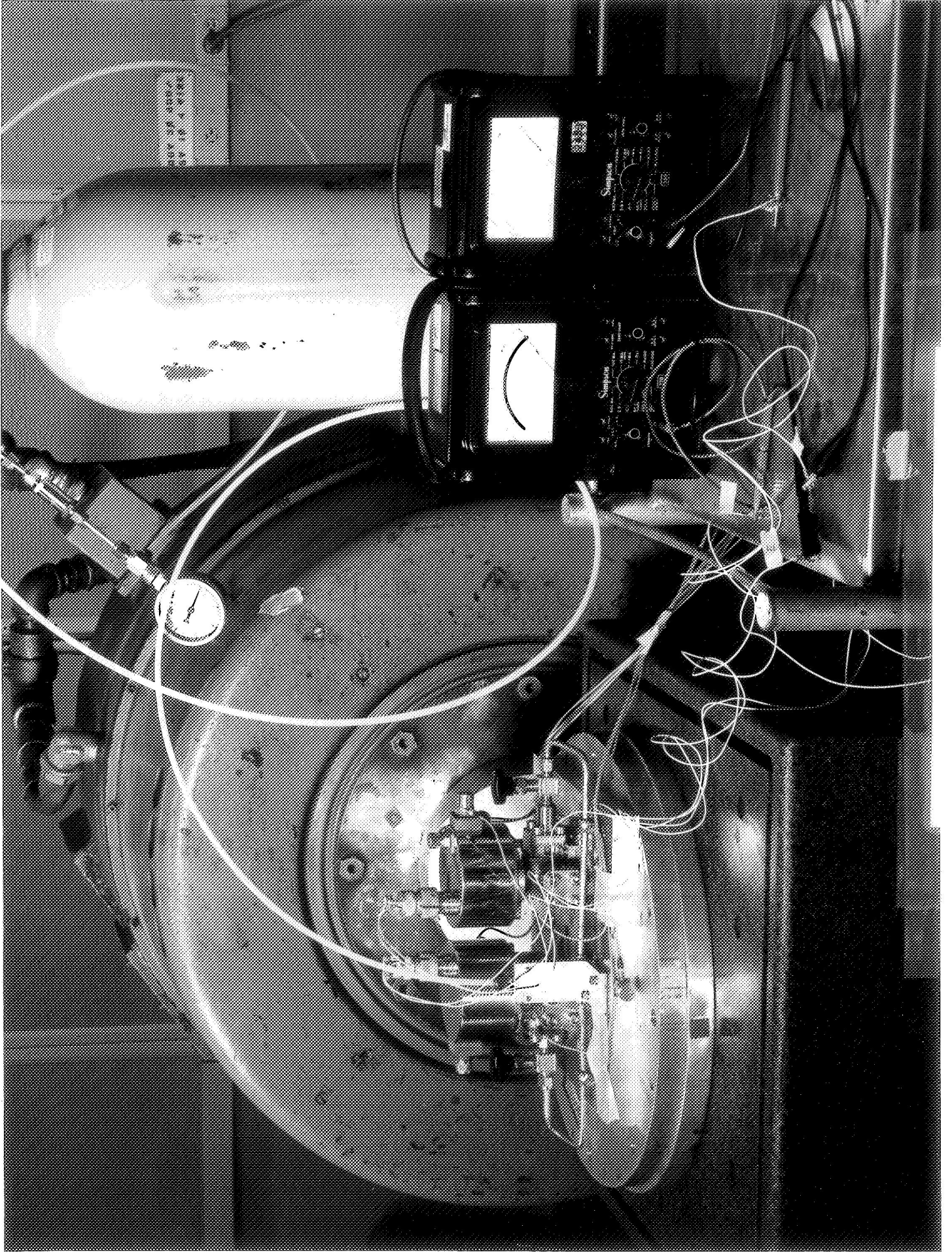

Sinusoidal Vibration Along Port A-B Axis

DEVIATION APPROVAL REQUEST

SHEET 1 OF

1. FOR:  BEFORE-THE-FACT  AFTER-THE-FACT  SUMMARY OF MINOR NONCONFORMANCES

FROM CONTRACTORS:

3. CONTRACT NUMBER:

4. REQUEST NUMBER:

1. *HYDRAULIC RESEARCH AND MFG. CO.*

*NAS 830075*

*001*

5. NOMENCLATURE:

6. NUMBER:

7. REVISION:

8. DATE:

*VALVE*

*39000750-001*

*P*

*2-17-70*

9. NONCONFORMANCE:

10. MRB ACTION NO.:

11. SERIAL NUMBER(S):

12. LOT NUMBER:

13. QUANTITY:

MINOR  MAJOR

*NONE*

*NONE*

*NONE*

*1*

14. SUPPLIER OR SUBCONTRACTOR (GIVE NAME AND ADDRESS):

*HYDRAULIC RESEARCH AND MANUFACTURING CO. 25200 W. RYE CYN. RD. VALENCIA, CAL.*

15. SPECIFIED REQUIREMENTS:

*REF. B/P 39001104 EN. C-6 SEC. C-C.  
.398/.400 X.135 DP.*

16. DESCRIPTION OF DEPARTURE FROM REQUIREMENTS:

*OVERSIZED TO .438 TO A DEPTH OF .035*

*NOTE: THIS PART IS P/N 39001104 HOUSING AND IS A COMPONENT OF END ITEM P/N 39000750-001.*

17. REASON FOR REQUEST AND/OR CORRECTIVE ACTION TAKEN: *THIS CONDITION WILL NOT AFFECT VALVE PERFORMANCE IN FACT THIS CONDITION WILL NEVER BE NOTICED AS THE 39001103 PLUGGING SCREW IS HELIARC WELDED WITH THIS DIA. C/A: MACHINE VENDOR NO LONGER IN BUSINESS.*

REMARKS: *HYD. RES. & MFG. CO. P.O. FROM AVCO IS 754495.*

*Avco has reviewed the above discrepancy and concurs with the reason for request.*

*Des. Eng. R. Rouleau 2/24/70*

*E. C. R. McFarland 2/24/70*

19. CONTRACTOR CERTIFICATION: THE CONTRACTOR HEREBY CERTIFIES THAT THE ABOVE DESCRIBED DEVIATION IS A DEPARTURE FROM THE CONTRACTUAL REQUIREMENTS IN THE QUANTITIES AND/OR CONDITIONS AS STATED ABOVE.

COST ADJUSTMENT (EXPLAIN)  
 NO COST ADJUSTMENT

*QA Administrator*

*[Signature]*

*2-17-70*

20. GOVERNMENT QUALITY ASSURANCE REPRESENTATIVE COMMENTS:

*Reviewed and forwarded to MSFC for action*

*AFGAR*

*Richard R. Stalle 24 Feb 1970*

21. MSFC REVIEW:

ORGANIZATION SYMBOL	REPRESENTATIVE	CONCURRENCE	NON-CONCURRENCE	DATE
<i>S&amp;E-ASTN-EMC</i>	<i>COR - Design</i>	<i>Kenneth B. Anthony</i>		<i>March 2, 70</i>
<i>S&amp;E-QUAL-ATA</i>	<i>NASA - MSFC</i>	<i>Fred J. Dolan</i>		<i>3-2-70</i>

CONTRACTING OFFICER'S REPRESENTATIVE OR OTHER DULY DELEGATED AUTHORITY:

23. CONTRACTING OFFICER: *tests.*

DISAPPROVAL (RECOMMENDED)  
 APPROVAL (RECOMMENDED) (WITH)

APPROVED  
 DISAPPROVED  
 SUBJECT TO CONDITIONS STATED ON MSFC FORM -1.

(WITHOUT) PRICE ADJUSTMENT. \$

*Kenneth B. Anthony* *Mar 2, 70*

*Phillip E. Taylor* *3-2-70*  
Phillip E. Taylor, Contracting Officer

DEVIATION APPROVAL REQUEST

SHEET 1 OF

1. FOR:  BEFORE-THE-FACT  AFTER-THE-FACT *MSFC*  SUMMARY OF MINOR NONCONFORMANCES

FROM CONTRACTOR: HYDRAULIC RESEARCH AND MFG. CO. 3. CONTRACT NUMBER: NAS 830075 4. REQUEST NUMBER: 002

5. NOMENCLATURE: VALVE 6. NUMBER: 39000750-001 7. REVISION: T 8. DATE: 2-17-70

9. NONCONFORMANCE:  MINOR  MAJOR 10. MRB ACTION NO.: NONE 11. SERIAL NUMBER(S): NONE 12. LOT NUMBER: 80862 13. QUANTITY: 2

14. SUPPLIER OR SUBCONTRACTOR (GIVE NAME AND ADDRESS): HYDRAULIC RESEARCH AND MFG. CO. 25200 W. RYE CYN. RD. VILLENCA, CAL.

15. SPECIFIED REQUIREMENTS:  
 REF. B/P 3900112 ZN C-5 & C-7  
 1) .625 / .630 DIA. (ZN C-5)  
 2) 1.242 / 1.244 DIA. (ZN C-7)  
 NOTE: THIS PART IS P/N 3900112 PEPET AND IS A COMPONENT OF END ITEM T/PN 39000750-001

16. DESCRIPTION OF DEPARTURE FROM REQUIREMENTS:  
 1) (2) PIECES ARE UNDERSIZED TO .623 DIA.  
 2) (1) PIECE IS UNDERSIZED TO 1.241 / 1.243 ALSO CUT OF ROUND.

17. REASON FOR REQUEST AND/OR CORRECTIVE ACTION TAKEN: THESE CONDITIONS WILL NOT AFFECT VALVE PERFORMANCE, C/A: MACHING VENDOR CONTACTED AND CORRECTIVE ACTION RECEIVED THAT CONDITIONS A RESULT OF OPERATOR ERROR AND THAT FUTURE PARTS SHALL MEET DVG. REQUIREMENTS.

18. REMARKS: HYD. RES. AND MFG. CO. P/O FROM AVCO IS 754495.  
AVCO Remarks:  
 Avco has reviewed the above discrepancy and concurs with the reason for request. Sealing surface of pepet not affected. Des. Eng. R. Rouleau 2/24/70  
 S.C. R. Damphousse 2/27/70

19. CONTRACTOR CERTIFICATION: THE CONTRACTOR HEREBY CERTIFIES THAT THE ABOVE DESCRIBED DEVIATION IS A DEPARTURE FROM THE CONTRACTUAL REQUIREMENTS IN THE QUANTITIES AND/OR CONDITIONS AS STATED ABOVE.

COST ADJUSTMENT (EXPLAIN)  
 NO COST ADJUSTMENT  
Q.A. Administrator Richard R. Taylor 2-17-70  
TITLE SIGNATURE OF AUTHORIZED REPRESENTATIVE DATE

20. GOVERNMENT QUALITY ASSURANCE REPRESENTATIVE COMMENTS:  
cc: R. Damphousse 3/11/70  
R. Rouleau Reviewed and forwarded to MSFC for action  
AFCAR Richard R. Taylor 24 Feb 1970  
TITLE SIGNATURE DATE

21. MSFC REVIEW:

ORGANIZATION SYMBOL	REPRESENTATIVE	CONCURRENCE	NON-CONCURRENCE	DATE
<u>S&amp;E-ASTU-EMC</u>	<u>COR-Design</u>	<u>Kenneth B. Authon</u>		<u>March 2, 70</u>
<u>S&amp;E-QUAL-ATA</u>	<u>NASA-MSFC</u>	<u>Philip A. Taylor</u>		<u>3-2-70</u>

22. CONTRACTING OFFICER'S REPRESENTATIVE (OTHER THAN DELEGATED AUTHORITY):  
 DISAPPROVAL (RECOMMENDED)  
 APPROVAL (RECOMMENDED) (WITH) (WITHOUT) PRICE ADJUSTMENT. \$ \_\_\_\_\_  
Kenneth B. Authon Mar 2, 70

23. CONTRACTING OFFICER:  
 APPROVED  
 DISAPPROVED  
 SUBJECT TO CONDITIONS STATED ON MSFC FORM \_\_\_\_\_ -1.  
Philip A. Taylor 3-2-70

DEVIATION APPROVAL REQUEST

K. Sullivan SHEET 1 OF

1. FOR:  BEFORE-THE-FACT  AFTER-THE-FACT  SUMMARY OF MINOR NONCONFORMANCES

2. FROM CONTRACTOR: HYDRAULIC RESEARCH AND MFG. CO. 3. CONTRACT NUMBER: NAS 830075 4. REQUEST NUMBER: 003

5. NOMENCLATURE: VALVE 6. NUMBER: 39000750-001 7. REVISION: P 8. DATE: 2-17-70

9. NONCONFORMANCE:  MINOR  MAJOR 10. MRB ACTION NO.: NONE 11. SERIAL NUMBER(S): NONE 12. LOT NUMBER: NONE 13. QUANTITY: 1

14. SUPPLIER OR SUBCONTRACTOR (GIVE NAME AND ADDRESS):  
HYDRAULIC RESEARCH AND MFG. CO. 25200 W. RYE CYN. RD. VALENCIA, CAL.

15. SPECIFIED REQUIREMENTS:  
REF. B/P 3900114 ZNA-5  
1.443/1.447 DIM.  
 NOTE: THIS PART IS P/N 3900114 SUSPENSION AND IS A COMPONENT OF END ITEM P/N 39000750-001.

16. DESCRIPTION OF DEPARTURE FROM REQUIREMENTS:  
UNDERSIZED TO 1.4418.

17. REASON FOR REQUEST AND/OR CORRECTIVE ACTION TAKEN: THIS CONDITION WILL NOT AFFECT VALVE PERFORMANCE. C/A; MACHINE VENDOR NO LONGER IN BUSINESS.

REMARKS: HYD. RES. & MFG. CO. P.O. FROM AVCO IS 754495.  
Avco has reviewed the above discrepancy and concurs with the reason for request. Poppot stroke not affected, since valve parts are shimmed at assy. Poppot stroke measured in op'n # 40 of the HRC by Test & Insp Procedure.

19. CONTRACTOR CERTIFICATION: THE CONTRACTOR HEREBY CERTIFIES THAT THE ABOVE DESCRIBED DEVIATION IS A DEPARTURE FROM THE CONTRACTUAL REQUIREMENTS IN THE QUANTITIES AND/OR CONDITIONS AS STATED ABOVE.

COST ADJUSTMENT (EXPLAIN)  
 NO COST ADJUSTMENT

Q.A. Administrator Richard R. L'Etalle 2-17-70  
TITLE SIGNATURE OF AUTHORIZED REPRESENTATIVE DATE

20. GOVERNMENT QUALITY ASSURANCE REPRESENTATIVE COMMENTS:  
Reviewed and forwarded to MSFC for action  
AF CAR Richard R. L'Etalle 24 Feb 1970  
TITLE SIGNATURE DATE

21. MSFC REVIEW:

ORGANIZATION SYMBOL	REPRESENTATIVE	CONCURRENCE	NON-CONCURRENCE	DATE
<u>SFE-ASTM-EMC</u>	<u>CoR - Design</u>	<u>Kenneth B. Aubrey</u>		<u>March 2, 70</u>
<u>SFE-QUAL-ATA</u>	<u>NASA / MSFC</u>	<u>Fred Q. Dolan</u>		<u>3-2-70</u>

22. CONTRACTING OFFICER'S REPRESENTATIVE OR OTHER FULLY DELEGATED AUTHORITY:  
 DISAPPROVAL (RECOMMENDED)  
 APPROVAL (RECOMMENDED) (WITH) (WITHOUT) PRICE ADJUSTMENT. \$ \_\_\_\_\_  
Kenneth B. Aubrey Mar 2, 70  
SIGNATURE DATE

23. CONTRACTING OFFICER:  
 APPROVED  
 DISAPPROVED  
 SUBJECT TO CONDITIONS STATED ON MSFC FORM \_\_\_\_\_ -1.  
Phillip H. Taylor 3-2-70  
SIGNATURE DATE



BEFORE-THE-FACT       AFTER-THE-FACT       SUMMARY OF MINOR NONCONFORMANCES

1. CONTRACTOR: Avco Systems Division      3. CONTRACT NUMBER: NAS 830075      4. REQUEST NUMBER: Avco-205

5. DESCRIPTION: e Assy, Latching, Pulse Operated      6. NUMBER: 39000750-001      7. REVISION: R      8. DATE: 5/27/70

9. NONCONFORMANCE: MINOR  MAJOR       10. MRB ACTION NO.: IR #05258      11. SERIAL NUMBER(S): HRC Avco 008 E050093 009 E050094      12. LOT NUMBER: N/A      13. QUANTITY: 2

SUPPLIER OR SUBCONTRACTOR (GIVE NAME AND ADDRESS): Hydraulic Research & Mfg. Co., 25200 W. Rye Cyn Rd., Valencia, California

15. SPECIFIED REQUIREMENTS: 5/16 - 24 UNF 3B Th'ds at Port A - 4 Holes on S/N 008, E050093  
5/16 - 25 UNF 3B Th'd at Port B on hole on S/N 009, E050094

16. DESCRIPTION OF DEPARTURE FROM REQUIREMENTS: 4 Holes accepts No Go TPG 2 to 5 1/2 turns  
1 Hole accepts No Go TPG loosely through red dot on 188 x 45°.

7. REASON FOR REQUEST AND/OR CORRECTIVE ACTION TAKEN: Avco to repair thread on S/N 009, E050094 using helicoil insert (Flight Unit).  
(2) S/N 008, E050093, submitted as is. Condition is considered acceptable to Avco for test (Qual. Unit).

8. REMARKS: HRC to be advised of problem and corrective action requested. Done per Telecon with R. Wood, Quality Rep. @ HRC on 5/27/70.

19. CONTRACTOR CERTIFICATION: THE CONTRACTOR HEREBY CERTIFIES THAT THE ABOVE DESCRIBED DEVIATION IS A DEPARTURE FROM THE CONTRACTUAL REQUIREMENTS IN THE QUANTITIES AND/OR CONDITIONS AS STATED ABOVE.

COST ADJUSTMENT (EXPLAIN)  
 NO COST ADJUSTMENT

Quality Task Mgr. R. M. Tompkinson 5/27/70  
TITLE SIGNATURE OF AUTHORIZED REPRESENTATIVE DATE

20. GOVERNMENT QUALITY ASSURANCE REPRESENTATIVE COMMENTS:  
\* SPC/DB-RECOMMENDS THAT THIS UNIT BE ACCEPTED PROVIDING A POSITIVE IDENTIFICATION IS APPLIED TO UNIT STIPULATING "QUAL TEST UNIT ONLY"  
\* SPC/DB-RECOMMENDS TENTATIVE ACCEPTANCE PENDING SUBMITTAL OF A REWORK PROCEDURE FOR HELICOIL INSTALLATION - James H. Somerville  
AFQAR James H. Somerville 27 May 70  
TITLE SIGNATURE DATE

21. MSFC REVIEW:

ORGANIZATION SYMBOL	REPRESENTATIVE	CONCURRENCE	NON-CONCURRENCE	DATE
S&E-ASIA-LAC	CDR- R. Anthony	✓		MAY 25 70
SEC-QUIP-AFC	James H. Somerville	✓*		JUNE 7 1970
MISE-AMM	AS Somerville	✓		6-8-70

22. CONTRACTING OFFICER'S REPRESENTATIVE OR OTHER DULY DELEGATED AUTHORITY:  
 DISAPPROVAL (RECOMMENDED)  
 APPROVAL (RECOMMENDED) (WITH) (WITHOUT) PRICE ADJUSTMENT. \$ \_\_\_\_\_  
June 15, 70

23. CONTRACTING OFFICER:  
 APPROVED  
 DISAPPROVED  
 SUBJECT TO CONDITIONS STATED ON MSFC FORM \_\_\_\_\_  
Musten A. Linn 6/23/70  
SIGNATURE DATE

1. FOR:  BEFORE-THE-FACT  AFTER-THE-FACT  SUMMARY OF MINOR NONCONFORMANCES

FROM CONTRACTOR: <b>Avco Systems Division</b>	3. CONTRACT NUMBER: <b>NAS 830075</b>	4. REQUEST NUMBER: <b>Avco-006</b>
--	--	---------------------------------------

5. NOMENCLATURE: <b>Valve Assy, Latching, Pulse Operated</b>	6. NUMBER: <b>39000750-001</b>	7. REVISION: <b>R</b>	8. DATE: <b>5/27/70</b>
---	-----------------------------------	--------------------------	----------------------------

9. NONCONFORMANCE: <input checked="" type="checkbox"/> MINOR <input type="checkbox"/> MAJOR	10. MRB ACTION NO.: <b>IR #05155</b>	11. SERIAL NUMBER(S): <b>HRC S/N 010 Avco S/N E050105</b>	12. LOT NUMBER:	13. QUANTITY: <b>1</b>
--	---	--	-----------------	---------------------------

14. SUPPLIER OR SUBCONTRACTOR (GIVE NAME AND ADDRESS):

15. SPECIFIED REQUIREMENTS: (1) Valve Assy QATP SD-200 para 9. 5. 2 pins L to J = 24. 5 to 27. 5 ohms para 9. 5. 3 pins M to K = 24. 5 to 27. 5 ohms para 9. 11. 3 power drain A = 30 + 1. 5 watts para 9. 11. 5 power drain B = 30 + 1. 5 watts (2) 5/16-24 UNF-3B Thread, 4 holes port A.	16. DESCRIPTION OF DEPARTURE FROM REQUIREMENTS: <p style="text-align: center;"><u>Actual Measurements</u></p> 28. 6 ohms 28. 5 ohms 26. 88 watts 26. 60 watts (2) Two holes accept No-Go gauge through and 2 holes accept No-Go gauge 75% through.
---	---

17. REASON FOR REQUEST AND/OR CORRECTIVE ACTION TAKEN:  
 (1) Values within HRC dwg requirements, QATP SD-200 to be revised.  
 (2) Threads to be repaired using helicoil inserts (4 holes)

18. REMARKS: This "DAR" Does Not relieve the contractor from the obligation of meeting the functional requirements of the contract on this valve. ~~XXXXX~~ *FOR*

19. CONTRACTOR CERTIFICATION: THE CONTRACTOR HEREBY CERTIFIES THAT THE ABOVE DESCRIBED DEVIATION IS A DEPARTURE FROM THE CONTRACTUAL REQUIREMENTS IN THE QUANTITIES AND/OR CONDITIONS AS STATED ABOVE.

COST ADJUSTMENT (EXPLAIN)  
 NO COST ADJUSTMENT

Quality Task Manager *D. M. Dampousse* 5/27/70  
TITLE SIGNATURE OF AUTHORIZED REPRESENTATIVE DATE

20. GOVERNMENT QUALITY ASSURANCE REPRESENTATIVE COMMENTS:  
*\* (Ref - Item No. 2 - Block 15) Recommend Tentative Approval with Provisional Acceptance Pending Submittal of a Repair Procedure for Helicoil Installation - James H. Sholly, (MCM)*  
*(See remarks column above)* *AFQAR* *James H. Sholly* 27 May 70  
TITLE SIGNATURE DATE

21. MSFC REVIEW:

ORGANIZATION SYMBOL	REPRESENTATIVE	CONCURRENCE	NON-CONCURRENCE	DATE
S&E-ASTO-EMC	Col. K. Anthony	✓		5/28/70
S&E-QUAL-REC	James H. Sholly	✓		6-2-70
S&E-QUAL-ATA	Fred J. Delam	✓		
POISE-ADM	J. Sholly			6-8-70

22. CONTRACTING OFFICER'S REPRESENTATIVE/ OR OTHER DULY DELEGATED AUTHORITY: <input type="checkbox"/> DISAPPROVAL (RECOMMENDED) <input checked="" type="checkbox"/> APPROVAL (RECOMMENDED) (WITH) (WITHOUT) PRICE ADJUSTMENT. \$ _____ <u><i>Kenneth B. Anthony</i></u> <u>June 15, 70</u> <small>SIGNATURE DATE</small>	23. CONTRACTING OFFICER: <input checked="" type="checkbox"/> APPROVED <input type="checkbox"/> DISAPPROVED <input type="checkbox"/> SUBJECT TO CONDITIONS STATED ON MSFC FORM _____ -1. <u><i>Walter A. Lenoir</i></u> <u>6/23/70</u> <small>SIGNATURE DATE</small>
--	--

1. FOR:  BEFORE-THE-FACT  AFTER-THE-FACT  SUMMARY OF MINOR NONCONFORMANCES

2. FROM CONTRACTOR: HYDRAULIC RESEARCH & MFG. COMPANY  
25200 West Rye Cyn Rd., Valencia, Calif. 91355  
3. CONTRACT NUMBER: NAS 880075  
4. REQUEST NUMBER: 008

5. NOMENCLATURE: Valve Assy., Latching  
6. NUMBER: 39000750-001  
7. REVISION: R  
8. DATE: 7-23-70

9. NONCONFORMANCE:  MINOR  MAJOR  
10. MRB ACTION NO.: AVCO Insp. Rept. #05402  
11. SERIAL NUMBER(S): 011 & 012  
12. LOT NUMBER: --  
13. QUANTITY: 2

14. SUPPLIER OR SUBCONTRACTOR (GIVE NAME AND ADDRESS):  
HYDRAULIC RESEARCH & MANUFACTURING COMPANY  
25200 West Rye Canyon Road, Valencia, California 91355

15. SPECIFIED REQUIREMENTS:  
Ref. Dwg. 39001118 (Ports A & B)  
The 5/16-24 UNF-3B threaded holes must conform to thread specification.  
Note: 39001118 is P/N of Ports components in which discrepancies exist.  
16. DESCRIPTION OF DEPARTURE FROM REQUIREMENTS:  
S/N 011 & S/N 012 (Ports A & B)  
MS 21209-F5-15 Helicoils have been installed in ports "A" and "B"

17. REASON FOR REQUEST AND/OR CORRECTIVE ACTION TAKEN:  
Reason for Request: Instructions from AVCO for installation of Helicoils.

18. REMARKS:  
Reason for Helicoil installation: Threads were oversized on the pitch and/or minor diameters.  
*Acceptable to SFE-QUAL pending form, fit, and functions checks at MSFC 9/14/70*

19. CONTRACTOR CERTIFICATION: THE CONTRACTOR HEREBY CERTIFIES THAT THE ABOVE DESCRIBED DEVIATION IS A DEPARTURE FROM THE CONTRACTUAL REQUIREMENTS IN THE QUANTITIES AND/OR CONDITIONS AS STATED ABOVE.  
 COST ADJUSTMENT (EXPLAIN)  
 NO COST ADJUSTMENT  
Quality Assurance Administrator *Bobby L. [Signature]* 7-23-70

20. GOVERNMENT QUALITY ASSURANCE REPRESENTATIVE COMMENTS:  
Recommend approval - forwarded for your action.  
*cc R. [Signature] 9/29* *AFCAR* *R. R. [Signature]* 8/20/70

21. MSFC REVIEW:

ORGANIZATION SYMBOL	REPRESENTATIVE	CONCURRENCE	NON-CONCURRENCE	DATE
SFE-QUAL-ATA	James A. Hays	Provisional		9-15-70
PM/SE-ATM	David E. Snoddy			9-23-70

22. CONTRACTING OFFICER'S REPRESENTATIVE OR OTHER DULY DELEGATED AUTHORITY:  
 DISAPPROVAL (RECOMMENDED)  
 APPROVAL (RECOMMENDED) (WITH) (WITHOUT) PRICE ADJUSTMENT. \$  
*Kenneth G. Anthony* Sept 23, 70  
23. CONTRACTING OFFICER:  
 APPROVED  
 DISAPPROVED  
 SUBJECT TO CONDITIONS STATED ON MSFC FORM  
*Charles C. [Signature]* 9-23-70  
CHAR. [Signature] C. L. INN

DEVIATION APPROVAL REQUEST

SHEET 1 OF

1. FOR:  BEFORE-THE-FACT  AFTER-THE-FACT  SUMMARY OF MINOR NONCONFORMANCES

2. FROM CONTRACTOR:  
Avco Systems Division, Lowell Industrial Park,  
Lowell, Massachusetts 01851

3. CONTRACT NUMBER:  
NAS 8-30075

4. REQUEST NUMBER:  
Avco-010

5. NOMENCLATURE:  
Flow Diverter Valve

6. NUMBER:  
39000750-001  
MSFC 20M42517

7. REVISION:  
S  
C

8. DATE:  
2 Sept. 1970

9. NONCONFORMANCE:  
 MINOR  MAJOR

10. MRB ACTION NO.:

11. SERIAL NUMBER(S):  
007, 008, 009, 010, 011,  
012, 013, 014

12. LOT NUMBER:

13. QUANTITY:  
eight (8)

14. SUPPLIER OR SUBCONTRACTOR (GIVE NAME AND ADDRESS):  
Hydraulic Research and Manufacturing Co., 25200 West Rye Canyon Road,  
Valencia, California 91355

15. SPECIFIED REQUIREMENTS:  
1. Coil transient voltage - specification 20M42517, Rev. C., para. 4.3.4.15. Peak transient voltage not to exceed 150% of rated voltage.  
2. Qualification Test Procedure-STP-SSD-1024, para. 5.6.5. Transient voltage of 72vdc applied for 5 microseconds.

16. DESCRIPTION OF DEPARTURE FROM REQUIREMENTS:  
1. S/N 007, 008, 009, 010, 011, 012, 013, 014. \*See Remarks. Peak transient voltage on S/N 007 and 008 with 28VDC rated voltage is 50-52 volts. Should be 42 volts.  
2. Transient voltage of 72 VDC applied for approximately 2 microseconds and remaining 3 microseconds at approximately 20 VDC.

17. REASON FOR REQUEST AND/OR CORRECTIVE ACTION TAKEN:  
1. Request to use as is. All valves are assembled and covers welded in place. Requires major rework to correct discrepancy. 2. Reduced pulse width is result of coupling effect between valve coil (inductive load) and pulse generator which limits pulse width at full ampli-

REMARKS:  
\*Peak transient voltage of 50-52 VDC has been measured on S/N 007 and 008 (qualification units) only. Due to design and construction, the same results are anticipated on all other units. This test is not part of acceptance testing.

19. CONTRACTOR CERTIFICATION: THE CONTRACTOR HEREBY CERTIFIES THAT THE ABOVE DESCRIBED DEVIATION IS A DEPARTURE FROM THE CONTRACTUAL REQUIREMENTS IN THE QUANTITIES AND/OR CONDITIONS AS STATED ABOVE.

COST ADJUSTMENT (EXPLAIN)  
 NO COST ADJUSTMENT  
PROJECT ENGR. J. H. Magala  
G. S. Ray, Engr  
TITLE SIGNATURE OF AUTHORIZED REPRESENTATIVE  
7/31/70 9/3/70  
DATE DATE

20. GOVERNMENT QUALITY ASSURANCE REPRESENTATIVE COMMENTS:  
Forwarded for your review and action  
AFGAR  
Richard P. L'Etienne  
TITLE SIGNATURE DATE  
1/3/70

21. MSFC REVIEW:

ORGANIZATION SYMBOL	REPRESENTATIVE	CONCURRENCE	NON-CONCURRENCE	DATE
SE-QUAL-E	R. W. Smithfield			10/6/70
SE-MSFC-SE	[Signature]	(See Attachment)		11/30/70
	[Signature]			

22. CONTRACTING OFFICER'S REPRESENTATIVE OR OTHER DULY DELEGATED AUTHORITY:  
 DISAPPROVAL (RECOMMENDED)  
 APPROVAL (RECOMMENDED) (WITH) (WITHOUT) PRICE ADJUSTMENT. \$ 0.00  
[Signature] DATE

23. CONTRACTING OFFICER:  
 APPROVED  
 DISAPPROVED  
 SUBJECT TO CONDITIONS STATED ON MSFC FORM -1.  
[Signature] DATE

Mr. Morgan

DEVIATION APPROVAL REQUEST

1. FOR:  BEFORE-THE-FACT  AFTER-THE-FACT  SUMMARY OF MINOR NONCONFORMANCES JUN 10 1970

2. FROM CONTRACTOR: HYDRAULIC RESEARCH AND MFG. CO. 3. CONTRACT NUMBER: NAS 830075 4. REQUEST NUMBER: 004

NOMENCLATURE: VALVE 6. NUMBER: 39000750-001 7. REVISION: 8. DATE:

9. NONCONFORMANCE:  MINOR  MAJOR 10. MRB ACTION NO.: NONE 11. SERIAL NUMBER(S): NONE 12. LOT NUMBER: 80862 13. QUANTITY: 2

14. SUPPLIER OR SUBCONTRACTOR (GIVE NAME AND ADDRESS): HYDRAULIC RESEARCH AND MFG. CO. 25200 W. RYE CYN. RD. VALENCIA, CAL.

15. SPECIFIED REQUIREMENTS: REF. B/P39001112 ZN C-3 SEC. A-A.  
1.) 

⊕	A	⊕	.003 TOTAL	⊕
-	B	DIA	-	

  
NOTE: THIS PART IS P/N 39001112 POPPET AND IS A COMPONENT OF END ITEM P/N 39000750-001 VALVE.

16. DESCRIPTION OF DEPARTURE FROM REQUIREMENTS:  
1.) THE 'B' DIA. IS OFF LOCATION TO 'A' FROM .005 TO .008

17. REASON FOR REQUEST AND/OR CORRECTIVE ACTION TAKEN: THIS DISCREPANCY WILL NOT AFFECT VALVE PERFORMANCE. C/A: MACHINE VENDOR, PRECISION MACHINE CO., WILL ON FUTURE PARTS, MANUFACTURE AND INSPECT THIS DIMENSION USING A FIXTURE.

REMARKS: HYD. RES. AND MFG. CO. P.D. FROM AVCO IS 754495.  
AVCO COMMENT:  
Housing, suspension, & poppet have been fit checked and there is no interference.  
AVCO Q.C. R.M. Damphousse 5/27/70  
AVCO Eng. R. Paulsen 5/27/70

19. CONTRACTOR CERTIFICATION: THE CONTRACTOR HEREBY CERTIFIES THAT THE ABOVE DESCRIBED DEVIATION IS A DEPARTURE FROM THE CONTRACTUAL REQUIREMENTS IN THE QUANTITIES AND/OR CONDITIONS AS STATED ABOVE.  
 COST ADJUSTMENT (EXPLAIN)  
 NO COST ADJUSTMENT  
Q.A. ADMINISTRATOR Bobby R. Hood 5-21-70  
TITLE SIGNATURE AUTHORIZED REPRESENTATIVE DATE

20. GOVERNMENT QUALITY ASSURANCE REPRESENTATIVE COMMENTS:  
AFGAR Gerard J. Villano 27-May 70  
TITLE SIGNATURE DATE

21. MSFC REVIEW:

ORGANIZATION SYMBOL	REPRESENTATIVE	CONCURRENCE	NON-CONCURRENCE	DATE
<u>AE-ASTN-EN C</u>	<u>GOR Design Kenneth Anthony</u>		<input checked="" type="checkbox"/>	<u>June 4/70</u>

22. CONTRACTING OFFICER'S REPRESENTATIVE OR OTHER DULY DELEGATED AUTHORITY:  
 DISAPPROVAL (RECOMMENDED)  
 APPROVAL (RECOMMENDED)(WITH) (WITHOUT) PRICE ADJUSTMENT. \$  
Kenneth b. Anthony June 4/70  
SIGNATURE DATE

23. CONTRACTING OFFICER:  
 APPROVED  
 DISAPPROVED  
 SUBJECT TO CONDITIONS STATED ON MSFC FORM -1.  
Charles C. Linn  
Charles C. Linn, Contracting Officer 6-5-70  
SIGNATURE DATE

1. FOR:  BEFORE-THE-FACT  AFTER-THE-FACT  SUMMARY OF MINOR NONCONFORMANCES

FROM CONTRACTOR: Avco Systems Division  
 3. CONTRACT NUMBER: NAS 8-30075  
 4. REQUEST NUMBER: Avco-009

5. NOMENCLATURE: Valve Assy, Latching, Pulse Operated  
 6. NUMBER: 39000750-001  
 7. REVISION: R  
 8. DATE: 9-2-70

9. NONCONFORMANCE:  MINOR  MAJOR  
 10. MRB ACTION NO.: IR #05481  
 11. SERIAL NUMBER(S): HRC Avco  
 014 G050126  
 013 G050125  
 12. LOT NUMBER: N/A  
 13. QUANTITY: 2

14. SUPPLIER OR SUBCONTRACTOR (GIVE NAME AND ADDRESS):  
 Hydraulic Research & Mfg. Co., 25200 W. Rye Cyn Rd., Valencia, California

15. SPECIFIED REQUIREMENTS:				16. DESCRIPTION OF DEPARTURE FROM REQUIREMENTS:			
S/N 014-Port 'B'				S/N 014-Port 'B'			
Hole 1	Hole 2	Hole 3	Hole 4	Hole 1	Hole 2	Hole 3	Hole 4
X Dim .438	X Dim .438	X Dim .876	X Dim .876	X Dim-.0027	X Dim+.0018	X Dim-.0042	X Dim-.0067
Y Dim .876	Y Dim .438	Y Dim .438	Y Dim .876	Y Dim-.0065	Y Dim -.0047	Y Dim-.001	Y Dim-.0063
S/N 014-Port 'A'				S/N 014-Port 'A'			
Hole 1	Hole 2	Hole 3	Hole 4	Hole 1	Hole 2	Hole 3	Hole 4
X Dim .876	X Dim .876	X Dim .438	X Dim .438	X Dim+.0053	X Dim+.0001	X Dim-.0033	X Dim+.0007
Y Dim .438	Y Dim .876	Y Dim .876	Y Dim .438	Y Dim-.0019	Y Dim-.0047	Y Dim-.0015	Y Dim+.0038
S/N 013 No marks on face of Port 'A'				S/N 013 Nick on face near edge at 'A' Port .040 Dia x .030 Deep			

17. REASON FOR REQUEST AND/OR CORRECTIVE ACTION TAKEN:  
 S/N 014 - Hole location conforms to Nasa/MSFC 20M 42522, which allows greater tolerance than HRC Dwg. 39001118  
 S/N 013 - Nick on edge of Port beyond sealing area, and will not prevent sealing at flange.

REMARKS:  
 Acceptable <sup>None</sup> TO S&E-QUAL Pending Form FIT & FUNCTION TEST AT MSFC.  
 JAH 9-18-70

19. CONTRACTOR CERTIFICATION: THE CONTRACTOR HEREBY CERTIFIES THAT THE ABOVE DESCRIBED DEVIATION IS A DEPARTURE FROM THE CONTRACTUAL REQUIREMENTS IN THE QUANTITIES AND/OR CONDITIONS AS STATED ABOVE.

COST ADJUSTMENT (EXPLAIN)  
 NO COST ADJUSTMENT

Q. C. Project Engineer *J. H. Magala* 9/3/70  
 TITLE SIGNATURE OF AUTHORIZED REPRESENTATIVE DATE

20. GOVERNMENT QUALITY ASSURANCE REPRESENTATIVE COMMENTS:  
 Forwarded for your review and action  
 cc: R. Rouleau 9/29  
*AFQAR* Richard R. L'Etienne 9/3/70  
 TITLE SIGNATURE DATE

21. MSFC REVIEW:

ORGANIZATION SYMBOL	REPRESENTATIVE	CONCURRENCE	NON-CONCURRENCE	DATE
S&E-QUAL-ATA	James A. Harp	Provisional ✓		9-18-70
PMISE-ATM	David E. Dudley	✓		9-23-70

CONTRACTING OFFICER'S REPRESENTATIVE OR OTHER DULY DELEGATED AUTHORITY:  
 DISAPPROVAL (RECOMMENDED)  
 APPROVAL (RECOMMENDED) (WITH) (WITHOUT) PRICE ADJUSTMENT. \$

*Kenneth G. Anthony* 9/23/70  
 SIGNATURE DATE

23. CONTRACTING OFFICER:  
 APPROVED  
 DISAPPROVED  
 SUBJECT TO CONDITIONS STATED ON MSFC FORM -1.

*Charles C. Lynn* 9-23-70  
 CHARLES C. LYNN DATE

1. FOR:  BEFORE-THE-FACT  AFTER-THE-FACT  SUMMARY OF MINOR NONCONFORMANCES

2. FROM CONTRACTOR: Avco Systems Division 3. CONTRACT NUMBER: NAS 830075 4. REQUEST NUMBER: Avco 007

5. NOMENCLATURE: Valve Assy, Latching, Pulse Operated 6. NUMBER: 39000750-001 7. REVISION: R 8. DATE: 6/5/70

9. NONCONFORMANCE:  MINOR  MAJOR 10. MRB ACTION NO.: IR #05267 11. SERIAL NUMBER(S): HRC S/N 007 Avco E050106 12. LOT NUMBER: 13. QUANTITY: 1

14. SUPPLIER OR SUBCONTRACTOR (GIVE NAME AND ADDRESS):

15. SPECIFIED REQUIREMENTS: (1) 5/16-24 UNF-3B Thread, 4 Holes Pad A. (2) Surface finish on Pad B should be 32 16. DESCRIPTION OF DEPARTURE FROM REQUIREMENTS: (1) 5/16-24 UNF 3B Thread (4 Holes) accepts No-Go gauge from 4 to 8 1/2 turns. (2) Surface finish on Pad B is 55

17. REASON FOR REQUEST AND/OR CORRECTIVE ACTION TAKEN: (1) Threads to be used as is. (This is a non-flight unit to be used for qualification tests.) (2) Pad B is to be reworked to correct surface finish.

18. REMARKS: None

19. CONTRACTOR CERTIFICATION: THE CONTRACTOR HEREBY CERTIFIES THAT THE ABOVE DESCRIBED DEVIATION IS A DEPARTURE FROM THE CONTRACTUAL REQUIREMENTS IN THE QUANTITIES AND/OR CONDITIONS AS STATED ABOVE.  COST ADJUSTMENT (EXPLAIN)  NO COST ADJUSTMENT Quality Task Manager TITLE Signature of Authorized Representative: [Signature] DATE: 6/15/70

20. GOVERNMENT QUALITY ASSURANCE REPRESENTATIVE COMMENTS: CC R. Royseau 2/2/71 AFQAR TITLE Signature of Representative: [Signature] DATE: 6/15/70

21. MSFC REVIEW: Table with columns: ORGANIZATION SYMBOL, REPRESENTATIVE, CONCURRENCE, NON-CONCURRENCE, DATE

22. CONTRACTING OFFICER'S REPRESENTATIVE OR OTHER DULY DELEGATED AUTHORITY:  DISAPPROVAL (RECOMMENDED)  APPROVAL (RECOMMENDED) (WITH) (WITHOUT) PRICE ADJUSTMENT. \$ [Signature] Kenneth G. Anthony DATE: Jan 29-71

23. CONTRACTING OFFICER:  APPROVED  DISAPPROVED  SUBJECT TO CONDITIONS STATED ON MSFC FORM -1. [Signature] DATE: 1-29-71

Equipment Nomenclature: FLOW PATH SELECTOR VALVE

Manufacturer: HYDRAULIC RESEARCH

Model Number: 20M42517

Serial Number: 013

Procedure: Apply 28 volt power to test specimen through the same type power switching device used in the system. Record transients developed across the Power Distribution Simulator network during "ON" and "OFF" switching. Turn specimen "ON" and record operational transients across PDS network. Record both steady-state and mode change transients.

Power Switching Devices: ECN - ATM THERMAL CONTROL

Turn On transient:  1.4V @ 20ms.

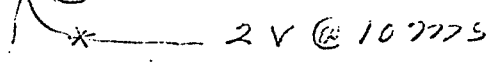
Turn Off transient:  \* 2V @ 10ms.

Operational: N/A

If too complex to define, attach photograph.

Remarks: \* AC SCOPE COUPLING  
25 OHM LOAD IN VIEW NETWORK (1.7VOLT DROP)

Test conducted by E. ENGLAND

Test Date 11-25-70

Responsible Engineer KEN. ANTHONY

Qualified YES W<sup>3</sup> 11-25-70

Waiver Status N/A

The Flow Diverter Valve passed 50M02477 transient specification.