

N71-22812

NASA CR-111858

THE PERKIN-ELMER CORPORATION  
AEROSPACE DIVISION  
2855 Metropolitan Place, Pomona, California, 91767

FINAL REPORT  
INLET LEAK STUDY  
VOLUME 4 OF 6  
FOR  
COMBINED STUDY PROGRAM

By George V. Moore  
And  
Burton W. Scott

March 1971

**CASE FILE  
COPY**

Contract NAS1-9469  
SPO Number 30006

Prepared for  
NATIONAL AERONAUTICS AND SPACE ADMINISTRATION  
LANGLEY RESEARCH CENTER  
Langley Station  
Hampton, Virginia 23365

THE PERKIN-ELMER CORPORATION  
AEROSPACE DIVISION  
2855 Metropolitan Place, Pomona, California 91767

FINAL REPORT  
INLET LEAK STUDY  
VOLUME 4 OF 6  
FOR  
COMBINED STUDY PROGRAM

By George V. Moore  
And  
Burton W. Scott

March 1971

Approved By: G. V. Moore Date 3/17/71  
G. V. Moore

Approved By: B. W. Scott Date 3/18/71  
B.W. Scott, Project Engineer

Approved By: B. F. Bicksler Date 3/17/71  
B.F. Bicksler, Project Manager

Approved By: M. R. Ruecker Date 18 Mar '71  
M.R. Ruecker, Manager Space Physics

Approved By: W. C. Qua Date 18 Mar 71  
W.C. Qua, Program Manager

Contract NAS1-9469

SPO Number 30006

Prepared for  
NATIONAL AERONAUTICS AND SPACE ADMINISTRATION  
LANGLEY RESEARCH CENTER

Langley Station  
Hampton, Virginia 23365

## ABSTRACT

A program was conducted in which an instrument system concept was studied to optimize the application of a mass spectrometer as a sensor for monitoring the primary atmospheric constituents, as well as atmospheric contaminants, on board a manned spacecraft. The program was divided into six individual studies representing the primary system parts complementing the spectrometer: A Carbon Monoxide Accumulator Cell (Volume 1), an Ion Pump (Volume 2), an Ion Pump Power Supply (Volume 3), an Inlet Leak (Volume 4), an Ion Source (Volume 5), and an Undersea Atmospheric Analyzer (Volume 6). The principle goal of the combined study program was the achievement of an instrument concept of minimum power, weight and size without compromising the minimum detection limits of the instrument.

## TABLE OF CONTENTS

	<u>Page</u>
ABSTRACT	ii
SUMMARY	1
INTRODUCTION	1
ADJUSTABLE LEAK INVESTIGATION	2
Expanding Tube Configuration	4
Piston Drive Leak Configuration	8
SINTERED LEAK DEVELOPMENT	14
Fabrication of Sintered Leaks	15
Test Procedures	16
METAL MEMBRANE LEAKS WITH SUBMICRON-SIZE PORES	18
Temperature Response	19
Long Term Stability	23
CONCLUSIONS	24
APPENDIX A - DESIGN ANALYSIS OF BALL LEAK	26
Introduction	26
ANALYSIS	26

## LIST OF ILLUSTRATIONS

	<u>Page</u>
1. Ball Leak Assembly Developed in NAS1-6387	33
2. Leak Assembly, Expanding Tube	34
3. Leak Assembly, Piston Drive	35
4. Modified Valve Body With Sintered Leak Welded in Place	36
5. Apparatus for Measuring Time Response and Long-Term Stability of Mott Sintered Leak	37

## TABLE OF CONTENTS (Cont)

	<u>Page</u>
6. Conductance of Sintered Leak at Pressure Differentials Below 1 Atmosphere	38
7. Temperature Coefficient of Sintered Leak	39
8. Time Response of Filters and Leak Assembly	40
9. Conductance and Time Delay of Molecular Flow Through a Channel $d$ Microns, Diameter, $l$ mm Long	41
10. Long-Term Test of Sintered Leak	42
11. Graph (Design Analysis of Ball Leak) of Geometry Factor $K$ vs Leak Height to Width Ratio $t/w$	43

## SUMMARY

Over all, the direct entry inlet leak development has been a success. The adjustable ball leak which was built and tested, proved the feasibility of an adjustable direct entry leak. Two other adjustable leak configurations, which could exhibit adjustability and stability characteristics that are superior to those of the ball leak, were conceived and analyzed. These two new configurations are designated as the expanding tube and piston drive configurations, respectively. The analysis indicated that these two configurations should exhibit improved adjustability and stability when subjected to vibration or temperature change.

Significant progress was also made in the development of a fixed conductance direct entry inlet leak. An extended series of tests were performed on leaks made with pellets of sintered stainless powder. These sintered pellet leaks show molecular flow characteristics up to one atmosphere and can be fabricated in a wide range of conductances. The tests performed indicate that these extremely rugged leaks are ideal for sampling cabin atmospheres in the presences of dust and moisture. A temperature change from twenty to seventy degrees centigrade increases the conductance only eight percent. Dust and cigarette smoke did not plug it even slightly. At the end of the 1,710 hour test, the only procedure that changed the conductance was several days exposure to air so moist that droplets condensed on the surface of the sintered pellet. Time response tests indicate that responses of a few tenths of a millisecond can be achieved. Another material, a metal membrane with submicron pores, having good potential for extremely fast time response was also investigated. Due to the small amount of material available at this time, only limited tests could be performed on these membranes.

## INTRODUCTION

The goal of the direct entry inlet leak development was to provide a molecular flow of sample gas from a sample environment of approximately one-half to one atmosphere into the mass spectrometer ion source, at a maximum pressure of about  $2 \times 10^{-4}$  torr. The advantage of such a system is that it requires no auxiliary pump, such as that required for the existing capillary line pressure divider system. Molecular flow assures a linear relation between the pressure in the ion source and the pressure in the sample environment; and molecular flow allows each of the constituents in the sample gas mixture to flow independently of each other when they enter the ion source. As a result, the measurement of one constituent in the mixture is not affected by the amount of the other components that are present.

## ADJUSTABLE LEAK INVESTIGATION

In order to obtain molecular flow it is generally required that the mean free path of the gas on the high pressure side of the leak be greater than the diameter of the leak opening; assuming a leak of cylindrical cross section. This can be used as a criterion for the minimum cross sectional dimension of the leak for other geometries. Actually, if the more general Knudsen flow equation is carefully examined, it is found that shorter mean free paths can be tolerated before there is a significant deviation from molecular flow. (This work has been presented in the final report on Contract NAS1-6387.) In fact,  $D \leq 3 \lambda$  appears to be an acceptable criteria, rather than  $D \leq 1/3 \lambda$ . Assuming that the leak should maintain its properties to pressures as high as one atmosphere (for ground checkout, if nothing else), then the following computation (for air) shows the minimum dimensions involved:

$$\lambda \approx \frac{0.05}{P_{\text{units}}} = \frac{0.05}{760_{\text{torr mm}}} = 6.58 \times 10^{-5} \text{ mm}$$

$$D \leq 3 \lambda = 3 \times 6.58 \times 10^{-5} = 1.974 \times 10^{-4} \text{ mm}$$

or approximately  $D \leq 0.2 \mu$ .

This represents an extremely small dimension, particularly when mechanically adjustable components are utilized to establish it.

In addition to the small leak dimensions, which must be obtained in order to have molecular flow, there are several other criteria that are also important. Without any attempt to put them in their order of importance, the following items are discussed.

The leak must have a nominal conductance of ( $C_0$ ) of about  $1 \times 10^{-5}$  cubic centimeters per second in order to be compatible with the flow requirements of the mass spectrometer. If  $P_0 C_0 \approx p_p S_p$  and the sample environment pressure ( $P_0$ ) is 400 torr, the internal pressure of the ion pump, which is utilized to maintain the system pressure, ( $p_p$ ) is held to  $1 \times 10^{-6}$  torr, and the speed of the ion pump ( $S_p$ ) is four liters per second, then the above stated conductance is obtained. The leak should be physically small and rugged in order to withstand the environment of space flight. It should be bakeable to 250 degrees centigrade or higher in order to withstand a typical mass spectrometer bakeout cycle when it is attached to the analyzer. It should have a reasonably small temperature coefficient so that conductance variations over the environmental temperature range do not cause prohibitive

internal pressure variations. Also, the leak should not, if possible, plug easily in the expected environments. Every attempt is made to maintain the sample cleanliness at high levels by filtration, but some applications prohibit a high degree of filtering.

It is important to note that the more recent application of the closed loop electronics systems to the Two Gas Sensor type of mass spectrometer has diminished the requirement for invariability of leak conductance. This results from the fact that a leak conductance change causes a common mode change in the mass spectrometer outputs, which is compensated for by the closed loop operation. This means that previous goals of one or two percent variation in leak conductance due to mechanical, thermal and contamination causes can be relaxed, perhaps by as much as a factor of ten. This does not imply that the task of leak development has been reduced to the point where it no longer requires a significant effort, but it does mean that the likelihood of achieving all of the objectives has been significantly improved. The requirements are still imposing.

In addition to these considerations, the leak must, for some applications, have a rapid time response. For example, metabolic measurements in which a breath by breath analysis is required, demand a system time response of the order 100 milliseconds and a corresponding leak time response of one-half to one greater than this value, depending upon the balance of the system. It is recognized, however, that this is not ultimate, insofar as this type of analysis is concerned, and it may not be necessary to achieve this level immediately. Nonetheless, the leak time response is an important factor which must be considered in the development. In fact, it is one of the primary reasons that the adjustable leak concept was continued even though the sintered leak appeared to have clear cut advantages in the other areas. It was suspected that the length and fineness of the passages in the sintered material would lead to relatively long time constants. This was proven to be the case as will be seen later in this report.

Another area that must impart the leak design is the ease with which it adapts to the mass spectrometer. This requirement is twofold; first, the interface with the ion source; and second, the interface with the sample transport line. The latter is of particular importance where a close coupled sample shutoff valve is to be used to close off the sample volume while having a minimum trapped volume. As later tests on another contract revealed, the exact geometry of the interface between the transport line and the inlet leak is extremely important if the time response of the inlet system is to be minimized. Therefore, it is essential that the leak allow the sample transport lines to be placed immediately adjacent to the leak restriction.



The small size of the leak is important for another reason, for some applications, such as metabolic analysis, it is necessary to heat the leak in order to prevent condensation and possible plugging of the leak. By having a small leak, heating with a low power input is facilitated.

Whereas present applications do not require adjustability of the leak conductance, this does appear to offer some advantages over a fixed conductance leak. In the manufacture of leaks an adjustable type can presumably be set to any required value, whereas a fixed leak may be subject to rejection if it does not fall within a specified tolerance.

The ball leak feasibility model, developed on NASA Contract NAS1-6387, proved that it was feasible to make this type of leak. However, testing of the ball leak indicated that the leak design needed improvement in the area of thermal and vibrational stability. It was also found that it was somewhat difficult to adjust the leak to a given conductance setting. With the help of the test data, a critical design analysis of the ball leak was made, which showed that it was unlikely that this particular design configuration (shown in Figure 1) could be made to perform to complete satisfaction. The analysis showed that the ball leak was basically a force and stress oriented device, since the leak elements were necessarily small, only small forces could be applied with the intricate adjustment mechanism. Because of the high stress required to deform the ball and seat leak elements an extremely small seat area was required. Unfortunately, this meant that small changes in the forces applied to the ball and seat, caused by vibration or thermal expansion, resulted in relatively large changes in the induced stress and deformation. (See the Design Analysis of Ball Leak presented in Appendix A.) It was decided that a backup design for the sintered metal leak was still needed. For this reason, a design effort was undertaken to develop an alternate configuration which could solve the problems encountered with the ball leak design. Several design concepts were considered and partially analyzed in an effort to select the concept or concepts that appeared to show significant promise. This design effort yielded two approaches that seem to show considerable promise. The two configurations are discussed in the following subsections.

#### Expanding Tube Configuration

The first configuration utilizes an expanding tube principle whereby an inner tube is expanded or stretched radially inside another tube by forcing a tapered plug into the inner tube. A soft material, such as gold, is compressed between the two tubes and the leak is formed at the interface of the gold ring and the outer tube (see Figure 2). The gold ring is brazed to the inner tube. Gold was selected to minimize the force required to deform the material. This leak configuration is a displacement-oriented device as opposed to a force- and stress-oriented device.

By selecting a fine thread on the adjustment screws and by using a very gradual taper on the plug, a very fine adjustment can be obtained. For example, if 32 threads per inch are used on the adjustment screws and a taper of 0.002 inch per inch on the plug diameter, the leak opening would be changed at a rate of:

$$0.001 \frac{\text{inch}}{\text{turn}} \times 1/32 \frac{\text{inch}}{\text{inch}} = 31.25 \times 10^{-6} \frac{\text{inch}}{\text{turn}}$$

This is a very significant improvement over the ball leak design, where the differential adjustment screw advanced at a rate of:

$$1700 \times 10^{-6} \frac{\text{inch}}{\text{turn}}$$

The ratio of the closure rate of this new design to that of the ball leak is:

$$\frac{31.25 \times 10^{-6}}{1700 \times 10^{-6}} = 0.0184 \text{ or } \frac{1}{54.2}$$

By using a fine thread, it would be possible to achieve an even finer adjustment.

With the ball leak design, the ball was not attached to any supporting member. The ball was only supported by pressing it against a sharp edge. This meant that small changes in load applied to the seat edge by the ball, due to vibration or shock, caused large changes in the stress level and consequently large changes in the deformation of the seat edge and the conductance of the ball leak.

The new configuration, shown in Figure 2, has no loose parts; and any loads caused by vibration or shock would be carried on relatively large areas. One of the advantages of this new design is that it is basically a displacement-oriented, rather than force-oriented device. This should make it inherently more stable when subjected to vibration or shock.

The effect of a temperature change on the new configuration shown in Figure 2 can be evaluated only after some dimensions have been assigned to the key elements of the assembly and materials have been selected. Since a temperature change that has no effect on the leak opening size is desirable, the dimensions and materials will be selected in such a way as to minimize the effect of a temperature change. The gold ring must be thick enough to allow for a reasonable amount of deformation without

excessive work hardening. An arbitrary thickness of 0.020 inch was selected as being reasonable. If the change in the gold ring wall thickness to the change in the difference of the tube radii is equated, then:

$$(R_1 - R_2) \alpha_3 (\Delta T) = R_1 \alpha_1 (\Delta T) - R_2 \alpha_2 (\Delta T)$$

where

$R_1$  = the outer tube inside radius

$R_2$  = the inner tube outside radius

$\alpha_1$  = the coefficient of thermal expansion of the outer tube

$\alpha_2$  = the coefficient of thermal expansion of the inner tube

$\alpha_3$  = the coefficient of thermal expansion of the gold ring

$$\text{But, } R_2 = (R_1 - 0.020)$$

and therefore,  $0.020 \alpha_3 = R_1 \alpha_1 - \alpha_2 R_1 + 0.020 \alpha_2$

$$\text{or, } R_1 = \frac{1}{50} \frac{(\alpha_3 - \alpha_2)}{(\alpha_1 - \alpha_2)}$$

If 316 stainless steel is used for the inner tube and 310 stainless steel for the outer tube, then:

$$\alpha_1 = 8.8 \times 10^{-6} \text{ in/in } ^\circ\text{F}$$

$$\alpha_2 = 8.9 \times 10^{-6} \text{ in/inch } ^\circ\text{F}$$

$$\alpha_3 = 7.9 \times 10^{-6} \text{ inch/inch } ^\circ\text{F}$$

$$\text{and } R_1 = \frac{1}{50} \frac{(7.9 - 8.9)}{(8.8 - 8.9)} = \frac{1}{50} \frac{(-1)}{(-0.1)}$$

$$\text{or, } R_1 = 0.20 \text{ inches}$$

$$\text{therefore: } R_2 = 0.20 - 0.020 = 0.180 \text{ inches.}$$

With these materials and dimensions, there would, theoretically, be no change in the leak opening size when the leak experienced a change in temperature. It seems unlikely that this degree of stability would be seen in actual practice, since the variation in the coefficient of thermal expansion of most materials is often greater than two percent. Also, there would have to be some tolerance on the dimensions of the parts that could effect the stability. However, these materials combined with these dimensions should give the best results possible.

It is desirable to keep the stress level in the inner tube below the yield strength. The stress in the inner tube is given by the expression:

$$\sigma = \frac{PR}{t}$$

where

P = the pressure exerted on the ID of the inner tube by the tapered plug lbf/in<sup>2</sup> (psi)

R = the radius of the inter tube inches

t = the wall thickness of the inter tube inches

The expression for the uniform radial pressure P on a circumferential band of width 2b is given by:

$$P = \frac{(\Delta R) Et}{R^2 (1 - e^{-b\lambda} \cos b\lambda)}$$

where

$\Delta R$  = Radial displacement (for our design 0.00018 inch)

R = MEAN radius of tube (0.1725 inch)

t = Tube wall thickness (0.015 inch)

E = Material modules of elasticity ( $29 \times 10^6$  lbf/in<sup>2</sup>)

$$\lambda = \sqrt[4]{\frac{3(1-\nu^2)}{R^2 t^2}}$$

$\nu$  = Poisson's ratio = 0.3 for 316 CRES

For this particular case,  $\lambda = 25.2$  rad/inch

and  $P = 2,540$  lbf/in<sup>2</sup> (psi)

Then,

$$\sigma = \frac{(2,540)(0.1725)}{0.015} = \frac{29,300 \text{ lbf/in}^2 \text{ (psi)}}{\phantom{0.015}}$$

which is below the published 30,000 lbf/in<sup>2</sup> (psi yield strength of annealed 316 stainless steel).

### Piston Drive Leak Configuration

The second configuration shown in Figure 3 utilizes a piston slider that is forced against a gold ring. A thin stainless steel diaphragm separates the leak chamber from the adjustment mechanism and the leak is formed at the interface of the gold ring and the stainless steel diaphragm. The gold ring is brazed to the leak housing, however, this arrangement could be reversed, with the gold ring brazed to the diaphragm and the leak formed at the interface of the leak housing and the gold ring, if this proved desirable to facilitate replacement of the gold ring.

The advancement of the piston toward the gold ring is not a linear function of the advancement of the adjustment screws, but, is a sine function of the Angle  $\theta$  formed between the axis of the piston and the axis of the link that connects the piston to the adjustment pin. That is,

$\frac{dx}{d\theta} = -R \sin \theta$ , where  $R$  is the distance between the holes in the connecting link.

This means that as the Angle  $\theta$  approaches zero, the adjustment becomes finer. That is, the amount of advancement of the piston, for an incremental advancement of the adjustment screw, becomes smaller. The last twenty-two degrees of adjustment screw rotation will advance the piston only  $1 \times 10^{-6}$  inch, whereas, the last full turn of the adjustment screw will advance the piston a total of  $1,329 \times 10^{-6}$  inches. These figures are based on an adjustment screw with twenty-eight threads per inch. Finer adjustment could be obtained using a finer thread, if this should prove desirable.

Any loads caused by vibration or shock in this design will be carried by relatively large surface areas. This means that the stresses and consequent deformations should be small compared to those experienced with

the ball leak. The use of a soft material, such as gold, makes this a displacement-oriented device with relatively low loading levels. For this reason it should be more stable than the ball leak, which was a force-oriented device, when subjected to vibration or shock.

By selecting the materials and dimensions in the same way as the first configuration, it is possible to achieve a leak with a thermal coefficient that is theoretically equal to zero. Here, the expression becomes:

$$X_2 \alpha_2 + X_3 \alpha_3 = (X_2 + X_3) \alpha_1$$

where,

$X_2$  = the distance from the gold ring to the hole in the piston

$X_3$  = the thickness of the gold ring

$\alpha_2$  = the coefficient of thermal expansion of the piston material and the piston housing material

$\alpha_1$  = the coefficient of thermal expansion of the leak housing material

$\alpha_3$  = the coefficient of thermal expansion for the gold ring.

and,

$$X_2 = X_3 \frac{(\alpha_1 - \alpha_3)}{(\alpha_2 - \alpha_1)}$$

If 316 stainless steel is used for the piston and the piston housing, and 310 stainless steel for the leak housing, and a 0.022 thick gold ring,

then,  $\alpha_1 = 8.8 \times 10^{-6}$

$$\alpha_2 = 8.9 \times 10^{-6}$$

$$\alpha_3 = 7.9 \times 10^{-6}$$

and, solving for the desired dimension, which will theoretically make the thermal coefficient equal to zero, we obtain:

$$X_2 = (0.022) \frac{(8.8 - 7.9)}{(8.9 - 8.8)}$$

$$X_2 = 0.198 \text{ inches}$$

The actual thermal coefficient would again depend upon how close the actual thermal coefficients of thermal expansion were to the published values and how close the parts dimensions were to the chosen dimensions. However, this is again the best combination that can be derived using an analytical approach.

Since no conductance equation seemed to be available for the configuration used in this second design, it was necessary to derive an appropriate equation. A general expression for conductance, regardless of configuration, is given by<sup>1</sup>:

$$C = (4/3) V_a \int_0^{\ell} \frac{H}{A^2} d\ell$$

where,

C = The leak conductance in cc/sec

H = the leak perimeter in cm

A = the leak opening area in cm<sup>2</sup>

$\ell$  = The leak length in cm

$V_a$  = the mean free velocity of the gas in cm/sec.

In this particular design there is an annular ring, with an outer radius  $R_1$ , and an inner radius  $R_2$ , spaced a distance "d" from a flat surface.

therefore,

$$A = 2 \pi R d$$

$$H = 2 (2 \pi R + d)$$

$$\ell = R_2 - R_1$$

$$d\ell = dR$$

$$C = \frac{4}{3} V_a \int_{R_1}^{R_2} \frac{4 \pi R + 2d}{(2 \pi R d)^2} dR$$

---

<sup>1</sup>Scientific Foundations of Vacuum Technique by Saul Dushman John Wiley & Sons Publisher

$$\begin{aligned}
C &= \left(\frac{4}{3}\right) V_a / \left[ \int_{R_1}^{R_2} \frac{4 \pi R}{4 \pi^2 R^2 d^2} + \int_{R_1}^{R_2} \frac{2d}{4 \pi^2 R^2 d^2} \right] \\
&= \left(\frac{4}{3}\right) V_a / \left[ \frac{1}{\pi d^2} \int_{R_1}^{R_2} \frac{1}{R} dR + \frac{1}{2 \pi^2 d} \int_{R_1}^{R_2} \frac{1}{R^2} dR \right] \\
&= \left(\frac{4}{3}\right) V_a / \left[ \frac{1}{\pi d^2} \log_e \left( \frac{R_2}{R_1} \right) + \frac{1}{2 \pi^2 d} \left( \frac{1}{R_1} - \frac{1}{R_2} \right) \right] \\
C &= \left(\frac{4}{3}\right) V_a / \left[ \frac{1}{\pi d^2} \log_e \left( \frac{R_2}{R_1} \right) + \frac{1}{2 \pi^2 d} \left( \frac{R_2 - R_1}{R_1 R_2} \right) \right]
\end{aligned}$$

If  $2d \ll 4 \pi R$ , the second term of the integral is negligible and the conductance equation reduces to,

$$C = \left(\frac{4}{3}\right) V_a / \frac{1}{\pi d^2} \log_e \left( \frac{R_2}{R_1} \right)$$

or,

$$C = \left(\frac{4}{3}\right) \pi d^2 V_a / \log_e \left( \frac{R_2}{R_1} \right)$$

Since the integration was from the outside radius toward the inside radius, negative values will be obtained upon substitution into the conductance equation. The negative sign indicates the direction of flow. If the integration were made from the inside radius toward the outside radius, positive values of equal magnitude would be obtained upon substitution into the resulting equation.



The resultant equation for integration in the opposite direction is,

$$C = \left(\frac{4}{3}\right) V_a \left/ \left[ \frac{1}{\pi d^2} \log_e \left( \frac{R_1}{R_2} \right) + \frac{1}{2 \pi^2 d} \left( \frac{R_1 - R_2}{R_1 R_2} \right) \right] \right.$$

or, if  $2d \lll 4 \pi R$ ,

$$C = \left(\frac{4}{3}\right) \pi d^2 V_a \log_e \left( \frac{R_1}{R_2} \right)$$

The expression for  $V_a$  is given by,

$$V_a = \left( \frac{8 R_o T}{\pi M} \right)^{\frac{1}{2}}$$

where,

$R_o$  = gas constant, Ergs/ $^{\circ}$ K-gr-mole

$T$  = the absolute temperature of the gas,  $^{\circ}$ K

$M$  = the molecular weight of the gas, gr/mole

For air,

$M = 28.98$  gr/mole

$R_o = 8.3146 \times 10^7$  Ergs/ $^{\circ}$ K-gr-mole

and at  $25^{\circ}$ C ( $298^{\circ}$ K):  $V_a = \frac{(8)(8.3146)(10^7)(298)}{\pi (28.98)} = \underline{\underline{4.668 \times 10^4 \text{ cm/sec}}}$

To determine the spacing between the annular ring and the flat surface for a given conductance, the conductance equation is solved for  $d$  and the following expression is obtained,

$$d = \sqrt{\frac{3C \log_e \left( \frac{R_1}{R_2} \right)}{4 V_a \pi}}$$

The equation that relates the leak conductance to the gas flow rate for molecular flow is:

$$Q = C (\Delta P)$$

where,

$Q$  = gas flow rate, torr cc/sec

$\Delta P$  = the pressure differential across the leak

$C$  = the leak conductance

If the following flow rate is chosen:

$$Q = 5.0 \times 10^{-3} \text{ torr cc/sec}$$

and if it is assumed that  $\Delta P$  will be from 50 to 1000 torr, then the leak conductance will be between

$$C_{\text{max}} = \frac{5 \times 10^{-3} \text{ torr cc/sec}}{50 \text{ torr}} = 1 \times 10^{-4} \text{ cc/sec.}$$

$$\text{then: } C_{\text{MIN}} = \frac{5 \times 10^{-3} \text{ torr cc/sec}}{1000 \text{ torr}} = 5 \times 10^{-6} \text{ cc/sec.}$$

For these two extremes in conductance the maximum and minimum values for  $d$  can be calculated, if,

$$R_1 = 0.025 \text{ inch} = 0.0635 \text{ cm}$$

$$\text{and, } R_2 = 0.015 \text{ inch} = 0.0381 \text{ cm}$$

Then:

$$d_{\text{min}} = \sqrt{\frac{(3)(5 \times 10^{-6}) \log_e \left( \frac{0.0635}{0.0381} \right)}{(4)(4.668 \times 10^4) \pi}}$$

$$d_{\text{min}} = 3.61 \times 10^{-6} \text{ cm} = 1.42 \times 10^{-6} \text{ inch at 1000 torr}$$

and

$$d_{\max} = \sqrt{\frac{(3)(1 \times 10^{-4}) \log_e \left( \frac{0.0635}{0.0381} \right)}{(4)(4.668 \times 10^4) \pi}}$$

$$d_{\max} = 16.15 \times 10^{-6} \text{ cm} = 6.36 \times 10^{-6} \text{ inch at 50 torr}$$

Therefore, the gap between the gold ring and the diaphragm will be approximately  $1 \times 10^{-6}$  to  $16 \times 10^{-6}$  inch, depending on the operating pressure differential and the exact value of conductance that is required to give the desired flow. As a check, it should be noted that  $d_{\max} \approx 0.16$  micron, which satisfies the requirements for molecular flow as discussed in the Summary. Comparing the range of gaps required with the capabilities of the drive mechanism, it appears that the required degree of adjustment can be obtained.

#### SINTERED LEAK DEVELOPMENT

Because of the difficulties experienced with the adjustable ball leak, a continuing effort has been undertaken at Perkin-Elmer to establish other possible leak concepts. Communication with NASA Goddard Spaceflight Center indicated that GSFC had been working with a leak material for use with a flyable mass spectrometer for sampling the Martian atmosphere at about ten torr. GSFC's approach was, in turn, based upon some work carried on for the U.S. Air Force.\* GSFC was working with a sintered material supplied by CUNO Corporation, which they then compressed and welded onto the end of a tube to form a leak assembly. Perkin-Elmer obtained some of the compressed material from GSFC with which to perform some preliminary tests. GSFC indicated that the application of this type of leak could possibly be extended to the one atmosphere pressure range.

The present effort was directed toward the full evaluation of the sintered metal leak. This involved establishing a suitable vendor for material and a suitable manufacturing technique. Leaks were then evaluated through extensive tests to determine such characteristics as flow linearity with pressure conductance values, conductance temperature coefficient and susceptibility to plugging from water vapor and/or contamination. The results of these tests indicated that the sintered leak meets all of the

---

\*"Evaluation of Porous Materials as Molecular Leaks", A.J. Mathews, July 1964, ARO Project No. SW2411

requirements for a mass spectrometer inlet leak, with the possible exception of time response. On the whole, however, the sintered leak represents a significant step forward in direct entry inlet systems for mass spectrometry and it is believed that with further effort the leak can be made acceptable for rapid rate measurements.

#### Fabrication of Sintered Leaks

The sintered leaks were made by Mott Metallurgical Corporation, Farmington, Connecticut by starting with 325 to 400 mesh stainless powder. The powder is compressed in a die under 140,000 pounds per square inch (lbf/in<sup>2</sup>) pressure. This decreases the volume to about forty percent of the original and increases the density to nearly ninety percent of metallic stainless. The pellet thus formed is then sintered at 2,200 degrees Fahrenheit. After the initial sintering of the pellet alone, it is sintered into a leak holder. The leak is then checked for conductance and conductance is then adjusted downward by alternately sintering and pressing until the desired value is reached. The Mott Corporation measures conductance at 1,500 pounds per square inch in units of standard cubic centimeters per minute using a bubblometer. The leak used for the extended tests described here was delivered to Perkin-Elmer with a rated conductance of 0.37 standard cubic centimeter per minute at 1,500 pounds per square inch. The conductance expressed in the units used in our laboratory is  $6.2 \times 10^{-5}$  cubic centimeters per second. This value is ten times larger than the value measured by our laboratory at pressures of one atmosphere and below. The reason for the discrepancy lies in the fact that the conductance is not in the molecular flow regime at the high pressure used by Mott. As described earlier, the requirement for molecular flow can be translated into a maximum diameter of a flow channel of about 0.2 micron. Using a slightly smaller diameter, the conductance of a 0.15 micron diameter channel at 1,500 pounds per square inch can be calculated with the Knudsen flow equation. The result is a conductance twelve and eight-tenths times the molecular conductance. This is approximately what is observed. A slightly smaller diameter would give the exact ratio.

Since molecular flow results in many more wall collisions than molecular collisions, each constituent of the sample gas flows independently. As a result, the measurement of one component is not affected by the presence of other components, and there is a linear relationship between the pressure in the ion source and the pressure in the sample environment. Molecular flow is thus required in order to make a reasonable quantitative interpretation of mass spectrometer measurements.

The leak delivered by Mott was next welded into the valve body shown in Figure 4. The valve body was mounted to the test setup shown in Figure 5, for the procedures described below.

#### Test Procedures

The leak was mounted with the filters and inlet system as shown in Figure 5. The conductance,  $C_0$ , of the sintered leak in this setup is given by the relation:

$$C_0 = \frac{P_1 - P_2}{P_0} \cdot C_1 \text{ cc/sec} \quad (1)$$

where,  $P_1 - P_2$  is the pressure drop across the known leak  $C_1$ .

$C_1$  is an aperture whose molecular conductance is  $120 \sqrt{T} \text{ cc sec}^{-1}$ .

Since  $P_0 - P_1 \approx P_0$ ,  $P_0$  is the pressure drop across the leak  $C_0$ . The pressure  $P_1$  and  $P_2$  are measured with ion gauges, taking care to correct these values for the background pressure of the system.  $P_0$  was measured with the inlet system manometer when the flow was stopped. Six or more values of  $P_0$ , varying between ten torr and 800 torr are used for each measurement of  $C_0$ .

A typical set of conductance measurements at various inlet pressures is shown in Figure 6. The deviation evident at very low pressures is frequently observed, because the system background pressures are on the same order of magnitude as the pressures due to the sample flow. When this is observed, the low pressure values are discarded in computing the average. Viscous flow is indicated by rising conductance values at higher inlet pressures.

To study the temperature coefficient of conductance, the system was wrapped in heating tapes in the vicinity of the  $C_1$  and  $C_0$ . The temperature of the leaks were monitored with thermocouples. At each ten degree interval from 50 to 100 degrees centigrade a set of conductance measurements was made. Three cycles up and down in temperature were completed and a total of eighty conductance measurements were completed over a span of twenty days.

The time response of the filters and leak assembly was examined by rapidly changing the flow rate and inlet pressure with the solenoid valve. Flow and pressure varied from forty six cubic centimeters per minute with  $P_0$  at 760 torr to 201 cubic centimeters per minute with  $P_0$  at 174 torr. Gauge  $P_1$  was used to measure the rate of pressure rise and hence the leak time response. The gauge output drove the vertical amplifier of an oscilloscope. The time base of the oscilloscope was on single sweep mode triggered by the same solenoid that changed the pressure and flow. The resulting pressure-time plots were photographed at the oscilloscope screen.

To ensure that the gauge control circuit was not limiting the time response, tests were made using a fast responding electrometer as the sensitive element. The time response of the leak only was examined with the inlet system disconnected. In this case, the pressure was changed by hand by holding a rubber stopper over the leak housing and rapidly drawing it away as the oscilloscope was triggered. Several additional alternate arrangements of the test system were also tested to find their effect on the time response. Tests were first made comparing open and closed positions of the bypass valve. Next, the fittings were rearranged so that the flow from the leak was directed on the collector of the ion gauge. And finally, the time responses of nitrogen, air and argon were compared.

#### Temperature Response

The results of conductance measurements made during three temperature cycles between 50 and 100 degrees centigrade and back are shown in Figure 7. The data on a typical run showed a scatter approximately the same as that observed on the long term test. If all six measurements for each temperature were averaged, the conductance shows a trend (curve A) that is not inconsistent with a  $\sqrt{T}$  dependence (curve B).

A model of the sintered leak for the purpose of making comparison calculations could take the form of a number,  $N$ ; of long circular pipes. The equation for molecular conductance in such a model is:

$$C = \frac{N}{6} \sqrt{\frac{2 \pi kT}{m}} \frac{d^3}{l} \quad (2)$$

$C$  = conductance, cc sec<sup>-1</sup>

$k$  = Boltzmann constant

$m$  = molecular weight

T = absolute temperature (°K)

d = channel diameter (cm)

ℓ = channel length

N = number of channels

This relation is reduced from the general Knudsen equation for very low pressure.

The  $\sqrt{T}$  temperature dependence arises from the temperature dependence of the molecular velocity. For the same reason, the aperture leak  $C_1$  has the  $\sqrt{T}$  temperature dependence. Appropriate temperature corrections were made for all conductance calculations.

The effect of thermal expansion is expected to be far less than the molecular velocity effect. The coefficient of thermal expansion for the metals used lies in the range  $10^{-5}$  per degree centigrade. A temperature change of fifty degrees centigrade would therefore change dimensions of the leak channels by less than one part in a thousand.

#### Time Response

A typical time response of the filters and leak assembly is shown in Figure 8. In this curve two time constants are evident. First, the delay from triggering time until the first pressure change is recorded by the ion gauge. This delay is measured by the short horizontal portion of the trace near origin. To compare this with a calculated delay time the following relation is used:

$$\Delta t_1 = \frac{P_0 \times AL}{Q} \quad (3)$$

$\Delta t$  = delay (sec)

$P_0$  = inlet line pressure (torr)

A = area of inlet line ( $5.6 \times 10^{-2} \text{ CM}^2$ )

L = length of inlet from solenoid to leak  $C_0$  (40 cm)

Q = flow (torr cc sec<sup>-1</sup>)

For  $P_0 = 500$  torr and  $Q = 1.67$  cc sec<sup>-1</sup> at 729 torr,  $\Delta t_1 \approx 0.1$  sec.

The next time delay that can be calculated is that due to the finite drift velocity in the leak channels.

This time delay is given by the relation:

$$\Delta t_2 = \frac{p \cdot a \cdot \ell}{q} = \frac{p \cdot \pi d^2 \ell}{4q} \quad (4)$$

where  $p$  = average pressure in leak (torr) =  $\frac{P_0 - P_1}{2}$  torr

$a$  = area of single leak channel ( $\text{cm}^2$ )

$\ell$  = length of channel (cm)

$d$  = diameter of channel (cm)

$q$  = flow per channel ( $\text{torr cm}^3 \text{sec}^{-1}$ )

The conductance per channel is found from Equation (2).

$$C = \frac{q}{P_0} = \frac{q}{2p} = \frac{N}{6} \sqrt{\frac{2 \pi k t}{m}} \frac{d^3}{\ell} \quad (5)$$

where  $p_0$  is the pressure at the high pressure side. ( $P_0 \approx 2p$ )

Substituting (5) in (4) we have

$$\Delta t = \frac{10^{-3} \pi \ell^2}{96 d} \text{ sec.}$$

Equations (2) and (4) are plotted in Figure 9. It has been shown that  $d$  must be less than 0.15 microns for molecular flow at atmospheric pressure; therefore,  $d$  is restricted to this range in the figure. From this figure, it is possible to construct a model having the observed five-tenths of a second delay. For example 10,000 channels having  $d$  equals two-tenths of a micron and  $\ell$  equals six millimeters would have the observed five-tenths of a second delay observed at the threshold of Figure 8. This is not a unique model, but is given only as an example.

The second time constant apparent in Figure 8 is the overall time required for the gauge pressure to come to a new equilibrium. At time equals zero in the figure, pressure  $P_0$  is suddenly changed by 200 torr. The resultant change in flow through the leak  $P_0 C_0$ , is  $10^{-3}$  cubic centimeters per second. The volume of chamber  $P_1$  is 215 cubic centimeters. If chamber  $P_1$  were isolated, its pressure would rise due to the new flow at a rate of approximately  $5 \times 10^{-6}$  torr per second. The volume of the remaining portion



of the system up to the ion pump is about 2000 cubic centimeters. The same flow could therefore increase the pressure in the entire system at a rate of  $5 \times 10^{-7}$  torr per second. As seen in Figure 8, the steepest part of the pressure time curve is only  $1.1 \times 10^{-6}$  torr per second. The rate of pressure rise of the overall system, as observed at P<sub>2</sub>, also was slow by a factor of five; furthermore, this factor five or more discrepancy was observed at all values of flow and P<sub>0</sub> that were tested.

The alternate arrangements of the apparatus that were tested, i.e., with the leak directed at the ion gauge collector, with the bypass valve open and closed, and with argon as the test gas resulted in time constants practically identical to that shown in Figure 8.

In summary, note that the time dependent variation of the pressure, P<sub>1</sub> as it responds to a variation in the pressure at the end of the inlet line, is governed by three factors: First, the time required to fill the inlet line to the new pressure up to the leak; second, the time required to drift through the leak channels; and third, the time required to fill the volume to the new pressure, P<sub>1</sub>.

The first two delays must be summed to determine when the first effects of the new pressure are felt by P<sub>1</sub>. The inlet line delay time is approximately one-tenth of a second, leaving five-tenths of a second to be accounted for by the leak. 10,000 channels six millimeters long with approximately two-tenths of a micron diameter would cause approximately this delay. This model is not unique. Finally, the observed time required to fill the volume indicates a large apparent volume that can be explained by an assumed wall loading.

It is well known that, at  $10^{-6}$  torr, some  $10^4$  to  $10^5$  times as many gas molecules reside on the walls as in the volume of even the cleanest vacuum system. Most of these molecules are tightly bound, being continually desorbed and reabsorbed in equilibrium with the gas phase. When the ambient pressure is changed, some fraction of the absorbed molecules must take part in the change. If the number of absorbed molecules taking part in a change in pressure were equivalent to five times the volume, it would still be only a small fraction of the total absorbed molecules. Thus, an apparent volume five times larger than the actual volume exists, and the measured time response is simply the time required to fill this apparent volume (mostly wall absorption).

The conclusion of the time response measurements is that the overall time response appears to be controlled by the test system rather than the leak itself. The threshold delay cannot uniquely indicate any of the leak parameters. Additional tests, utilizing a mass spectrometer instead of the ion gauge, should give more unambiguous results, because of the small volume of the ion source.

## Long Term Stability

The leak has sampled gas at an inlet line flow rate of 150 cubic centimeters per minute, for a total of 1,710 hours, with the results shown in Figure 10. The first 59 hours were run with dry nitrogen filtered with 0.45 micron millipore filters in the line, in the positions shown in Figure 5. At t equals 91 to t equals 159 hours the nitrogen was bubbled through a washing tower. The inlet line and filters were warmed slightly during the wet nitrogen test to prevent condensation. At t equals 160 hours the millipore filters were removed, so that the inlet system sampled unfiltered laboratory atmosphere from that time on except for the period from 330 to 374 and t equals 732 to 756 hours, when the wet nitrogen tests were repeated. At t equals 374, 442, and 443 hours the leak sampled thick cigarette smoke. The cigarette was mounted on a plastic tube attached to the inlet system so that the inlet drew on the cigarette producing the smoke.

The dust level of the unfiltered laboratory air was measured by Micron-Netics Company, of Pasadena. They used the technique of pumping a sample of lab air through a clean filter and counting the collected dust particles under the microscope. Micron-Netics obtained the following results from a sample collected adjacent to the leak test station.

<u>Particle Size Range in Microns</u>	<u>Particles per Cubic Foot</u>
Less than 5	30,000 (est.)
5 to 25	214
25 to 50	12
Larger than 50	0

Converting to appropriate units for comparison, it is found that 1,710 hours at 150 cubic centimeters per minute means that a total of 567 cubic feet were pumped through the inlet line in a long-term test.

Up to the 1,410 hour point in the long-term test no trend in conductance was indicated. The variations appeared to be more of a random nature and were probably more indicative of the measurement technique. Of particular interest was the fact that smoke did not in the least affect the conductance of the leak. At t equals 1,410 hours, the wet nitrogen source was again connected to the test fixture and the heat to the inlet lines was removed. The leak itself was still five to ten degrees centigrade warmer than the wet nitrogen source, because of its proximity to the ion gauge.

The wet nitrogen flowed for 240 hours, during which time a definite increase in conductance was noted. The leak finally decreased to ten percent of its previous value when the test was running unattended over an entire weekend. After twelve hours baking at 250 degrees centigrade the leak did not unplug at all. A bake to 410 degrees centigrade increased the conductance to  $3.14 \times 10^{-6}$  cubic centimeters per second, thus, half unplugging it. At the same time, the hot bake burned a nylon gasket in the inlet line, letting air and nylon "tar" run against the leak while it was hot. With a high temperature gasket in place, the leak was baked an additional twelve hours at 400 degrees centigrade with the leak remaining at  $3.1 \times 10^{-6}$  cubic centimeters per second. At this point, the test was terminated.

In conclusion, the long-term test indicates that the leak is extremely stable in a normal room environment where no particular effort is made to lower the dust count or the relative humidity. Water saturated gas samples will plug the leak, and when they do, temperatures of 400 degrees centigrade are required to remove the water from the pores of the leak.

#### METAL MEMBRANE LEAKS WITH SUBMICRON-SIZE PORES

During the contract effort of evaluating the stability and other properties of sintered leaks, there appeared in the literature a description of a new material with apparent potential application as a molecular leak.\* Samples were obtained from Dr. Cline of General Electric Research Center, and an investigation was performed by Perkin-Elmer to learn what would be involved in adapting this material for use as a mass spectrometer leak of the desired conductance.

The potential leak material reported by Dr. Cline is porous metal wafers produced by selectively etching the rod phase of directionally solidified eutectics nickle, aluminum-chromium and nickel, aluminum-molybdenum.

The ingots are prepared from 33 nickel, 33 aluminum, 34 chromium, and 45.5 nickel, 45.5 aluminum, 9 molybdenum (given in atomic percent). These ingots are remelted and directionally solidified. In the chromium alloy the chromium rods occupy thirty four percent of the composite, whereas the molybdenum rods occupy only nine percent of the other material by volume. Whether there are many small closely-spaced rods, or fewer larger rods depends on the rate of the directional cooling process. In the paper referred to, Desorbo and Cline show rods of five tenths of a micron diameter and larger. The smallest rods, however, are associated with a cell structure

---

\*W. Desorbo and H.E. Cline "Metal Membranes With Uniform Submicron-Size Pores", Journal of Applied Physics 41, 2099 (1970).

of much larger rods. It is indicated that pure materials, low cooling velocities and high temperature gradients might give a uniform structure of one-tenth of a micron diameter pores.

The rods are selectively removed from the nickel, aluminum matrix by etching in an electrolytic cell at five volts in an aqueous solution of three percent oxalic acid. The thickness normally used at General Electric ranged from twenty to fifty microns; Perkin-Elmer was assured that the selective etching would work even at thicknesses ten times greater. It appears possible to produce arrays of submicron holes in this material with length/diameter ratios of 500 or more.

To summarize; the length of the holes in the nickel, aluminum membrane can be easily varied over a wide range and the diameter has been adjusted down to five-tenths of a micron and could probably be made smaller with some effort. It remains only to choose the number of holes, and to fasten the membrane to a rugged holder for installation in the mass spectrometer. An ideal leak would use a membrane as thin as possible, in keeping with structural soundness. This insures fast time response. In addition, the pore size must be two-tenths of a micron diameter or smaller to insure molecular flow at atmospheric pressure. With these two parameters fixed, a calculation of the molecular flow rate per channel will dictate the number of channels required for the desired conductance.

Two samples of the nickel, aluminum-chromium wafers were obtained by Perkin-Elmer from General Electric to investigate the problem of choosing the number of holes and fastening the membrane in a test fixture. One sample was fifty microns thick, with the holes already etched. The second piece was the same thickness with the chromium rods still in place. The rods (or holes) were eight-tenths of a micron diameter on one and one-half micron centers. The molecular conductance per hole is calculated to be approximately  $10^{-6}$  cubic centimeters per second. A desirable conductance for a mass spectrometer sampling atmosphere is  $10^{-5}$  cubic centimeters per second.

The technique used to attempt plugging the holes, or masking the membrane in advance of the etching step, utilized photoresist. Shipley AZ-1350 is a positive working photoresist used extensively in microelectronics fabrication. It has resolution capabilities greater than five-tenths of a micron. The resist was applied following the standard procedures used in the fabrication of microminiature semiconductor devices on silicon wafers. The process steps consist of spinning the resist on the sample to a thickness of about one micron, drying, exposing a ten micron diameter spot with ultraviolet light (using a ten micron Siemens aperture as a mask), developing, and rinsing in distilled water. The development rinses away the exposed ten micron spot, leaving the remainder of the membrane covered with photoresist. Nine or ten holes could be seen through the hole in the resist.

With only two samples to work with, all practice runs were done on silicon wafers, until spinning times, exposure times, development, and mask handling were established. Unfortunately, in spite of these precautions, the attempts at isolating ten holes were not successful. The sample with previously etched holes appeared in good condition when examined under a microscope, but conductance measurements showed that the photoresist failed to adequately plug the other holes. Its conductance was 100 times too high. Similarly, the unetched sample appeared very good, with a nicely positioned hole through the resist. When placed in the etch solution, however, the photoresist peeled away in many spots allowing the etch to attack over too large an area. Attempts to clean the surface and reprocess with photoresist resulted in progressively worse surfaces. Adhesion was inadequate.

A review of the literature of resist techniques indicates that these alloys are particularly difficult to work with. Without special processing, the surface is passive and the resist is loosely bonded. Special ingredients for these problem materials do exist, and with a larger supply of material, successful photo etch techniques could certainly be found.

In conclusion, the metal membranes described by Desorbo and Cline do show great promise as ideal, thin, molecular leaks with fast time response. Further experimental effort is indicated in order to grow ingots with two-tenths of a micron or smaller rods, and further photoresist work is needed to establish a technique for choosing a desired number of holes. The problem of fastening the wafers to a more easily handled holder also needs to be solved.

#### CONCLUSIONS

The long-term test indicates that the sintered leak is extremely stable in a normal room environment where no particular effort is made to lower the dust count or the relative humidity. Water saturated gas samples will plug the leak slowly, and when they do, baking to 400 degrees centigrade is required to remove the water from the pores of the leak. The sintered leaks exhibit a temperature coefficient of only two-tenths of a percent per degree centigrade. Fast time responses were not indicated by the measurements presented here, but with further effort the leak could possibly be made acceptable for rapid rate measurements.

The design analysis of two adjustable mechanical molecular leaks indicates excellent stability and adjustability as compared with the previously tested adjustable ball leak. However, the adjustable leak still appears less stable than the molecular leak. In addition, the sintered leak lends itself more readily to the geometries required in a fast responding inlet leak assembly. In view of these comparisons and because of the very promising results on the sintered leaks, it is recommended that future effort be directed toward improving the sintered leaks and optimizing their geometry for a fast responding system.

## APPENDIX A

## DESIGN ANALYSIS OF BALL LEAK

## Introduction

The 340838 Ball Leak Assembly has several problems associated with it, such as temperature and vibrational instability and poor setability. The leak is formed by pushing a sharp knife edge against a ball that has tiny grooves or scratches on its surface.

## ANALYSIS

This analysis will compare the experience gained in testing the ball leak with theoretical predictions in the areas of setability, temperature stability and vibrational stability.

Setability.- Theoretically, the grooves in the ball have a depth less than or equal to 5.12 microinches. This means that very small changes in the dimensions or positions of parts are likely to have a large effect on the leak conductance. Examination of the leak seat and ball under 300 to 1 magnification showed that the seat knife edge and the ball surface have relatively large pits in them so that the amount of deformation required to shut off the leak is much more than 5.12 microinches. Some of the pits are as large as 130 microinches wide. If it is assumed that the pits are almost half as deep as they are wide, then it could take as much as 100 microinches or 0.0001 inch of movement after the ball makes contact with the seat to shut off the leak (assuming that a pit in the ball was in alignment with a pit in the seat). It is important to remember that a sharp edge is being loaded and that this will cause a very large stress concentration at the edge of the seat and on the ball.

Due to this stress concentration, the strain is not uniformly distributed throughout the seat and ball, but is concentrated at the ring where the seat edge contacts the ball. If it is assumed that all but an insignificant amount of the deformation takes place within 0.005 inch of the seat edge, and that the ball and seat are deformed equally, then the strain would be

$$\epsilon = \frac{0.0001 \text{ in}}{0.010 \text{ in}} = 0.010 \text{ inch/inch}$$

This would be enough strain to exceed the elastic limit of the material. The strain required to exceed the elastic limit is approximately 0.0095 inch/inch.

The leak test results showed that rotation of the adjustment screw had little or no effect at first. Then, the leak conductance approached the desired level rapidly.

Once the desired conductance was reached, approximately one more degree of rotation completely shut off the leak. Until the leak openings are reduced in size to approximately five microinches, there will be little change in conductance. Molecular flow conditions would not exist until the openings are reduced to this size.

The amount of rotation of the adjustment screw required to advance the loading screw 0.0001 inch is 209 degrees. The amount of rotation required to move the screw through the last 5.12 microinches is 1.07 degrees. This is excellent agreement between the test results and what can be predicted after examining the ball and seat under high magnification.

Temperature Effect.- When considering the effect of temperature variation it must be remembered that the leak has been adjusted to the desired level of conductance before it is subjected to the change in temperature. This means that the openings in the leak have already been reduced to 5.12 microinches or less.

All of the leak assembly parts have the same coefficient of thermal expansion except for the gold gaskets, the ball and the seat. Since the yield strength of gold is negligible, any increase in loading on the gold gaskets due to the difference in thermal expansion of the materials will result in additional strain or cold flowing of the gold gaskets and will not change the pressure on the seat and ball. The ball and seat are made of the same material and therefore have the same coefficient of thermal expansion. The difference in the coefficients of thermal expansion between the other materials and the ball and seat is  $1.0 \times 10^{-7}$  in/in $^{\circ}$ F. The length through which the difference in thermal expansion takes place is  $L = 0.182$  inch. During testing of the leak, the temperature was increased from 79.7 $^{\circ}$ F to 203 $^{\circ}$ F. This is a  $\Delta T$  of 123.3 $^{\circ}$ F. Under these conditions, the differential strain would be:

$$\Delta\epsilon = (\Delta\alpha)(\Delta T) = (1.0 \times 10^{-7} \text{ in/in}^{\circ}\text{F})(123.3^{\circ}\text{F})$$

$$\Delta\epsilon = 12.33 \times 10^{-6} \text{ in/in}$$



The change in the leak openings would be:

$$L (\Delta\epsilon) = (0.182)(12.33)(10^{-6}) = 2.25 \times 10^{-6} \text{ inches, or } 2.25 \text{ microinches.}$$

Since the initial openings were approximately 5.12 microinches, the openings would now be approximately 2.87 microinches. The leak conductance will be reduced because the leak openings are smaller. However, the increase in temperature will partially offset this reduction, since the molecular leak rate increases as the square root of the ratio of the absolute temperatures,

$$\text{i.e., } \sqrt{\frac{T}{T_1}}$$

If it is assumed that the leak openings are initially 130 microinches wide and 5.12 inches high, and that these openings are reduced in size to 2.87 inches high by 130 inches wide, and that the length of these openings is ten microinches, then the ratio of the conductance at the elevated temperature to the conductance at the initial temperature is given by the expression,

$$\frac{C_2}{C_1} = \left( \frac{t_2}{t_1} \right)^2 \left[ \frac{L^{-1} t_1 + (w + t_1) (2.65 w K_1)^{-1}}{L^{-1} t_2 + (w + t_2) (2.65 w K_2)^{-1}} \right] \sqrt{\frac{T}{T_1}}$$

- where:
- $C_2$  = the conductance at the elevated temperature
  - $C_1$  = the conductance at the initial temperature
  - $t_2$  = leak opening height at the elevated temperature
  - $t_1$  = leak opening height at the initial temperature
  - $L$  = the length of the leak openings
  - $w$  = the width of the leak openings
  - $T$  = the elevated temperature
  - $T_1$  = the initial temperature
  - $K_1$  and  $K_2$  = constants obtained from curve of  $K$  vs.  $t/w$ .  
(See Figure 11.)

In this case,

$$t_2 = 2.87 \text{ microinches}$$

$$t_1 = 5.12 \text{ microinches}$$

$$L = 10.0 \text{ microinches}$$

$$w = 130 \text{ microinches}$$

$$T = 95^\circ\text{C} = 203^\circ\text{F} = 368^\circ\text{K}$$

$$T_1 = 26.5^\circ\text{C} = 79.7^\circ\text{F} = 299^\circ\text{K}$$

$$K_1 = 1.66$$

$$K_2 = 1.80$$

and,

$$\frac{c_2}{c_1} = \left( \frac{2.87}{5.12} \right)^2 \left\{ \frac{\left( \frac{5.12}{10} \right) + (130+5.12) [(2.65)(1.30)(1.55)]^{-1}}{\left( \frac{2.87}{10} \right) + (130+2.87) [(2.65)(130)(1.8)]^{-1}} \right\} \sqrt{\frac{368}{299}}$$

$$\frac{c_2}{c_1} = (0.561)^2 \left[ \frac{(0.512) + (135.12)(572)^{-1}}{(0.287) + (132.87)(620)^{-1}} \right] \sqrt{1.23}$$

$$\frac{c_2}{c_1} = (0.315) \left[ \frac{0.512 + 0.236}{0.287 + 0.214} \right] 1.11$$

$$\frac{c_2}{c_1} = (0.315) \left( \frac{0.748}{0.501} \right) (1.11)$$

$$\frac{c_2}{c_1} = (0.315)(1.49)(1.11) = 0.521$$

or,

$$c_2 = 0.521 c_1$$

Theoretically then,  $C_2$  would be 52.1 percent of  $C_1$ . The test results showed that  $C_2$  was actually 51.6 percent of  $C_1$ . This is very close to the calculated percentage change. The test results also showed that the conductance did not return to the original value when the temperature was lowered. This could be due to stressing the material past the yield point. It was shown in this analysis that the seat and ball are likely to be operating very close to their yield point. If the assumed value for  $L$  in the foregoing calculation were off by a factor of ten, this would only change the conductance ratio by approximately ten percent.

Vibrational Effect.- The ball leak assembly was not run through a vibration test. However, it was noted that the leak conductance would change when the leak was tapped sharply with a screw driver. Since no specific test data is available, no comparison can be made between the theoretical and observed vibrational effects. Therefore, a theoretical and hypothetical case will be presented here in an attempt to provide some indication of the vibrational stability which might be expected. The ball weight is  $3.14 \times 10^{-4}$  pounds. If the leak were subjected to a 25 g acceleration along the axis of the ball and seat, the added force on the seal would be:

$$(3.14 \times 10^{-4})(25) = 7.86 \times 10^{-3} \text{ pounds.}$$

If it is assumed that the seat edge is an annular ring, ten microinches wide, then the seat area would be,

$$A = \pi/4 (D_1^2 - D_2^2) = \pi/4 [(0.05442)^2 - (0.05440)^2]$$

$$A = (0.785)(21.76 \times 10^{-7})$$

$$A = 1.70 \times 10^{-6} \text{ in}^2$$

The increase in stress would be

$$\Delta\sigma = (7.86 \times 10^{-3}) / (1.70 \times 10^{-6})$$

$$\Delta\sigma = 4630 \text{ lbf/in}^2 \text{ (psi)}$$

If the elastic limit has not been exceeded as yet, the increase in strain would be,

$$\Delta \epsilon = \frac{\Delta \sigma}{E} = 4630 / 29 \times 10^6 = 1.60 \times 10^{-4} \text{ inch/inch}$$

If it is assumed that all but an insignificant amount of the deformation takes place within 0.005 inch of the seat edge, then the change in the leak openings would be:

$$(1.60 \times 10^{-4}) (0.010) = 1.60 \times 10^{-6} \text{ inch, or 1.60 microinches.}$$

If the openings were initially 5.12 microinches high, they would now be 3.52 microinches high. If the openings are assumed to be 130 microinches wide, then the ratio of the new conductance to the original conductance is given by the expression:

$$\frac{C_2}{C_1} = \left( \frac{t_2}{t_1} \right)^2 \left[ \frac{L^{-1} t_1 + (w + t_1) (2.65 w K_1)^{-1}}{L^{-1} t_2 + (w + t_2) (2.65 w K_2)^{-1}} \right]$$

From Figure 11,  $K_1 = 1.66$  and  $K_2 = 1.76$

Therefore,

$$\frac{C_2}{C_1} = \left( \frac{3.52}{5.12} \right)^2 \left[ \frac{\frac{5.12}{10} + (130+5.12) [(2.65)(130)(1.66)]^{-1}}{\frac{3.52}{10} + (130+3.52) [(2.65)(130)(1.76)]^{-1}} \right]$$

$$\frac{C_2}{C_1} = (0.687)^2 \left[ \frac{(0.512)+(135.12)(572)^{-1}}{(0.352)+(133.52)(605)^{-1}} \right]$$

$$\frac{C_2}{C_1} = (0.472) \left[ \frac{0.512+0.236}{0.352+0.220} \right] = (0.472) \left( \frac{0.748}{0.572} \right)$$

$$\frac{C_2}{C_1} = 0.618 \quad \text{or,}$$

$$C_2 = 0.618 C_1$$

This would be a reduction of 38.2 percent.

It should be remembered that the foregoing analysis was based on the following assumptions:

- a. The leak seat area is formed by a 10 microinch wide annular ring of mean diameter 0.05441.
- b. The seat area does not change significantly with the increases in stress being dealt with.
- c. The induced stress is within the elastic limit of the ball and seat material.
- d. All but an insignificant amount of the material deformation takes place within 0.005 inch of the seat edge.
- e. The leak openings have a rectangular cross section.
- f. The equations used are accurate in the  $10^{-6}$  inch range.

Any or all of these assumptions could be incorrect. However, most of these assumptions are conservative and will tend to make the change in conductance smaller than it might actually be.

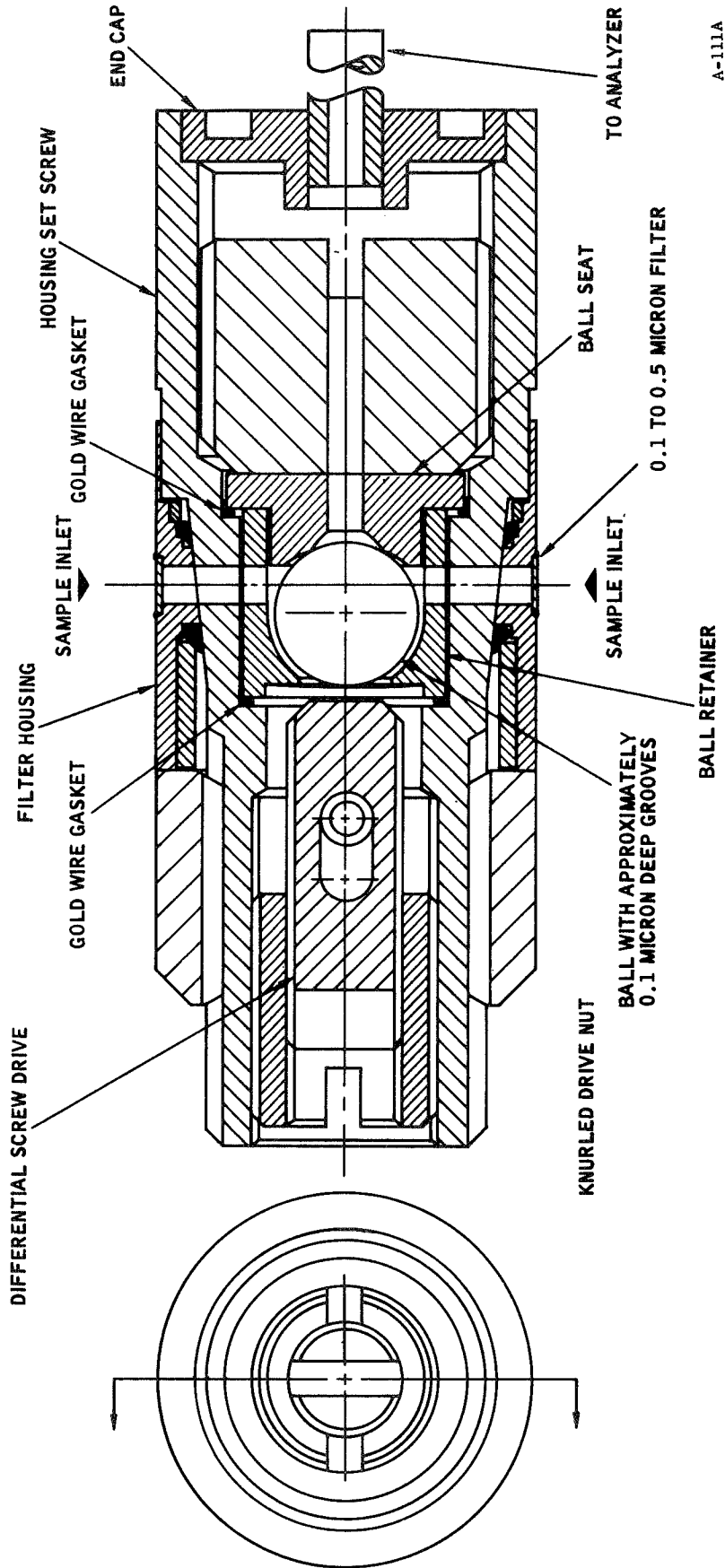

FIGURE 1.- Ball Leak Assembly Developed in NAS1-6387

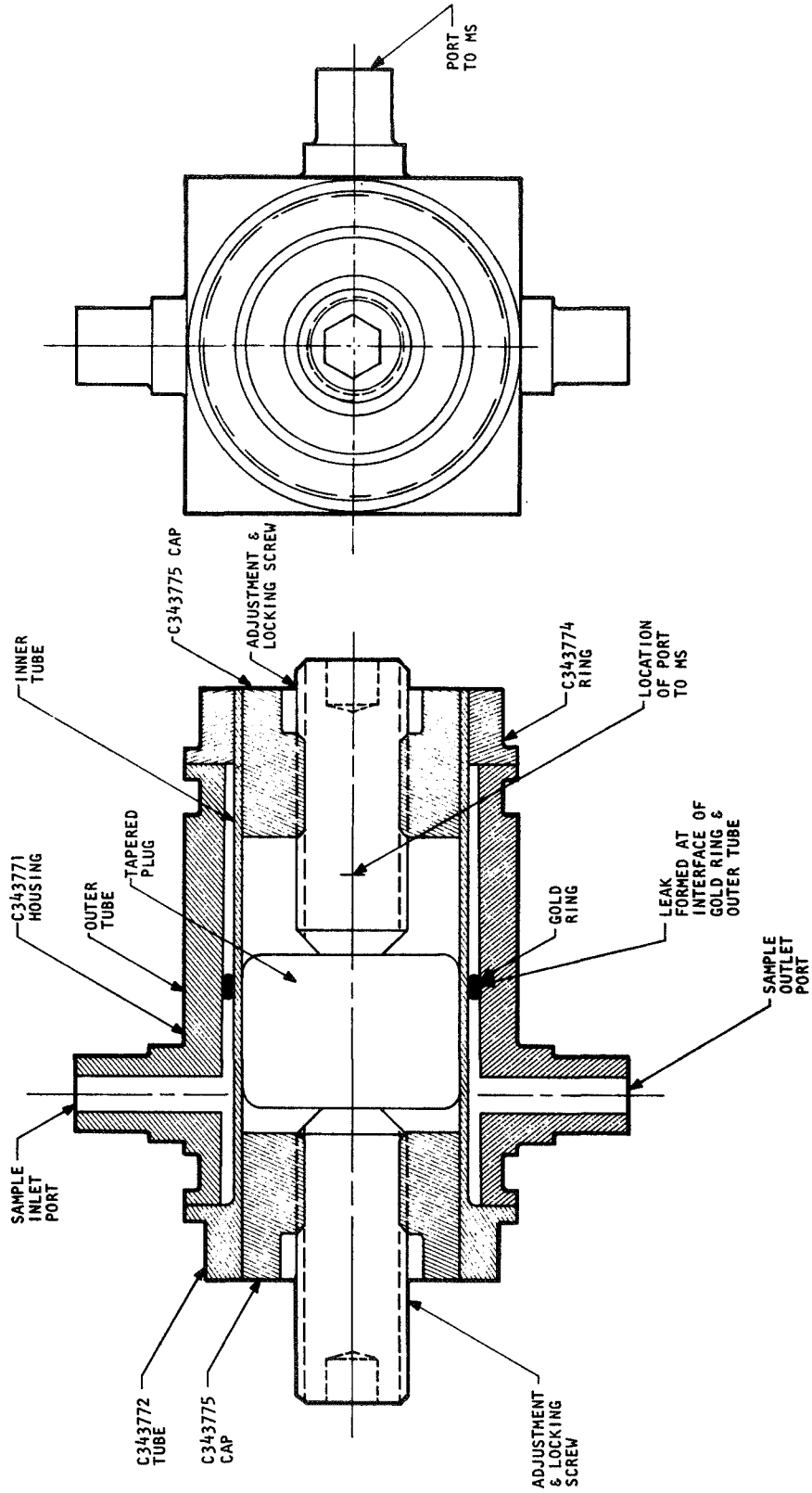

FIGURE 2.- Leak Assembly, Expanding Tube

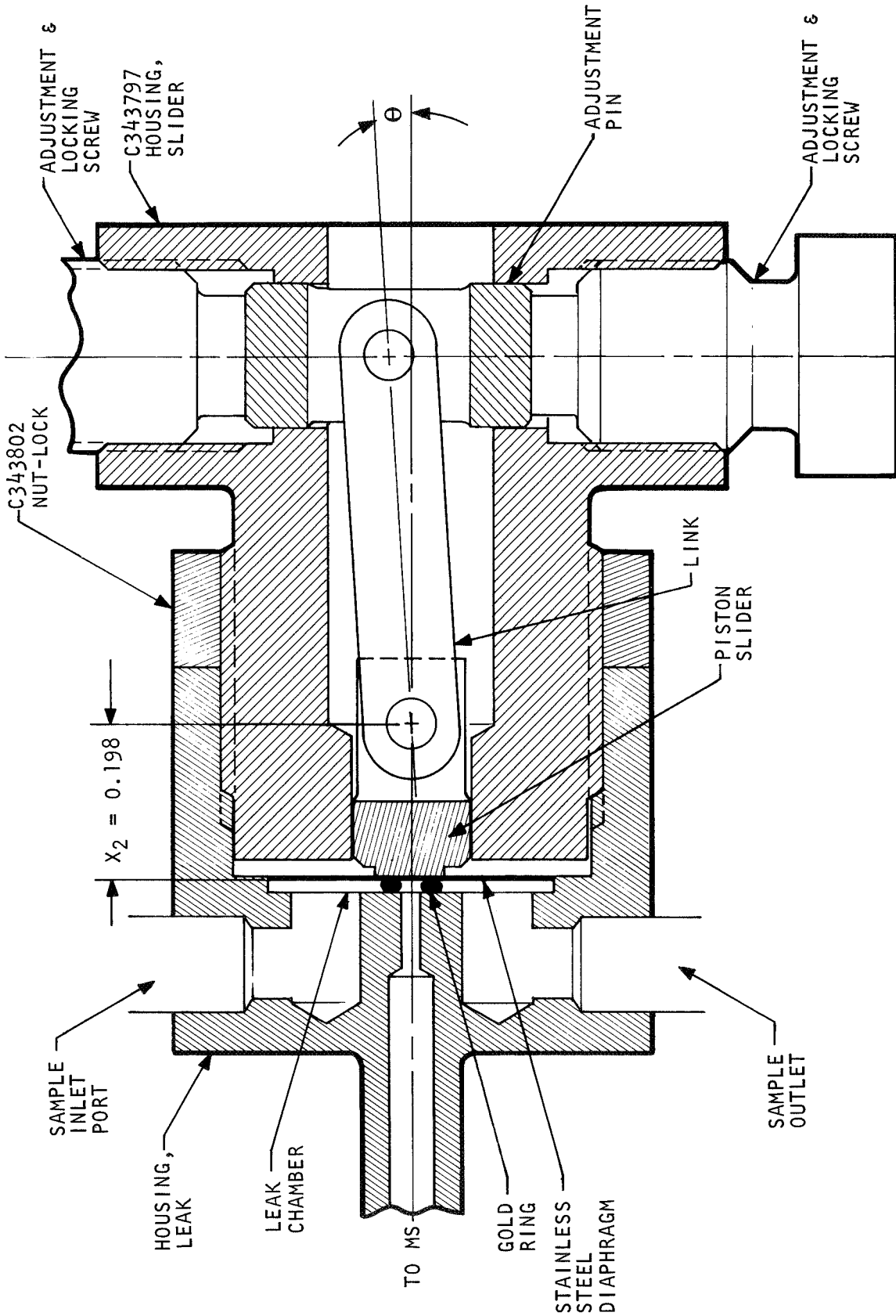

FIGURE 3.- Leak Assembly, Piston Drive



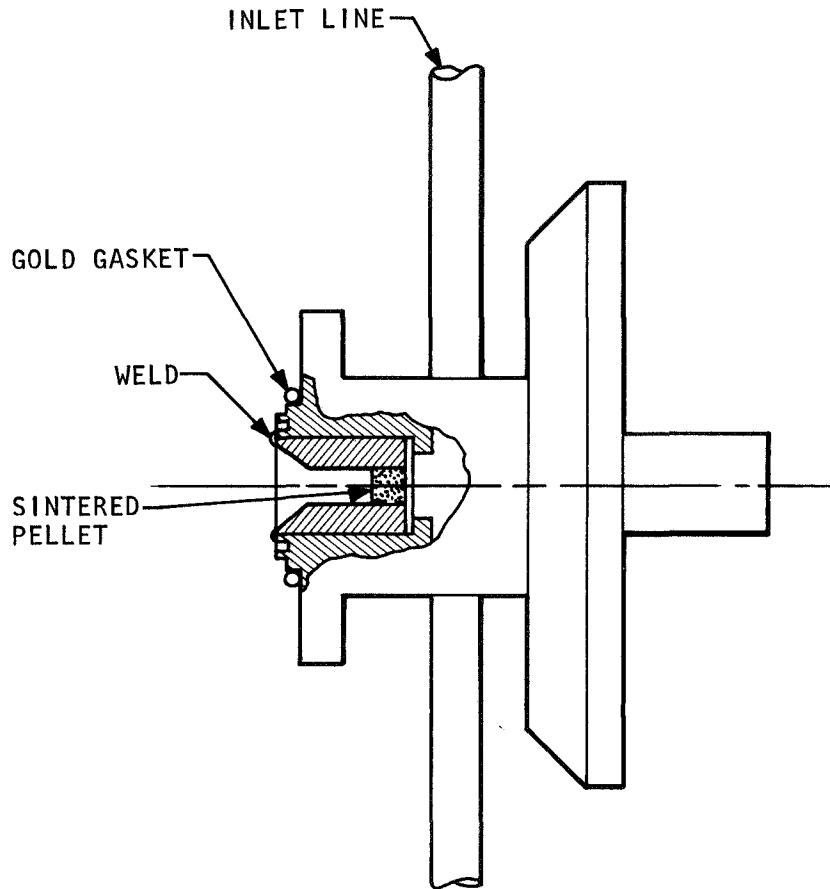
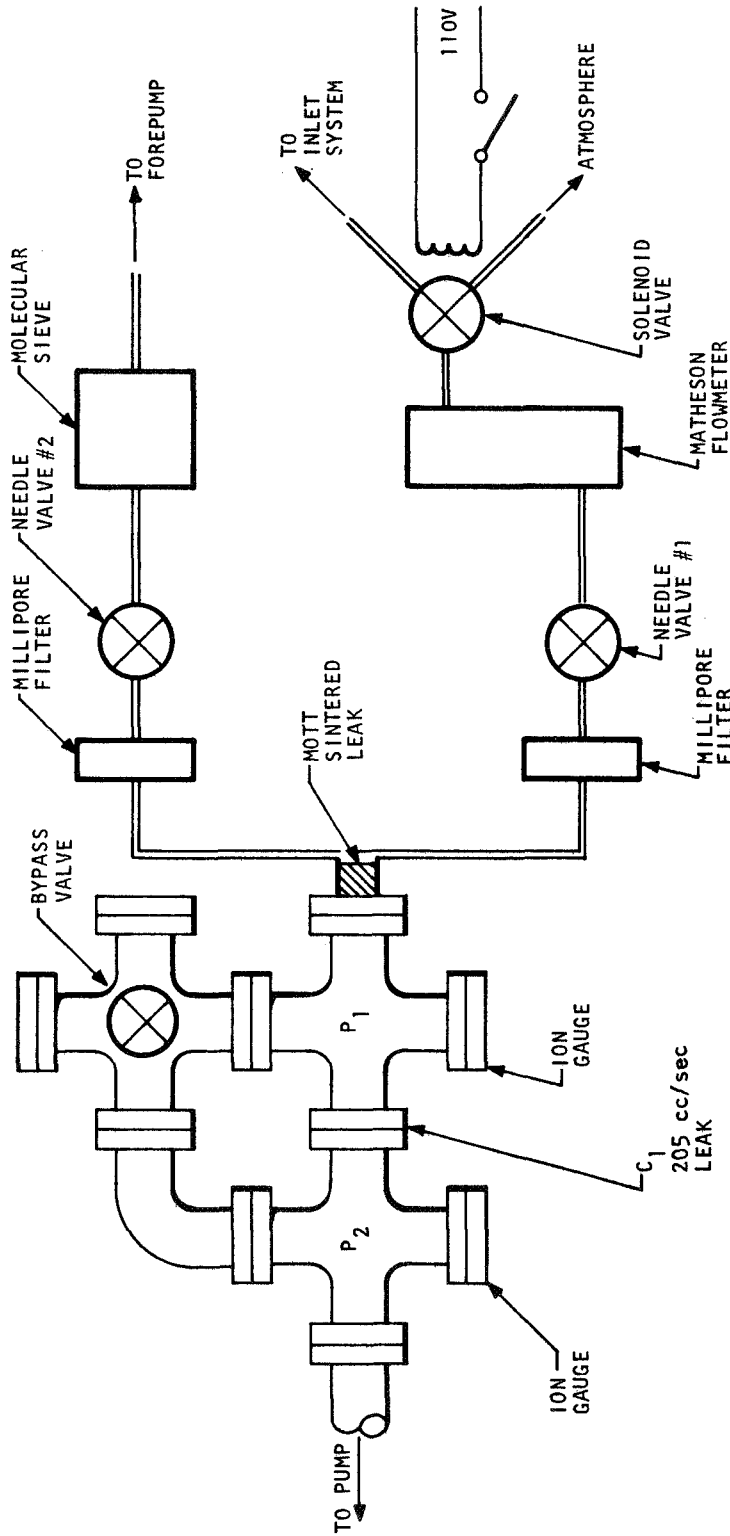

FIGURE 4.- Modified Valve Body With Sintered Leak Welded in Place



NOTE: VOLUME OF LINES BETWEEN NEEDLE VALVES AND LEAK IS MINIMIZED BY USING 1/8" O.D. ALL OTHER LINES ARE 1/4" OR LARGER.

FIGURE 5.- Apparatus for Measuring Time Response and Long-Term Stability of Mott Sintered Leak

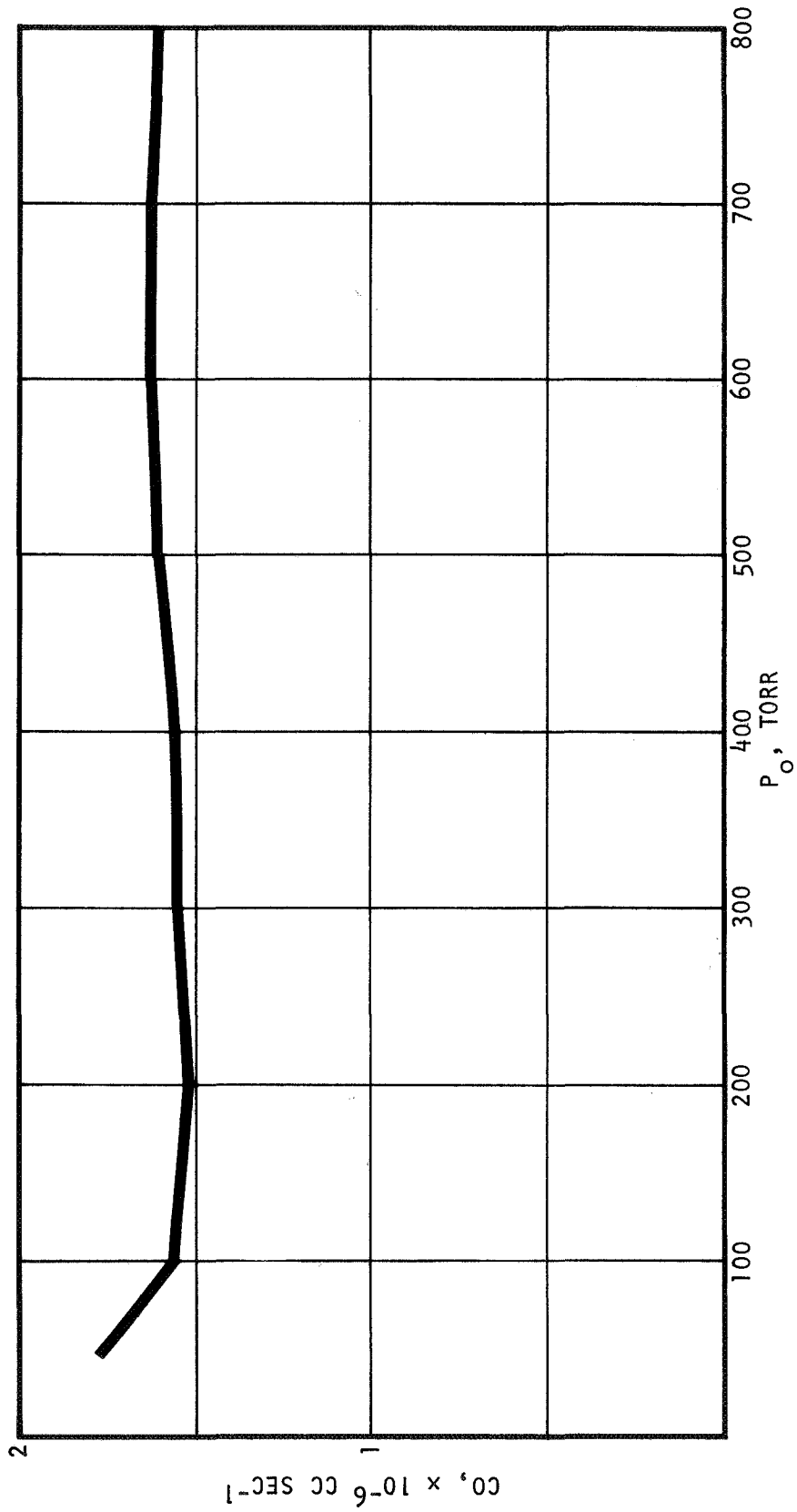

FIGURE 6.- Conductance of Sintered Leak at Pressure Differentials Below 1 Atmosphere

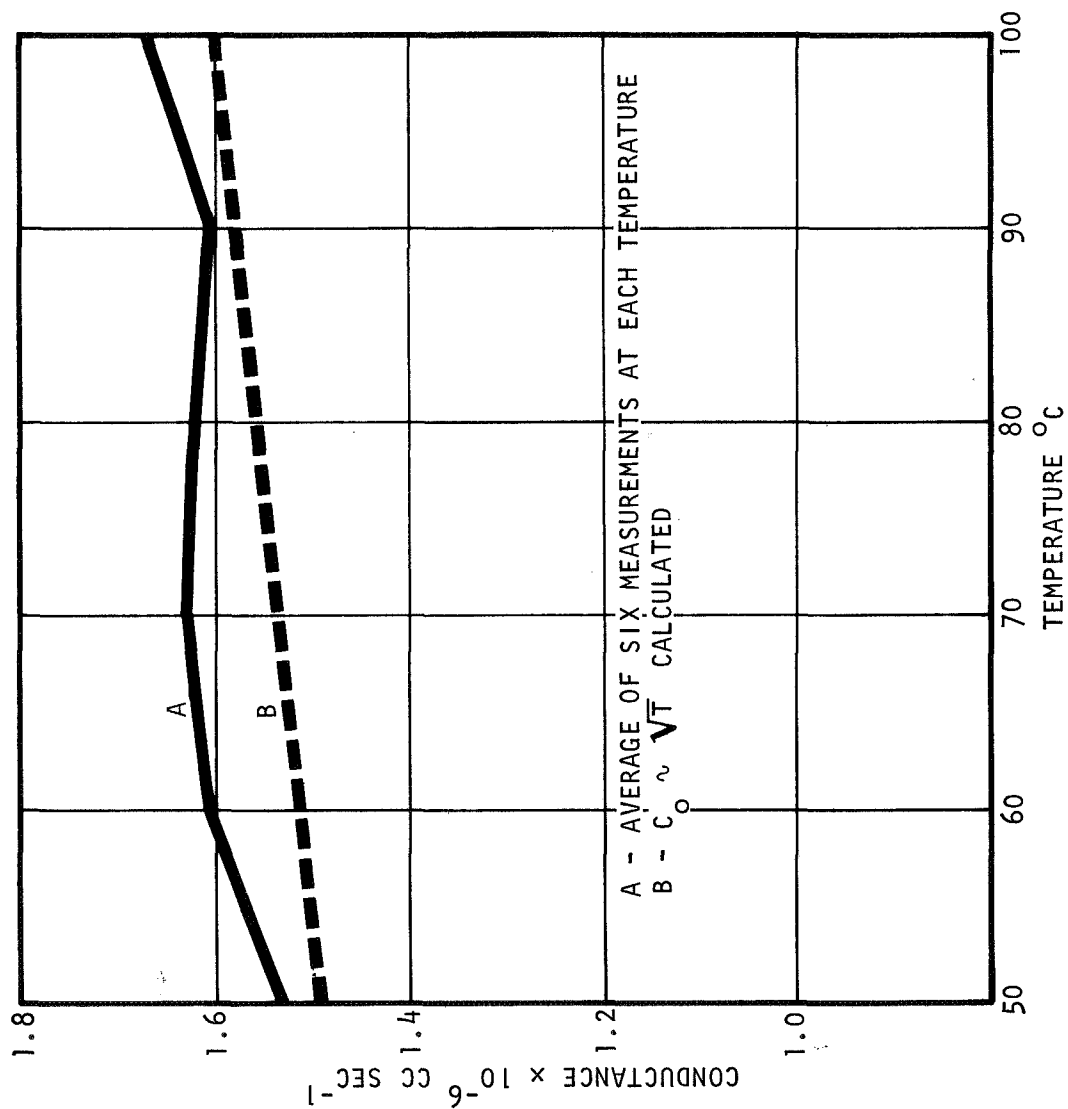

FIGURE 7.- Temperature Coefficient of Sintered Leak

NOTE: AT TIME  $T = 0$ , THE FLOW WAS CHANGED FROM  $50 \text{ CC MIN}^{-1}$  AT 250 TORR TO  $100 \text{ CC MIN}$  AT 500 TORR. CALCULATED CONSTANTS OF THIS SYSTEM ARE: INLET DELAY: 0.1 SEC, LEAK DELAY: 0.5 SEC., CHAMBER FILL RATE;  $5 \times 10^{-6} \text{ TORR SEC}^{-1}$ .

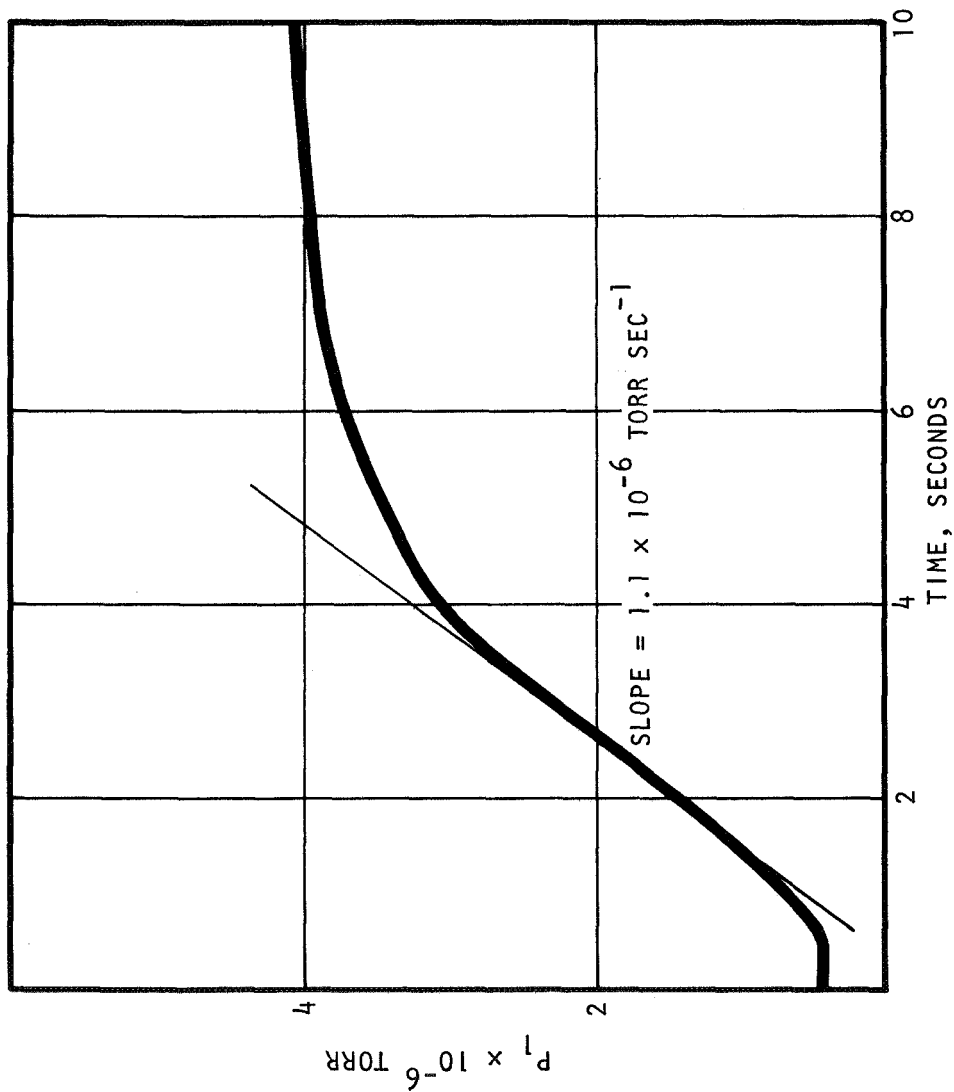

FIGURE 8.- Time Response of Filters and Leak Assembly

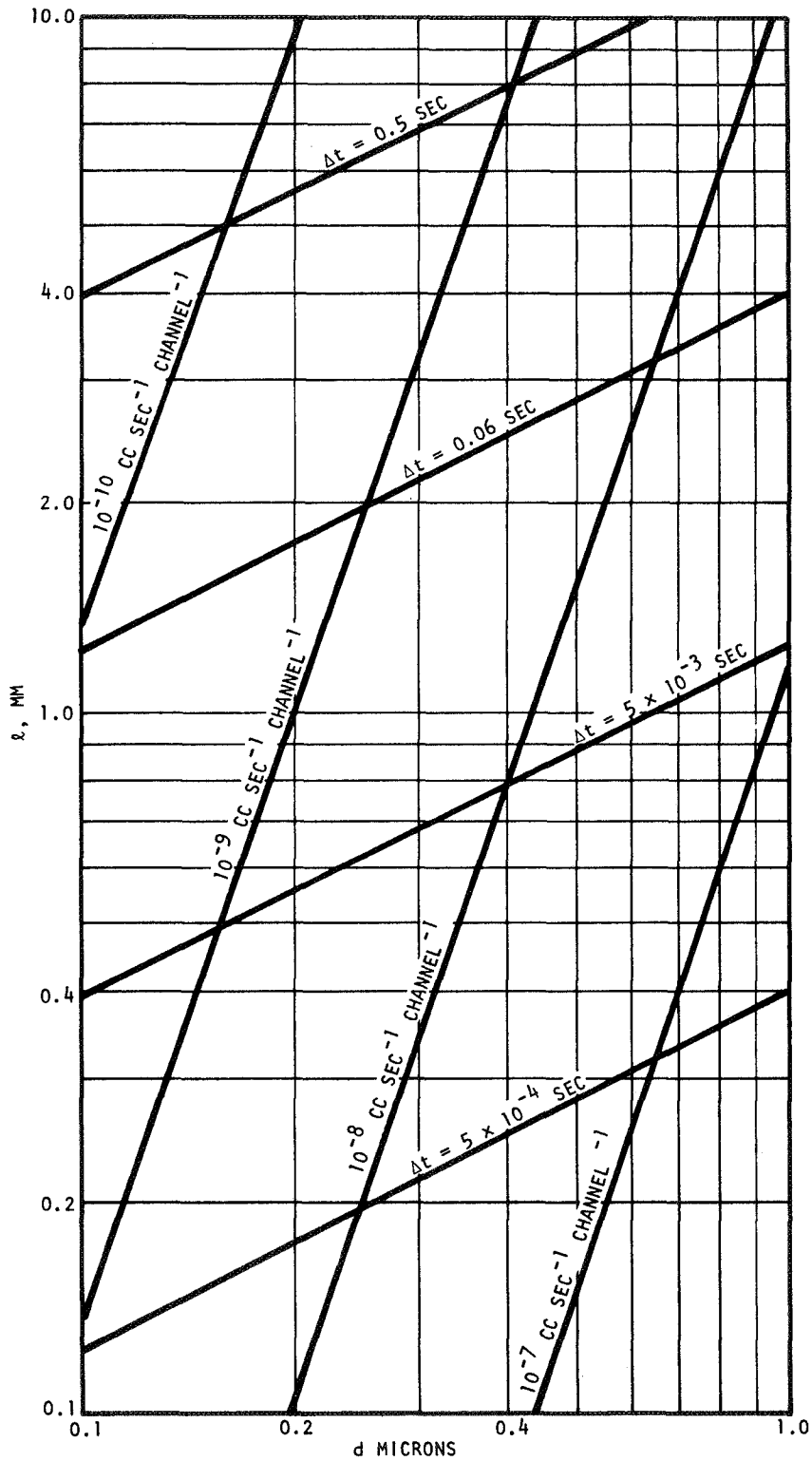

FIGURE 9.- Conductance and Time Delay of Molecular Flow Through a Channel  $d$  Microns, Diameter,  $l$  mm Long

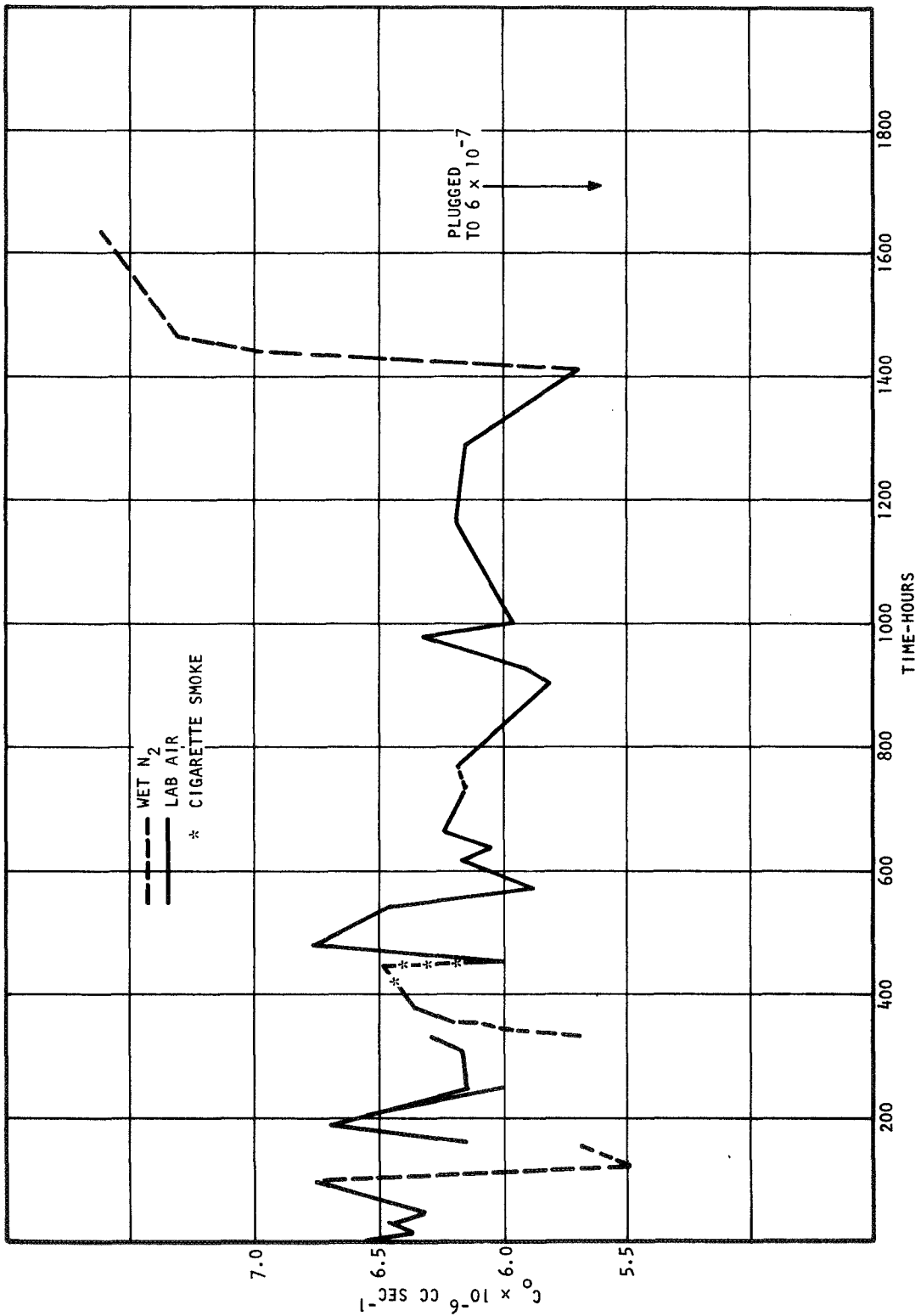

FIGURE 10.- Long-Term Test of Sintered Leak

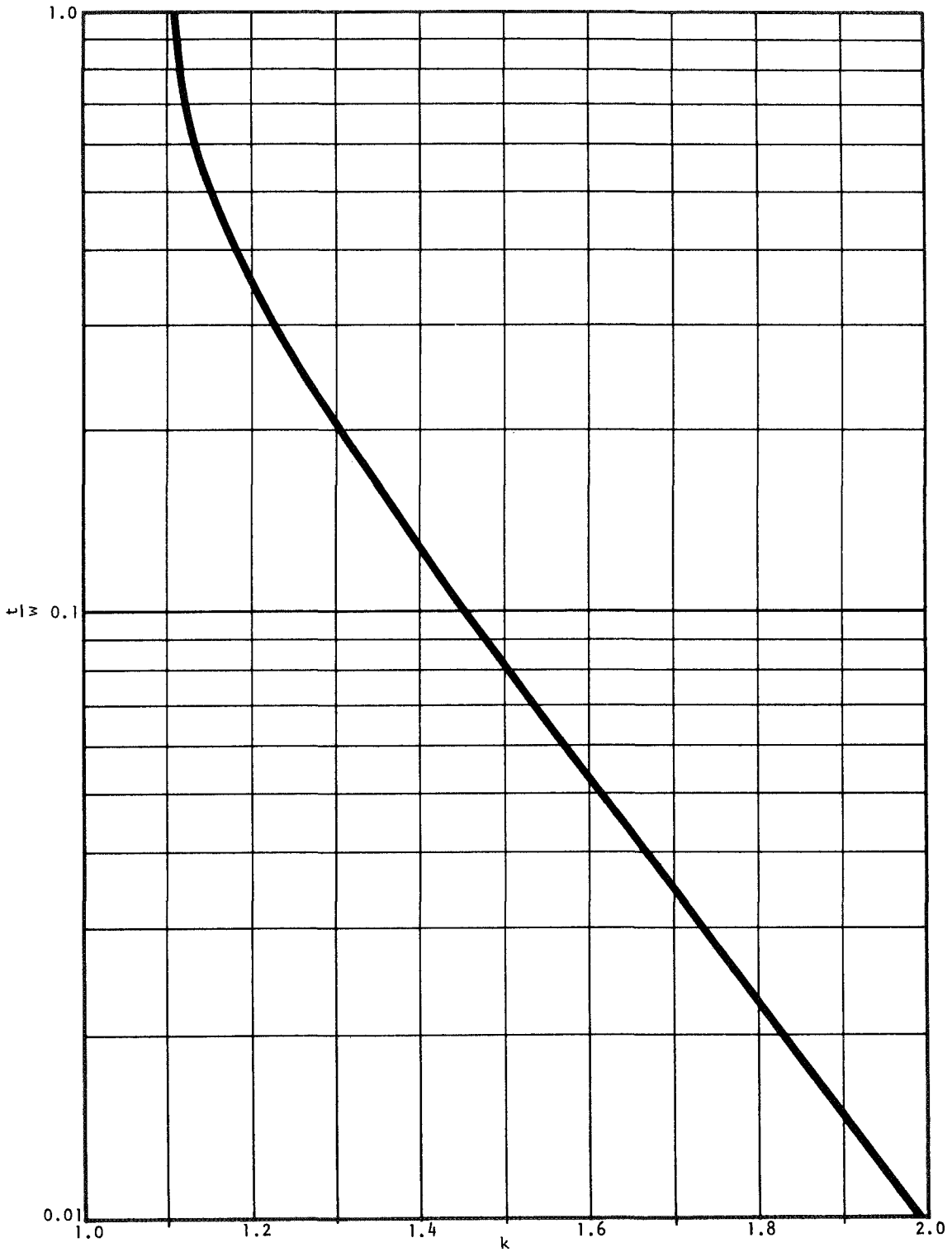

FIGURE 11.- Graph (Design Analysis of Ball Leak) of Geometry Factor  $K$  vs Leak Height to Width Ratio  $t/w$