

# CASE FILE COPY

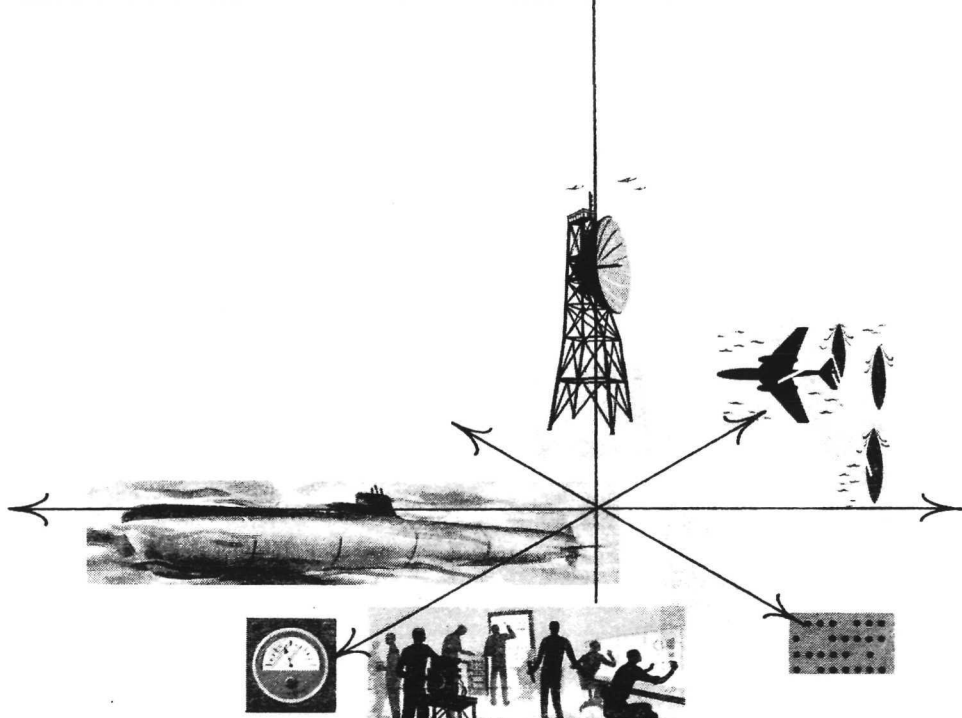

N72-11159

Final Report  
on  
SURFACE ELASTIC WAVE DETECTORS



THE **Magnavox** COMPANY  
GOVERNMENT AND INDUSTRIAL DIVISION

ASW-345

N72-11159

Final Report  
on  
SURFACE ELASTIC WAVE DETECTORS

Final report covering the period 26 June to 26 October, 1971  
Published October 28, 1971

Prepared under Contract NAS8-27800  
for  
MARSHALL SPACE FLIGHT CENTER  
Huntsville, Alabama

Prepared by:

Ronald L. Lawson

Ronald L. Lawson  
Senior Engineer  
Advanced Development Technology

THE **Magnavox** COMPANY  
GOVERNMENT ELECTRONICS DIVISION  
ASW OPERATION  
Fort Wayne, Indiana

## TABLE OF CONTENTS

| <u>Paragraph</u> | <u>Title</u>   | <u>Page</u> |
|------------------|--|-------------|
|                  | PREFACE .....  | iv          |
| 1.0              | INTRODUCTION .....                                   | 1-1         |
| 2.0              | ACOUSTIC SURFACE WAVE TECHNOLOGY .....               | 2-1         |
| 2.1              | Surface Wave Tapped Delay Lines (SWTDL's) .....      | 2-1         |
| 2.2              | Surface Wave Matched Filter Performance .....        | 2-3         |
| 2.3              | Modulation/Demodulation Techniques .....             | 2-14        |
| 2.4              | Programmable Surface Wave Tapped Delay Line .....    | 2-25        |
| 3.0              | SELECTED APPLICATIONS OF SURFACE WAVE TECHNOLOGY ... | 3-1         |
| 3.1              | Spread Spectrum Transceiver .....                    | 3-1         |
| 3.2              | Acoustic Surface Wave Modem .....                    | 3-4         |
| 3.3              | Code Multiplex Transceiver .....                     | 3-15        |
| 3.4              | Multiple Code Synthesizer .....                      | 3-30        |
| 4.0              | BREADBOARD SURFACE WAVE TAPPED DELAY LINES .....     | 4-1         |
| 4.1              | Code 2 Devices .....                                 | 4-1         |
| 4.2              | Code 4 Devices .....                                 | 4-4         |
| 4.3              | Breadboard Performance Data .....                    | 4-12        |

## LIST OF TABLES

| <u>Table</u> | <u>Title</u>                                   | <u>Page</u> |
|--------------|--|-------------|
| 2-1          | Substrate Materials and Characteristics .....  | 2-12        |
| 2-2          | Characteristics of Modulation Techniques ..... | 2-24        |
| 3-1          | Breadboard Operational Data .....              | 3-15        |
| 4-1          | Comparison Data .....                          | 4-13        |

## LIST OF ILLUSTRATIONS

| <u>Figure</u> | <u>Title</u>   | <u>Page</u> |
|---------------|--|-------------|
| 2-1           | Basic Tapped Delay Line .....                                | 2-2         |
| 2-2           | Multitap Transducer With Tapped Conductor Pairs ....         | 2-2         |
| 2-3           | Processing Gain of SWTDL .....                               | 2-4         |
| 2-4           | Sources of SWTDL Matched Filter Degradation .....            | 2-6         |
| 2-5           | Processing Gain Loss Due to Pre-Transmission<br>Filter ..... | 2-7         |
| 2-6           | SWTDL Matched Filter .....                                   | 2-8         |

LIST OF ILLUSTRATIONS (CONT)

| <u>Figure</u> | <u>Title</u>  | <u>Page</u> |
|---------------|---|-------------|
| 2-7           | Processing Gain Variation Due to Matched Filter Bandlimiting .....  | 2-8         |
| 2-8           | Processing Gain Loss Due to Sampling Pulse Width ...  | 2-10        |
| 2-9           | Autocorrelation Peak Degradations .....   | 2-13        |
| 2-10          | Correlation Peak Degradation Versus Temperature ....  | 2-14        |
| 2-11          | Pulse Amplitude Modulation .....  | 2-16        |
| 2-12          | PSK Modulation of Surface Wave Device Impulse Response .....  | 2-18        |
| 2-13          | Surface Wave Device Phase Shift Key Modulation System .....   | 2-19        |
| 2-14          | Coherent PSK Technique .....  | 2-20        |
| 2-15          | Differential Phase Shift Keying Technique .....   | 2-21        |
| 2-16          | Double Pulse Mode Phase Shift Keying Technique ....   | 2-22        |
| 2-17          | Code Pair Phase Shift Keying Technique .....  | 2-23        |
| 2-18          | Programmable SWTDL (Breadboard Version) .....   | 2-26        |
| 2-19          | A p-i-n Diode Polarity Switch for a Delay-Line Tap .....  | 2-26        |
| 2-20          | Tap Polarity Switch in Normal Polarity State: (a) Detailed Equivalent Circuit (b) Simplified Equivalent Circuit ..... | 2-27        |
| 2-21          | Impulse Response Oscillograms .....   | 2-28        |
| 2-22          | Sequence Generator Output Oscillograms .....  | 2-30        |
| 3-1           | Spread Spectrum Transceivers .....  | 3-1         |
| 3-2           | Diagram of a Generalized Tapped Delay Line .....  | 3-2         |
| 3-3           | Experimental Transceivers Using SWTDL's .....   | 3-4         |
| 3-4           | Low Detectability Transceiver, Block Diagram .....  | 3-5         |
| 3-5           | Graph Showing Encoder-Decoder Processing Gain ....  | 3-6         |
| 3-6           | Concept of Modem Implementation .....   | 3-7         |
| 3-7           | Transmitter (Coherent PSK Mode) .....   | 3-9         |
| 3-8           | Timing Diagram of DRSS Transmitter .....  | 3-10        |
| 3-9           | Receiver (Coherent PSK Mode) .....  | 3-11        |
| 3-10          | Timing Diagram of DRSS Receiver .....   | 3-12        |
| 3-11          | Basic Concept of a Code Multiplex Transceiver ....  | 3-16        |
| 3-12          | Proposed Spread Spectrum Communication Link .....   | 3-17        |
| 3-13          | Surface Wave Signal Generator .....   | 3-19        |
| 3-14          | Surface Wave Matched Filter Detection .....   | 3-20        |
| 3-15          | Simultaneously Transmitted Wideband Signals .....   | 3-24        |
| 3-16          | Demonstration of Address Selection Capability ....  | 3-25        |
| 3-17          | Communications Link Using Simultaneously Transmitted Wideband Signals .....   | 3-26        |
| 3-18          | Detecting Weak Signal in the Presence of Strong Pulses .....  | 3-29        |
| 3-19          | Synthesizer Functional Diagram .....  | 3-31        |

LIST OF ILLUSTRATIONS (CONT)

| <u>Figure</u> | <u>Title</u>   | <u>Page</u> |
|---------------|--|-------------|
| 4-1           | Code 2 Device Grid Layout on Quartz Substrate .....                | 4-1         |
| 4-2           | Spread Spectrum Output of Code 2 Encoder .....                     | 4-2         |
| 4-3           | Expanded View of Spread Spectrum Output of<br>Code 2 Encoder ..... | 4-3         |
| 4-4           | Autocorrelation Output From Decoder .....                          | 4-4         |
| 4-5           | Expanded View of Autocorrelation Peak .....                        | 4-5         |
| 4-6           | Code 2 Surface Wave Devices (Encoder and<br>Decoder) .....         | 4-5         |
| 4-7           | Code 2 Surface Wave Device (Encoder with cover<br>Removed) .....   | 4-6         |
| 4-8           | Code 2 Surface Wave Device (Decoder Package) .....                 | 4-6         |
| 4-9           | Test Input Pulse .....   | 4-7         |
| 4-10          | Code 4 Surface Wave Devices (Encoder and<br>Decoder) .....         | 4-8         |
| 4-11          | Double Pulse Mode PSK Technique .....                              | 4-10        |
| 4-12          | Superimposed Signal Modulation Technique<br>Modulator .....        | 4-11        |
| 4-13          | Coherent Phase Shift Keyed Detector .....                          | 4-11        |
| 4-14          | S/N Ratio Performance of Various Modulation<br>Techniques .....    | 4-12        |

## PREFACE

The principal objectives of this program are to characterize certain aspects of surface wave technology having relevance to data-bus type systems and to design and deliver laboratory breadboard surface wave tapped delay lines for use in evaluating various concepts for applying surface wave technology to these systems.

The work performed under this contract includes the design and fabrication of two matched pairs of surface wave tapped delay lines (SWTDL's). Each pair of laboratory breadboard devices is fabricated on ST-cut quartz substrates with a different 127-chip biphas coding. One matched pair has the capability of operating using a superimposed signal modulation technique (pulse-pair modulation). This technique uses multiple pulses to excite the surface wave devices and allows recovery of baseband signals without the need for a reconstructed phase-locked carrier.

The SWTDL's are designed to have the following operational characteristics:

|                  |        |
|------------------|--------|
| Center Frequency | 32 MHz |
| Signal Bandwidth | 8 MHz  |
| Dynamic Range    | 45 dB  |
| Insertion Loss   | 0 dB   |

Insertion loss is defined as

$$\text{Insertion Loss} = 20 \log \frac{\text{correlation voltage peak}}{\text{spread spectrum input voltage}}$$

Low insertion loss is obtained by including active matching networks in each SWTDL package. These devices were delivered at the end of the contract period.

Certain additional developments resulting from other Magnavox investigations of surface wave technology, especially those dealing with applications relevant to multiplex and other types of communication systems have been documented, are included in this final report. These developments include: a programmable delay line, a spread spectrum transceiver, a bench model acoustic surface wave modem capable of operating in both the pulse pair and coherent PSK modes, a code multiplex transceiver, and a multiple code frequency hopper.

The contract called for a three day seminar, which was held at the contractor facility, to discuss system characteristics of surface wave devices and to demonstrate various applications of surface wave technology.

The results of this effort indicate that there is a potential for the application of surface wave technology in data-bus type systems. Further investigations and more specific system requirements are needed to determine the extent of this potential.

## 1.0 INTRODUCTION

Acoustic surface wave technology has potential applications in multiplex communication systems such as the data-bus. The goal of this program has been primarily to characterize certain aspects of surface wave tapped delay lines, surface wave modulation techniques, and surface wave applications that are relevant to the evaluation of surface wave devices in multiplex systems.

This report presents a summary of the work performed and the information gathered during the course of Contract NAS8-27800. It also presents the results of certain other investigations and applications of surface wave technology performed by Magnavox.

The primary emphasis of this report is on Surface Wave Tapped Delay Lines (SWTDL's) and their use as matched filters. In view of this, a general discussion of SWTDL's is first presented. Technical considerations concerning the performance of surface wave matched filters are discussed in Section 2.0, subsection 2.2. Processing gain is defined, i.e., the theoretical processing gain is presented and factors responsible for reduction of processing gain in SWTDL's are discussed. Some of these factors are bandwidth narrowing, sampling pulse width, various noise sources, and environmental effects such as temperature and doppler.

Modulation/demodulation techniques used to transfer data to and from the spread spectrum signals generated on the acoustic devices are presented in Section 2.0, subsection 2.3. These include pulse amplitude modulation, pulse position modulation, pulse rate modulation, coherent phase shift keying, differentially-coherent phase shift keying, double pulse mode phase shift keying, and code pair phase shift keying.

Section 2.0, subsection 2.4 reports on an experimental, electronically programmable switchable 13-tap delay line which uses p-i-n diode tap polarity switches.

Several system applications are reported on in Section 3.0. This section contains descriptions of operation for the spread spectrum transceiver, a bench model acoustic surface wave modem, a code multiplex transceiver, and a multiple code frequency hopper.

The concluding section, Section 4.0, includes a description of and the test data from four SWTDL's which were designed and fabricated under the contract.

## 2.0 ACOUSTIC SURFACE WAVE TECHNOLOGY

Acoustic surface waves are elastic waves that propagate along the boundary between two media. Their existence was first predicted by Lord Rayleigh in 1885, and for many years they were studied primarily by those interested in their geophysical implications in connection with seismic events. After it was demonstrated that acoustic surface waves can be launched and detected on piezoelectric substrates using thin metallic film grating patterns, a great deal of interest in utilizing them for electronic device applications arose.

The waves propagate at a velocity approximately five orders of magnitude slower than electromagnetic waves; and they can be tapped, guided, and spatially processed on small substrate devices fabricated using many of the planar processing techniques used in the manufacture of integrated circuits. These factors combine to make this technology attractive for a number of signal processing components and account for much of the new interest in these waves.

### 2.1 Surface Wave Tapped Delay Lines (SWTDL's)

The acoustic SWTDL is fundamental to all of the devices discussed in this report. Therefore, the nature of SWTDL's is briefly reviewed to establish a basis for later discussion of applications.

Piezoelectric materials can be used effectively as the propagation medium for surface waves, with direct rf-to-acoustic conversion obtained by applying electrical signals to thin film conductors deposited on the surface. Since acoustic surface waves propagate 100,000 times slower than electromagnetic waves, they provide a compact means of information storage. The surface wave energy is concentrated near the surface and can be accessed at any point along the acoustic path, allowing fabrication of multitapped delay line processors with extremely simple geometries. Such surface wave devices are compact, rugged, reliable, and reproducible.

In the basic delay line shown in Figure 2-1, an electrical impulse applied between thin film conductors causes a mechanical stress in the piezoelectric substrate. This stress propagates as a surface wave along the length of the substrate with a typical velocity of three millimeters per microsecond. This traveling wave has associated with it an electrical field which extends away from the surface, and induces a voltage pulse between adjacent conducting output grids that is delayed with respect to the input pulse by the propagation time between the input and output grids.

A multitap output transducer is realized by placing conductor pairs along the propagation path and interconnecting them so as to sum their outputs (see Figure 2-2). The impulse response is a periodic burst of rf energy with a frequency dependent upon the wave velocity and conductor pair separation. The burst duration is determined by the wave velocity and the length of the propagation path under the output transducer.



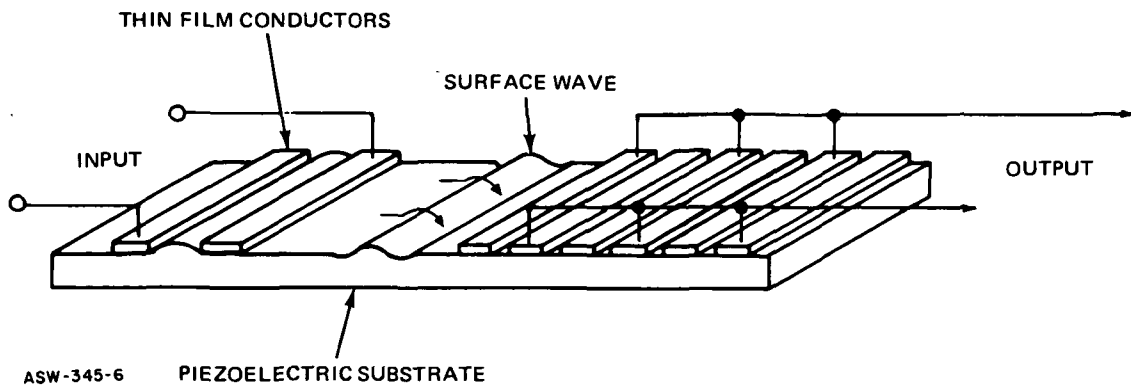

Figure 2-1. Basic Tapped Delay Line

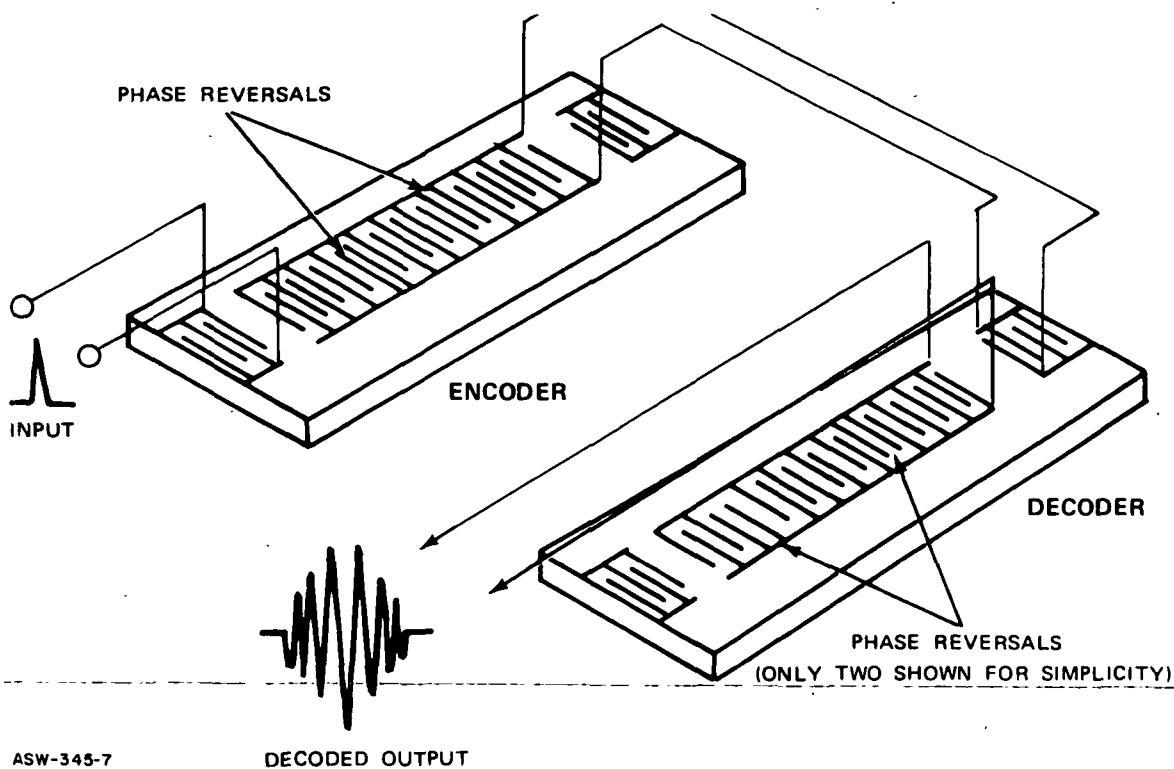

Figure 2-2. Multitap Transducer With Tapped Conductor Pairs

SWTDL's can be designed to have an arbitrary impulse response by appropriate choice of the number, spacing, and overlap of the tap interdigital conductors.

Reversing the multitap transducer alternation pattern results in a phase reversal in the periodic output signal. If the tap pattern reversals are positioned along the acoustic path in accordance with a pseudorandom code, the impulse response will be a phase shift keyed (PSK) pseudonoise (PN), spread spectrum rf signal.

The optimum detector for this signal is a matched filter which has precisely the same impulse response, but with a reversed time argument. This is obtained by using a second SWTDL with an output transducer identical to the one used on the first SWTDL, but having the input transducer on the opposite end of the code so that the surface waves propagate in the opposite direction through the output taps. The matched filter SWTDL produces a correlation pulse, as shown in Figure 2-2, in response to the signal generated by the transmitter SWTDL.

A continuous envelope rf spread spectrum signal is generated when a series of pulses is applied to the input terminal of a SWTDL if the pulse repetition period equals the SWTDL impulse response duration. Information can be encoded onto this rf signal by varying either the rate, amplitude, polarity, or relative position of the input pulses.

When a SWTDL is used as a signal generating element, its matched filter mate produces one output correlation pulse for every input pulse. Since the system is linear, the amplitude and phase of each output pulse is directly related to the input pulse and polarity even if two or more time expanded coded signals overlap or if they are separated by large gaps.

## 2.2 Surface Wave Matched Filter Performance

The performance of carefully designed SWTDL's is very near the optimum theoretical level when used as a matched filter signal processor. Some of the factors affecting SWTDL matched filter performance in communications links will now be discussed along with certain modulation methods available for use with these devices.

### 2.2.1 Processing Gain Definition

In spread spectrum communication links, the SWTDL can be used as a matched filter for the signals transmitted to the communication link receiver. A typical SWTDL matched filter receives the desired signal which is contaminated by interfering signals (noise), see Figure 2-3.

Interfering signals, in this context, may be considered as receiver (thermal) noise, atmospheric noise, narrowband RFI, and wide-band jamming signals.

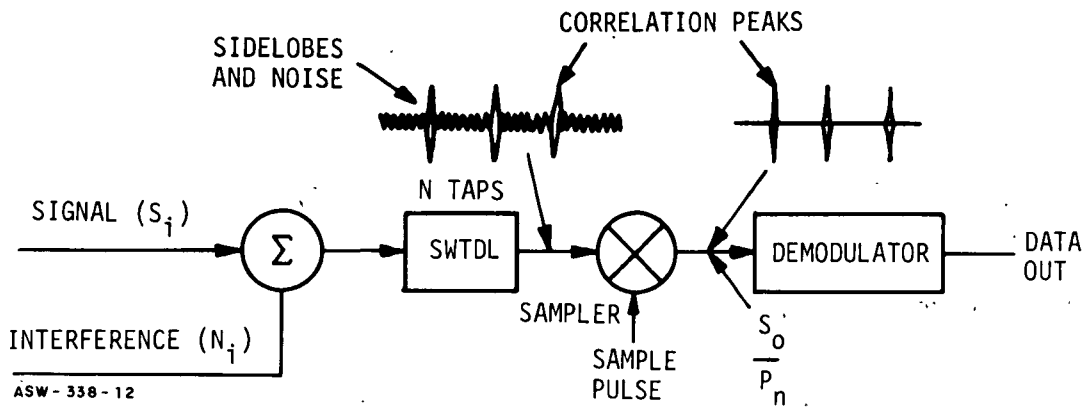

Figure 2-3. Processing Gain of SWTDL

The matched filter processes the signal and produces a correlation peak. The information content of the signal is contained in the correlation peak and, as mentioned previously, the correlation peak is a triangular-shaped pulse which rises above a lower rather continuous envelope (noise) signal.

If a sampler samples the correlation peak at its maximum point, the ratio of signal power to noise power in the sample is related to the input signal-to-noise ratio by the matched filter processing gain. The processing gain (PG) is defined as

$$PG = \frac{S_o}{P_n} \frac{N_o}{S_i T}$$

where  $S_o$  = sampled output signal power

$P_n$  = sampled output noise power

$N_o$  = input independent noise spectral density

$S_i$  = input power

$T$  = Tap-to-tap time delay of the SWTDL matched filter

In addition to the main correlation peak, the SWTDL matched filter also contains smaller peaks called sidelobes. In a communication system, a properly implemented sampler discriminates against these sidelobes because it samples only at the peak of the triangular-shaped correlation pulse. It is important to note that no signal-to-noise improvement (processing gain) is realized if the sampler is eliminated.

### 2.2.2 Theoretical Processing Gain in SWTDL Devices

A perfect SWTDL matched filter, followed by an ideal (zero width) sampler, provides a signal-to-noise improvement equal to the number of taps (N) incorporated into the SWTDL. This is shown in the mathematical definition of a matched filter process which states

$$\frac{\text{Sampled Signal Power}}{\text{Sampled Noise Power}} = \frac{h(t) * h(-t)}{n(t) * h(-t)} = \frac{NTS_i}{N_o}$$

where:  $h(t)$  = input signal

$h(-t)$  = ideal SWTDL impulse response, ie., the negative time argument of the signal

$n(t)$  = noise

$N$  = number of taps on SWTDL matched filter

$T$  = tap-to-tap time delay of SWTDL matched filter

$N_o$  = input noise power

$S_i$  = input signal power

$*$  = time convolution

Since the input signal-to-noise ratio is  $(S_i T/N_o)$ , the theoretical processing gain is

$$PG = N$$

### 2.2.3 Realizable Processing Gain

The processing gain of a real SWTDL matched filter is less than the theoretical value if the height of the correlation peak (signal power) is diminished or if the noise level is increased by internal noise sources. The possible sources of processing gain deterioration in SWTDL's are depicted in Figure 2-4.

The first four items, in the illustration, reduce the processing gain S/N improvement because the signal correlation peak height is reduced. Excessive band-limiting of the signal in matching networks and in the SWTDL interdigital transducers can cause a processing gain loss of up to 5 dB.

Samplers with finite width sampling pulses not occurring precisely at the right sampling instant reduce the correlation peak height.

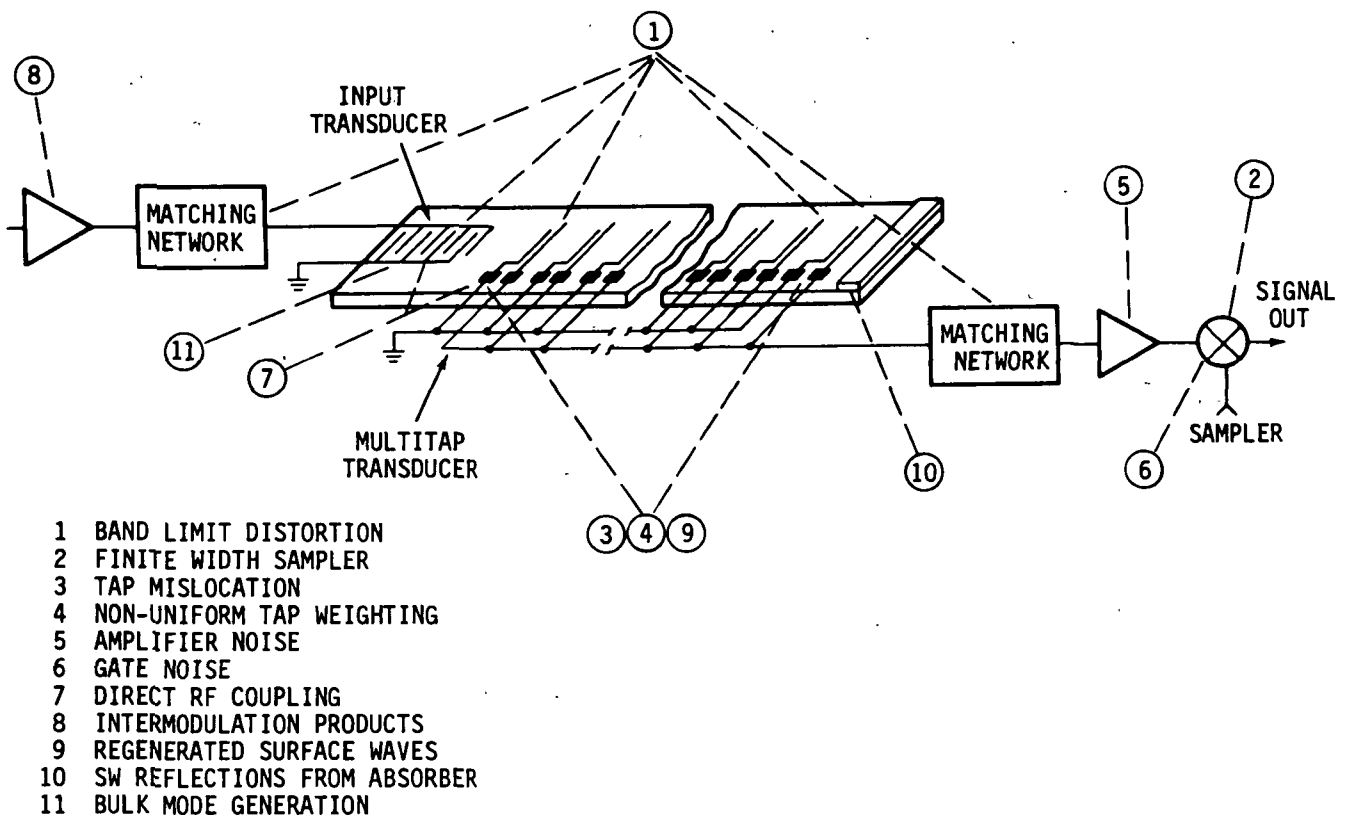

ASW - 338 - 51

Figure 2-4. Sources of SWTDL Matched Filter Degradation

The correlation peak height will also be diminished if the SWTDL matched filter impulse response is not precisely the negative time argument of the incoming signal. To provide a perfect impulse response, each tap must be precisely located on the SWTDL substrate. The SWTDL must also be precisely fabricated to have consistent gain (or insertion loss).

The last seven items, in the illustration, represent noise contributed by the system which also reduces the effective processing gain. Typical SWTDL devices are designed with the objective of maintaining these noise levels 10 to 15 dB below the processed interference level.

Bandwidth Narrowing. - Pre-transmission filters are required in spread spectrum transmitters in order to avoid interfering with links operating in adjacent channels. The typical PN encoded SWTDL signal generator produces a PN phase shift-keyed cosine wave which has a  $(\sin x/x)^2$  power spectrum centered about the SWTDL center frequency and extending over the entire frequency range. If a perfect brick-wall pre-transmission filter is placed in the transmitter to limit the transmitted signal bandwidth, there will be a loss in processing gain when the signal is processed by the SWTDL matched filter as shown in Figure 2-5.

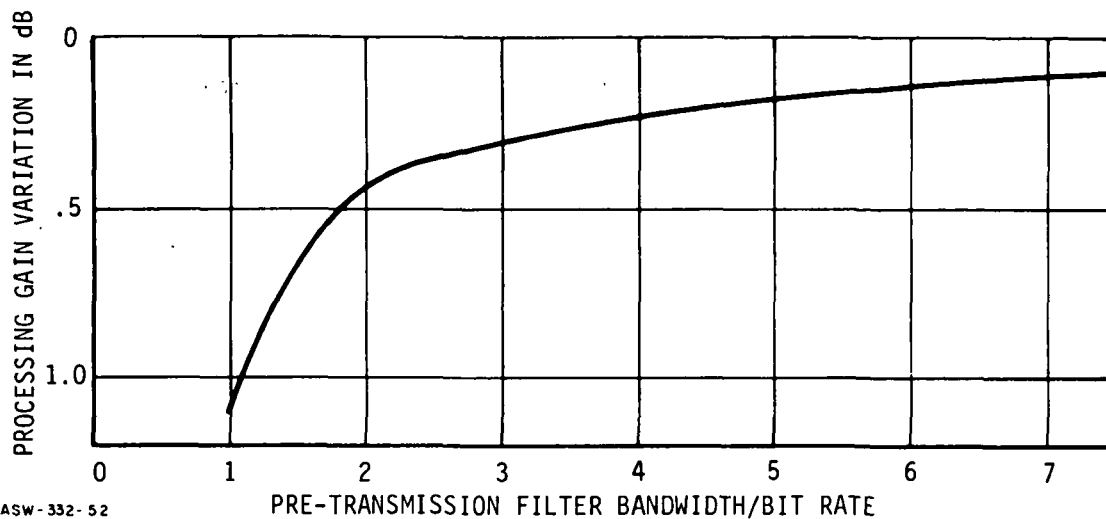

ASW - 332- 52

Figure 2-5. Processing Gain Loss Due to Pre-Transmission Filter

As stated previously, band-limiting caused by the surface wave transducers and matching networks causes a loss of processing gain. A typical SWTDL matched filter is shown in Figure 2-6. A 40-MHz SWTDL center frequency is postulated for discussion purposes. When the 40-MHz signal modulated by an 10-MHz pseudonoise code passes through the transducers and matching networks of the SWTDL, it is band-limited and the processing gain is reduced. Nearly ideal SWTDL matched filters can be constructed by eliminating the matching network and using a four-interdigital-pair input transducer and a single-interdigital-pair per-tap output multi-tap transducer. The processing gain loss of such a SWTDL matched filter (Configuration No. 1) is plotted as a function of pre-transmission bandwidth in Figure 2-7. It suffers less than 0.1 dB loss of processing gain for any pre-transmission bandwidth. It should be noted that the loss of processing gain shown in Figure 2-7 is over and above the processing gain loss from the pre-transmission filter.

Surface wave devices have an inherent insertion loss-bandwidth relationship which makes it desirable to operate them at a minimal bandwidth. The insertion loss of the Configuration No. 1 SWTDL is high because it uses wide bandwidth transducers and no matching networks. An extensive theoretical study\* was made to determine processing gain loss as a function of

- (a) Input matching network bandwidth
- (b) Number of interdigital pairs in the input transducer

---

\*This study was performed under Contract No. NAS-5-20198

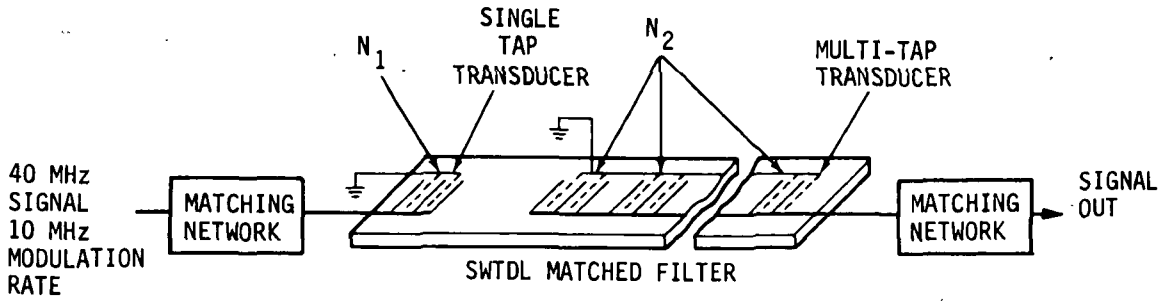

| ---       | BW MATCHING NETWORKS | NO. OF GRID PAIRS/TAP |                |
|-----------|----------------------|-----------------------|----------------|
|           |                      | N <sub>1</sub>        | N <sub>2</sub> |
| CONF NO.1 | ∞                    | 4                     | 1              |
| CONF NO.2 | 13 MHz               | 2.5                   | 2.5            |

ASW-338-20

Figure 2-6. SWTDL Matched Filter

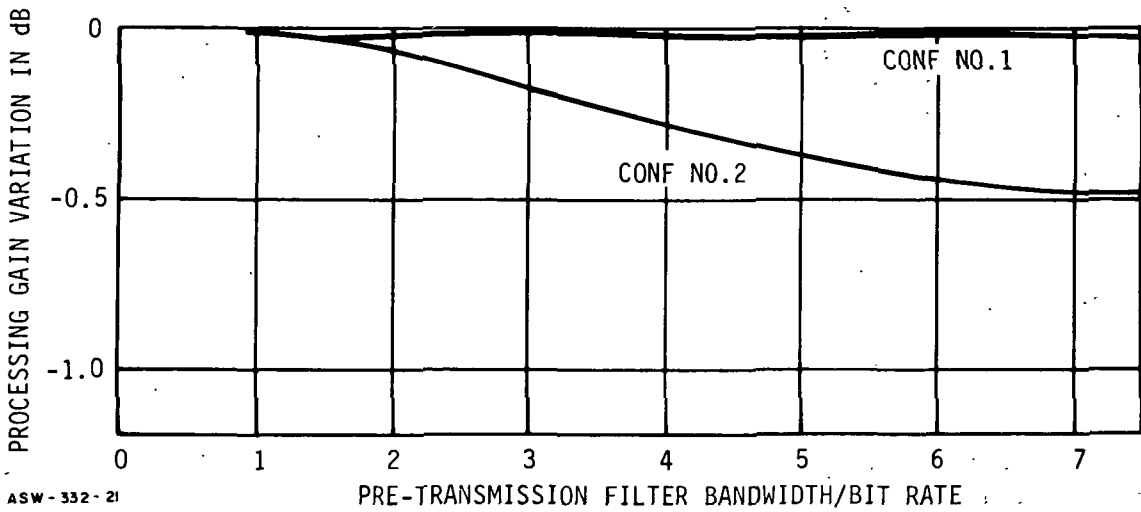

ASW-332-21

Figure 2-7. Processing Gain Variation Due to Matched Filter Band-Limiting

- (c) Number of interdigital pairs per tap in the multi-tap transducer
- (d) Output matching network bandwidth
- (e) Insertion loss.

The study has shown that Configuration No. 2 is the best SWTDL design for use in conjunction with band-limited channels (pre-transmission filter set at the modulation rate). The input transducer and each tap of the output transducer have  $2\frac{1}{2}$  interdigital pairs, and the matching networks are Q-spoiled to have a bandwidth of 13 MHz. The results plotted in Figure 2-7 show that this configuration is no worse than Configuration No. 1 if the pre-transmission filter bandwidth is equal to the bit rate. With wider pre-transmission filter bandwidths, however, correspondingly more loss is contributed to the band-limiting in the transducers and matching networks.

Sampling Pulse Width. - A matched filter provides processing gain only when the output is properly sampled.\*\* The SWTDL output is an amplitude-modulated rf signal which has a distinct maximum value. If a finite width pulse is used to sample the maximum value, the average sampled signal power will decrease with sampler width (especially if the output pulse is sharp). The average sampled noise power does not vary with sampling pulse width because the envelope of the noise out of the SWTDL is constant. Figure 2-8 shows the processing gain loss due to sampling pulse width for the two configurations of Figure 2-6 (with and without pre-transmission filter). Configuration No. 1 (without a pre-transmission filter) requires a very narrow sampling pulse to avoid loss of processing gain. The requirements for Configuration No. 1, with a pre-transmission filter, and for Configuration No. 2 are far less critical.

The sampling pulse width must be sufficiently wide to contain the maximum value of the matched filter output under the worst conditions of sampler phase jitter. Since sampler jitter is typically less than 200 ns and pre-transmission filters are required, degradation due to sampling period is expected to be less than 0.4 dB.

Transducer Fabrication Tolerance. - The signal output from a tapped delay line matched filter is degraded if each of the taps of the multi-tap transducer is not precisely located on the substrate. Surface wave tapped delay lines can be fabricated with taps located within approximately one micrometer of any desired point. This represents approximately  $1/10$  wavelength for a 40-MHz signal. If the randomness about the desired location has a triangular distribution, the loss of processing gain due to tap mislocation is less than 0.2 dB.

Since an ideal PSK signal (before the pre-transmission filter) has a constant envelope, a matched filter designed to detect it must have taps with uniform insertion loss (equal tap weighting). Experimental evidence shows that surface wave devices can be made with tap weight tolerances on the average of five percent; this corresponds to less than 0.2 dB of processing gain degradation.

---

\*\* The Schwartz inequality used in the derivation of matched filter performance is valid only for one point in time.



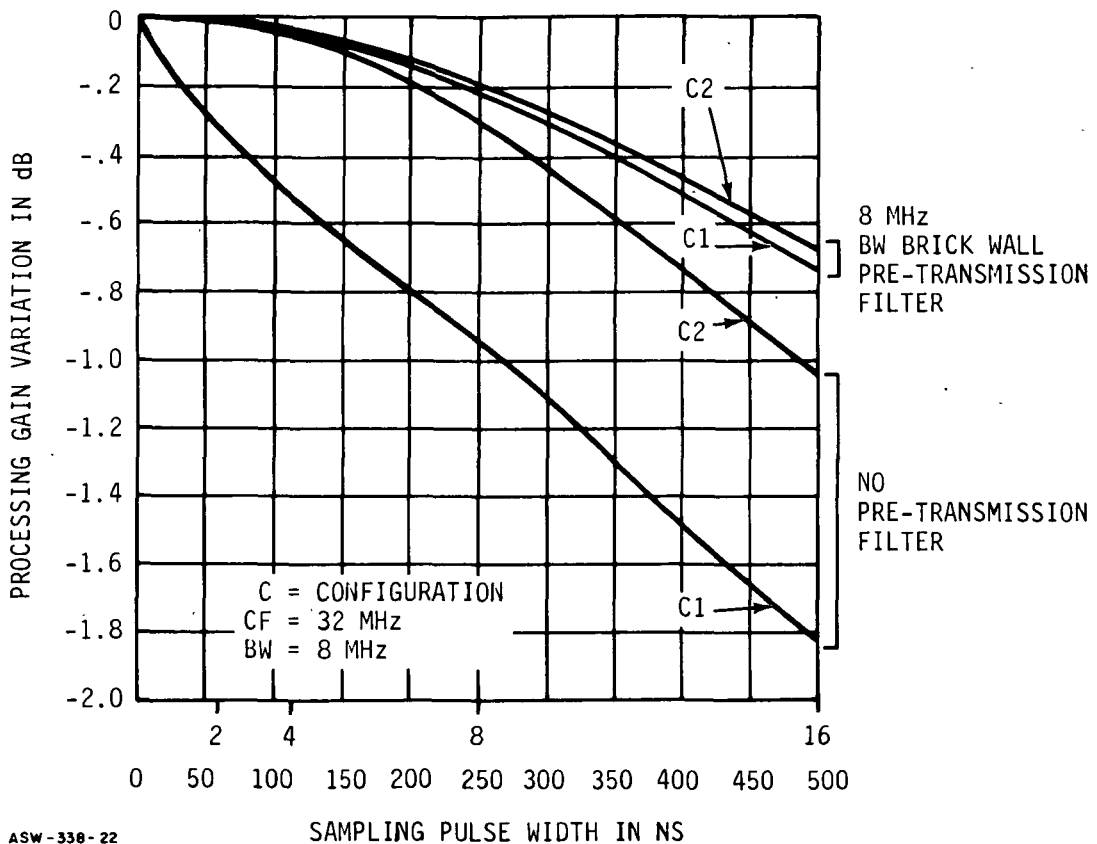

ASW-338-22

Figure 2-8. Processing Gain Loss Due to Sampling Pulse Width

Noise Sources. - The sum of all the internally-generated noise in the matched filter can be made 15 dB, or more, below the desired signal, and less than 0.1 dB of degradation in processing gain results. The following paragraphs briefly describe the seven primary noise contributors.

(a) Amplifier Noise

Surface wave devices have 30 to 70 dB of insertion loss, and care must be taken to assure that the output is well above the thermal noise level of the output amplifier. If a 5 dB noise figure, 13-MHz bandwidth amplifier is used, the thermal noise is -98 dBm. Since the SWTDL matched filter output signals are typically greater than -70 dBm, the amplifier noise is negligible.

(b) Sampler Gate Noise

Commercially available gates used for sampling the correlation peak attenuate the gate switching signal by approximately 48 dB at 30 MHz. Based upon a +7 dBm switching signal and a

-10 dBm correlation peak output signal, gate noise from the sampler is negligible.

(c) Direct RF Coupling

Radiation of signals directly from the input transducer to the multi-tap transducer is another source of noise, but devices have been fabricated which have more than 90 dB of direct rf coupling attenuation. With an insertion loss of 50 dB, the output signal is 40 dB above the direct coupling noise and its effect is negligible.

(d) Intermodulation Products

The intermodulation products of the amplifier which drive the surface wave matched filter also produce a small amount of noise, but these are typically held to approximately 30 dB below the signal. Furthermore, this noise is suppressed by the processing gain of the matched filter, placing it at least 50 dB below the desired signal.

(e) Regenerated Surface Waves

When surface waves propagate under a multi-tap transducer, the voltage generated at each tap will cause new surface waves to be generated at each of the other taps. If strong coupling coefficient materials like lithium niobate are used, the regenerated waves from multi-tap SWTDL's may become significant. However, for ST-cut quartz, the coupling coefficient is sufficiently small enough so that the regenerated noise is at least 60 dB below the desired signal.

(f) Reflections from the Absorber

Surface waves propagating along a substrate are reflected when they encounter the ends of the substrate. Such reflections are insignificant when acoustic absorbing materials are placed at the substrate edges so that the reflections are absorbed and scattered out of the region of the multi-tap transducer.

(g) Bulk Mode Generation

Surface wave transducers generate a small amount of bulk acoustic energy which introduces noise at the multi-tap transducers. However, the level of spurious noise from bulk modes is negligible when carefully designed transducers are used.

Environmental Effects. -

(a) Temperature

The primary performance degradation of SWTDL matched filters with temperature is due to differences in temperature that may occur between the transmitter and receiver devices. The impulse response of a surface wave device depends on the spacing between conductors and the phase velocity of the surface waves propagating on the surface wave device. The overall change in SWTDL center frequency (or delay) as a function of temperature has been determined for a number of different materials some of which are summarized in Table 2-1.

TABLE 2-1. SUBSTRATE MATERIALS AND CHARACTERISTICS

| Material           | Cut       | Propagation Direction | Delay Change in ppm/°C |
|--------------------|-----------|-----------------------|------------------------|
| LiNbO <sub>3</sub> | X         | Z                     | +93                    |
| Quartz             | Rotated Z | X                     | -30                    |
| Quartz             | ST        | X                     | 1                      |
| Quartz             | Rotated Y | X                     | +18                    |
| PZT6               | -         | -                     | +6                     |

Figure 2-9 shows the degradation of the correlation peaks which results when an identical SWTDL signal generator and SWTDL match filter are at different temperatures.

The actual SWTDL processing gain loss as of a function of temperature has been calculated and verified experimentally. The processing gain loss is simply a function of the center frequency-delay-time product and the delay time change in ppm. It is therefore desirable to use the minimum center frequency required to achieve the specified bandwidth.

Figure 2-10 shows the correlation peak loss (processing gain loss) as a function of temperature of 127-chip, 12.7 micro-second, 70-MHz center frequency-SWTDL-matched-filters-fabricated on different materials.

The SWTDL signal generator is maintained at +25°C and the SWTDL matched filter temperature is varied from -25°C to +95°C for each material. Since the phase shift versus temperature curve for ST-cut X propagation quartz is symmetrical about +25°C, any temperature difference between the SWTDL

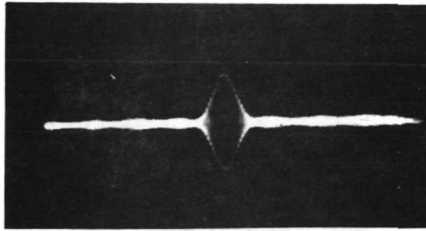

OUTPUT SIGNAL FROM QUARTZ (ROTATED  $-30^{\circ}$  Y CUT, X PROPAGATION) ENCODER – FILTER PAIR WHEN BOTH ARE AT SAME UNIFORM TEMPERATURE OF  $88^{\circ}\text{F}$ .

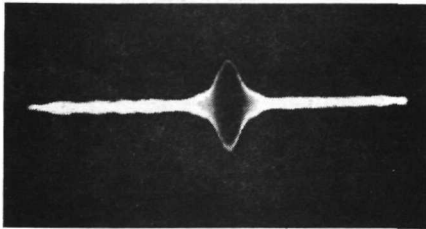

OUTPUT SIGNAL WHEN ENCODER IS AT  $88^{\circ}\text{F}$  AND FILTER AT  $184^{\circ}\text{F}$ .

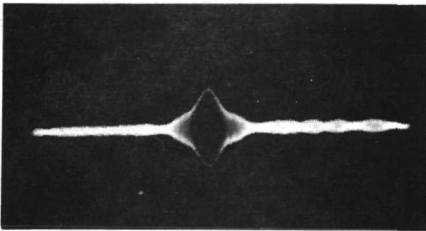

OUTPUT SIGNAL WHEN ENCODER IS AT  $88^{\circ}\text{F}$  AND FILTER AT  $238^{\circ}\text{F}$ .

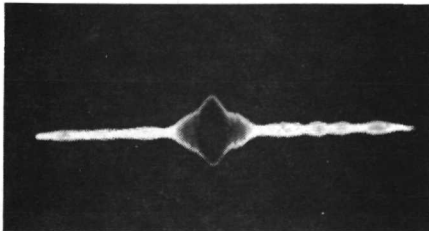

OUTPUT SIGNAL WHEN ENCODER IS AT  $88^{\circ}\text{F}$  AND FILTER AT  $280^{\circ}\text{F}$ .

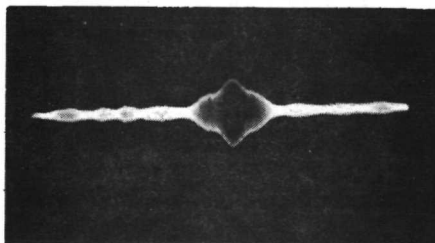

OUTPUT SIGNAL WHEN ENCODER IS AT  $88^{\circ}\text{F}$  AND FILTER AT  $+300^{\circ}\text{F}$ .

ASW-345-8

Figure 2-9. Autocorrelation Peak Degradations

signal generator and the SWTDL matched filter causes no degradation in correlation peak. For example, if the SWTDL signal generator is at 0°C and the matched filter is at +50°C little SWTDL processing gain loss will occur.

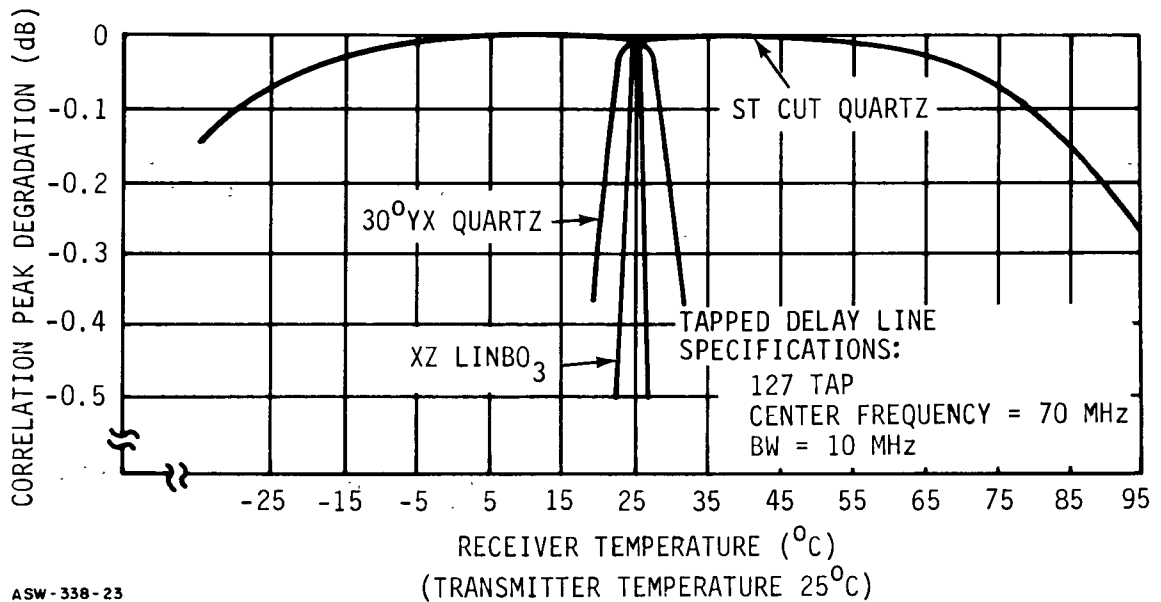

ASW-338-23

Figure 2-10. Correlation Peak Degradation Versus Temperature

(b) Doppler

The effect of doppler shift on a SWTDL matched filter is similar to the temperature difference effect. When excessive doppler shifts are introduced, correlation peak degradations similar to those shown in Figure 2-9 will be encountered.

2.3 Modulation/Demodulation Techniques

Use of SWTDL's in a communication system requires a means of transferring data to and from the spread spectrum signal generated on the acoustic devices. The methods by which this can be accomplished are discussed here.

A number of modulation/demodulation schemes utilizing SWTDL's are available. In general, these techniques are similar to modulation/demodulation schemes employed in other wideband (and narrowband) communications systems.

Analog modulation utilizing surface wave devices may take the form of Pulse Amplitude Modulation (PAM), Pulse Position Modulation (PPM), or Pulse Rate Modulation (PRM).

### 2.3.1 Pulse Amplitude Modulation (PAM)

Pulse amplitude modulation is accomplished by varying the amplitude of the pulse supplied to the encoding (transmitting) surface wave device as a function of the input data (see Figure 2-11). A PAM pulser excites the surface wave device with a pulse proportional to the modulating signal. The resultant spread spectrum impulse response of the surface wave device is thus amplitude modulated. When this amplitude modulated signal is supplied to a surface wave matched filter, the resultant correlation peaks derived from the matched filter are also amplitude modulated and this modulation is linearly related to the modulation of the transmitting surface wave device PAM pulser. A system such as this can be used for the transmission of either binary data or sampled analog data.

### 2.3.2 Pulse Position Modulation (PPM)

Pulse position modulation, (PPM), can be accomplished by simply varying the time position of the surface wave device excitation pulse in accordance with the input data. The time position of the resultant surface wave device impulse response relative to a reference time position thus varies in accordance with the input data. When these impulse responses are processed by a SWTDL matched filter, the correlation peaks produced by the matched filter vary in time position in the same manner as the encoding surface wave device excitation pulses. A system using this approach can be used for the transmission of binary or analog data.

### 2.3.3 Pulse Rate Modulation (PRM)

Pulse rate modulation (PRM), can be employed using surface wave devices by varying the pulse repetition rate supplied to the encoding surface wave device in accordance with the input data. When the resultant surface wave device output is processed by a surface wave matched filter, the correlation peaks have a pulse repetition rate identical to that of the excitation pulse repetition rate. A system using this approach can be used for the transmission of binary or analog data.

### 2.3.4 Phase Shift Keyed Modulation (PSK)

The transmission of digital information using surface wave devices is efficiently accomplished by using various forms of phase shift keying of the surface wave device excitation pulse. Before proceeding with this discussion, however, a clear distinction should be made between phase shift keying of the total surface wave device impulse response and phase shift keying within the surface wave device impulse response.

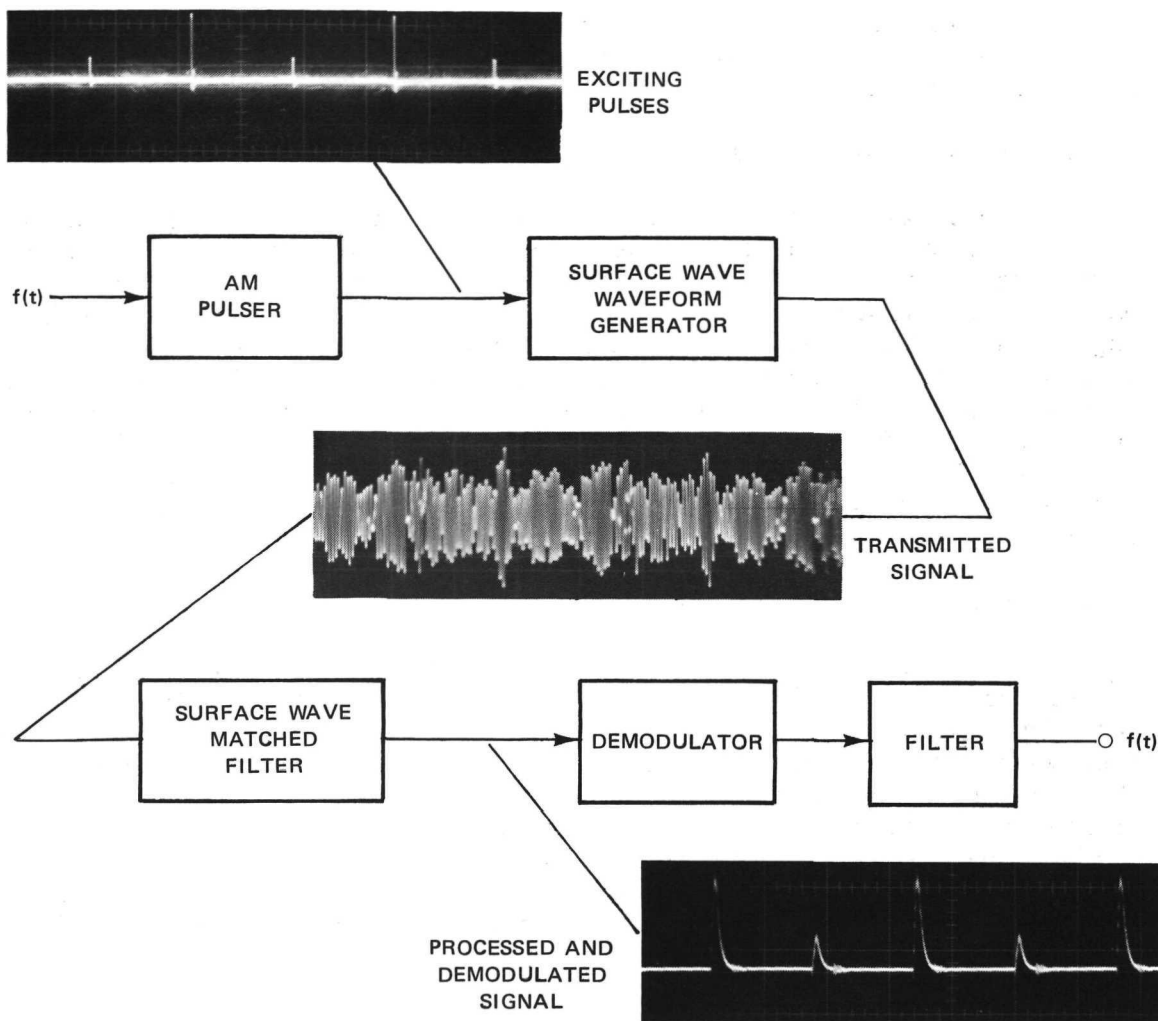

ASW-345-9

Figure 2-11. Pulse Amplitude Modulation

With a sequence of excitation pulses of one polarity, a train of impulse responses occurs with a corresponding polarity; and if the exciting pulse polarity reverses, the impulse response inverts.

The surface wave device impulse response is a phase shift keyed rf carrier. The impulse response has a finite duration and contains a finite number of phase shifts arranged in a fixed sequence. The sequence of phase shifts is determined by the design of the surface wave device output transducer. For a given excitation pulse polarity, the surface wave device impulse response, ie., the fixed sequence of phase shifts of the carrier, remains unchanged. If the polarity of the excitation pulse is changed (from a positive to a negative pulse for instance), the sequence of phase shifts of the carrier remains unchanged but the relative

phase of the carrier is changed 180 degrees. This is shown in Figure 2-12. Consider a surface wave device designed with the phase shift keyed impulse response sequence 1001011. The impulse response of the surface wave device for positive, and negative excitation pulses has the same sequence of carrier phase shifts but the carriers are 180 degrees out-of-phase with each other. When these carriers are processed in a surface wave device matched filter, they produce correlation peaks which have rf carriers that are 180 degrees out-of-phase with each other. Demodulation of the correlation peaks produce positive or negative pulses dependent upon the polarity of the transmitting surface wave device excitation pulse. This technique is further demonstrated in Figure 2-13 which shows oscillograms of the excitation pulses, impulse response, and demodulated correlation peaks of a 127-chip surface wave device PSK system. In this system, the period of the excitation pulses is equal to the length of the surface wave device impulse response so that the surface wave device output is a continuous waveform.

### 2.3.5 PSK Modulation Techniques

The communications system designer will be familiar with the various forms of PSK modulation used in conventional communications systems. These modulation techniques are also possible using surface wave devices; but in addition, several new PSK modulation techniques peculiar to surface wave technology are available. Several forms of PSK modulation utilizing surface wave devices have been investigated by The Magnavox Company.

- (a) Coherent Phase Shift Keying (CPSK)
- (b) Differentially Coherent Phase Shift Keying (DCPSK)
- (c) Double Pulse Method
- (d) Code Pair Phase Shift Keying (CPSK).

Coherent Phase Shift Keying (CPSK). - The signals employed in this modulation/demodulation technique are generated by controlling the polarity of the exciting pulse applied to the transmitting SWTDL, as previously discussed. The binary data directly controls the polarity of the exciting pulse and, therefore, directly controls the relative phase of each surface wave device impulse response. Referring to Figure 2-14, the phase shift keyed impulse responses produce correlation peaks at the surface wave device matched filter output. The relative phase of the autocorrelation peak rf carrier depends upon the relative phase of the transmitting SWTDL impulse response. Since the relative phase of the SWTDL impulse response is either zero or  $\pi$  radians, the relative phase of the autocorrelation peak rf carrier is zero or  $\pi$  radians. The zero or  $\pi$  radian phase shifts of the correlation peak carriers correspond directly to the baseband binary data.

Demodulation of the baseband data is accomplished by the following process. The correlation peaks are frequency multiplied by a factor of



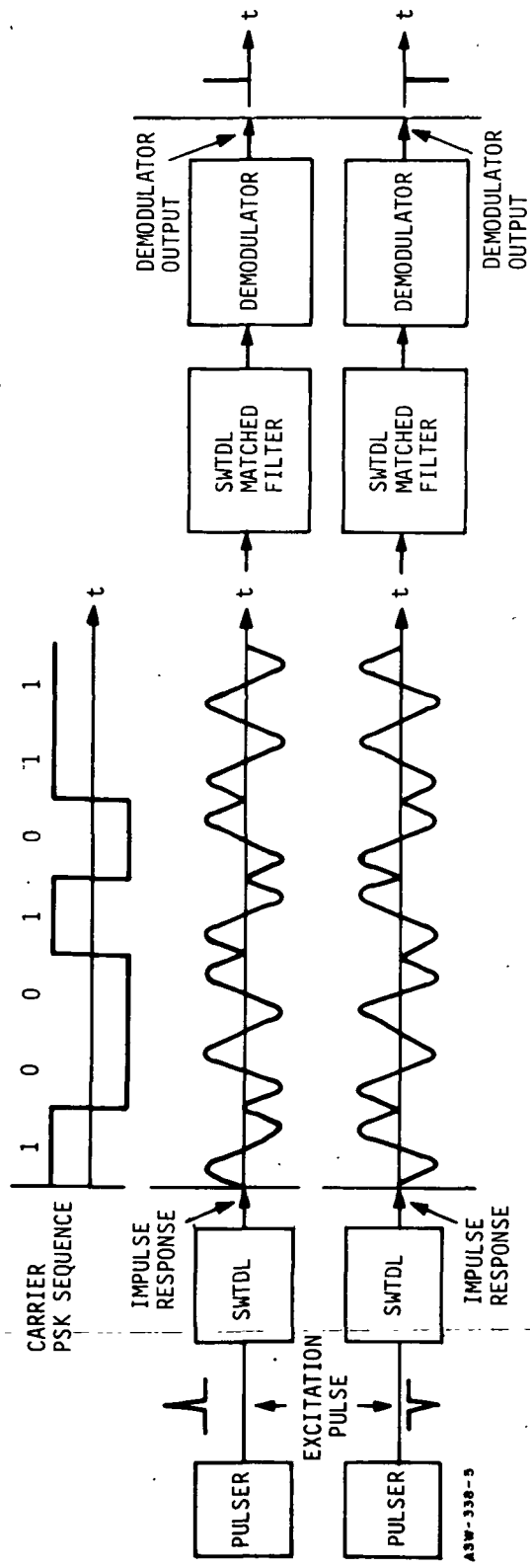
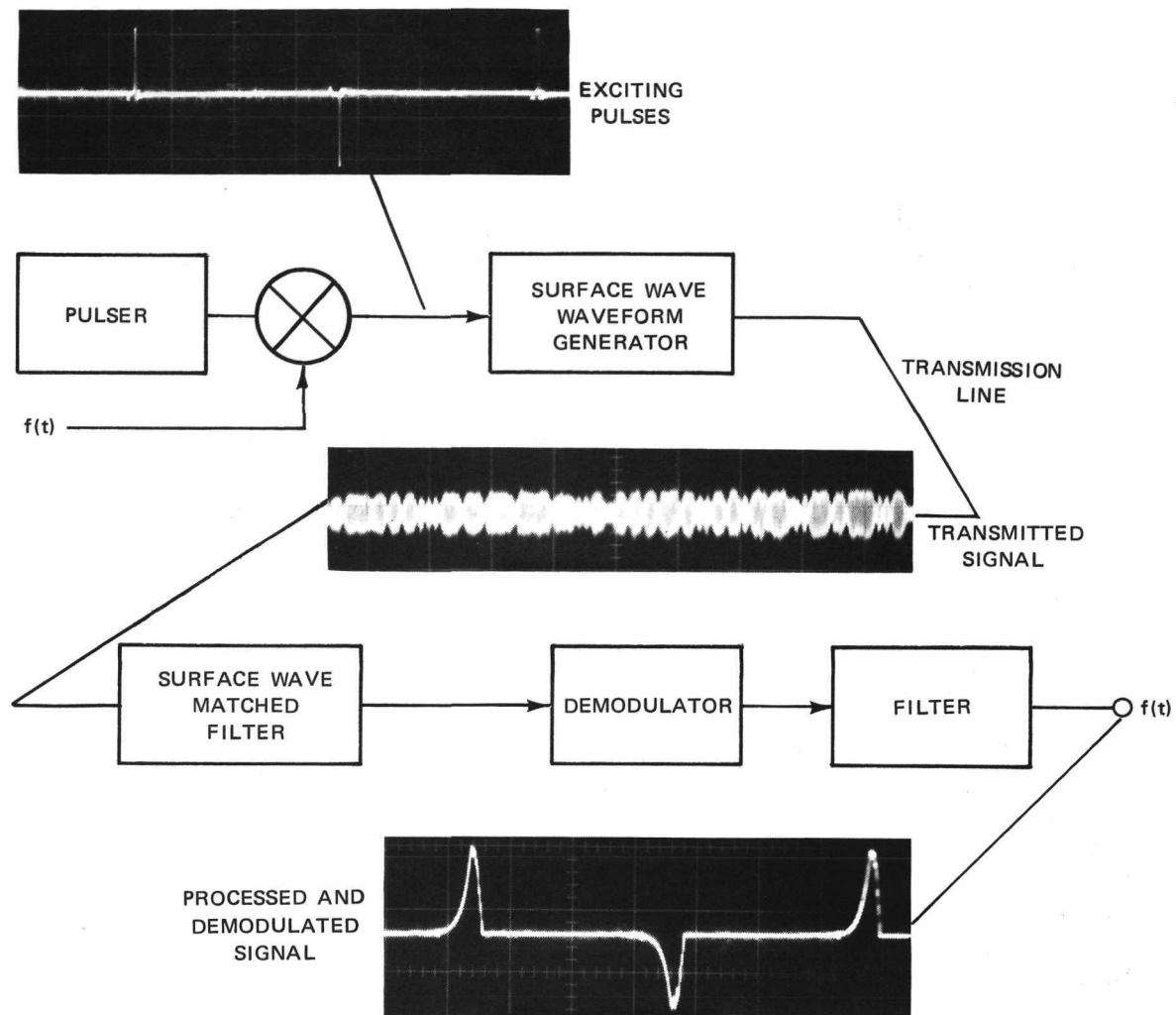

Figure 2-12. PSK Modulation of Surface Wave Device Impulse Response



ASW-345-10

Figure 2-13. Surface Wave Device Phase Shift Key Modulation

two. Thus the autocorrelation peak of carrier phase shifts of zero and  $\pi$  radians become phase shifts of zero and  $2\pi$  radians; and therefore, the output of the frequency and is phase continuous. A phase lock loop locks to the double frequency carrier and produces a coherent reference signal for the subsequent detection process. The phase lock loop VCO output is divided by two which results in a signal that is equal to the correlation peak carrier frequency and coherent with it. This signal and the correlation peaks from the surface wave matched filter are multiplied together and filtered in a baseband filter. The output of the baseband filter is a series of positive or negative pulses corresponding to the original binary modulation. These pulses are fed to a decision circuit which decides if a mark or space was demodulated and, thereby reconstructs the baseband data.

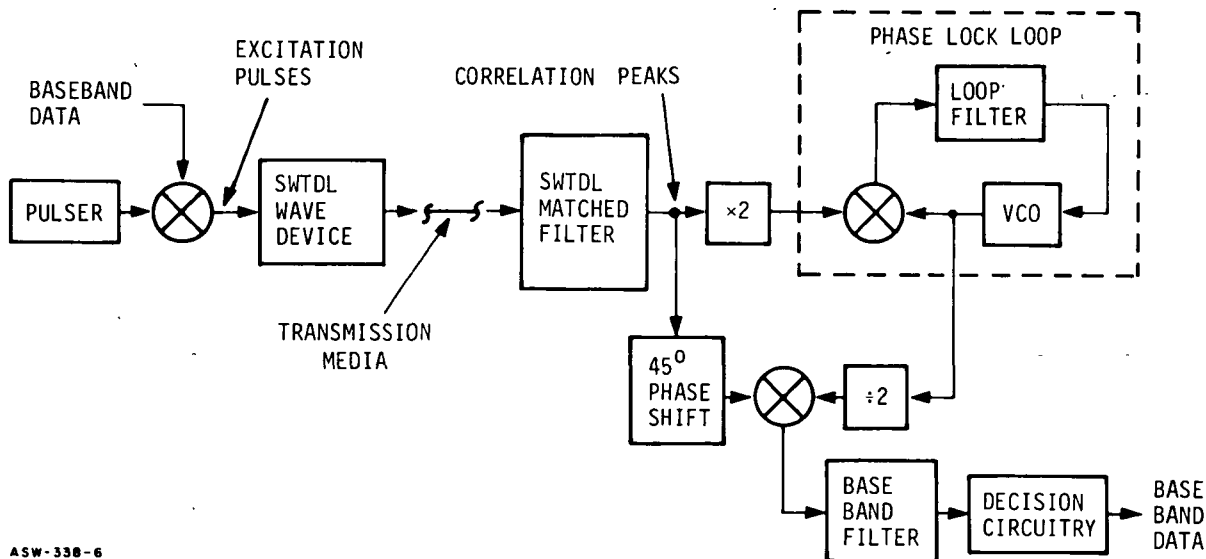

ASW-338-6

Figure 2-14. Coherent PSK Technique

Differentially Coherent Phase Shift Keying (DCPSK). - Differentially coherent PSK does not require the use a phase lock loop in the demodulation process and it is simpler to implement. In the modulation process, the binary data bit which controls the surface wave device excitation pulse polarity is differentially encoded in terms of the phase change between successive pulses. For example, an input data mark may be encoded as no change from the previous pulse polarity supplied to the surface wave device and an input data space encoded as a 180-degree change.

Referring to Figure 2-15, the output of the transmitting surface wave device would consist of differential PSK encoded impulse responses. These impulse responses, when processed by the surface wave device matched filter produce differential PSK encoded correlation pulses. The correlation pulses are delayed one bit time by a broadband delay line and multiplied by an undelayed version of the correlation pulses. The result of the multiplication is low pass filtered and fed to a decision circuit which makes a decision whether the data is a mark or a space and reconstructs the baseband data. Note that the multiplication process followed by the low pass filter approximates a coherent detection process since the correlation pulse is multiplied by a version of itself.

At all error rate levels, differentially coherent PSK requires a 3 dB higher signal-to-noise ratio than does ideal coherent PSK. Because of the exponential behavior of coherent detection, at high signal-to-noise ratios the differentially coherent PSK performs almost as well as ideal coherent detection. The prime implementation advantage of differentially coherent PSK modulation over ideal coherent PSK modulation in the elimination of the phase lock loop required for ideal coherent demodulation.

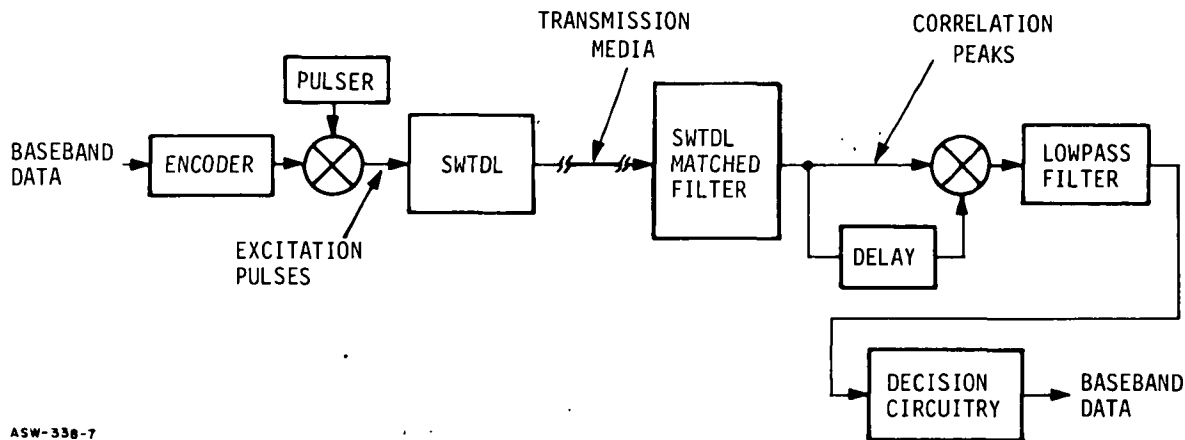

ASW-338-7

Figure 2-15. Differential Phase Shift Keying Technique

Double Pulse Method. - A PSK modulation technique developed by Magnavox to utilize the features of the SWTDL is the Double Pulse Method. To examine this scheme, refer to Figure 2-16. The transmitting SWTDL has two pairs of input transducers. One of the transducers is driven from a positive pulse while the second transducer is driven by a pulse that is polarity modulated by the baseband data. The two input transducers are separated by a fixed time surface wave delay established by the placement of the transducers on the SWTDL. The SWTDL output is a linear combination of the impulse responses produced by the first pulse and the delayed modulated pulse.

The surface wave matched filter also has a pair of output transducers separated by a delay of  $T_d$ . The output of the transmitting SWTDL is applied to the matched filter and two correlation peaks occur at each matched filter output transducer as shown in the oscillogram of Figure 2-16. Note that the last correlation peak from the first matched filter output transducer and the first correlation peak from the last matched filter output transducer occur simultaneously. The phase of the correlation peak carriers is determined by the polarity of the excitation pulses supplied to the transmitting surface wave device.

Both correlation peaks are applied to a balanced modulator which multiplies them together and provides the baseband data signal. However, the balanced modulator only provides an output when both matched filter output transducers have correlation peaks occurring simultaneously. If both excitation pulses supplied to the input transducers of the transmitting surface wave device are positive, as they are when the baseband data is positive, the phase of the simultaneously occurring correlation peaks are the same and the resultant baseband signal from the balanced modulator is positive. However, when the baseband data is negative, the rf carrier of the correlation peaks from the surface wave

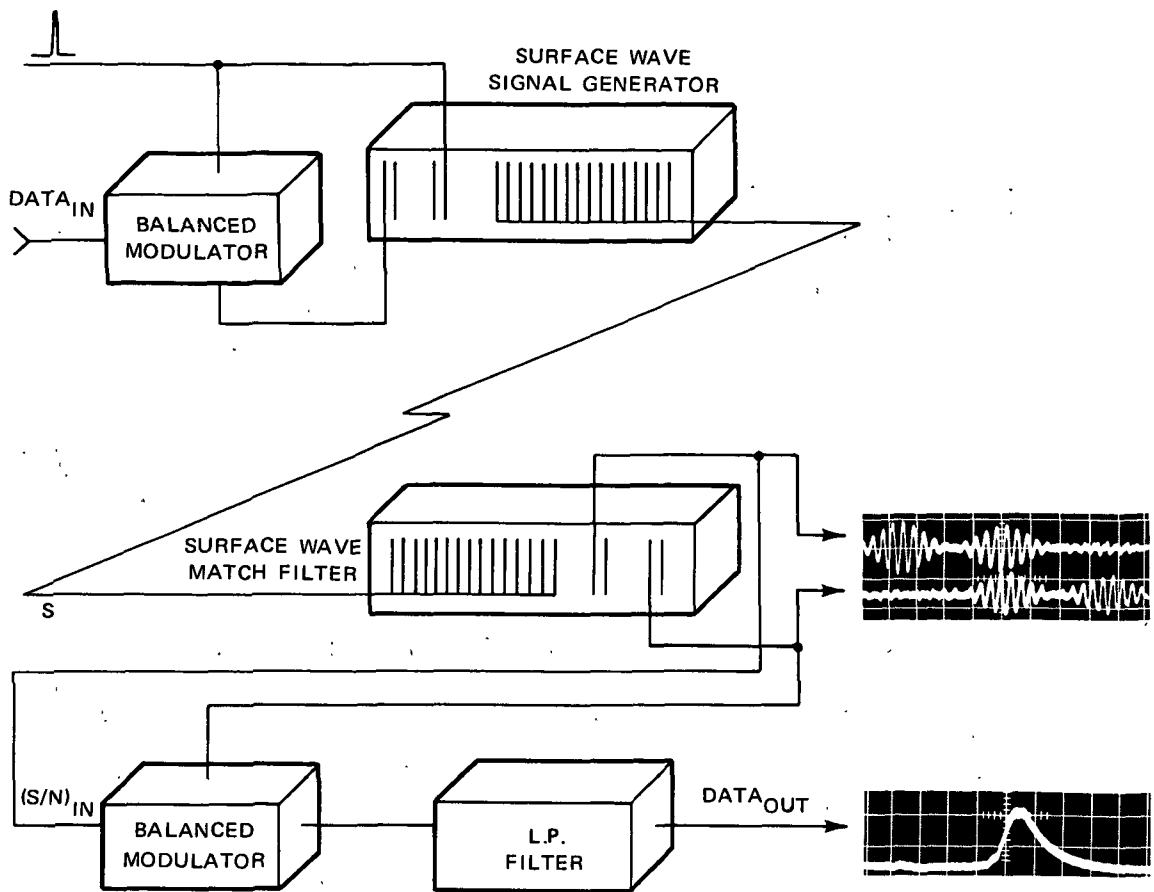

ASW-338-25

Figure 2-16. Double Pulse Mode Phase Shift Keying Technique

matched filter are 180 degrees out of phase (i.e., opposite in polarity) and the baseband output the balanced modulator is negative.

Like differentially coherent PSK, this system does not require a reconstructed carrier (i.e., phase lock loop). The necessary signal delays in both the transmitting surface wave device and the SWTDL matched filter are incorporated on the devices themselves which makes the implementation of the double pulse mode technique somewhat simpler than the differentially coherent PSK technique. Signal-to-noise performance of the double pulse mode is 3 dB below that of differentially coherent PSK for high signal-to-noise ratios but is notably degraded compared to differentially coherent PSK for signal-to-noise ratios below zero dB. A comparison of signal-to-noise ratio performance of coherent PSK, differentially coherent PSK, and double pulse mode PSK is shown graphically in Section 4.0, Figure 4-14.

Code Pair Phase Shift Keying (CPPSK). - Another phase shift modulation technique developed by the Magnavox Company to utilize the features

of SWTDL's is Code Pair Phase Shift Keying. This modulation scheme is illustrated in Figure 2-17. At the transmitter end of the communications link, two SWTDL's are used to generate the spread spectrum signals. The SWTDL's have identical center frequencies, bandwidths, and chip lengths but their impulse responses produce different PN code sequences. The PN code sequences at the SWTDL's are chosen to have good, (i.e., minimal), cross correlations.

Modulation of the spread spectrum signal is performed by supplying one of the SWTDL's (see device A in Figure 2-17) with a constant polarity excitation pulse. SWTDL device B is excited with a pulse whose polarity is determined by the baseband data. The outputs of devices A and B are summed to produce the transmitted spread spectrum signal.

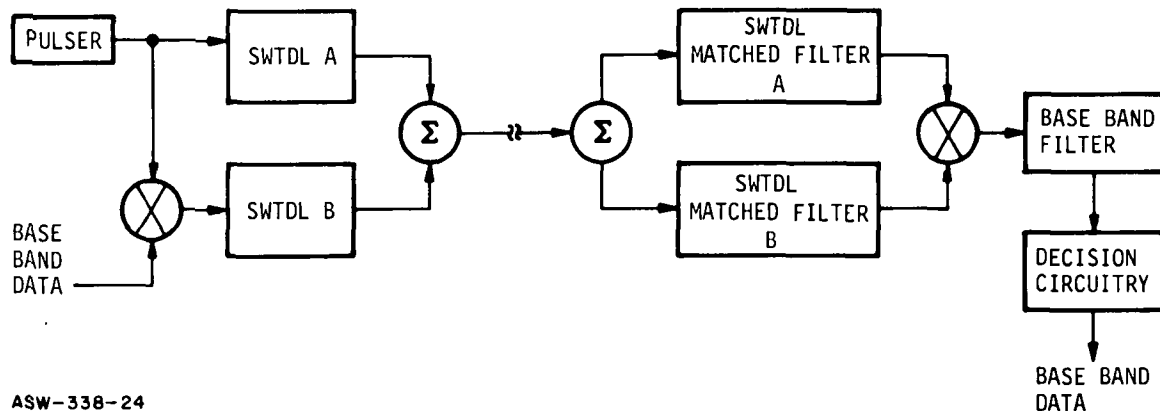

ASW-338-24

Figure 2-17. Code Pair Phase Shift Keying Technique

At the receiver end of the communications link, the spread spectrum signal is applied to SWTDL matched filters A and B simultaneously. SWTDL matched filter A is the matched filter for transmitter SWTDL A. Likewise, SWTDL matched filter B is the matched filter to transmitter SWTDL B.

The correlation peaks produced at the SWTDL matched filter outputs are multiplied in a balanced mixer. The carrier frequencies of the two correlation peaks are identical, but the relative phase of the carriers is dependent upon the relative polarity of transmitting SWTDL excitation pulses. Thus, if the excitation pulses have the same polarity, the correlation peak carriers are in phase; and if the excitation pulses are of opposite polarity the correlation peak carriers are 180 degrees out-of-phase.

When the correlation peaks are multiplied by the balanced mixer and filtered by the baseband filter they produce pulses whose polarity

is dependent upon the relative phase of the correlation peak carriers; and hence, they are ultimately dependent upon the baseband data at the transmitter end of the link. A decision circuit samples the pulses and reconstructs the baseband data.

Code Pair PSK, like the double pulse method is an attractive modulation technique since it does not require the generation of a reconstructed carrier by means of a phase lock loop at the receiver. Signal-to-noise performance is identical to that of the double pulse technique. However, for application to the spread spectrum command system concept, the CPPSK technique has an advantage over double pulse method because it exhibits superior jamming signal rejection characteristics. With properly chosen SWTDL code pairs, the line structure superimposed on the  $\left(\frac{\sin x}{x}\right)^2$  power spectrum of one code will not coincide with the line structure superimposed on the other code power spectrum; and thus, the code pair spread spectrum signal is less susceptible (than a double pulse mode spectrum) to narrowband jamming signals. Simultaneous time cross correlations of properly chosen code pair signals with multiuser or intentional jamming signals are less likely than cross correlations of a double pulse mode technique code with jamming signals so wideband jamming signal rejection of the code pair modulation technique is superior to the double pulse modulation technique.

### 2.3.6 Comparison Of PSK Modulation Techniques

A comparison of the four PSK modulation techniques, relative to the operating requirements of the Spread Spectrum Command System, indicates that Code Pair PSK is the best choice as a modulation technique. Implementation requirements, detection efficiency, and RFI rejection characteristics of the various techniques are compared in Table 2-2 below.

TABLE 2-2. CHARACTERISTICS OF MODULATION TECHNIQUES

| Modulation                          | Implementation Requirements       | Detection Efficiency          | RFI Rejection | Laboratory Demonstrated Using Surface Wave Devices |
|-------------------------------------|-----------------------------------|-------------------------------|---------------|--|
| Coherent PSK (CPSK)                 | complex, requires phase lock loop | optimum                       | good          | Yes  |
| Differentially Coherent PSK (DCPSK) | complex for TDMA format           | 3 dB below optimum            | good          | Yes  |
| Pulse Pair PSK (PPPSK)              | simple                            | 3 dB below DCPSK for high S/N | good          | Yes  |
| Code Pair PSK (CPPSK)               | simple                            |                               | excellent     | Yes  |

Implementation of the CPSK technique is complex because CPSK requires a phase lock loop for demodulation. The DCPSK technique requires a fairly precise time delay element to provide a bit time delay for the demodulation process. Since in the TDMA format the period between transmitted data bits is varied in a PN sequence, implementation of the DCPSK technique tends to be somewhat complex because of the required variable bit time delay.

Detection efficiency of the CPPSK technique is only 3 dB below that of DCPSK for high signal-to-noise ratios and the interference rejection provided by the CPPSK technique is superior to that of the other modulation techniques. Since the CPPSK technique employs two different SWTDL matched filters rather than the single SWTDL matched filter used by the other techniques, there is less chance of interfering signals getting through both matched filters simultaneously and contaminating the detection process.

#### 2.4 Programmable Surface Wave Tapped Delay Line

The SWTDL's discussed previous to this report have been fixed devices whose tap configurations are set during fabrication. The usefulness of these devices can be extended considerably by implementing them in such a way that the tap polarities can be controlled with electrical signals. In such a case, the impulse response of a SWTDL is electronically variable and multiple code wideband systems can be implemented with a single, programmable device, being used as a matched filter.

##### 2.4.1 Breadboard Version

For example, in a code multiplex system using surface wave devices, each receiving station must be capable of recognizing any of the codes it wishes to monitor. The station can use separate fixed code devices, one for each code of interest. The output of each device would then be directed to the appropriate terminal device for use as desired. For a station monitoring a large number of channels, the number of devices required can become impractically large. An alternative to this is to use electronically programmed devices which can be switched to respond to the desired codes. If the receiver is not required to simultaneously monitor all of the channels, it can employ fewer devices, with each device being electronically programmed to match the code needed at any instant.

Figure 2-18 shows a breadboard version of a programmable SWTDL built in the Magnavox laboratories. This experimental device is constructed using a 13-tap delay line with p-i-n diode switches to provide polarity control.

Figure 2-19 is a schematic of the p-i-n diode polarity switch. The rf resistance of p-i-n diodes decreases with increasing dc diode



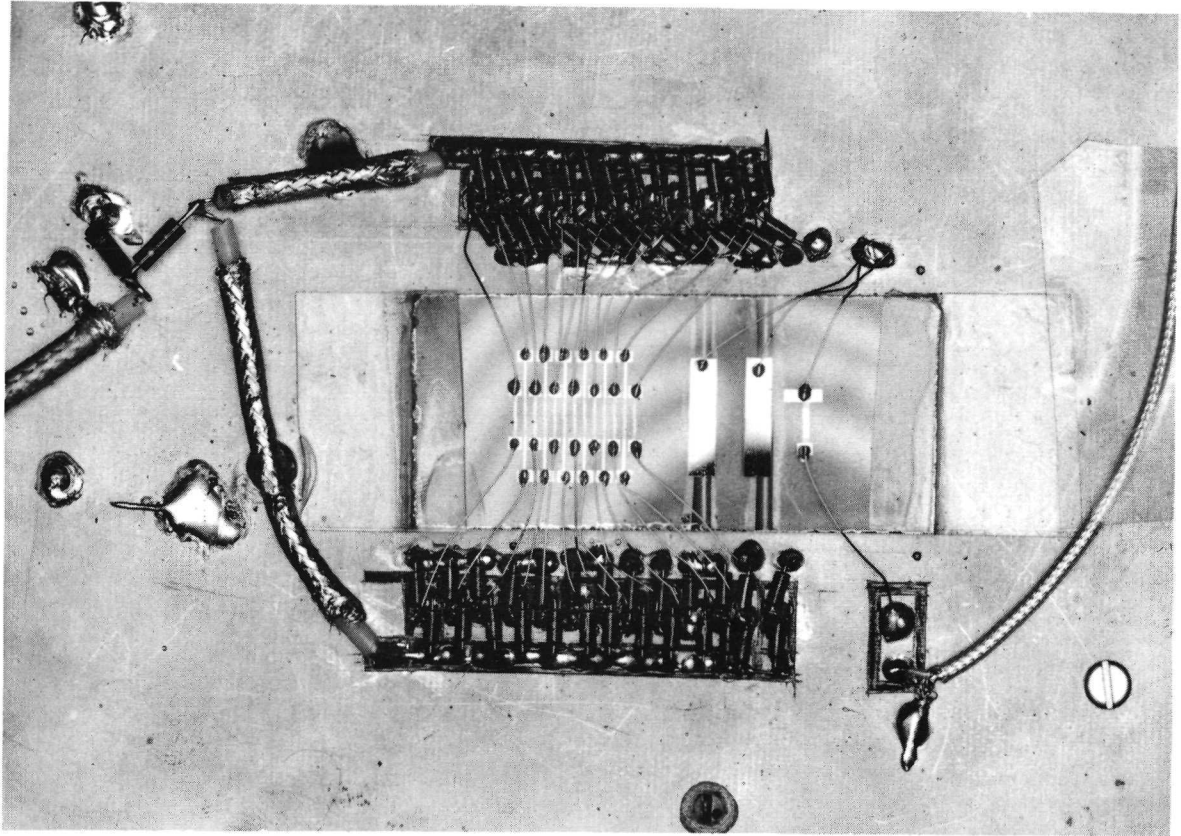

ASW-345-1

Figure 2-18. Programmable SWTDL (Breadboard Version)

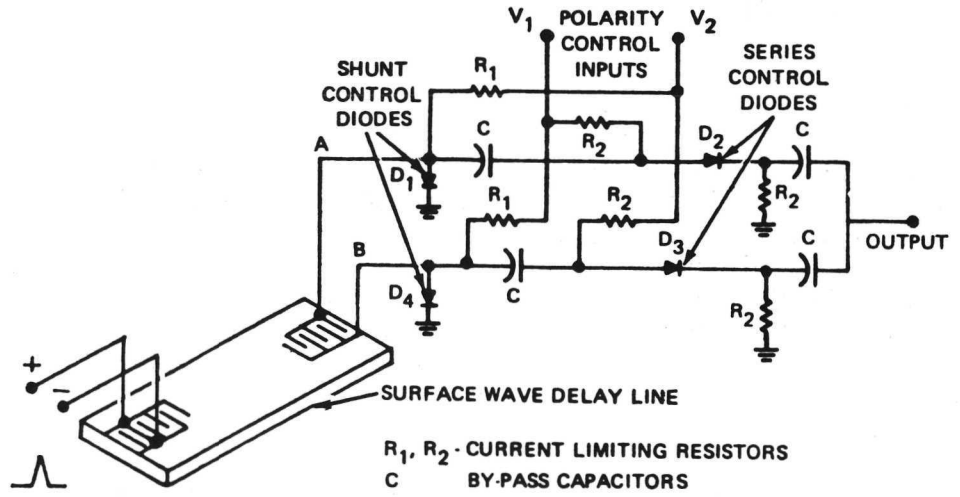

ASW-345-2

Figure 2-19. A p-i-n Diode Polarity Switch for a Delay-Line Tap

current ( $I_{dc}$ ). The upper resistance limit ( $I_{dc} = 0$ ) for the diodes used is approximately 7000 ohms. The application of 3 mA dc current causes the resistance to drop to 10 ohms. The dc diode current level is determined by the dc control voltage and the current limiting resistors. For normal tap polarity, control input  $V_1$  has a positive voltage and control input  $V_2$  has a ground potential. In this state, diodes  $D_2$  and  $D_3$  is high. This ground point B through a low impedance while isolating point A from ground and connecting it to the output terminal. The polarity is reversed by interchanging the voltage at the control inputs.

A detailed equivalent circuit of the switch in the normal polarity state is shown in Figure 2-20a. With approximations, the polarity switched 35-MHz delay-line tap equivalent circuit can be reduced to that in Figure 2-20b. Well-designed SWTDL's have transducer reactions exceeding several hundred ohms. With transducer impedances of this magnitude, the equivalent circuit in Figure 2-20b very closely approximates a simple hardwired transducer tap. The programmable interdigital transducers can be summed and matched just like hardwired fixed-code transducers.

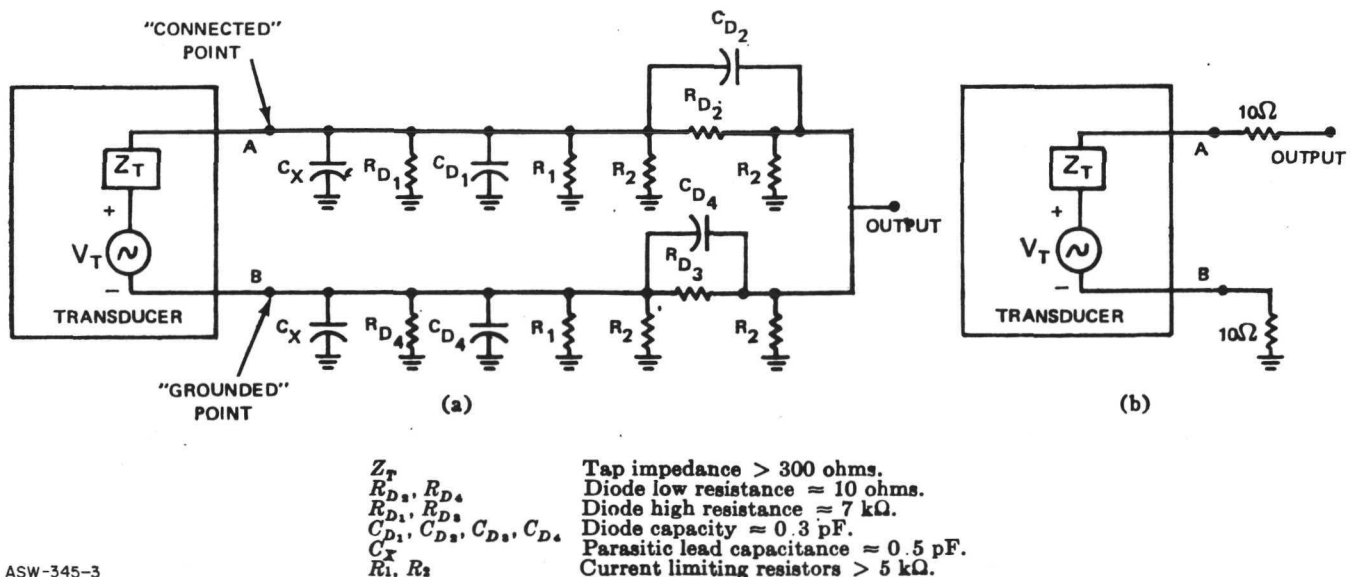
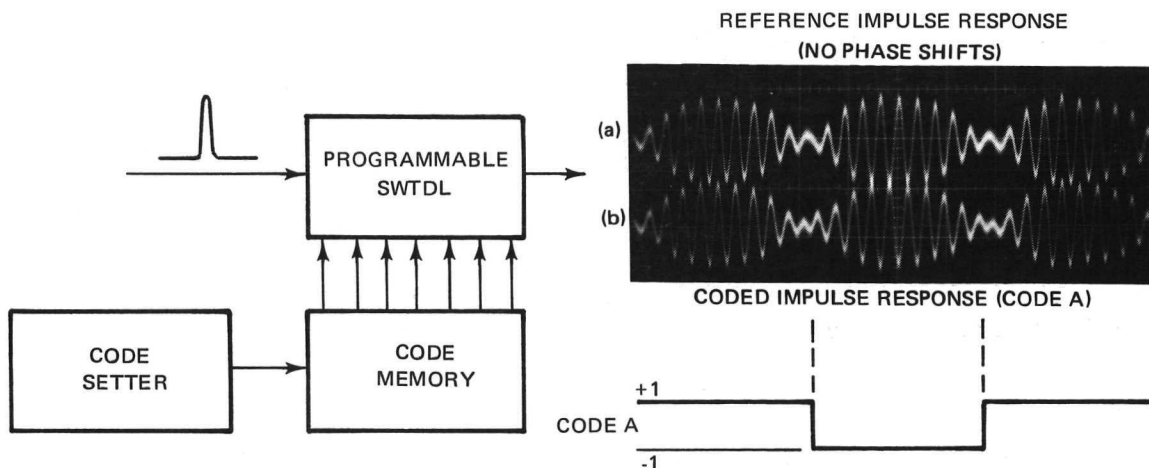

Figure 2-20. Tap Polarity Switch in Normal Polarity State:  
 (a) Detailed Equivalent Circuit (b) Simplified  
 Equivalent Circuit

#### 2.4.2 Experimental Results

The waveforms shown in Figure 2-21 were obtained using the bread-board device shown in Figure 2-18. Each pulse group is the output voltage



ASW-345-4

Figure 2-21. Impulse Response Oscillograms

appearing at one of the taps. Trace (a), in Figure 2-21, shows the output obtained by summing three taps; trace (b) shows the output of the same taps with the polarity of one tap electronically changed. To permit better visual interpretation of the waveform, the output transducer geometry was arranged so as to cause amplitude modulation in the observed impulse response. In a final device, a constant envelope PSK signal would ordinarily be produced. Observe the 180-degree phase shift in the center of the photograph corresponding to the second bit of Code A.

Figure 2-22 shows waveforms obtained by using two programmable devices. The top two photographs, (a) and (b), show the sequence generator outputs for two different codes (A and B). In this case, the second code is constructed as the reverse of the first. The other five waveforms, (c) through (g), result when the sequence generator is applied to a programmable matched filter of similar design. Strong autocorrelation peaks occur in traces (c) and (e) because both the sequence generator and the matched filter have the same codes. Traces (d) and (f) show the results obtained when the sequence generator is programmed for one code and the matched filter is programmed for the reverse of that code. In trace (g), both devices have the same code except that one bit error is programmed into the matched filter. Note the partial correlation obtained with the one bit error and the attendant increase in sidelobes.

The polarity switches and only a small amount of series resistance to the transducer impedance, and little additional insertion loss results. The polarity switched multitap transducer can be matched with a single matching network and the tap output summation is achieved by simply connecting the switch outputs to a common output terminal pair.

Only diodes and resistors are used in the polarity switch design, and either thick film or thin film fabrication techniques may be used.

The switches are only moderately affected by different transducer impedances; therefore, the same switch configuration is used for almost any transducer design.

The switching rate for this type of programmable line can be varied from dc to one MHz and the number of switchable taps feasible with microelectronic techniques is in excess of 500.

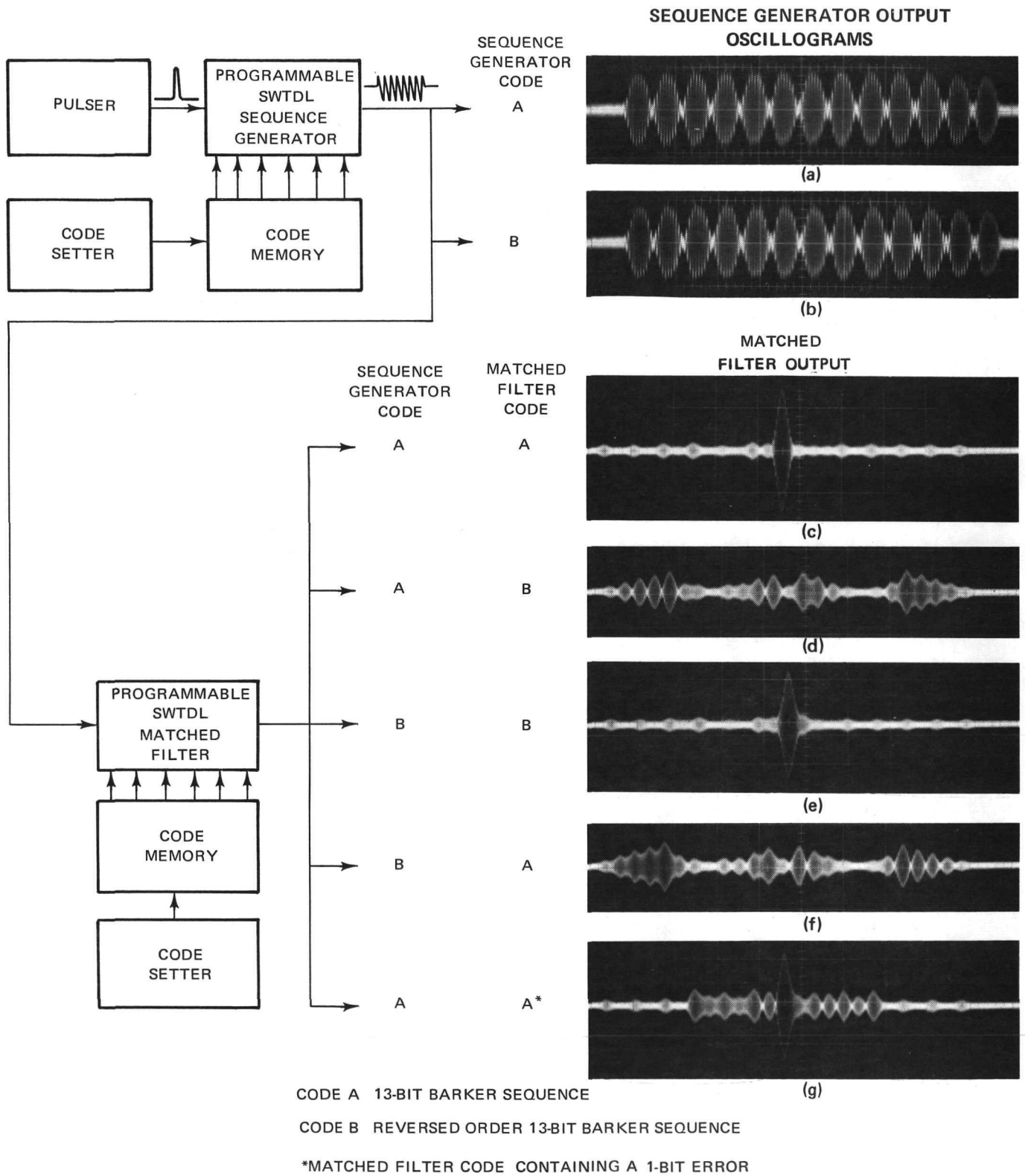

Figure 2-22. Signal Recognition with Programmable SWTDL

ASW-345-5

### 3.0 SELECTED APPLICATIONS OF SURFACE WAVE TECHNOLOGY

This section describes a few selected applications of surface wave technology. The applications reported herein are typical communication system type uses for SWTDL's and are presented to help identify potential application areas for these devices.

#### 3.1 Spread Spectrum Transceiver

For the purpose of illustrating one application of surface wave signal processors, Magnavox has fabricated two spread spectrum transceivers utilizing surface wave signal processors to generate a spread spectrum rf signal and to recompress the spectrum on reception. These devices are shown in Figure 3-1.

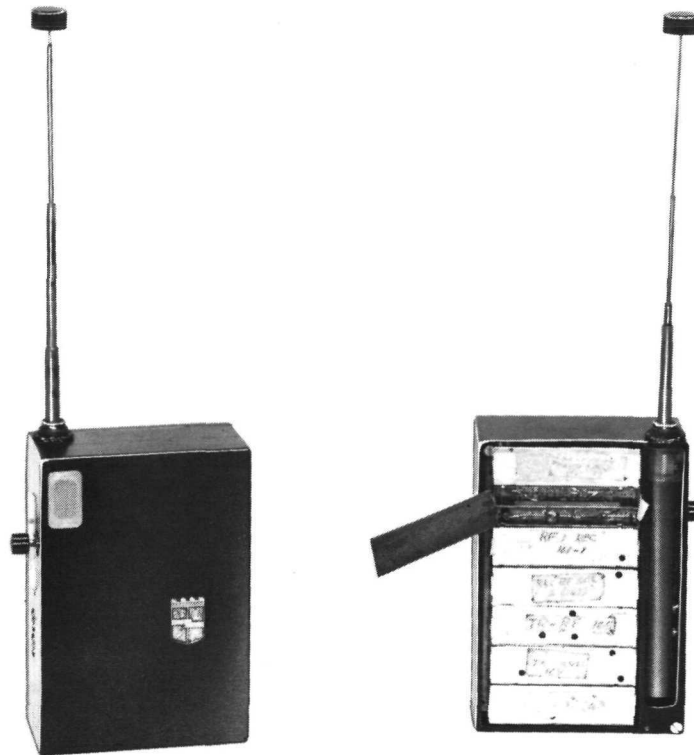

ASW-298-21

Figure 3-1. Spread Spectrum Transceivers

These transceivers are based on acoustic surface wave multiple tapped delay lines. Figure 3-2 is a schematic diagram of a generalized tapped delay line. It is shown that if  $x(t)$  is the input to the tapped

line and  $a_n$  is the relative weight of the nth tap the output  $e_o(t)$  becomes

$$e_o(t) = \sum_{n=1}^N a_n x(t - \tau_n)$$

where  $\tau_n$  is the delay associated with the nth tap.

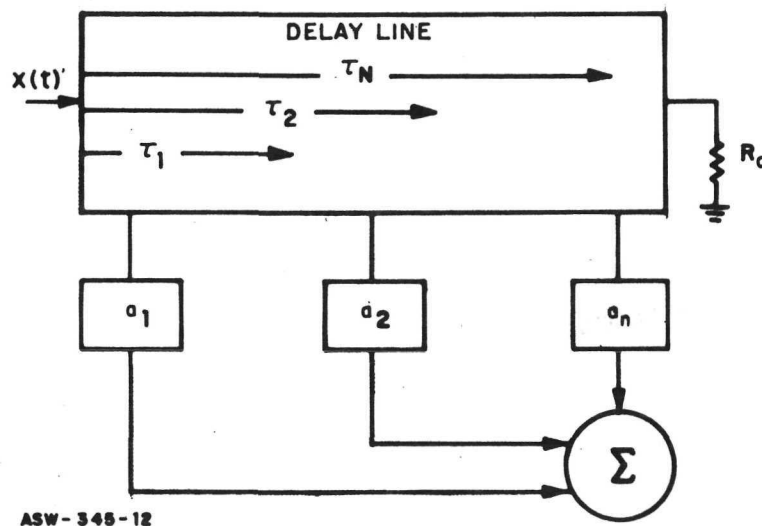

Figure 3-2. Diagram of a Generalized Tapped Delay Line

If the input function  $x(t)$  is a periodic series of short pulses with a low duty cycle representing sampled data, it is possible, through the appropriate choice of  $a_n$ , to generate a spread spectrum signal. With  $a_n$  chosen to be either +1 or -1 in accordance with one of the linear maximal pseudorandom sequences, and with  $\tau_n = nT$  (where  $T$  is the delay per tap), a phase shift keyed sinusoidal spread spectrum wave form is generated.

On the surface wave device, the required phase inversions are accomplished by reversing the alternation pattern of the conductor pairs. If the points of reversal are located in accordance with a pseudorandom code, a phase coded wave form is generated.

The spread spectrum signal can also be decoded by a second tapped delay line. This is accomplished by using the spread spectrum output

as the input to the second line. The output of the second line is

$$f(t) = \sum_{m=1}^N b_m e_o(t - mT)$$

If  $b_m$  is selected to be the exact reverse of  $a_n$ , i.e.,  $b_m = a_1$ ,  $b_{m-1} = a_2$ , etc; then the generalized device in Figure 3-2 yields the autocorrelation function of the sequence  $a_n$ . Thus, the spread spectrum input is properly decoded by the second delay line.

Using surface wave techniques, the decoding correlator is a second SWTDL identical to the encoding line but arranged so that the time-spread surface wave signal traverses the code pattern in the reverse direction (required by the autocorrelation process). A correlation pulse obtained in this manner is shown in Figure 3-3. A more complete discussion of SWTDL's is found in Section 2.0 of this report.

The experimental transceivers shown in Figure 3-1 were fabricated using surface wave processors and other microelectronic components to illustrate the applicability of the surface wave correlation technique to miniaturized equipment.

Figure 3-4 is a schematic representation of the operational transceiver. A voice signal from the microphone is amplified and fed into the voltage-controlled pulser, which then produces a frequency modulated pulse train. With this input, the surface wave correlator output is approximately a continuous 40-MHz PSK signal with a 4-MHz bandwidth. When received by a conventional AM/FM receiver, this noise-like signal cannot be interpreted. The phase shifts are determined by the output grids, which in this case are fabricated to produce a 13-bit Barker sequence. The rf amplifier boosts the power level for antenna radiation. In the receiver circuit, the antenna and the 50-ohm matching network feed a signal to the rf amplifier and gain control circuitry. Gain limiting for the AGC action is achieved by a diode detector and amplifier controlling a PIN diode attenuator. The receiver front end thus presents a constant amplitude signal to the surface wave correlator. This noise-like signal is applied to the surface wave decoder, which is designed as a matched filter for the received signal. The receiver-decoder discriminates against noise and converts the continuous envelope rf signal into a series of autocorrelation pulses -- one for every pulse which energized the encoding surface wave correlator. The decoder pulses are amplified and decoded by a phase locked discriminator. Through use of an appropriate low pass filter, the original voice modulation is recovered from the VCO control voltage. There is no superheterodyne circuitry; direct baseband voice signals are derived from the detected and filtered autocorrelation pulses. During field tests, the hand held transceiver was observed to maintain a clear and distinct voice communication to a range of 1/4 mile. Detectability tests were conducted with a standard fm monitor receiver which was tunable over the transceiver



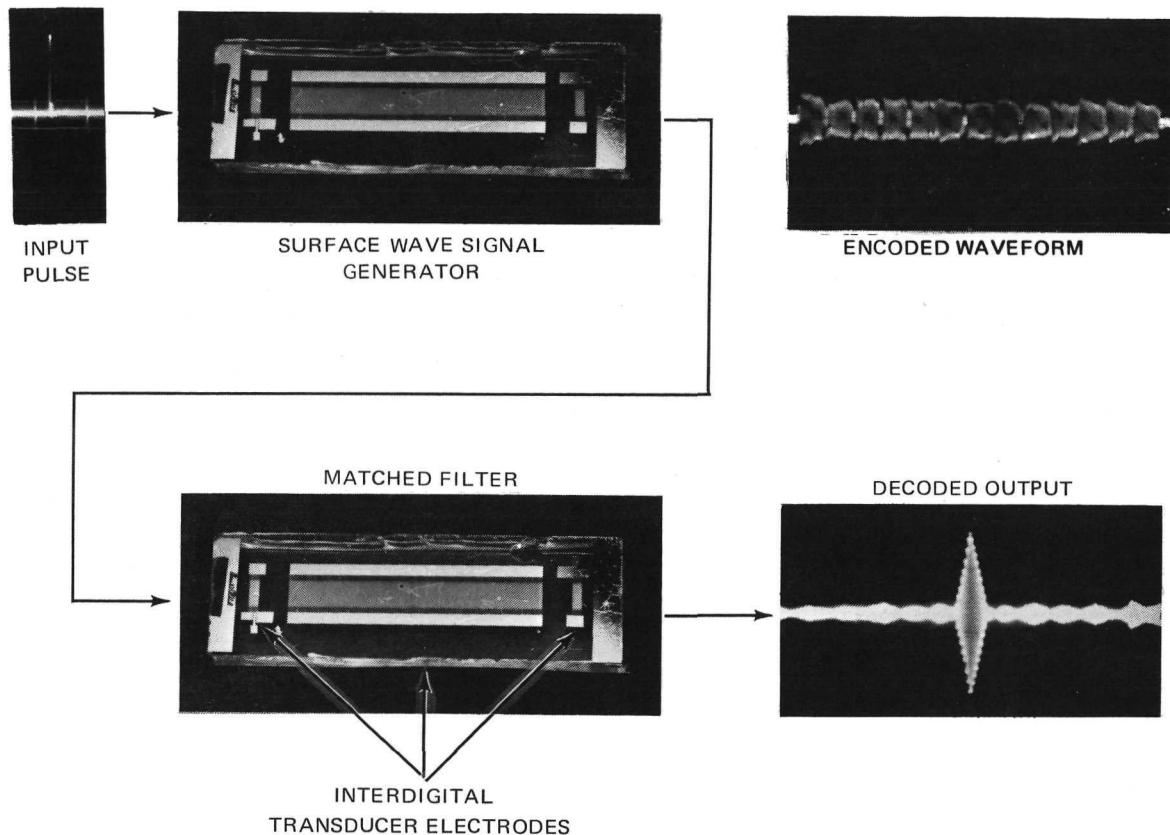

ASW-345-11

Figure 3-3. Experimental Transceivers Using SWTDL's

operating spectrum. In no case was the monitor able to produce intelligible speech from the transceiver signal. Processing gain of the encoder-decoder system using a 13 bit Barker code is plotted in Figure 3-5.

With such a system, the need for special pseudonoise generators, local oscillators, sync-search/lockup circuitry, carrier tracking loops, and the like is avoided. This enables reliable, low cost, and compact private spread spectrum links to be realized with many of the features of more complex systems.

### 3.2 Acoustic Surface Wave Modem\*

The size of a SWTDL is a limiting factor in terms of code length for spread spectrum signal generation and matched filter detection applications, but this difficulty is avoided when a reentry delay line is used to coherently add several consecutive correlation peaks. This accomplishes a linear summation over an interval corresponding to several input pulses to the SWTDL encoder, extending the effective code length (time bandwidth

-----  
 \* This system was developed under contract NAS 5-20198

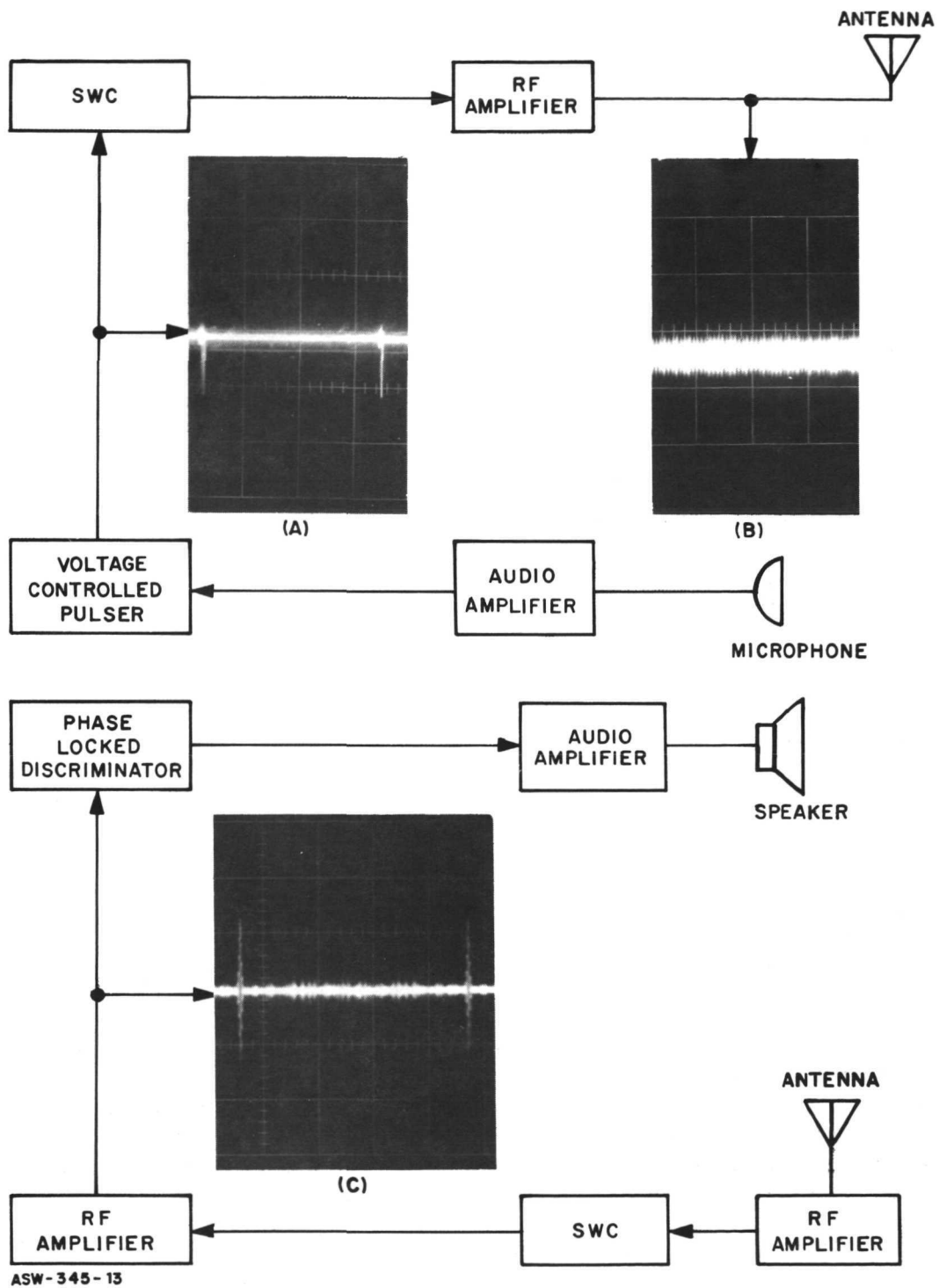

Figure 3-4. Low Detectability Transceiver, Block Diagram

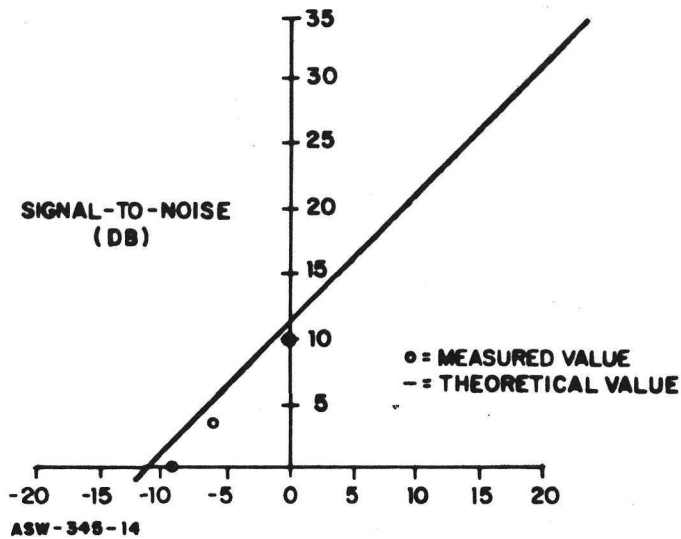

Figure 3-5. Graph Showing Encoder-Decoder Processing Gain

product) in proportion to the number of iterations in the reentry delay line. The concept of modern implementation is illustrated in Figure 3-6.

The PN sequence generator in the modulator serially encodes the input data stream, spreading the spectrum of the baseband signal by producing in each data bit interval a sequence of narrow pulses of changing polarity. The encoded baseband pulse stream is applied to a SWTDL which further encodes the signal in accordance with the pattern of the interdigital conductors comprising the output transducer.

The output transducer is designed in such a way that each narrow input pulse generates a long PN encoded pulse at the desired center frequency (IF). When the input pulse repetition period equals the duration of the surface wave device output pulse, a constant envelope spread spectrum IF signal results.

In the demodulator, the spread spectrum signal is first processed by a SWTDL matched filter like that used in the modulator, and a periodic sequence of correlation peaks results. The repetition rate of the correlation peaks corresponds to the repetition rate of the pulse generator used in the modulator, and the phase in each depends upon both the PN generator used in the modulator and the data signal.

The matched filter output is applied to a serial decoder along with the output from a synchronized sequence generator like the one used in the transmitter. Another sequence of constant amplitude correlation peaks appears at the output of the serial decoder, but now the phase of the IF carrier in the correlation peaks is determined solely by the data being conveyed.

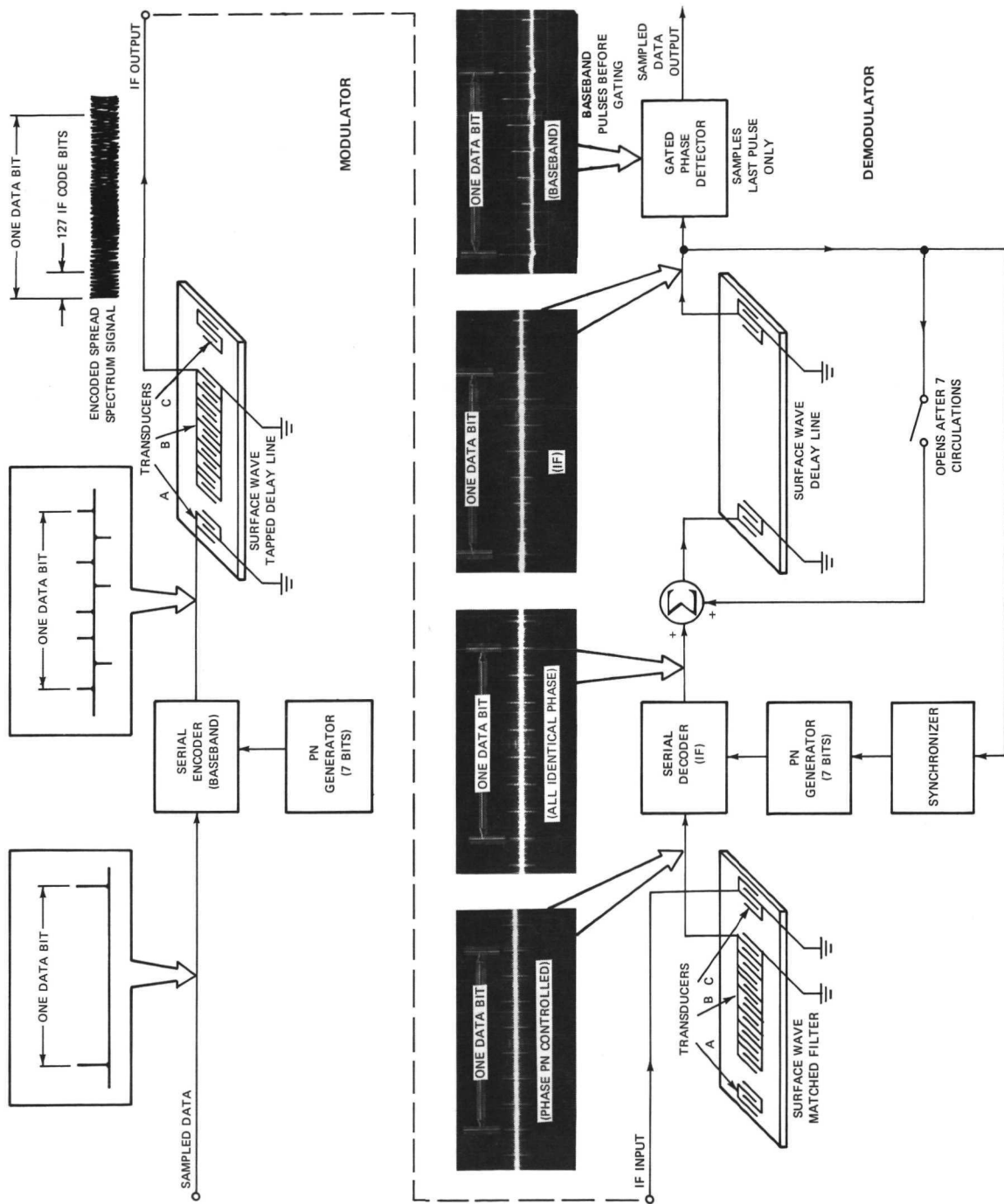

ASW-345-15

Figure 3-6. Concept of Modem Implementation

These correlation peaks are applied to a reentry surface wave delay line, and the delay line output grows linearly in amplitude as each input correlation peak adds directly in phase with the signal recirculated from the delay line output. A phase detector senses the phase of the carrier, yielding a sequence of baseband pulses with amplitudes corresponding to those at the delay line output. (The polarity of the baseband pulses is determined by the data; they build in the positive direction for a data "1", negative for a "0".)

The largest peak is sampled and applied to the demodulator output, and simultaneously the delay line is "dumped" in preparation for the next coherent pulse buildup. The dump command is forced to coincide in time with the data intervals.

Although positive feedback is used in the recirculating loop, no stability problem occurs because the line is dumped intermittently. Furthermore, no significant loss in processing gain occurs when the closed loop gain is between 0.85 and 1.05.

### 3.2.1 Transmitter Operation

An expanded block diagram of the transmitter breadboard version is shown in Figure 3-7 and its signal timing diagram is shown in Figure 3-8.

The transmitter is composed of four basic parts: a sequence generator, a pulser, a 127-tap SWTDL signal generator, and a power amplifier. Its output is a continuous envelope, 32-MHz rf signal modulated by an 8-MHz PN code. In the timing diagram, it can be seen that the polarity of the pulses out of the pulse shaper follows the logic state of the seven-bit sequence generator is the digitized data is a logical "1" and its inverse if the data is "0". Each pulse causes a 127-bit PN PSK spread spectrum signal to be generated at the output of the SWTDL signal generator; the phase of the signal is determined by the polarity of the initiating pulses. Each data bit is composed of seven pulses, and the effective spread spectrum code length per data bit is 889 (7 x 127).<sup>\*</sup> Data clock pulses occur at the end of each 889-bit segment and at the trailing edge of the pulse clocks in the next input data bit.

The 64-kHz clock derived from the reference oscillator spaces the pulses at intervals precisely equal to the time required for the surface wave to propagate from the first to the last tap (i.e., the time corresponding to 127 bits). The transmitted signal is essentially continuous, with pulse-to-pulse phase discontinuity determined by the short-term

---

<sup>\*</sup>The breadboard lines will use eight pulses per data bit to achieve an effective code length of 1016. Seven pulses per data bit were used in the bench model because the required seven-bit PN generator was readily available and adequately demonstrates the principle. The description is based on seven pulses per bit instead of eight so that it will track the data and oscillograms taken in the bench model.

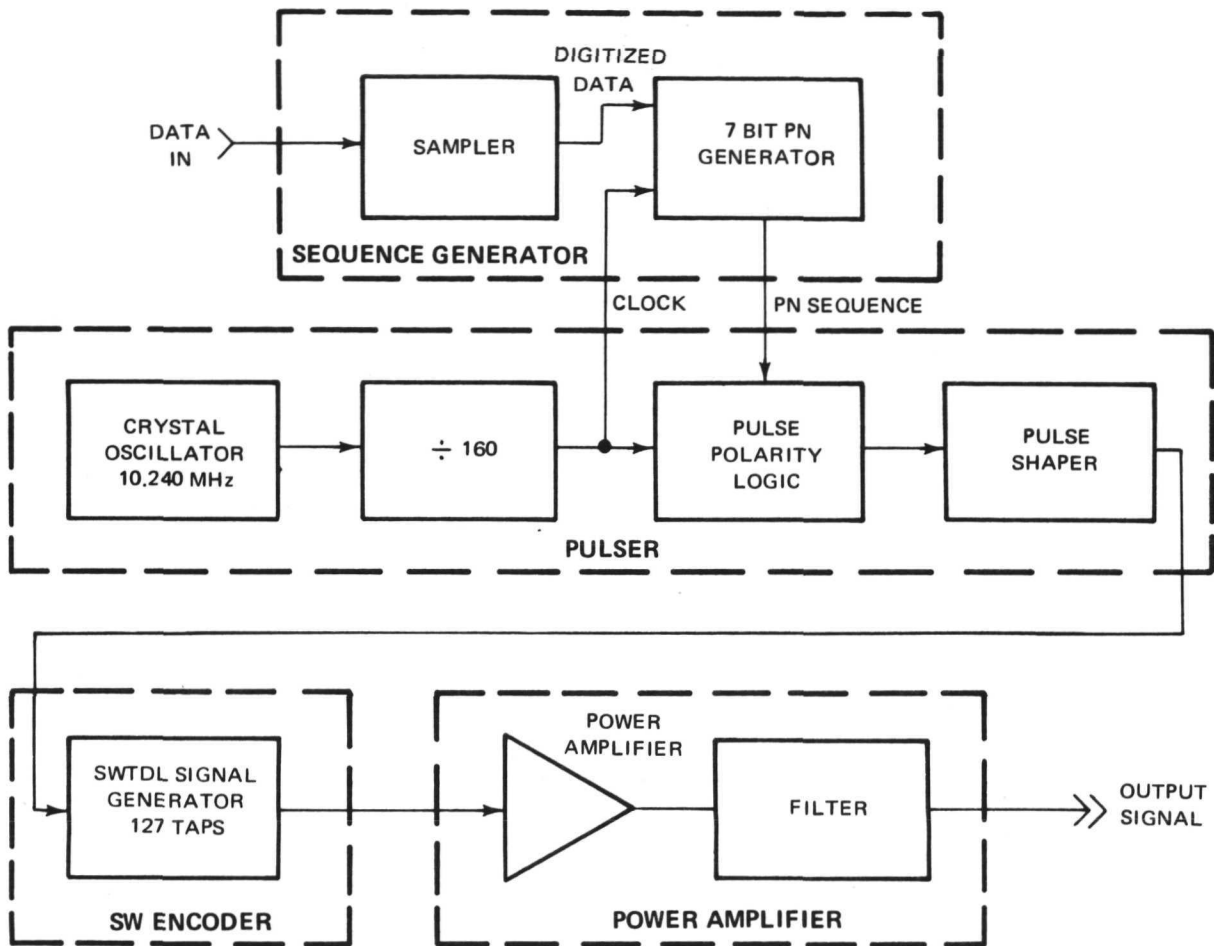

ASW-345-16

Figure 3-7. Transmitter (Coherent PSK Mode)

stability of the reference crystal oscillator. A short-term stability of  $\pm 1 \times 10^{-7}$  is sufficient for proper operation of the receiver phase-lock loops; this is well within the limits of off-the-shelf crystal oscillators.

The positive and negative impulses from the pulse shaper (5 V, 10 ns wide) initiate the spread spectrum signal generated by the SWTDL signal generator. This signal is linearly amplified and band-limited before transmission.

### 3.2.2 Receiver Operation

An expanded block diagram of the receiver and its associated timing diagram are shown in Figures 3-9 and 3-10, respectively. The timing diagram of the transmitter's input data, data clock, and sequence generator are included for comparison. Optimal processing of the transmitted spread

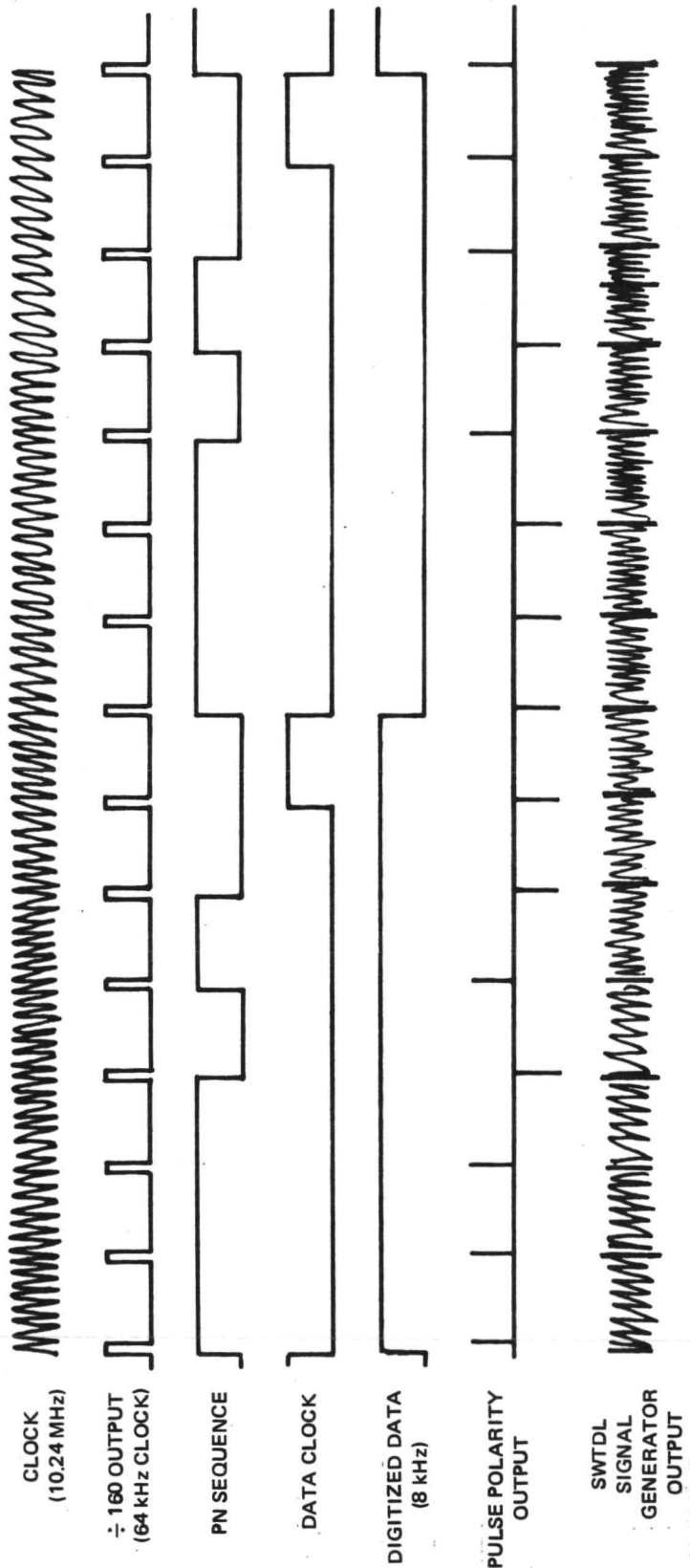

Figure 3-8. Timing Diagram of DRSS Transmitter

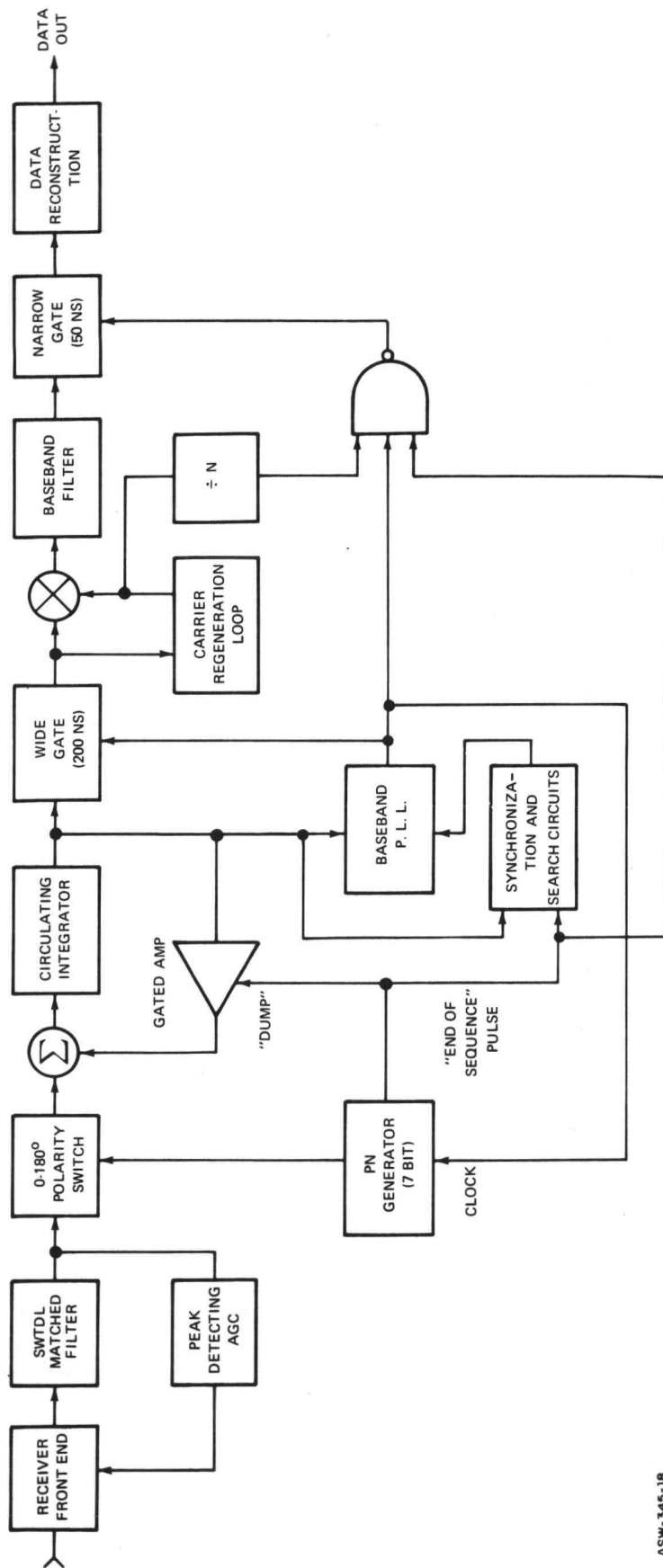

Figure 3-9. Receiver (Coherent PSK Mode)

ASW-345-18



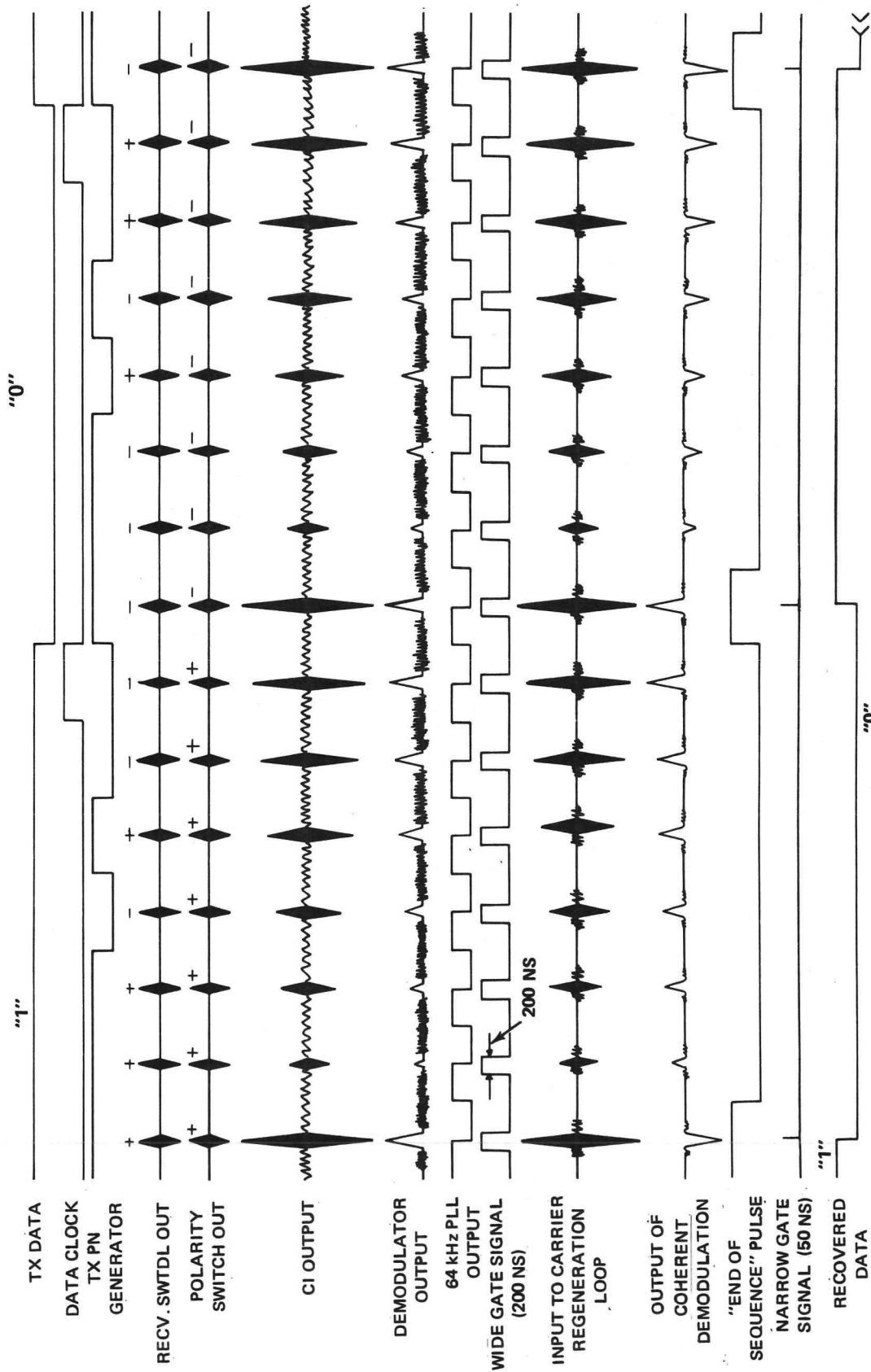

Figure 3-10. Timing Diagram of DRSS Receiver

spectrum signal is accomplished at the receiver through use of two surface wave devices: a SWTDL matched filter which converts the receiver signal into a series of rf pulses, and a reentry delay line (circulating integrator) which coherently integrates successive correlation peaks.

Following reception, the spread spectrum signal is amplified and applied to the SWTDL matched filter for decoding. Since the surface wave device is identical to the transmitter's SWTDL generator, the received signal is convoluted with its own reverse time argument yielding a series of autocorrelation peaks; the phase polarity of the latter alternates in accordance with the transmitter's sequence generator output. A peak detection AGC circuit derived from the correlation peaks envelope will be used to control receiver gain. This circuit takes advantage of the 20 dB improvement in S/N due to the processing gain of the matched filters for generating the AGC control voltage.

Once synchronization has been achieved, the seven-bit sequence generator (identical to the one used in the transmitter) operating with the polarity switch de-scrambles the code pattern so that all correlation peaks with a data bit have the same phase polarity. It should be noted that when the data changes from a "1" to a "0", the phase polarity of the correlation peaks switches 180 degrees.

The circulating integrator provides additional S/N improvement by coherently adding the seven correlation peaks corresponding to a data bit. These peaks add linearly with each circulation while the noise adds quadratically, resulting in a  $10 \log n$  improvement in S/N ( $n$  = number of circulations).

For seven circulations, this improvement corresponds to 8.5 dB. The 127-bit SWTDL matched filter and circulating integrator act together as a correlation matched filter with an effective code length of 889 bits.

A wide gate circuit (200 ns wide) at the circulating integrator output passes only correlation peaks while deleting a large portion of the total noise power. The gate is controlled by the 64-kHz baseband PLL (phase-lock loop), which is phase locked to the envelope detected correlation peaks from the circulating integrator.

The carrier regeneration loop reconstructs a phase-locked continuous carrier from the rf portion of the correlation peaks out of the wide gate. The individual correlation peaks are subsequently product-detected, with this regenerated carrier yielding a series of positive and negative baseband pulses.

A final narrow gate signal (50 ns wide) is derived from countdown circuits off the carrier regeneration loop. This gate samples the coherently demodulated envelope of the seventh correlation peak to determine whether a logic "1" or "0" has been transmitted. The data reconstruction circuit is a first order hold circuit which holds the sampled narrow gate

information as a logical "1" or "0" depending on whether the voltage was positive or negative. This recovered digital data is the receiver output which lags the transmitted data by one data bit time ( $\approx 109.2 \mu\text{s}$ ).

During the seventh circulation in the circulating integrator, an end-of-sequence pulse is generated in the sequence generator which opens the circulating integrator feedback path and subsequently provides proper framing for the narrow gate signal.

Synchronization with the seven-bit sequence generator of the transmitter's is checked every seven bits; if the system drops lock because of fading or noise, it immediately reverts to the search mode. Upon reacquiring lock, the baseband PLL locks to the correlation peak envelope and is used as the synchronous clock for the sequence generator. In the search mode, the baseband PLL operates at 64.12 kHz (120 Hz higher than the pulse repetition rate in the transmitter) and sweeps the receiver sequence generator phase relative to the transmitted sequence generator. At this search rate, the worst case lock-up time is 50 ms.

### 3.2.3 Alternate Method of Operation

This modem is also capable of operating using the double pulse modulation technique described in Sections 2.0 and 4.0.

In this mode of operation, the transmitted signal is a superposition of two signals. The two signals are delayed relative to each other, and have the same phase if the data input is a logic "1" and opposite phases if the data input is a logic "0". The transmitter is the same as previously described except that two pulses, instead of one, are applied to the SWTDL signal generator during each 15-microsecond interval.

In the receiver, the signals are processed and separated by the SWTDL and the circulating integrator. The circulating integrator is fitted with an extra set of taps so that the separated signals can be accessed and multiplied together. If the data input at the transmitter is a logic "1", both signals out of the circulating integrator will have the same phase and a positive baseband signal will result from the multiplier. If the data into the transmitter is a logic "0", the two outputs out of the circulating integrator will have opposite phases and the resulting baseband output signal will be negative. The receiver is the same as previously described except that the need for a carrier reconstruction loop is removed and the circulating integrator has an extra set of taps to access the individual signals.

### 3.2.4 Operational Data

The results tabulated in Table 3-1 were obtained in the described breadboard system.

TABLE 3-1. BREADBOARD OPERATIONAL DATA

| Characteristic                    | Data           |
|-----------------------------------|----------------|
| IF CENTER FREQUENCY               | 32 MHz         |
| BANDWIDTH                         | 8.001 MHz      |
| TAPPED DELAY LINE                 | 127 TAPS       |
| CIRCULATING INTEGRATOR            | 7 CIRCULATIONS |
| TOTAL CODE LENGTH                 | 889 BITS       |
| DATA BIT RATE                     | 9,000/SECOND   |
| S/N IMPROVEMENT BY MATCHED FILTER | 19.8 dB        |
| S/N IMPROVEMENT BY RECIRCULATION  | 7.8 dB         |
| TOTAL S/N IMPROVEMENT             | 27.6 dB        |
| RECEIVER ACQUISITION TIME         | 0.1 SECOND     |

### 3.3 Code Multiplex Transceiver

This subsection discusses the application of another spread-spectrum modulation technique which becomes feasible with SWTDL's. This technique has been investigated specifically for a multiple channel, code multiplex, wideband transceiver, and is discussed in terms of a transceiver. The basic technique, however, has a more general applicability.

#### 3.3.1 Basic Concept

In the basic concept, two SWTDL's are pulsed in the transmitter (see Figure 3-11) which produces two different coded spread spectrum rf signals. These two pulses occur with a small time difference (several nanoseconds), the exact difference being a function of the audio signal to be transmitted. The two signals are linearly combined prior to transmission. The duration of each transmitter SWTDL output pulse is approximately 8.5  $\mu$ s and the repetition rate is about 6 kHz, yielding a duty cycle near five percent for the specific system under discussion.

Two SWTDL matched filters are required in the receiver to demodulate the signal. One is designed to detect the component of signal generated by one of the transmitter SWTDL's, and the second is designed to detect that of the other transmitter SWTDL. Each matched filter output contains a pulse of rf signal with a narrow triangular envelope (correlation peak) in response to the signal for which it was designed, along with a noise-like rf signal of considerably smaller amplitude than the peak. Outputs of the two matched filter SWTDL's are multiplied together to recover the transmitted information.

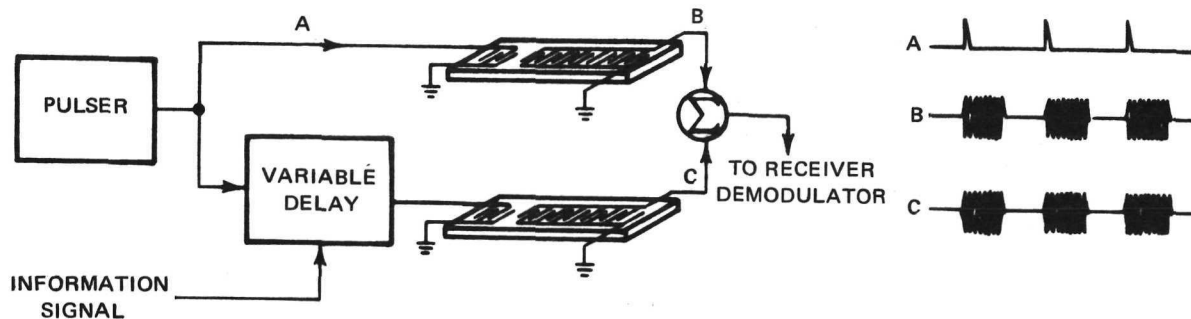

a) TRANSMITTER MODULATOR

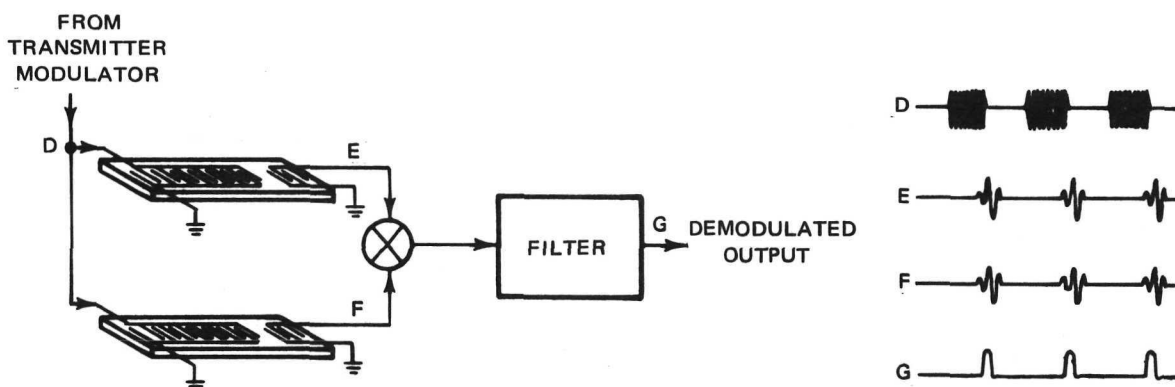

ASW-345-20

b) RECEIVER DEMODULATOR

Figure 3-11. Basic Concept of a Code Multiplex Transceiver

The multiplier output is small when the noise-like signal is present, but it is substantial when both correlation peaks occur. Then it is proportional to the cosine of the phase angle between the rf signals comprising the two peaks. The phase between the two correlation peaks depends upon the time relationship of the transmitter initiating pulses, i.e., it is controlled by the information signal. The peak voltage at the multiplier output then contains the transmitted information.

If one component of the received signal matches a receiver SWTDL but the other component doesn't, only one correlation peak occurs. The output of the other receiver SWTDL produces a noise-like signal and no peak will occur in the multiplier output. The same is true if neither component of the received signal is correct, and this characteristic is the basis for this technique for code multiplexing.

In Figure 3-11, only two SWTDL's are shown, and only a single address capability exists. If several SWTDL's, each coded differently, are provided in both the receiver and the transmitter, it is possible

to provide many channels by selecting a different code pair for each discrete address.

Normally, a modulator like that described above would be fabricated to produce a spread spectrum output signal centered at 100 MHz or less. This signal can be translated to a higher frequency prior to transmission if desired. At the receiver, the signal would then be down converted before it is applied to the demodulator.

Figure 3-12a is a block diagram of such a spread spectrum communication link using this modulation approach. In the transmitter, the audio signal is amplified and applied to the surface wave encoder and signal generating assembly where it is used to modulate pulses which drive the surface wave devices. The surface wave devices produce a 15-MHz bandwidth spread spectrum signal centered at 70 MHz which is translated to a 370-MHz center frequency and transmitted.

Figure 3-12b shows the receiver block diagram. The rf signal is amplified, translated down to 70 MHz, and applied to the surface wave matched filter detector circuitry. When the correct receiver channel selection is made, the receiver surface wave devices act as matched filter detectors for the transmitted signal, discriminating against both CW and wideband interference, including that generated by transmitters with other addresses.

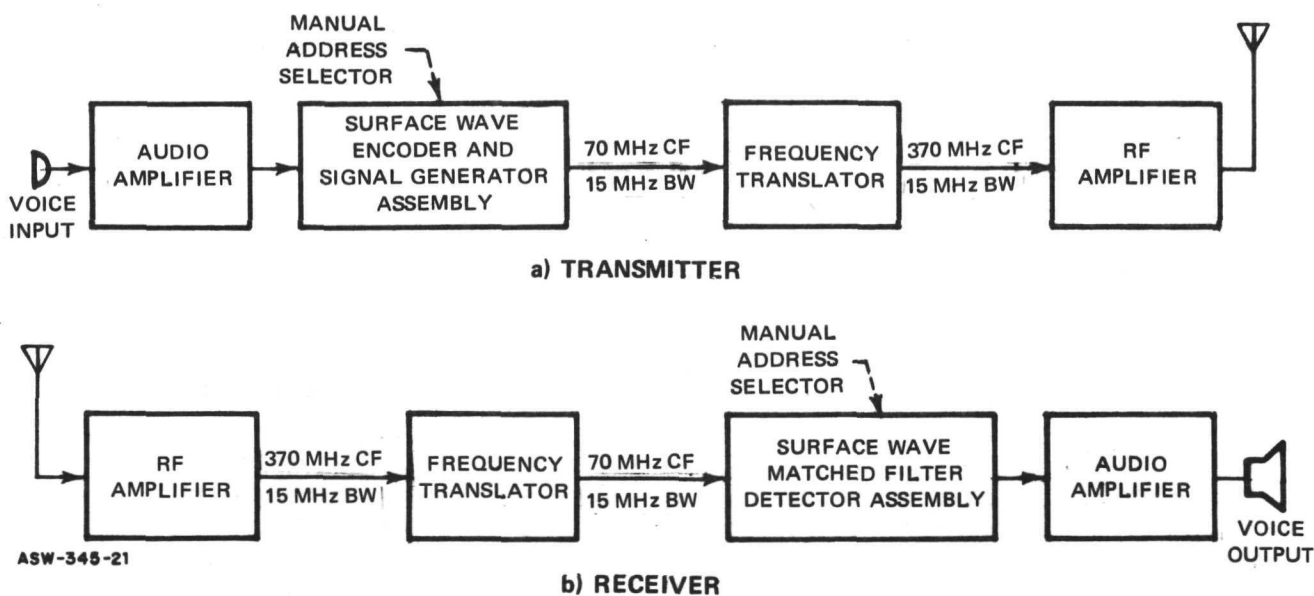

Figure 3-12. Proposed Spread Spectrum Communication Link

The encoded output signal is obtained by pulsing two surface wave devices selected by switches S1 and S2. (These are electronic switches; but mechanical switches are indicated for convenience of illustration.) A total of eight different codes is available since either end of each SWTDL can be pulsed. If both surface wave inputs A1 and C2 are pulsed simultaneously, the output is a signal composed of the sum of SWTDL A and SWTDL C outputs. If any two other inputs are pulsed, a different output appears, and a number of unique selectable addresses is provided by the two switches. In this illustration S1 and S2 are 8-position switches, each position connected to a different surface wave device input transducer. This results in 24 possible code choices if simultaneous connection of both switches to the same SWTDL is disallowed.\* For convenience of discussion, the notation (A1, C2) will be used to indicate that switch S1 is connected to input transducer A1 and switch S2 is connected to input transducer C2.

In the circuit of Figure 3-13, the four device output terminals are shown connected to a summing circuit to provide a composite output signal. In practice, that summation is accomplished by electrically connecting the output terminals of all four devices together, the transducer output impedances forming the summing network. In subsequent discussions, these terminals will be shown tied together; it should be remembered that the output is the sum of the individual signals.

Information is modulated onto the surface wave generated signals by controlling the relative timing of the pulses applied to switches S1 and S2. These time differences are small relative to the total duration of the output pulse, corresponding to a maximum of  $\pm \pi/2$  radians at 70 Mhz. The composite output signal is phase modulated by the information signal because the surface wave devices are linear and the two surface wave output signals add directly.

Signals generated by the surface wave devices described above are detected in the receiver by similar<sup>†</sup> devices connected to perform as matched filters. The received signal is first amplified and then applied simultaneously to all four surface wave devices in the receiver. Each selector switch selects one device output, and this provides the discrete address receiving capability in the proposed communication link. Extraction of the signal is discussed below by reference to Figure 3-14.

---

\*It may be desirable to reduce this number somewhat to obtain the best code cross correlation properties, but present indications are that at least 20 addresses can be provided for each SWTDL plug-in assembly.

<sup>†</sup>The same surface wave devices can be in both the transmit and the receive modes if connections are changed using appropriate transmit/receive switches.

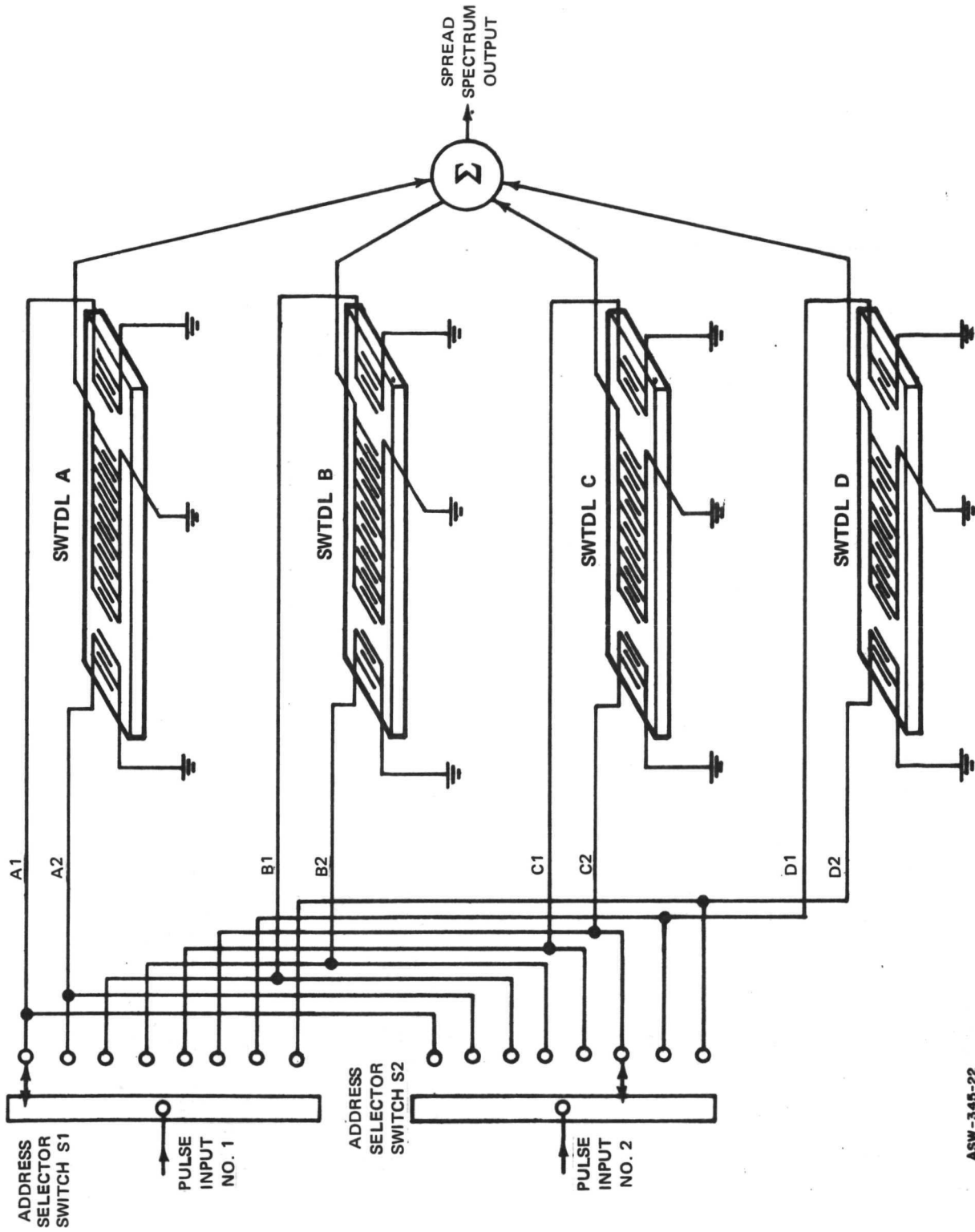
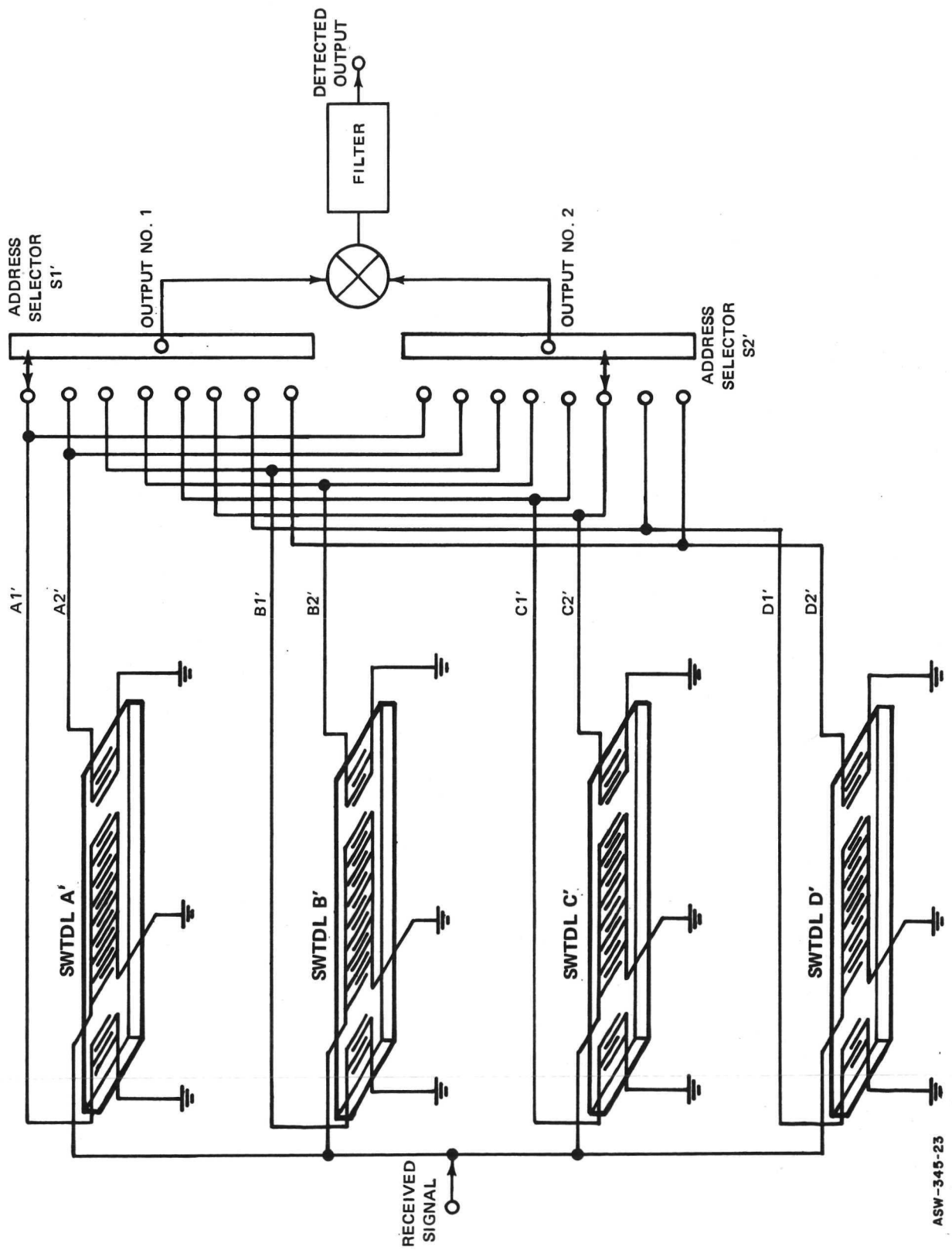

Figure 3-13. Surface Wave Signal Generator

ASW-345-22





ASW-345-23

Figure 3-14. Surface Wave Matched Filter Detection

### 3.3.2 Modulation And Demodulation Concept

The modulation and demodulation concept will be discussed in further detail here. In the transmitter, two surface wave devices having different PN codes are pulsed repetitively and almost simultaneously. The relative time of occurrence of the pulses is controlled by the information signal. Because the time difference is very slight compared to the duration of the surface wave device outputs, the output signals almost completely overlap. The two spread spectrum signals are linearly added and the result hard limited prior to transmission, yielding an essentially periodic train of PN encoded rf pulses. Information is obscured, residing almost entirely in the phase of the rf carrier.

Envelope detectors are not effective in extracting the information; discriminators are similarly at a great disadvantage, because the rf pulses occur periodically. Coherent detectors are defeated because the pulses can be intentionally made noncoherent. Square law detectors can also be made ineffective by employing a noise-like envelope modulation on the transmitter signal at the hard limiter output. This will not affect the performance of the surface wave detection technique.

The signal can be efficiently demodulated using two parallel processing surface wave matched filters, one designed for each of the transmitter surface wave devices. When the received signal is simultaneously applied to the two surface wave matched filters, each produces a single correlation peak. One of the peaks arises from the component of the signal generated by one transmitter surface wave device, and the other peak arises from that produced by the second transmitter device. The relative carrier phase of the two correlation peaks is a function of the information signal, and the information can be efficiently recovered by use of a phase detecting circuit.

Multiple channel operation can be obtained with this concept by providing several different codes in both the transmitter and the receiver, selecting different pairs to represent different addresses.

The surface wave signal generating and modulation concept will now be described by making reference to Figure 3-13 where four different SWTDL's are shown. In this case, however, the multitap output transducer of each device has a different phase reversal pattern, i.e., it has a different PN code structure. Although the code structures differ, each device produces an output signal whose bandwidth and duration are identical.

The two appropriate output transducers are selected for the desired receiver address.\* In this instance, the selector switches are shown connected to outputs A1' and C2' to correspond to the address choice (A1, C2) in the transmitter. For convenience, primes are used to relate receiver matched filters to transmitter signal generators, i.e., A1' is matched filter for A1, C2' is the matched filter for C2, etc.

Consider the nature of receiver output No. 1 in response to the signal generated by the transmitter when address (A1, C2) is selected. Surface wave device A' receives as an input the composite signal A1 + C2, and the selected output is the convolution of the received signal with the impulse response of the device. Using simplified notation, this is

$$(A1 + C2) * A1' = A1 * A1' + C2 * A1'$$

Similarly, receiver output No. 2 is

$$(A1 + C2) * C2' = A1 * C2' + C2 * C2'$$

If proper codes are chosen, the cross correlation terms A1\*C2' and C2\*A1' will produce only noise-like signals, but the autocorrelation terms (A1\*A1' and C2\*C2') will each produce a single predominant peak and many small, noise-like sidelobes. The main peak which occurs at receiver output No. 1 coincides in time with that which occurs at output No. 2, except for the small time difference corresponding to the modulation, i.e., the information signal.

The information is recovered by multiplying the output signals together as shown in Figure 3-14. When the autocorrelation peaks occur, the amplitude of the multiplier output is high<sup>†</sup>; at all other times, the output is low.

If the surface wave devices in the transmitter are triggered by time coincident positive pulses, the output of the multiplier is a positive pulse. If one of the pulses is delayed by an amount corresponding to 180-degree phase shift measured at the center frequency (70 MHz), the multiplier output is a negative pulse. Phase shifts less than 180 degrees can be employed and this makes analog signal transmission possible. (Digital signals can be transmitted by simply controlling the relative polarity of the two pulses used in the transmitter.)

---

\*Here, the received signal is applied to the transducers which served as output transducers in the transmitter, and the outputs are taken from those previously used as input transducers. Performance is the same when the input and output transducers are reversed, and the method shown here is chosen because it simplifies implementation in this application.

<sup>†</sup>The peak at the product detector output is a function of the transmitted information and is actually modulated in amplitude.

Suppose the receiver is set to address ( $A1'$ ,  $C2'$ ) but the received signal is ( $B2$ ,  $D2$ ). Receiver output No. 1 is  $B2*A1' + D2*A1'$ , and output No. 2 is  $B2*C2' + D2*C2'$ . If the codes selected have good correlation properties, the outputs contain no cross correlation peaks of significant amplitude, and good multichannel performance results.

Operation using these surface wave modulator and demodulator techniques is more clearly seen by reference to photographs of waveforms obtained using laboratory surface wave devices. Figure 3-15 illustrates the transmitter operation. The upper photograph shows the individual surface wave device outputs when they are pulsed simultaneously and the resulting composite signal. The composite signal is amplitude modulated, and a limiter is used to produce a constant envelope signal for transmission. The limited signals are shown in the lower photograph.

Figure 3-16 illustrates the operation of the matched filter detector in the receiver. When surface wave device A alone is pulsed, the output of  $A'$  contains a high correlation peak and low sidelobes; but the output of  $B'$  is noise-like, and the filtered product detector output has negligible amplitude (upper two photographs). In the lower two photographs, B alone is pulsed, and  $B'$  has a high peak output while  $A'$  is noise-like. Again, the filtered product detector output is small. However, when both A and B are simultaneously pulsed, both  $A'$  and  $B'$  produce strong autocorrelation peaks, and a prominent pulse appears at the filter output (middle two photographs). This set of photographs clearly demonstrates the ability to achieve unique address selection with this code multiplex wideband link concept.

### 3.3.3 Breadboard Communication Link Description

This subsection describes the design code multiplexed, wideband communication link using the surface wave devices and modulation techniques described previously. Block diagrams of the transmitter and the receiver are shown in Figure 3-17, with two SWTDL;s pictured for each to represent an arbitrarily selected address (code pair).

An address selector will be provided in both the transmitter and receiver to select the codes to be used in a specific transmission. The address selector in the transmitter also adjusts the pulser rate to a frequency in the range of 5 to 7 kHz.\* In the receiver, the address selector selects the code and sets the center frequency of a sampler phase lock loop to correspond to the pulser rate associated with that address.

In the transmitter, the pulser drives SWTDL No. 1 with repetitive short rise time periodic pulses. Each pulse is delayed by the voltage controlled delay circuit and applied to SWTDL No. 2; the amount of delay is

---

\*Selection of different pulser rates with different codes reduces the interference when two or more transmitters operate simultaneously.

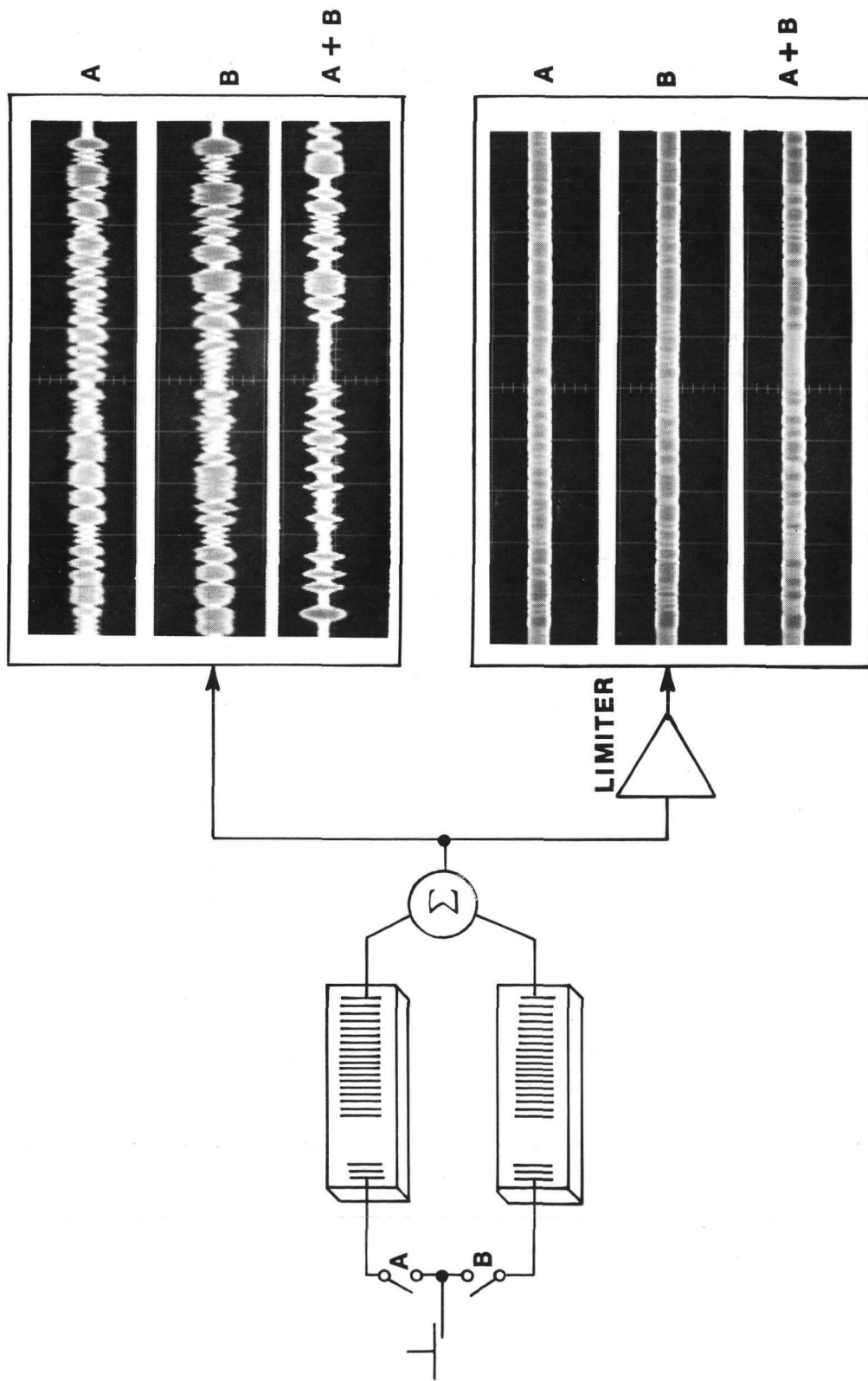
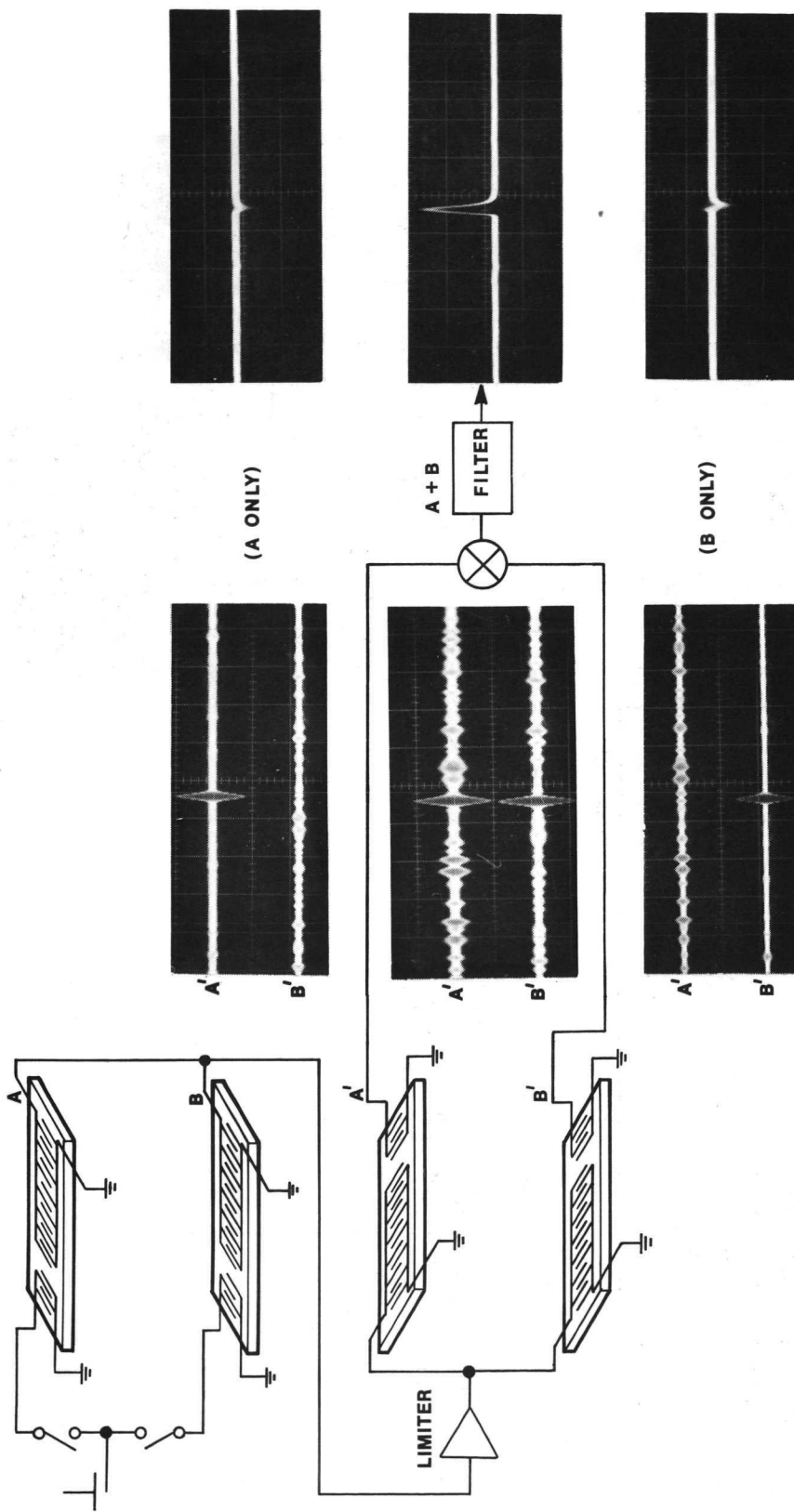

Figure 3-15. Simultaneously Transmitted Wideband Signals

ASW-345-24



ASW-345-25

Figure 3-16. Demonstration of Address Selection Capability

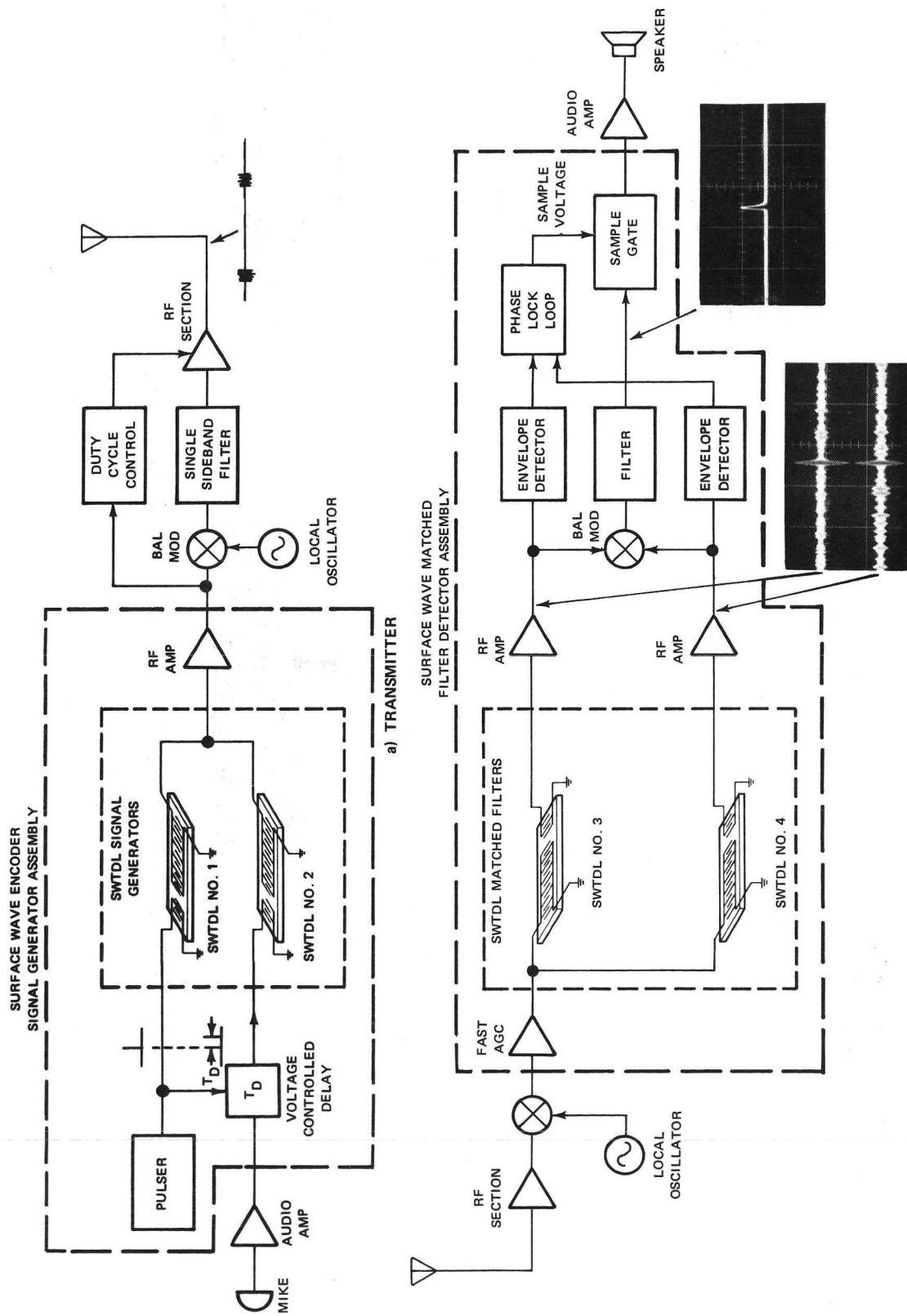

Figure 3-17. Communications Link Using Simultaneously Transmitted Wideband Signals

controlled by the audio signal. Both signals from SWTDL No. 1 and SWTDL No. 2 have a 70-MHz center frequency, a 15-MHz bandwidth (phase shift keyed), and a duration of 8.46  $\mu$ s. These signals are linearly summed and up converted to 370 MHz. The filter selects one sideband of the translated signal for transmission and the duty cycle control gates the final transmitter stage so that energy is transmitted only when a signal is present at the output of the SWTDL's (5 percent duty cycle).

In the receiver, the rf section amplifies the signal and it is down converted to 70 MHz. A fast acting AGC amplifier raises all signals to a sufficient level to drive the two SWTDL matched filters. The two amplified matched filter outputs are multiplied together by a balanced modulator, producing a series of positive and negative baseband pulses whose amplitude and polarity are determined by the voltage-controlled delay circuit in the transmitter. These pulses represent the sampled audio signal from the microphone. The outputs of the matched filters are also passed through an envelope detector and applied to a phase lock loop which locks to the pulser rate. This loop generates a narrow pulse centered on the main peak in the filtered product signal and pulse gates the peak through to the audio amplifier. This suppresses the sidelobe noise while it retains the information-carrying portion of the filter output signal.

The signals generated in the transmitter are synthesized by surface wave devices in response to pulses applied to them and do not require a stable crystal controlled carrier oscillator. The stability of the surface wave devices is such that no difficulty is encountered in operating over a wide range of temperatures. The frequency stability requirement for the local oscillator used in the frequency translators is lower than for most existing communication equipments, both wideband and narrowband. In the proposed implementation, frequency instabilities as high as  $10^{-5}$  produce no significant deteriorations in transceiver performance. Furthermore, with this technique, doppler effects are essentially negligible even for use in high speed aircraft.

### 3.3.4 Performance Characteristics

The communication link described in the previous subsections has characteristics which are significantly different than those exhibited by narrowband AM or FM links. Due to the unique implementation using parallel processing SWTDL's and the double pulse modulation technique, performance characteristics are also significantly different than those realized with wideband links implemented with serial correlation receivers.

Lockup Time. - The link described in Figure 3-17 performs a complete cross correlation of incoming signals in real time by the use of 127-tap surface wave matched filters, eliminating the need to synchronize a PN generator as required in serial correlation wideband receivers. The signal is demodulated by multiplying the output of two matched filters; consequently, there is no need for carrier regeneration, and allowance for carrier phase lock loop acquisition time is avoided.



After demodulation, the series of baseband pulses representing sampled speech can be fed directly through a filter and audio amplifier to the speaker. However, in noisy environments, the quality of the audio signal from the speaker can be improved if a narrowband sampling phase lock loop is used to gate away the sidelobe noise which exists between the pulses. The sampling phase lock loop will have a settling time of only 30 to 50 ms; and as a result, communication can be established almost immediately.

Code Multiplex Operation. - A number of users can operate simultaneously in the same frequency band. To receive a communication, the receiver must have the correct code plug-in package and the correct code must be set on the front panel selector switches. The approach using the code plug-in package is desirable because the loss of one receiver does not give away the whole library of codes, and yet it allows the user a reasonable number of switch selectable channels (about 20 for the case described here).

More than 100 different SWTDL plug-in assemblies can be provided, each of which can be designed so that a receiver with a different plug-in assembly will be prevented from reading a conversation.

Narrowband receivers with discriminators or nonlinear detectors which do not utilize privileged code information will be denied access. Access without privileged code information is difficult even for broadband receivers, because the transmitted signal is not sufficiently coherent to allow coherent detection, and induced distortion will frustrate a noncoherent detector.

An operator selects a desired address by choosing one of the available codes. Two users with the same plug-in can operate in the same frequency band when different codes are selected. The worst multiuser reception condition arises when the undesired signal is much stronger than the desired signal (i.e., when the desired transmitter is far away and the undesired transmitter is near).

The near-far problem is handled by the use of time multiplexed signals as shown in Figure 3-18a. The signals are designed to have a sufficiently small duty cycle (about 5 percent) so that the probability of simultaneous reception of the desired and undesired signal is quite small. All received signals are made to have equal amplitudes by a fast AGC circuit. If the desired signal and the strong interfering signal do not occur simultaneously, the small signal will now have the same strength as the large one as shown in Figure 3-18b. If the signals do occur simultaneously, the small signal will be lost.

After the equal amplitude signals are processed by the SWTDL matched filters, the undesired signal is suppressed and the desired signal is enhanced as shown in Figure 3-18c. If more than two users are simultaneously transmitting, more of the desired signals will be lost due

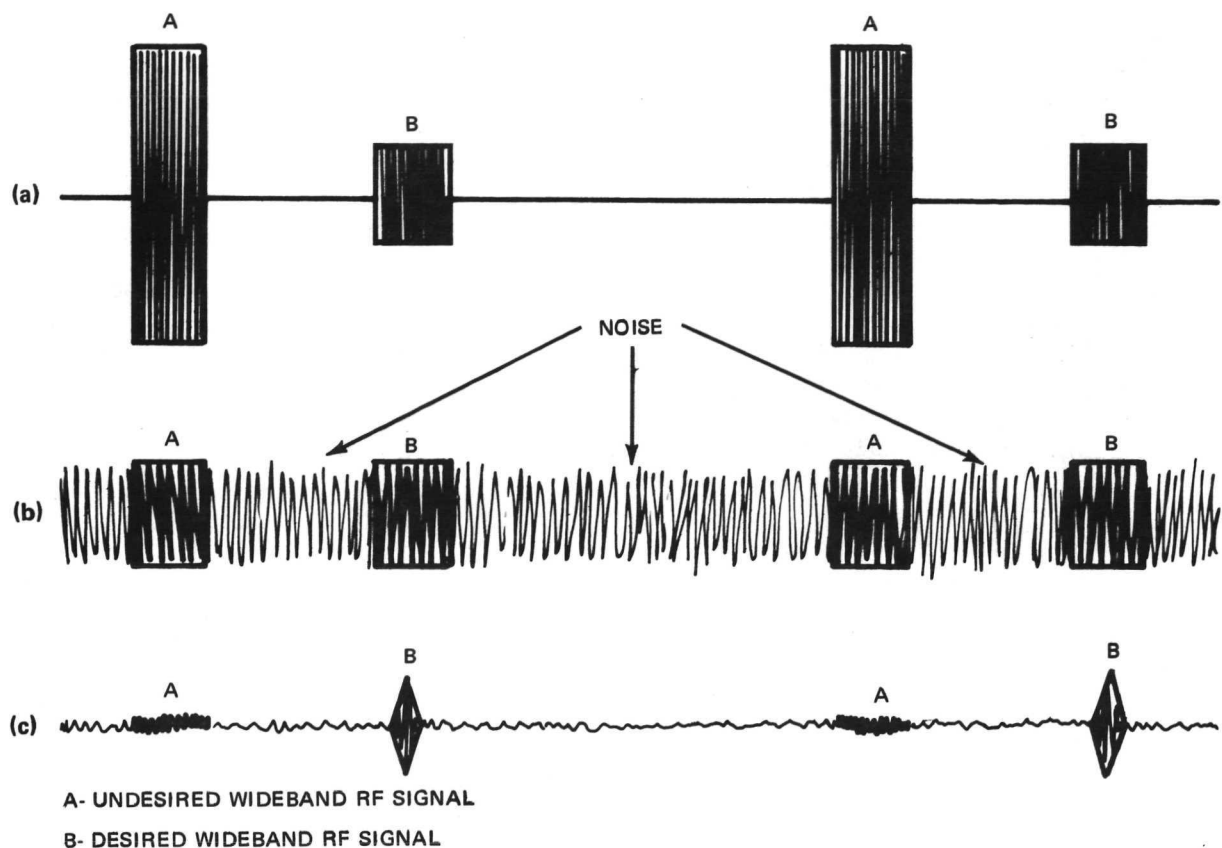

ASW-345-27

Figure 3-18. Detecting Weak Signal in the Presence of Strong Pulses

to simultaneous reception with large undesired signals. Experimental evidence indicates that voice quality is nearly perfect with two users, is noticeably degraded with five users, and will be understandable with eight users. This analysis is based on the worst case situation where all signals are much stronger than the desired signals. If the undesired signals are about the same strength or smaller than the desired signals, the degradation due to multiusers will be nearly unnoticeable.

Signal Detectability. - One of the features of spread spectrum communications is that the energy is spread over a wide bandwidth and is therefore difficult to detect by observers who do not benefit from privileged code information. This discussion does not refer to reading information from the signal, but merely to determining if a signal is being transmitted.

Jam Resistance. - This wideband communication link suppresses all signals which do not have its center frequency, bandwidth, and code structure. The 127-tap receiver SWTDL matched filter provides 21 dB of thermal Gaussian noise suppression, and the five percent duty cycle contributes an

additional 13 dB (constant transmitted energy criteria). The demodulator subtracts 4 to 6 dB from this improvement resulting in an overall thermal noise suppression of 28 to 30 dB. Suppression of narrowband rf signals is generally not as good as for Gaussian noise because certain rf signals are preferred by the matched filter. Experimental evidence for 127-tap matched filters indicates that the total rejection including the duty cycle improvement should be in the range of 20 to 26 dB.

Constant envelope, wideband rf signals received from friendly transmitters or from transmitters designed specifically for jamming purposes are also suppressed by the matched filter. The rejection of this noise is 26 to 30 dB if the jammer is not using the same code as the receiver. This suppression may be less than that for Gaussian independent wideband noise because it is code structure dependent.

This system has a very high rejection of pulse jamming from other friendly transmitters or from intentional jammers. Jamming pulses of any size (within the dynamic range of receiver front end) are ineffective unless they coincide with the received signal pulse. This allows the link to operate in the presence of jamming pulses 40 to 60 dB greater than the received signal.

### 3.4 Multiple Code Synthesizer

This section briefly discusses a multiple code synthesizer which utilizes acoustic surface wave devices to generate coherent PSK frequency hopped signals. Such a system has application in certain areas where range and range rate information are desired at the same time that the system is being used to transmit data. A breadboard model of such a synthesizer is now under development.\*

#### 3.4.1 Multiple Code Frequency Hopper Concept

Since surface wave devices have an impulse response which can be designed to have a wide range of center frequencies and phase shifts, it is possible to generate coherent PSK frequency hopped signals simply by pulsing the devices. A frequency hopped PSK signal is generated by alternately pulsing different surface wave devices, each designed for a specified center frequency (see Figure 3-19). The phase shifts are located such that the output signal has the properties of a cosine wave multiplied by a baseband signal with a biphase code such as a maximal sequence.

Each synthesizer consists of a stable rf pulser which provides a train of short, phase coherent rf pulses with a repetition rate precisely adjusted for a period equivalent to the length of the spread spectrum burst of the surface wave devices. Each pulse is applied to one

---

\*This work is being performed under Contract No. F30602-71-C-0197 for the Rome Air Development Center.

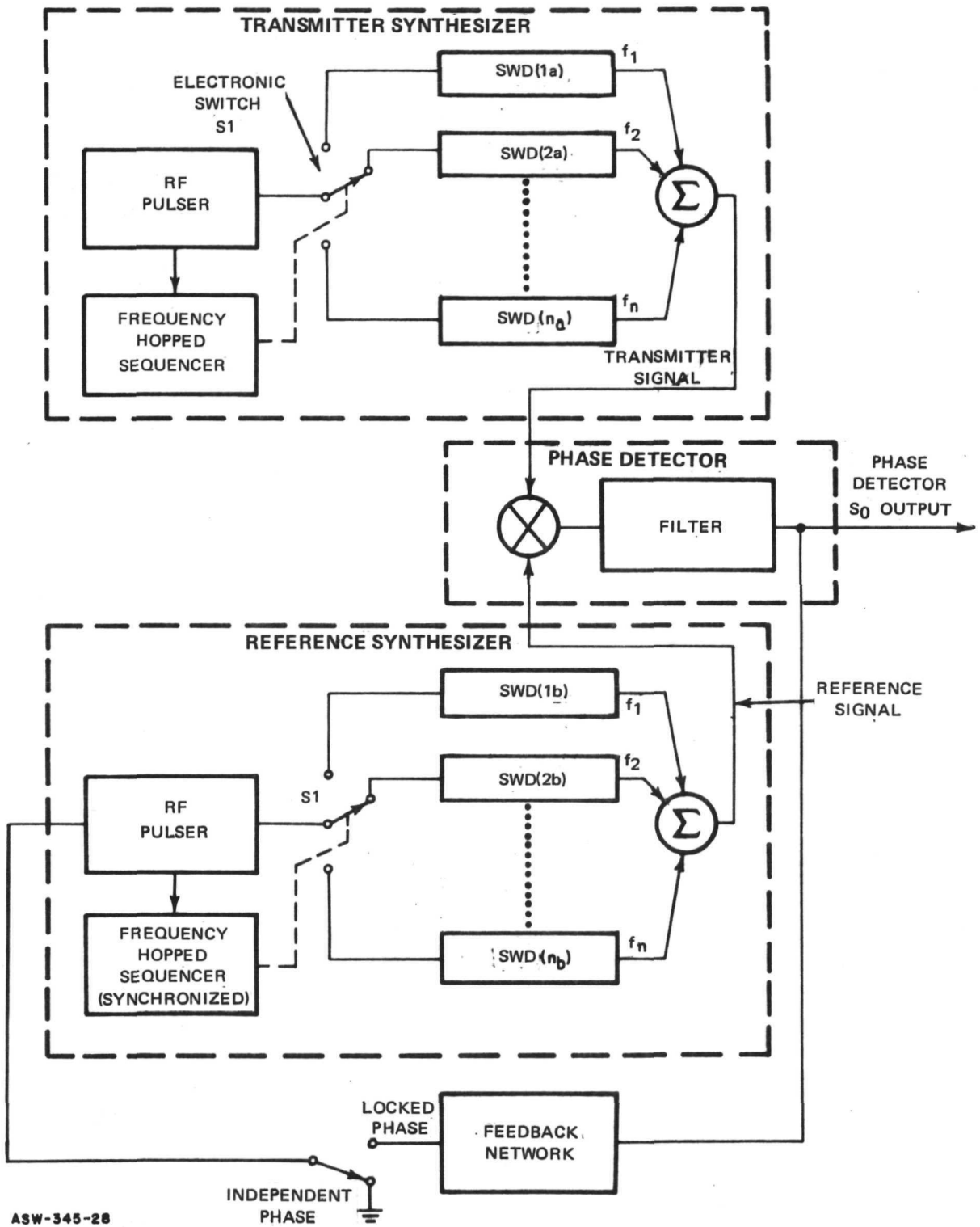

Figure 3-19. Synthesizer Functional Diagram

of  $n$  surface wave devices whose impulse response is summed with the output of the other  $n-1$  surface wave devices to make up the synthesizer output. The surface wave device ( $1_a$ ) is designed for example to provide a 40-MHz signal, PSK'd at a 10-MHz rate with a 127-chip linear maximal sequence code. The total impulse response, therefore, will have a period of precisely 12.7  $\mu$ s. Surface wave device ( $2_a$ ) has the same characteristics but its center frequency in this example is 50 MHz. Likewise, surface wave device ( $n_a$ ) has a center frequency of  $40 + 10 (n-1)$  MHz.

The electronic switch S1 is controlled by an FH sequencer to apply the pulse to one of the  $n$  surface wave signal generators at a time in a pseudorandom manner (see Figure 3-19). The resultant signal out of the surface wave devices is a constant envelope, PSK, frequency hopped signal whose phase at any point can be calculated if a reference phase and the sequence is known. If the pulse rate is lowered, the output signal will be 12.7  $\mu$ s bursts of rf energy separated by periods of no signal.

At first glance, the surface wave devices appear as signal generators which generate frequency components and establish an independent frequency reference. However, the surface wave devices are filters, and only pass frequencies they receive and alter the phase in a deterministic manner. It follows that the output of any two surface wave devices with input pulses which are coherent will be coherent (even when the envelope is not continuous).

When the surface wave devices and rf pulsers are not identical, the performance of the wideband receiver is reduced. The sensitivity is diminished because the receiver no longer acts as a perfect matched filter and ranging accuracy is reduced because of phase uncertainties. A seemingly random phase difference between the signals arises from uncontrolled tolerances in the surface wave devices and rf elements, while temperature drift and doppler contribute a deterministic component. The sensitivity loss (in dB) due to phase error is approximately

$$\text{Sensitivity Loss} \left| \begin{array}{l} \approx 20 \log \frac{\sin \bar{\phi}/2}{\bar{\phi}/2} \text{ for } \phi < \pi \\ \text{phase error} \end{array} \right.$$

where  $\bar{\phi}$  is the rms phase difference averaged over the integration time.

The sensitivity is also diminished when the ratio of transmitter signal amplitude to receiver signal amplitude is not constant. If the ratio has Gaussian distribution and standard deviation of  $\Delta$ , the receiver sensitivity is diminished by

$$\text{Sensitivity Loss} \left| \begin{array}{l} \text{Amplitude Variation} \\ = \log \frac{1}{1 + \Delta^2} \end{array} \right.$$

If both losses are small, the total sensitivity loss will be the sum of both losses. Note that if the rms phase uncertainty is less than one radian and the signal amplitude ratio has a standard deviation less than 20 percent, the receiver will have a sensitivity within one dB of theoretical optimum. The range uncertainty is simply limited by time jitter (i.e., phase jitter divided by the frequency).

A coherent PN/FH synthesizer implemented with surface wave devices as the prime signal generating elements is able to achieve phase jitter and amplitude uncertainty control sufficiently so that the receiver will operate within one dB of the theoretical. Experience with existing devices and predictions based on sound assumptions strongly indicate that these uncertainties are controlled sufficiently to reach this performance.

A coherent PN/FH synthesizer, offers many degrees of diversification which may be utilized to advantage in wideband, multipurpose communication links. The choice of code for any surface wave device is independent of the code used on the other devices. Since any code with good autocorrelation characteristics is appropriate for use at any or all of the frequencies, a more diverse address library is offered than in the case where the same code is used at all frequencies. Since the codes of the surface wave devices are not restricted to constant bit rates, 180-degree phase shifts, or codes generated by shift registers, waveforms with better cross correlation characteristics may be generated at no additional cost.

#### 4.0 BREADBOARD SURFACE WAVE TAPPED DELAY LINES

Four multiple tap surface wave delay lines were fabricated during the period of this contract. The four devices consist of two sets of encoder-decoder matched pairs.

These devices were fabricated on ST-cut quartz substrates using standard photoprocessing and etching techniques. ST-cut quartz was chosen because of its favorable temperature stability, availability, and reasonable cost. In each case, the conductive fingers are aluminum films having a thickness of approximately 2000 Angstroms. The properties of the two sets of devices are discussed below.

#### 4.1 Code 2 Devices

This set of laboratory breadboard devices was fabricated using a 127-chip linear maximal sequence as the encoding-decoding element. The code is shown in digital form below.

```
0 0 0 0 0 0 1 0 1 1 0 0 0 0 0 1 1 1 0 1 0 0 0 0 1 0 0 1 1 1 0 0 0 1 1 0 1 0 0 1 0 0 1 0 1 1 1 0 1 1
0 1 1 1 0 0 1 1 0 1 1 0 0 1 0 1 0 1 1 1 0 1 0 1 1 1 1 1 0 1 1 1 1 0 0 0 0 1 1 0 0 0 1 0 0 0 1 0 1 0 0
1 1 0 0 1 1 1 1 0 1 0 1 0 1 0 0 0 1 1 1 1 1 1 1 0 0 1
```

There is a 180-degree phase difference between the 0's and 1's. This phase reversal is accomplished on the surface wave device by reversing the tap polarities between the 0 grids and the 1 grids. A schematic diagram of the grid layout on the quartz substrate is shown in Figure 4-1.

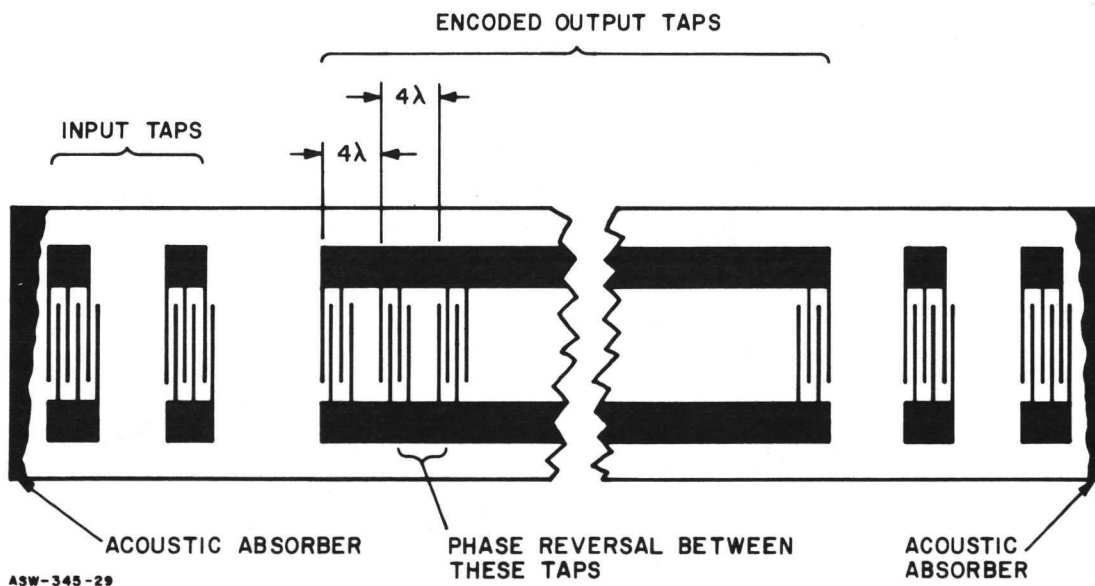

Figure 4-1. Code 2 Device Grid Layout on Quartz Substrate

The input tap consists of three grid pairs as shown in the figure. In this set of devices, only one set of input grids is connected. The additional inputs are provided to allow for the devices to be converted to the double pulse mode of modulation and to provide spare inputs.

The output taps consist of two grid pairs per code chip for a total of 254 output grids. These taps are spaced as shown in Figure 4-1, where  $\lambda$  is the acoustic wavelength of the device center frequency. The output taps are summed on conductive bussbars and fed through an active matching network to the device output terminal.

When a narrow voltage pulse is applied to a set of the input grids, 3-cycle surface wave trains are generated which propagate away from the input grids in opposite directions. The surface waves propagating toward the nearest end are absorbed with only a small reflection by an acoustic absorber placed on the crystal surface at the ends. The acoustic absorber used for these devices is a silicone rubber compound CRTV-5203 which provides an acoustical isolation in excess of 60 dB when applied at an angle to the direction of acoustic surface wave propagation.

The 3-cycle surface wave train passing in the opposite direction traverses the 127 sections of the output tap and produces a spread spectrum output of 15.9- $\mu$ s duration before it too is absorbed at the opposite end. A photograph of the oscilloscope trace of this spread spectrum is shown in Figure 4-2. An expanded view of a section of this signal is shown in Figure 4-3.

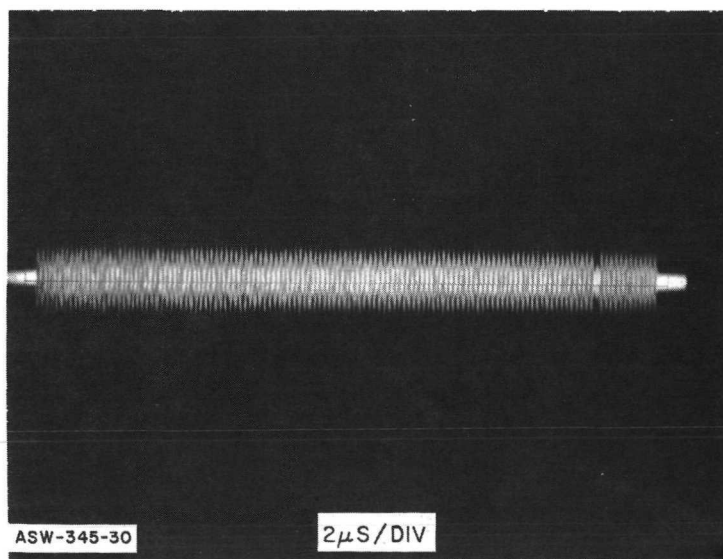

Figure 4-2. Spread Spectrum Output of Code 2 Encoder



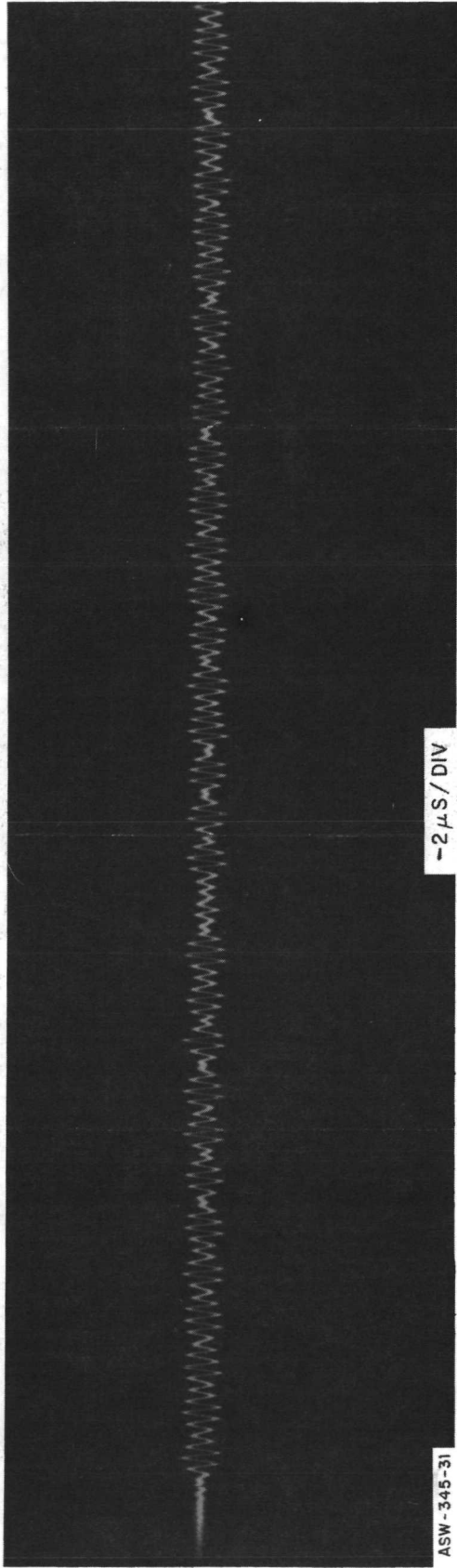

Figure 4-3. Expanded View of Spread Spectrum Output of Code 2 Encoder

This waveform is the impulse response of the device whose center frequency is determined by the grid spacing. It duplicates the phase inversions contained in the encoder taps and produces an encoded PSK signal corresponding to the code imprinted on the device. If this spread spectrum signal is amplified and fed into the decoder input where it is reconverted to an acoustic surface wave which passes in the opposite direction through the encoded output grids, the electrical output from these grids is the autocorrelation of the signal. This autocorrelation signal is shown in Figure 4-4. The expanded signal is shown in Figure 4-5.

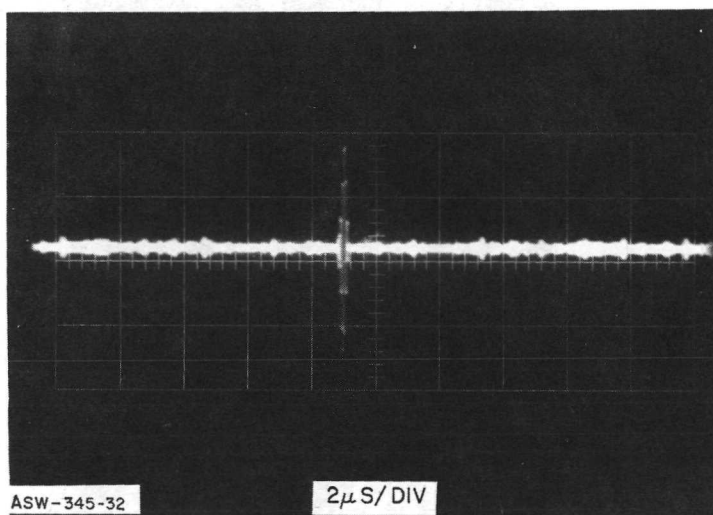

Figure 4-4. Autocorrelation Output From Decoder

This set of laboratory breadboard devices was encapsulated in metal shielding boxes along with active matching networks. Figure 4-6 shows an external view of the breadboard devices, and Figure 4-7 shows the surface wave encoder with the cover removed.

Figure 4-8 is a photograph showing the input and output active matching networks in the decoder package.

This group of devices was designed to meet the following specifications:

|                  |          |
|------------------|----------|
| Center Frequency | 32.0 MHz |
| Signal Bandwidth | 8.0 MHz  |
| Insertion Loss   | 0 dB     |

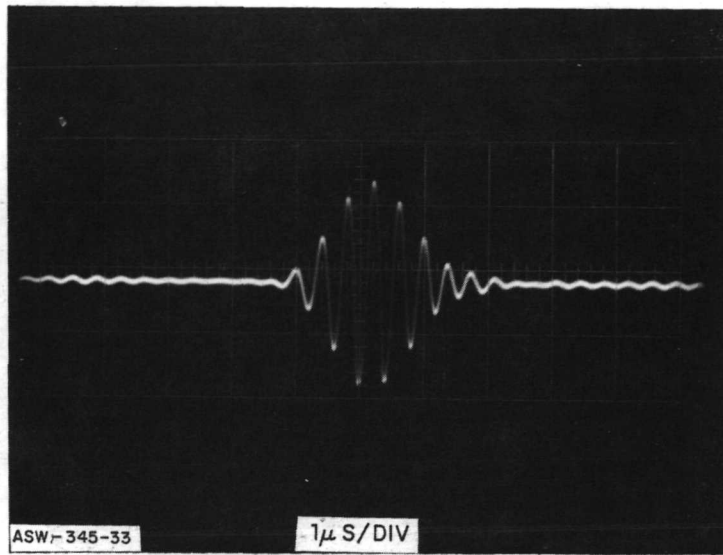
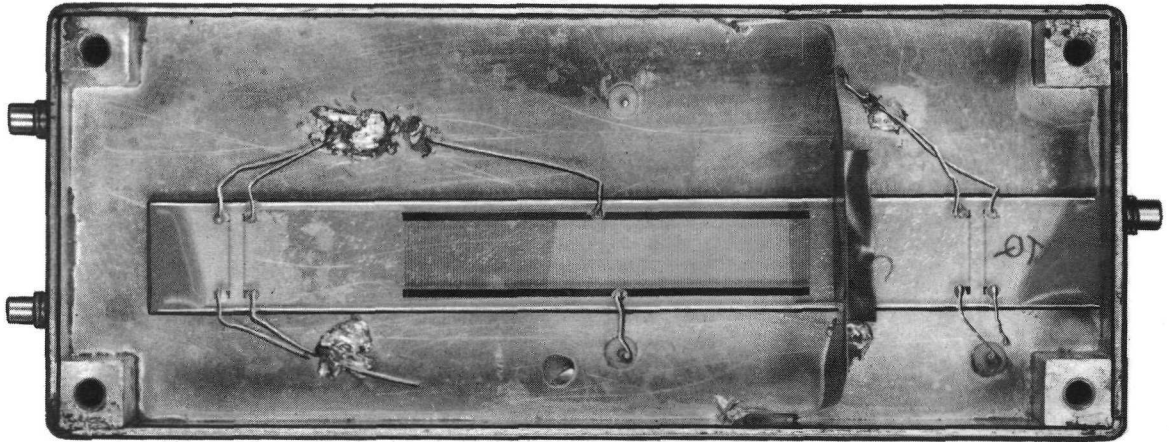

Figure 4-5. Expanded View of Autocorrelation Peak

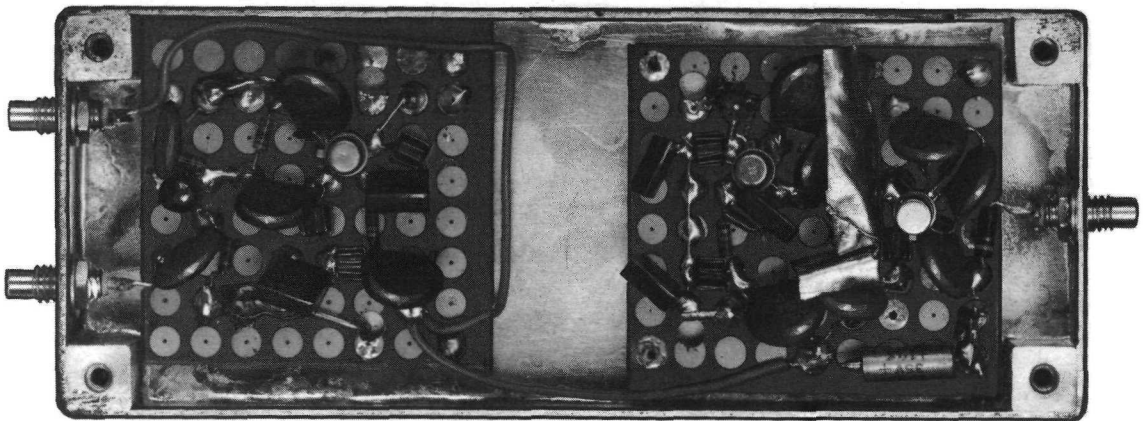

Figure 4-6. Code 2 Surface Wave Devices (Encoder and Decoder)



ASW-345-35  
71-10-1091

Figure 4-7. Code 2 Surface Wave Device  
(Encoder with cover Removed)



ASW-345-36  
7-10-1092

Figure 4-8. Code 2 Surface Wave Device (Decoder Package)

Test measurements of these parameters using an input pulse as shown in Figure 4-9 from an HP 215A pulse generator were made, and the following results obtained:

| <u>Parameter</u> | <u>Measured</u>              |
|------------------|------------------------------|
| Center Frequency | 32.2 MHz                     |
| Signal Bandwidth | 7.4 MHz                      |
| Insertion Loss*  | < 0 (Positive gain of .5 dB) |

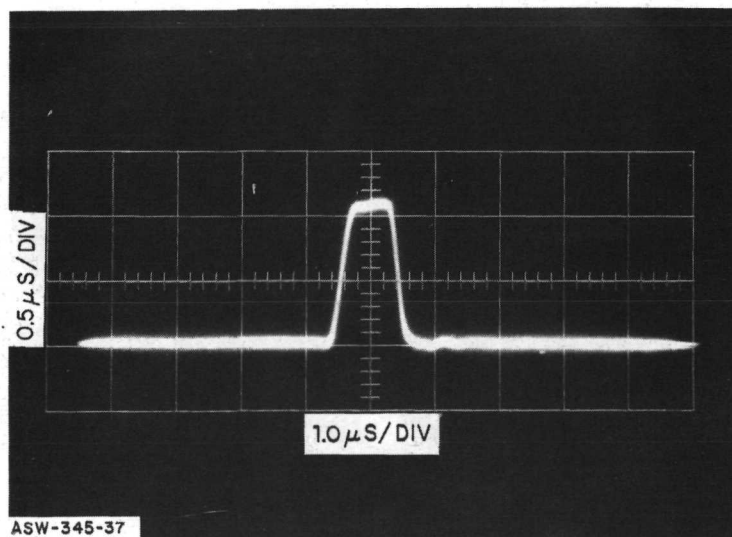

Figure 4-9. Test Input Pulse

#### 4.2 Code 4 Devices

Figure 4-10 shows the packaged code 4 devices. This pair of SWTDL's is nearly identical to the code 2 devices previously discussed. The only differences are in the manner in which the devices are connected to the input and outputs, their numbers, and in the biphasic code used. This set of matched devices uses a different member of the 127-chip family of linear maximal codes. The code used with these devices is shown in digital form as follows:

-----  
 \*Defined as  $20 \log \frac{(\text{Correlation Peak Voltage})}{(\text{Spread Spectrum Input Voltage})}$  measured at appropriate ports.  
 -----

```

0 0 0 0 0 0 1 1 0 0 0 0 1 0 0 1 0 0 1 1 1 1 1 1 1 0 1 1 1 1 1 0 0 0 1 1 1 0 1 0 1 0 1 0 0 1 0 1 0 1
1 1 1 0 1 0 0 1 1 0 0 1 1 1 0 0 1 1 0 1 0 1 1 0 0 0 1 0 0 0 1 0 1 1 1 1 0 1 1 0 0 1 0 0 0 0 1 1 1 1 0
0 1 0 1 1 0 1 1 1 0 0 0 0 0 1 0 1 0 0 0 1 1 0 1 1 0 1

```

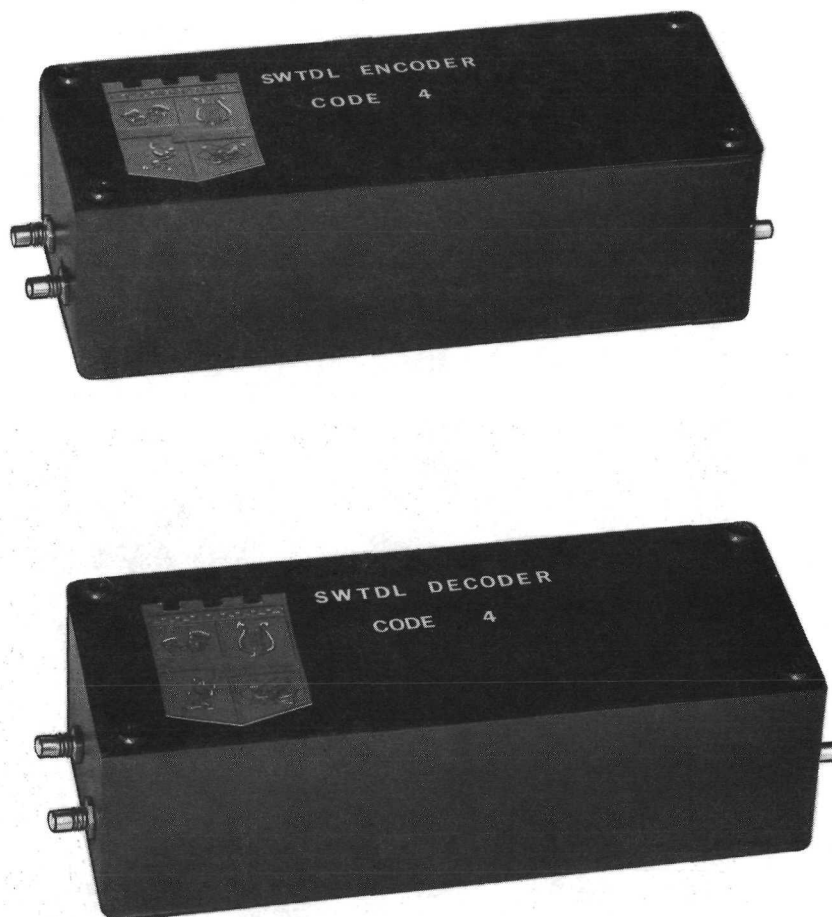

ASW-345-38  
71-10-1089

Figure 4-10. Code 4 Surface Wave Devices  
(Encoder and Decoder)

There is, again, a 180-degree phase shift between the 0's and 1's which is accomplished on the surface wave device by reversing the tap polarities between the 0 taps and the 1 taps.

The layout of the SWTDL is identical to that shown for the code 2 devices in Figure 4-1. The input taps on the encoder consist of three grid pairs and each code chip consist of two grid pairs separated from each adjacent chip by  $2\lambda$  (see Figure 4-1). In the encoder, two groups of input grids are connected to allow for operation in the superimposed signal modulator or pulse-pair modulation mode. In the decoder the input passes into the 127-chip grid pattern and two sets of three grid pairs are used for the dual outputs. The reason for these modifications is explained in the following discussion on pulse-pair modulation.

The capability for operation in the pulse-pair modulation is desired since this technique is very attractive because its performance is about equivalent to that of a coherent receiver using differential phase shift keying, but it is much less complex than a coherent receiver. It eliminates the need for regenerating a phase locked carrier to demodulate the rf signal.

Pulse-pair modulation is not practical with serial correlation receivers because they only generate the correlation function at one point (one value of  $\tau$ )\*. Using the surface wave correlator, the correlation function is generated for all values of  $\tau$ , permitting superimposed pulses to be resolved. Figure 4-11 gives a schematic representation of this technique. The surface wave signal generator is driven by a positive pulse at one transducer as shown in the diagram. The pulse is also modulated by the data and entered into the signal generator with a fixed time surface wave delay,  $T_d$ , which is established by spacing two input transducers on the device. The encoded rf signal is a superimposed combination of PN modulated rf pulses due to the first pulse and the delayed modulated pulse. When the rf signal reaches the decoder surface wave correlator (matched filter), the output is as shown in the trace with two successive autocorrelation peaks appearing at both output transducers.

Both autocorrelation functions are rf waves with triangular envelopes. The two signals are applied to the balanced modulator which multiplies them together to produce a baseband data signal. If both signal generator device input pulses are positive, as they are when the data signal is positive, the resulting baseband pulse is positive. When the data signal is negative, the pulses energizing the encoding surface wave correlator are opposite in phase and the carrier components in the autocorrelation peaks are also opposite in phase, yielding a negative baseband pulse.

This system does not require a reconstructed carrier because the baseband signals result automatically even on single bit or burst transmissions. The necessary signal delays in both the signal generator and the matched filter are incorporated on the devices. This is done simply by having the reference pulse drive a transducer which is situated a distance  $X_d$  in front of a transducer driven by the modulated pulse

$$X_d = \frac{\lambda}{4} + \frac{n\lambda}{2}$$

where:  $\lambda$  = surface wave wavelength

This is shown in Figure 4-12. The same is done for the output transducers on the matched filter.

---

\*The value  $\tau$  represents the relative phase between the received signal and the locally generated reference in a serial process.

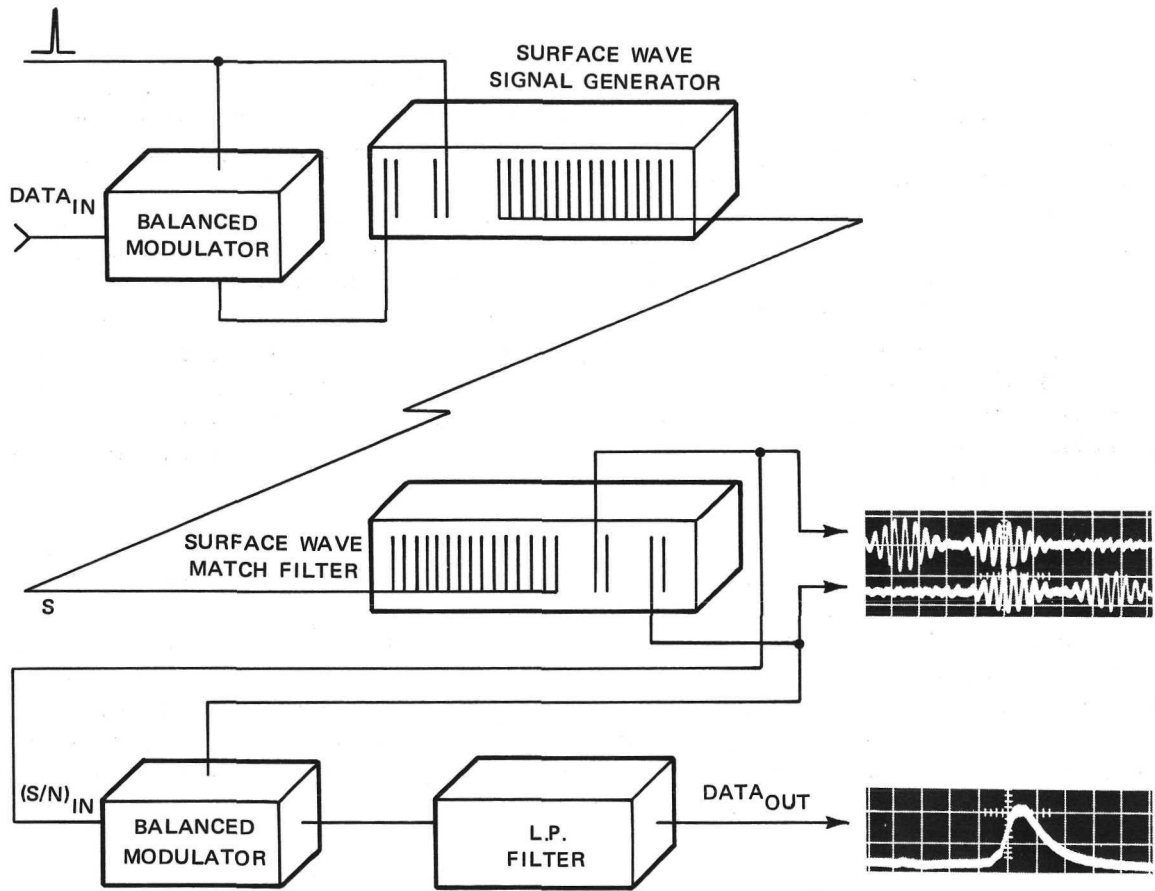

ASW-338-25

Figure 4-11. Double Pulse Mode PSK Technique



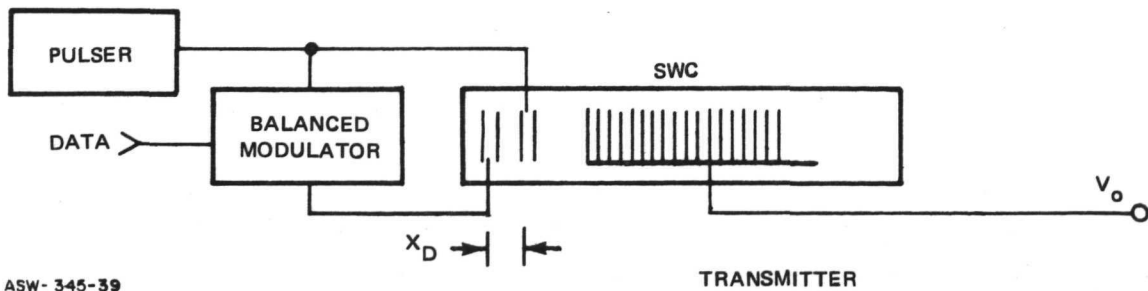

ASW-345-39

Figure 4-12. Superimposed Signal Modulation Technique Modulator

The performance of the superimposed signal modulation scheme in the presence of signal plus Gaussian independent noise is described below. (Multiple code interference is similar to band limited Gaussian noise.) Let  $s_1 + n_1$  be the signal plus noise at one matched filter transducer output and let  $s_2 + n_2$  be the delayed signal plus noise appearing at the other transducer output. These are applied to the inputs of a balanced modulator as shown in Figure 4-13.

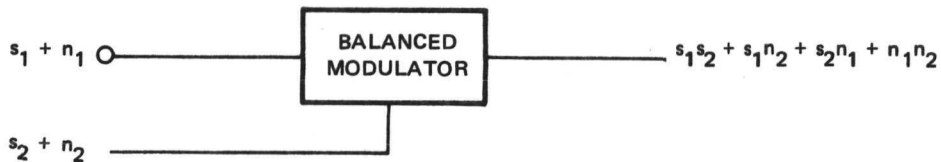

ASW-345-40

Figure 4-13. Coherent Phase Shift Keyed Detector

The signal component out of this balanced modulator is  $s_0$

where  $s_0 = s_1 \cdot s_2$

and the noise component out of this balanced modulator is  $n_0$

where  $n_0 = s_1 \cdot n_2 + s_2 \cdot n_1 + n_1 \cdot n_2$

In this system, the amplitude  $s_1$  will be approximately equal to the amplitude of  $s_2$ , and  $n_1$  will be approximately equal to  $n_2$ . First, consider the case where the signal-to-noise ratio is very high. In this case:

$$s_1 \cdot n_2 \gg n_1 \cdot n_2$$

$$s_2 \cdot n_1 \gg n_1 \cdot n_2$$

$$n_0 \approx 2 \cdot s_1 \cdot n_1$$

Note that the sum of these noise components is twice as great as in an ideal coherent detector. This results in the dashed line in Figure 4-14. This is the same effective performance as differential phase shift keyed detection frequently used in serial correlation systems. The signal-to-noise performance of the pulse-pair detector approaches this dashed line for high signal-to-noise ratios, whereas at low signal-to-noise ratios, the term  $n_1 \cdot n_2$  becomes significant. In the data-bus application only high values of signal-to-noise ratios are of interest, and the curve presented here illustrates the performance expected from using the pulse-pair modulation method.

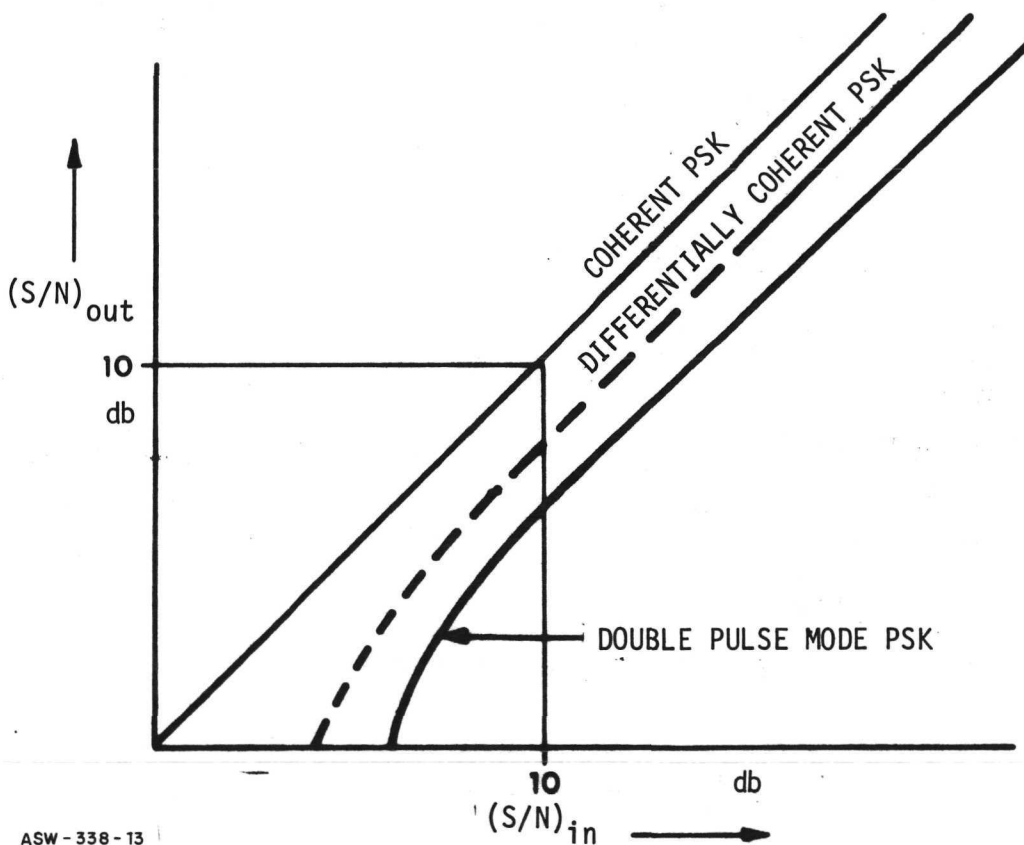

Figure 4-14. S/N Ratio Performance of Various Modulation Techniques

This method provides a modulation technique which simplifies the equipment required to receive differential phase shift keyed pseudo-noise signals using a surface wave matched filter detector. Many of the problems which are generally associated with carrier reconstruction have been eliminated, providing a more reliable system.

#### 4.3 Breadboard Performance Data

Table 4-1 contains the comparison between breadboard performance characteristics of a code 4 device and the original design objectives.

TABLE 4-1. COMPARISON DATA

| Design Objectives   | Code 4 Device<br>(Measured Data) |
|---|----------------------------------|
| Encoding - 127 Bits   | 127 Bits                         |
| Center Frequency* - 32 MHz  | 32.6 MHz                         |
| Signal Bandwidth* - 8 MHz   | 7.4 MHz                          |
| Insertion Loss*: - 0 dB<br>(Defined as<br>$20 \log \frac{\text{Correlation Peak Voltage}}{\text{Spread Spectrum Input Voltage}}$ )  | < 0 dB (slight gain)             |
| Material - ST-cut Quartz  | ST-cut Quartz                    |
| <p>Notes:</p> <p>These measurements were taken with approximately a 45-nanosecond pulse. The optimum pulse is closer to 15 nanoseconds wide. The 45-nanosecond wide pulse was used to provide information to the user similar to what can be achieved with standard test equipment. The narrower pulse would produce some improvement in performance.</p> <p>*These performance characteristics will vary with input pulse width.</p> |                                  |



THE **Magnavox** COMPANY • GOVERNMENT AND INDUSTRIAL DIVISION