

N72-18232

AMPEX

NASA CR-111983

**CASE FILE
COPY**

**BATCH FABRICATION PROCESS DEVELOPMENT FOR
FERRITE LOGIC CONDUCTORS**

RR 71-15

February 1972

**Ampex Corporation
Research and Advanced Technology Division**

Page intentionally left blank

BATCH FABRICATION PROCESS DEVELOPMENT FOR
FERRITE LOGIC CONDUCTORS

Prepared Under Contract No. NAS1-9836

by

Ampex Corporation
Research and Advanced Technology Division
Mail Station 3-19
401 Broadway
Redwood City, California 94063

for

NATIONAL AERONAUTICS AND SPACE ADMINISTRATION
Langley Research Center

Issued: Feb. 1972

Prepared by:



C. H. Heckler, Jr.
Project Manager

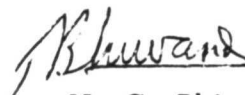

N. C. Bhiwandker
Member of Research Staff

Approved by:

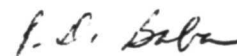

P. D. Baba
Manager, Ferrite Research
Section

ABSTRACT

A process for fabricating ultrareliable magnetic ferrite logic circuits is described in which the conductors are formed by a combination of two batch type processes - photolithography and electroplating - and a mechanized writing process for completing conductors in the third dimension. Up to 4 turns, through an aperture 1 mm in diameter, are formed by the described process. The number of joints in the conductors is reduced by use of this process to only those which are required for input, output and power connections of a logic block. To demonstrate feasibility, 8-stage magnetic ring counter circuits have been fabricated.

CONTENTS

	Page
ABSTRACT	
1.0 SUMMARY	1
2.0 INTRODUCTION	3
3.0 EDDY CURRENT SHIELD PROCESS	5
3.1 Sensitizing	5
3.2 Plating	7
3.3 Insulating	9
4.0 COUPLING LOOP PROCESS	15
5.0 DRIVE CONDUCTOR PROCESS	29
6.0 CONCLUSIONS AND RECOMMENDATIONS	43
APPENDIX A Drawings for Mechanical Writing Head Parts	47
APPENDIX B Wiring Diagram for Mechanized Writing Head	57

ILLUSTRATIONS

Figure	Title	Page
1	Basic Steps Common to the Three Plating Processes	6
2	Multistage Structure With Eddy Current Shield	8
3	Rotating Plating Bath with Filter and Pump	10
4	Unitized Structure After Insulating	13
5	Mechanized Writing Head System	17
6	Circuit Support Fixture	18
7	Writing Head Constuction	21
8(a)	Coupling Loop Etching Pattern, Top	22
8(b)	Coupling Loop Etching Pattern, Bottom	23
9	Unitized Structure with Plated Coupling Loops	25
10	Flow Diagram of Automated Process for Applying Coupling Loops	26
11	Automated Writing Configuration	28
12	Flow Diagram for Conductor Processes	30
13	Hole Etching Pattern for Drive Conductor Sheet	32
14	Etching Pattern: Top Side of Drive Conductor Sheet	34
15	Etching Pattern: Bottom Side of Drive Conductor Sheet	35
16	Unitized Structure with Completed Drive Conductor Pattern	38
17	Detailed Flow Diagram for Complete Magnetic Circuit Processing	40

A-1	Assembly Drawing: Mechanized Writing Head	48
A-2	Micropositioner, Motor Mounting Plate	49
A-3	Micropositioner, Base Plate	50
A-4	Micropositioner, Bracket	51
A-5	Micropositioner, Block #1	52
A-6	Micropositioner, Block #2	53
A-7	Micropositioner, Mounting Arm	54
A-8	Micropositioner, Mounting Bracket	55
A-9	Micropositioner, Holder Modification	56
A-10	Micropositioner, Adapter Modification	56
B-1	Control Circuit for Motorized Writing Head	58

TABLES

	Title	Page
1	Experimental Insulating Coating Materials	12
2	Commercial Parts for Mechanized Writing Head	19
3	Yield for Circuit Fabrication Processes	41

1.0 SUMMARY

The work conducted under this contract was directed at developing all the processes required for the semiautomatic application to ferrite logic structures of the coupling loops and drive conductors necessary for operation of 8-stage ring counter circuits. The conductors are formed by plating over a pattern applied by a combination of mechanized writing with gold ink and photolithographic etching of 25- μ m thick metallized Kapton sheets. A mechanized writing head was developed to accomplish the writing with gold ink. This writing head is compatible with an automated system for applying the conductors. The photolithographic etching of metallized Kapton sheets was developed to minimize the amount of writing required with the mechanized writing head and to simplify a major portion of the process through the use of a batch type operation.

Other processes required to be developed in conjunction with the conductor patterning procedure were: a plating process with good through-hole plating characteristics, an insulation process to insulate between layers of plating, and a bonding process for attaching the etched drive conductor sheets to the structures.

Two 8-stage ring counters were prepared using the developed processes as a practical demonstration of the feasibility of fabricating high reliability ferrite logic circuits and systems constructed by semi-automatic and batch type processes.

2.0 INTRODUCTION

Magnetic logic circuits in the past have failed to reach their inherent potential as the ultimate in high reliability logic circuits because the process of forming a circuit from a magnetic element by hand wiring is the same today as it was over two decades ago when magnetic logic circuits were first conceived [Ref. 1]. The magnetic elements have no known failure mechanism, and fail only if physically broken. Therefore, the reliability of magnetic logic circuits is determined by the conductor and insulation used to form the windings of these circuits. It has been shown in an earlier study that the reliability of a magnetic logic system is determined principally by the number of mechanical or solder joints and connections [Ref. 2] in the conductors. Hand-wired or machine-wired circuits have large numbers of these connections and, thereby, limited reliability. While the reliability obtainable with such circuits is higher than with semiconductor circuits, the difference has not been nearly as great as it can be.

In addition, hand-wound circuits are subject to human faults and are difficult to troubleshoot to determine the location and type of error. An additional disadvantage that both hand-wound and machine-wound circuits suffer is that both are completely serial processes, and, as such, advantage cannot be taken of the economies of batch type processing.

The fact that magnetic circuits need not be formed by wiring, with the resultant large number of unreliable joints and other of the disadvantages listed above, was shown in a preceding contract [Ref. 3]. In that study it was shown that the conductors could be applied to ferrite logic

devices by plating to form continuous joint-free conductors. That study charted the course to be followed to achieve the ultimate in high reliability logic circuits. Once the plating process was demonstrated to be feasible, a number of additional advantages became apparent. The plating process is amenable to automatic or batch processing which will result in accurately fabricated and reproducible circuits. This process also provides, for the first time, the ability to control the resistance and inductance of a conductor by controlling the width along its length. In the past the size of wire used was often determined by the need to fit a specified number of wires through an aperture or by the requirement for a small radius bend to minimize the inductance or inductive coupling.

The work reported here has been concerned with the further development of this plated conductor process by investigating semiautomatic and batch type processes for forming the conductor patterns, to move a step closer to the realization of a process for automated fabrication of complete ferrite logic circuits and systems. To demonstrate feasibility, two ring-counter circuits of the bimaterial multistage type developed in the preceding contract were fabricated with all conductors formed by plating using the mechanized patterning process developed.

3.0 EDDY CURRENT SHIELD PROCESS

A basic sequence of steps is repeated in the three major processes required for the batch processing of ferrite logic circuit conductors. The eddy current shield, the coupling loop, and the drive conductor process steps are shown in Fig. 1. The major difference between the three processes lies in the method of sensitizing the structure with the desired conductor pattern prior to copper plating. Therefore, in this section, the sensitizing, the plating and the insulating steps will be described, but in sections 4.0 and 5.0 only the sensitizing steps will be covered.

3.1 Sensitizing

The process used in the preceding contract, NAS1-7878, to sensitize three of the surfaces of multistage ferrite logic structures for copper plating to form an eddy current shield was to hand-paint these surfaces using gold resinate ink. This method, while satisfactory for a small number of samples, is slow, tedious and not amenable to batch processing. Also, care was required to prevent excessive coating thickness which resulted in blistering of the gold surface after curing. The continued use of the gold resinate for sensitizing was desirable since the degree of adhesion between ferrite and the gold deposited during curing had previously been determined not to set up magnetostrictive strains in the multistage logic structure after plating.

Spraying has been found to be a suitable and effective method of applying gold resinate to the surfaces to be plated to form the eddy

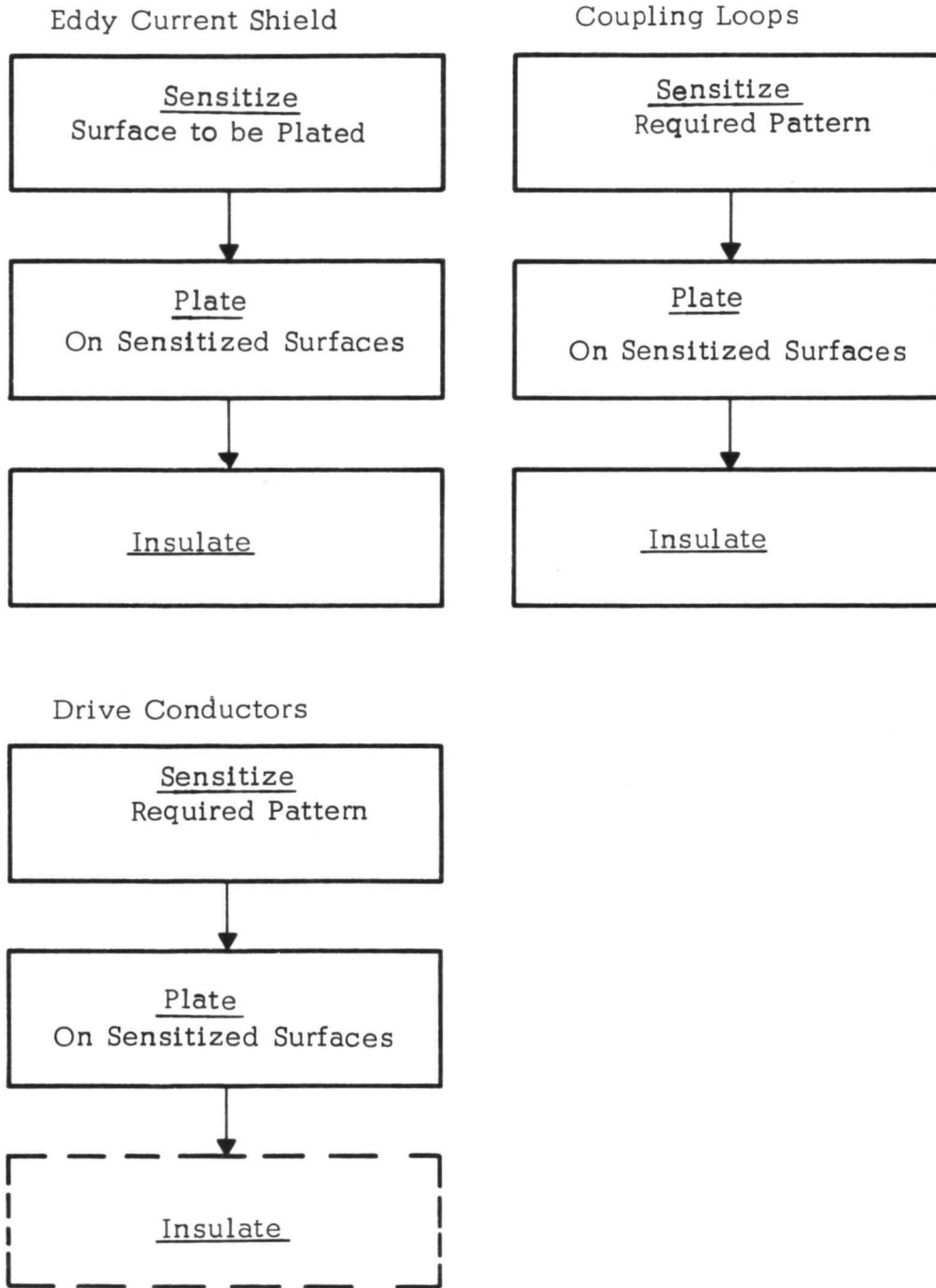

Fig. 1 Basic Steps Common to the Three Plating Processes

current shield. Englehard Squeegee Bright Gold Type 8119^{*} gold resinate is thinned with 50% by volume of toluene to lower the viscosity to a value suitable for spraying. A number of structures are mounted side by side in a frame, all in the same plane, with their apertures at right angles to the plane. The group of structures is sprayed from the front, so that the front and sides are completely coated with the gold resinate, leaving the back surface uncoated. Spraying provides a uniform coating with deep penetrating power for coating the inside of the apertures. The gold resinate is first dried at 300°K for 30 minutes, and then cured with a 12-1/2 minute 775°K heating cycle. During the first 2-1/2 minutes of the heating cycle, the structure is lowered at a velocity of 250 mm/min into the 775°K hot zone of a vertical tube furnace, and, after a ten minute soak, removed from the furnace.

The curing is conducted in an oxygen rich atmosphere to facilitate oxidation of the resinate. This process for sensitizing ferrite logic structures is equally adaptable to both batch type processing and automated processing, as each of the operations involved can be performed either on a group of structures or on a single structure.

3.2 Plating

The quality of the plating of the eddy current shield for the fabrication of logic circuits with plated conductors is critical since this plating serves as the base for all subsequent layers of insulation and conductors. This requires that the plating for the eddy current shield be uniform over the outer surfaces and through the aperture. A multistage logic structure with plated eddy current shield is shown in Fig. 2. To obtain good through-hole

* Englehard Industries, Inc., Hanovia Liquid Gold Div., East Newark, N. J.

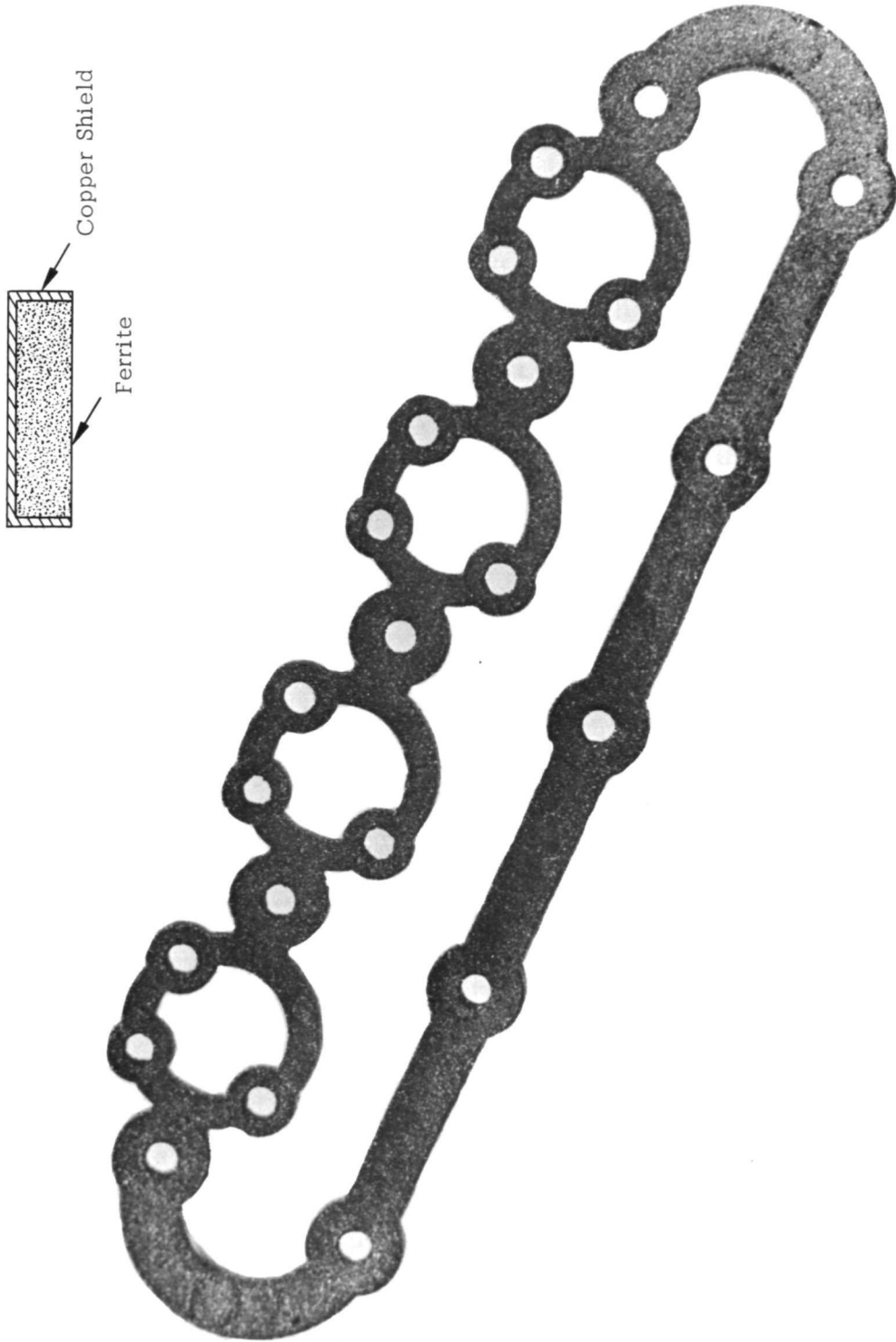

Fig. 2 Multi-stage Structure With Eddy Current Shield

plating, a rotating plating bath was used. To obtain smooth surfaces, free from embedded particulate matter, the bath was continuously filtered during plating. The plating bath used was a conventional copper sulfate formulation containing 225 g/liter of CuSO_4 , 32 ml/liter of H_2SO_4 and 30 mg/liter of Cl^- . No commercial brightener was used so a soft copper plating with a nonreflective surface resulted. This type of surface improved the adhesion between the copper and the insulating layers. The rotating plating bath, together with filter and pump, is shown in Fig. 3. The filter is a 1.5 micron Millipore filter, and the bath is filtered at a rate of 625 ml per minute. It has been found necessary to take special precautions when inserting structures in the plating bath to ensure that no air bubbles are trapped in the apertures. The structures are sprayed after immersion with the efflux of the plating fluid from the filter, after which they are inspected to verify that all bubbles have been removed.

All plating is done at a current density of $5.4 \cdot 10^2$ amps per square meter of plated surface which requires 50 seconds of plating per μm of copper. The eddy current shields are plated to a 100 μm thickness as are the drive conductors. The coupling loops are plated to a 50 μm thickness. It should be noted, however, that the optimum thickness for the coupling loops has not yet been determined.

3.3 Insulation

The characteristics of the insulation material used to insulate between conductive layers of the multistage ferrite logic circuits are determined by a combination of the requirements of the conductor application process, the shape of the logic structures, and the requirement that the insulation be reliably stable when exposed for long periods to severe environments. The last requirement is imposed since the reliability of the circuits prepared by the plated conductor process will be determined by the stability

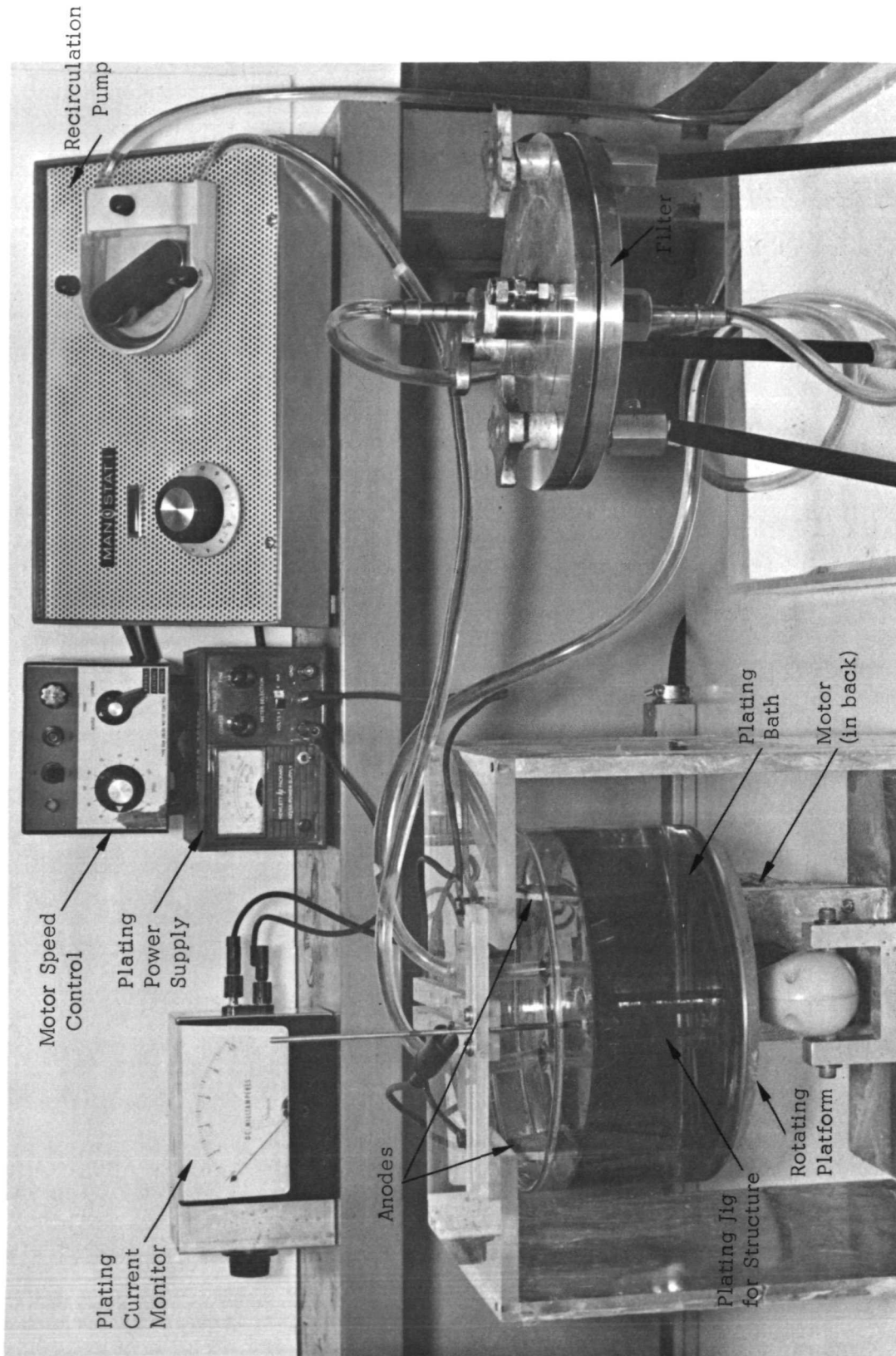

Fig. 3 Rotating Plating Bath with Filter and Pump

of the insulator. The minimum characteristics required in the insulating material are: stability at 570°K, resistance to sulfuric acid, and the ability to coat edges.

The requirements for stability of the insulation at 570°K and resistance to attack by a 5% sulfuric acid solution are imposed by the conductor application process. These characteristics are obtained in those insulating materials which meet the severe environment requirement. However, the third requirement, to provide good edge coverage on logic structures which have a rectangular cross-section and an edge radius of less than 130 μm , has been the most difficult characteristic to obtain. A number of high temperature insulating materials have been evaluated, and all have given the same result: viz., that good edge coating requires a multilayer build-up of the insulation. The only material evaluated which gave good edge coating in a single coat was the Imidalloy, a solventless polyimide by Toshiba. However, this material developed cracks during curing and was, therefore, unusable.

The insulating coatings evaluated are listed in Table 1. The methods of application used in evaluating the insulating coatings have been: draw coating, dip coating, and spray coating. Since the high temperature capability of the Pyre ML insulation is higher than for the other materials, and the characteristics have been more extensively determined because of its use as a magnet wire coating, this insulation has been used for the ring counter circuits fabricated during this contract.

The Pyre ML insulation is applied in four spray coats and two dip coatings. Prior to the first spray coating cycle, the structure is heated using infrared lamps to a temperature of 370°K to promote rapid volatilization of the solvents. The structure is sprayed with a solution of equal parts of Pyre ML varnish and N-Methyl-2-Pyrrolidone. After drying, the coating is

partially cured by baking at 420°K for one hour. This is followed by a second spray coating cycle and then the first dip coating cycle. The structure is immersed in undiluted Pyre ML slowly to avoid trapping air in the apertures, removed, and the apertures cleared of excess material by passing 250 μ m diameter wires through the apertures. Other methods of clearing the apertures of excess insulation have been investigated that would be more suitable for automatic processing. However, these methods would require complex controls and would be most suitable for processing large numbers of structures. Since a large number of structures were not to be processed, the simpler method of wire probes was used to clear the apertures of excess material. After clearing the apertures, the dip coat is dried and partially cured by rotating the structure at approximately 1 revolution per second and baking at 420°K for one hour. The insulating process is completed with two additional spray coating cycles, and a second dip coating cycle. An insulated unitized structure is shown in Fig. 4.

Table 1 Experimental Insulating Coating Materials

Insulation	Supplier	Type
Pyre ML	E.I. duPont de Nemours & Co., Inc. Wilmington, Delaware	Polyimide
Imidalloy TVB-2702	Toshiba Tokyo Shibaura Electric Co. Ltd. Tokyo, Japan	Solventless Polyimide
EpoxyLite #814	EpoxyLite Corp. South El Monte, Calif.	Epoxy
Thermo Resist TR 150-25	Thermo Resist Inc. Fullerton, Calif.	Polyimide

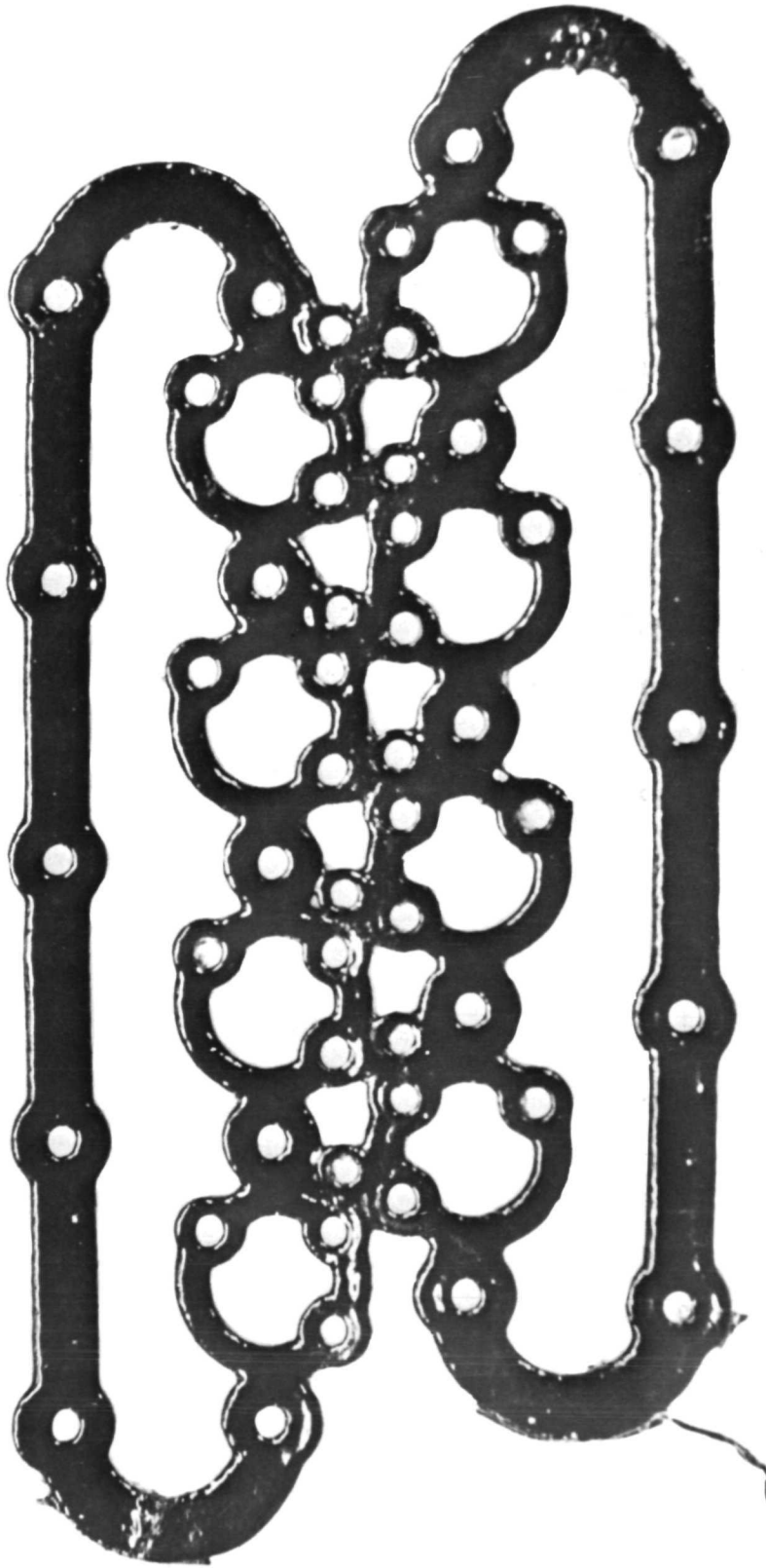

Fig. 4 Unitized Structure After Insulating

The problem of edge coverage arises from the action of the relatively large surface tension forces of the insulating materials. The use of the multiple coating process has been used to obtain acceptable edge coating with such materials. Although this process is amenable to automation for large quantity production, its use for small quantities is time consuming. For this reason alternate methods of insulating, more suitable to limited quantity production, have been sought. Two methods have been found which have not been fully investigated, but show promise of producing a one-coat process. In one, the surface tension of the insulating material is used to prevent depletion at the edges by covering the top and bottom surfaces of the structure with a sheet of wettable material to which the Pyre ML will not bond during the drying and curing portions of the coating process. In the second method, insulating gaskets of Kapton^{*}, a polyimide sheet, having the same shape as the structure but with slightly wider legs, are bonded with a high temperature adhesive to the top and bottom surfaces. The Kapton gaskets are prepared by the photolithographic technique described under Drive Conductor Process (Section 5.0).

* E.I. duPont de Nemours & Co. Inc.
Fabrics and Finishing Dept., Wilmington, Del.

4.0 COUPLING LOOP PROCESS

A process for sensitizing the conductor pattern onto a ferrite logic structure, to be successful, must be capable of forming a three-dimensional pattern as the conductors must form turns around the legs of a structure for circuit operation. In the case of the coupling loops, the conductors pass through the input aperture, output aperture, and clipper core of adjacent stages with one turn, two turns, and one turn respectively. These apertures, after application of the eddy current shield and insulation, are approximately 0.70 mm in diameter, and 0.90 mm deep. This geometry precludes the use of conventional printing techniques to form the coupling loop patterns.

A number of processes have been considered as candidates for forming this three-dimensional pattern. In addition to evaluating their suitability for this patterning, their adaptability to automated or batch type processing was also considered. Among those methods considered were:

1. Encapsulation of the structures in a plastic or ceramic material with a molded hole pattern such that each hole would accommodate a single plated conductor.
2. Decals, to transfer a conductive conductor pattern to the vertical walls, and to the top and bottom surfaces of the structure.

3. Electrostatic printing, which has been used effectively for printing on irregular surfaces, to print the conductor pattern on the vertical walls and on the top and bottom surfaces of the structure.
4. Laser beam to selectively expose a photosensitive coating applied to the vertical walls of the structures to permit formation of the conductor pattern by either plating or etching.
5. Mechanized three-dimensional writing head to draw with a conductive ink the conductor pattern on the vertical walls and on the top and bottom surfaces of the structure.

The mechanized writing head was judged to be the preferred process from an assessment of the degree of difficulty of the technical problems to be solved, the flexibility of the patterns produced, and compatibility of the head with automated processing techniques. The process developed for pattern sensitizing using the mechanized writing head closely parallels the process used to establish the feasibility of plating conductors on ferrite structures [Ref. 3]. In that process the conductor pattern was formed by hand painting with a gold resinate. With the mechanized writing head, the gold resinate is also used but it is applied through a pressurized capillary-bore needle attached to a three-dimension micropositioner.

The mechanized writing head is shown in Fig. 5 without the support fixture used to hold the structure while writing. A closeup of the support fixture is shown in Fig. 6. It is designed to allow writing on both sides of a structure. Travel in the three coordinate directions is motorized with the x and y directions controlled by a joy stick, and the z direction is controlled by two pushbuttons. The direction of movement of the joy stick controls the direction of travel of the micropositioner while the amount of

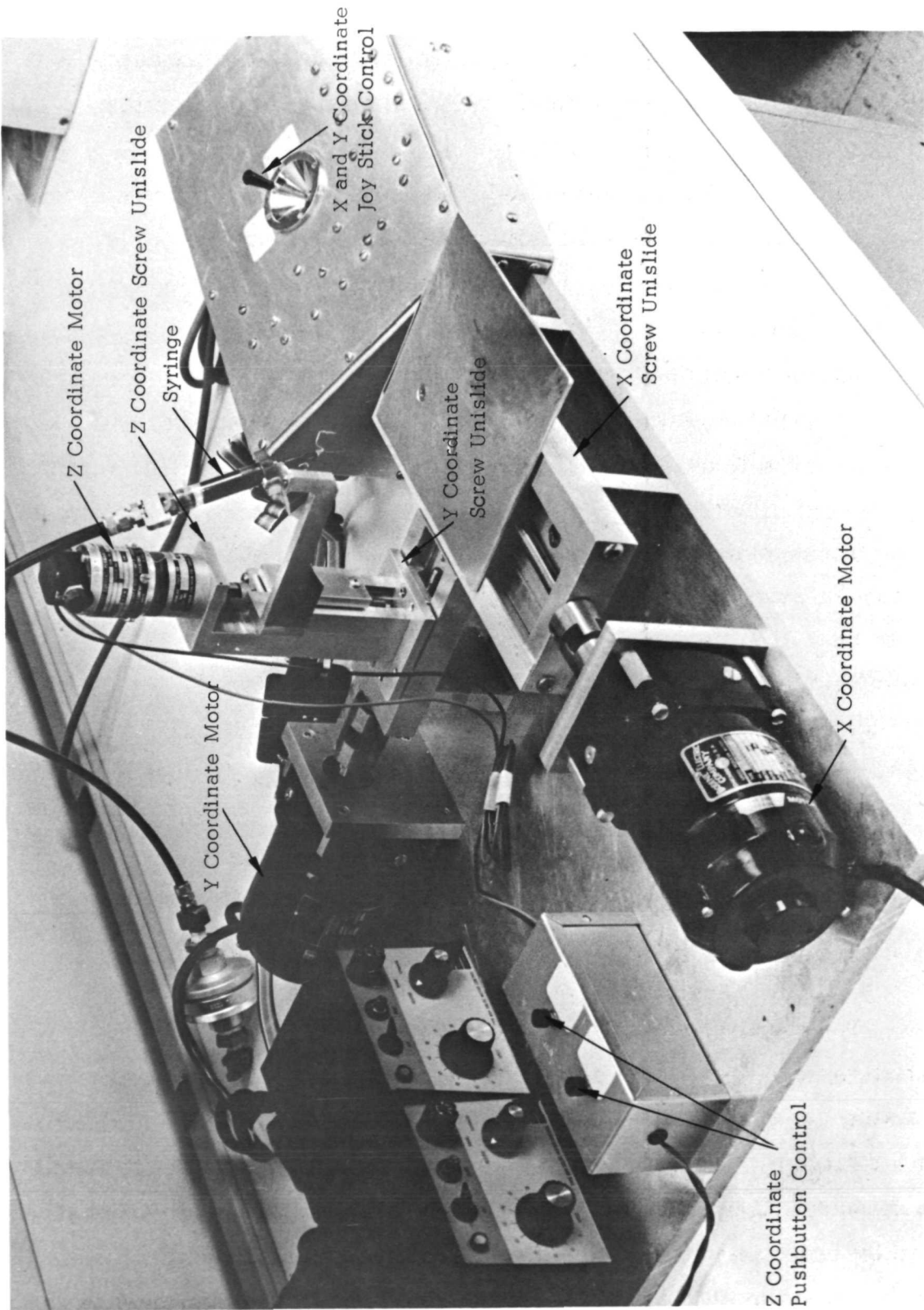

Fig. 5 Mechanized Writing Head System

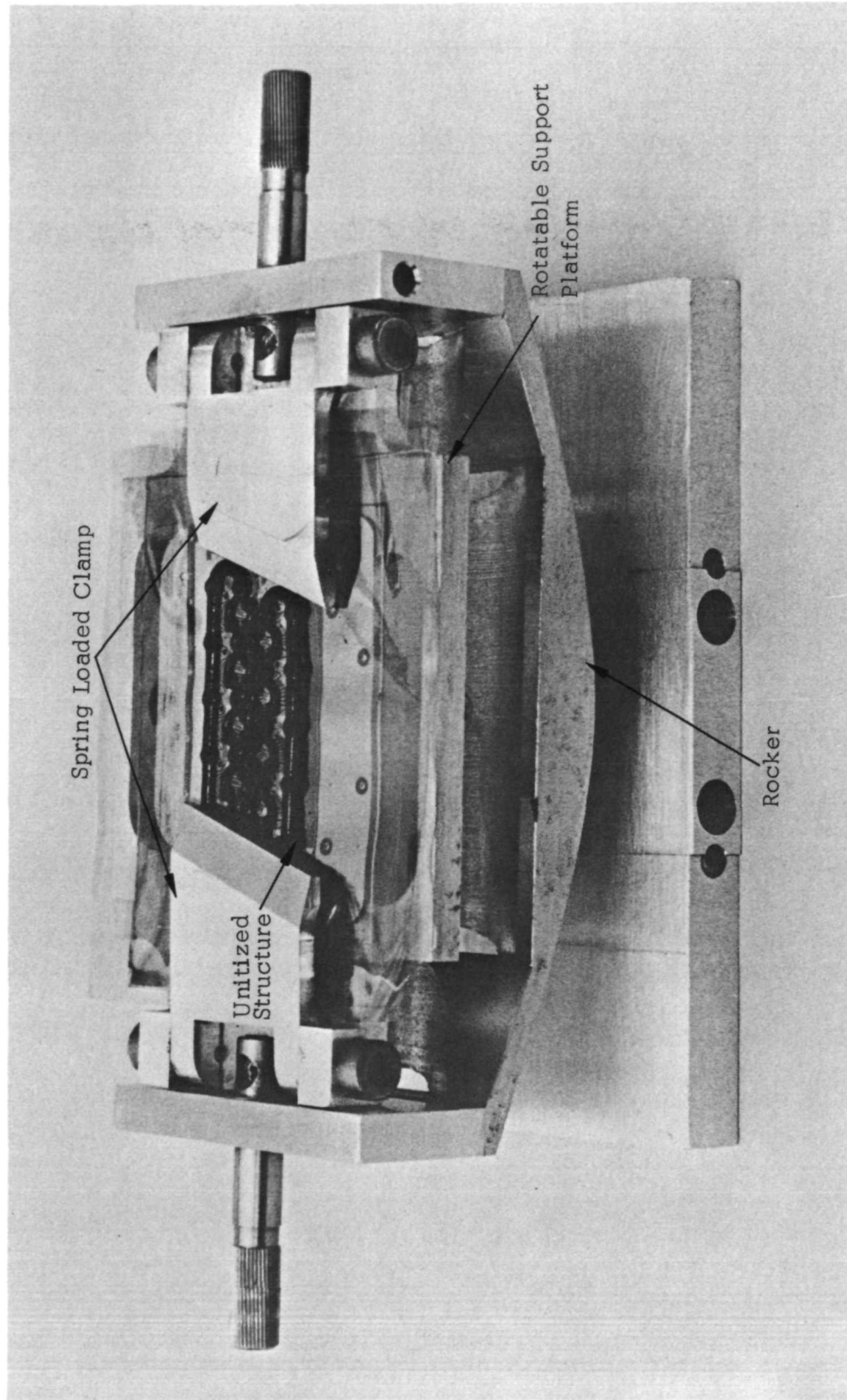

Fig. 6 Circuit Support Fixture

displacement of the joy stick from the neutral position determines the speed of travel. The pushbuttons are wired to prevent accidental lowering of the needle, which could damage the needle or the insulation, by requiring that both pushbuttons are to be depressed to lower the writing needle while depressing only one pushbutton raises it.

The commercially available parts used in the mechanized writing head system are given in Table 2. An assembly drawing and the drawings for fabricated parts are given in Appendix A. The wiring diagram for the mechanized writing head is given in Appendix B.

Table 2 Commercial Parts for Mechanized Writing Head

1 Velmex [*]	Precision Lead Screw Unislide	Model A 4009 P40
1 Velmex	Screw Motion Unislide	Model A 2504 C
1 Velmex	Screw Motion Unislide	Model A 1503 C
1 Velmex	Adaptor Plate	Model A 2500 XZ
1 Barber-Coleman ^{**}	Permanent Magnet Motor	Type BYLM 42800-50
1 Barber-Coleman	Gearhead	Type BYLH 917-2
2 Bodine ^{***}	Gear Motors	Type NSH-11D3; Drive Model 530
2 Bodine	Speed Controls	Model 901
1 Lovejoy ^{****}	Flexible Coupler	Type L-0505
1 Lovejoy	Flexible Coupler	Type L-035

^{*}Velmex, Inc., Malcomb, N.Y.

^{**}Barber-Coleman Co., Rockford, Illinois

^{***}Bodine Electric Co., Chicago, Illinois

^{****}Lovejoy, Inc., River Forest, Illinois

The writing head consists of three parts: the writing tip, a needle, and a reservoir. The writing tips are made by drawing glass tubing down to an 80 μm O.D. with a 25 μm I.D. The tip is then bonded with epoxy to a No. 22G1 hypodermic needle^{*}. The use of a hypodermic needle provides a means for handling the writing tips and also provides a quick and easy method of connecting the writing tips to the reservoir containing the gold resinate. The reservoir is a syringe^{**} that has been modified^{***} to be operated pneumatically to force the gold resinate out through the writing tip, at a rate dependent upon the value of the air pressure applied. For writing lines approximately 150 μm wide at rates of 6 mm per minute to 25 mm per minute, air pressures between $3 \cdot 10^3$ newtons per m^2 and $20 \cdot 10^3$ newtons per m^2 are typically required.

A foot-actuated valve is used to start and stop the writing. A sketch showing the details of the writing head construction is shown in Fig. 7.

The process for forming the coupling loops using the mechanized writing head consists of three steps: (1) The pattern shown in Fig. 8(a) is drawn on the top surface of a unitized, insulated structure with gold resinate; (2) after completing the pattern on the top surface, the structure is turned over and the pattern shown in Fig. 8(b) is drawn on the bottom surface of the structure; and (3) the connecting lines joining the top and bottom patterns are drawn through the apertures and on the outside surfaces of the structure.

*Yale Hypodermic Needle, Type 22G1 with Luer-Lok Hub. Becton, Dickinson & Co., Rutherford, New Jersey

**Tomac Disposable Syringe, 3 cc size, Catalogue No. 15108-25D, American Hospital Supply Div. of AMCS, Evanston, Illinois

***The open end of the syringe is threaded with a 1/8 NPTF pipe thread and fitted with a Grey-Tec Type 2202, Grey-Tec to NPTF fitting (Grey-Tec, Inc., Los Altos, Calif.).

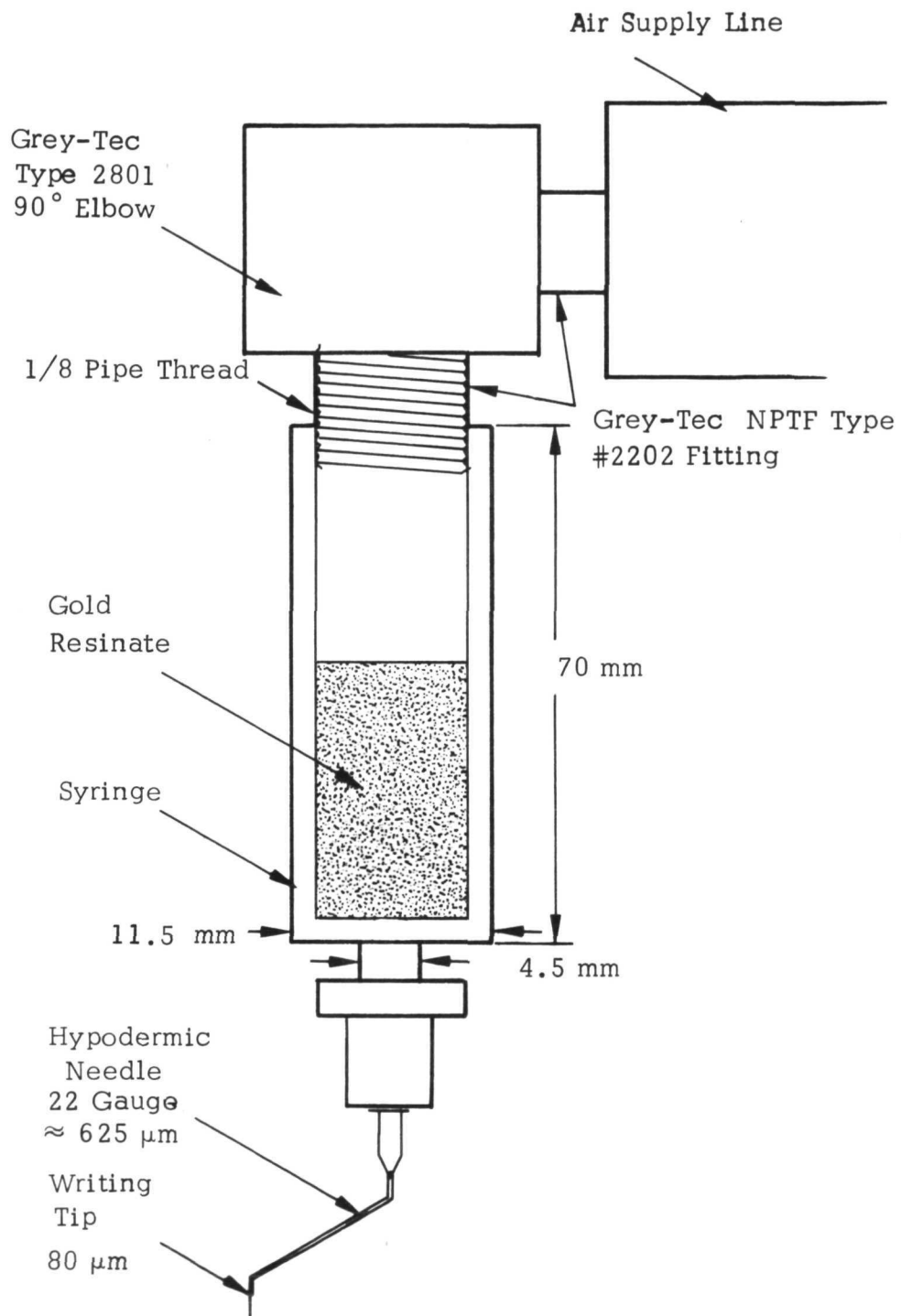

Fig. 7 Writing Head Construction

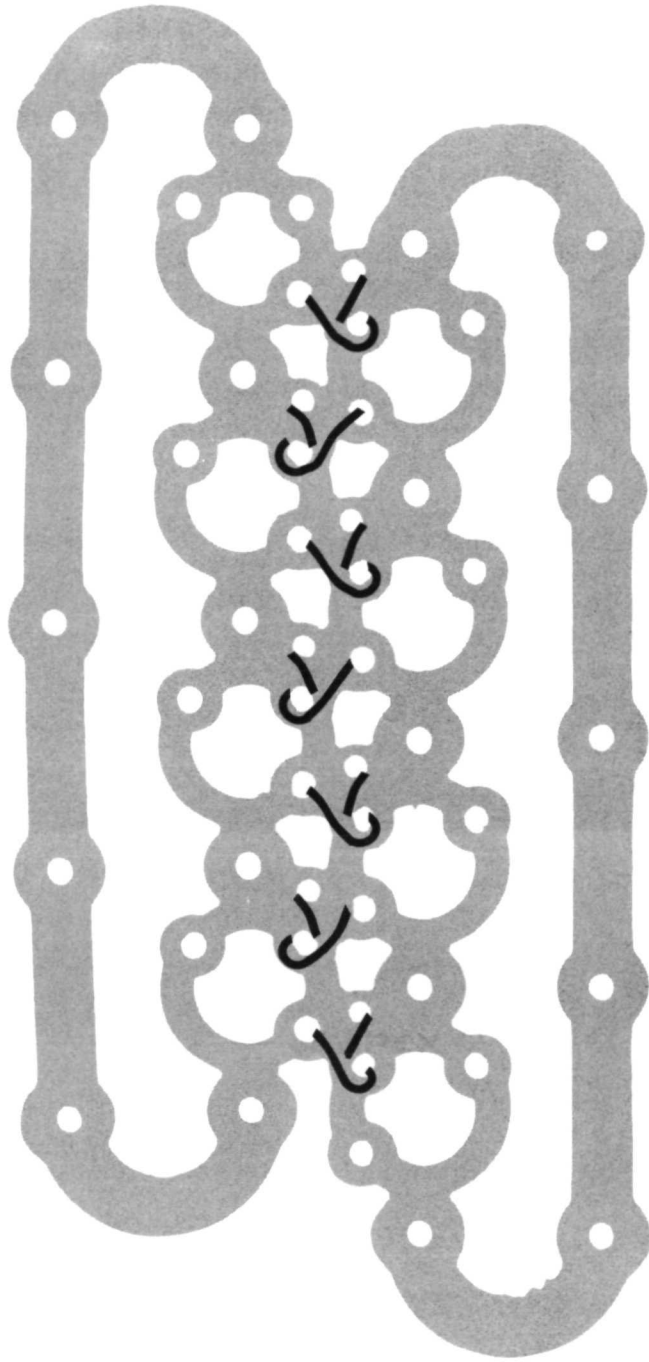

Fig. 8(a) Coupling Loop Etching Pattern, Top

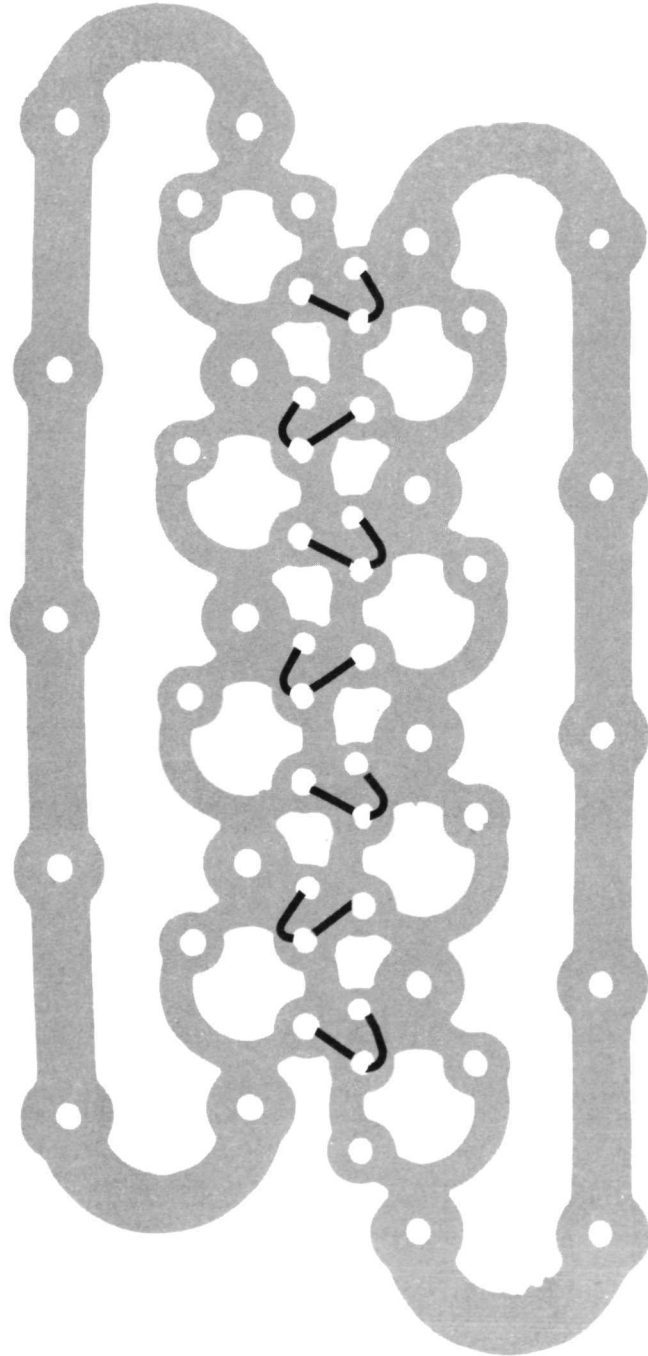

Fig. 8(b) Coupling Loop Etching Pattern, Bottom

Engelhard Type 8119 Squeegee Bright Gold, a gold resinate, is used unmodified for writing the patterns. It has characteristics ideally suited for use in the writing head. Due to the thixotropic nature of the gold resinate paste, fine lines, 70 μm wide, which do not spread after writing are easily formed. The paste does not separate into its components when stored in the syringe for several days, nor does it clog the writing tip, and good adhesion to Pyre ML is obtained.

After the coupling loop pattern is completely written, the gold resinate is dried by heating to 420°K for one hour and cured by baking at 570°K for four hours making the pattern conductive. The coupling loops are completed by copper plating to a thickness of 100 μm . Figure 9 shows the plated coupling loops on a unitized structure with a conductor connecting the loops together for plating.

The structure is given a final insulation coating to insulate the coupling loops by the process described above for the first insulation coating.

A flow diagram showing an automated process for applying coupling loops based on the three-dimensional writing head is shown in Fig. 10.

Structures for use in this process should have smooth, flat surfaces and be mounted with the surface to be written on parallel to the table.

Surface variations which occur with the present state of development of the insulation process would require z direction movement of the writing needle to maintain the spacing required to write continuous conductors. Temporarily, this spacing would be under manual control of the operator. Improvements in the insulating process, which may reasonably be expected to be achieved, will provide the degree of surface flatness that would maintain the required spacing without correction of the z dimension position during writing. Similarly, the surface irregularities produced in the present insulation

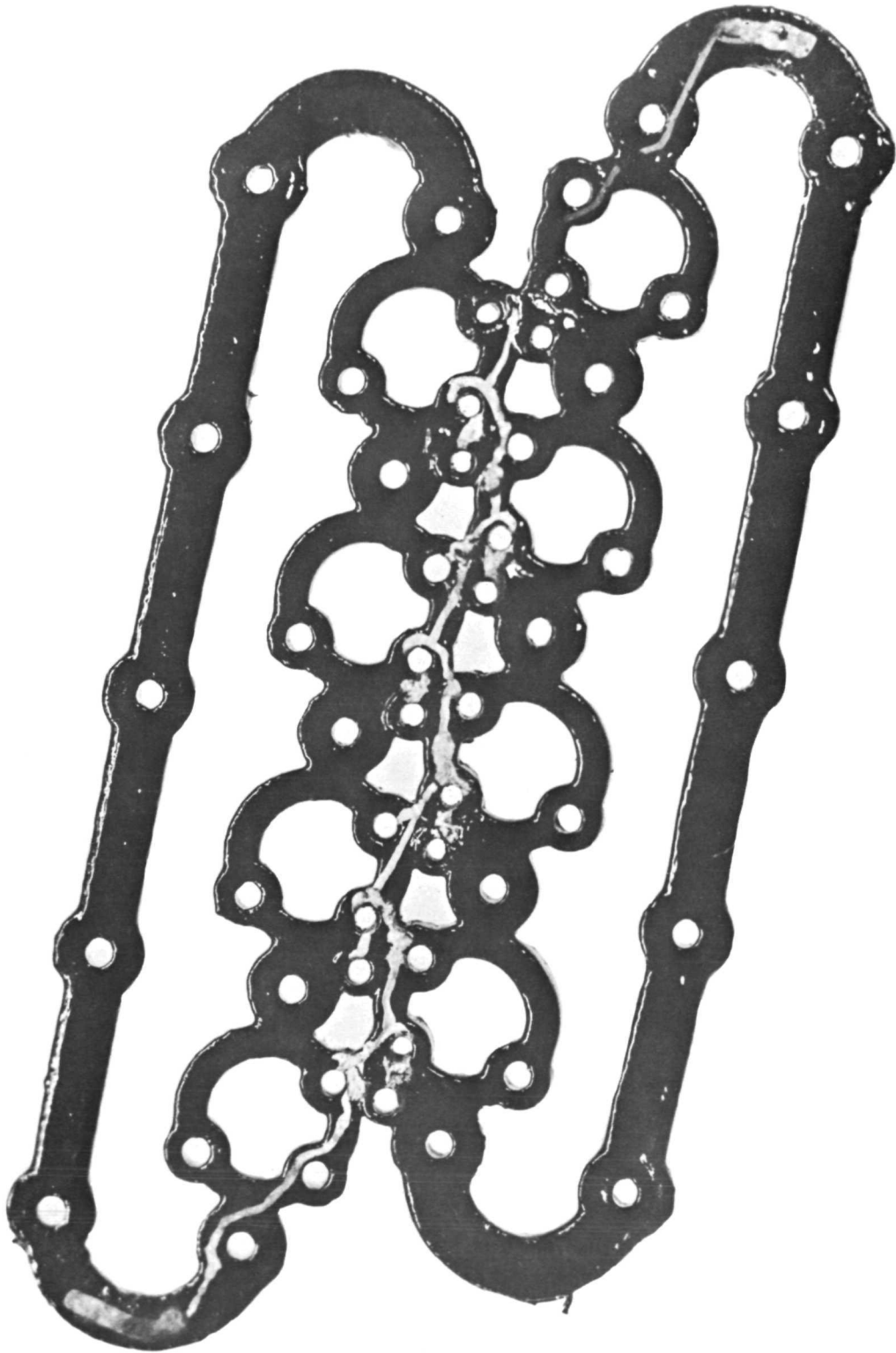

Fig. 9 Unitized Structure with Plated Coupling Loops

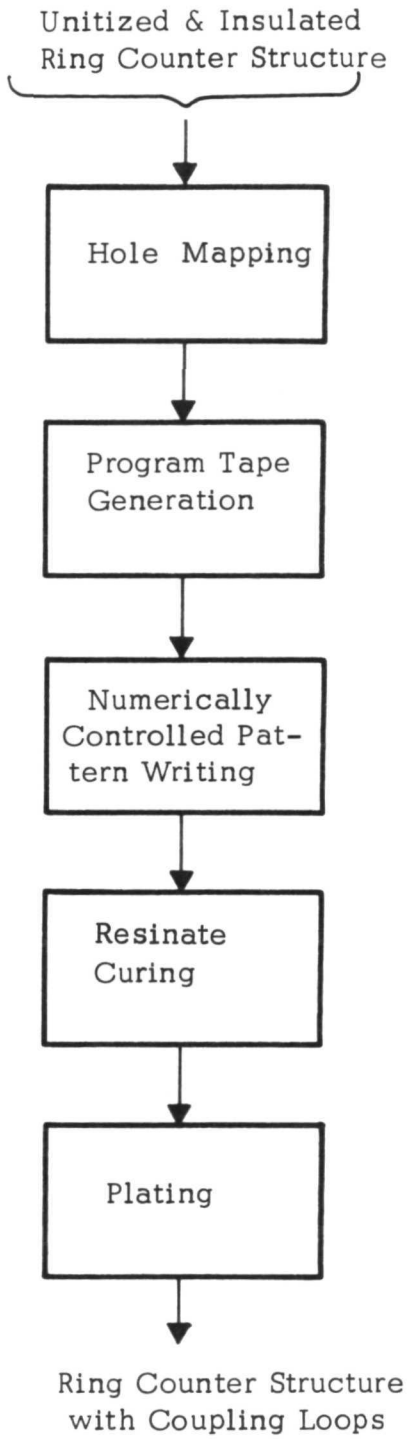

Fig. 10 Flow Diagram of Automated Process for Applying Coupling Loops

process would require manual tilting of the needle for writing on the vertical surfaces. Each vertical conductor would be classified into one of four groups such that within each group one orientation of the needle would enable all conductors within that group to be written. All conductors within a group would be written before changing the orientation of the needle to that for the next group. The expected improvements in the insulating process would result in smooth vertical surfaces, which would also eliminate the necessity of special orientation of the needle for writing vertical conductors.

The hole locations of a unitized and insulated structure are mapped using an Acra-Cord hole-center locator^{*}. A punched paper tape containing the coordinate location of all holes is semiautomatically generated by this machine. This tape is fed into a computer containing a program describing the coupling loop pattern. A tape is generated for the control of a numerical control unit such as a Slo-Syn^{**} NCC351 for control of a Slo-Syn numerical positioning table NCP 1012T5. This tape is used to control the drawing of the coupling loop patterns with the writing head mounted above the numerical positioning table as shown in Fig. 11. Upon completion of the writing, the gold resinate pattern is dried and cured, and in the final step the pattern is copper-plated to form joint-free coupling loops of the desired thickness.

* Mechanical Technology, Inc., Boice Div., Hyde Park, N.Y.

** Superior Electric Co., Bristol, Conn.

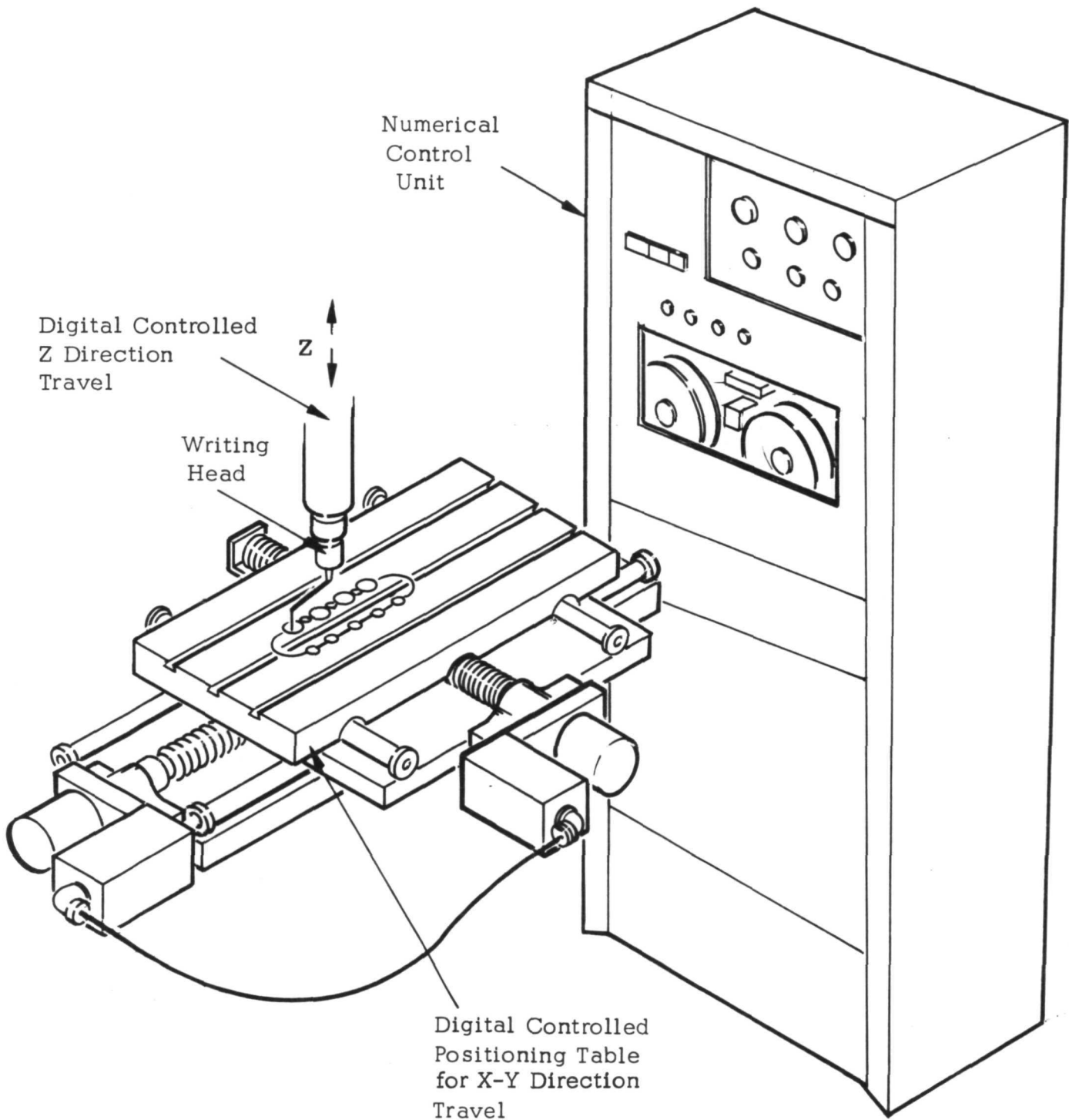

Fig. 11 Automated Writing Configuration

5.0 DRIVE CONDUCTOR PROCESS

As originally conceived, the automated or mechanized writing head was to be used for applying the drive conductor patterns to Pyre ML sheets formed with a hole pattern to match the aperture locations of unitized structures and bonded to the bottom of the structures. With the finding that Kapton, a polyimide material with characteristics comparable to those of Pyre ML and available in sheet form from E.I. duPont, was capable of being metallized and etched to close tolerances, the preparation of the major portion of the drive conductor pattern by a photolithographic process was initiated. This left only the drawing of the conductor patterns through the apertures, across the top of the structure and down the outside surface to be completed with the mechanized writing head. A flow diagram showing the conductor process is shown in Fig. 12. The lines marked A_1 through A_3 trace the sequence of steps for applying the coupling loop conductors. The B_1 through B_3 lines trace the path for applying the drive conductors.

The preparation of the drive conductor sheets by a photolithographic process starts with the preparation of Kapton sheets having metallization on both sides. Drive conductor sheets have been made using commercially available gold coated Kapton sheets from AGC Incorporated* where the gold was applied by coating with a gold resinate ink. This film was found, however, to have insufficient adhesion which resulted in a number

* AGC, Inc., Meriden, Connecticut.

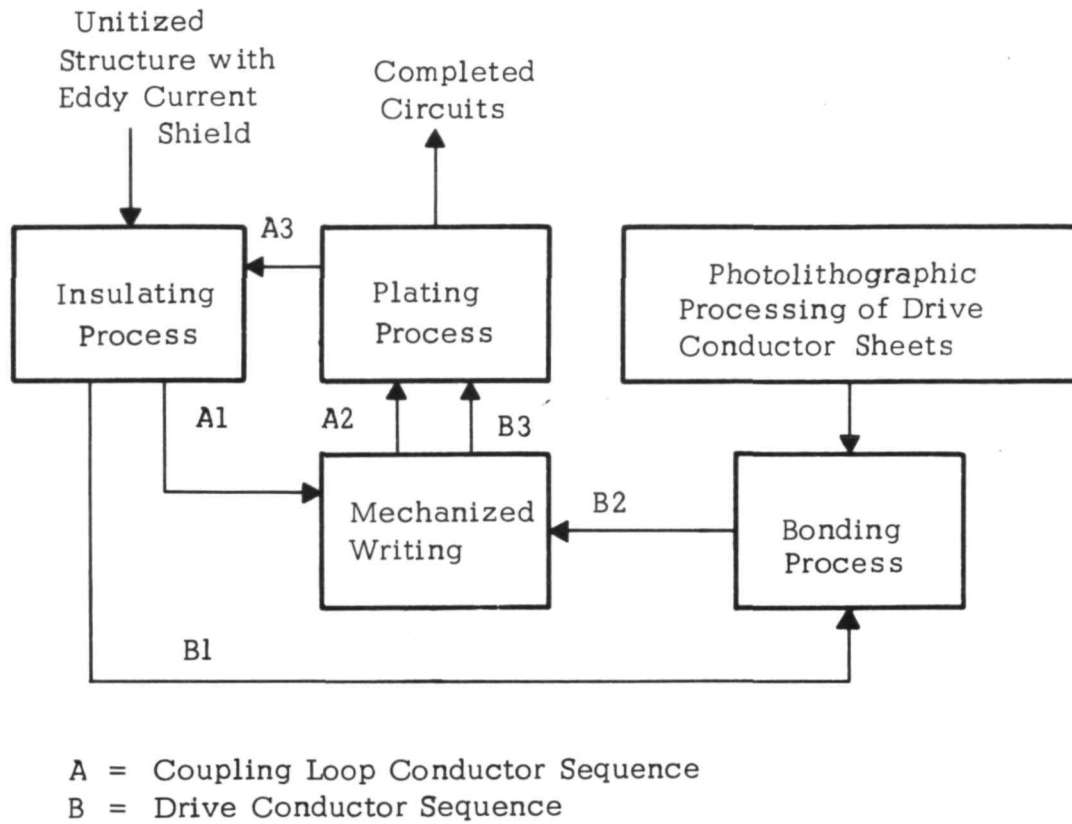

Fig. 12 Flow Diagram for Conductor Processes

of broken conductor lines before plating. Gold coated Kapton has been successfully prepared at Ampex by evaporation. To obtain good adhesion, a layer of nichrome approximately 1200 Angstrom units thick is deposited prior to a 900 Angstrom thick deposit of gold. This is followed by a second layer of nichrome and gold to minimize pinholes. The second side receives the same set of evaporations. The thickness of the gold is increased to approximately 1.5 μm by plating in an Orotemp^{*} plating bath at a current density of 11 amperes per square meter.

The use of copper metallization on Kapton was investigated as an alternative to the gold metallization because the bond between copper and Kapton is stronger and the bonding process is simpler. To be able to use copper metallization, the bonding of the etched conductor sheet to the structure must occur after the curing of the gold resinate pattern written in the structure. This sequence of steps is required because the temperature used to cure the gold resinate causes oxidation of the copper.

The two problems with this approach are: the commercially available Kapton sheets with copper metallization are available with metallization on one side only, and low curing temperature inks suitable for making connections between the conductors on the structure and on the Kapton sheet are silver rather than gold based, which would create the potential of silver migration.

The next step in the photolithographic process is the preparation of the photomasters. A 1:1 contact print of the unitized structure is made first and then enlarged to 10X. Using this enlargement, a 10X layout of the hole pattern to be etched in the Kapton is made. This is shown in Fig. 13. Two additional 10X patterns are made, one of the top side of the drive con-

*Technic, Inc., Providence, Rhode Island.

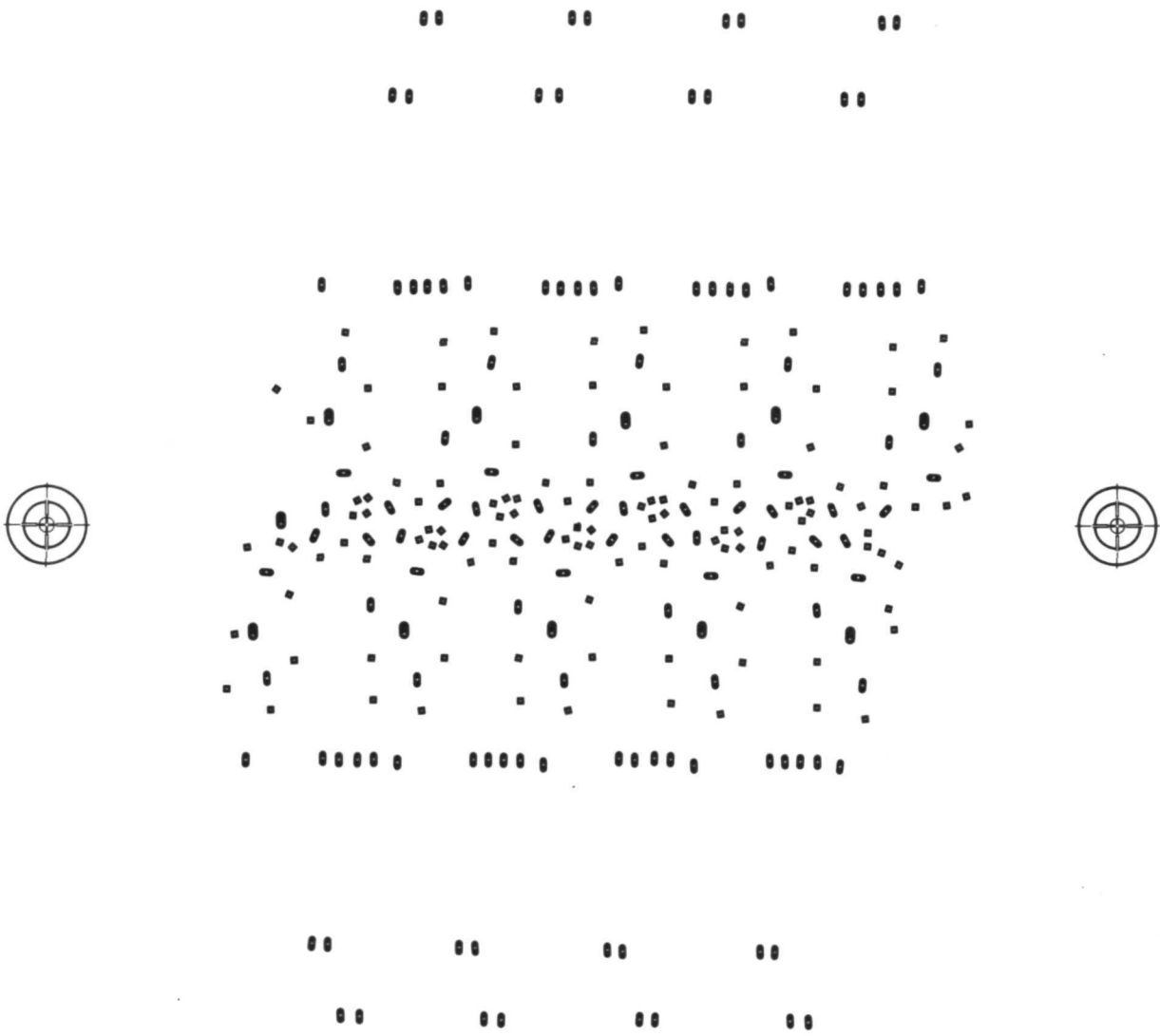

Fig. 13 Hole Etching Pattern for Drive Conductor Sheet

ductor sheet and the other of the bottom side of the drive conductor sheet. These patterns are shown in Figs. 14 and 15. The 10X patterns are reduced to form positive and negative etching masters, as required by whether a positive or negative resist is used for exposure. Two basic processes for etching the holes in the Kapton sheet have been used. In one KPR* (Kodak Photo Resist), a negative photoresist, was used to coat both sides of the metallized film. Both sides were exposed through the hole pattern photo-master and the image was developed. The gold was first etched away by immersing the exposed sheet in C-35** , a gold etchant, for 5 minutes at room temperature. The Kapton was then etched for four minutes in a 65% solution of sodium hydroxide heated to 363° -368°K. The KPR was then removed by immersion in SS Stripper*** followed by immersion in hot NMP (N-Methyl-2-Pyrrolidone). This process has been used to etch holes in Kapton both before and after etching the conductor pattern. The success of the stripping of the KPR is directly related to the coating process. The coating process which has allowed the KPR to be stripped by the above described process and still provide the necessary resistance to the hot hydroxide is to draw-coat with KPR, bake for 15 minutes at 390°K, draw-coat a second time followed by a second 15 minute bake at 390°K. This was the process used with the AGC Kapton sheets, which were too porous to provide the masking required by the second process.

The second process for etching the hole pattern in the Kapton sheets makes use of the metallization as the mask for etching. Gold and copper coatings are equally suitable for masking, provided they are

* Eastman Kodak Corp., Rochester, N.Y.

** Film Microelectronics, Inc., Burlington, Mass.

*** Graphic Arts Supplies & Equipment, Los Angeles, Calif.

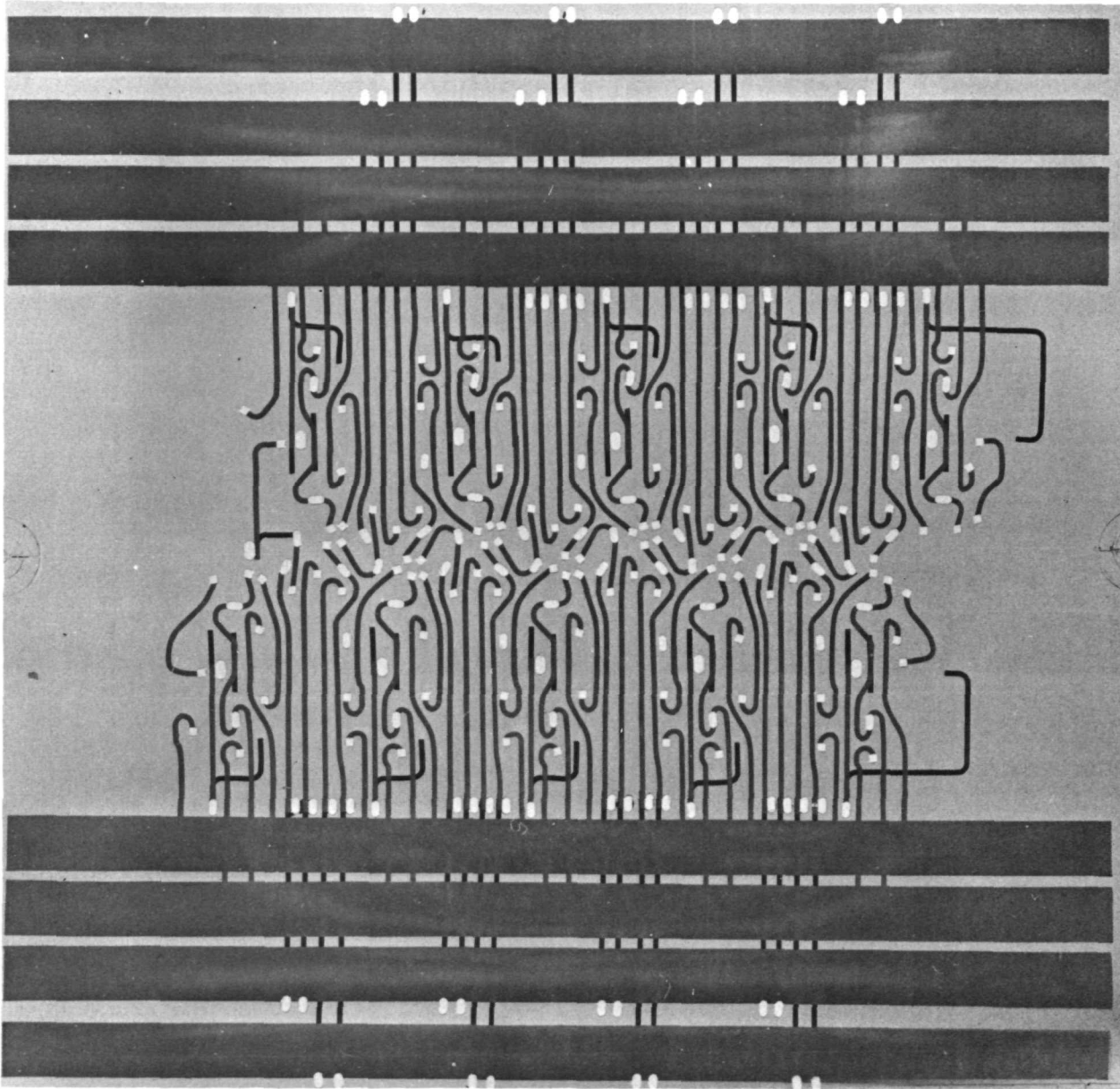

Fig. 14 Etching Pattern: Top Side of Drive Conductor Sheet

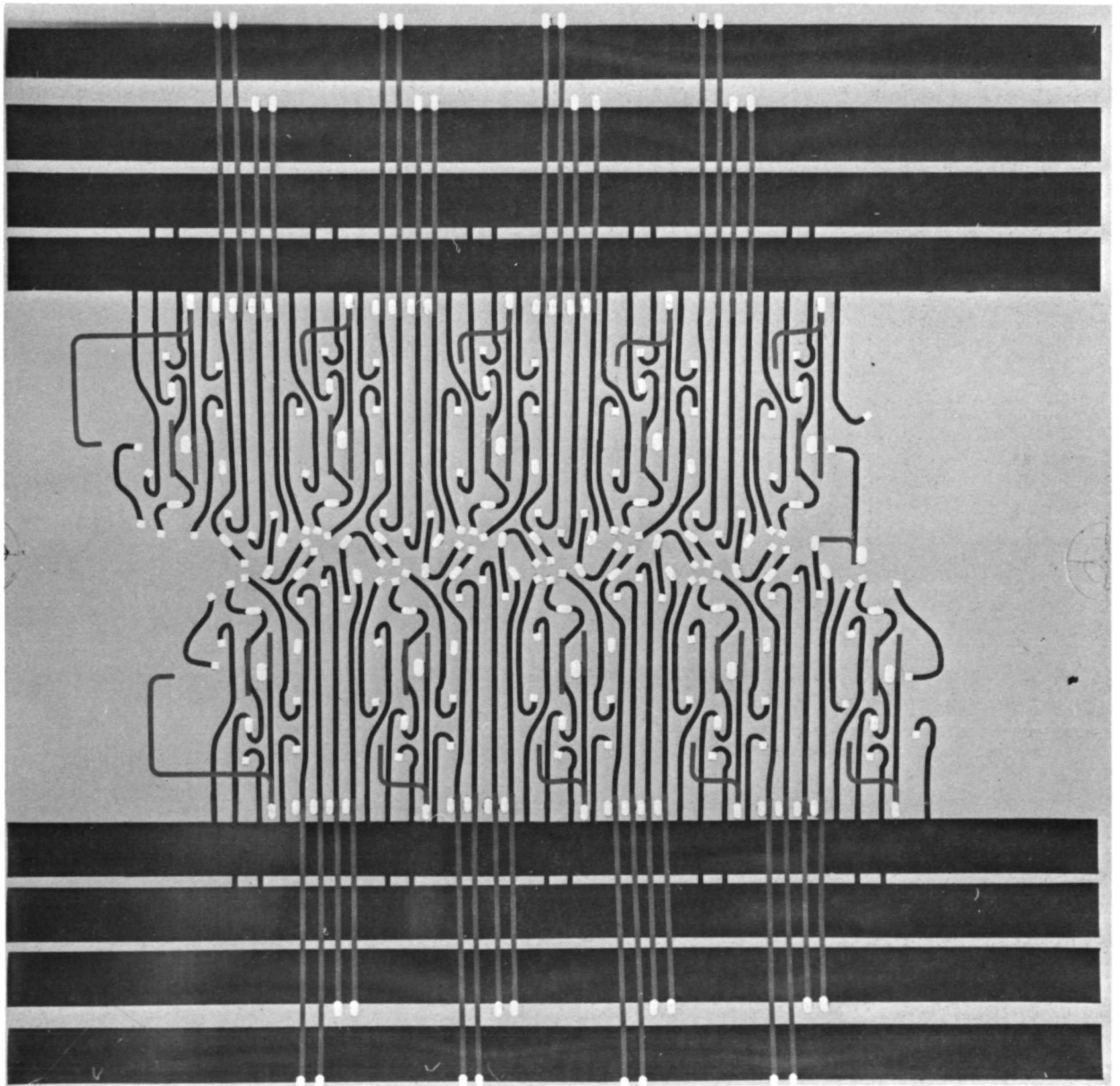

Fig. 15 Etching Pattern: Bottom Side of Drive Conductor Sheet

nonporous. The film is draw-coated with Shipley Type AZ 1350H^{*}, positive photoresist, and dried in a 10 minute bake at 390°K. Both sides of the film are exposed through a negative photomaster. The resist is then developed and the gold is etched with C-35 as described above (for copper metallization a FeCl₃ solution would be used) after which the resist is stripped with acetone. The hole pattern in the Kapton sheet exposed by the metal mask is etched as in the first process. This process has the advantage of not requiring the use of KPR and the resultant difficulty in stripping it off.

The etching of the conductor pattern follows the process steps described above for the Shipley resist with the difference that the positive photomaster is used for the conductor pattern, rather than the negative photomaster used for the hole pattern.

The photolithographic process is also used to prepare a Kapton gasket which has the same shape as the outline of the unitized structure. The gasket contains that portion of the conductor pattern required to complete the turns across the top of the structure.

Upon the completion of the processing of the drive conductor sheet and the gasket, these two items are attached to the structure with a polyimide type adhesive, Thermo Resist TR 150-25. To prevent the Thermo Resist from covering the conductors during the bonding step, Kapton sheets are temporarily bonded to the top of the gasket and to the bottom of the drive conductor sheet with Elmer's Glue.^{**}

*Azoplate Corp., Murray Hill, N. J.

**Borden Chemical Co., New York, N.Y.

The Thermo Resist is contact transferred to the top of the structure from a sheet containing a 100 μm thick layer of Thermo Resist applied with a doctor blade. First the gasket is aligned and attached to the top of the structure. The Thermo Resist is dried by placing the structure in an oven at 360°K for 1 hour under a pressure of approximately $5 \cdot 10^3$ newtons/m². Next, the Thermo Resist is contact transferred to the bottom of the structure. The drive conductor sheet is aligned and attached to the bottom of the structure, and heated for an hour at 360°K to dry the Thermo Resist under the same pressure as used for the gasket. The temperature is then increased to 450°K for 1 hour to cure the Thermo Resist. The drive conductor pattern is completed by writing lines connecting the conductors on the gasket and drive conductor sheet through the apertures and on the sides of the structure. The gold resinate conductor pattern is cured to form gold conductors at 570°K for 1 hour.

Leads are welded to the drive conductor pattern to make electrical connections for the plating. Portions of the gold patterns on the drive conductor sheet, which are not to be plated, are masked with Shipley Resist AZ1350H. The drive conductors are then copper plated to a thickness of 100 μm after which the resist is removed, and the exposed gold is etched with C-35, a selective gold etchant, to remove the shorts in the conductor pattern used to promote uniform plating.

A Kapton sheet containing the end around coupling loop is attached to the structure by welding and plated to a thickness of 100 μm to complete the ring counter circuit.

A unitized structure with a completed drive conductor pattern is shown in Fig. 16. In this circuit up to 4 turns are formed through a 1 mm diameter aperture. The number of turns that can be formed through an aperture is a function of the conductivity requirements for the conductors.

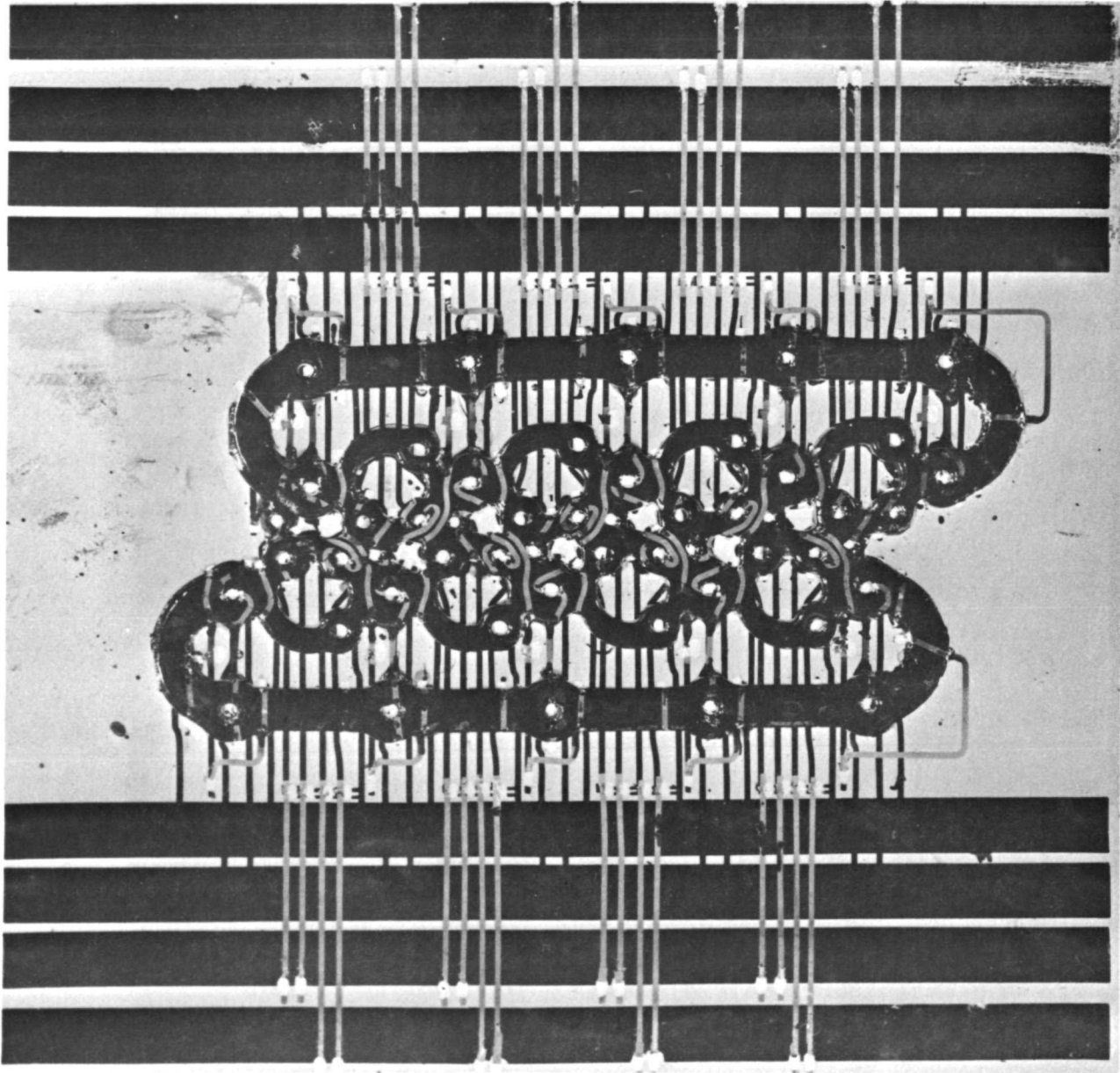

Fig. 16 Unitized Structure with Completed Drive Conductor Pattern

To obtain higher conductivity wider conductors are required and therefore fewer turns are possible. Seven turns have been formed through a 1 -mm aperture using conductors approximately 200 μm wide.

The resistance of the coupling loops formed by this process cannot be measured since the conductors are continuous and form closed loops. However, their resistance has been calculated to be approximately 1.4 milliohms per mm. The resistance of the drive conductors varies from 700 to 70 μohms per mm as the width of these conductors varies from 250 μm to 2.5 mm.

The complete process for fabricating the ring counter circuit is shown in the flow diagram of Fig. 17. The sequence of the process steps indicated by the solid lines traces the automated process. The sequence of process steps indicated by the dashed lines traces the laboratory process used for preparing the ring counter circuits produced under this contract with the mechanized writing head.

The yield of each of the processes has improved with the increased experience gained through repeated use of a process. The estimated yield presently obtained and that expected to be obtained with further development, for each of the processes, is shown in Table 3. The table also indicates the type of tests made to determine acceptance quality. Visual inspection is used in evaluating all of the processes. However, this is augmented with electrical tests where visual tests are inadequate; ie, magnetic characteristics are measured on structures after firing, conductivity tests are made after insulation and continuity tests are made of drive conductors.

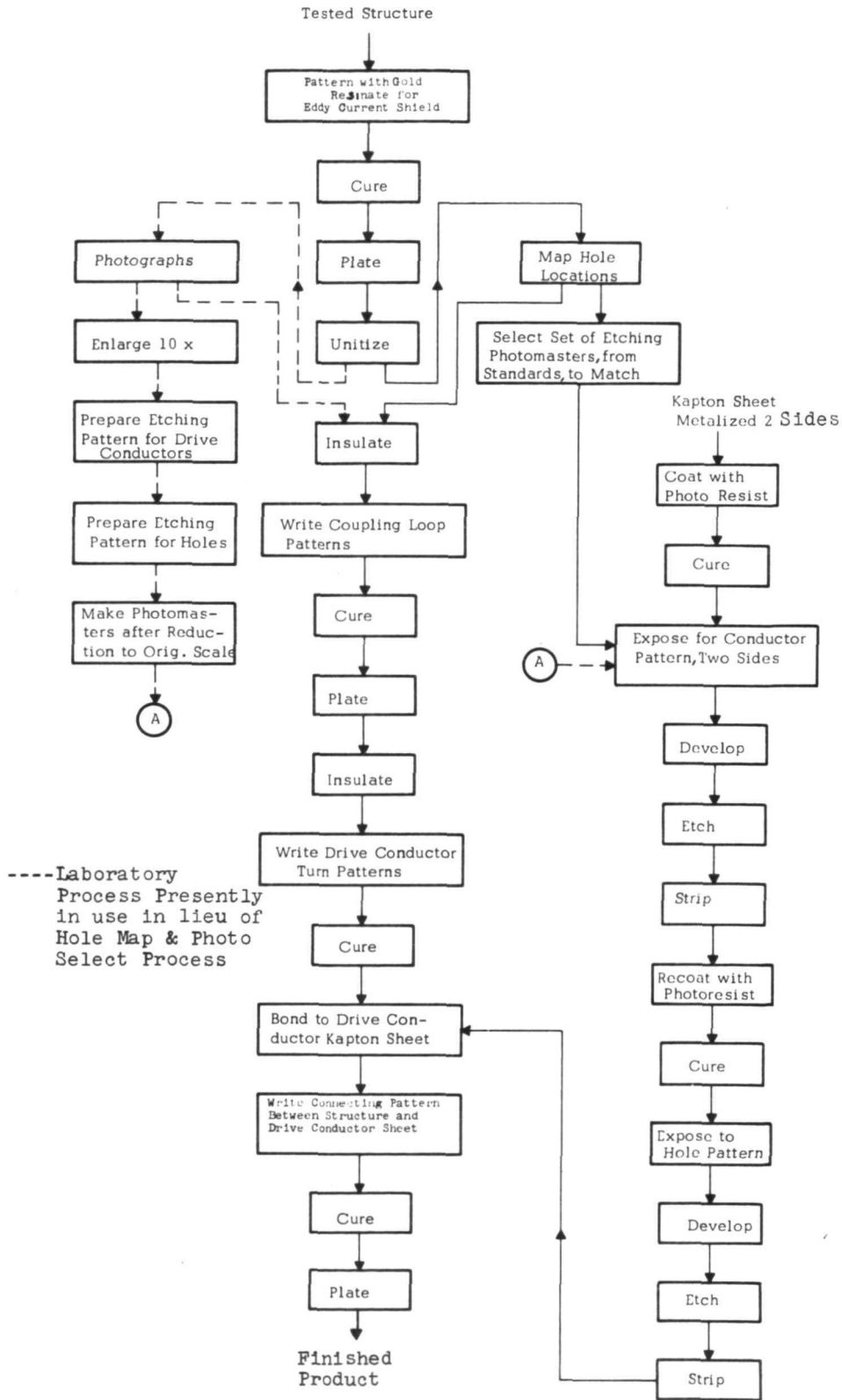

Fig. 17 Detailed Flow Diagram for Complete Magnetic Circuit Processing

Table 3 Yield for Circuit Fabrication Processes

Process	QC Tests (Elect. Visual)	Present Yield (%)	Expected Yield (%)
Molding/Firing Structures	E & V	75	95-100
Eddy Current Shield	V	80	95-100
Unitizing	V	75	95-100
Insulating	E & V	50	60-70
Coupling Loops	V	75	90-100
Drive Conductors	E & V	50	80-90

6.0 CONCLUSIONS AND RECOMMENDATIONS

A mechanized process has been developed for applying joint-free plated conductors to magnetic logic structures that is readily amenable to automation. By using this process, complete magnetic logic circuits "wired" to form eight-stage ring counters have been fabricated which contain no connections between conductors except those made to connect the circuit to the drive sources. The process developed is capable of fabricating increased numbers of interconnected logic circuits to provide more complex logic functions without requiring an increased number of drive source connections. This development significantly raises the reliability obtainable with magnetic logic circuits whose reliability had previously been shown [Ref. 2] to be limited by the number of (inspected) solder joints required to fabricate the circuits. In these circuits the reliability in part will be determined by the reliability of the insulation which is very high for the Pyre ML insulation used, but of the three elements forming the circuits--ferrite structures, copper conductors and insulation --the insulation is the only one which has a known failure mechanism.

Of the processes developed for applying plated conductors to a magnetic logic structure, the insulating process has been identified as having the lowest yield. Also the dimensional variation which occurs in the multistage logic structure results in a significant amount of added processing complexity to obtain drive conductor sheets that match the structures.

To simplify the processing and improve the yield of the process it is recommended that an improved process for insulating the logic structure be developed. It is further recommended that in order to provide circuits

with no known failure mechanisms, this development be aimed at using an inorganic insulating material.

Since the dimensional variation of the multistage logic structures, while small, is sufficient to cause additional complexity in the processing, it is recommended that an investigation be made into the feasibility and advantages of using smaller, possibly single-stage, logic structures.

REFERENCES

- [1] An Wang and Way Dong Woo , "Static Magnetic Storage and Delay Lines," J. Appl. Phys., Vol. 21, p. 49054, Jan. 1950.
- [2] C. H. Heckler and J. A. Baer, "All Magnetic PCM Telemetry: A Review of the System Breadboard," Phase III Report, Contract NAS1-3380, Stanford Research Institute, Menlo Park, California, Oct. 1965; also available as NASA CR-435, April 1966.
- [3] C. H. Heckler and N. C. Bhiwandker, "Development of Magnetic Logic Batch Fabrication Techniques," Final Report, Contract NAS1-7878, Ampex Corporation, Redwood City, Calif.; also available as NASA CR-66890.

APPENDIX A

Drawings for Mechanical Writing Head Parts

* PARTS LIST

1. Bodine Gearmotor, Type NSH-11D3, Drive Model 530
2. Barber Coleman Permanent Magnet Motor, Type BYLM 42800-50
3. Barber Coleman Gearhead, Type BYLH 917-2
4. Velmex Precision Lead Screw Unislide, Model A 4009 P40
5. Velmex Screw Motion Unislide, Model A 2504 C
6. Velmex Screw Motion Unislide, Model A 1503 C
7. Velmex Adapter Plate, Model A 2500 XZ
8. Lovejoy, Flexible Coupler Type L-0505
9. Lovejoy, Flexible Coupler Type L-035
10. Micropositioner, Motor Mounting Plate
11. Micropositioner, Base Plate
12. Micropositioner, Bracket
13. Micropositioner, Block #1
14. Micropositioner, Block #2
15. Micropositioner, Mounting Arm
16. Micropositioner, Mounting Bracket

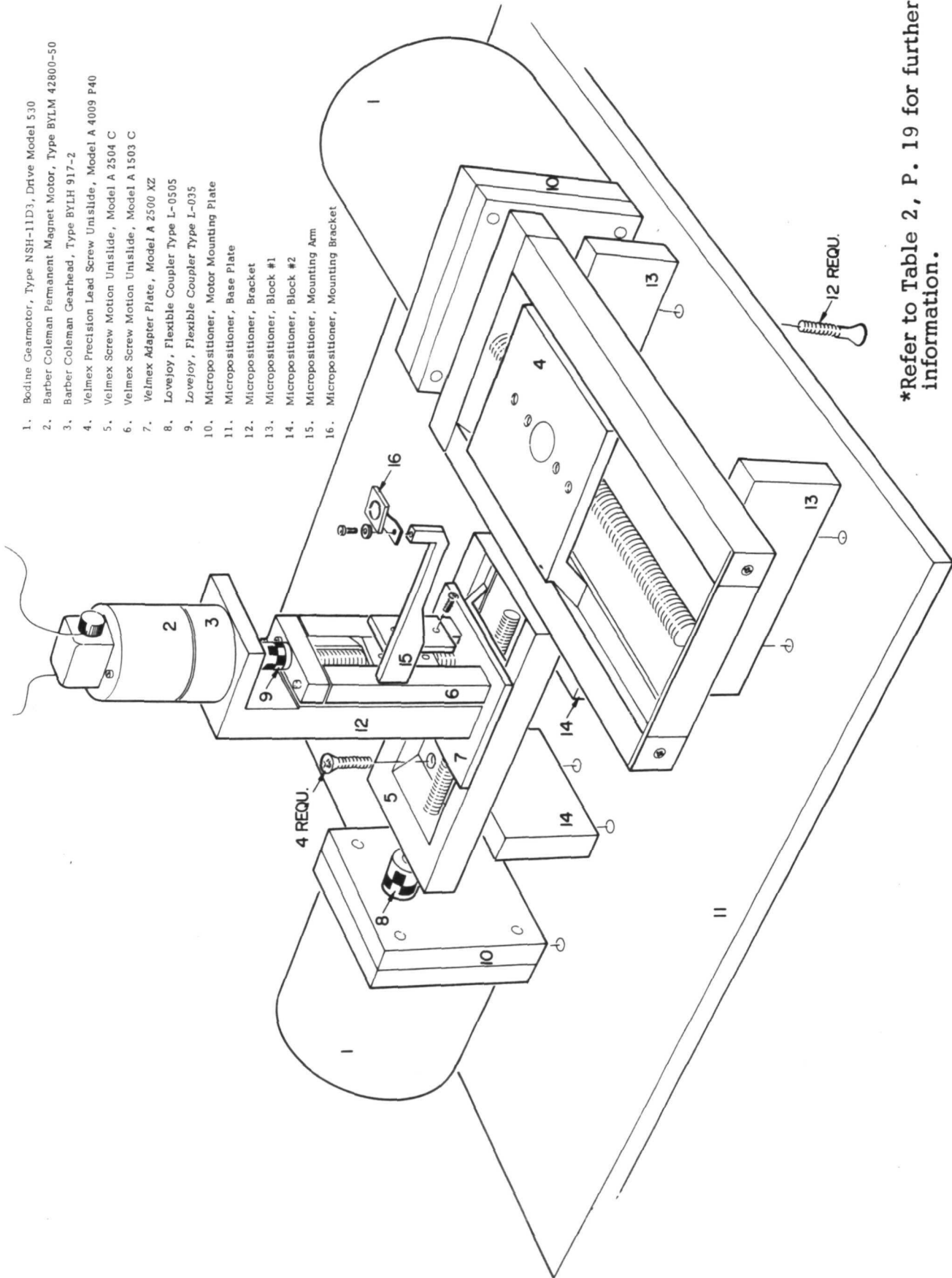

*Refer to Table 2, P. 19 for further information.

Fig. A-1 Assembly Drawing: Mechanized Writing Head

ALL DIMENSIONS IN MILLIMETERS

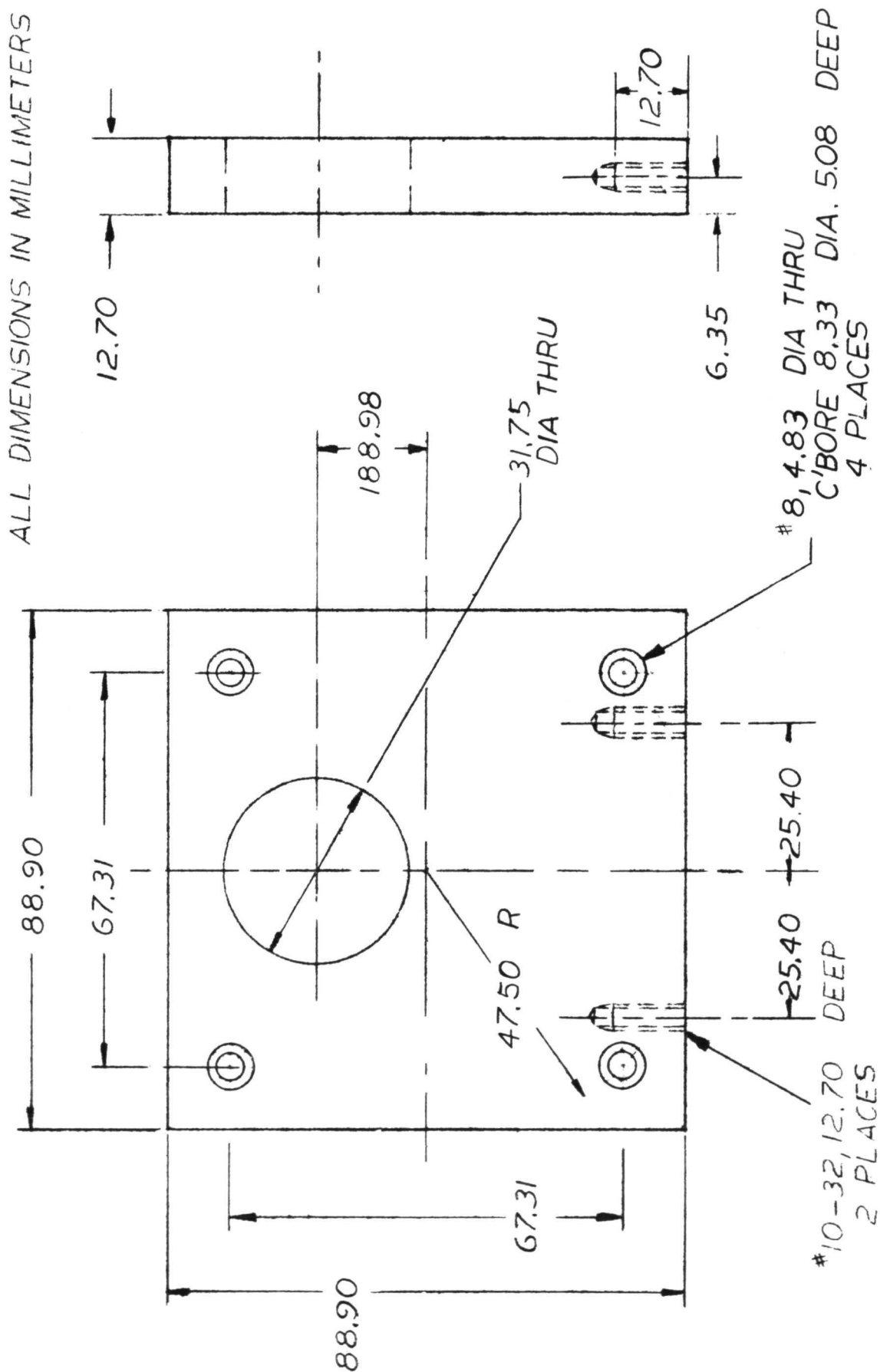

Fig. A-2 Micropositioner, Motor Mounting Plate

ALL DIMENSIONS IN MILLIMETERS

*8 (4.83 DIA) THRU, C'BORE 9.53 DIA
6.35 DEEP 12 PLACES AS SHOWN

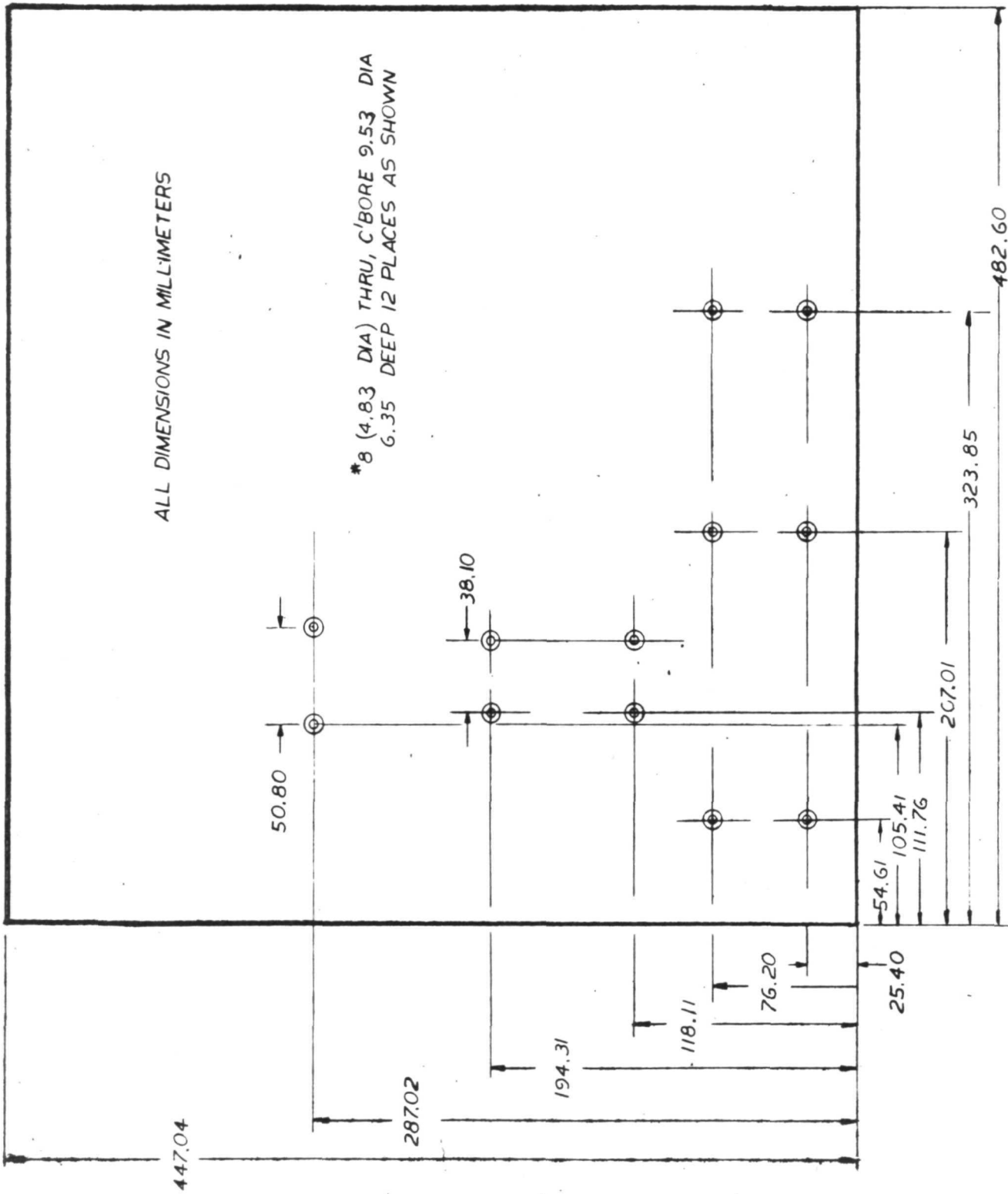

Fig. A-3 Micropositioner, Base Plate

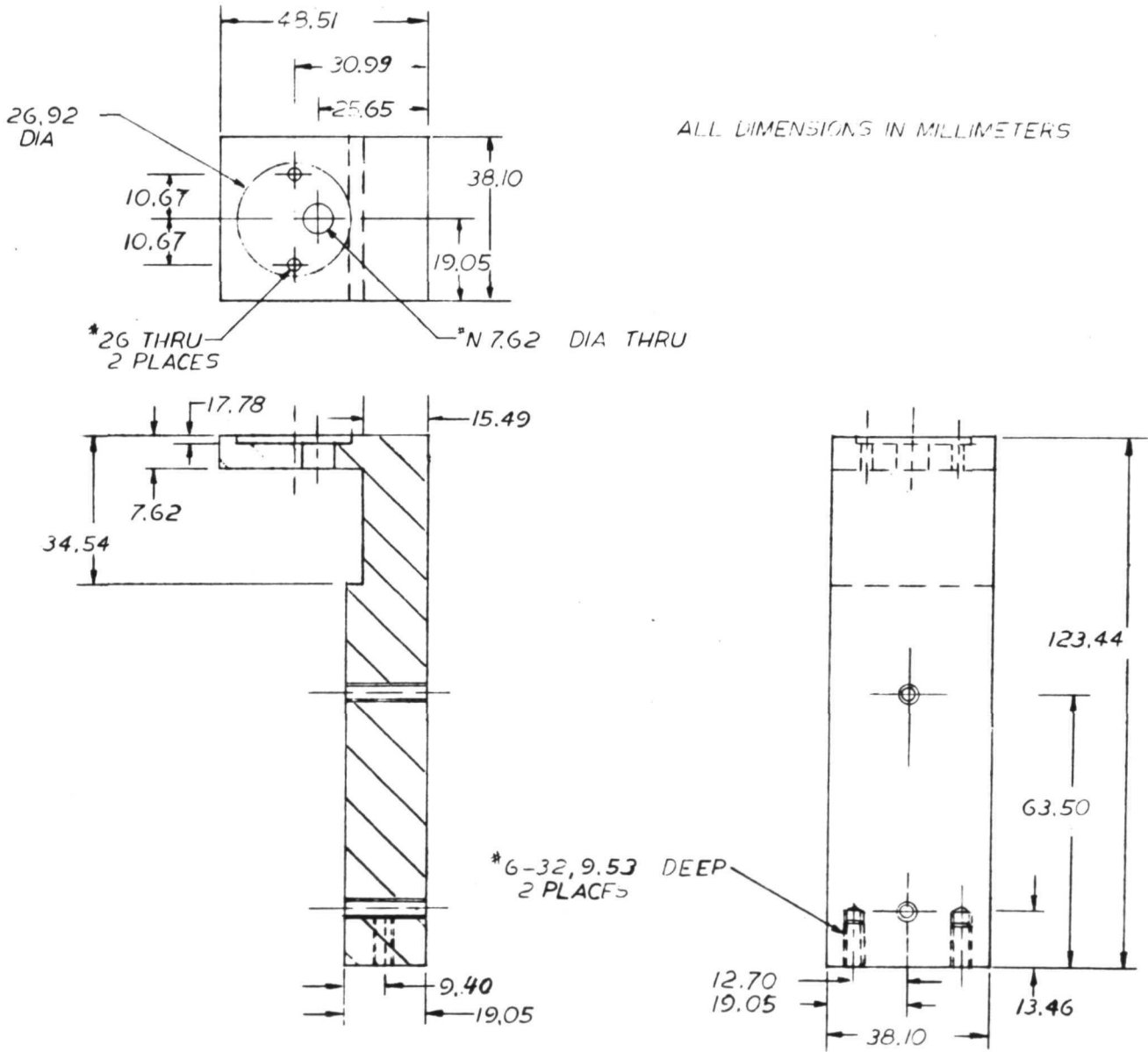
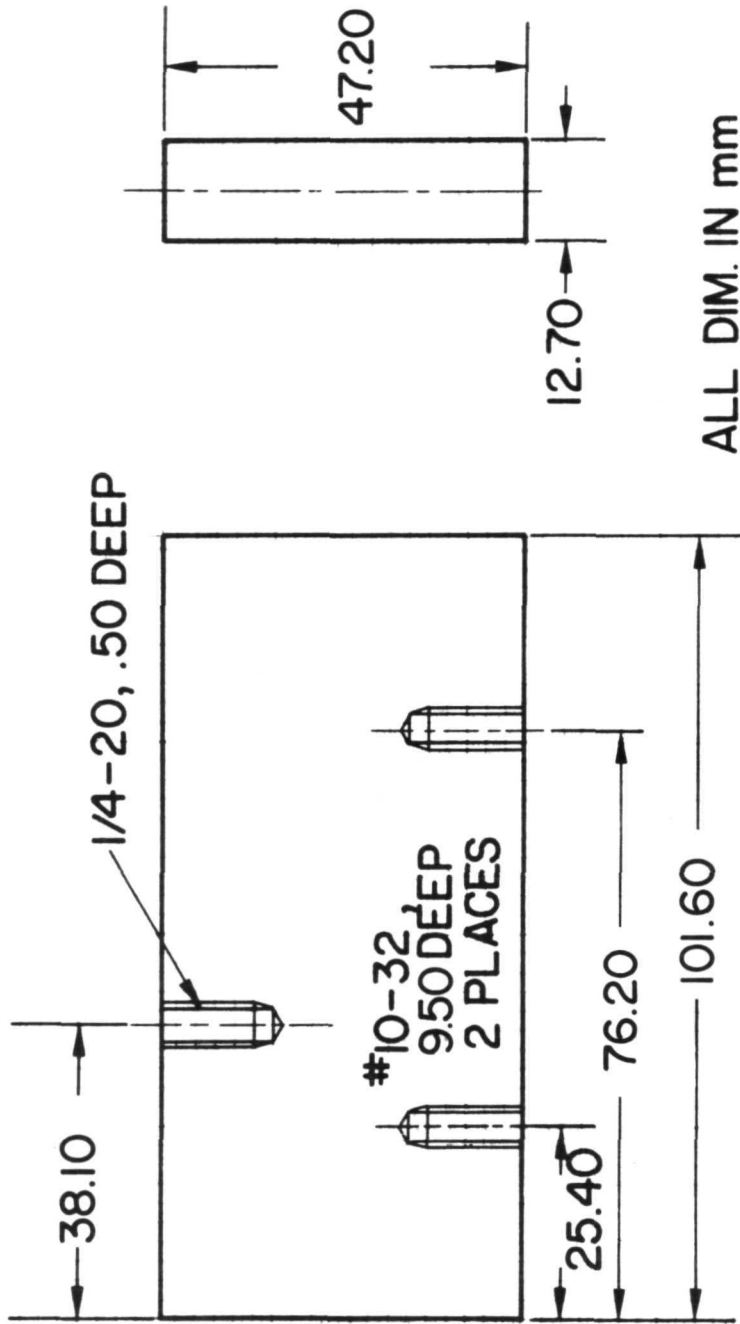

Fig. A-4 Micropositioner, Bracket

MAT'L. : ALUM. 2 REQU.



MICROPOSITIONER, BLOCK # 1

Fig. A-5 Micropositioner, Block #1

MAT'L: ALUM. 2 REQU.

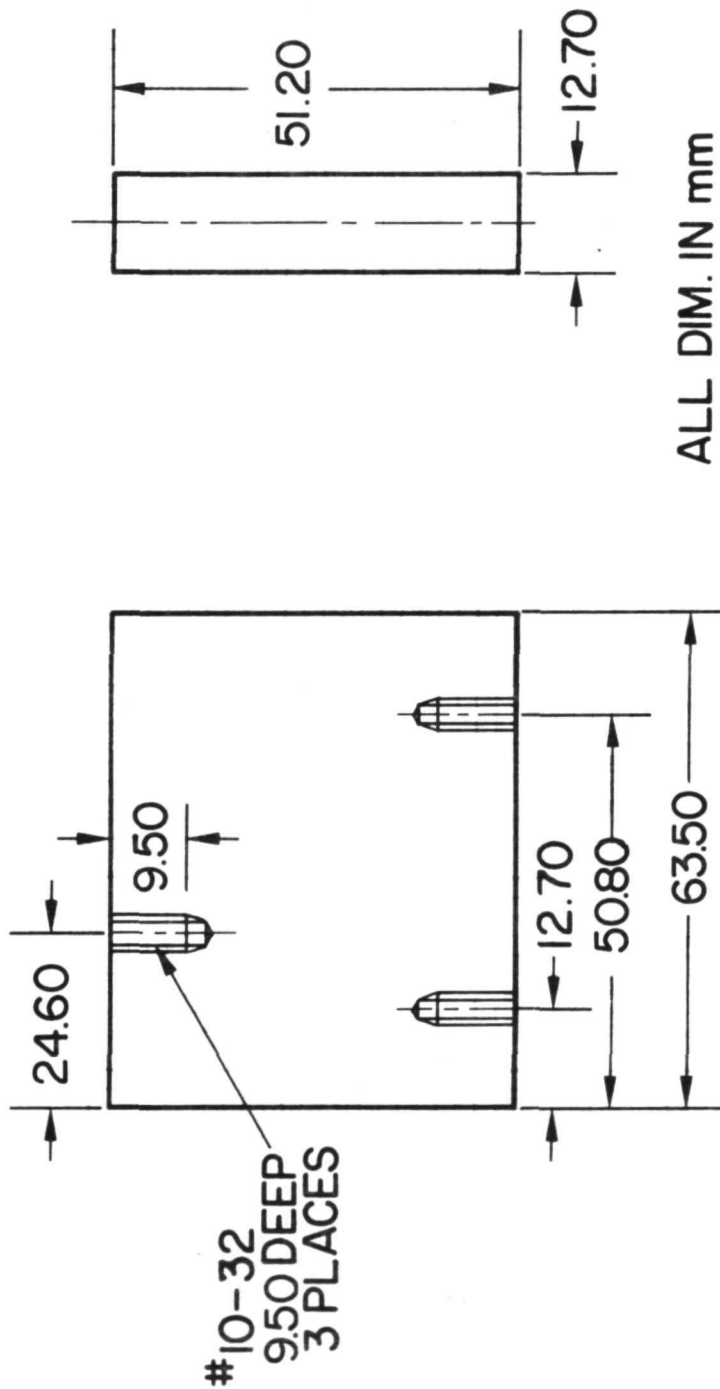

MICROPOSITIONER, BLOCK #2

Fig. A-6 Micropositioner, Block #2

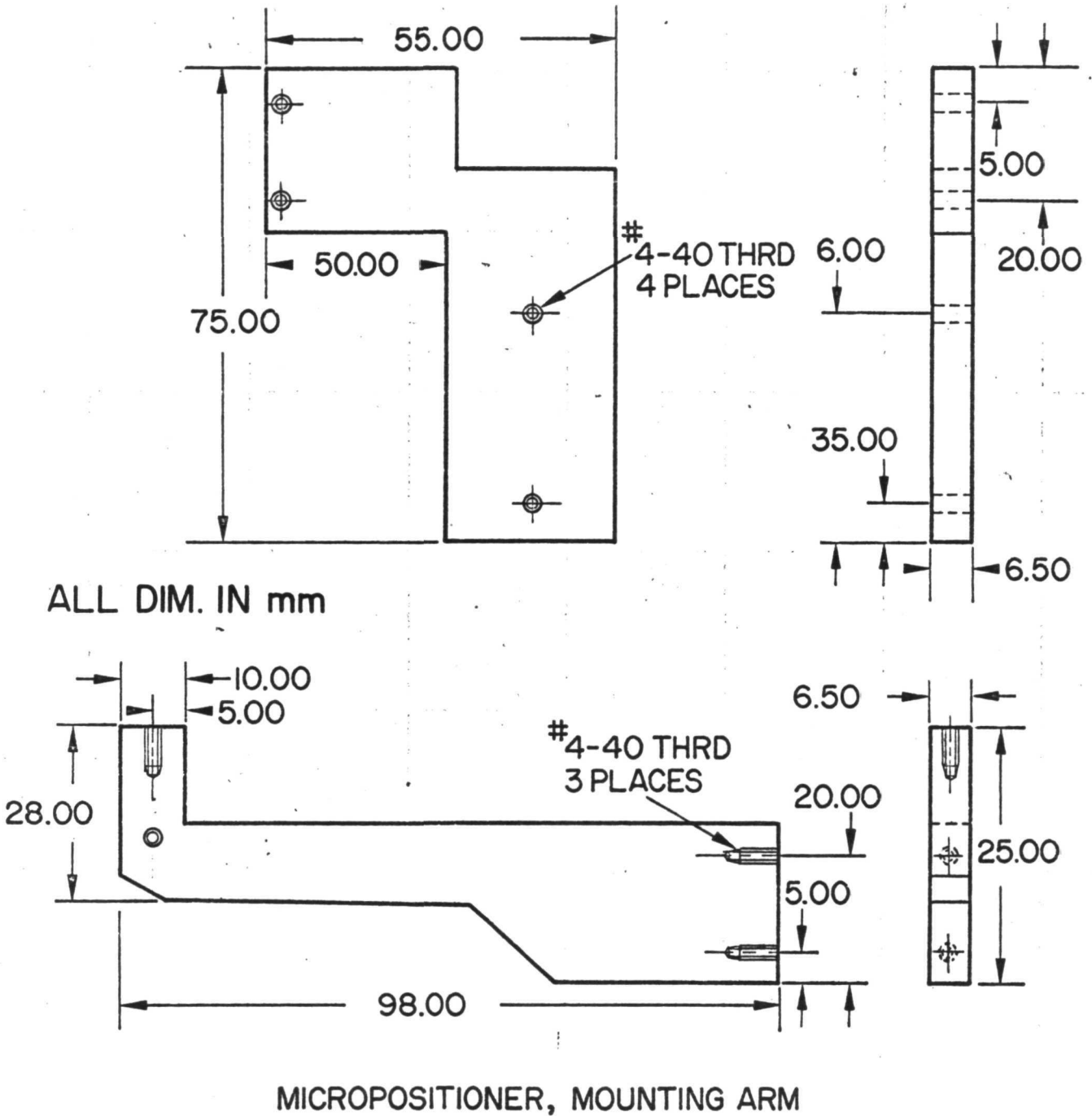
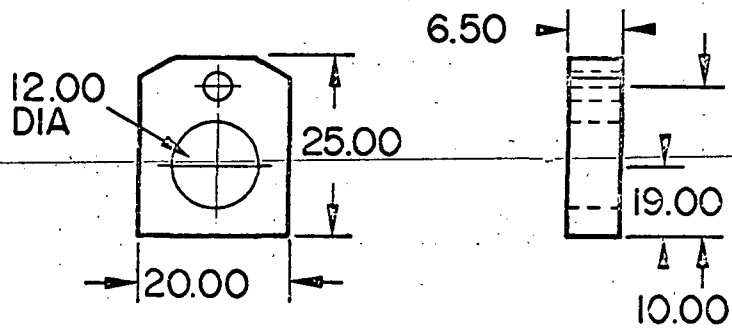
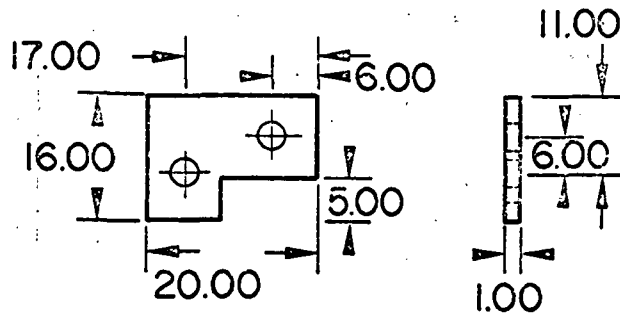

Fig. A-7 Micropositioner, Mounting Arm



ALL DIM. IN mm



MICROPOSITIONER, MOUNTING BRACKET

Fig. A-8 Micropositioner, Mounting Bracket

ADD #26 (3.56 DIA)
2 PLACES AS SHOWN

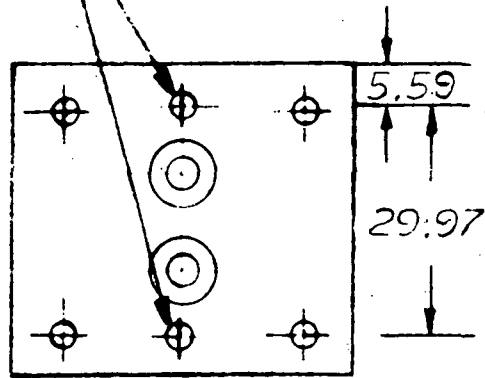
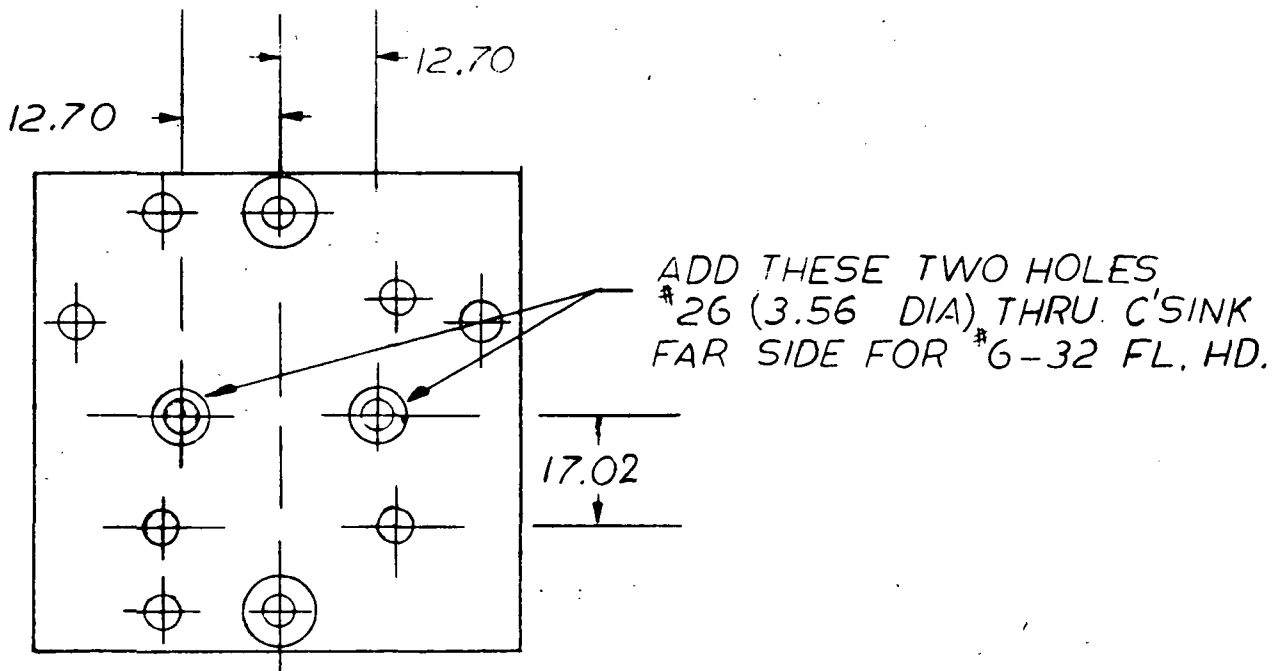

Fig. A-9 Micropositioner, Holder Modification

ALL DIMENSIONS IN MILLIMETERS



ADD THESE TWO HOLES
#26 (3.56 DIA) THRU. C'SINK
FAR SIDE FOR #6-32 FL. HD.

Fig. A-10 Micropositioner, Adapter Modification.

Appendix B

Wiring Diagram for Mechanized Writing Head

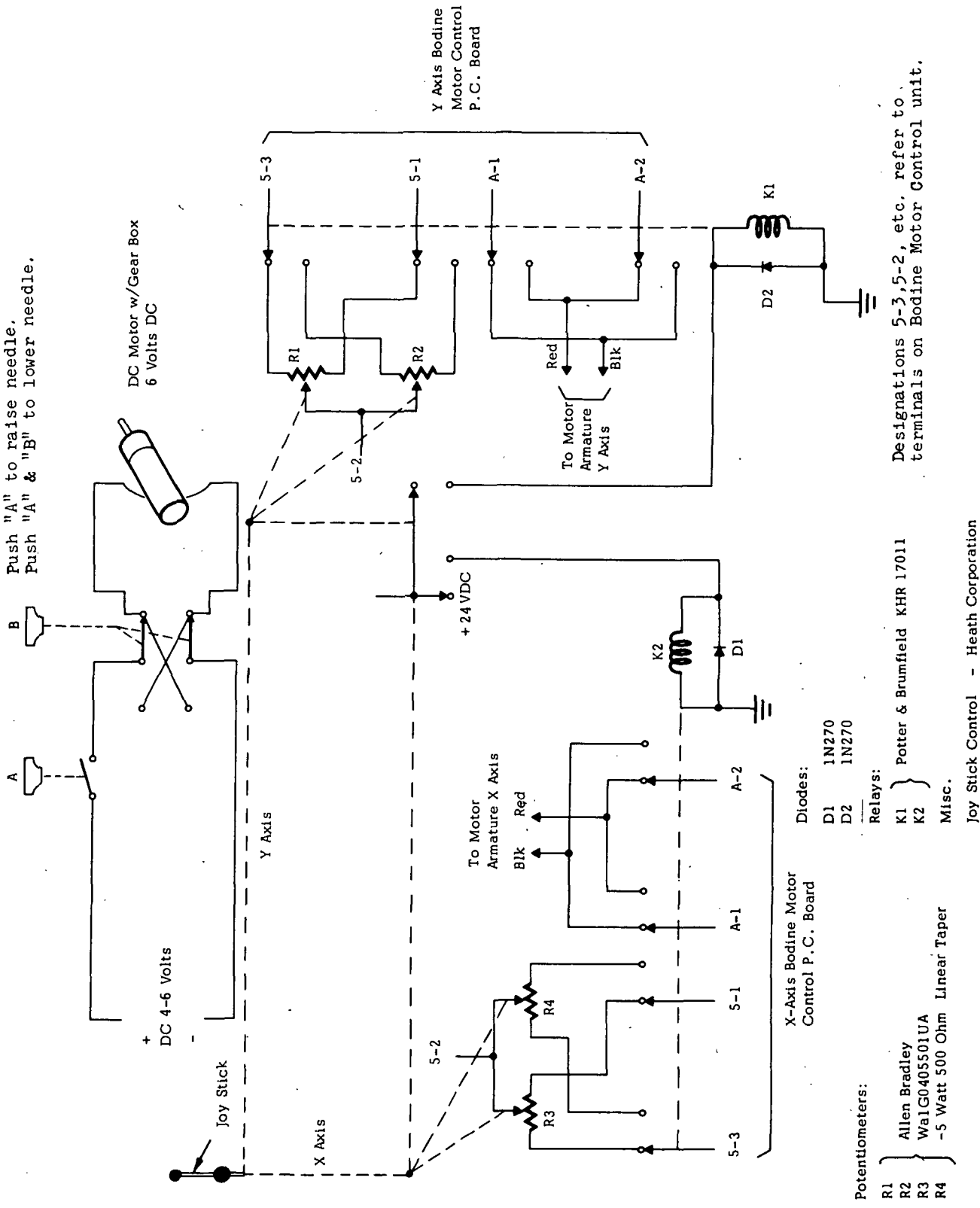

Fig. B-1 Control Circuit for Motorized Writing Head

AMPEX